

FCC and ISED Test Report
Sepura Limited
Tetra Mobile Radio, Model: SCG22

In accordance with FCC 47 CFR Part 15B and ICES-003

Prepared for: Sepura Limited
9000 Cambridge Research Park
Beach Drive
Waterbeach
Cambridge
CB25 9TL
United Kingdom



Add value.
Inspire trust.

FCC ID: XX6SCG2229

IC: 8739A-SCG2229

COMMERCIAL-IN-CONFIDENCE

Document 75948283-01 Issue 01

SIGNATURE			
NAME	JOB TITLE	RESPONSIBLE FOR	ISSUE DATE
Andy Lawson	Senior Engineer	Authorised Signatory	10 July 2029

Signatures in this approval box have checked this document in line with the requirements of TUV SUD document control rules.

ENGINEERING STATEMENT

The measurements shown in this report were made in accordance with the procedures described on test pages. All reported testing was carried out on a sample equipment to demonstrate limited compliance with FCC 47 CFR Part 15B and ICES-003. The sample tested was found to comply with the requirements defined in the applied rules.

RESPONSIBLE FOR	NAME	DATE	SIGNATURE
Testing	Ahmad Javid	10 July 2020	
Testing	Graeme Lawler	10 July 2020	

FCC Accreditation

90987 Octagon House, Fareham Test Laboratory

ISED Accreditation

12669A Octagon House, Fareham Test Laboratory

EXECUTIVE SUMMARY

A sample of this product was tested and found to be compliant with FCC 47 CFR Part 15B: 2019 and ICES-003:2016 for the tests detailed in section 1.3.



DISCLAIMER AND COPYRIGHT

This non-binding report has been prepared by TÜV SÜD with all reasonable skill and care. The document is confidential to the potential Client and TÜV SÜD. No part of this document may be reproduced without the prior written approval of TÜV SÜD. © 2020 TÜV SÜD. This report relates only to the actual item/items tested.

ACCREDITATION

Our UKAS Accreditation does not cover opinions and interpretations and any expressed are outside the scope of our UKAS Accreditation. Results of tests not covered by our UKAS Accreditation Schedule are marked NUA (Not UKAS Accredited).

TÜV SÜD
is a trading name of TÜV SÜD Ltd
Registered in Scotland at East Kilbride,
Glasgow G75 0QF, United Kingdom
Registered number: SC215164

TÜV SÜD Ltd is a
TÜV SÜD Group Company

Phone: +44 (0) 1489 558100
Fax: +44 (0) 1489 558101
www.tuv-sud.co.uk

TÜV SÜD
Octagon House
Concorde Way
Fareham
Hampshire PO15 5RL
United Kingdom



Contents

1	Report Summary	2
1.1	Report Modification Record.....	2
1.2	Introduction.....	2
1.3	Brief Summary of Results	3
1.4	Application Form	4
1.5	Product Information	7
1.6	Deviations from the Standard.....	8
1.7	EUT Modification Record	8
1.8	Test Location	8
2	Test Details	9
2.1	Radiated Disturbance.....	9
3	Incident Reports	28
4	Measurement Uncertainty	29



1 Report Summary

1.1 Report Modification Record

Alterations and additions to this report will be issued to the holders of each copy in the form of a complete document.

Issue	Description of Change	Date of Issue
1	First Issue	10 July 2020

Table 1

1.2 Introduction

Applicant	Sepura Limited
Manufacturer	Sepura Limited
Model Number(s)	SCG22
Serial Number(s)	1PR002007GPH5XV
Hardware Version(s)	Pre-production
Software Version(s)	1785 004 10138
Number of Samples Tested	1
Test Specification/Issue/Date	FCC 47 CFR Part 15B: 2019 ICES-003: 2016
Order Number	PLC-PO015398-1
Date	12-February-2020
Date of Receipt of EUT	10-March-2020
Start of Test	12-May-2020
Finish of Test	13-May-2020
Name of Engineer(s)	Ahmad Javid and Graeme Lawler
Related Document(s)	ANSI C63.4: 2014



1.3 Brief Summary of Results

A brief summary of the tests carried out in accordance with FCC 47 CFR Part 15B and ICES-003 is shown below.

Section	Specification Clause		Test Description	Result	Comments/Base Standard
	Part 15B	ICES-003			
Configuration and Mode: DC Powered, Vehicle RSM - Idle					
2.1	15.109	6.2	Radiated Disturbance	Pass	ANSI C63.4: 2014
Configuration and Mode: DC Powered, Vehicle HBC3 - Idle					
2.1	15.109	6.2	Radiated Disturbance	Pass	ANSI C63.4: 2014

Table 2



1.4 Application Form

Equipment Description

Technical Description: <i>(Please provide a brief description of the intended use of the equipment)</i>	TETRA mobile radio for use within cars, trucks, mobile and fixed control rooms, motorcycles, boats and trains, with Wi-Fi, Bluetooth, GPS and Ethernet functions.
Manufacturer:	Sepura
Model:	SCG22 Series
Part Number:	SCG2229
Hardware Version:	Pre-production
Software Version:	1785 004 10138
FCC ID (if applicable)	XX6SCG2229
IC ID (if applicable)	8739A-SCG2229

Intentional Radiators

Technology	TETRA	Bluetooth LE	Bluetooth Classic / EDR	Wi-Fi 802.11b, g	Wi-Fi 802.11n	Wi-Fi 802.11n
Frequency Band (MHz)	380 - 470 MHz	2402 - 2480 MHz	2402 - 2480 MHz	2412 - 2462 MHz	2412 - 2462 MHz	2422 - 2452 MHz
Conducted Declared Output Power (dBm)	41.5	7.4	7.382	16.5	16.5	16.5
Antenna Gain (dBi)	2	Element 3: 2 dBi	Element 3: 2 dBi	Element 3: 2 dBi	Element 3: 2 dBi	Element 3: 2 dBi
Supported Bandwidth(s) (MHz)	0.025 / 0.02	1	1	20	20	40
Modulation Scheme(s)	$\pi/4$ DQPSK	GFSK	GFSK $\pi/4$ DQPSK 8DPSK	802.11b: CCK, DBPSK, DQPSK 802.11g: BPSK, QPSK, 16QAM, 64QAM	BPSK, QPSK, 16QAM, 64QAM	BPSK, QPSK, 16QAM, 64QAM
ITU Emission Designator	22K0DXW 20K0DXW	1181F1D	1M01F1D 1M01G1D	19M7G1D	19M7D1D	36M8D1D
Bottom Frequency (MHz)	380	2402	2402	2412	2412	2422
Middle Frequency (MHz)	425	2441	2441	2437	2437	2437
Top Frequency (MHz)	470	2480	2480	2462	2462	2452



Un-intentional Radiators

Highest frequency generated or used in the device or on which the device operates or tunes	2480 MHz
Lowest frequency generated or used in the device or on which the device operates or tunes	32.768 kHz
Class A Digital Device (Use in commercial, industrial or business environment) <input checked="" type="checkbox"/>	
Class B Digital Device (Use in residential environment only) <input type="checkbox"/>	

AC Power Source

AC supply frequency:		Hz
Voltage		V
Max current:		A
Single Phase <input type="checkbox"/> Three Phase <input type="checkbox"/>		

DC Power Source

Nominal voltage:	12	V
Extreme upper voltage:	15.6	V
Extreme lower voltage:	10.8	V
Max current:	5	A

Battery Power Source None

Voltage:		V
End-point voltage:		V (Point at which the battery will terminate)
Alkaline <input type="checkbox"/> Leclanche <input type="checkbox"/> Lithium <input type="checkbox"/> Nickel Cadmium <input type="checkbox"/> Lead Acid* <input type="checkbox"/> *(Vehicle regulated)		
Other <input type="checkbox"/>	Please detail:	

Charging

Can the EUT transmit whilst being charged	Yes <input type="checkbox"/> No <input type="checkbox"/>
---	--

Temperature

Minimum temperature:	-20	°C
Maximum temperature:	+60	°C

Antenna Characteristics

Antenna connector <input checked="" type="checkbox"/>	State impedance	50	Ohm
Temporary antenna connector <input type="checkbox"/>	State impedance		Ohm
Integral antenna <input type="checkbox"/>	Type:		Gain
External antenna <input checked="" type="checkbox"/>	Type:		Gain
For external antenna only: Standard Antenna Jack <input checked="" type="checkbox"/> If yes, describe how user is prohibited from changing antenna (if not professional installed): Equipment is only ever professionally installed <input checked="" type="checkbox"/> Non-standard Antenna Jack <input type="checkbox"/>			



Ancillaries (if applicable)

Manufacturer:	Sepura	Part Number:	GPSB4
Model:	GPSB4 Vehicle Roof Antenna	Country of Origin:	Unknown
Manufacturer:	Sepura	Part Number:	AFB-TET
Model:	AFB-VAR 380-430 MHz antenna	Country of Origin:	Unknown
Manufacturer:	Sepura	Part Number:	AFB-UT
Model:	AFB-VAR 406-472 MHz antenna	Country of Origin:	Unknown
Manufacturer:	Sepura	Part Number:	300-02012 rev001
Model:	Extended SCG Loudspeaker / IO USB Host lead	Country of Origin:	Unknown
Manufacturer:	Sepura	Part Number:	300-02014 rev001
Model:	Extended SCG Expansion Board Loudspeaker / 8 GPIO lead	Country of Origin:	Unknown
Manufacturer:	Sepura	Part Number:	Netgear GS105 ProSAFE Gigabit Switch
Model:	Netgear GS105 ProSAFE Gigabit Switch	Country of Origin:	Unknown
Manufacturer:	Sepura	Part Number:	300-02010
Model:	SCG Power/ignition Lead	Country of Origin:	Unknown
Manufacturer:	Sepura	Part Number:	300-00069
Model:	Mobile Remote Cable 5.0M	Country of Origin:	Unknown
Manufacturer:	Sepura	Part Number:	300-00670
Model:	HBC Interface and Hands-free Box	Country of Origin:	Unknown
Manufacturer:	Sepura	Part Number:	300-00079
Model:	Remote Microphone And Switch Set	Country of Origin:	Unknown
Manufacturer:	Sepura	Part Number:	300-00292
Model:	Remote Microphone (Handsfree Kit) 3m	Country of Origin:	Unknown
Manufacturer:	Sepura	Part Number:	300-01801
Model:	Handset Based Console (HBC3)	Country of Origin:	Unknown
Manufacturer:	Sepura	Part Number:	300-00082
Model:	Detachable Loudspeaker extension Cable	Country of Origin:	Unknown
Manufacturer:	Sepura	Part Number:	300-00062
Model:	Fist microphone	Country of Origin:	Unknown
Manufacturer:	Sepura	Part Number:	300-01808
Model:	SCC3 (colour console)	Country of Origin:	Unknown
Manufacturer:	Sepura	Part Number:	300-01961
Model:	CC VAC RSM (Long Cable)	Country of Origin:	Unknown
Manufacturer:	Sepura	Part Number:	300-00719
Model:	Loudspeaker	Country of Origin:	Unknown
Manufacturer:	Sepura	Part Number:	300-01837
Model:	Loudspeaker	Country of Origin:	Unknown

I hereby declare that the information supplied is correct and complete.
 Name: Chris Beecham
 Position held: Conformance Engineer
 Date: 10 March 2020



1.5 Product Information

1.5.1 Technical Description

The Equipment Under Test (EUT) was a TETRA mobile radio for use within cars, trucks, mobile and fixed control rooms, motorcycles, boats and trains, with Wi-Fi, Bluetooth, GPS and Ethernet functions

1.5.2 EUT Port/Cable Identification

Port	Max Cable Length specified	Usage	Type	Screened
Ethernet Port	100 m	Ethernet	Data	FTP
GPS Antenna Port	15 m	Connection to GPS Antenna	Data	Coax
Tetra Antenna Port	15 m	Connection to Tetra Antenna	Data	Coax
WLAN & Bluetooth Port	8 m	Connection to WLAN Antenna	Data	Coax
DC Positive Permanent	5 m	DC Power to EUT	Positive	No
DC Positive Switched	5 m	DC Power to EUT	Positive	No
DC Negative	5 m	DC Power to EUT	Negative	Yes
USB Port	30 m	Connection to USB	Data	No
SCC3 / HBC3 Port	0.5 m	Connection to SCC3 / HBC3 Port	Data	No
IO Cable	6 m	Data	Data	No

Table 3

Client to confirm maximum specified length of each cable, and whether screened or not

1.5.3 Test Configuration

Configuration	Description
DC Powered, Vehicle RSM	The EUT was powered by 12 V DC. The EUT was populated with two SCC3 units each with a Vehicle RSM connected. Also, a Hands-Free Kit was connected to each of the SCC3 units. Two loudspeakers of type 300-00719 were connected.
DC Powered, Vehicle HBC3	The EUT was powered by 12 V DC. The EUT was populated with two HBC3 units each with a Hands-Free Kit connected. Two Heavy Duty Loudspeakers of type 300-01837 were connected.

Table 4

1.5.4 Modes of Operation

Mode	Description
Idle	All transmitters were configured to idle. GPS was set to receive. Bi-directional traffic was established over the ethernet port.

Table 5



1.6 Deviations from the Standard

No deviations from the applicable test standard were made during testing.

1.7 EUT Modification Record

The table below details modifications made to the EUT during the test programme.

The modifications incorporated during each test are recorded on the appropriate test pages.

Modification State	Description of Modification still fitted to EUT	Modification Fitted By	Date Modification Fitted
Model: SCG22, Serial Number: 1PR002007GPH5XV			
0	As supplied by the customer	Not Applicable	Not Applicable

Table 6

1.8 Test Location

TÜV SÜD conducted the following tests at our Fareham Test Laboratory.

Test Name	Name of Engineer(s)	Accreditation
Configuration and Mode: DC Powered, Vehicle RSM - Idle		
Radiated Disturbance	Ahmad Javid and Graeme Lawler	UKAS
Configuration and Mode: DC Powered, Vehicle HBC3 - Idle		
Radiated Disturbance	Ahmad Javid	UKAS

Table 7

Office Address:

Octagon House
Concorde Way
Segensworth North
Fareham
Hampshire
PO15 5RL
United Kingdom



2 Test Details

2.1 Radiated Disturbance

2.1.1 Specification Reference

FCC 47 CFR Part 15B, Clause 15.109
ICES-003, Clause 6.2

2.1.2 Equipment Under Test and Modification State

SCG22, S/N: 1PR002007GPH5XV - Modification State 0

2.1.3 Date of Test

12-May-2020 to 13-May-2020

2.1.4 Test Method

The EUT was set up on a non-conductive table 0.8 m above a reference ground plane within a semi-anechoic chamber on a remotely controlled turntable.

A pre-scan of the EUT emissions profile using a peak detector was made at a 3 m antenna distance whilst varying the antenna-to-EUT azimuth and polarisation.

For an EUT which could reasonable be used in multiple planes, pre-scans were performed with the EUT orientated in X, Y and Z planes with reference to the ground plane.

Using a list of the highest emissions detected during the pre-scan along with their bearing and associated antenna polarisation, the EUT was then formally measured using a Quasi-Peak, Peak or CISPR Average detector as appropriate.

The readings were maximised by adjusting the antenna height, polarisation and turntable azimuth, in accordance with the specification.

2.1.5 Example Calculation

Below 1 GHz:

$$\begin{aligned}\text{Quasi-Peak level (dB}\mu\text{V/m)} &= \text{Receiver level (dB}\mu\text{V)} + \text{Correction Factor (dB/m)} \\ \text{Margin (dB)} &= \text{Quasi-Peak level (dB}\mu\text{V/m)} - \text{Limit (dB}\mu\text{V/m)}\end{aligned}$$

Above 1 GHz:

$$\begin{aligned}\text{CISPR Average level (dB}\mu\text{V/m)} &= \text{Receiver level (dB}\mu\text{V)} + \text{Correction Factor (dB/m)} \\ \text{Margin (dB)} &= \text{CISPR Average level (dB}\mu\text{V/m)} - \text{Limit (dB}\mu\text{V/m)}\end{aligned}$$

$$\begin{aligned}\text{Peak level (dB}\mu\text{V/m)} &= \text{Receiver level (dB}\mu\text{V)} + \text{Correction Factor (dB/m)} \\ \text{Margin (dB)} &= \text{Peak level (dB}\mu\text{V/m)} - \text{Limit (dB}\mu\text{V/m)}\end{aligned}$$

2.1.6 Example Test Setup Diagram

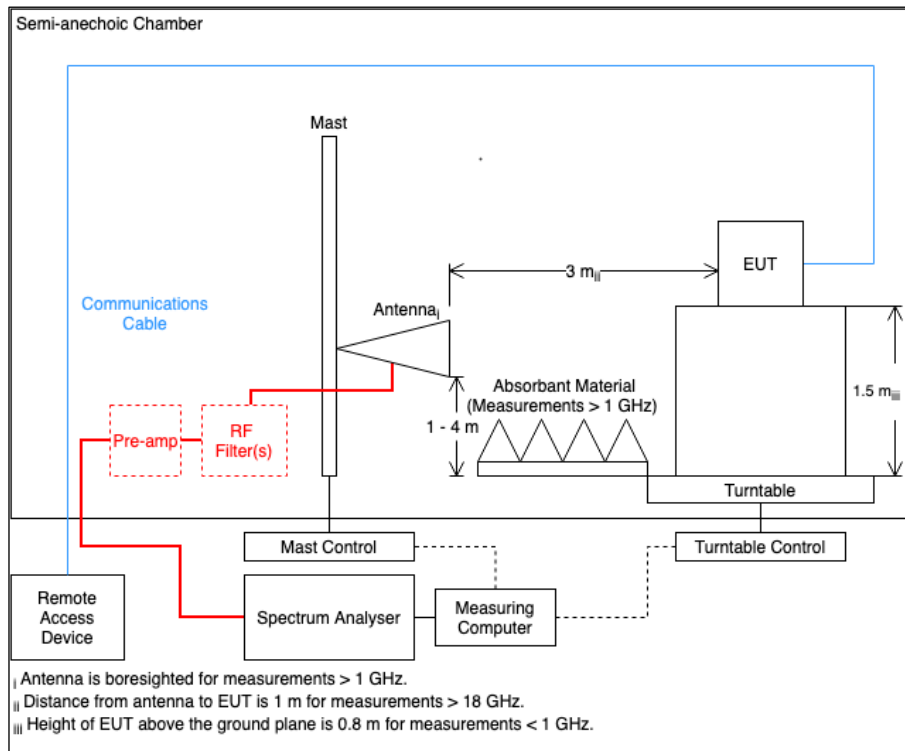

Figure 1

2.1.7 Environmental Conditions

Ambient Temperature 21.4 - 21.5 °C
 Relative Humidity 26.6 - 33.0 %

2.1.8 Specification Limits

Required Specification Limits, Field Strength (Class A @ 10 m)		
Frequency Range (MHz)	Test Limit (µV/m)	Test Limit (dBµV/m)
30 to 88	90	39.1
88 to 216	150	43.5
216 to 960	210	46.4
Above 960	300	49.5

Supplementary information:
 Note 1. Quasi-Peak detector to be used for measurements below 1 GHz.
 Note 2. CISPR Average detector to be used for measurements above 1 GHz.
 Note 3. Peak test limit above 1 GHz is 20 dB higher than the CISPR Average test limit.

Table 8



2.1.9 Test Results

Results for Configuration and Mode: DC Powered and Vehicle RSM - Idle.

The test was performed in accordance with the Class A limits.

Performance assessment of the EUT made during this test: Pass.

Detailed results are shown below.

Highest frequency generated or used within the EUT: 2.48 GHz
 Which necessitates an upper frequency test limit of: 13.00 GHz

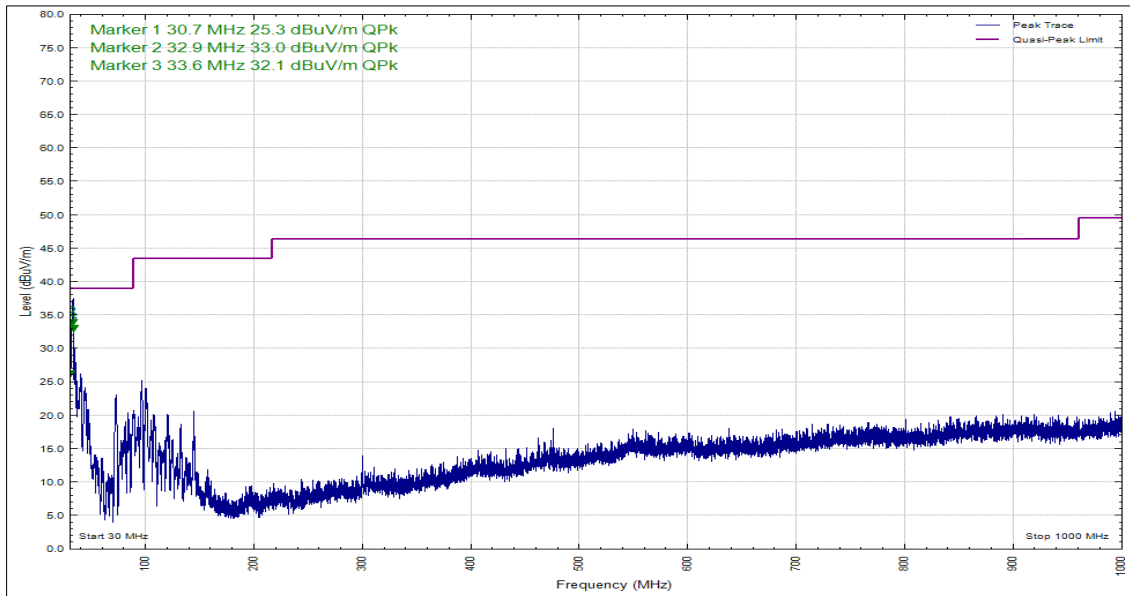

Figure 2 - 30 MHz to 1 GHz, Quasi-Peak, Vertical

Frequency (MHz)	Level (dBuV/m)	Limit (dBuV/m)	Margin (dB)	Detector	Angle (°)	Height (cm)	Polarisation
32.907	33.0	39.1	-6.1	Q-Peak	204	107	Vertical
33.552	32.1	39.1	-7.0	Q-Peak	358	104	Vertical

Table 9

No other final measurements were made as all other peak emissions seen above the measurement system noise floor during the pre-scan were greater than 10 dB below the test limit.

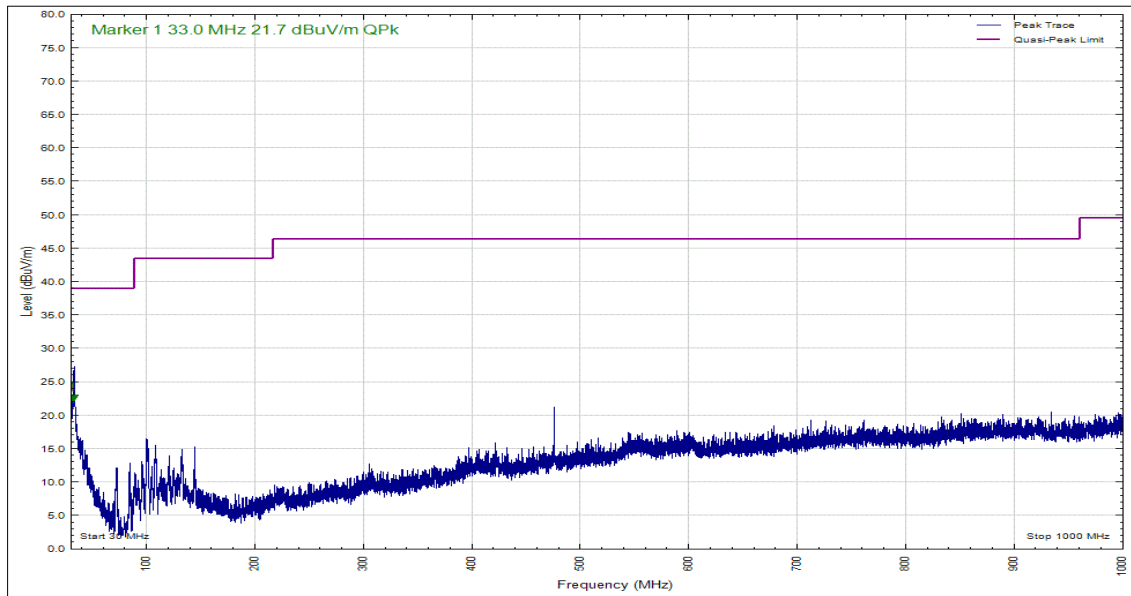

Figure 3 - 30 MHz to 1 GHz, Quasi-Peak, Horizontal

Frequency (MHz)	Level (dBuV/m)	Limit (dBuV/m)	Margin (dB)	Detector	Angle (°)	Height (cm)	Polarisation
*							

Table 10

*No final measurements were made as all peak emissions seen above the measurement system noise floor during the pre-scan were greater than 10 dB below the test limit.

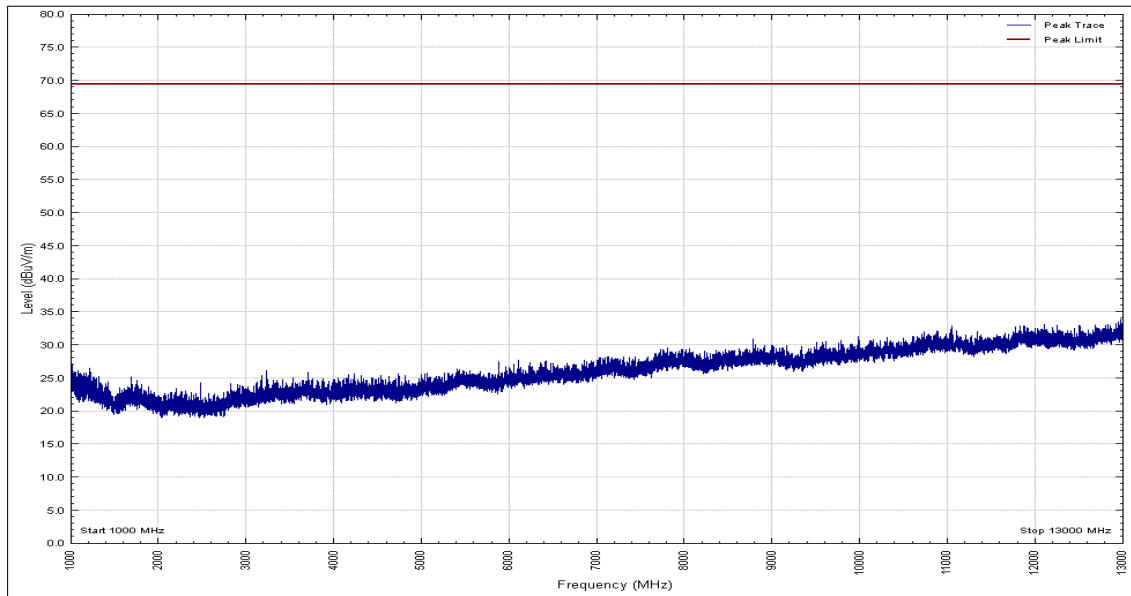

Figure 4 - 1 GHz to 13 GHz, Peak, Vertical

Frequency (MHz)	Level (dBuV/m)	Limit (dBuV/m)	Margin (dB)	Detector	Angle (°)	Height (cm)	Polarisation
*							

Table 11

*No final measurements were made as all peak emissions seen above the measurement system noise floor during the pre-scan were greater than 10 dB below the test limit.

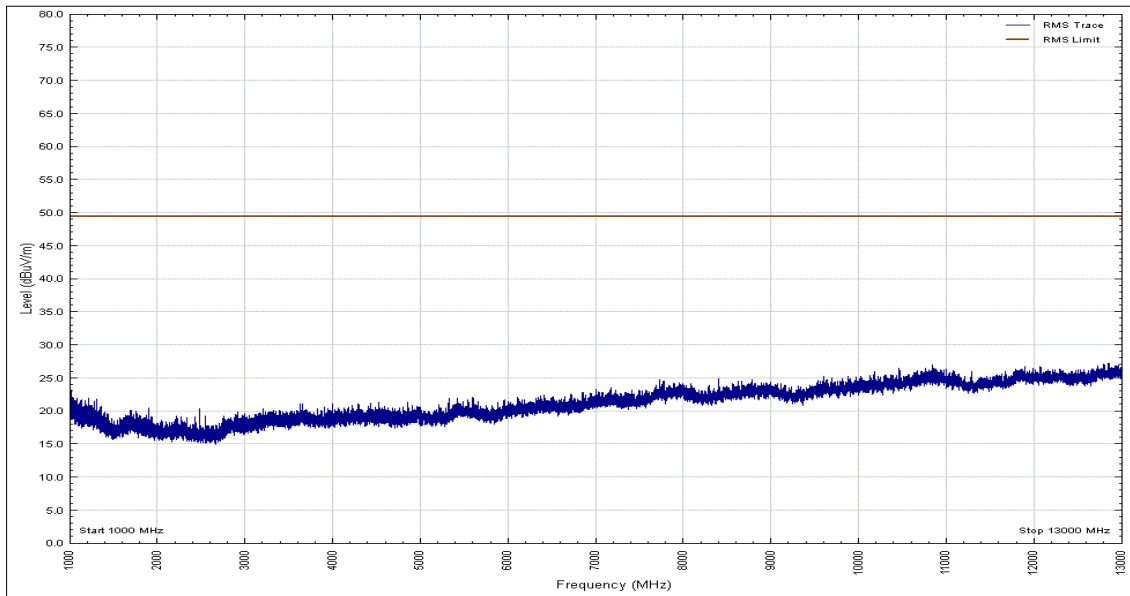

Figure 5 - 1 GHz to 13 GHz, Average, Vertical

Frequency (MHz)	Level (dBuV/m)	Limit (dBuV/m)	Margin (dB)	Detector	Angle (°)	Height (cm)	Polarisation
*							

Table 12

*No final measurements were made as all peak emissions seen above the measurement system noise floor during the pre-scan were greater than 10 dB below the test limit.

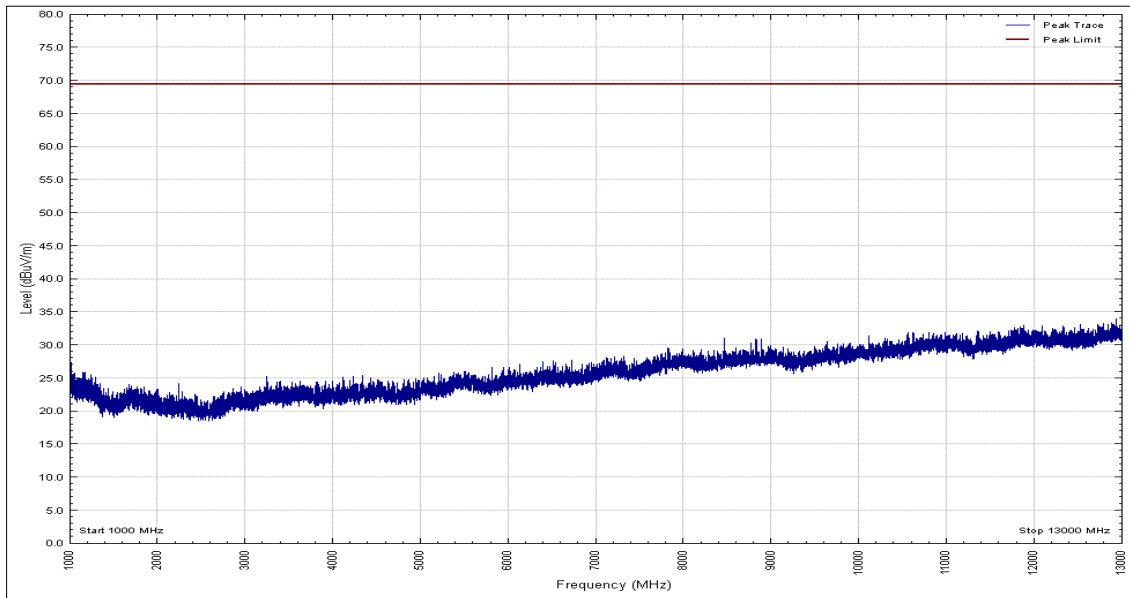

Figure 6 - 1 GHz to 13 GHz, Peak, Horizontal

Frequency (MHz)	Level (dBuV/m)	Limit (dBuV/m)	Margin (dB)	Detector	Angle (°)	Height (cm)	Polarisation
*							

Table 13

*No final measurements were made as all peak emissions seen above the measurement system noise floor during the pre-scan were greater than 10 dB below the test limit.

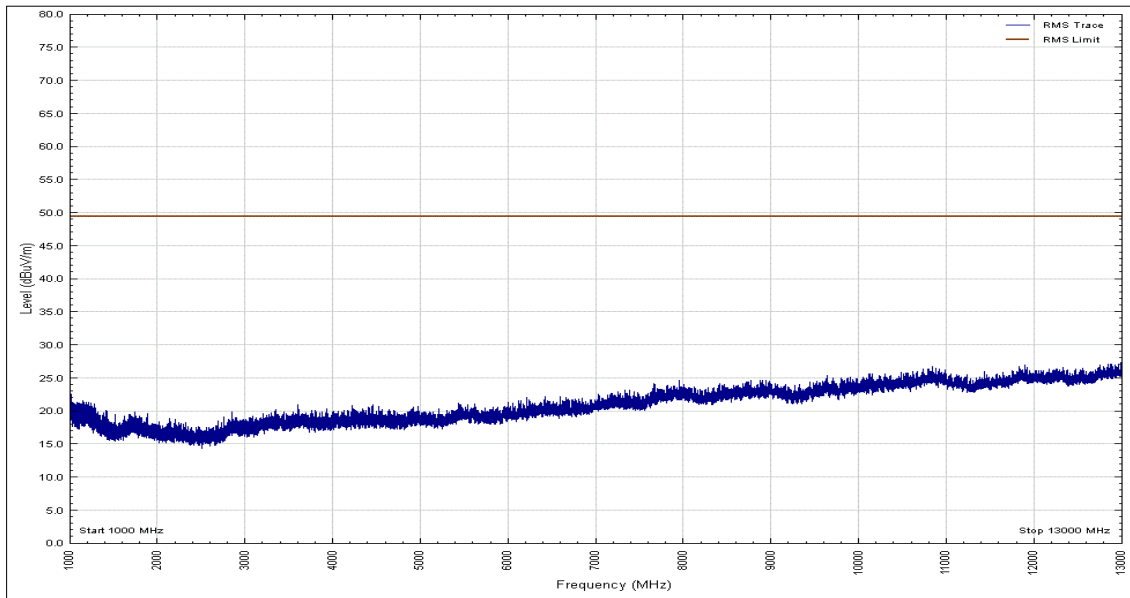

Figure 7 - 1 GHz to 13 GHz, Average, Horizontal

Frequency (MHz)	Level (dBuV/m)	Limit (dBuV/m)	Margin (dB)	Detector	Angle (°)	Height (cm)	Polarisation
*							

Table 14

*No final measurements were made as all peak emissions seen above the measurement system noise floor during the pre-scan were greater than 10 dB below the test limit.

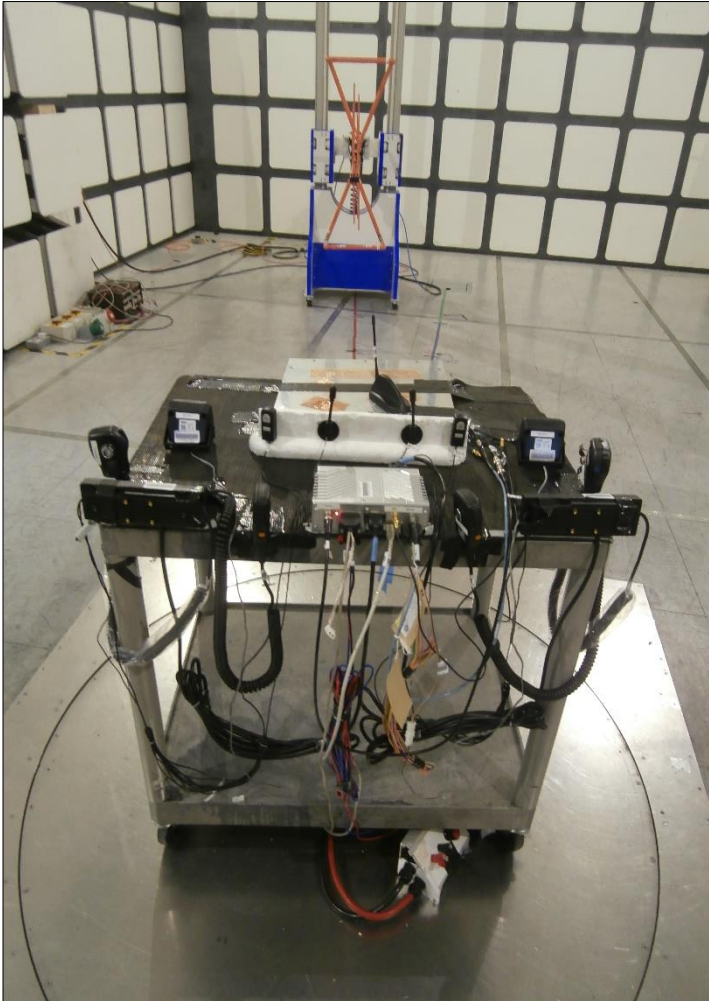

Figure 8 - Test Setup - 30 MHz to 1 GHz

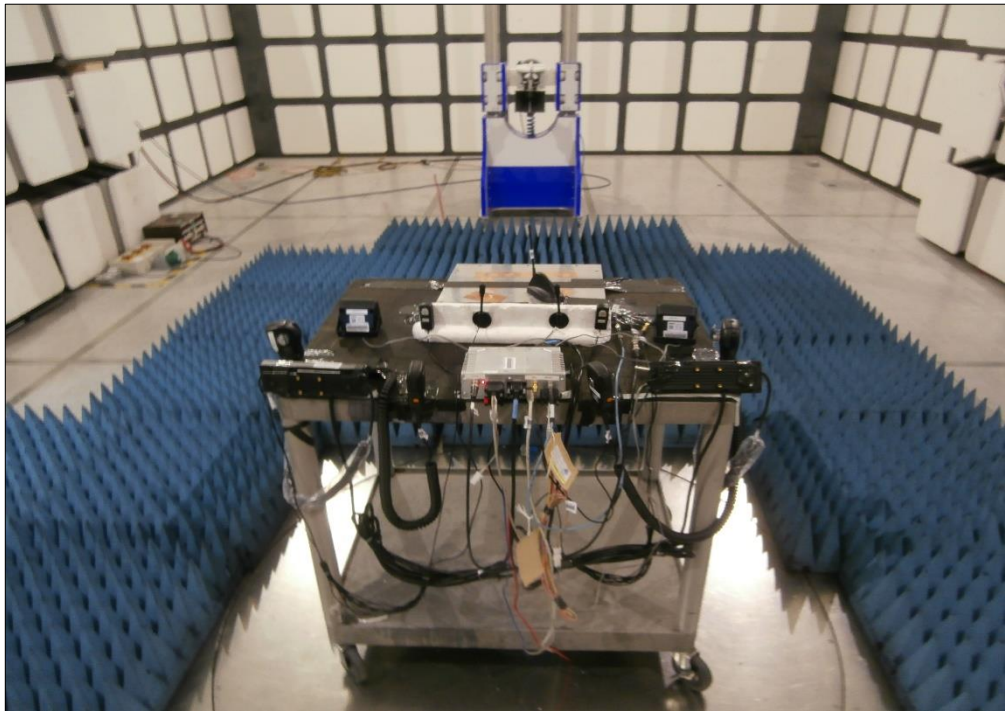

Figure 9 - Test Setup - 1 GHz to 8 GHz

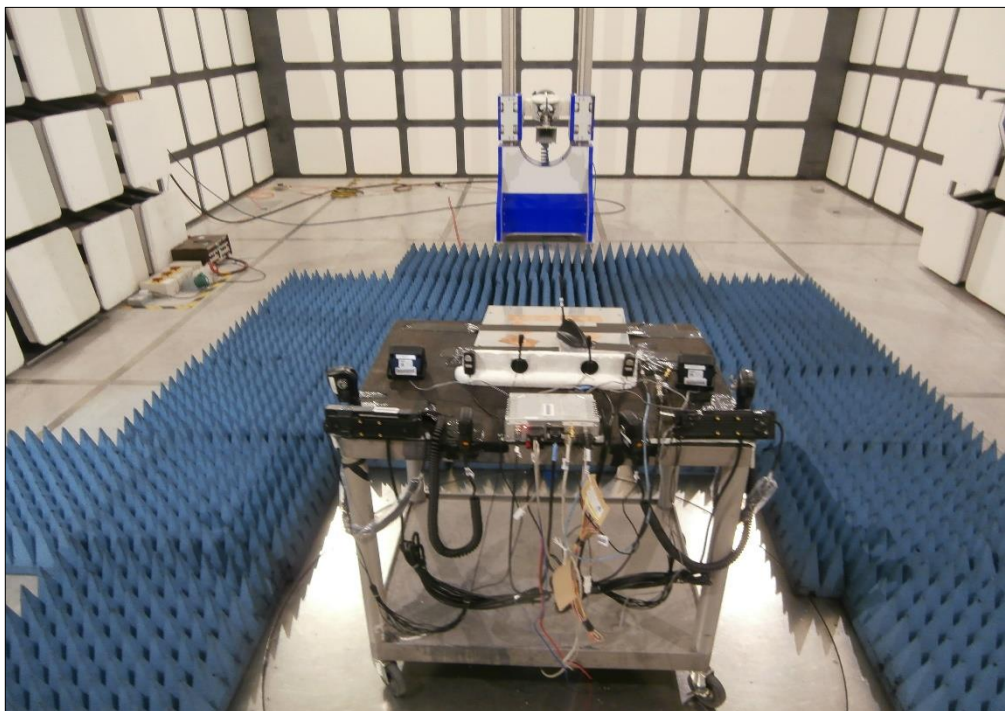

Figure 10 - Test Setup - 8 GHz to 13 GHz



Results for Configuration and Mode: DC Powered and Vehicle HBC3 - Idle.

The test was performed in accordance with the Class A limits.

Performance assessment of the EUT made during this test: Pass.

Detailed results are shown below.

Highest frequency generated or used within the EUT: 2.48 GHz
 Which necessitates an upper frequency test limit of: 13.00 GHz

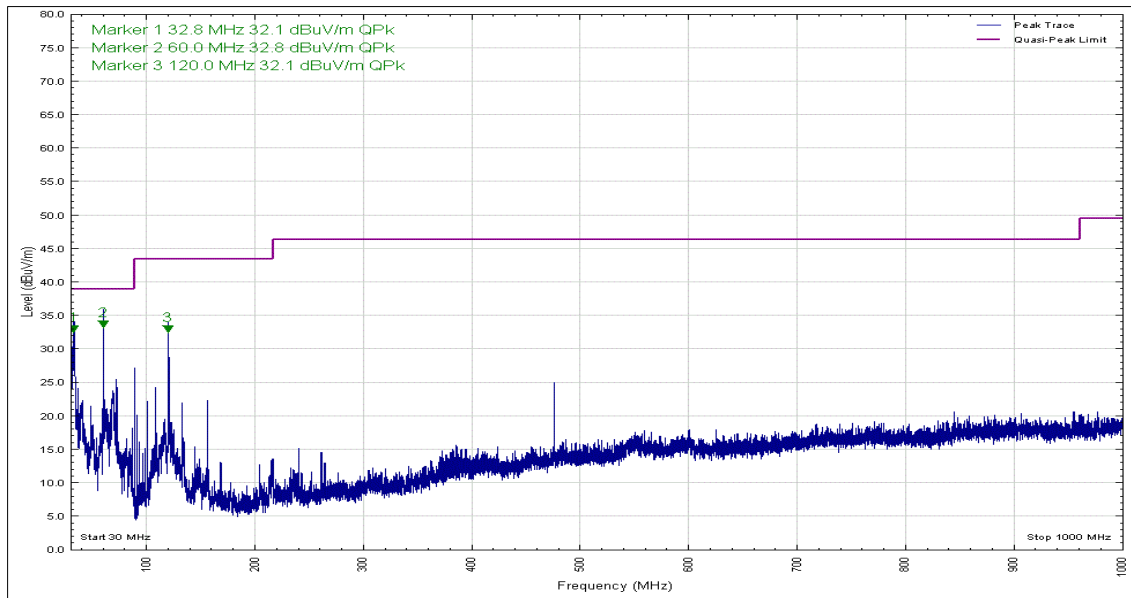

Figure 11 - 30 MHz to 1 GHz, Quasi-Peak, Vertical

Frequency (MHz)	Level (dBuV/m)	Limit (dBuV/m)	Margin (dB)	Detector	Angle (°)	Height (cm)	Polarisation
32.832	32.1	39.1	-7.0	Q-Peak	0	100	Vertical
60.000	32.8	39.1	-6.3	Q-Peak	9	100	Vertical
119.999	32.1	43.5	-11.4	Q-Peak	131	108	Vertical

Table 15

No other final measurements were made as all other peak emissions seen above the measurement system noise floor during the pre-scan were greater than 10 dB below the test limit.

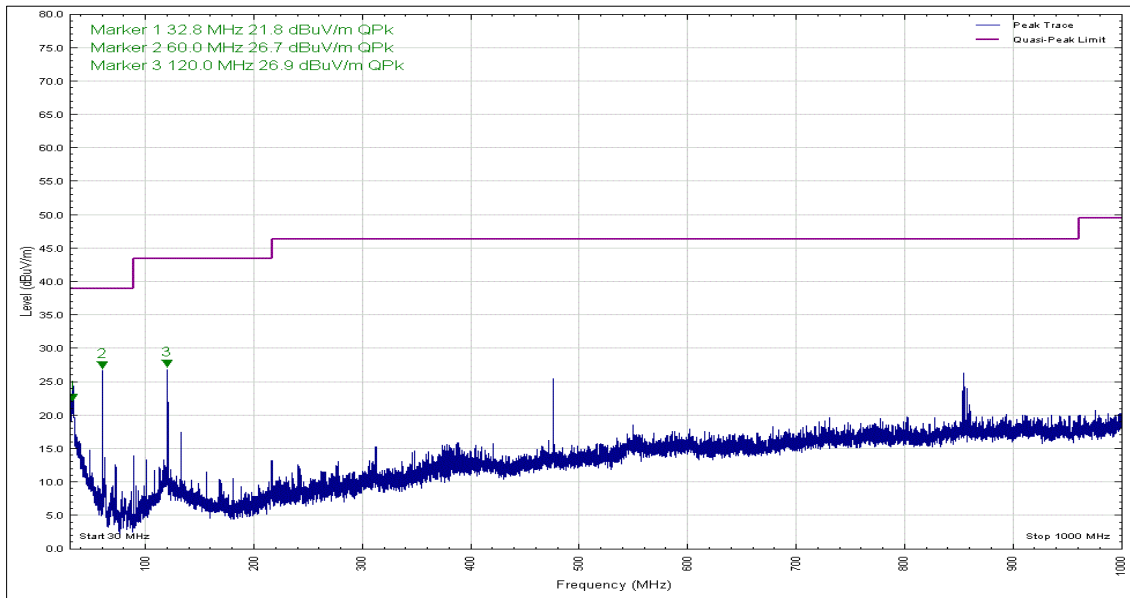

Figure 12 - 30 MHz to 1 GHz, Quasi-Peak, Horizontal

Frequency (MHz)	Level (dBuV/m)	Limit (dBuV/m)	Margin (dB)	Detector	Angle (°)	Height (cm)	Polarisation
32.838	21.8	39.1	-17.3	Q-Peak	283	107	Horizontal
60.004	26.7	39.1	-12.4	Q-Peak	262	359	Horizontal
119.999	26.9	43.5	-16.7	Q-Peak	90	249	Horizontal

Table 16

No other final measurements were made as all other peak emissions seen above the measurement system noise floor during the pre-scan were greater than 10 dB below the test limit.

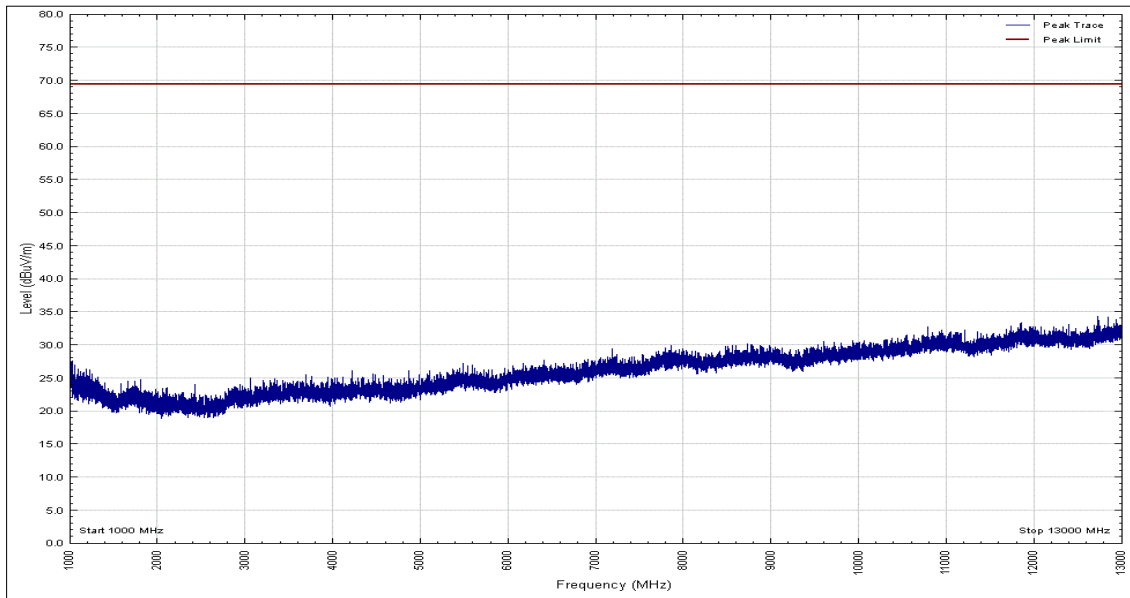

Figure 13 - 1 GHz to 13 GHz, Peak, Vertical

Frequency (MHz)	Level (dBuV/m)	Limit (dBuV/m)	Margin (dB)	Detector	Angle (°)	Height (cm)	Polarisation
*							

Table 17

*No final measurements were made as all peak emissions seen above the measurement system noise floor during the pre-scan were greater than 10 dB below the test limit.

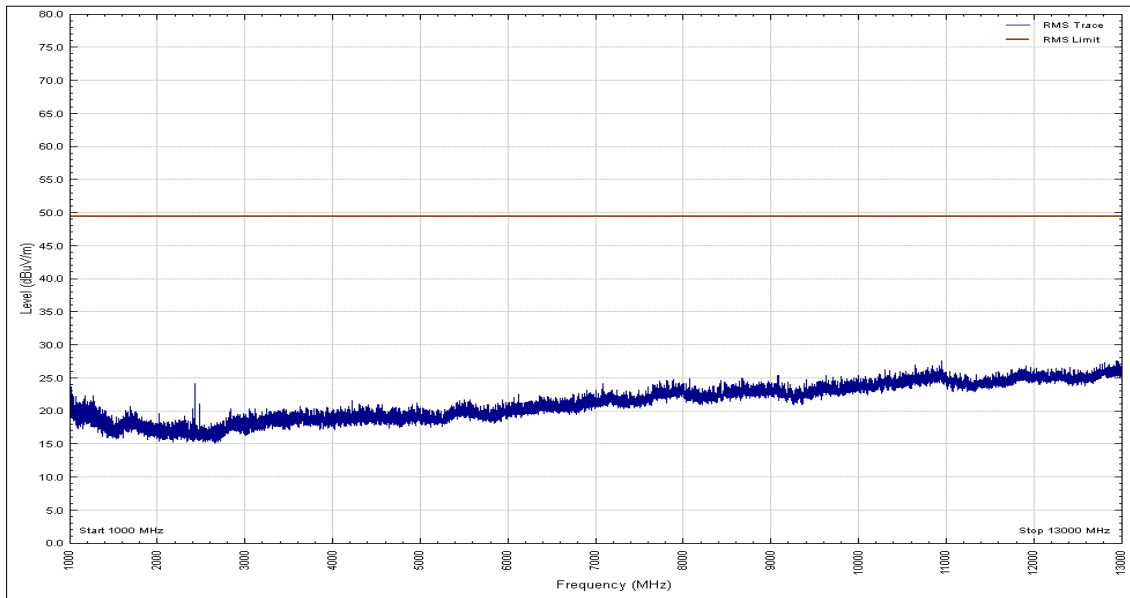

Figure 14 - 1 GHz to 13 GHz, Average, Vertical

Frequency (MHz)	Level (dBuV/m)	Limit (dBuV/m)	Margin (dB)	Detector	Angle (°)	Height (cm)	Polarisation
*							

Table 18

*No final measurements were made as all peak emissions seen above the measurement system noise floor during the pre-scan were greater than 10 dB below the test limit.

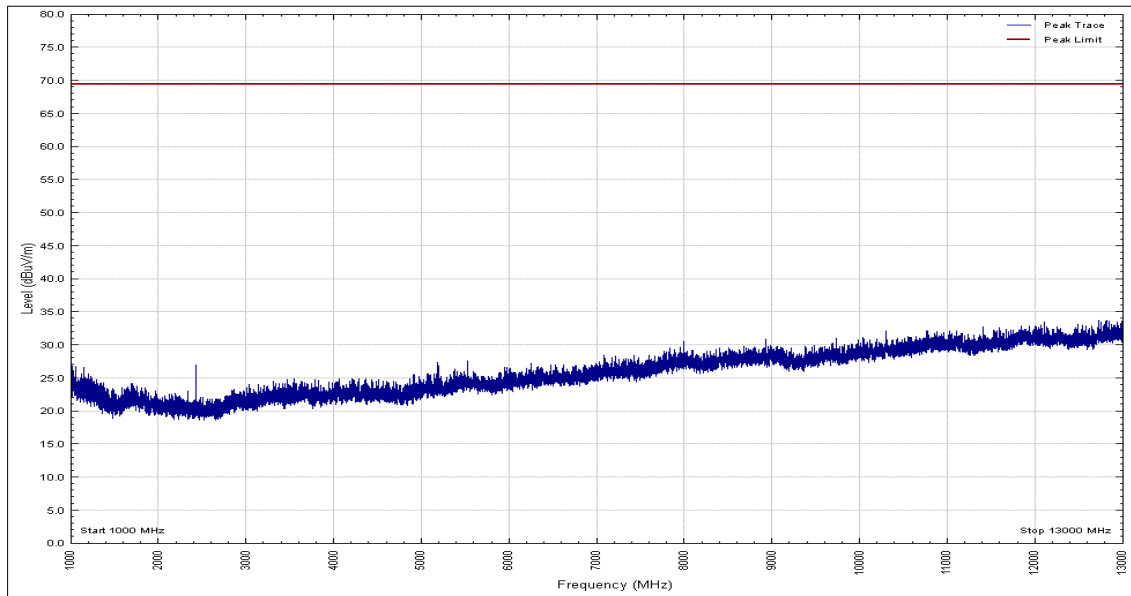

Figure 15 - 1 GHz to 13 GHz, Peak, Horizontal

Frequency (MHz)	Level (dBuV/m)	Limit (dBuV/m)	Margin (dB)	Detector	Angle (°)	Height (cm)	Polarisation
*							

Table 19

*No final measurements were made as all peak emissions seen above the measurement system noise floor during the pre-scan were greater than 10 dB below the test limit.

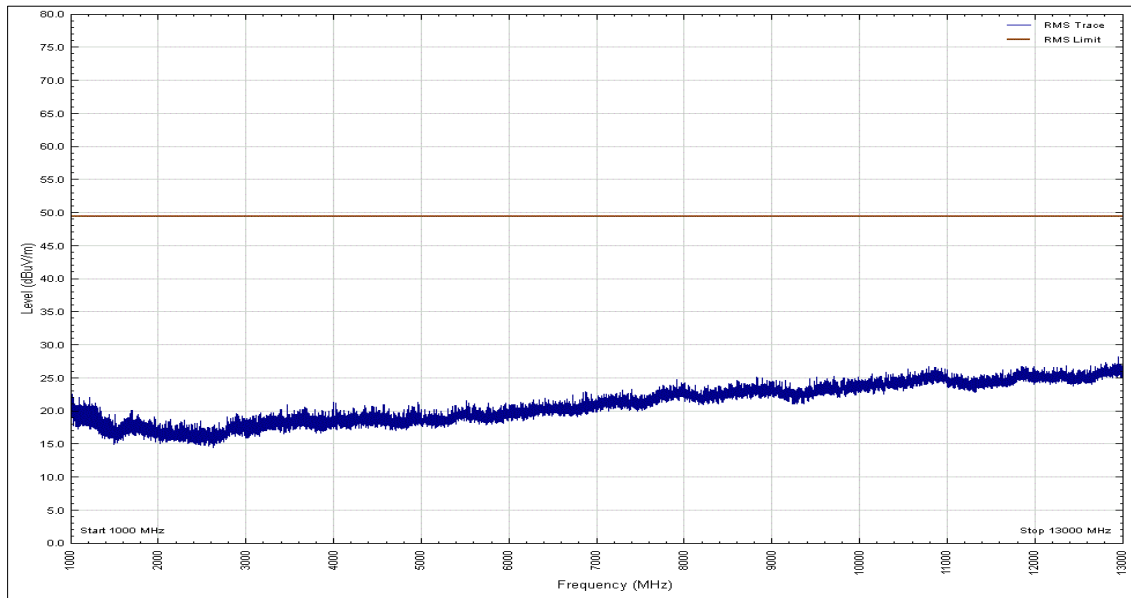

Figure 16 - 1 GHz to 13 GHz, Average, Horizontal

Frequency (MHz)	Level (dBuV/m)	Limit (dBuV/m)	Margin (dB)	Detector	Angle (°)	Height (cm)	Polarisation
*							

Table 20

*No final measurements were made as all peak emissions seen above the measurement system noise floor during the pre-scan were greater than 10 dB below the test limit.

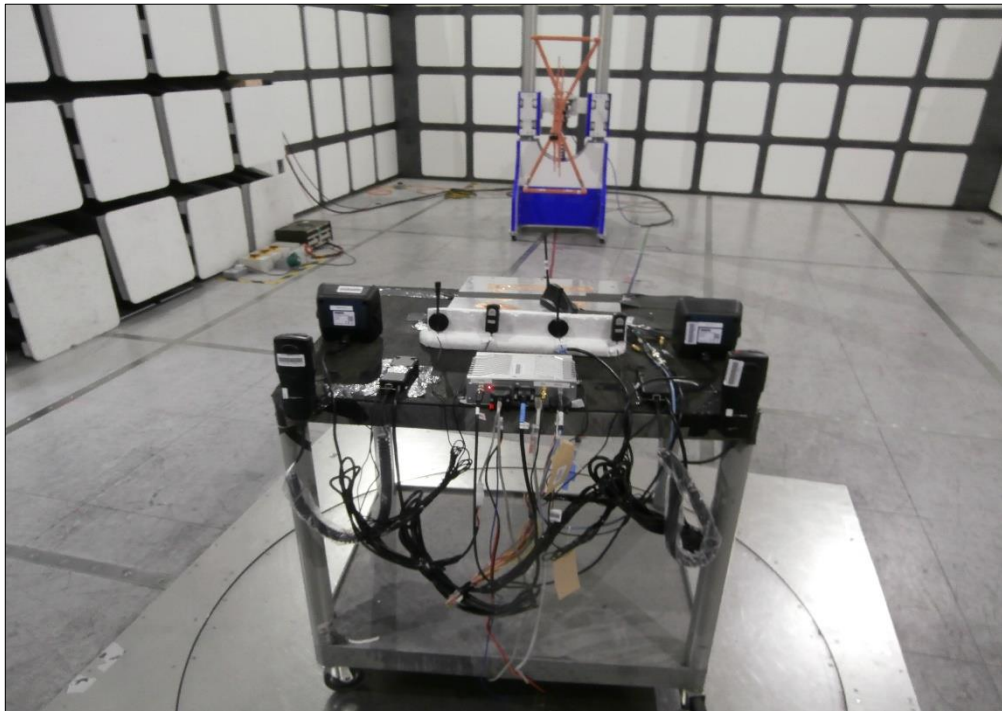

Figure 17 - Test Setup - 30 MHz to 1 GHz

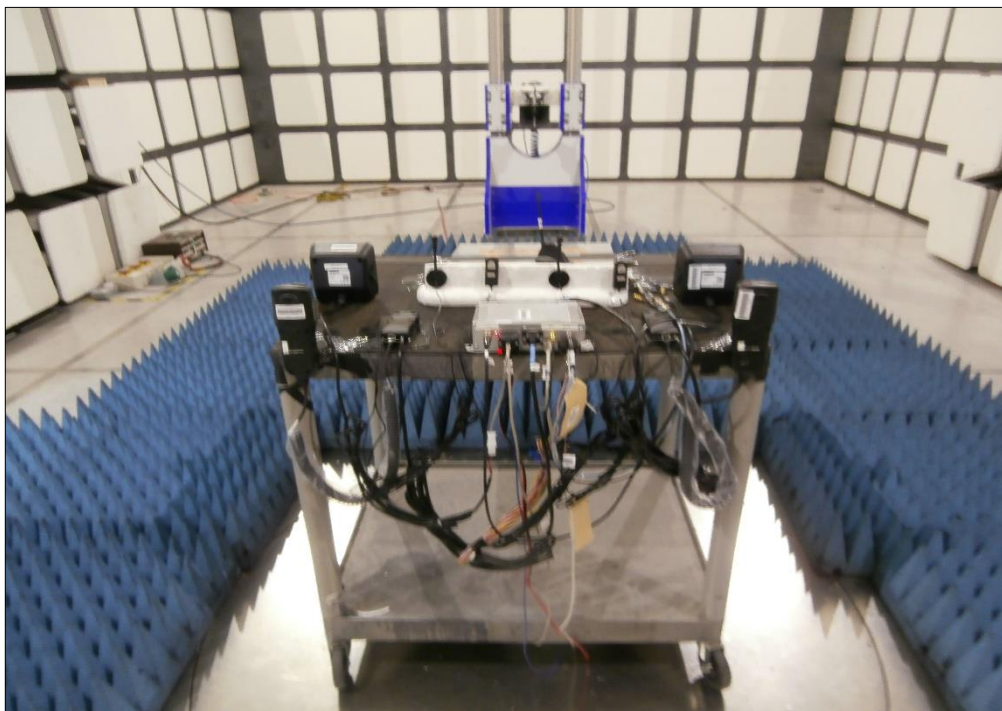

Figure 18 - Test Setup - 1 GHz to 8 GHz

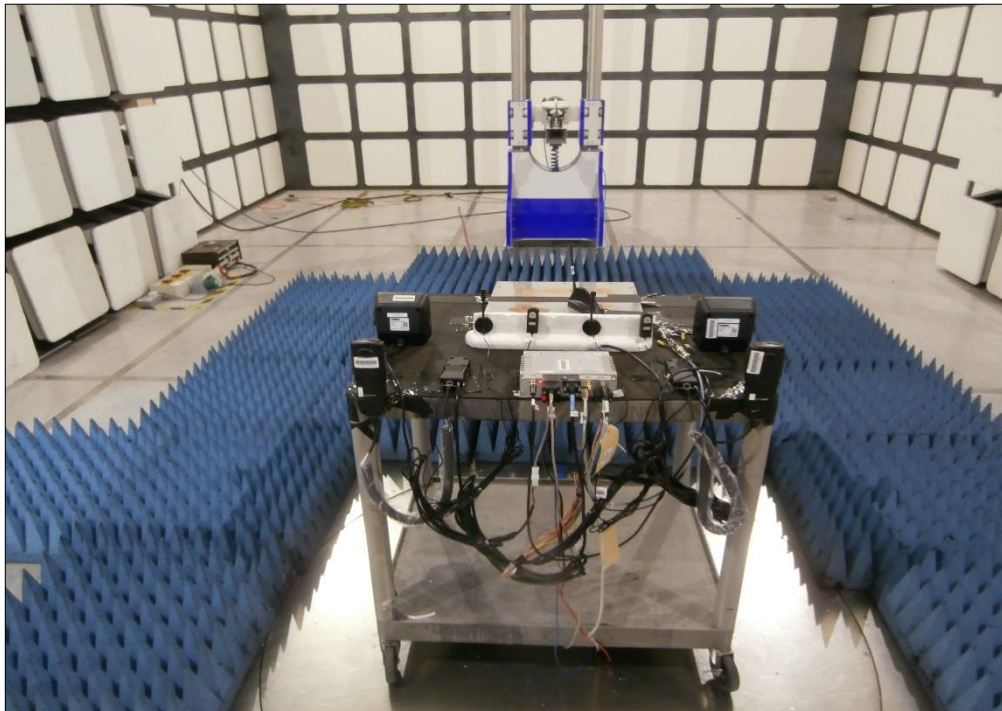

Figure 19 - Test Setup - 8 GHz to 13 GHz



2.1.10 Test Location and Test Equipment Used

This test was carried out in EMC Chamber 5.

Instrument	Manufacturer	Type No	TE No	Calibration Period (months)	Calibration Due
Screened Room (5)	Rainford	Rainford	1545	36	23-Jan-2021
EmX Emissions Software	TUV SUD	EmX V.V1.5.10	5125	-	Software
EMI Test Receiver	Rohde & Schwarz	ESW44	5527	12	06-Feb-2021
Turntable Controller	Inn-Co GmbH	CO 1000	1606	-	TU
Mast Controller	Maturo GmbH	NCD	4810	-	TU
Tilt Antenna Mast	Maturo GmbH	TAM 4.0-P	4811	-	TU
Preamplifier (30dB 1GHz to 18GHz)	Schwarzbeck	BBV 9718 C	5261	12	07-Apr-2021
4dB Attenuator	Pasternack	PE7047-4	4935	24	30-Sep-2021
Antenna with permanent attenuator (Bilog)	Chase	CBL6143	2904	24	30-Sep-2021
Double Ridge Broadband Horn Antenna	Schwarzbeck	BBHA 9120 B	4848	12	10-Mar-2021
Antenna (DRG Horn 7.5-18GHz)	Schwarzbeck	HWRD750	5348	12	04-Sep-2020
Cable (Yellow, Rx, Km-Km 2m)	Scott Cables	KPS-1501-2000-KPS	4527	6	09-Jun-2020
Cable (18 GHz)	Rosenberger	LU7-071-1000	5103	12	06-Oct-2020
8 Meter Cable	Teledyne	PR90-088-8MTR	5212	12	30-Aug-2020
Multimeter	Iso-tech	IDM 101	2118	12	07-Feb-2021
Programmable Power Supply	Iso-tech	IPS 2010	2437	-	O/P Mon
Comb Generator	Schaffner	RSG1000	3034	-	TU
Thermo-Hygro-Barometer	PCE Instruments	OCE-THB-40	5470	12	16-Mar-2021

Table 21

TU – Traceability Unscheduled
 O/P Mon – Output Monitored Using Calibrated Test Equipment



3 Incident Reports

No incidents reports were raised.



4 Measurement Uncertainty

For a 95% confidence level, the measurement uncertainties for defined systems are:

Test Name	Measurement Uncertainty
Radiated Disturbance	30 MHz to 1 GHz, Bilog Antenna, ± 5.2 dB 1 GHz to 40 GHz, Horn Antenna, ± 6.3 dB

Table 22

Worst case error for both Time and Frequency measurement 12 parts in 10^6 .

Measurement Uncertainty Decision Rule

Determination of conformity with the specification limits is based on the decision rule according to IEC Guide 115: 2007, clause 4.4.3 and 4.5.1.