

**ELECTROMAGNETIC EMISSIONS COMPLIANCE REPORT  
INTENTIONAL RADIATOR CERTIFICATION TO  
FCC PART 15 SUBPART C REQUIREMENT**

*OF*

**Fingerprint Access Controller**

**Model No.: eNBioAccess-T9**

**FCC ID: XX2-T9**

**Trademark: NITGEN**

**Report No.: ES181203025E2**

**Issue Date: December 28, 2018**

*Prepared for*

**UNION COMMUNITY CO.,LTD.  
Hyundai Topics Bldg. Bangi 2-dong, Songpa-gu, Seoul, Korea**

*Prepared by*

**EMTEK(SHENZHEN) CO., LTD.**

**Bldg 69, Majialong Industry Zone, Nanshan District, Shenzhen,  
Guangdong, China**

**Tel: +86-769-22807078**

**Fax: +86-769-22807079**

**This report shall not be reproduced, except in full, without the written approval of  
EMTEK(SHENZHEN) CO., LTD.**

**VERIFICATION OF COMPLIANCE**

Applicant:	UNION COMMUNITY CO.,LTD. Hyundai Topics Bldg. Bangi 2-dong, Songpa-gu, Seoul, Korea
Manufacturer:	Union Community Co.,Ltd. Hyundai Topics Bldg. Bangi 2-dong, Songpa-gu, Seoul, Korea
Product Description:	Fingerprint Access Controller
Model Number:	eNBioAccess-T9
Trademark:	NITGEN

**We hereby certify that:**

The above equipment was tested by EMTEK(SHENZHEN) CO., LTD. The test data, data evaluation, test procedures, and equipment configurations shown in this report were made in accordance with the procedures given in ANSI C63.10-2013 and the energy emitted by the sample EUT tested as described in this report is in compliance with conducted and radiated emission limits of FCC Rules Part 15.225(2018).

Date of Test : December 03, 2018 to December 26, 2018

*Yaping Shen*

Prepared/Tested by :

Yaping Shen/Editor

*Joe Xia*

Reviewer :

Joe Xia/Supervisor

Approved & Authorized Signer :

*Lisa Wang*

Lisa Wang/Manager

**Modified Information**

Version	Summary	Revision Date	Report No.
Ver.1.0	Original Report	/	ES181203025E2

## Table of Contents

<b>1</b>	<b>GENERAL INFORMATION .....</b>	<b>5</b>
1.1	PRODUCT DESCRIPTION .....	5
1.2	RELATED SUBMITTAL(S) / GRANT(S).....	5
1.3	TEST METHODOLOGY .....	6
1.4	SPECIAL ACCESSORIES .....	6
1.5	EQUIPMENT MODIFICATIONS .....	6
1.6	TEST FACILITY.....	6
<b>2</b>	<b>SYSTEM TEST CONFIGURATION.....</b>	<b>7</b>
2.1	EUT CONFIGURATION .....	7
2.2	EUT EXERCISE .....	7
2.3	TEST PROCEDURE.....	7
2.4	CONFIGURATION OF TESTED SYSTEM .....	8
<b>3</b>	<b>SUMMARY OF TEST RESULTS.....</b>	<b>9</b>
<b>4</b>	<b>TEST SYSTEM UNCERTAINTY.....</b>	<b>10</b>
<b>5</b>	<b>CONDUCTED EMISSIONS TEST .....</b>	<b>11</b>
5.1	MEASUREMENT PROCEDURE.....	11
5.2	TEST SET-UP (BLOCK DIAGRAM OF CONFIGURATION) .....	11
5.3	MEASUREMENT EQUIPMENT USED .....	11
5.4	CONDUCTED EMISSION LIMIT .....	11
5.5	MEASUREMENT RESULT .....	11
5.6	CONDUCTED MEASUREMENT PHOTOS: .....	14
<b>6</b>	<b>RADIATED EMISSION TEST.....</b>	<b>15</b>
6.1	MEASUREMENT PROCEDURE.....	15
6.2	TEST SET-UP (BLOCK DIAGRAM OF CONFIGURATION) .....	15
6.3	MEASUREMENT EQUIPMENT USED .....	16
6.4	RADIATED EMISSION LIMIT.....	16
6.5	MEASUREMENT RESULT .....	18
6.6	RADIATED MEASUREMENT PHOTOS: .....	23
<b>7</b>	<b>FREQUENCY STABILITY MEASUREMENT .....</b>	<b>24</b>
7.1	FREQUENCY STABILITY LIMITS.....	24
7.2	MEASUREMENT INSTRUMENTS LIST .....	24
7.3	TEST PROCEDURE.....	24
7.4	EUT OPERATING CONDITIONS .....	24
7.5	TEST RESULTS.....	25
<b>8</b>	<b>EMISSION BANDWIDTH.....</b>	<b>32</b>
8.1	EMISSION BANDWIDTH LIMIT.....	32
8.2	TEST INSTRUMENTS.....	32
8.3	TEST PROCEDURE .....	32
8.4	TEST SETUP.....	32
8.5	TEST RESULT .....	32
<b>9</b>	<b>ANTENNA REQUIREMENT.....</b>	<b>34</b>
9.1	RESULT .....	34

# 1 General Information

## 1.1 Product Description

Characteristics	Description
<b>EUT:</b>	Fingerprint Access Controller
<b>Modulation:</b>	ASK
<b>Operating Frequency:</b>	13.56MHz
<b>Number of Channels:</b>	1 channel
<b>Antenna Type :</b>	Internal loop antenna
<b>Input rating:</b>	AC 100-240V, 50/60Hz, 1.2A
<b>Power supply:</b>	AC 120V/60Hz
<b>Adapter:</b>	MODEL: DSA-42PFB-12 1 120350 INPUT: 100-240V~50/60Hz 1.2A OUTPUT: DC12V, 3.5A

Note: for a more detailed features description, please refer to the manufacturer's specifications or the User's Manual.

## 1.2 Related Submittal(s) / Grant(s)

This submittal(s) (test report) is intended for FCC ID: XX2-T9 filing to comply with Section 15.209 and 15.225 of the FCC Part 15, Subpart C Rules.

### 1.3 Test Methodology

Both conducted and radiated testing was performed according to the procedures in ANSI C63.10-2013. Radiated testing was performed at an antenna to EUT distance 3 meters.

### 1.4 Special Accessories

There is a USB cable with two ferrite cores in this submission.

### 1.5 Equipment Modifications

Not available for this EUT intended for grant.

### 1.6 Test Facility

Site Description  
EMC Lab. :

Accredited by CNAS, 2016.10.24  
The certificate is valid until 2022.10.28  
The Laboratory has been assessed and proved to be in compliance with CNAS-CL01:2006 (identical to ISO/IEC 17025:2005)  
The Certificate Registration Number is L2291.

Accredited by TUV Rheinland Shenzhen 2016.5.19  
The Laboratory has been assessed according to the requirements ISO/IEC 17025.

Accredited by FCC, August 03, 2017  
Designation Number: CN1204  
Test Firm Registration Number: 882943

Accredited by Industry Canada, November 24, 2015  
The Certificate Registration Number is 4480A.

Name of Firm : Accredited by A2LA, July 31, 2017  
The Certificate Number is 4321.01  
EMTEK(SHENZHEN)CO., LTD.  
Site Location : Bldg 69, Majialong Industry Zone, Nanshan District,  
Shenzhen, Guangdong, China

## **2 System Test Configuration**

### **2.1 EUT Configuration**

The EUT configuration for testing is installed on RF field strength measurement to meet the Commissions requirement and operating in a manner which intends to maximize its emission characteristics in a continuous normal application.

### **2.2 EUT Exercise**

The Transmitter was operated in the normal operating mode. The TX frequency was fixed which was for the purpose of the measurements.

### **2.3 Test Procedure**

#### **2.3.1 Conducted Emissions**

The EUT is a placed on as turn table which is 0.8 m above ground plane. According to the requirements in Section 13.1.4.1 of ANSI C63.10-2013 Conducted emissions from the EUT measured in the frequency range between 0.15 MHz and 30 MHz using CISPR Quasi-Peak and average detector mode.

#### **2.3.2 Radiated Emissions**

The EUT is a placed on as turn table which is 0.8 m above ground plane. The turn table shall rotate 360 degrees to determine the position of maximum emission level. EUT is set 3m away from the receiving antenna which varied from 1m to 4m to find out the highest emission. And also, each emission was to be maximized by changing the polarization of receiving antenna both horizontal and vertical. In order to find out the max. emission, the relative positions of this transmitter(EUT) was tested according to the requirements in Section 13.1.4.1 of ANSI C63.10-2013.

## 2.4 Configuration of Tested System

**Fig. 2-1 Configuration of Tested System**

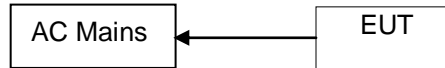

**Table 2-1 Equipment Used in Tested System**

Item	Equipment	Mfr/Brand	Model/Type No.	FCC ID	Series No.	Note
1	Fingerprint Access Controller	NITGEN	eNBioAccess-T9	XX2-T9	N/A	<b><i>EUT</i></b>
2	Switching Adapter	DVE	DSA-42PFB-121 120350	N/A	N/A	<b><i>Support EUT</i></b>

**Note:**

- (1) Unless otherwise denoted as EUT in 『Remark』 column, device(s) used in tested system is a support equipment.



### 3 Summary of Test Results

FCC Rules	Description Of Test	Result
§15.207	AC Power Conducted Emission	Complied*
§15.225(a)(b)(c), (d), §15.209	Radiated Emission	Complied*
§15.225(e)	Frequency Stability	Complied*
§15.203	Antenna Application	Complied*
All the test data was the same to the another report NO.: ES181203026E2 since their products are the same. The differences between them are the Applicant, Manufacturer, FCC ID, Trade Mark, Product Name and model number.		

For Radiated: The EUT's antenna was pre-tested under the following modes:

Test Mode	Description
Mode A	X-Y axis
Mode B	Y-Z axis
<b>Mode C</b>	<b>X-Z axis</b>

From the above modes, the worst case was found in Mode C. Therefore only the test data of the mode was recorded in this report.

#### 4 TEST SYSTEM UNCERTAINTY

The following measurement uncertainty levels have been estimated for tests performed on the apparatus:

Parameter	Uncertainty
Radio Frequency	$\pm 1 \times 10^{-5}$
Maximum Peak Output Power Test	$\pm 1.0\text{dB}$
Conducted Emissions Test	$\pm 2.0\text{dB}$
Radiated Emission Test	$\pm 2.0\text{dB}$
Power Density	$\pm 2.0\text{dB}$
Occupied Bandwidth Test	$\pm 1.0\text{dB}$
Band Edge Test	$\pm 3\text{dB}$
All emission, radiated	$\pm 3\text{dB}$
Antenna Port Emission	$\pm 3\text{dB}$
Temperature	$\pm 0.5^\circ\text{C}$
Humidity	$\pm 3\%$

Remark: The coverage Factor ( $k=2$ ), and measurement Uncertainty for a level of Confidence of 95%

## 5 Conducted Emissions Test

### 5.1 Measurement Procedure

1. The EUT was placed on a table which is 0.8m above ground plane.
2. Maximum procedure was performed on the six highest emissions to ensure EUT compliance.
3. Repeat above procedures until all frequency measured was complete.

### 5.2 Test SET-UP (Block Diagram of Configuration)

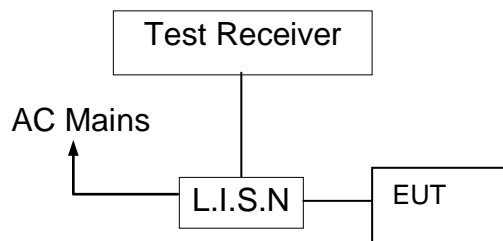

### 5.3 Measurement Equipment Used

Conducted Emission Test Site						
EQUIPMENT TYPE	MFR	MODEL NUMBER	SERIAL NUMBER	Characteristics	Last Cal.	Cal. Interval
Test Receiver	Rohde & Schwarz	ESCS30	828985/018	9kHz~3GHz	05/16/2018	05/15/2019
Artificial Network	Schwarzbeck	8126D	8126D-211	9KHz-300MHz	05/16/2018	05/15/2019
RF Switching Unit	CDS	RSU-M2	38401	9KHz-300MHz	05/16/2018	05/15/2019
Coaxial Cable	CDS	79254	46107086	9kHz~3GHz	05/16/2018	05/15/2019

### 5.4 Conducted Emission Limit

Conducted Emission Frequency(MHz)	Quasi-peak	Average
0.15-0.5	66-56	56-46
0.5-5.0	56	46
5.0-30.0	60	50

- Note:**
1. The lower limit shall apply at the transition frequencies
  2. The limit decreases in line with the logarithm of the frequency in the range of 0.15 to 0.50MHz.

### 5.5 Measurement Result

Pass.

Please refer to the following pages.

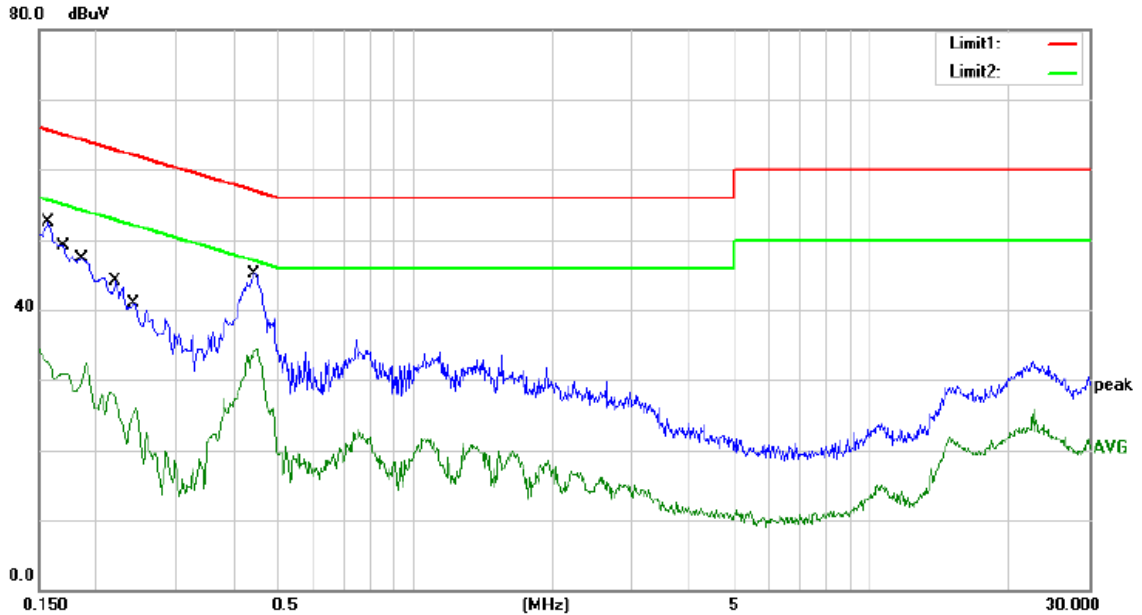

Site site #1 Phase: **L1** Temperature: 25  
 Limit: (CE)FCC PART 15 C\_QP Power: AC 120V/60Hz Humidity: 55 %  
 Mode: TX(13.56MHz)  
 Note:

No.	Mk.	Freq. MHz	Reading Level dBuV	Correct Factor dB	Measure- ment dBuV	Limit dBuV	Over dB	Detector	Comment
1		0.1580	39.52	10.01	49.53	65.57	-16.04	QP	
2		0.1580	24.22	10.01	34.23	55.57	-21.34	AVG	
3		0.1700	36.18	10.02	46.20	64.96	-18.76	QP	
4		0.1700	20.94	10.02	30.96	54.96	-24.00	AVG	
5		0.1860	34.29	10.03	44.32	64.21	-19.89	QP	
6		0.1860	22.55	10.03	32.58	54.21	-21.63	AVG	
7		0.2220	30.97	10.04	41.01	62.74	-21.73	QP	
8		0.2220	18.32	10.04	28.36	52.74	-24.38	AVG	
9		0.2420	27.94	10.05	37.99	62.03	-24.04	QP	
10		0.2420	16.09	10.05	26.14	52.03	-25.89	AVG	
11		0.4460	31.91	10.15	42.06	56.95	-14.89	QP	
12	*	0.4460	24.12	10.15	34.27	46.95	-12.68	AVG	

\*:Maximum data    x:Over limit    !:over margin    Comment: Factor build in receiver.    Operator: Yaping Shen

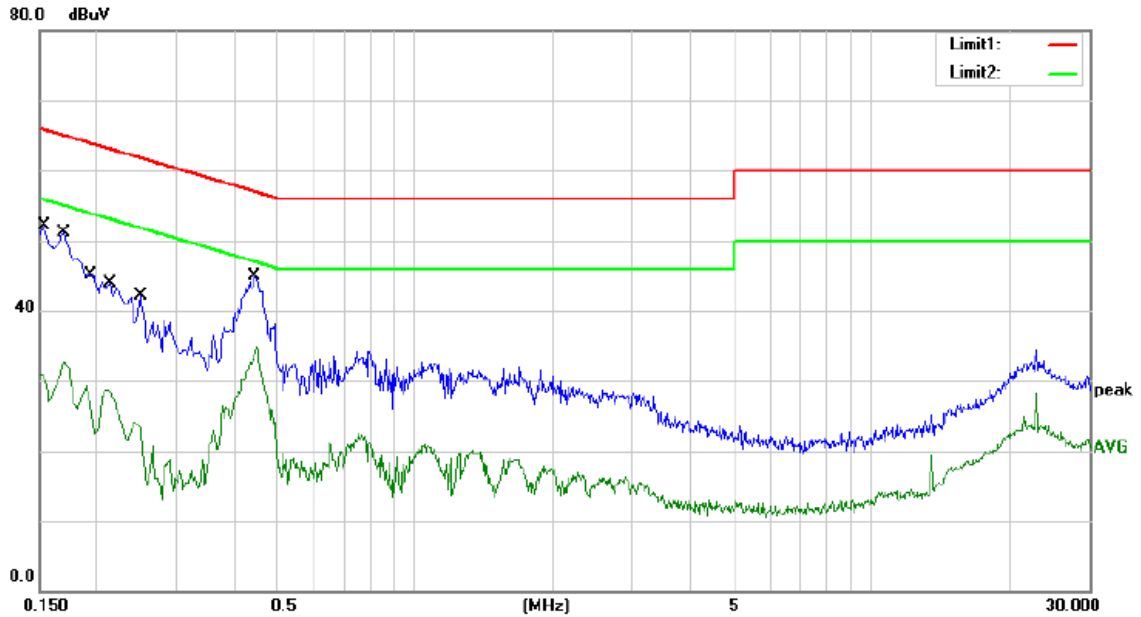

Site site #1  
 Limit: (CE)FCC PART 15 C\_QP  
 Mode: TX(13.56MHz)  
 Note:

Phase: **N**      Temperature: 25  
 Power: AC 120V/60Hz      Humidity: 55 %

No.	Mk.	Freq. MHz	Reading Level dBuV	Correct Factor dB	Measure- ment dBuV	Limit dBuV	Over dB	Detector	Comment
1		0.1540	39.17	10.01	49.18	65.78	-16.60	QP	
2		0.1540	20.95	10.01	30.96	55.78	-24.82	AVG	
3		0.1700	39.18	10.02	49.20	64.96	-15.76	QP	
4		0.1700	22.76	10.02	32.78	54.96	-22.18	AVG	
5		0.1940	31.99	10.03	42.02	63.86	-21.84	QP	
6		0.1940	19.20	10.03	29.23	53.86	-24.63	AVG	
7		0.2140	30.78	10.04	40.82	63.05	-22.23	QP	
8		0.2140	18.69	10.04	28.73	53.05	-24.32	AVG	
9		0.2500	29.04	10.06	39.10	61.76	-22.66	QP	
10		0.2500	14.05	10.06	24.11	51.76	-27.65	AVG	
11		0.4460	31.77	10.15	41.92	56.95	-15.03	QP	
12	*	0.4460	24.74	10.15	34.89	46.95	-12.06	AVG	

\*:Maximum data    x:Over limit    !:over margin    Comment: Factor build in receiver.    Operator: Yaping Shen

**5.6 Conducted Measurement Photos:**



## 6 Radiated Emission Test

### 6.1 Measurement Procedure

1. The EUT was placed on a turn table which is 0.8m above ground plane.
2. Maximum procedure was performed on the six highest emissions to ensure EUT compliance.
3. And also, each emission was to be maximized by changing the polarization of receiving antenna both horizontal and vertical.
4. Repeat above procedures until all frequency measured were complete.

### 6.2 Test SET-UP (Block Diagram of Configuration)

(A) Radiated Emission Test Set-Up, Frequency Below 30MHz

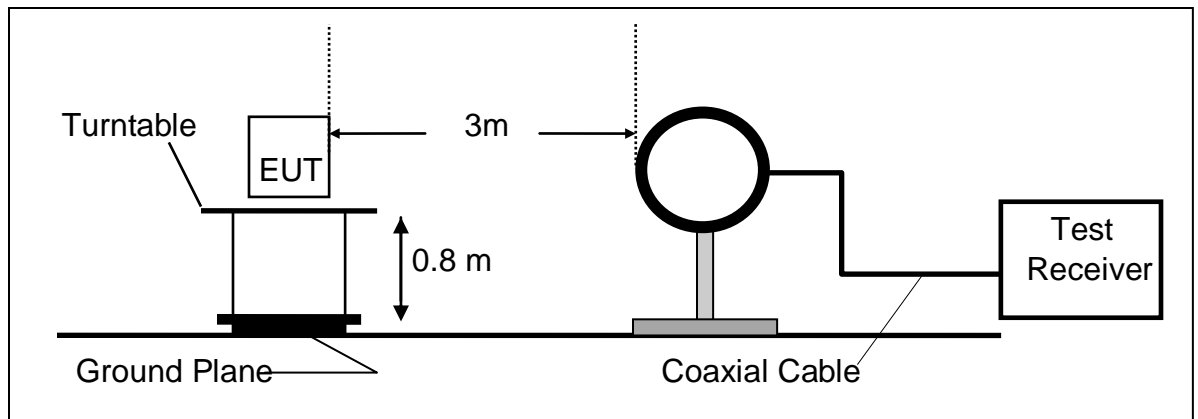

(B) Radiated Emission Test Set-Up, Frequency Below 1000MHz

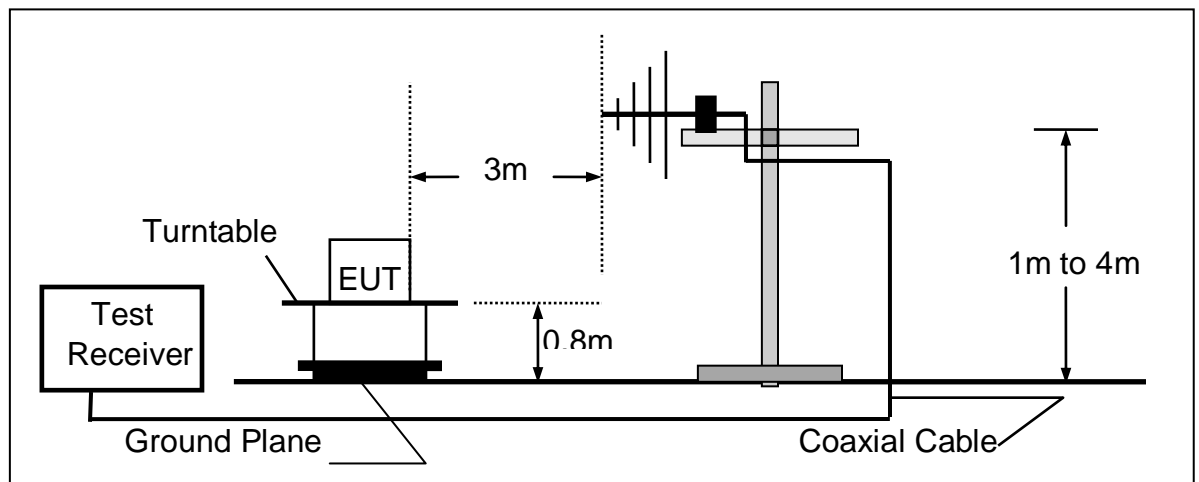

### 6.3 Measurement Equipment Used

Item	Equipment	Manufacturer	Model No.	Serial No.	Characteristics	Last Cal.	Cal. Interval
1.	Test Receiver	Rohde & Schwarz	ESCI	1166.5950.03	9KHz-3GHz	05/16/2018	1 Year
2.	Loop Antenna	Schwarzbeck	FMZB 1519	012	9 KHz -30MHz	05/16/2018	1 Year
3.	Bilog Antenna	Schwarzbeck	VULB9163	000141	25MHz-2GHz	05/16/2018	1 Year
4.	Power Amplifier	HP	8447F	OPT H64	9 KHz -1300MHz	05/16/2018	1 Year
5.	Color Monitor	SUNSPO	SP-140A	N/A	--	05/16/2018	1 Year
6.	Single Line Filter	JIANLI	XL-3	N/A	--	05/16/2018	1 Year
7.	Single Phase Power Line Filter	JIANLI	DL-2X100B	N/A	--	05/16/2018	1 Year
8.	3 Phase Power Line Filter	JIANLI	DL-4X100B	N/A	--	05/16/2018	1 Year
9.	DC Power Filter	JIANLI	DL-2X50B	N/A	--	05/16/2018	1 Year
10.	Cable	Schwarzbeck	PLF-100	549489	9KHz-3GHz	05/16/2018	1 Year
11.	Cable	Rosenberger	CIL02	A0783566	9KHz-3GHz	05/16/2018	1 Year
12.	Cable	Rosenberger	RG 233/U	525178	9KHz-3GHz	05/16/2018	1 Year

### 6.4 Radiated Emission Limit

The emissions from an intentional radiator shall not exceed the field strength levels specified in the following table 15.209(a):

FCC Part 15.209				
Frequency (MHz)	Field Strength Limitation		Field Strength Limitation Frequency at 3m Measurement Distance	
	(uV/m)	Dist	(uV/m)	(dBuV/m)
0.009 – 0.490	2400 / F(KHz)	300m	10000 * 2400/F(KHz)	20log 2400/F(KHz) + 80
0.490 – 1.705	24000 / F(KHz)	30m	100 * 24000/F(KHz)	20log 24000/F(KHz) + 40
1.705 – 30.00	30	30m	100* 30	20log 30 + 40
30.0 – 88.0	100	3m	100	20log 100
88.0 – 216.0	150	3m	150	20log 150
216.0 – 960.0	200	3m	200	20log 200
Above 960.0	500	3m	500	20log 500



FCC Part 15.225(a)/(b)/(c)				
Frequency (MHz)	Field Strength Limitation		Field Strength Limitation Frequency tion at 3m Measurement Dist	
	(uV/m)	Dist	(uV/m)	(dBuV/m)
13.110 – 13.410	106	30 m	106*100	80.5
13.410 – 13.553	334	30 m	334*100	90.5
13.553 – 13.567	15,848	30 m	15,848*100	124
13.567 – 13.710	334	30 m	334*100	90.5
13.710 – 14.010	106	30 m	106*100	80.5

15.205 Restricted bands of operation

MHz	MHz	MHz	GHz
0.090 - 0.110	16.42 - 16.423	399.9 - 410	4.5 - 5.15
<sup>1</sup> 0.495 - 0.505	16.69475 - 16.69525	608 - 614	5.35 - 5.46
2.1735 - 2.1905	16.80425 - 16.80475	960 - 1240	7.25 - 7.75
4.125 - 4.128	25.5 - 25.67	1300 - 1427	8.025 - 8.5
4.17725 - 4.17775	37.5 - 38.25	1435 - 1626.5	9.0 - 9.2
4.20725 - 4.20775	73 - 74.6	1645.5 - 1646.5	9.3 - 9.5
6.215 - 6.218	74.8 - 75.2	1660 - 1710	10.6 - 12.7
6.26775 - 6.26825	108 - 121.94	1718.8 - 1722.2	13.25 - 13.4
6.31175 - 6.31225	123 - 138	2200 - 2300	14.47 - 14.5
8.291 - 8.294	149.9 - 150.05	2310 - 2390	15.35 - 16.2
8.362 - 8.366	156.52475 - 156.52525	2483.5 - 2500	17.7 - 21.4
8.37625 - 8.38675	156.7 - 156.9	2690 - 2900	22.01 - 23.12
8.41425 - 8.41475	162.0125 - 167.17	3260 - 3267	23.6 - 24.0
12.29 - 12.293	167.72 - 173.2	3332 - 3339	31.2 - 31.8
12.51975 - 12.52025	240 - 285	3345.8 - 3358	36.43 - 36.5
12.57675 - 12.57725	322 - 335.4	3600 - 4400	( <sup>2</sup> )

- Remark 1. Emission level in dBuV/m=20 log (uV/m)  
: 2. Measurement was performed at an antenna to the closed point of EUT distance of meters.  
3. Only spurious frequency is permitted to locate within the Restricted Bands specified in provision of § 15.205, and the emissions located in restricted bands also comply with 15.209 limit.

### 6.5 Measurement Result

Please refer to the following pages.

Operation Mode: TX Mode(13.56MHz) Test Date : December 12, 2018  
 Frequency Range: 9kHz~30MHz Temperature : 20°C  
 Test Result: PASS Humidity : 63 %  
 Measured Distance: 3m Test By: Yaping Shen

Freq. (MHz)	Ant.Pol. H/V	Emission Level (dBuV/m)	Limit 3m (dBuV/m)	Over (dB)	Note
7.58	V	32.14	69.54	-37.4	QP
10.53	V	33.09	69.54	-36.45	QP
11.68	V	35.72	69.54	-33.82	QP
14.42	V	36.23	69.54	-33.31	QP
15.61	V	37.81	69.54	-31.73	QP
23.12	V	40.48	69.54	-29.06	QP
10.23	H	31.88	69.54	-37.66	QP
11.47	H	32.79	69.54	-36.75	QP
13.36	H	36.95	69.54	-32.59	QP
20.49	H	37.06	69.54	-32.48	QP
21.34	H	38.25	69.54	-31.29	QP
29.87	H	44.63	69.54	-24.91	QP

Operation Mode: TX Mode(13.56MHz) Test Date : December 12, 2018  
 Frequency Range: 30~1000MHz Temperature : 20°C  
 Test Result: PASS Humidity : 63 %  
 Measured Distance: 3m Test By: Yaping Shen

Freq. (MHz)	Ant.Pol. H/V	Emission Level (dBuV/m)	Limit 3m (dBuV/m)	Over (dB)	Note
384.0500	V	36.81	46	-9.19	QP
480.0800	V	36.98	46	-9.02	QP
551.8600	V	35.74	46	-10.26	QP
600.3600	V	37.10	46	-8.9	QP
624.6100	V	35.93	46	-10.07	QP
816.6700	V	35.76	46	-10.24	QP
384.0500	H	34.78	46	-11.22	QP
408.3000	H	34.94	46	-11.06	QP
455.8300	H	36.25	46	-9.75	QP
480.0800	H	38.31	46	-7.69	QP
720.6400	H	31.84	46	-14.16	QP
800.1800	H	36.27	46	-9.73	QP

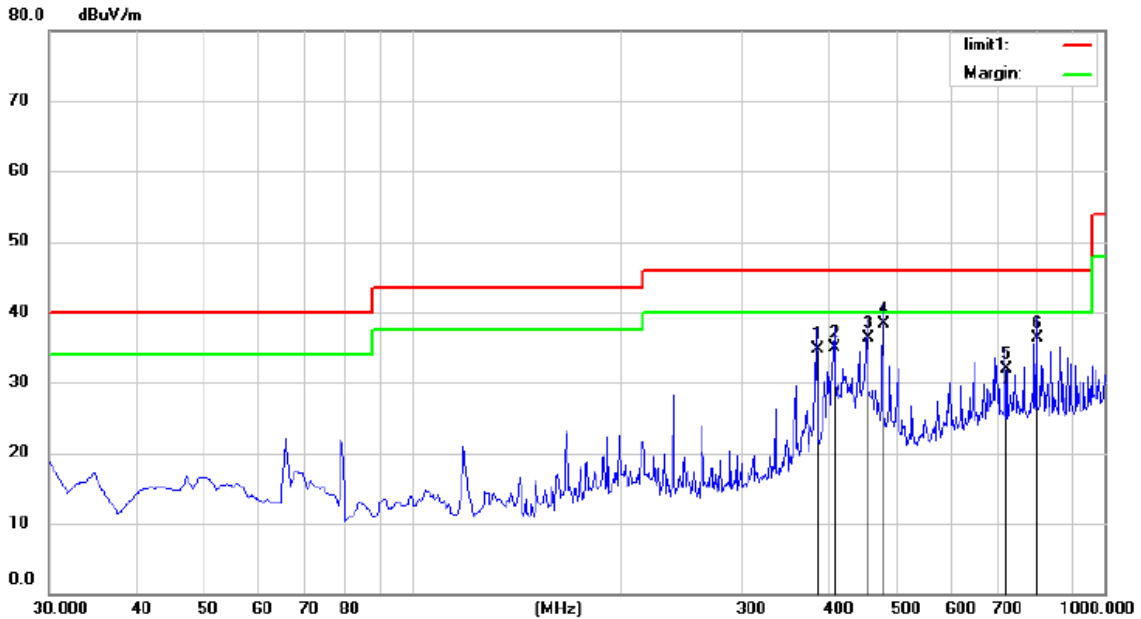

Site Chamber #1      Polarization: **Horizontal**      Temperature: 26  
 Limit: (RE)FCC PART 15 C 3m      Power: AC 120V/60Hz      Humidity: 55 %  
 Mode:TX(13.56MHz)  
 Note:

No.	Mk.	Freq.	Reading Level	Correct Factor	Measurement	Limit	Over	Antenna Height	Table Degree	
		MHz	dBuV	dB	dBuV/m	dBuV/m	dB	cm	degree	Comment
1		384.0500	46.06	-11.28	34.78	46.00	-11.22	QP		
2		408.3000	45.79	-10.85	34.94	46.00	-11.06	QP		
3		455.8300	46.10	-9.85	36.25	46.00	-9.75	QP		
4	*	480.0800	47.72	-9.41	38.31	46.00	-7.69	QP		
5		720.6400	35.99	-4.15	31.84	46.00	-14.16	QP		
6		800.1800	39.56	-3.29	36.27	46.00	-9.73	QP		

\*:Maximum data    x:Over limit    !:over margin

Operator: Yaping Shen

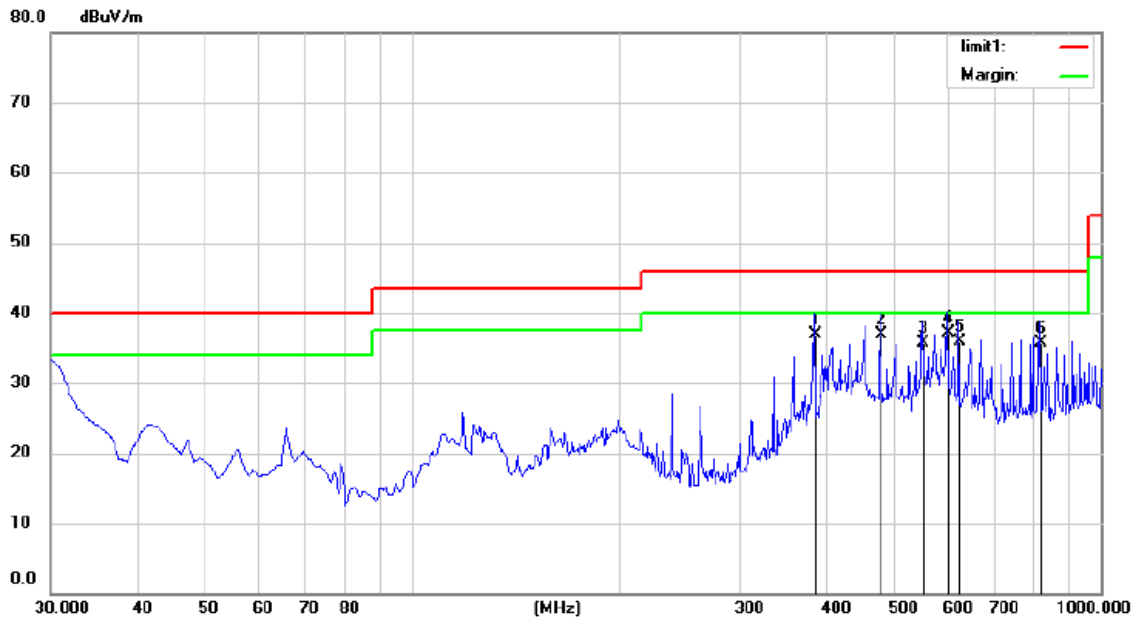

Site Chamber #1 Polarization: **Vertical** Temperature: 26  
 Limit: (RE)FCC PART 15 C 3m Power: AC 120V/60Hz Humidity: 55 %  
 Mode: TX(13.56MHz)  
 Note:

No.	Mk.	Freq. MHz	Reading Level dBuV	Correct Factor dB	Measure- ment dBuV/m	Limit dBuV/m	Over dB	Antenna Height cm	Table Degree	Detector	Comment
1		384.0500	48.83	-12.02	36.81	46.00	-9.19			QP	
2		480.0800	46.99	-10.01	36.98	46.00	-9.02			QP	
3		551.8600	43.84	-8.10	35.74	46.00	-10.26			QP	
4	*	600.3600	44.44	-7.34	37.10	46.00	-8.90			QP	
5		624.6100	43.01	-7.08	35.93	46.00	-10.07			QP	
6		816.6700	39.81	-4.05	35.76	46.00	-10.24			QP	

\*:Maximum data x:Over limit !:over margin

Operator: Yaping Shen

Operation Mode: TX Mode  
 Frequency Range: 13.560 MHz  
 Test Result: PASS  
 Measured Distance: 3m

Test Date : December 22, 2018  
 Temperature : 24°C  
 Humidity : 62 %  
 Test By: Yaping Shen

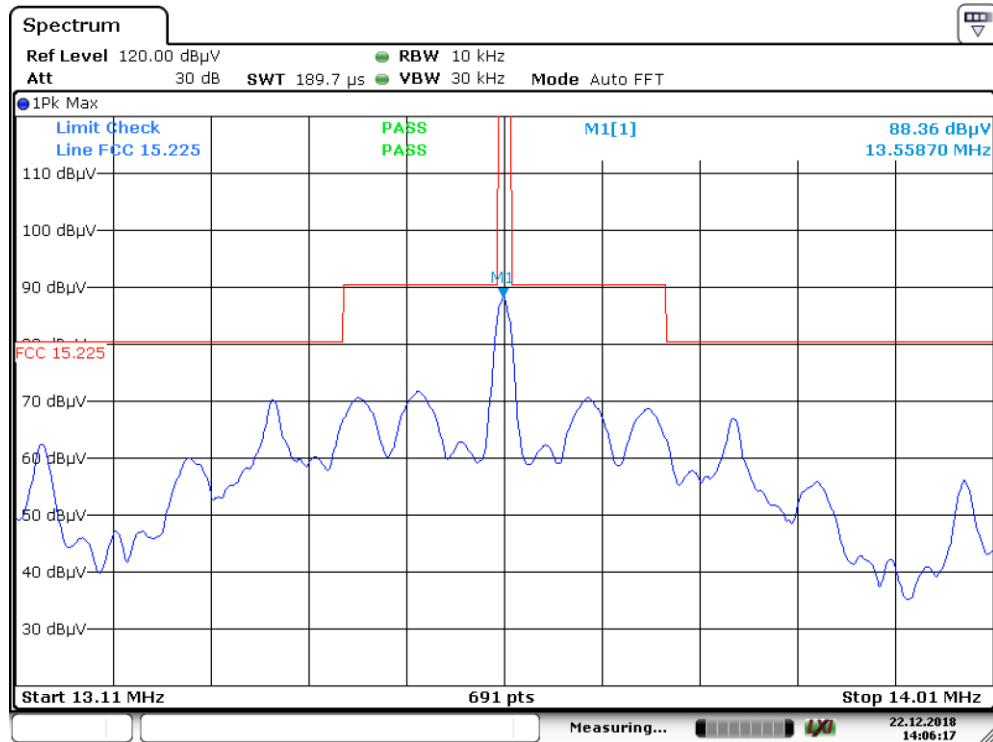

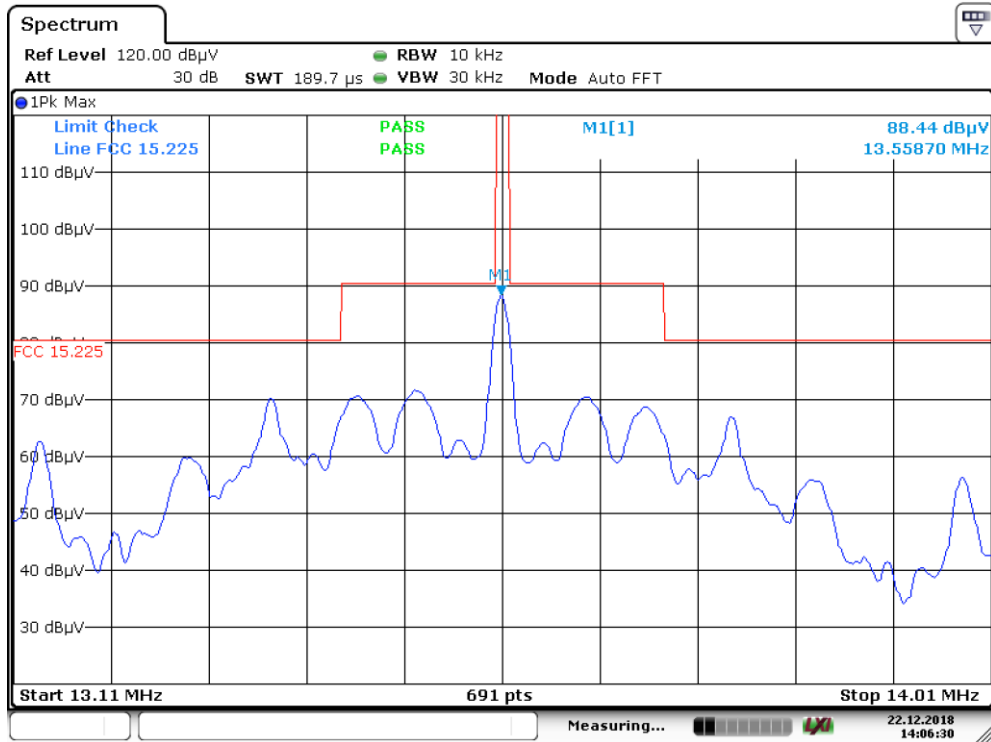



**6.6 Radiated Measurement Photos:**

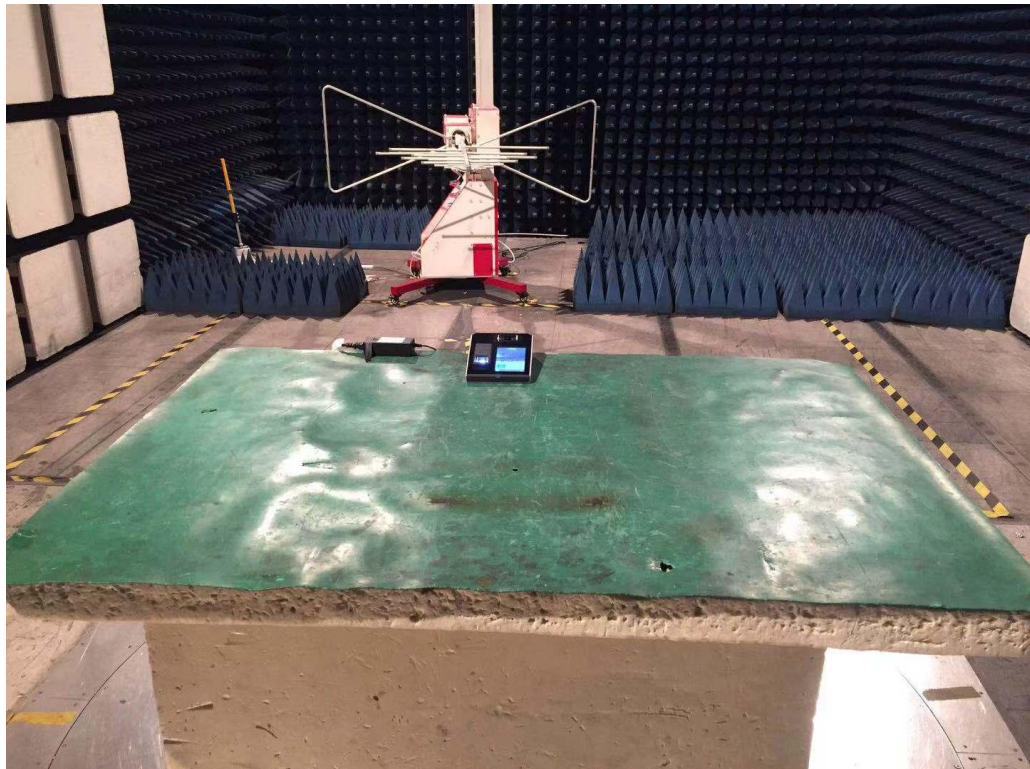
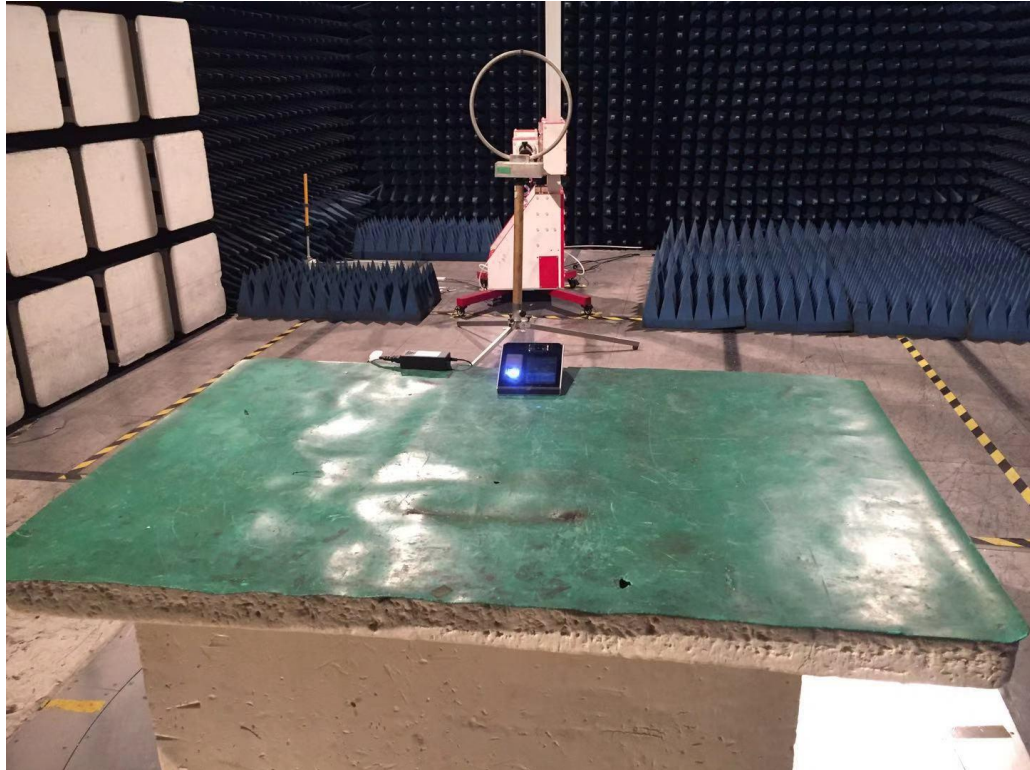

## 7 FREQUENCY STABILITY MEASUREMENT

### 7.1 FREQUENCY STABILITY LIMITS

FCC Part 15.225(e)

the frequency tolerance of the carrier signal shall be maintained within +/-0.01% of the operating frequency over a temperature variation of -20 degrees to + 50 degrees C at normal supply voltage, and for a variation in the primary supply voltage from 85% to 115% of the rated supply voltage at a temperature of 20 degrees C. For battery operated equipment, the equipment tests shall be performed using a new battery.

### 7.2 MEASUREMENT INSTRUMENTS LIST

EQUIPMENT TYPE	MFR	MODEL NUMBER	SERIAL NUMBER	Characteristics	LAST CAL.	CAL DUE.
Spectrum Analyzer	Rohde & Schwarz	FSV30	1321.3008K	10Hz-30GHz	05/16/2018	05/15/2019
Coaxial Cable	CDS	79254	46107086	10Hz-30GHz	05/16/2018	05/15/2019
Antenna Connector	ARTHUR-YANG	2244-N1TG1	N/A	10Hz-30GHz	05/16/2018	05/15/2019

Remark: The temporary antenna connector is soldered on the PCB board in order to perform conducted tests and this temporary antenna connector is listed in the equipment list.

### 7.3 TEST PROCEDURE

- a. The equipment under test was connected to an external AC power supply and the RF output was connected to a frequency counter via feed through attenuators. The EUT was placed inside the temperature chamber. After the temperature stabilized for approximately 20 minutes, the frequency of the output signal was recorded from the counter.
- b. At room temperature ( $25\pm 5^{\circ}\text{C}$ ), an external variable DC power supply was connected to the EUT. The frequency of the transmitter was measured for 115%, 100% and 85% of the nominal operating input voltage.
- c. For the actual test configuration, please refer to the related Item –EUT Test Photos.

### 7.4 EUT OPERATING CONDITIONS

The EUT tested system was configured as the statements of 4.1.6 Unless otherwise special operating condition is specified in the follows during the testing.



### 7.5 TEST RESULTS

E.U.T :	Fingerprint Access Controller(Rev.A)	Test Mode :	TX Mode
Test Voltage :	AC 120V		

Frequency Stability Versus Environmental Temperature					
Temperature (°C)	Voltage (Vac)	Frequency (MHz)	Freq Error (ppm)	Limit (ppm)	Results
-20	AC120V	13.56002750	2.03	100	PASS
-10	AC120V	13.56003750	2.77	100	PASS
0	AC120V	13.56003250	2.40	100	PASS
10	AC120V	13.56005750	4.24	100	PASS
20	AC120V	13.56006750	4.98	100	PASS
30	AC120V	13.56006750	4.98	100	PASS
40	AC120V	13.56009750	7.19	100	PASS
50	AC120V	13.56014250	10.51	100	PASS

Frequency Stability Versus Environmental Temperature

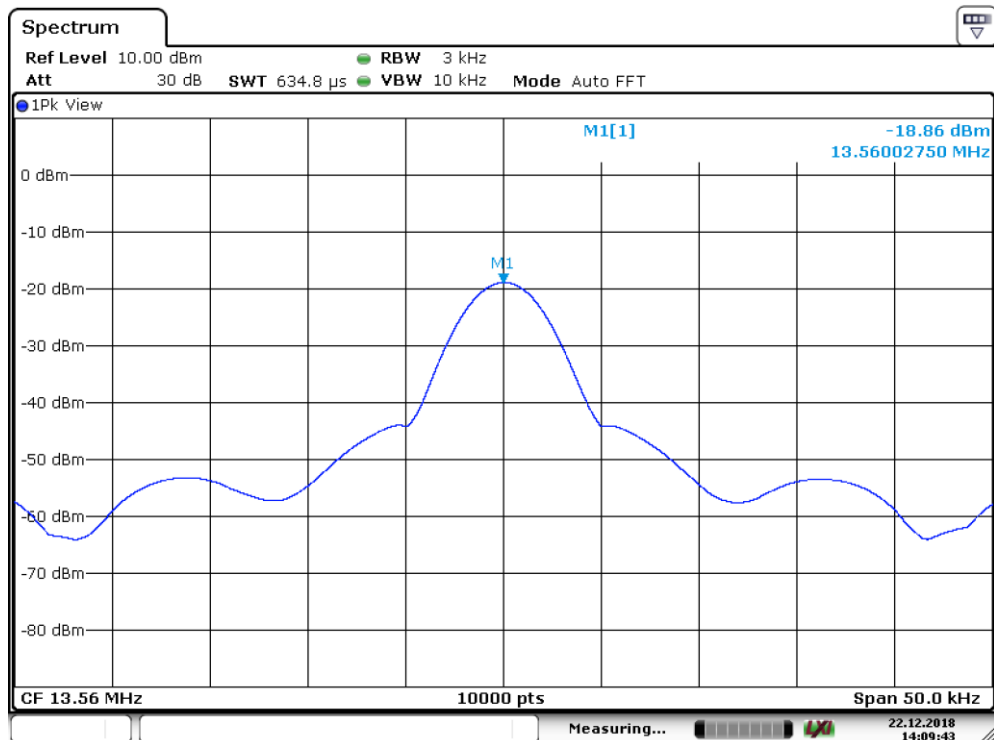

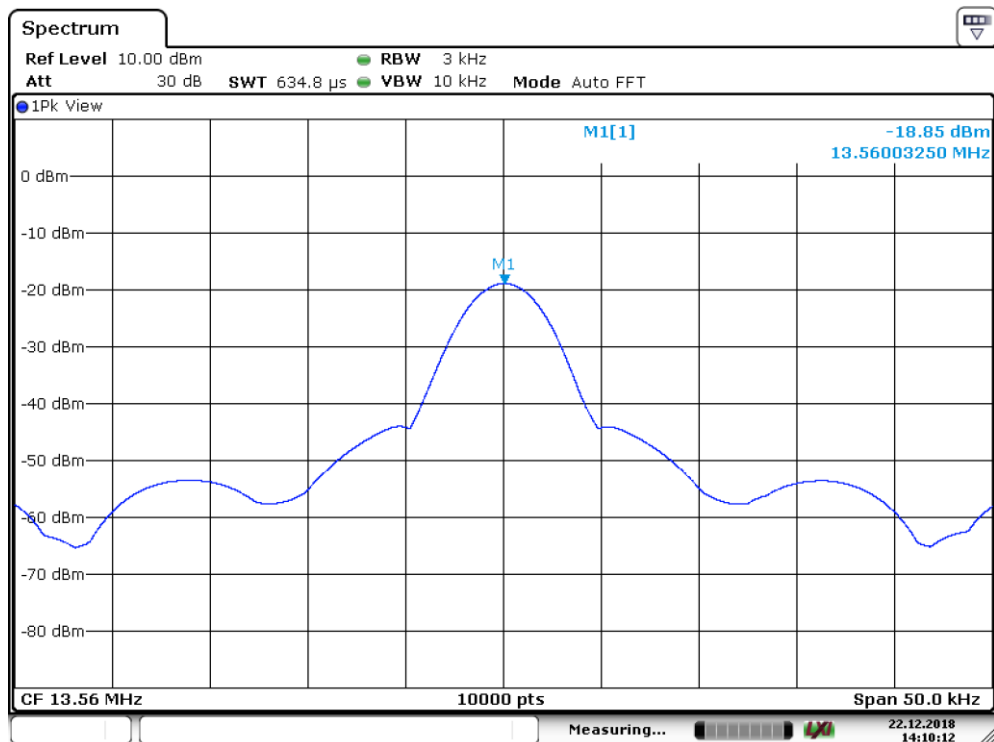
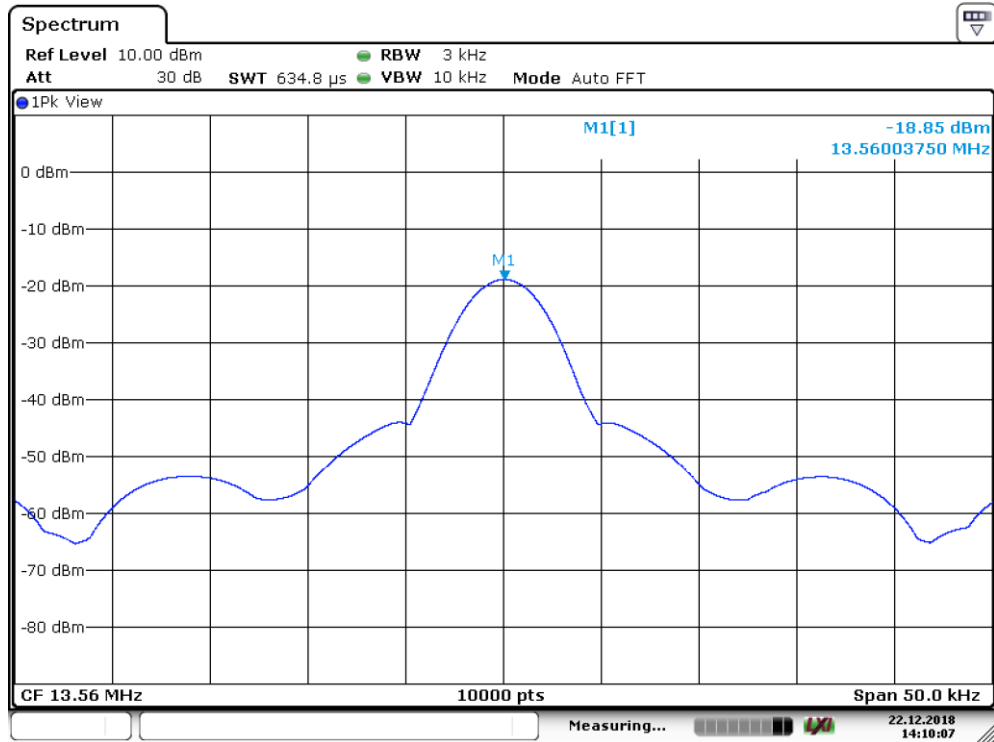

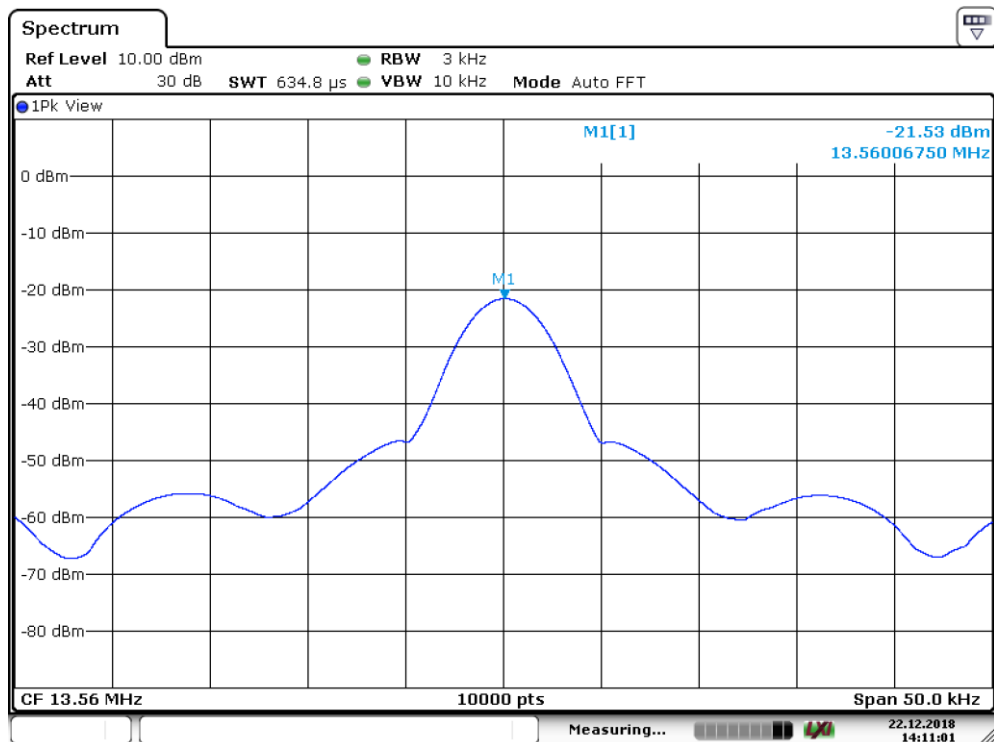
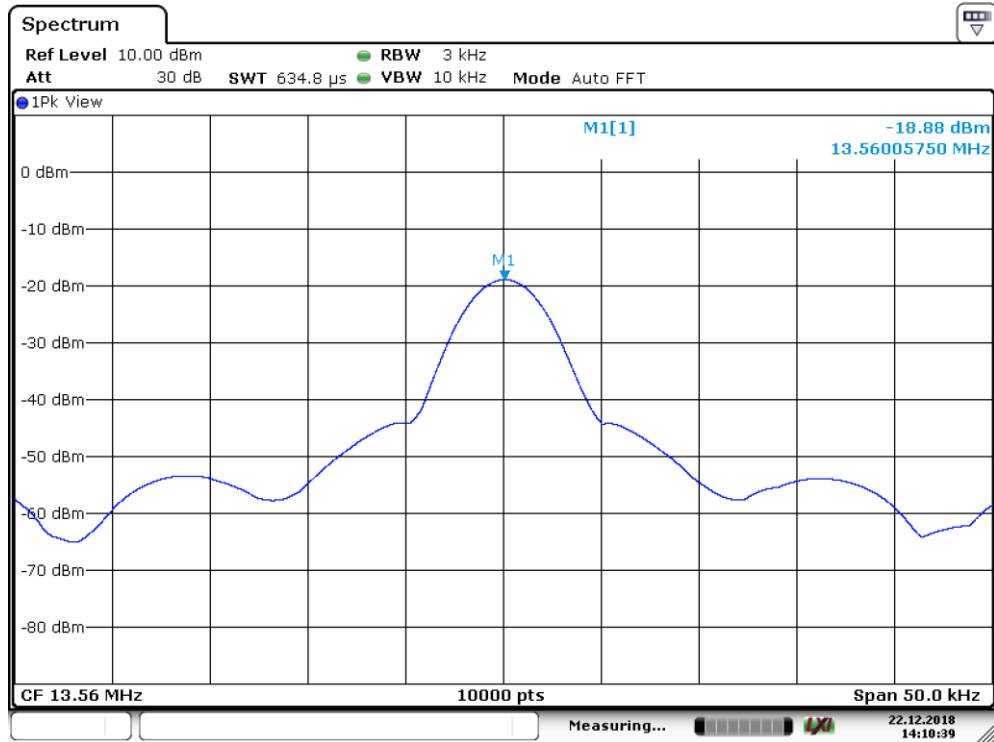

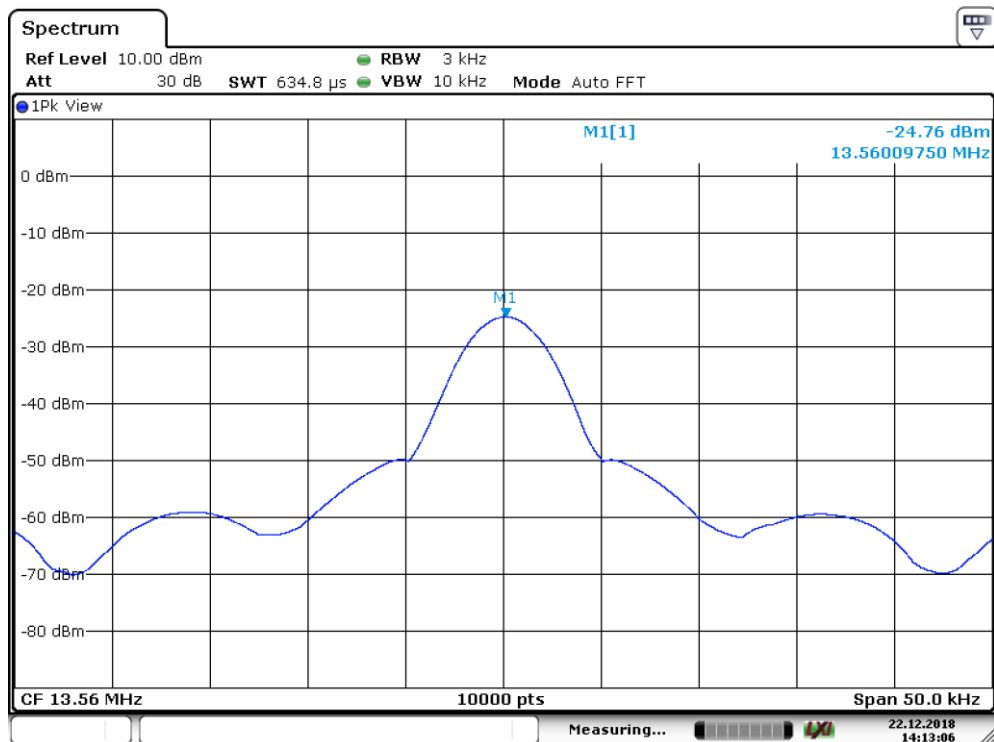
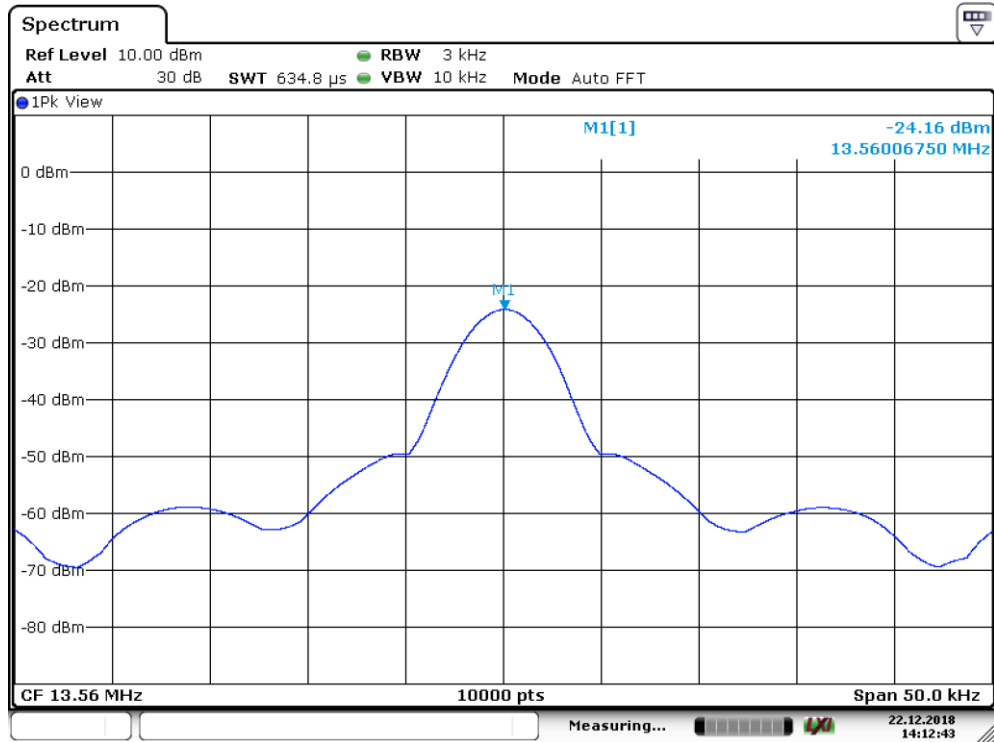

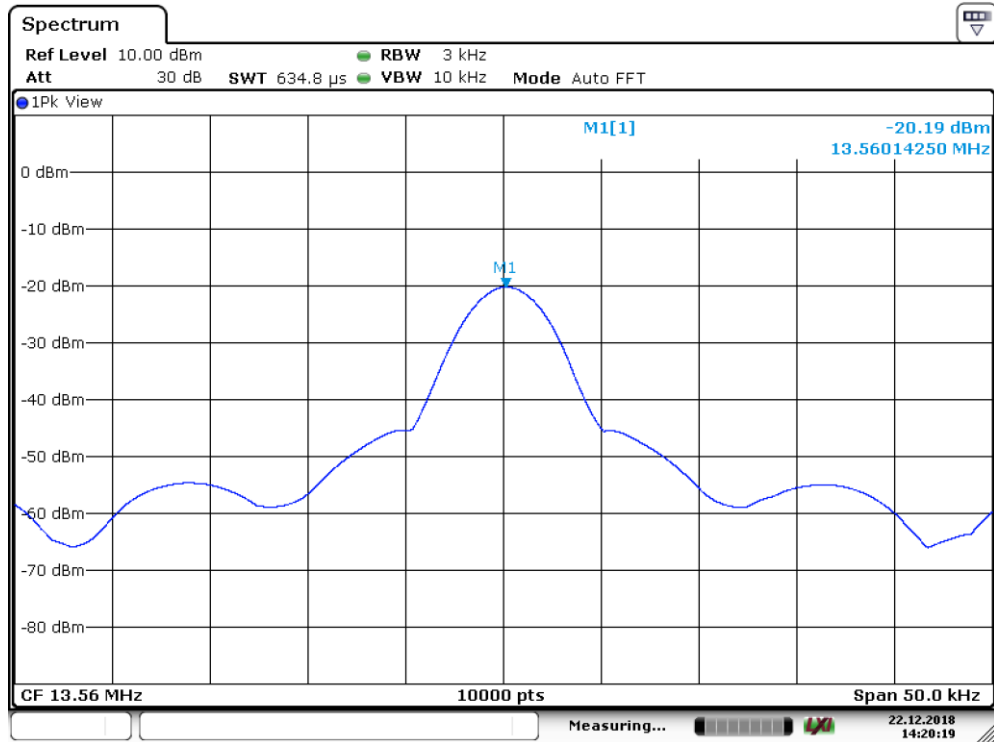

Frequency Stability Versus Input Voltage					
Temperature (°C)	Voltage (Vac)	Frequency (MHz)	Freq Error (ppm)	Limit (ppm)	Results
20	102V	13.56002250	1.66	100	PASS
20	120V	13.56002750	2.03	100	PASS
20	138V	13.56004250	3.13	100	PASS

**Frequency Stability Versus Input Voltage**

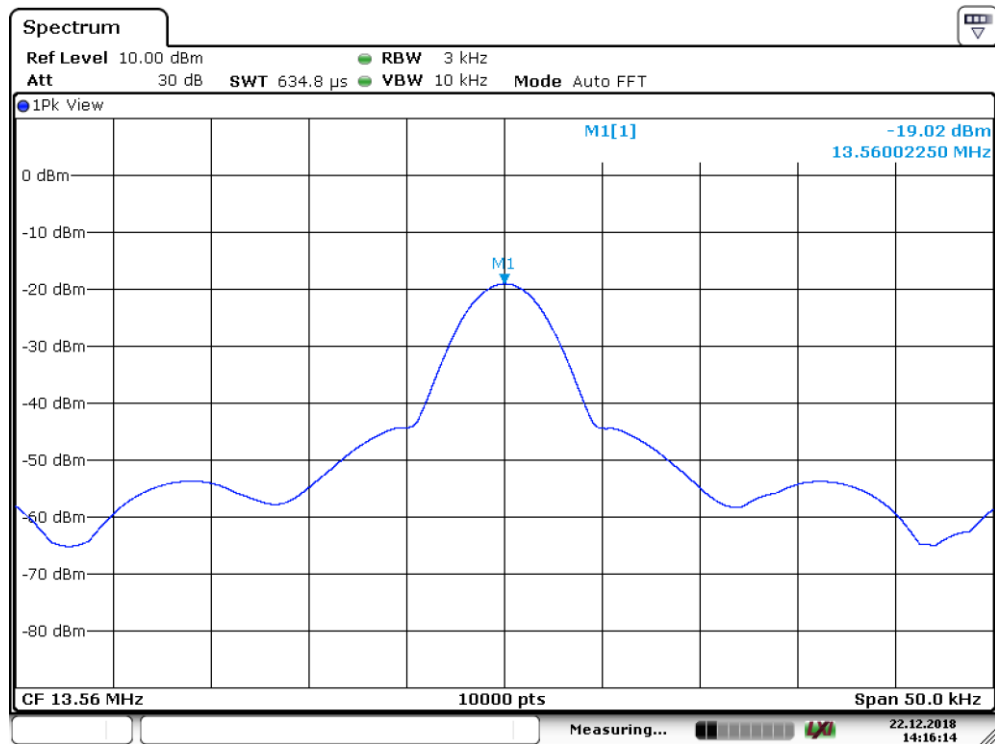

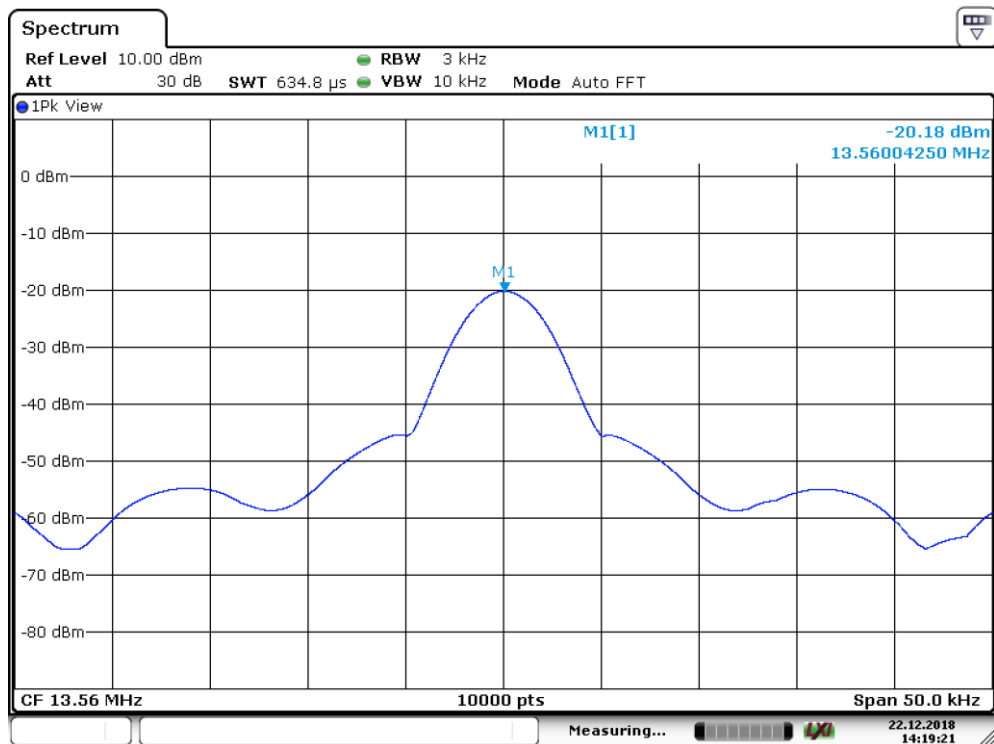
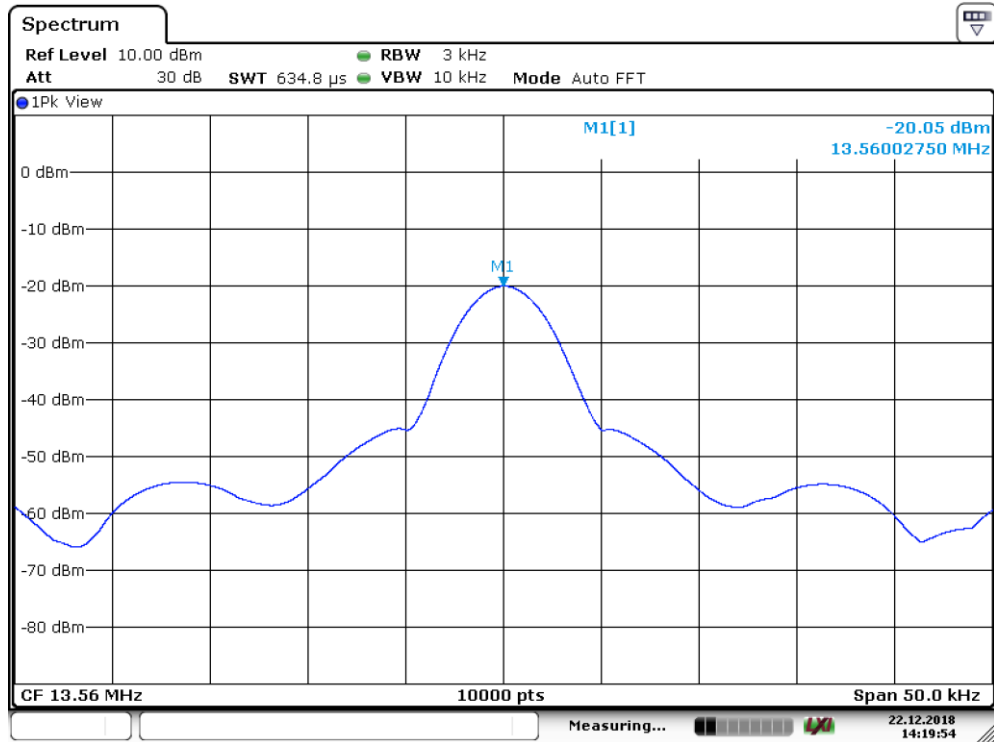

## 8 EMISSION BANDWIDTH

### 8.1 Emission Bandwidth Limit

Intentional radiators must be designed to ensure that the 20 dB bandwidth of the emissions in the specific band (13.553 – 13.567 MHz).

### 8.2 TEST INSTRUMENTS

Refer a test equipment and calibration data table in this test report.

### 8.3 TEST PROCEDURE

The bandwidth of the fundamental frequency was measured by spectrum analyzer with 3kHz RBW and 10kHz VBW. The 20dB bandwidth is defined as the total spectrum the power of which is higher than peak power minus 20dB.

### 8.4 Test Setup

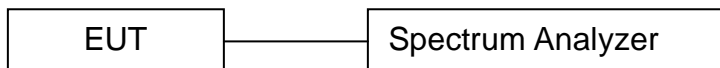

### 8.5 Test Result

Frequency (MHz)	20dB Bandwidth (kHz)	Results
13.56	8.177	PASS



## BANDWIDTH TEST PLOT

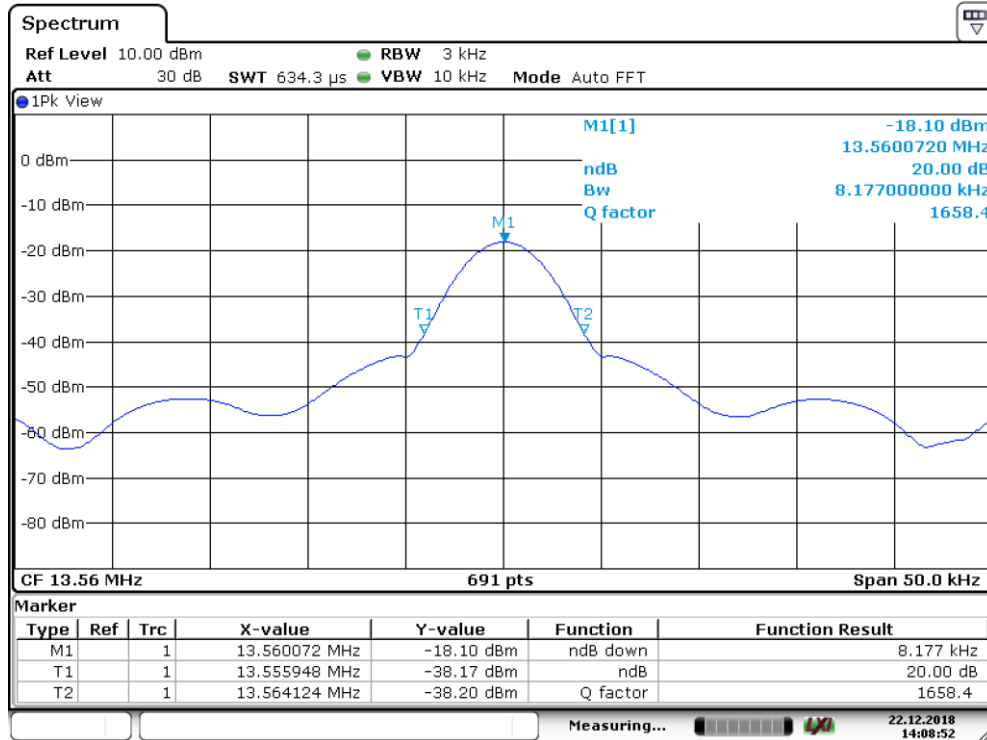

## **9 ANTENNA REQUIREMENT**

The EUT'S antenna is met the requirement of FCC part 15C section 15.203.

### **9.1 Result**

The EUT's antenna used an inter Loop Antenna and integral on the PCB. The antenna is permanently attached on PCB, no consideration of replacement. Please refer to internal Photos for details. So it meets the requirement.

-----END OF REPORT-----