



MET Laboratories, Inc. *Safety Certification - EMI - Telecom Environmental Simulation*

914 WEST PATAPSCO AVENUE • BALTIMORE, MARYLAND 21230-3432 • PHONE (410) 354-3300 • FAX (410) 354-3313
33439 WESTERN AVENUE • UNION CITY CALIFORNIA 94587 • PHONE (510) 489-6300 • FAX (510) 489-6372
3162 BELICK STREET • SANTA CLARA CALIFORNIA 95054 • PHONE (408) 748-3585 • FAX (510) 489-6372
13501 MCCALLEN PASS • AUSTIN TEXAS 78753 • PHONE (512) 287-2500 • FAX (512) 287-2513

February 10, 2016

Zebra Technologies Corporation
2940 N. 1st Street
San Jose, CA 95134

Dear Andrei Moldavanov,

Enclosed is the EMC test report for compliance testing of the Zebra Technologies Corporation, UWX100 as tested to the requirements of Title 47 of the CFR, Ch. 1 (10-1-03 ed.), Part 15 Subpart C, §15.250, and RSS-220, Issue 1, March 2009 for Wideband Operation.

Thank you for using the services of MET Laboratories, Inc. If you have any questions regarding these results or if MET can be of further service to you, please feel free to contact me.

Sincerely yours,
MET LABORATORIES, INC.

Jennifer Warnell
Documentation Department

Reference: (\Zebra Technologies Corporation\EMC87078-FCC250 Rev. 2)

Certificates and reports shall not be reproduced except in full, without the written permission of MET Laboratories, Inc. This letter of transmittal is not a part of the attached report.

DOC-EMC702 2/26/2004



MET Laboratories, Inc. *Safety Certification - EMI - Telecom Environmental Simulation*

914 WEST PATAPSCO AVENUE • BALTIMORE, MARYLAND 21230-3432 • PHONE (410) 354-3300 • FAX (410) 354-3313
33439 WESTERN AVENUE • UNION CITY CALIFORNIA 94587 • PHONE (510) 489-6300 • FAX (510) 489-6372
3162 BELICK STREET • SANTA CLARA CALIFORNIA 95054 • PHONE (408) 748-3585 • FAX (510) 489-6372
13501 MCCALLEN PASS • AUSTIN TEXAS 78753 • PHONE (512) 287-2500 • FAX (512) 287-2513

**Electromagnetic Compatibility Criteria
Test Report**

For the

**Zebra Technologies Corporation
UWX100**

Tested under
the FCC Certification Rules
contained in
Title 47 of the CFR, Part 15.250 Subpart C
&
RSS-220, Issue 1, March 2009
for Wideband Operation

MET Report: EMC87078-FCC250 Rev. 2

February 10, 2016

Prepared For:

**Zebra Technologies Corporation
2940 N. 1st Street
San Jose, CA 95134**

**Prepared By:
MET Laboratories, Inc.
914 W. Patapsco Ave.
Baltimore, MD 21230**



Electromagnetic Compatibility Criteria Test Report

For the

Zebra Technologies Corporation
UWX100

Tested under
the FCC Certification Rules
contained in
Title 47 of the CFR, Part 15.250 Subpart C
&
RSS-220, Issue 1, March 2009
for Wideband Operation

Djed Mouada, Project Engineer
Electromagnetic Compatibility Lab

Jennifer Warnell
Documentation Department

Engineering Statement: The measurements shown in this report were made in accordance with the procedures indicated, and the emissions from this equipment were found to be within the limits applicable. I assume full responsibility for the accuracy and completeness of these measurements, and for the qualifications of all persons taking them. It is further stated that upon the basis of the measurements made, the equipment tested is capable of operation in accordance with the requirements of Part 15.250 of the FCC Rules, and RSS-220 of the Industry Canada Rules under normal use and maintenance.

Asad Bajwa
Director, Electromagnetic Compatibility Lab



Report Status Sheet

| Revision | Report Date | Reason for Revision |
|----------|-------------------|---|
| ∅ | October 23, 2015 | Initial Issue. |
| 1 | October 27, 2015 | Customer changed their block diagram. |
| 2 | February 10, 2016 | Added additional test setup photograph. |



Table of Contents

| | | |
|------------|--|-----------|
| 1.0 | Requirements Summary | 1 |
| 2.0 | Equipment Configuration | 2 |
| | Overview | 2 |
| | Test Site | 2 |
| | Description of Test Sample | 2 |
| | Equipment Configuration | 3 |
| | Support Equipment | 3 |
| | Ports and Cabling Information | 3 |
| | Mode of Operation | 4 |
| | Monitoring Method | 4 |
| | Modifications | 4 |
| | Modifications to EUT | 4 |
| | Modifications to Test Standard | 4 |
| | Disposition of EUT | 4 |
| 3.0 | Electromagnetic Compatibility Criteria for WB Devices | 5 |
| | Antenna Requirement | 5 |
| | § 15.207(a) Conducted Emissions Limits | 6 |
| | - 10 dB Bandwidth Requirements | 7 |
| | Operational Restrictions | 13 |
| | Radiated Emissions Above 960 MHz | 14 |
| | GPS emissions | 23 |
| | Peak Radiated Emissions | 26 |
| | Radiated emissions below 960 MHz | 28 |
| 4.0 | Test Equipment | 31 |
| 5.0 | Compliance Information | 32 |
| | Certification Information | 32 |

List of Tables

| | | |
|----------|---|----|
| Table 1. | Requirements Summary of EMC Part 15.250 Compliance Testing | 1 |
| Table 2. | Equipment Configuration | 3 |
| Table 3. | Support Equipment | 3 |
| Table 4. | Ports and Cabling Information | 3 |
| Table 5. | Conducted Limits for Intentional Radiators from FCC Part 15 § 15.207(a) | 6 |
| Table 6. | Limits for Radiated Emissions (RBW = 1MHz) | 14 |
| Table 7. | Limits for Radiated Emissions, RSS-220 | 14 |
| Table 8. | Limits for Radiated Emissions (RBW >= 1kHz) | 23 |
| Table 9. | Radiated Emissions Limits Calculated from FCC Part 15, § 15.209 (a) | 28 |

List of Plots

| | | |
|---------|---|---|
| Plot 1. | -10 dB Bandwidth, 1Mbs, 23°C, Nominal Voltage | 8 |
| Plot 2. | -10 dB Bandwidth, 1Mbs, 23°C, High Voltage | 8 |
| Plot 3. | -10 dB Bandwidth, 1Mbs, 23°C, low Voltage | 8 |



List of Terms and Abbreviations

| | |
|------------------------------|---|
| AC | Alternating Current |
| ACF | Antenna Correction Factor |
| Cal | Calibration |
| d | Measurement Distance |
| dB | Deci Bels |
| dBμV | Deci-Bels above one micro Volt |
| dBμV/m | Deci-Bels above one micro Volt per meter |
| DC | Direct Current |
| DCF | Distance Correction Factor |
| E | Electric Field |
| DSL | Digital Subscriber Line |
| ESD | Electrostatic Discharge |
| EUT | Equipment Under Test |
| f | Frequency |
| FCC | Federal Communications Commission |
| H | Magnetic Field |
| GHz | Giga Hertz |
| Hz | Hertz |
| ICES | Interference-Causing Equipment Standard |
| kHz | kilohertz |
| kPa | kilopascal |
| kV | kilo Volt |
| LISN | Line Impedance Stabilization Network |
| MHz | MegaHertz |
| μH | micro Henry |
| μF | micro Farad |
| μs | micro seconds |
| RF | Radio Frequency |
| RMS | Root-Mean-Square |
| V/m | Volts per meter |
| WB | Wideband |



1.0 Requirements Summary

The following tests were performed on a sample of the equipment for the purpose of demonstrating compliance with Part 15, Subpart C, §15.250, in accordance with Zebra Technologies Corporation Purchase Order Number 111124989.

| FCC Reference | IC Reference | Description | Compliance |
|--|------------------|---|---|
| Title 47 of the CFR, Part 15, Subpart C, §15.209(a) | RSS-220 5.1(b) | Antenna Requirements | Compliant |
| Title 47 of the CFR, Part 15, Subpart C, §15.207(a) | RSS-220 5.2.1(b) | Electromagnetic Compatibility - Conducted Emissions for Intentional Radiators | Not Applicable – The EUT is battery powered. |
| Title 47 of the CFR, Part 15, Subpart C, §15.250(a)(b) | RSS-220 5.1(a) | -10 dB Bandwidth | Compliant |
| Title 47 of the CFR, Part 15, Subpart C, §15.250(c) | RSS-GEN | Operational Restrictions | Applicant has been advised of these requirements. |
| Title 47 of the CFR, Part 15, Subpart C, §15.250(d)(1) | RSS-220 5.2.1(d) | Radiated emissions above 960 MHz (RMS Avg.) | Compliant |
| Title 47 of the CFR, Part 15, Subpart C, §15.250(d)(2) | RSS-220 5.2.1(e) | GPS emissions | Compliant |
| Title 47 of the CFR, Part 15, Subpart C, §15.250(d)(3) | RSS-220 5.2.1(g) | Peak emissions | Compliant |
| Title 47 of the CFR, Part 15, Subpart C, §15.250(d)(4) | RSS-220 5.2.1(c) | Radiated emissions below 960 MHz | Compliant |

Table 1. Requirements Summary of EMC Part 15.250 Compliance Testing



2. Equipment Configuration

2.1 Overview

An EMC evaluation to determine compliance of the Zebra Technologies Corporation radio module, UWX100 to be installed inside the host unit of Zebra Technologies Corp. with the requirements of Part 15, Subpart C, §15.250 and Industry Canada RSS-220 was performed. The UWX100 to be installed inside the host unit of Zebra Technologies Corp. (model UWT2100) has demonstrated compliance with all the stipulated standards referenced above. All references are to the most current version of Title 47 of the Code of Federal Regulations in effect. In accordance with §2.1033, the following data is presented in support of the Certification of the Zebra Technologies Corporation UWX100. Zebra Technologies Corporation should retain a copy of this document which should be kept on file for at least two years after the manufacturing of the UWX100 has been permanently discontinued.

| | | |
|---------------------------------|---|--------------|
| Type of Submission/Rule: | Part 15.250 for WB Devices | |
| Model(s) Tested: | UWX100 | |
| EUT Specifications: | FCC ID: | XWX-UWX100 |
| | IC: | 8701A-UWX100 |
| | Equipment Code: | WBT |
| Analysis: | The results obtained relate only to the item(s) tested. | |
| Evaluated by: | Djed Mouada | |
| Report Date(s): | February 10, 2016 | |

2.2 Test Site

All testing was performed at MET Laboratories, Inc., 914 W. Patapsco Avenue, Baltimore, Maryland 21230. All equipment used in making physical determinations is accurate and bears recent traceability to the National Institute of Standards and Technology.

Radiated Emissions measurements were performed inside of a semi-anechoic chamber. In accordance with §2.948(a)(3), a complete site description is contained at MET Laboratories.

2.3 Description of Test Sample

The Zebra Technologies Corporation UWX100, Equipment Under Test (EUT), is a transmitting module to be used with an external controller. It is possible to connect several UWX100 modules to the same controller in order to achieve synchronized transmissions and avoid signal blockage by the human body. The UWX100 modules with their controller are intended to be affixed to clothing on workers or athletes, typically with one UWX100 on the front and one on the back of the person.

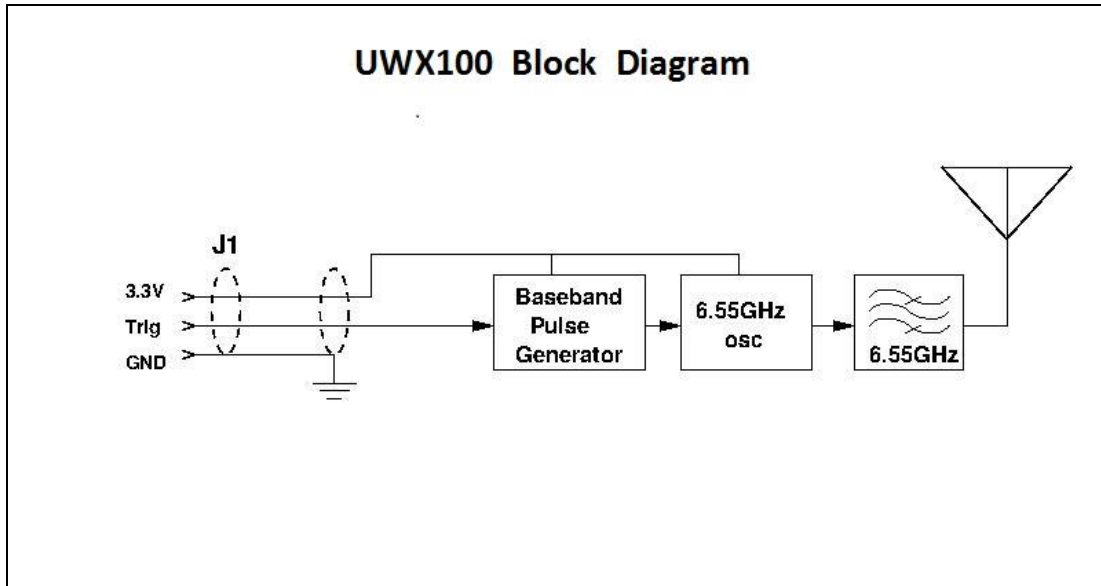

Figure 1. Block Diagram of UWX100

2.4 Equipment Configuration

All equipment incorporated as part of the EUT is included in the following list.

| Name / Description | Model Number | Serial Number |
|--------------------|--------------|---------------|
| Dart transmitter | UWX100 | -- |

Table 2. Equipment Configuration

2.4 Support Equipment

All equipment incorporated as part of the EUT is included in the following list.

| Name / Description | Manufacturer | Model Number |
|----------------------------------|--------------|--------------|
| Dart controller | Zebra | -- |
| Dart Wand | Zebra | WND-3100 |
| PC | -- | -- |
| Dart Wand Tag interface software | -- | -- |

Table 3. Support Equipment

2.4 Ports and Cabling Information

| Ref. ID | Port name on EUT | Cable Description or reason for no cable | Qty | Length as tested (m) | Max Length (m) | Shielded? (Y/N) | Termination Box ID & Port Name |
|---------|------------------|--|-----|----------------------|----------------|-----------------|--------------------------------|
| 1 | J1 | Power/trigger | 1 | 0.203 | 0.305 | Yes | J1 or J2 |

Table 4. Ports and Cabling Information



2.7 Mode of Operation

Through the associated controller, the UWX100 is fed power and trigger signals to cause the emission of brief packet bursts of RF pulses corresponding to the transmitted data. The controller limits the length of the packets, as well as the data rates. Data rates of 1Mbps and 2Mbps are anticipated. Emitted pulses are set to a duration of approximately 2nsec by the UWX100, and packet lengths are constrained to 169 pulses at 1Mbps and 95 pulses at 2Mbps. Packet rates are determined by the controller and are limited to 200 packets/sec as a maximum. In each case, packets are loaded with the maximum possible number of "1"s in the data stream.

2.8 Monitoring Method

Once the UWX100 starts transmission, there is no additional configuration needed. The transmission is detectable with a sensor/receiver which is a part of the Dart system. The Dart system detects the transmission. The information is monitored by using a PC connected to the Dart system. A USB-based Dart receiver will be used to activate the device, select its operating mode, and monitor its output.

2.9 Modifications

2.9.1 Modifications to EUT

No modifications were made to the EUT.

2.9.2 Modifications to Test Standard

No modifications were made to the test standard.

2.10 Disposition of EUT

The test sample including all support equipment submitted to the Electro-Magnetic Compatibility Lab for testing was returned to Zebra Technologies Corporation upon completion of testing.



3. Electromagnetic Compatibility Criteria for WB Devices

3.1 Antenna Requirement

Test Requirement: § 15.203: The structure and application of the EUT were analyzed to determine compliance with Section 15.203 of the Rules. Section 15.203 states that the subject device must meet at least one of the following criteria:

- a.) Antenna must be permanently attached to the unit.
- b.) Antenna must use a unique type of connector to attach to the EUT.
- c.) Unit must be professionally installed. Installer shall be responsible for verifying that the correct antenna is employed with the unit.

Test Results: The EUT complied with the requirement(s) of this section. The EUT has an integral antenna.

Test Engineer: Djed Mouada

Test Date: 09/18/15



3.2 § 15.207(a) Conducted Emissions Limits

Test Requirement(s): § 15.207 (a): For an intentional radiator that is designed to be connected to the public utility (AC) power line, the radio frequency voltage that is conducted back onto the AC power line on any frequency or frequencies, within the band 150 kHz to 30MHz, shall not exceed the limits in the following table, as measured using a 50 μ H/50 Σ line impedance stabilization network (LISN). Compliance with the provisions of this paragraph shall be based on the measurement of the radio frequency voltage between each power line and ground at the power terminal. The lower limit applies at the boundary between the frequency ranges.

| Frequency range (MHz) | § 15.207(a), Conducted Limit (dB μ V) | |
|-----------------------|---|---------|
| | Quasi-Peak | Average |
| * 0.15- 0.45 | 66 - 56 | 56 - 46 |
| 0.45 - 0.5 | 56 | 46 |
| 0.5 - 30 | 60 | 50 |

Table 5. Conducted Limits for Intentional Radiators from FCC Part 15 § 15.207(a)

Test Results: The EUT was not applicable with this requirement. The EUT is battery operated.



3.3 -10 dB Bandwidth Requirements

Test Requirements: § 15.250(a)(b): The -10 dB bandwidth of a device operating under the provisions of this section must be contained within the 5925 and 7250 MHz band under all conditions of operation including the effects from stepped frequency, frequency hopping or other modulation techniques that may be employed as well as the frequency stability of the transmitter over expected variations in temperature and supply voltage. The -10 dB bandwidth of the fundamental emission shall be at least 50 MHz.

Test Procedure: Emissions were measured using a horn antenna placed very close to the EUT. Due to the extremely wide nature of WB emissions, special considerations were taken to make the bandwidth measurements. The RBW was set to 1 MHz and the VBW to 3 MHz. Cable loss, pre-amp, and antenna correction factors have been programmed into spectrum analyzer.

Test Results The EUT complied with the requirement(s) of this section.

$$f_L = 6.24050\text{GHz}, f_H = 6.88457\text{ GHz}$$
$$\text{Therefore, -10 dB bandwidth} = f_H - f_L = 0.64407\text{ GHz}$$

Test Engineer: Djed Mouada

Test Dates: 09/09/15

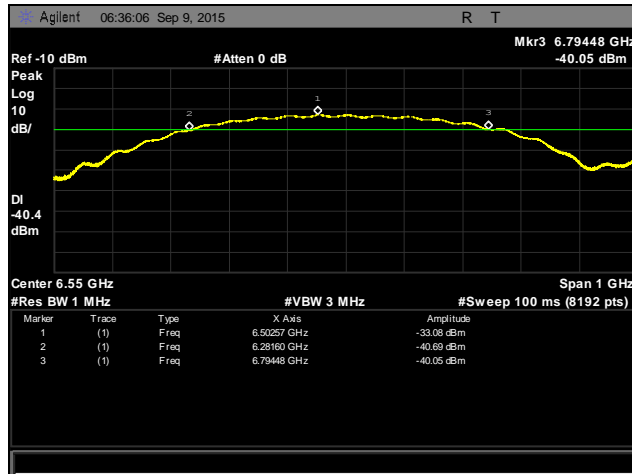

Plot 1. -10 dB Bandwidth, 1Mbs, 23°C, Nominal Voltage

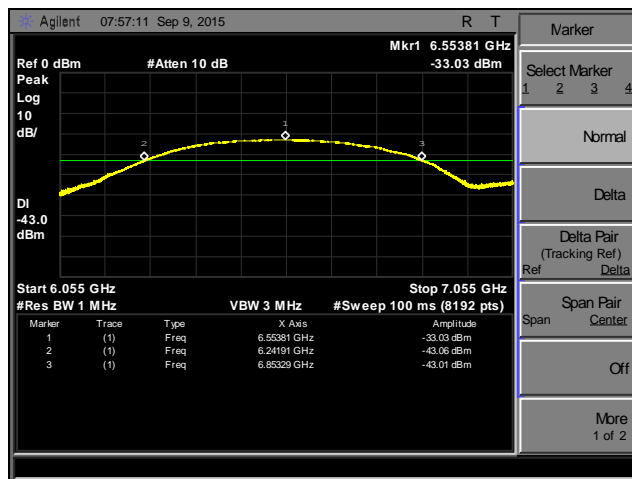

Plot 2. -10 dB Bandwidth, 1Mbs, 23°C, High Voltage

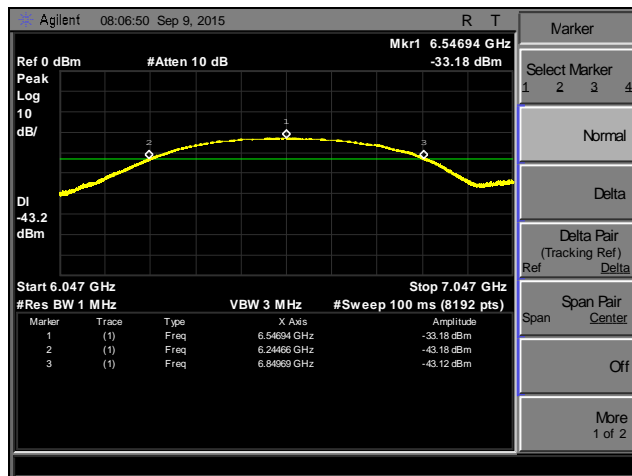

Plot 3. -10 dB Bandwidth, 1Mbs, 23°C, low Voltage

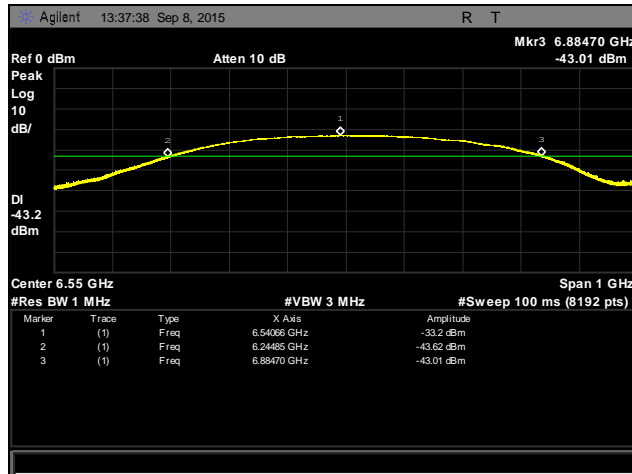

Plot 5. -10 dB Bandwidth, 1Mbs, -40°C, Nominal Voltage

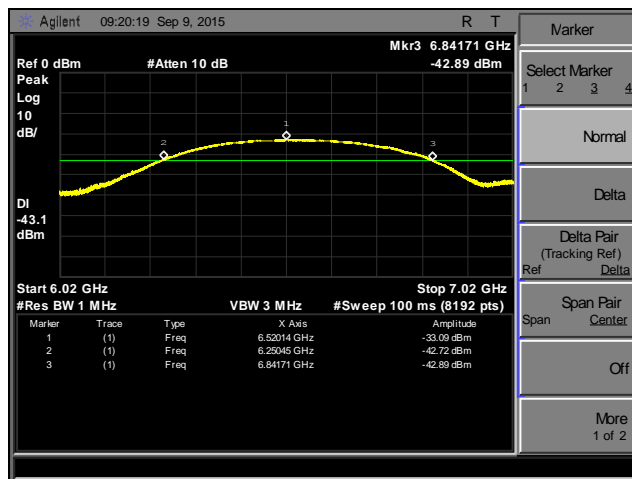

Plot 6. -10 dB Bandwidth, 1Mbs, 70°C, Nominal Voltage

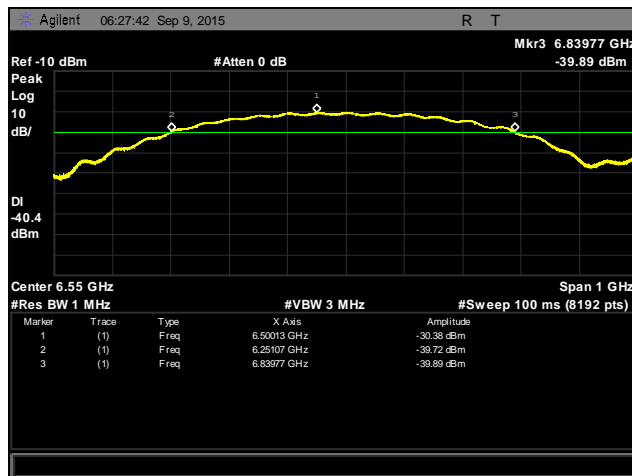

Plot 7. -10 dB Bandwidth, 2Mbs, 23°C, Nominal Voltage

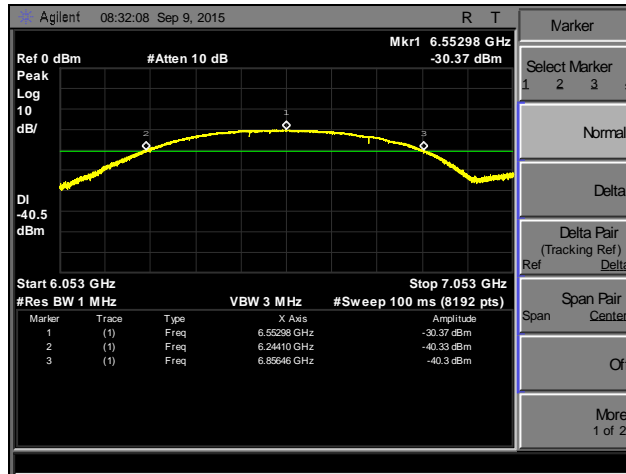

Plot 8. -10 dB Bandwidth, 2Mbps, 23°C, High Voltage

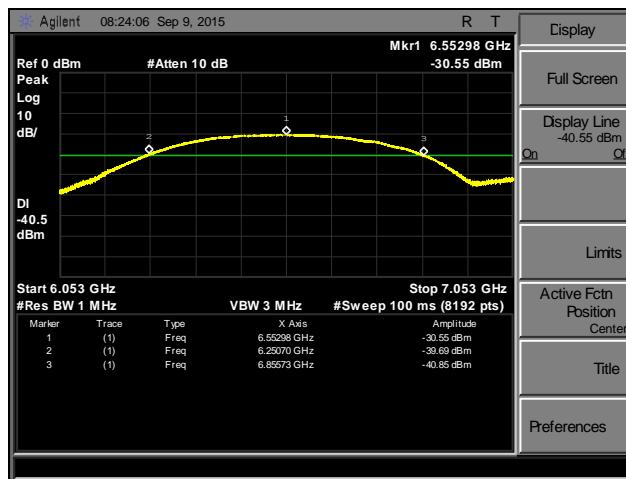

Plot 9. -10 dB Bandwidth, 2Mbps, 23°C, Low Voltage

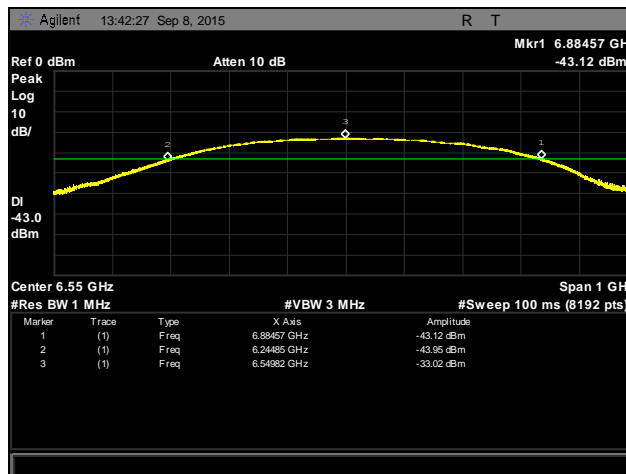

Plot 10. -10 dB Bandwidth, 2Mbps, -40°C, Nominal Voltage

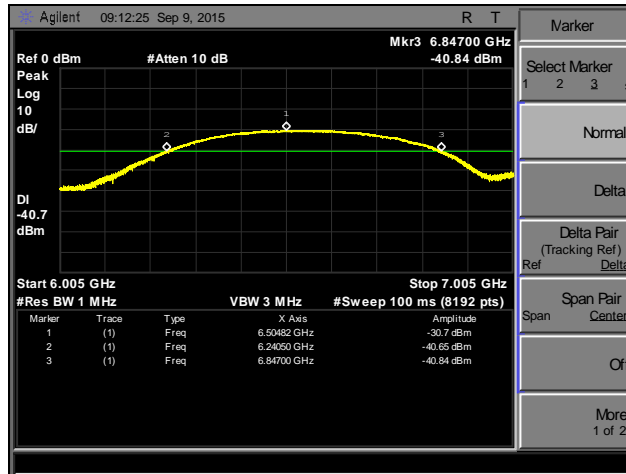

Plot 11. -10 dB Bandwidth, 2Mbps, 70°C , Nominal Voltage



Photograph 1. -10 dB Bandwidth, Test Setup



3.4 Operational Restrictions

Transmitter Requirements: §15.250(c): Technical Requirements for WB systems.

Operation under the provisions of this section is limited to WB transmitters employed in the following limitations;

- (1) Operation on board an aircraft or a satellite is prohibited.
- (2) Devices operating under this section may not be employed for the operation of toys.
- (3) Except for operation onboard a ship or a terrestrial transportation vehicle, the use of a fixed outdoor infrastructure is prohibited. A fixed infrastructure includes antennas mounted on outdoor structures, e.g., antennas mounted on the outside of a building or on a telephone pole.

Test Results: The client was notified of these requirements.

Test Engineer: Djed Mouada

Test Dates: 09/09/15

3.5 Radiated Emissions Above 960 MHz RMS Average

Test Requirements: § 15.250 (d)(1): Emissions from a transmitter operating under this section shall not exceed the following equivalent isotropically radiated power (EIRP) density levels:

Radiated Emissions above 960 MHz from a device operating under this section shall not exceed the average limits of Table 6 when measured using a RBW of 1 MHz.

| Frequency in MHz | EIRP in dBm |
|------------------|-------------|
| 960 - 1610 | -75.3 |
| 1610 - 1990 | -63.3 |
| 1990 - 3100 | -61.3 |
| 3100 - 5925 | -51.3 |
| 5925-7250 | -41.3 |
| 7250-10600 | -51.3 |
| Above 10600 | -61.3 |

Table 6. Limits for Radiated Emissions (RBW = 1MHz)

| Indoor Communication, Measurement, Location Sensing and Tracking Devices | |
|--|---|
| Frequency | E.i.r.p. in a Resolution Bandwidth of 1 MHz |
| 960-1 610 MHz | -75.3 dBm |
| 1.61-4.75 GHz | -70.0 dBm |
| 4.75-10.6 GHz | -41.3 dBm |
| Above 10.6 GHz | -51.3 dBm |

Table 7. Limits for Radiated Emissions, RSS-220

Test Procedure: The EUT was placed on a pedestal inside a semi-anechoic chamber. A horn antenna with a pre-amp was placed at various distances away from the EUT and measurements made. Measurements were performed with the EUT oriented in 3 orthogonal axis and rotated 360 degrees to determine worst case orientation for maximum emissions.

Cable loss, pre-amp, distance correction, and antenna correction factors have been programmed into the spectrum analyzer. Only noise floor was observed above 18GHz.



Frequency determining parameters: The highest frequency employed in §15.33 to determine the frequency range over which radiated emissions are made were based on the center frequency, f_c , unless a higher frequency was generated within the WB device. For measuring emission levels, the spectrum were investigated from the lowest frequency generated in the WB, without going below 9 kHz, up to the frequency range shown in Section 15.33(a) of the CFR 47 or up to $f_c + 3/(\text{pulse width in seconds})$, whichever was higher. There is no requirement to measure emissions beyond 40 GHz provided f_c was less than 10 GHz; beyond 100 GHz if f_c was at or above 10 GHz and below 30 GHz; or beyond 200 GHz if f_c was at or above 30 GHz.

Test Results: The EUT complied with the requirement(s) of this section. Plots are provided for emissions between 960 – 18000 MHz. The plots display the EIRP measurement against the appropriate limit line. Emissions were also investigated from 18 GHz to 40 GHz. Only noise floor was detected at these frequencies.

Test Engineer: Djed Mouada

Test Dates: 09/18/15

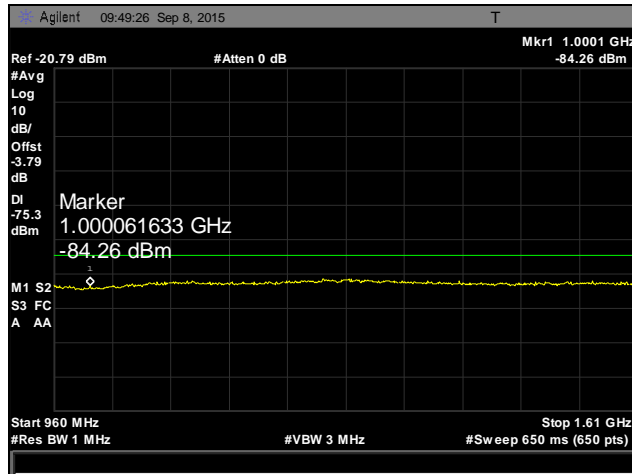

Plot 12. Radiated Emissions Above 960 MHz, 960 MHz – 1610 MHz, 1MBps

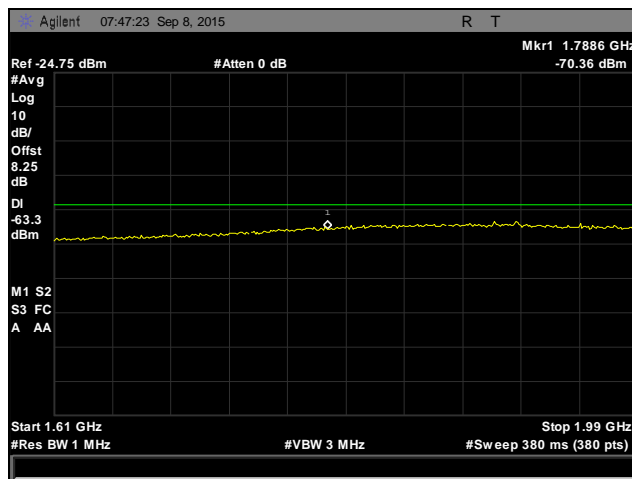

Plot 13. Radiated Emissions Above 960 MHz, 1610 MHz – 1990 MHz, 1MBps

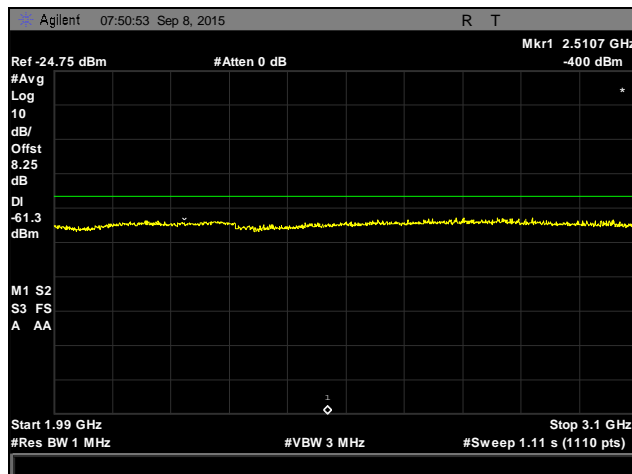

Plot 14. Radiated Emissions Above 960 MHz, 1990 MHz – 3100 MHz, 1MBps

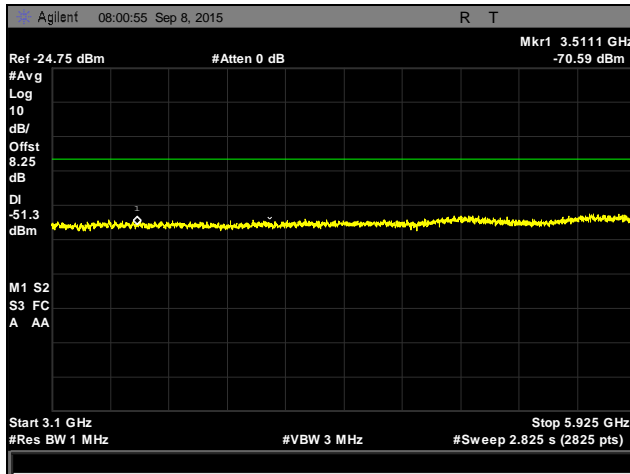

Plot 15. Radiated Emissions Above 960 MHz, 3100MHz – 5925 MHz, 1MBps

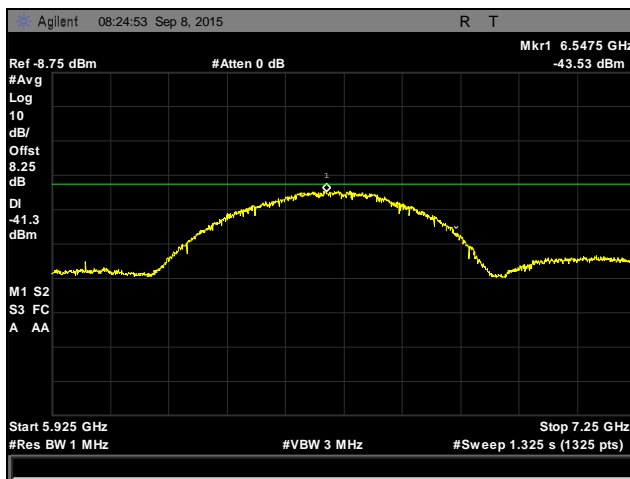

Plot 16. Radiated Emissions Above 960 MHz, 5925 MHz – 7250 MHz, 1MBps

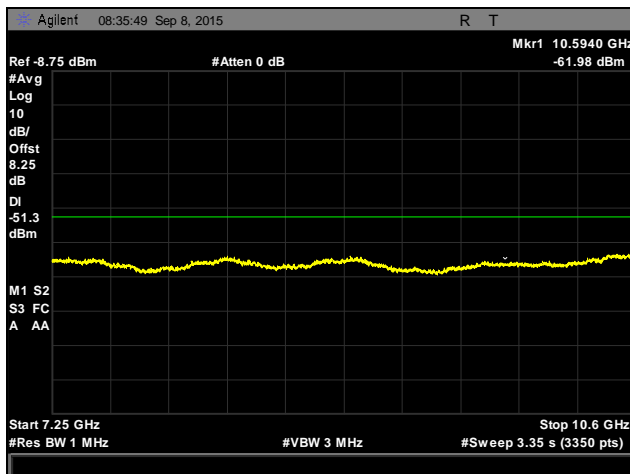

Plot 17. Radiated Emissions Above 960 MHz, 7250 MHz – 10600 MHz, 1MBps

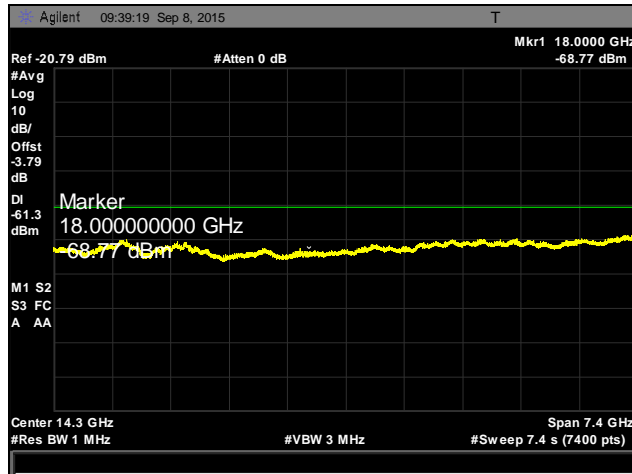

Plot 18. Radiated Emissions Above 960 MHz, 10600 MHz – 18000 MHz, 1MBps

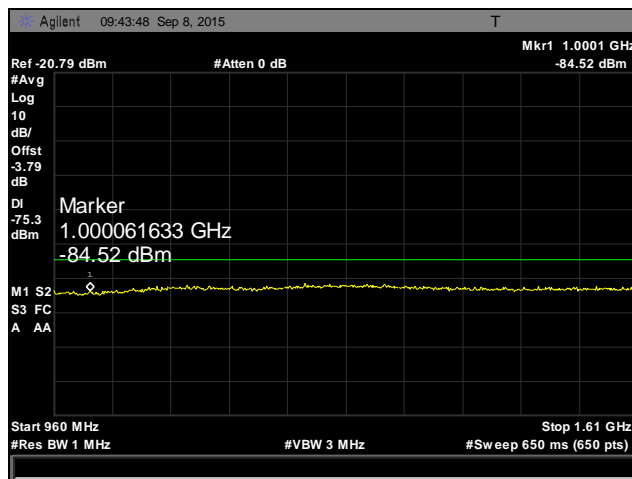

Plot 19. Radiated Emissions Above 960 MHz, 960 MHz – 1610 MHz, 2MBps

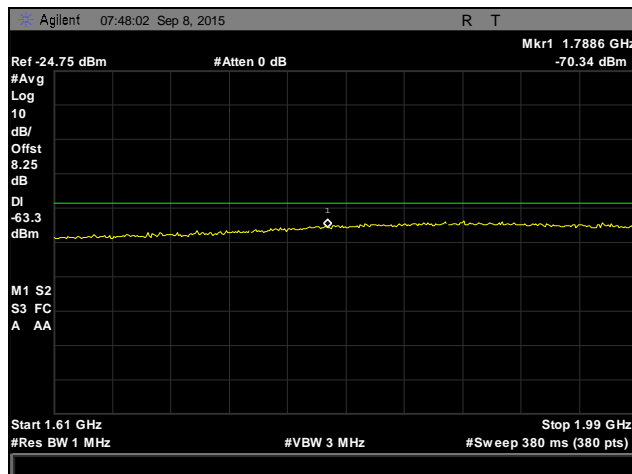

Plot 20. Radiated Emissions Above 960 MHz, 1610 MHz – 1990 MHz, 2MBps

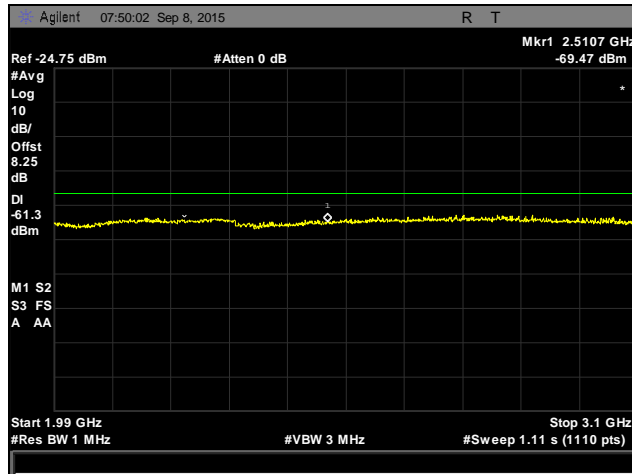

Plot 21. Radiated Emissions Above 960 MHz, 1990 MHz – 3100 MHz, 2MBps

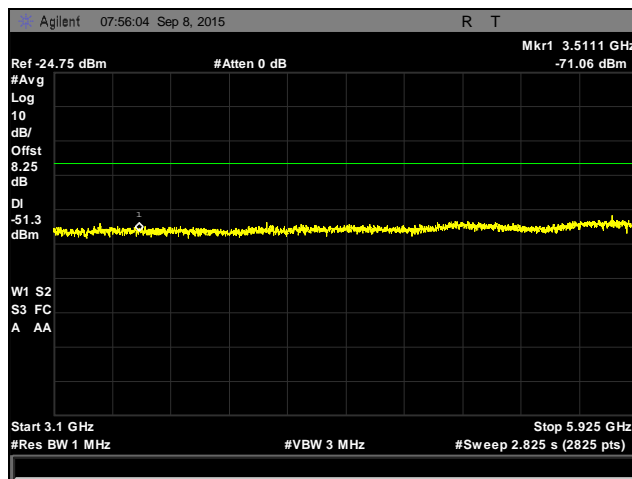

Plot 22. Radiated Emissions Above 960 MHz, 3100 MHz – 5925 MHz, 2MBps

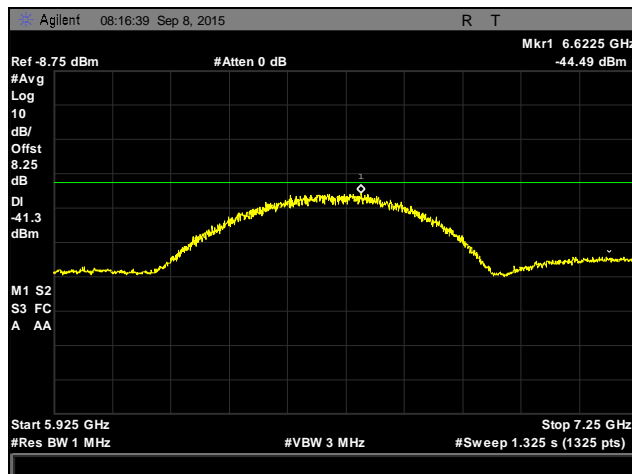

Plot 23. Radiated Emissions Above 960 MHz, 5925 MHz – 7250 MHz, 2MBps

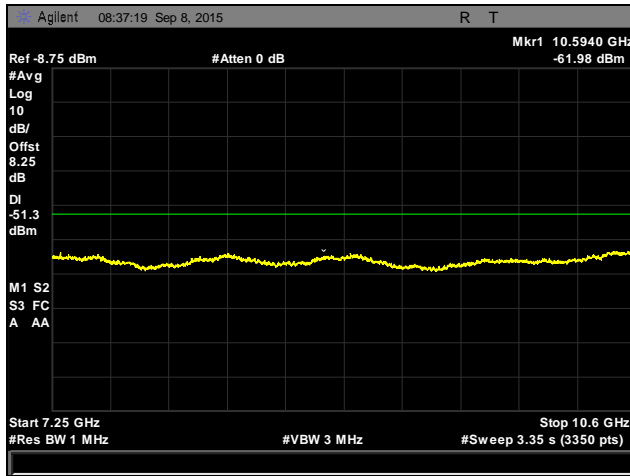

Plot 24. Radiated Emissions Above 960 MHz, 7250 MHz – 10600 MHz, 2MBps

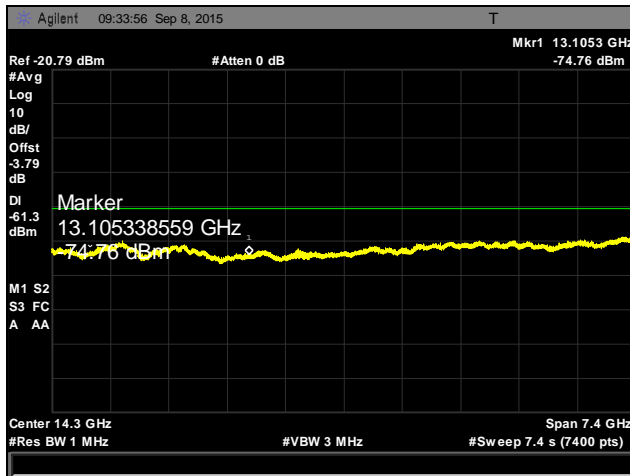

Plot 25. Radiated Emissions Above 960 MHz, 10600 MHz – 18000 MHz, 2MBps

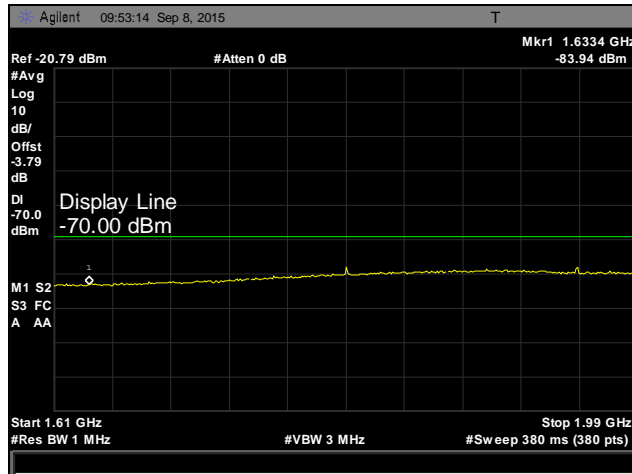

Plot 26. Radiated Emissions Above 960 MHz, 1610 MHz – 1900 MHz, 1MBps, IC Limit

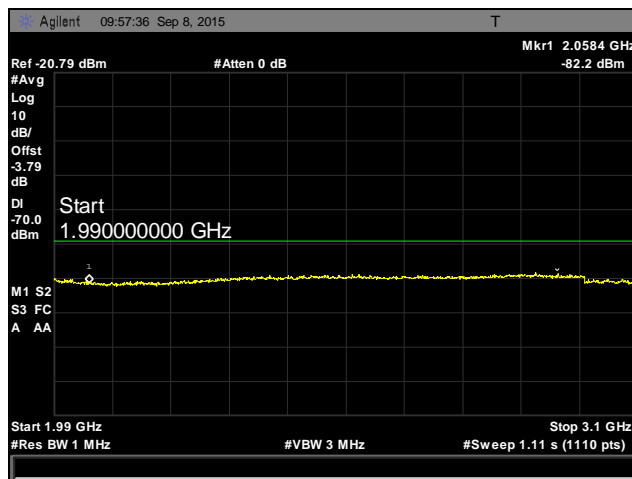

Plot 27. Radiated Emissions Above 960 MHz, 1990 MHz – 3100 MHz, 1MBps, IC Limit

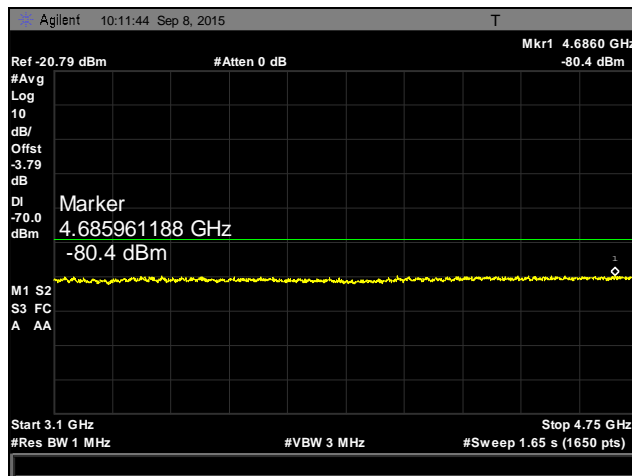

Plot 28. Radiated Emissions Above 960 MHz, 3100 MHz – 4750 MHz, 1MBps, IC Limit

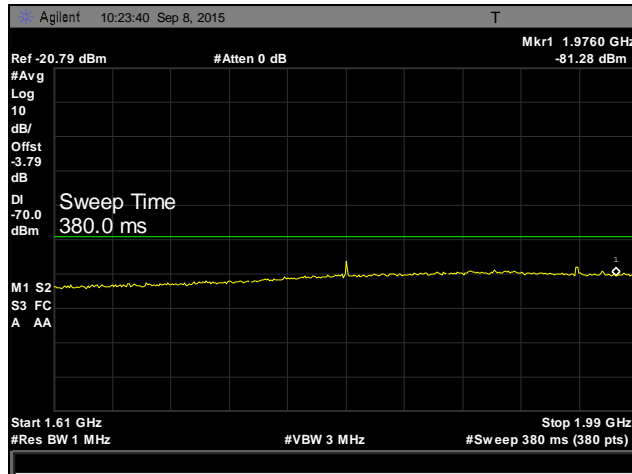

Plot 29. Radiated Emissions Above 960 MHz, 1610 MHz – 1900 MHz, 2Mbps, IC Limit

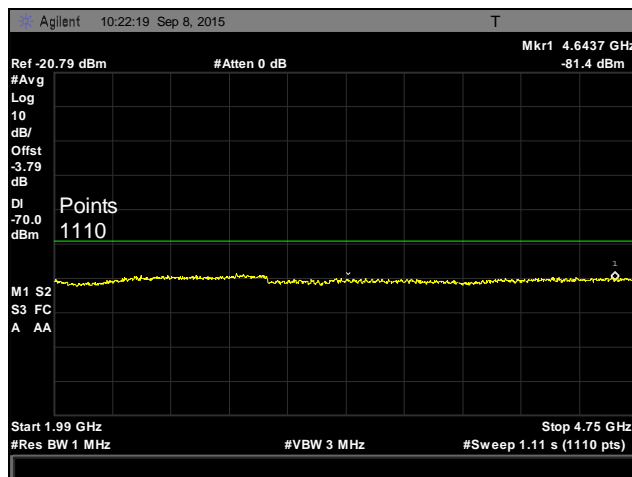

Plot 30. Radiated Emissions Above 960 MHz, 1990 MHz – 3100 MHz, 2Mbps, IC Limit

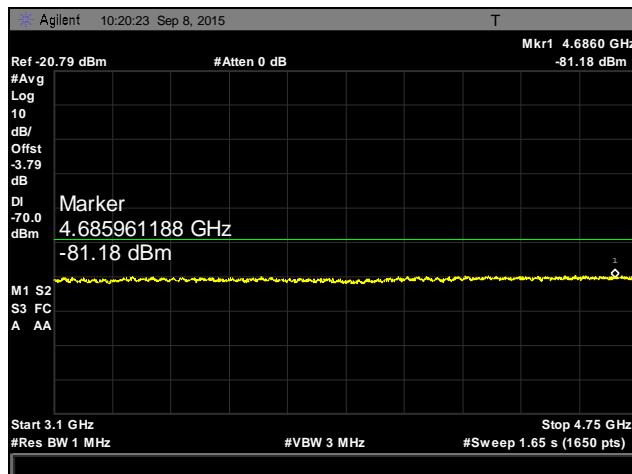

Plot 31. Radiated Emissions Above 960 MHz, 3100 MHz – 4750 MHz, 2Mbps, IC Limit



3.6 GPS emissions

Test Requirements: §15.250(d)(2): In addition to the radiated emission limits specified in the table in paragraph (d)(1) of this section, transmitters operating under the provisions of this section shall not exceed the following RMS average limits when measured using a resolution bandwidth of no less than 1 kHz:

| Frequency in MHz | EIRP in dBm |
|------------------|-------------|
| 1164 - 1240 | -85.3 |
| 1559 - 1610 | -85.3 |

Table 8. Limits for Radiated Emissions (RBW \geq 1kHz)

Test Results: The EUT was compliant with the requirement(s) of this section.

Test Engineer: Djed Mouada

Test Date: 09/18/15

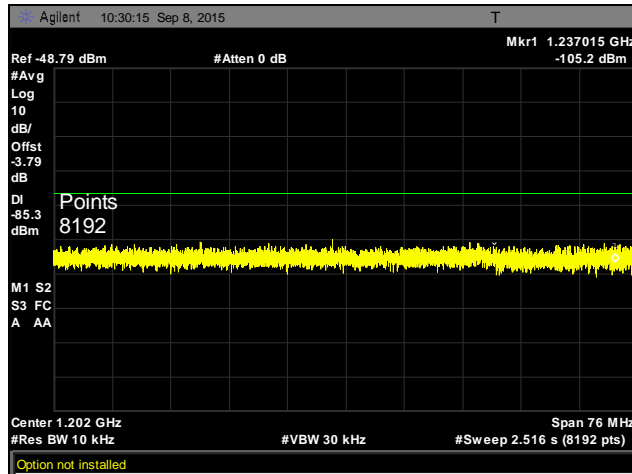

Plot 32. GPS Bands, 1164 MHz – 1240 MHz, 1MBps

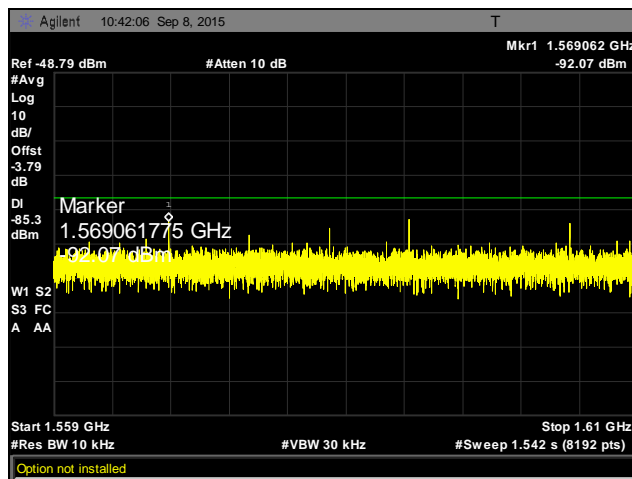

Plot 33. GPS Bands, 1559 MHz – 1610 MHz, 1MBps

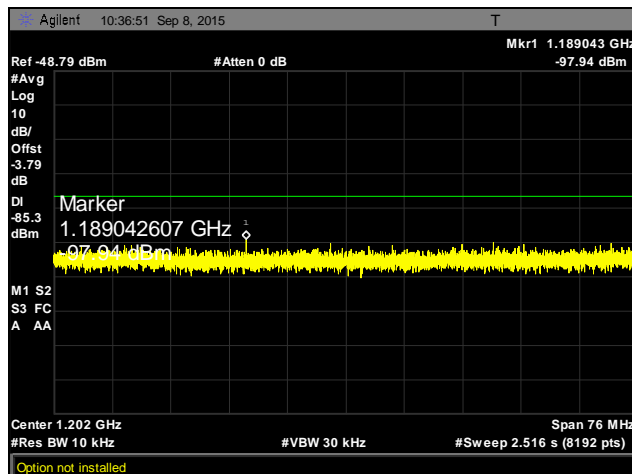

Plot 34. GPS Bands, 1164 MHz – 1240 MHz, 2MBps

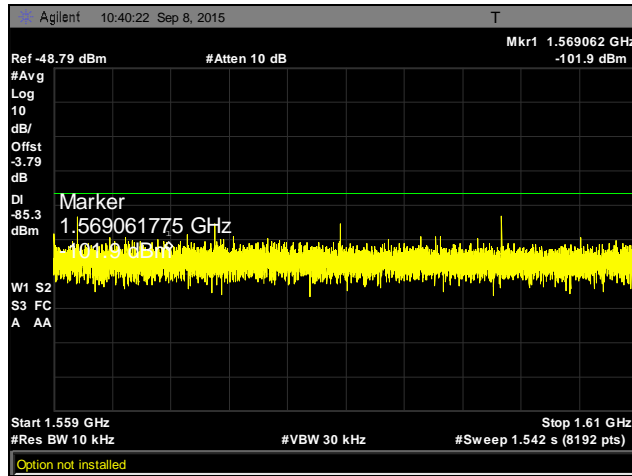

Plot 35. GPS Bands, 1559 MHz – 1610 MHz, 2MBps



3.7 Peak Radiated Emissions Requirements

Test Requirements: §15.250(d) (3): There is a limit on the peak level of the emissions contained within a 50 MHz bandwidth centered on the frequency at which the highest radiated emission occurs and this 50 MHz bandwidth must be contained within the 5925–7250 MHz band. The peak EIRP limit is $20 \log (RBW/50)$ dBm where RBW is the resolution bandwidth in megahertz that is employed by the measurement instrument. RBW shall not be lower than 1 MHz or greater than 50 MHz. The video bandwidth of the measurement instrument shall not be less than RBW. If RBW is greater than 3 MHz, the application for certification filed with the Commission shall contain a detailed description of the test procedure, calibration of the test setup, and the instrumentation employed in the testing.

Calculation of Limit: The Offset was added to reflect measurements conducted at 2m.

Test Results: The EUT was found to comply with the requirements of §15.250(d)(3). Measured with 3MHz RBW. $\text{Limit} = 20 \log(3\text{MHz}/50\text{MHz}) = -24.43\text{dBm EIRP}$.

Test Engineer: Djed Mouada

Test Date: 09/18/15

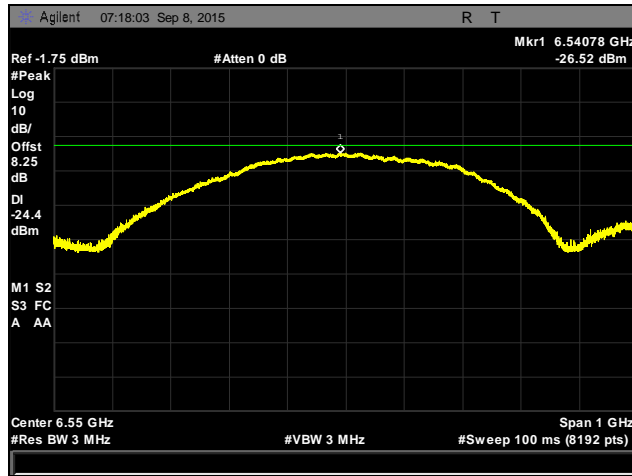

Plot 36. Peak Emissions, 1MBps

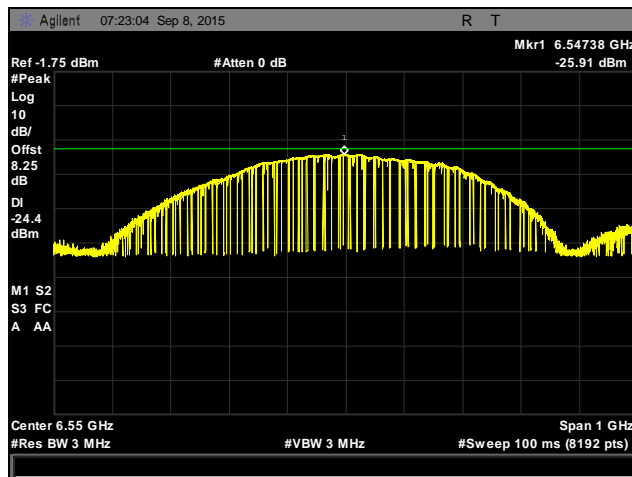

Plot 37. Peak Emissions, 2MBps



3.8 15.250(d)(4) Radiated emissions below 960 MHz

Test Requirements: § 15.250 (d)(4): Radiated emissions at or below 960 MHz shall not exceed the emission levels in § 15.209.

§ 15.209 (a) Except as provided elsewhere in this subpart, the emissions from an intentional radiator shall not exceed the field strength levels specified in Table 9.

| Frequency (MHz) | §15.209(a), Radiated Emission Limits (dB:V) @ 3m |
|-----------------|--|
| 30 - 88 | 40.00* |
| 88 - 216 | 43.50* |
| 216 - 960 | 46.00* |
| Above 960 | 54.00 |

* -- Except perimeter protection systems operating under paragraph (g), fundamental emissions from intentional radiators operating under this Section shall not be located in the frequency bands 54-72 MHz, 76-88 MHz, 174-216 MHz or 470-806 MHz. However, operation within these frequency bands is permitted under other sections of this Subpart.

Table 9. Radiated Emissions Limits Calculated from FCC Part 15, § 15.209 (a)

Test Procedure: The EUT was placed on a 0.8m pedestal inside a semi-anechoic chamber. A measurement antenna was placed 3 m away from the EUT. The EUT was rotated about all three orthogonal axis while a pre-scan was performed. The antenna was varied between 1 m and 4 m, in both horizontal and vertical polarities.

Test Results: The EUT complied with the requirement(s) of this section.

Test Engineer: Djed Mouada

Test Date: 09/18/15

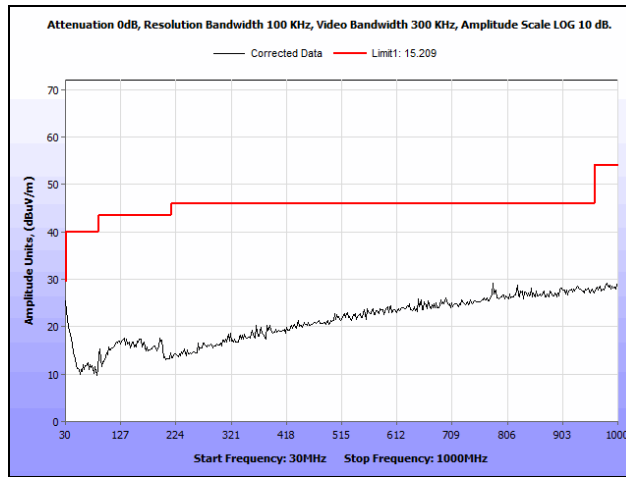

Plot 38. Radiated Emissions Below 960 MHz, 30 MHz – 1 GHz, 1MBps

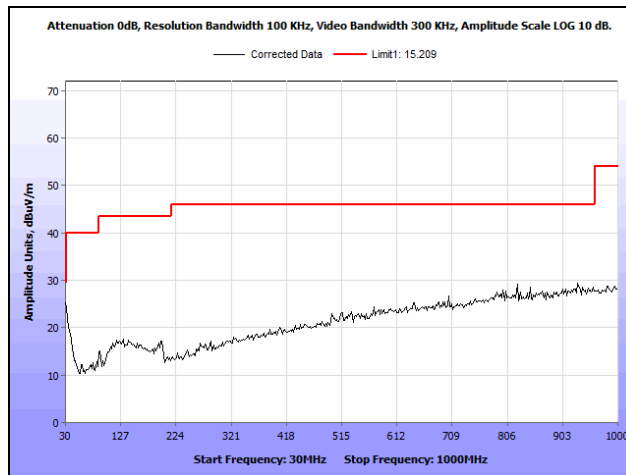

Plot 39. Radiated Emissions Below 960 MHz, 30 MHz – 1 GHz, 2MBps



Photograph 2. Radiated Emissions, Test Setup



4.0 Test Equipment

Calibrated test equipment utilized during testing was maintained in a current state of calibration per the requirements of ISO/IEC 17025:2005.

| MET ASSET # | EQUIPMENT | MANUFACTURER | MODEL | LAST CAL DATE | CAL DUE DATE |
|-------------|---------------------------------|----------------------|-----------------------|---------------|--------------|
| 1T4300A | SEMI-ANECHOIC CHAMBER # 1 (FCC) | EMC TEST SYSTEMS | NONE | 1/31/2015 | 1/31/2017 |
| 1T4751 | ANTENNA - BILOG | SUNOL SCIENCES | JB6 | 7/29/2014 | 1/29/2016 |
| 1T4771 | PSA SPECTRUM ANALYZER | AGILENT TECHNOLOGIES | E4446A | 11/25/2014 | 5/25/2016 |
| 1T4442 | PRE-AMPLIFIER, MICROWAVE | MITEQ | AFS42-01001800-30-10P | SEE NOTE | |
| 1T4505 | TEMPERATURE CHAMBER | TEST EQUITY | 115 | 2/11/2015 | 2/11/2016 |
| 1T4483 | ANTENNA; HORN | ETS-LINDGREN | 3117 | 2/28/2014 | 9/28/2015 |

Note: Functionally verified test equipment is verified using calibrated instrumentation at the time of testing.



5.0 Compliance Information

5.1 Certification Information

The following is extracted from Title 47 of the Code of Federal Regulations, Part 2, Subpart I — Marketing of Radio frequency devices:

§ 2.801 Radio-frequency device defined.

As used in this part, a radio-frequency device is any device which in its operation is capable of Emitting radio-frequency energy by radiation, conduction, or other means. Radio- frequency devices include, but are not limited to:

- (a) The various types of radio communication transmitting devices described throughout this chapter.
- (b) The incidental, unintentional and intentional radiators defined in Part 15 of this chapter.*
- (c) The industrial, scientific, and medical equipment described in Part 18 of this chapter.
- (d) Any part or component thereof which in use emits radio-frequency energy by radiation, conduction, or other means.

§ 2.803 Marketing of radio frequency devices prior to equipment authorization.

- (a) Except as provided elsewhere in this chapter, no person shall sell or lease, or offer for sale or lease (including advertising for sale or lease), or import, ship or distribute for the purpose of selling or leasing or offering for sale or lease, any radio frequency device unless:
 - (1) In the case of a device subject to certification, such device has been authorized by the Commission in accordance with the rules in this chapter and is properly identified and labeled as required by §2.925 and other relevant sections in this chapter; or
 - (2) In the case of a device that is not required to have a grant of equipment authorization issued by the Commission, but which must comply with the specified technical standards prior to use, such device also complies with all applicable administrative (including verification of the equipment or authorization under a Declaration of Conformity, where required), technical, labeling and identification requirements specified in this chapter.
- (d) Notwithstanding the provisions of paragraph (a) of this section, the offer for sale solely to business, commercial, industrial, scientific or medical users (but not an offer for sale to other parties or to end users located in a residential environment) of a radio frequency device that is in the conceptual, developmental, design or pre-production stage is permitted prior to equipment authorization or, for devices not subject to the equipment authorization requirements, prior to a determination of compliance with the applicable technical requirements *provided* that the prospective buyer is advised in writing at the time of the offer for sale that the equipment is subject to the FCC rules and that the equipment will comply with the appropriate rules before delivery to the buyer or to centers of distribution.



- (e)(1) Notwithstanding the provisions of paragraph (a) of this section, prior to equipment authorization or determination of compliance with the applicable technical requirements any radio frequency device may be operated, but not marketed, for the following purposes and under the following conditions:
- (i) *Compliance testing;*
 - (ii) Demonstrations at a trade show provided the notice contained in paragraph (c) of this section is displayed in a conspicuous location on, or immediately adjacent to, the device;
 - (iii) Demonstrations at an exhibition conducted at a business, commercial, industrial, scientific or medical location, but excluding locations in a residential environment, provided the notice contained in paragraphs (c) or (d) of this section, as appropriate, is displayed in a conspicuous location on, or immediately adjacent to, the device;
 - (iv) Evaluation of product performance and determination of customer acceptability, provided such operation takes place at the manufacturer's facilities during developmental, design or pre-production states; or
 - (v) Evaluation of product performance and determination of customer acceptability where customer acceptability of a radio frequency device cannot be determined at the manufacturer's facilities because of size or unique capability of the device, provided the device is operated at a business, commercial, industrial, scientific or medical user's site, but not at a residential site, during the development, design or pre-production stages.
- (e)(2) For the purpose of paragraphs (e)(1)(iv) and (e)(1)(v) of this section, the term *manufacturer's facilities* includes the facilities of the party responsible for compliance with the regulations and the manufacturer's premises, as well as the facilities of other entities working under the authorization of the responsible party in connection with the development and manufacture, but not the marketing, of the equipment.
- (f) For radio frequency devices subject to verification and sold solely to business, commercial, industrial, scientific and medical users (excluding products sold to other parties or for operation in a residential environment), parties responsible for verification of the devices shall have the option of ensuring compliance with the applicable technical specifications of this chapter at each end user's location after installation, provided that the purchase or lease agreement includes a proviso that such a determination of compliance be made and is the responsibility of the party responsible for verification of the equipment.



The following is extracted from Title 47 of the Code of Federal Regulations, Part 2, and Subpart J— Equipment Authorization Procedures:

§ 2.901 Basis and Purpose

- (a) In order to carry out its responsibilities under the Communications Act and the various treaties and international regulations, and in order to promote efficient use of the radio spectrum, the Commission has developed technical standards for radio frequency equipment and parts or components thereof. The technical standards applicable to individual types of equipment are found in that part of the rules governing the service wherein the equipment is to be operated.¹ *In addition to the technical standards provided, the rules governing the service may require that such equipment be verified by the manufacturer or importer*, be authorized under a Declaration of Conformity, or receive an equipment authorization from the Commission by one of the following procedures: certification or registration.
- (b) The following sections describe the verification procedure, the procedure for a Declaration of Conformity, and the procedures to be followed in obtaining certification from the Commission and the conditions attendant to such a grant.

§ 2.907 Certification

- (a) Certification is an equipment authorization issued by the Commission, based on representation and test data submitted by the applicant.
- (b) Certification attaches to all units subsequently marketed by the grantee which are identical (see Section 2.908) to the sample tested except for permissive changes or other variations authorized by the Commission pursuant to Section 2.1043.

¹ In this case, the equipment is subject to the rules of Part 15. More specifically, the equipment falls under Subpart B (of Part 15), which deals with unintentional radiators.



§ 2.948 Description of measurement facilities.

- (a) Each party making measurements of equipment that is subject to an equipment authorization under Part 15 or Part 18 of this chapter, regardless of whether the measurements are filed with the Commission or kept on file by the party responsible for compliance of equipment marketed within the U.S. or its possessions, shall compile a description of the measurement facilities employed.
 - (1) If the measured equipment is subject to the verification procedure, the description of the measurement facilities shall be retained by the party responsible for verification of the equipment.
 - (i) *If the equipment is verified through measurements performed by an independent laboratory, it is acceptable for the party responsible for verification of the equipment to rely upon the description of the measurement facilities retained by or placed on file with the Commission by that laboratory. In this situation, the party responsible for the verification of the equipment is not required to retain a duplicate copy of the description of the measurement facilities.*
 - (ii) If the equipment is verified based on measurements performed at the installation site of the equipment, no specific site calibration data is required. It is acceptable to retain the description of the measurement facilities at the site at which the measurements were performed.
 - (2) If the equipment is to be authorized by the Commission under the certification procedure, the description of the measurement facilities shall be filed with the Commission's Laboratory in Columbia, Maryland. The data describing the measurement facilities need only be filed once but must be updated as changes are made to the measurement facilities or as otherwise described in this section. At least every three years, the organization responsible for filing the data with the Commission shall certify that the data on file is current.