

August 19, 2019

Zebra Technologies Corporation
2940 N. 1st Street
San Jose, CA 95134

Dear Andrei Moldavanov,

Enclosed is the EMC test report for compliance testing of the Zebra Technologies Corporation, Dart Tag, UWT-1500 as tested to the requirements of Title 47 of the CFR, Ch. 1 (10-1-03 ed.), Part 15 Subpart C, §15.250.

Thank you for using the services of Eurofins MET Labs, Inc. If you have any questions regarding these results or if MET can be of further service to you, please feel free to contact me.

Sincerely yours,
EUROFINS MET LABS, INC.



Joel Huna
Documentation Department

Reference: (\\Zebra Technologies Corporation\EMC102664-FCC250 Rev. 1)

Certificates and reports shall not be reproduced except in full, without the written permission of Eurofins MET Labs, Inc. While use of the A2LA logo in this report reflects MET accreditation under these programs, the report must not be used by the client to claim product certification, approval, or endorsement by A2LA or any agency of the Federal Government. This letter of transmittal is not a part of the attached report.

DOC-EMC702 2/26/2004

Electromagnetic Compatibility Criteria Test Report

For the

**Zebra Technologies Corporation
Dart Tag, UWT-1500**

Tested under
the FCC Certification Rules
contained in
Title 47 of the CFR, Part 15.250 Subpart C
for Wideband Operation

MET Report: EMC102664-FCC250 Rev. 1

May 21, 2019

Prepared For:

**Zebra Technologies Corporation
2940 N. 1st Street
San Jose, CA 95134**

Prepared By:
Eurofins MET Labs, Inc.
914 West Patapsco Avenue,
Baltimore, MD 21230

Electromagnetic Compatibility Criteria Test Report

For the

Zebra Technologies Corporation
Dart Tag, UWT-1500

Tested under
the FCC Certification Rules
contained in
Title 47 of the CFR, Part 15.250 Subpart C
for Wideband Operation



Donald Salguero, Project Engineer
Electromagnetic Compatibility Lab



Joel Huna
Documentation Department

Engineering Statement: The measurements shown in this report were made in accordance with the procedures indicated, and the emissions from this equipment were found to be within the limits applicable. I assume full responsibility for the accuracy and completeness of these measurements, and for the qualifications of all persons taking them. It is further stated that upon the basis of the measurements made, the equipment tested is capable of operation in accordance with the requirements of Part 15.250 of the FCC Rules under normal use and maintenance.



Benjamin Taylor
Wireless Manager, Electromagnetic Compatibility Lab

Report Status Sheet

Revision	Report Date	Reason for Revision
∅	May 21, 2019	Initial Issue.
1	July 18, 2019	TCB Requested Updates

Table of Contents

1.0	Requirements Summary	1
2.0	Equipment Configuration	2
	Overview	2
	Test Site	2
	Description of Test Sample	2
	Equipment Configuration	3
	Support Equipment	3
	Ports and Cabling Information	4
	Mode of Operation	4
	Monitoring Method	4
	Modifications	4
	Modifications to EUT	4
	Modifications to Test Standard	4
	Disposition of EUT	4
3.0	Electromagnetic Compatibility Criteria for WB Devices	5
	Antenna Requirement	5
	- 10 dB Bandwidth Requirements	6
	Operational Restrictions	8
	Radiated Emissions Above 960 MHz	9
	GPS emissions	15
	Peak Radiated Emissions	17
	Radiated emissions below 960 MHz	19
4.0	Test Equipment	22
5.0	Compliance Information	23
	Certification Information	23

List of Tables

Table 1.	Requirements Summary of EMC Part 15.250 Compliance Testing	1
Table 2.	Equipment Configuration	3
Table 3.	Support Equipment	3
Table 4.	Limits for Radiated Emissions (RBW = 1MHz)	9
Table 5.	Radiated Emissions above 960MHz, Test Results	10
Table 6.	Limits for Radiated Emissions (RBW >= 1kHz)	15
Table 7.	Peak Radiated Emissions, Test Results	17
Table 8.	Radiated Emissions Limits Calculated from FCC Part 15, § 15.209 (a)	19

List of Plots

Plot 1.	-10 dB Bandwidth, 1 MBit	7
Plot 2.	-10 dB Bandwidth, 2 MBit	7

List of Terms and Abbreviations

AC	A lternating C urrent
ACF	A ntenna C orrection F actor
Cal	C alibration
d	M easurement D istance
dB	D eci B els
dBμV	D eci- B els above one m icro V olt
dBμV/m	D eci- B els above one m icro V olt p er m eter
DC	D irect C urrent
DCF	D istance C orrection F actor
E	E lectric F ield
DSL	D igital S ubscriber L ine
ESD	E lectrostatic D ischarge
EUT	E quipment U nder T est
f	F requency
FCC	F ederal C ommunications C ommission
H	M agnetic F ield
GHz	G iga H ertz
Hz	H ertz
ICES	I nterference- C ausing E quipment S tandard
kHz	k ilo h ertz
kPa	k ilo p ascal
kV	k ilo V olt
LISN	L ine I mpedance S tabilization N etwork
MHz	M ega H ertz
μH	m icro H enry
μF	m icro F arad
μs	m icro s econds
RF	R adio F requency
RMS	R oot- M ean- S quare
V/m	V olts per m eter
WB	W ide b and

1.0 Requirements Summary

The following tests were performed on a sample of the equipment for the purpose of demonstrating compliance with Part 15, Subpart C, §15.250, in accordance with Zebra Technologies Corporation Purchase Order Number 112024794.

FCC Reference	Description	Compliance
Title 47 of the CFR, Part 15, Subpart C, §15.209(a)	Antenna Requirements	Compliant
Title 47 of the CFR, Part 15, Subpart C, §15.207(a)	Electromagnetic Compatibility - Conducted Emissions for Intentional Radiators	Not Applicable
Title 47 of the CFR, Part 15, Subpart C, §15.250(a)(b)	-10 dB Bandwidth	Compliant
Title 47 of the CFR, Part 15, Subpart C, §15.250(c)	Operational Restrictions	Applicant has been advised of these requirements.
Title 47 of the CFR, Part 15, Subpart C, §15.250(d)(1)	Radiated emissions above 960 MHz (RMS Avg.)	Compliant
Title 47 of the CFR, Part 15, Subpart C, §15.250(d)(2)	GPS emissions	Compliant
Title 47 of the CFR, Part 15, Subpart C, §15.250(d)(3)	Peak emissions	Compliant
Title 47 of the CFR, Part 15, Subpart C, §15.250(d)(4)	Radiated emissions below 960 MHz	Compliant

Table 1. Requirements Summary of EMC Part 15.250 Compliance Testing

2. Equipment Configuration

2.1 Overview

An EMC evaluation to determine compliance of the Zebra Technologies Corporation radio module, Dart Tag, UWT-1500 to be installed inside the host unit of Zebra Technologies Corporation with the requirements of Part 15, Subpart C, §15.250 was performed. The Dart Tag, UWT-1500 to be installed inside the host unit of Zebra Technologies Corporation (model UWT2100) has demonstrated compliance with all the stipulated standards referenced above. All references are to the most current version of Title 47 of the Code of Federal Regulations in effect. In accordance with §2.1033, the following data is presented in support of the Certification of the Zebra Technologies Corporation Dart Tag, UWT-1500. Zebra Technologies Corporation should retain a copy of this document which should be kept on file for at least two years after the manufacturing of the Dart Tag, UWT-1500 has been permanently discontinued.

Type of Submission/Rule:	Part 15.250 for WB Devices	
Model(s) Tested:	Dart Tag, UWT-1500	
EUT Specifications:	FCC ID:	XWX-UWT1500
	Primary Power:	2.4 – 3.3 VDC (battery powered)
	Modulation:	OOK
	Equipment Code:	WBT
Analysis:	The results obtained relate only to the item(s) tested.	
Evaluated by:	Donald Salguero	
Report Date(s):	May 21, 2019	

2.2 Test Site

All testing was performed at Eurofins MET Labs, Inc., 914 West Patapsco Avenue, Baltimore, MD 21230. All equipment used in making physical determinations is accurate and bears recent traceability to the National Institute of Standards and Technology.

Radiated Emissions measurements were performed inside of a semi-anechoic chamber. In accordance with §2.948(a)(3), a complete site description is contained at Eurofins MET Labs.

2.3 Description of Test Sample

The Zebra Technologies Corporation Dart Tag, UWT-1500, Equipment Under Test (EUT), is a a battery-operated device that is features a small circular form factor and affixed to assets. UWT-1500 transmissions are extremely short in duration providing excellent real-time location accuracy, long battery life and high tag throughput. Device is dust and waterproof and is built with robust components designed to withstand multiple six-foot drops. It is intended to be used by professionals for inside and outside environments.

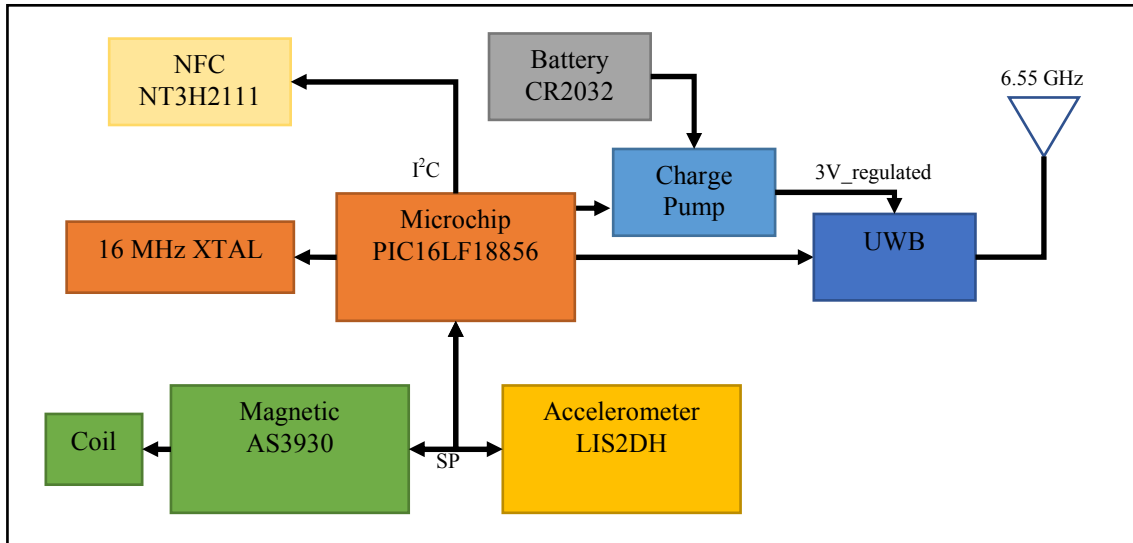

Figure 1. Block Diagram of Dart Tag, UWT-1500

2.4 Equipment Configuration

All equipment incorporated as part of the EUT is included in the following list.

Name / Description	Model Number	Serial Number
RFID Tag	UWT-1500	

Table 2. Equipment Configuration

2.4 Support Equipment

All equipment incorporated as part of the EUT is included in the following list.

Ref. ID	Name / Description	Manufacturer	Model Number	*Customer Supplied Calibration Data
	DartWand	Zebra	WND-3100	Yes
	Laptop	HP	HP EliteBook 840 G3	
	Laptop Charger	HP	HP Part No.: 740015-003	

The 'Customer Supplied Calibration Data' column will be marked as either not applicable, not available, or will contain the calibration date supplied by the customer.

Table 3. Support Equipment

2.4 Ports and Cabling Information

The EUT did not have any ports and cabling for operation or monitoring.

2.7 Mode of Operation

There are no physical connections. Through a 125kHz magnetic interface, data content and rate are variable. For test purposes, the EUT can be configured to settings that would provide that maximum emissions; packets of 184 bits containing 169 pulses of 2 nsec duration at a data rate of 1Mbps or packets of 112bits containing 95 pulses of 2 nsec duration at a data rate of 2Mbps, with a packet rate of 200 packets/sec.

2.8 Monitoring Method

Once device starts transmission, there is no additional configuration needed. This transmission is detectable with a sensor/receiver, which is a part of the Dart system. The Dart system detects the transmission. The information is monitored by using a PC connected to the Dart system. A USB-based Dart receiver will be used to activate the device, select its operating mode, and monitor its output.

2.9 Modifications

2.9.1 Modifications to EUT

No modifications were made to the EUT.

2.9.2 Modifications to Test Standard

No modifications were made to the test standard.

2.10 Disposition of EUT

The test sample including all support equipment submitted to the Electro-Magnetic Compatibility Lab for testing was returned to Zebra Technologies Corporation upon completion of testing.

3. Electromagnetic Compatibility Criteria for WB Devices

3.1 Antenna Requirement

Test Requirement: § 15.203: The structure and application of the EUT were analyzed to determine compliance with Section 15.203 of the Rules. Section 15.203 states that the subject device must meet at least one of the following criteria:

- a.) Antenna must be permanently attached to the unit.
- b.) Antenna must use a unique type of connector to attach to the EUT.
- c.) Unit must be professionally installed. Installer shall be responsible for verifying that the correct antenna is employed with the unit.

Test Results: The EUT was compliant with the requirement(s) of this section.

Built-in Antenna (permanently attached)
Antenna Type: Monopole
Antenna Gain: 0dBi

Test Engineer: Donald Salguero

Test Date: April 8, 2019

3.2 -10 dB Bandwidth Requirements

Test Requirements: § 15.250(a)(b): The -10 dB bandwidth of a device operating under the provisions of this section must be contained within the 5925 and 7250 MHz band under all conditions of operation including the effects from stepped frequency, frequency hopping or other modulation techniques that may be employed as well as the frequency stability of the transmitter over expected variations in temperature and supply voltage. The -10 dB bandwidth of the fundamental emission shall be at least 50 MHz.

Test Procedure: Emissions were measured using a horn antenna placed very close to the EUT. Due to the extremely wide nature of WB emissions, special considerations were taken to make the bandwidth measurements. The RBW was set to 1 MHz and the VBW to 3 MHz. Cable loss, pre-amp, and antenna correction factors have been programmed into spectrum analyzer.

Test Results The EUT was compliant with the requirement(s) of this section. The EUT does not use frequency hopping or stepped frequency modulation schemes.

For 1Mbit data rate:

$$f_L = 6320 \text{ MHz}, f_H = 6786 \text{ MHz}$$

$$\text{Therefore, -10 dB bandwidth} = f_H - f_L = 466 \text{ MHz}$$

For 2Mbit data rate:

$$f_L = 6336 \text{ MHz}, f_H = 6770 \text{ MHz}$$

$$\text{Therefore, -10 dB bandwidth} = f_H - f_L = 434 \text{ MHz}$$

Test Engineer: Donald Salguero

Test Dates: March 20, 2019

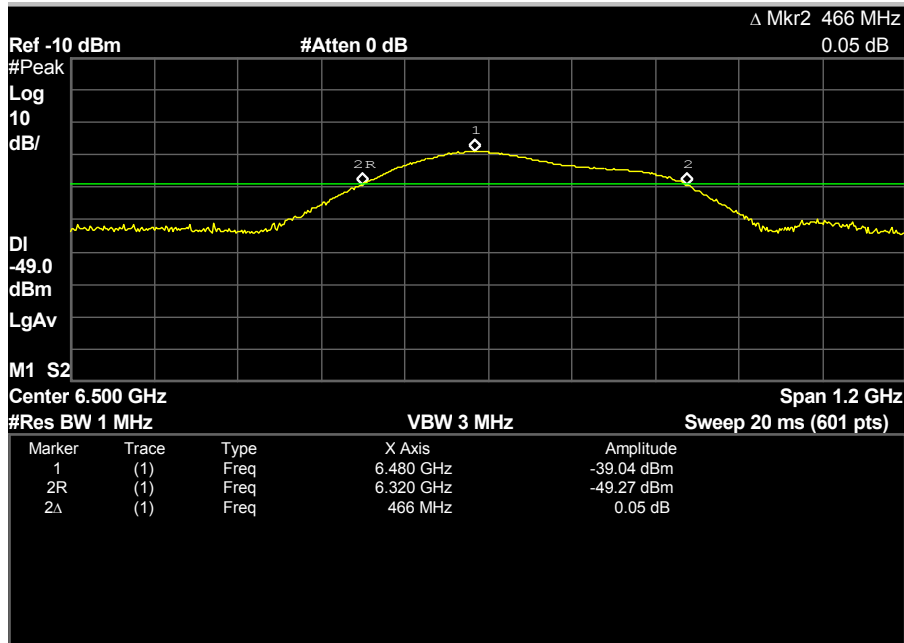

Plot 1. -10 dB Bandwidth, 1 MBit

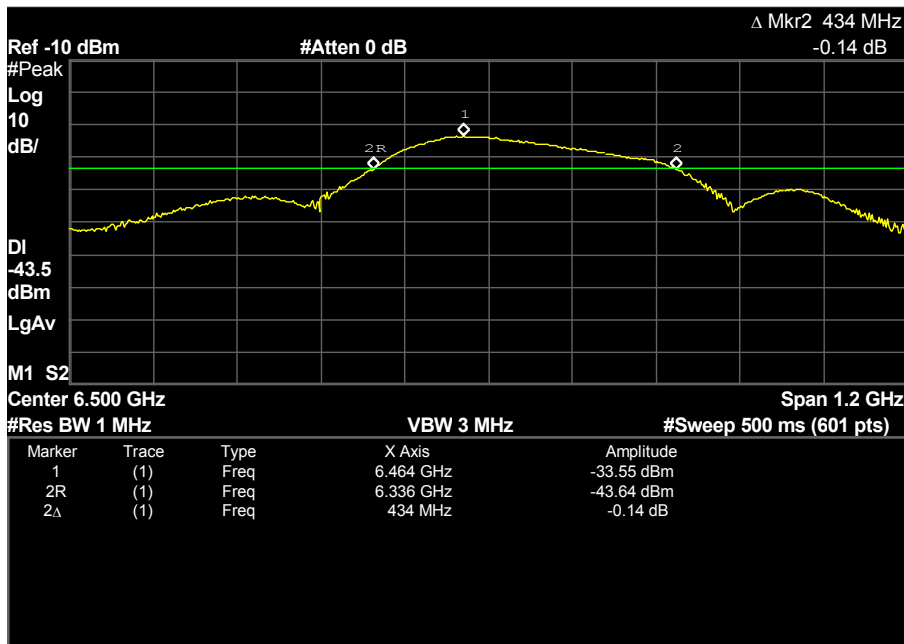

Plot 2. -10 dB Bandwidth, 2 MBit

3.3 Operational Restrictions

Transmitter Requirements: §15.250(c): Technical Requirements for WB systems.

Operation under the provisions of this section is limited to WB transmitters employed in the following limitations;

- (1) Operation on board an aircraft or a satellite is prohibited.
- (2) Devices operating under this section may not be employed for the operation of toys.
- (3) Except for operation onboard a ship or a terrestrial transportation vehicle, the use of a fixed outdoor infrastructure is prohibited. A fixed infrastructure includes antennas mounted on outdoor structures, e.g., antennas mounted on the outside of a building or on a telephone pole.

Test Results: The EUT was compliant with this requirement.
As per the customer's user manual, the EUT is to be used for tracking of a football for all spatial orientations. Additionally, it lists the above limitations.

Test Engineer: Donald Salguero

Test Dates: March 20, 2019

3.4 Radiated Emissions Above 960 MHz RMS Average

Test Requirements: § 15.250 (d)(1): Emissions from a transmitter operating under this section shall not exceed the following equivalent isotropically radiated power (EIRP) density levels:

Radiated Emissions above 960 MHz from a device operating under this section shall not exceed the average limits of Table 4 when measured using a RBW of 1 MHz.

Frequency in MHz	EIRP in dBm
960 - 1610	-75.3
1610 - 1990	-63.3
1990 - 3100	-61.3
3100 - 5925	-51.3
5925-7250	-41.3
7250-10600	-51.3
Above 10600	-61.3

Table 4. Limits for Radiated Emissions (RBW = 1MHz)

(e)(1) Unless otherwise specified, all RMS average emission levels specified in this section are to be measured utilizing a 1 MHz resolution bandwidth with a one millisecond dwell over each 1 MHz segment. The frequency span of the analyzer should equal the number of sampling bins times 1 MHz and the sweep rate of the analyzer should equal the number of sampling bins times one millisecond. The provision in § 15.35(c) that allows emissions to be averaged over a 100 millisecond period does not apply to devices operating under this section. The video bandwidth of the measurement instrument shall not be less than the resolution bandwidth and trace averaging shall not be employed. The RMS average emission measurement is to be repeated over multiple sweeps with the analyzer set for maximum hold until the amplitude stabilizes.

Test Procedure: The EUT was placed on a pedestal inside a fully-anechoic chamber. A horn antenna with a pre-amp was placed at various distances away from the EUT and measurements made. Measurements were performed with the EUT oriented in 3 orthogonal axis and rotated 360 degrees to determine worst case orientation for maximum emissions.

Cable loss, pre-amp, distance correction, and antenna correction factors have been programmed into the spectrum analyzer. Due to noise level limitations above 10.6GHz, the measurements were performed on a conducted setup. The antenna peak gain was added as an offset to show compliance to EIRP limits.

Frequency determining parameters: The highest frequency employed in §15.33 to determine the frequency range over which radiated emissions are made were based on the center frequency, f_c , unless a higher frequency was generated within the WB device. For measuring emission levels, the spectrum were investigated from the lowest frequency generated in the WB, without going below 9 kHz, up to the frequency range shown in Section 15.33(a) of the CFR 47 or up to $f_c + 3/(\text{pulse width in seconds})$, whichever was higher. There is no requirement to measure emissions beyond 40 GHz provided f_c was less than 10 GHz; beyond 100 GHz if f_c was at or above 10 GHz and below 30 GHz; or beyond 200 GHz if f_c was at or above 30 GHz.

Test Results: The EUT was compliant with the requirement(s) of this section. Measured emissions were within applicable limits.

The Radiated Emissions plots are cumulative. The spectrum analyzer Max Hold function was used while scanning Horizontal and Vertical polarization one after the other to show a worst case result.

Test Engineer: Donald Salguero

Test Dates: April 4, 2019

Frequency (MHz)	Rate (Mbit)	EIRP (dBm)	Limit (dBm)
6320-6786	1	-44.14	-41.3
6336-6770	2	-46.70	-41.3

Table 5. Radiated Emissions above 960MHz, Test Results

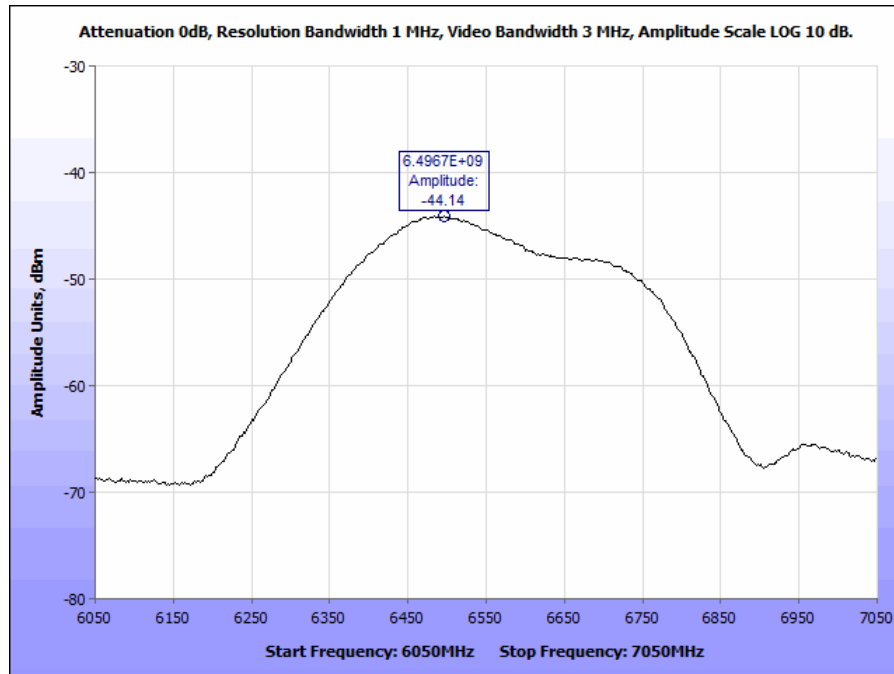

Plot 12. Radiated Emissions Above 960 MHz, Average, Fundamental Emission, 1 MBit

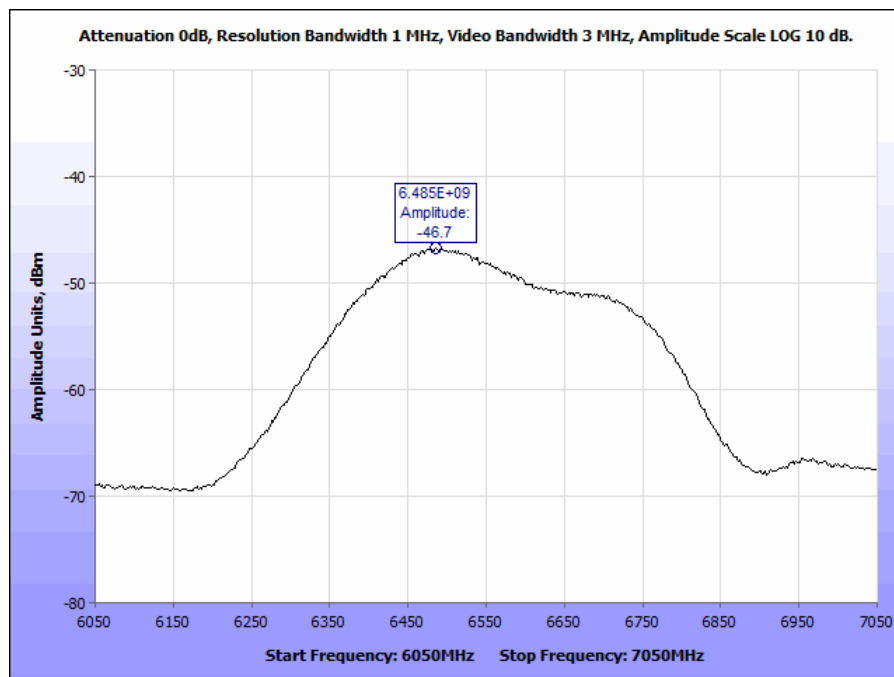

Plot 13. Radiated Emissions Above 960 MHz, Average, Fundamental Emission, 2M Bit

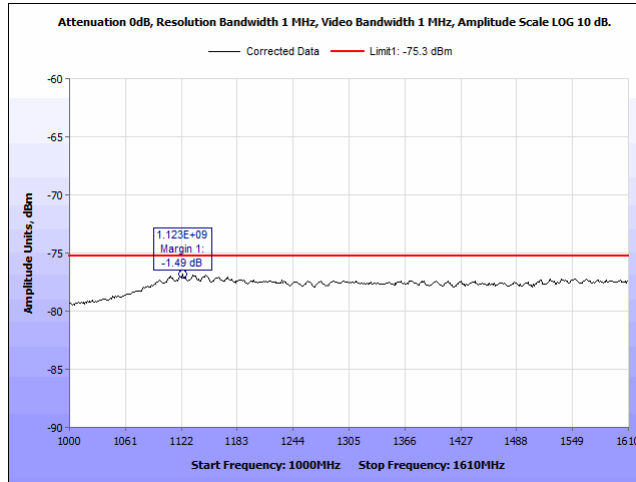

Plot 15. Radiated Emissions Above 960 MHz, Average, 1 Mbit, 1000 – 1610 MHz

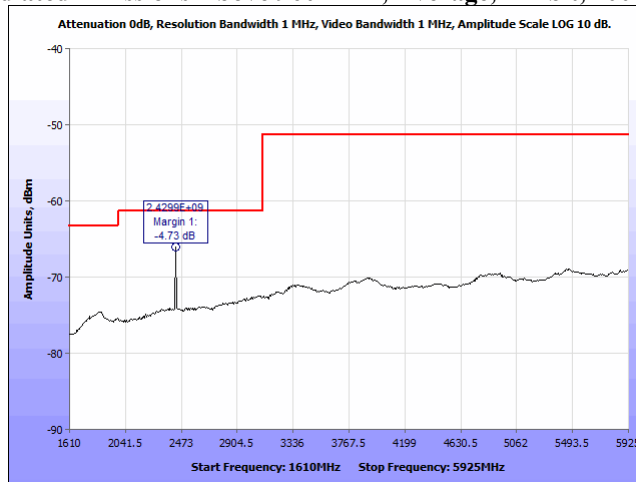

Plot 16. Radiated Emissions Above 960 MHz, Average, 1 MBit, 1610 – 5925 MHz

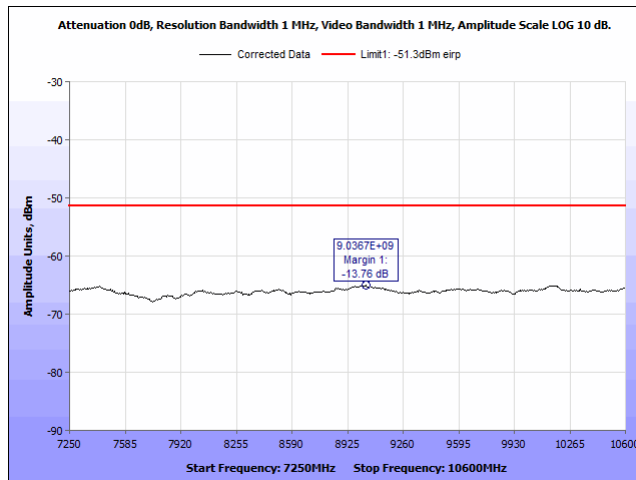

Plot 17. Radiated Emissions Above 960 MHz, Average, 1 Mbit, 7250 – 10600 MHz

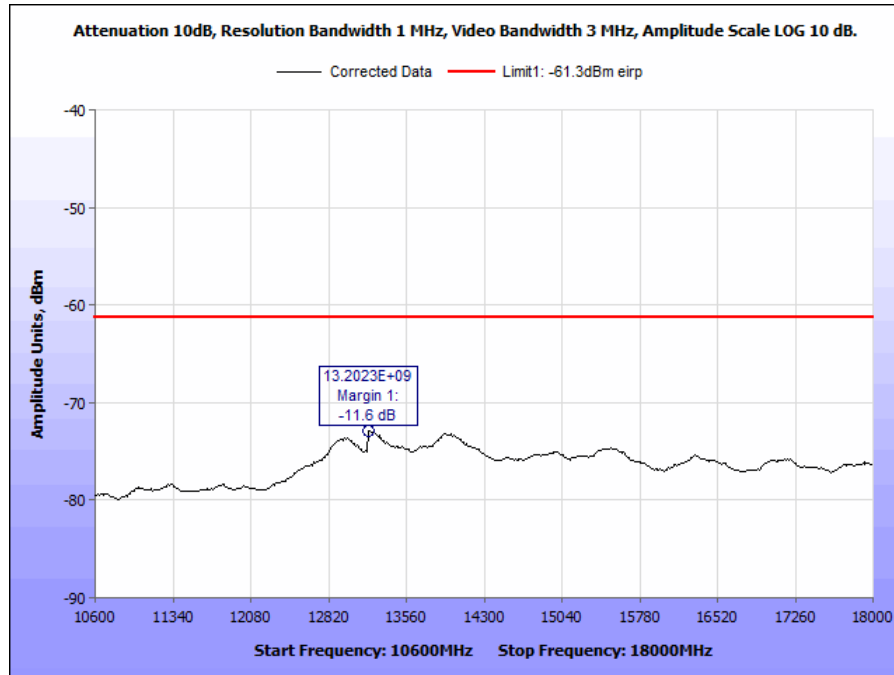

Plot 18. Radiated Emissions Above 960 MHz, Average, 1 Mbit, 10600 – 18000 MHz, Conducted

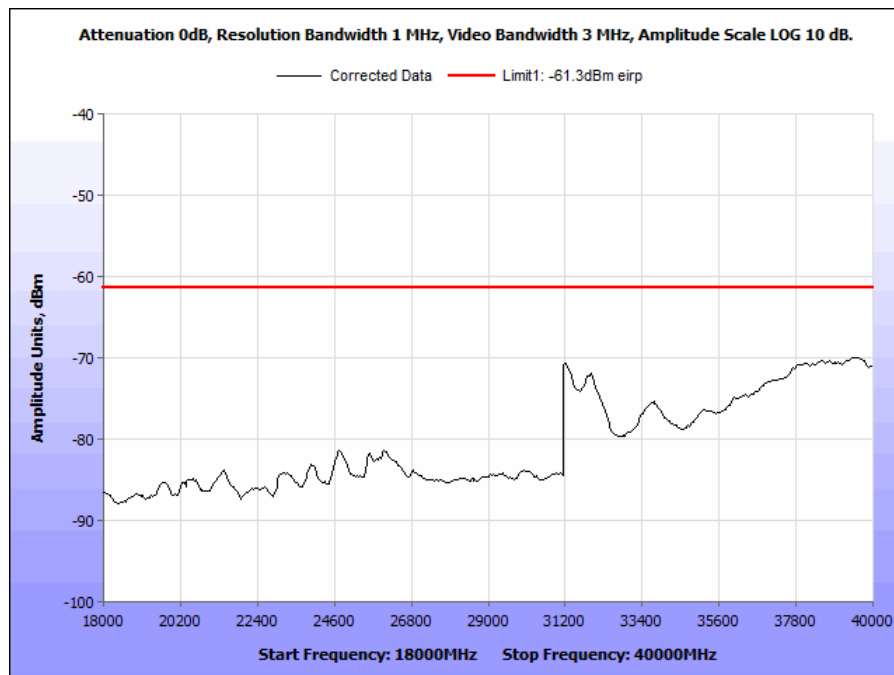

Plot 19. Radiated Emissions Above 960 MHz, Average, 1 Mbit, 18000 – 40000 MHz, Conducted

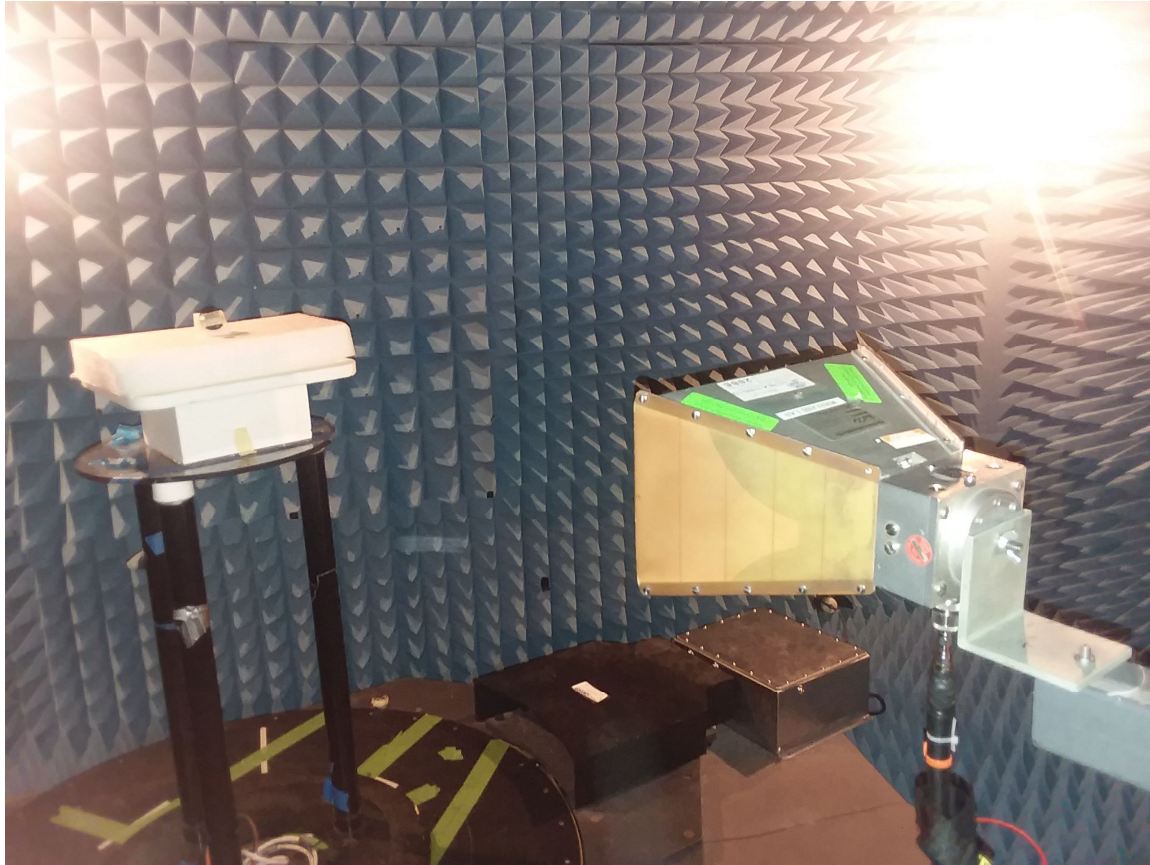

Photograph 1. Radiated emissions above 1GHz, Test Setup

3.5 GPS emissions

Test Requirements: §15.250(d)(2): In addition to the radiated emission limits specified in the table in paragraph (d)(1) of this section, transmitters operating under the provisions of this section shall not exceed the following RMS average limits when measured using a resolution bandwidth of no less than 1 kHz:

Frequency in MHz	EIRP in dBm
1164 - 1240	-85.3
1559 - 1610	-85.3

Table 6. Limits for Radiated Emissions (RBW >= 1kHz)

Test Procedure: The EUT was placed on a pedestal inside a semi-anechoic chamber. A horn antenna with a pre-amp was placed at various distances away from the EUT and measurements made. Measurements were performed with the EUT oriented in 3 orthogonal axis and rotated 360 degrees to determine worst case orientation for maximum emissions.

Procedure 10.3.10 from ANSI C63.10 was followed to perform the measurements.

Test Results: The EUT was compliant with the requirement(s) of this section.

The Radiated Emissions plots are cumulative. The spectrum analyzer Max Hold function was used while scanning Horizontal and Vertical polarization one after the other to show a worst case result.

Test Engineer: Donald Salguero

Test Date: April 12, 2019

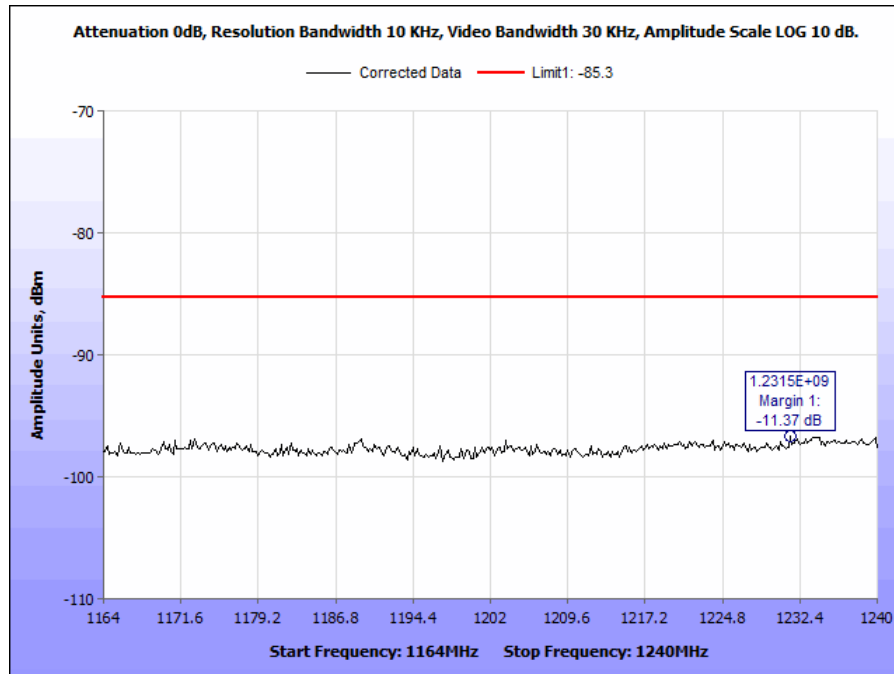

Plot 32. GPS Bands, Band 1

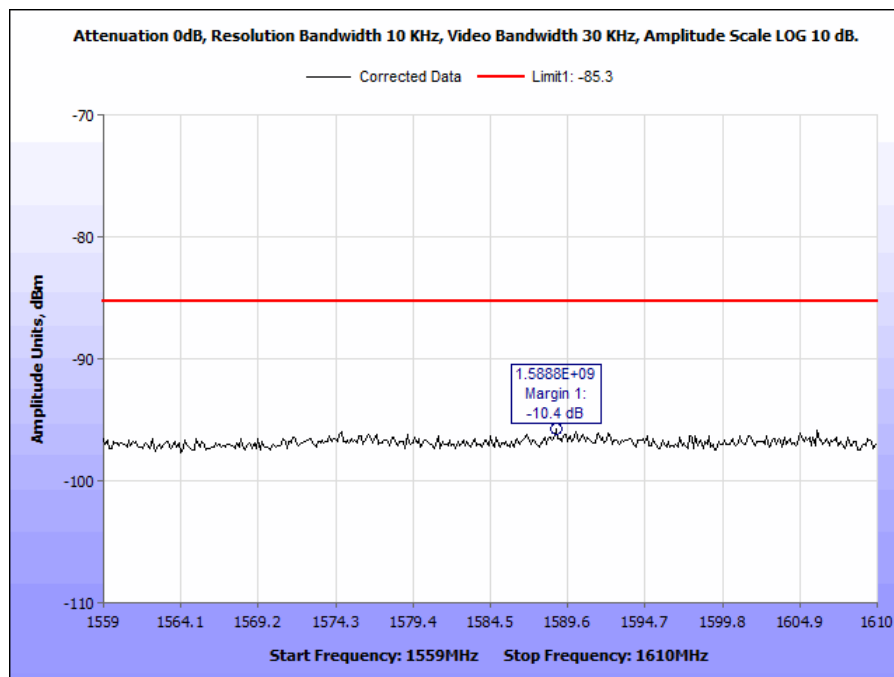

Plot 33. GPS Bands, Band 2

3.6 Peak Radiated Emissions Requirements

Test Requirements: §15.250(d) (3): There is a limit on the peak level of the emissions contained within a 50 MHz bandwidth centered on the frequency at which the highest radiated emission occurs and this 50 MHz bandwidth must be contained within the 5925–7250 MHz band. The peak EIRP limit is $20 \log (RBW/50)$ dBm where RBW is the resolution bandwidth in megahertz that is employed by the measurement instrument. RBW shall not be lower than 1 MHz or greater than 50 MHz. The video bandwidth of the measurement instrument shall not be less than RBW. If RBW is greater than 3 MHz, the application for certification filed with the Commission shall contain a detailed description of the test procedure, calibration of the test setup, and the instrumentation employed in the testing.

Calculation of Limit: The Offset was added to reflect measurements conducted at 2m.

(e)(2) The peak emission measurement is to be repeated over multiple sweeps with the analyzer set for maximum hold until the amplitude stabilizes.

Test Procedure: The EUT was placed on a pedestal inside a semi-anechoic chamber. A horn antenna with a pre-amp was placed at various distances away from the EUT and measurements made. Measurements were performed with the EUT oriented in 3 orthogonal axis and rotated 360 degrees to determine worst case orientation for maximum emissions. RBW was set to 3MHz.

Test Results: The EUT was compliant with the requirements of §15.250(d)(3). Measured emissions were within applicable limits.

Test Engineer: Donald Salguero

Test Date: March 20, 2019

Frequency (MHz)	Rate (Mbit)	EIRP (dBm)	Limit $20 * \text{Log}[\text{RBW}/50]$ (dBm)
6320-6786	1	-24.84	-24.43
6336-6770	2	-25.10	-24.43

Table 7. Peak Radiated Emissions, Test Results

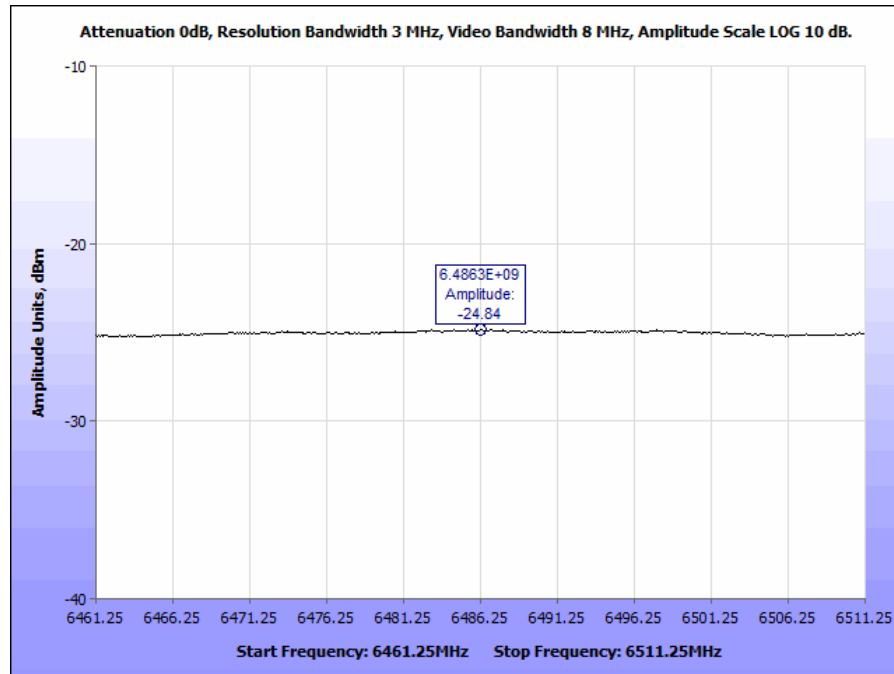

Plot 36. Peak Emissions, Fundamental Emission, 1 MBit

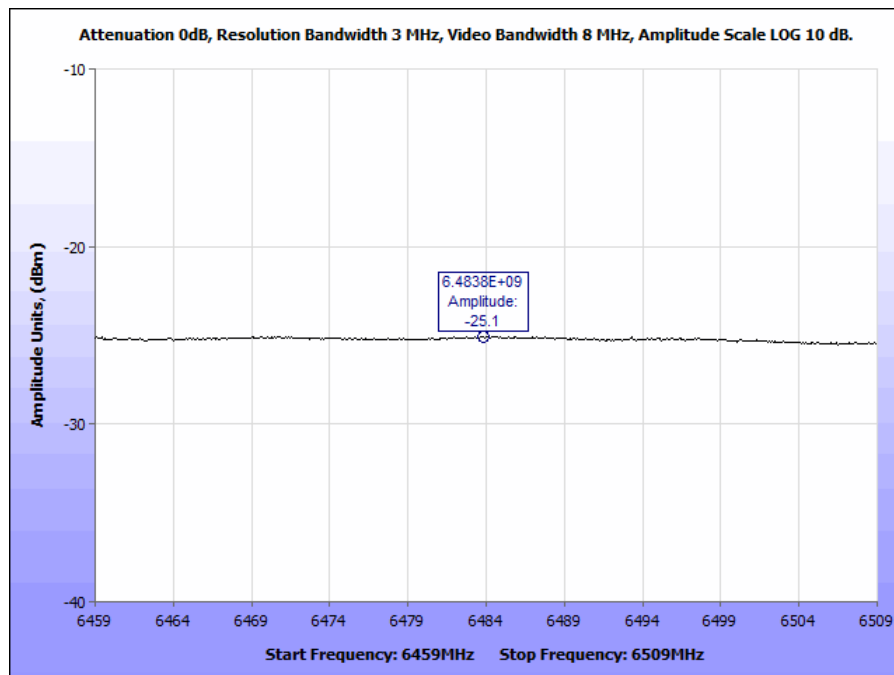

Plot 37. Peak Emissions, Fundamental Emission, 2 MBit

3.7 15.250(d)(4) Radiated emissions below 960 MHz

Test Requirements: § 15.250 (d)(4): Radiated emissions at or below 960 MHz shall not exceed the emission levels in § 15.209.

§ 15.209 (a) Except as provided elsewhere in this subpart, the emissions from an intentional radiator shall not exceed the field strength levels specified in Table 8.

Frequency (MHz)	§15.209(a), Radiated Emission Limits (dB:V) @ 3m
30 - 88	40.00*
88 - 216	43.50*
216 - 960	46.00*
Above 960	54.00

* -- Except perimeter protection systems operating under paragraph (g), fundamental emissions from intentional radiators operating under this Section shall not be located in the frequency bands 54-72 MHz, 76-88 MHz, 174-216 MHz or 470-806 MHz. However, operation within these frequency bands is permitted under other sections of this Subpart.

Table 8. Radiated Emissions Limits Calculated from FCC Part 15, § 15.209 (a)

Test Procedure: The EUT was placed on a 0.8m pedestal inside a semi-anechoic chamber. A measurement antenna was placed 3 m away from the EUT. The EUT was rotated about all three orthogonal axis while a pre-scan was performed. The antenna was varied between 1 m and 4 m, in both horizontal and vertical polarities.

The Radiated Emission plot is cumulative. The spectrum analyzer Max Hold function was used while scanning Horizontal and Vertical polarization one after the other to show a worst case result.

Test Results: The EUT was compliant with the requirement(s) of this section.

Test Engineer: Donald Salguero

Test Date: April 4, 2019

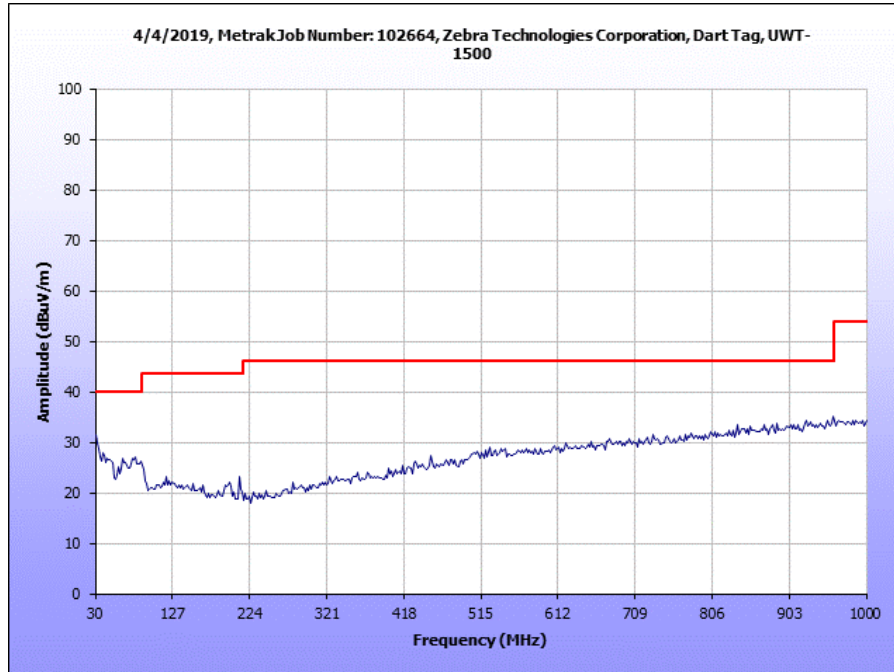

Plot 38. Radiated Emissions Below 960 MHz, 30 – 1000 MHz



Photograph 2. Radiated Emissions, Test Setup

4.0 Test Equipment

Calibrated test equipment utilized during testing was maintained in a current state of calibration per the requirements of ISO/IEC 17025:2005.

MET Asset #	Equipment	Manufacturer	Model	Last Cal Date	Cal Due Date
1T4409	EMI Receiver	Rohde & Schwarz	ESIB7	1/4/2019	1/4/2021
1T4753	Antenna - Bilog	Sunol Sciences	JB6	8/30/2018	2/29/2020
1T4300A	SEMI-ANECHOIC CHAMBER # 1 (FCC)	EMC TEST SYSTEMS	NONE	1/30/2019	6/30/2020
1T8743	Preamplifier	A.H. Systems, Inc.	PAM-0118P	Func Verify	
1T2665	Antenna; Horn	EMCO	3115	6/22/2017	6/22/2019
1T4771	PSA Spectrum Analyzer	Agilent Technologies	E4446A	05/16/2018	11/16/2019
1T4149	High-Frequency Anechoic Chamber	Ray Proof	81	Not Required	

Note: Functionally verified test equipment is verified using calibrated instrumentation at the time of testing.

5.0 Compliance Information

5.1 Certification Information

The following is extracted from Title 47 of the Code of Federal Regulations, Part 2, Subpart I — Marketing of Radio frequency devices:

§ 2.801 Radio-frequency device defined.

As used in this part, a radio-frequency device is any device which in its operation is capable of Emitting radio-frequency energy by radiation, conduction, or other means. Radio- frequency devices include, but are not limited to:

- (a) The various types of radio communication transmitting devices described throughout this chapter.
- (b) *The incidental, unintentional and intentional radiators defined in Part 15 of this chapter.*
- (c) The industrial, scientific, and medical equipment described in Part 18 of this chapter.
- (d) Any part or component thereof which in use emits radio-frequency energy by radiation, conduction, or other means.

§ 2.803 Marketing of radio frequency devices prior to equipment authorization.

- (a) Except as provided elsewhere in this chapter, no person shall sell or lease, or offer for sale or lease (including advertising for sale or lease), or import, ship or distribute for the purpose of selling or leasing or offering for sale or lease, any radio frequency device unless:
 - (1) In the case of a device subject to certification, such device has been authorized by the Commission in accordance with the rules in this chapter and is properly identified and labeled as required by §2.925 and other relevant sections in this chapter; or
 - (2) In the case of a device that is not required to have a grant of equipment authorization issued by the Commission, but which must comply with the specified technical standards prior to use, such device also complies with all applicable administrative (including verification of the equipment or authorization under a Declaration of Conformity, where required), technical, labeling and identification requirements specified in this chapter.
- (d) Notwithstanding the provisions of paragraph (a) of this section, the offer for sale solely to business, commercial, industrial, scientific or medical users (but not an offer for sale to other parties or to end users located in a residential environment) of a radio frequency device that is in the conceptual, developmental, design or pre-production stage is permitted prior to equipment authorization or, for devices not subject to the equipment authorization requirements, prior to a determination of compliance with the applicable technical requirements *provided* that the prospective buyer is advised in writing at the time of the offer for sale that the equipment is subject to the FCC rules and that the equipment will comply with the appropriate rules before delivery to the buyer or to centers of distribution.

- (e)(1) Notwithstanding the provisions of paragraph (a) of this section, prior to equipment authorization or determination of compliance with the applicable technical requirements any radio frequency device may be operated, but not marketed, for the following purposes and under the following conditions:
- (i) *Compliance testing;*
 - (ii) Demonstrations at a trade show provided the notice contained in paragraph (c) of this section is displayed in a conspicuous location on, or immediately adjacent to, the device;
 - (iii) Demonstrations at an exhibition conducted at a business, commercial, industrial, scientific or medical location, but excluding locations in a residential environment, provided the notice contained in paragraphs (c) or (d) of this section, as appropriate, is displayed in a conspicuous location on, or immediately adjacent to, the device;
 - (iv) Evaluation of product performance and determination of customer acceptability, provided such operation takes place at the manufacturer's facilities during developmental, design or pre-production states; or
 - (v) Evaluation of product performance and determination of customer acceptability where customer acceptability of a radio frequency device cannot be determined at the manufacturer's facilities because of size or unique capability of the device, provided the device is operated at a business, commercial, industrial, scientific or medical user's site, but not at a residential site, during the development, design or pre-production stages.
- (e)(2) For the purpose of paragraphs (e)(1)(iv) and (e)(1)(v) of this section, the term *manufacturer's facilities* includes the facilities of the party responsible for compliance with the regulations and the manufacturer's premises, as well as the facilities of other entities working under the authorization of the responsible party in connection with the development and manufacture, but not the marketing, of the equipment.
- (f) For radio frequency devices subject to verification and sold solely to business, commercial, industrial, scientific and medical users (excluding products sold to other parties or for operation in a residential environment), parties responsible for verification of the devices shall have the option of ensuring compliance with the applicable technical specifications of this chapter at each end user's location after installation, provided that the purchase or lease agreement includes a proviso that such a determination of compliance be made and is the responsibility of the party responsible for verification of the equipment.

The following is extracted from Title 47 of the Code of Federal Regulations, Part 2, and Subpart J— Equipment Authorization Procedures:

§ 2.901 Basis and Purpose

- (a) In order to carry out its responsibilities under the Communications Act and the various treaties and international regulations, and in order to promote efficient use of the radio spectrum, the Commission has developed technical standards for radio frequency equipment and parts or components thereof. The technical standards applicable to individual types of equipment are found in that part of the rules governing the service wherein the equipment is to be operated.¹ *In addition to the technical standards provided, the rules governing the service may require that such equipment be verified by the manufacturer or importer*, be authorized under a Declaration of Conformity, or receive an equipment authorization from the Commission by one of the following procedures: certification or registration.
- (b) The following sections describe the verification procedure, the procedure for a Declaration of Conformity, and the procedures to be followed in obtaining certification from the Commission and the conditions attendant to such a grant.

§ 2.907 Certification

- (a) Certification is an equipment authorization issued by the Commission, based on representation and test data submitted by the applicant.
- (b) Certification attaches to all units subsequently marketed by the grantee which are identical (see Section 2.908) to the sample tested except for permissive changes or other variations authorized by the Commission pursuant to Section 2.1043.

¹ In this case, the equipment is subject to the rules of Part 15. More specifically, the equipment falls under Subpart B (of Part 15), which deals with unintentional radiators.

§ 2.948 Description of measurement facilities.

- (a) Each party making measurements of equipment that is subject to an equipment authorization under Part 15 or Part 18 of this chapter, regardless of whether the measurements are filed with the Commission or kept on file by the party responsible for compliance of equipment marketed within the U.S. or its possessions, shall compile a description of the measurement facilities employed.
- (1) If the measured equipment is subject to the verification procedure, the description of the measurement facilities shall be retained by the party responsible for verification of the equipment.
- (i) *If the equipment is verified through measurements performed by an independent laboratory, it is acceptable for the party responsible for verification of the equipment to rely upon the description of the measurement facilities retained by or placed on file with the Commission by that laboratory. In this situation, the party responsible for the verification of the equipment is not required to retain a duplicate copy of the description of the measurement facilities.*
- (ii) If the equipment is verified based on measurements performed at the installation site of the equipment, no specific site calibration data is required. It is acceptable to retain the description of the measurement facilities at the site at which the measurements were performed.
- (2) If the equipment is to be authorized by the Commission under the certification procedure, the description of the measurement facilities shall be filed with the Commission's Laboratory in Columbia, Maryland. The data describing the measurement facilities need only be filed once but must be updated as changes are made to the measurement facilities or as otherwise described in this section. At least every three years, the organization responsible for filing the data with the Commission shall certify that the data on file is current.