



MET Laboratories, Inc. *Safety Certification - EMI - Telecom Environmental Simulation*

914 WEST PATAPSCO AVENUE • BALTIMORE, MARYLAND 21230-3432 • PHONE (410) 354-3300 • FAX (410) 354-3313
33439 WESTERN AVENUE • UNION CITY CALIFORNIA 94587 • PHONE (510) 489-6300 • FAX (510) 489-6372
3162 BELICK STREET • SANTA CLARA CALIFORNIA 95054 • PHONE (408) 748-3585 • FAX (510) 489-6372
13301 MCCALLEN PASS • AUSTIN TEXAS 78753 • PHONE (512) 287-2500 • FAX (512) 287-2513

March 7, 2014

Zebra Technologies Corporation
333 Corporate Woods Parkway
Vernon Hills, IL 60061-3109

Dear Gus Medina,

Enclosed is the EMC test report for compliance testing of the Zebra Technologies Corporation, DartTag, Model: UWT-1300 as tested to the requirements of Title 47 of the CFR, Ch. 1 (10-1-03 ed.), Part 15, Subpart B, ICES-003, Issue 5, August 2012 for a Class B Digital Device and FCC Part 15 Subpart C, §15.250, RSS-220, Issue 1, March 2009 for Wideband Operation.

Thank you for using the services of MET Laboratories, Inc. If you have any questions regarding these results or if MET can be of further service to you, please feel free to contact me.

Sincerely yours,
MET LABORATORIES, INC.

Jennifer Warnell
Documentation Department

Reference: (\Zebra Technologies Corporation\EMC40937-FCC250 Rev. 1)

Certificates and reports shall not be reproduced except in full, without the written permission of MET Laboratories, Inc. This letter of transmittal is not a part of the attached report.

DOC-EMC702 2/26/2004



MET Laboratories, Inc. *Safety Certification - EMI - Telecom Environmental Simulation*

914 WEST PATAPSCO AVENUE • BALTIMORE, MARYLAND 21230-3432 • PHONE (410) 354-3300 • FAX (410) 354-3313
33439 WESTERN AVENUE • UNION CITY CALIFORNIA 94587 • PHONE (510) 489-6300 • FAX (510) 489-6372
3162 BELICK STREET • SANTA CLARA CALIFORNIA 95054 • PHONE (408) 748-3585 • FAX (510) 489-6372
13301 MCCALLEN PASS • AUSTIN TEXAS 78753 • PHONE (512) 287-2500 • FAX (512) 287-2513

**Electromagnetic Compatibility Criteria
Test Report**

For the

**Zebra Technologies Corporation
DartTag, Model: UWT-1300**

Tested under
the FCC Certification Rules
contained in
Title 47 of the CFR, Parts 15 Subpart B & ICES-003
for Class B Digital Devices
&
15.250 Subpart C & RSS-220, Issue 1, March 2009
for Wideband Operation

MET Report: EMC40937-FCC250 Rev. 1

March 7, 2014

Prepared For:

**Zebra Technologies Corporation
333 Corporate Woods Parkway
Vernon Hills, IL 60061-3109**

**Prepared By:
MET Laboratories, Inc.**
914 W. Patapsco Ave.
Baltimore, MD 21230



Electromagnetic Compatibility Criteria Test Report

For the

Zebra Technologies Corporation
DartTag, Model: UWT-1300

Tested Under
the FCC Certification Rules
contained in
Title 47 of the CFR, Parts 15 Subpart B & ICES-003
for Class B Digital Devices
&
15.250 Subpart C & RSS-220, Issue 1, March 2009
for Wideband Operation

Shawn McMillen, Project Engineer
Electromagnetic Compatibility Lab

Jennifer Warnell
Documentation Department

Engineering Statement: The measurements shown in this report were made in accordance with the procedures indicated, and the emissions from this equipment were found to be within the limits applicable. I assume full responsibility for the accuracy and completeness of these measurements, and for the qualifications of all persons taking them. It is further stated that upon the basis of the measurements made, the equipment tested is capable of operation in accordance with the requirements of Part 15B & §15.250 of the FCC Rules, and ICES-003 Issue 5, August 2012 & RSS-220 of the Industry Canada Rules under normal use and maintenance.

Asad Bajwa
Director, Electromagnetic Compatibility Lab



Report Status Sheet

Revision	Report Date	Reason for Revision
Ø	March 6, 2014	Initial Issue.
1	March 7, 2014	Revised to reflect engineer corrections.



Table of Contents

1.0	Requirements Summary	1
2.0	Equipment Configuration	2
	Overview	2
	Test Site	2
	Description of Test Sample	2
	Equipment Configuration	4
	Mode of Operation	4
	Frequency Determining Parameters	4
	Modifications	4
	Modifications to EUT	4
	Modifications to Test Standard	4
	Disposition of EUT	4
3.0	Electromagnetic Compatibility Emission Criteria	5
	Conducted Emission Limits	5
	Radiated Emission Limits	6
4.0	Electromagnetic Compatibility Criteria for WB Devices	8
	Antenna Requirement	8
	§ 15.207(a) Conducted Emissions Limits	9
	- 10 dB Bandwidth Requirements	10
	Operational Restrictions	15
	Radiated Emissions Above 960 MHz	16
	GPS emissions	25
	Peak Radiated Emissions	28
	Radiated emissions below 960 MHz	30
5.0	Test Equipment	32
6.0	Compliance Information	33
	Certification Information	33



List of Tables

Table 1. Requirements Summary of EMC Part 15.250 Compliance Testing	1
Table 2. Equipment Configuration	4
Table 3. Conducted Limits for Radio Frequency Devices calculated from FCC Part 15 Subsections 15.107(a) (b)	5
Table 4. Radiated Emissions Limits calculated from FCC Part 15, §15.109 (a) (b)	6
Table 5. Radiated Emissions, Test Results	7
Table 6. Conducted Limits for Intentional Radiators from FCC Part 15 § 15.207(a)	9
Table 7. Limits for Radiated Emissions (RBW = 1MHz)	16
Table 8. Limits for Radiated Emissions, RSS-220	16
Table 9. Limits for Radiated Emissions (RBW \geq 1kHz)	25
Table 10. Radiated Emissions Limits Calculated from FCC Part 15, § 15.209 (a)	30



List of Terms and Abbreviations

AC	Alternating Current
ACF	Antenna Correction Factor
Cal	Calibration
d	Measurement Distance
dB	Deci Bels
dBΦV	Deci-Bels above one micro Volt
dBΦV/m	Deci-Bels above one micro Volt per meter
DC	Direct Current
DCF	Distance Correction Factor
E	Electric Field
DSL	Digital Subscriber Line
ESD	Electrostatic Discharge
EUT	Equipment Under Test
f	Frequency
FCC	Federal Communications Commission
H	Magnetic Field
GHz	Giga Hertz
Hz	Hertz
ICES	Interference-Causing Equipment Standard
kHz	kilohertz
kPa	kilopascal
kV	kilo Volt
LISN	Line Impedance Stabilization Network
MHz	MegaHertz
ΦH	micro Henry
ΦF	micro Farad
Φs	micro seconds
RF	Radio Frequency
RMS	Root-Mean-Square
V/m	Volts per meter
WB	Wideband



1.0 Requirements Summary

The following tests were performed on a sample of the equipment for the purpose of demonstrating compliance with Part 15, Subpart C, §15.250, in accordance with Zebra Technologies Corporation Purchase Order Number 111092959.

FCC Reference	IC Reference	Description	Compliance
Title 47 of the CFR, Part 15, Subpart B, §15.107	ICES-003	Conducted Emissions – Class A	Not Applicable – The EUT is battery powered.
Title 47 of the CFR, Part 15, Subpart B, §15.109	ICES-003	Radiated Emissions – Class B	Compliant
Title 47 of the CFR, Part 15, Subpart C, §15.209(a)	RSS-220 5.1(b)	Antenna Requirements	Compliant
Title 47 of the CFR, Part 15, Subpart C, §15.207(a)	RSS-220 5.2.1(b)	Electromagnetic Compatibility - Conducted Emissions for Intentional Radiators	Not Applicable – The EUT is battery powered.
Title 47 of the CFR, Part 15, Subpart C, §15.250(a)(b)	RSS-220 5.1(a)	-10 dB Bandwidth	Compliant
Title 47 of the CFR, Part 15, Subpart C, §15.250(c)	RSS-GEN	Operational Restrictions	Applicant has been advised of these requirements.
Title 47 of the CFR, Part 15, Subpart C, §15.250(d)(1)	RSS-220 5.2.1(d)	Radiated emissions above 960 MHz (RMS Avg.)	Compliant
Title 47 of the CFR, Part 15, Subpart C, §15.250(d)(2)	RSS-220 5.2.1(e)	GPS emissions	Compliant
Title 47 of the CFR, Part 15, Subpart C, §15.250(d)(3)	RSS-220 5.2.1(g)	Peak emissions	Compliant
Title 47 of the CFR, Part 15, Subpart C, §15.250(d)(4)	RSS-220 5.2.1(c)	Radiated emissions below 960 MHz	Compliant

Table 1. Requirements Summary of EMC Part 15.250 Compliance Testing



2. Equipment Configuration

2.1 Overview

An EMC evaluation to determine compliance of the Zebra Technologies Corporation, DartTag, Model: UWT-1300 with the requirements of Part 15, Subpart C, §15.250 was performed. All references are to the most current version of Title 47 of the Code of Federal Regulations in effect. In accordance with §2.1033, the following data is presented in support of the Certification of the Zebra Technologies Corporation DartTag, Model: UWT-1300. Zebra Technologies Corporation should retain a copy of this document which should be kept on file for at least two years after the manufacturing of the DartTag, Model: UWT-1300 has been permanently discontinued.

Type of Submission/Rule:	Part 15.250 for WB Devices	
Model(s) Tested:	DartTag, Model: UWT-1300	
EUT Specifications:	FCC ID:	XWX-UWT1300
	IC:	8701A-UWT1300
	Equipment Code:	UWB
Analysis:	The results obtained relate only to the item(s) tested.	
Evaluated by:	Shawn McMillen	
Report Date(s):	March 7, 2014	

2.2 Test Site

All testing was performed at MET Laboratories, Inc., 914 W. Patapsco Avenue, Baltimore, Maryland 21230. All equipment used in making physical determinations is accurate and bears recent traceability to the National Institute of Standards and Technology.

Radiated Emissions measurements were performed inside of a semi-anechoic chamber. In accordance with §2.948(a)(3), a complete site description is contained at MET Laboratories.

2.3 Description of Test Sample

The Zebra Technologies Corporation DartTag, Model: UWT-1300, Equipment Under Test (EUT), is a UWB transmit device used for RTLS applications.

	UWT-1300
Dimensions	31.6x25.7x10.2mm
Weight	9.2g
Power (DC in)	0.54mW
Battery	CR2016
Data	184 bits

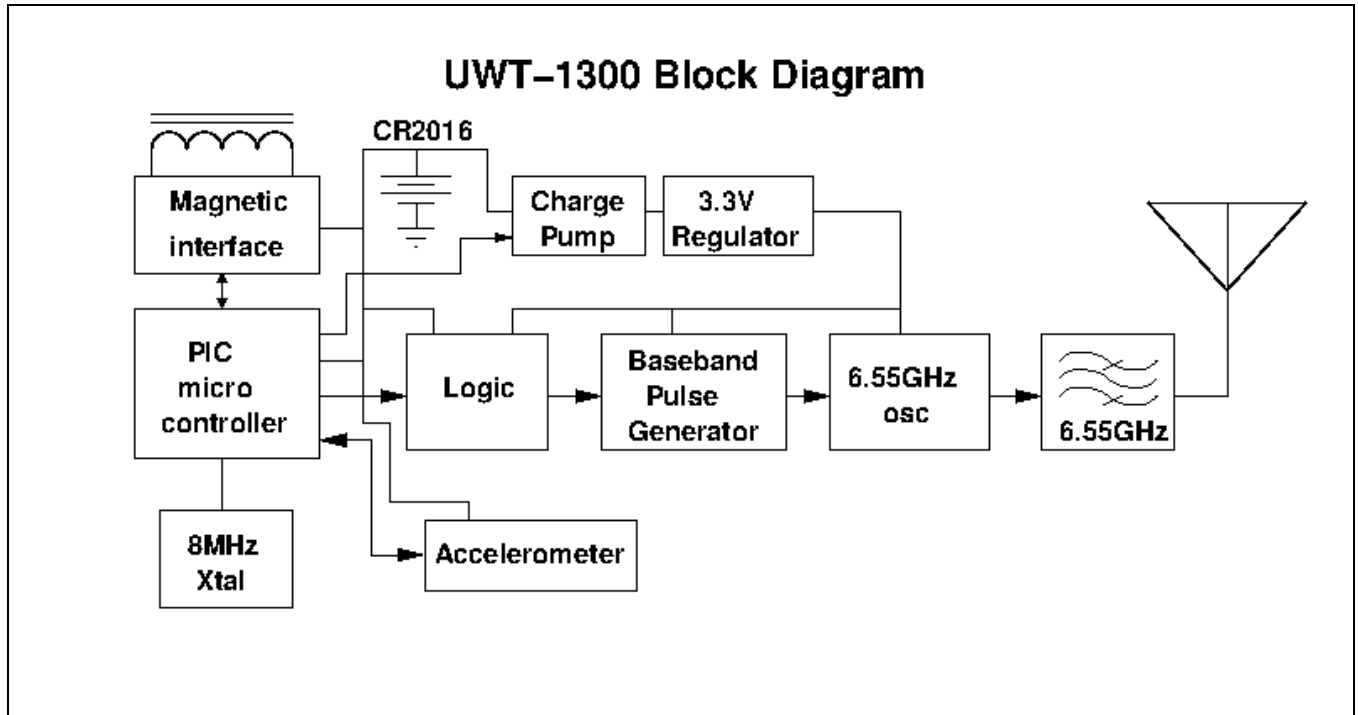

Figure 1. Block Diagram of Equipment Configuration



2.4 Equipment Configuration

All equipment incorporated as part of the EUT is included in the following list.

Name / Description	Model Number	Serial Number
Dart Tag	UWT-1300	--

Table 2. Equipment Configuration

2.7 Mode of Operation

There are no physical connections. Through a 125kHz magnetic interface, data content and rate are variable. For test purposes, the EUT was preconfigured to a setting that would provide that maximum emissions; packets of 184 bits containing 169 pulses of 2nsec duration at a data rate of 1Mbps or packets of 112 bits containing 95 pulses of 2nsec duration at a data rate of 2Mbps, with a packet rate of 200 packets/sec.

2.8 Frequency Determining Parameters

The highest frequency employed in §15.33 to determine the frequency range over which radiated emissions are made was based on the center frequency, f_c , unless a higher frequency was generated within the WB device. For measuring emission levels, the spectrum was investigated from the lowest frequency generated in the WB, without going below 9 kHz, up to the frequency range shown in Section 15.33(a) of the CFR 47 or up to $f_c + 3/(\text{pulse width in seconds})$, whichever was higher. There is no requirement to measure emissions beyond 40 GHz provided f_c was less than 10 GHz; beyond 100 GHz if f_c was at or above 10 GHz and below 30 GHz; or beyond 200 GHz if f_c was at or above 30 GHz.

2.9 Modifications

2.9.1 Modifications to EUT

No modifications were made to the EUT.

2.9.2 Modifications to Test Standard

No modifications were made to the test standard.

2.10 Disposition of EUT

The test sample including all support equipment submitted to the Electro-Magnetic Compatibility Lab for testing was returned to Zebra Technologies Corporation upon completion of testing.



3. Electromagnetic Compatibility Emission Criteria

3.1 Conducted Emission Limits

Test Requirement(s): **15.107 (a)** Except for Class A digital devices, for equipment that is designed to be connected to the public utility (AC) power line, the radio frequency voltage that is conducted back onto the AC power line on any frequency or frequencies within the band 150 kHz to 30 MHz shall not exceed the limits in Table 3. Compliance with this provision shall be based on the measurement of the radio frequency voltage between each power line and ground at the power terminals.

15.107 (b) For a Class A digital device that is designed to be connected to the public utility (AC) power line, the radio frequency voltage that is conducted back onto the AC power line on any frequency or frequencies within the band 150 kHz to 30 MHz shall not exceed the limits in Table 3. Compliance with this provision shall be based on the measurement of the radio frequency voltage between each power line and ground at the power terminals. The lower limit applies at the band edges.

Frequency range (MHz)	Class A Conducted Limits (dBµV)		*Class B Conducted Limits (dBµV)	
	Quasi-Peak	Average	Quasi-Peak	Average
* 0.15- 0.45	79	66	66 - 56	56 - 46
0.45 - 0.5	79	66	56	46
0.5 - 30	73	60	60	50

Note 1 — The lower limit shall apply at the transition frequencies.
 Note 2 — The limit decreases linearly with the logarithm if the frequency in the range 0.15 MHz to 0.5 MHz.

Table 3. Conducted Limits for Radio Frequency Devices calculated from FCC Part 15 Subsections 15.107(a) (b)

Test Results: The EUT was not applicable with the Class B requirement(s) of this section. The EUT is battery powered.



3.2 Radiated Emission Limits

Test Requirement(s): **15.109 (a)** Except for Class A digital devices, the field strength of radiated emissions from unintentional radiators at a distance of 3 meters shall not exceed the Class B limits expressed in Table 4.

15.109 (b) The field strength of radiated emissions from a Class A digital device, as determined at a distance of 10 meters, shall not exceed the Class A limits expressed in Table 4.

Frequency (MHz)	Field Strength (dBµV/m)	
	§15.109 (b), Class A Limit (dBµV) @ 10m	§15.109 (a), Class B Limit (dBµV) @ 3m
30 - 88	39.00	40.00
88 - 216	43.50	43.50
216 - 960	46.40	46.00
Above 960	49.50	54.00

Table 4. Radiated Emissions Limits calculated from FCC Part 15, §15.109 (a) (b)

Test Procedures: The EUT was placed on a non-metallic table, 80 cm above the ground plane inside a semi-anechoic chamber. The method of testing and test conditions of ANSI C63.4 were used. An antenna was located 3 m from the EUT on an adjustable mast. A pre-scan was first performed in order to find prominent radiated emissions. For final emissions measurements at each frequency of interest, the EUT was rotated and the antenna height was varied between 1 m and 4 m in order to maximize the emission. Measurements in both horizontal and vertical polarities were made and the data was recorded. Unless otherwise specified, measurements were made using a quasi-peak detector with a 120 kHz bandwidth.

Test Results: The EUT was compliant with the Class B requirement(s) of this section. Measured emissions were below applicable limits.

Test Engineer(s): Benjamin Taylor

Test Date(s): 02/03/14



Frequency (MHz)	EUT Azimuth (Degrees)	Antenna Polarity (H/V)	Antenna HEIGHT (m)	Uncorrected Amplitude (dB μ V)	Antenna Correction Factor (dB) (+)	Cable Loss (dB) (+)	Distance Correction Factor (dB) (-)	Corrected Amplitude (dB μ V/m)	Limit (dB μ V/m)	Margin (dB)
90.06012	348	H	1.03	5.10	7.81	0.73	0.00	13.64	43.50	-29.86
90.06012	352	V	1.02	5.42	7.81	0.73	0.00	13.96	43.50	-29.54

Table 5. Radiated Emissions, Test Results

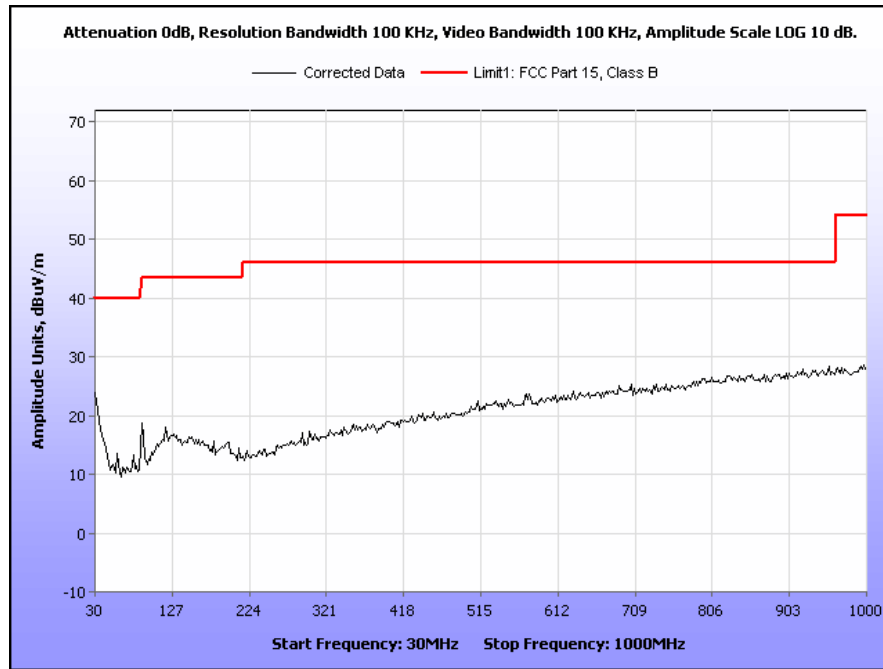

Plot 1. Radiated Emissions, Pre-Scan, 30 MHz – 1 GHz



4. Electromagnetic Compatibility Criteria for WB Devices

4.1 Antenna Requirement

Test Requirement: § 15.203: The structure and application of the EUT were analyzed to determine compliance with Section 15.203 of the Rules. Section 15.203 states that the subject device must meet at least one of the following criteria:

- a.) Antenna must be permanently attached to the unit.
- b.) Antenna must use a unique type of connector to attach to the EUT.
- c.) Unit must be professionally installed. Installer shall be responsible for verifying that the correct antenna is employed with the unit.

Test Results: The EUT complied with the requirement(s) of this section. The EUT has an integral antenna.

Test Engineer: Shawn McMillen

Test Date: 01/30/14



4.2 § 15.207(a) Conducted Emissions Limits

Test Requirement(s): § 15.207 (a): For an intentional radiator that is designed to be connected to the public utility (AC) power line, the radio frequency voltage that is conducted back onto the AC power line on any frequency or frequencies, within the band 150 kHz to 30MHz, shall not exceed the limits in the following table, as measured using a 50 μ H/50 Σ line impedance stabilization network (LISN). Compliance with the provisions of this paragraph shall be based on the measurement of the radio frequency voltage between each power line and ground at the power terminal. The lower limit applies at the boundary between the frequency ranges.

Frequency range (MHz)	§ 15.207(a), Conducted Limit (dB μ V)	
	Quasi-Peak	Average
* 0.15- 0.45	66 - 56	56 - 46
0.45 - 0.5	56	46
0.5 - 30	60	50

Table 6. Conducted Limits for Intentional Radiators from FCC Part 15 § 15.207(a)

Test Results: The EUT was not applicable with this requirement. The EUT is battery powered.



4.3 -10 dB Bandwidth Requirements

Test Requirements: § 15.250(a)(b): The -10 dB bandwidth of a device operating under the provisions of this section must be contained within the 5925 and 7250 MHz band under all conditions of operation including the effects from stepped frequency, frequency hopping or other modulation techniques that may be employed as well as the frequency stability of the transmitter over expected variations in temperature and supply voltage. The -10 dB bandwidth of the fundamental emission shall be at least 50 MHz.

Test Procedure: Emissions were measured using a horn antenna placed very close to the EUT. Due to the extremely wide nature of WB emissions, special considerations were taken to make the bandwidth measurements. The RBW was set to 3 MHz and the VBW to 3 MHz. Cable loss, pre-amp, and antenna correction factors have been programmed into spectrum analyzer.

Test Results The EUT complied with the requirement(s) of this section.

$$f_M = 6.5700 \text{ GHz}, f_L = 6.2535 \text{ GHz}, f_H = 6.8865 \text{ GHz}$$
$$\text{Therefore, -10 dB bandwidth} = f_H - f_L = 0.6331 \text{ GHz}$$

Test Engineer: Shawn McMillen

Test Dates: 01/30/14

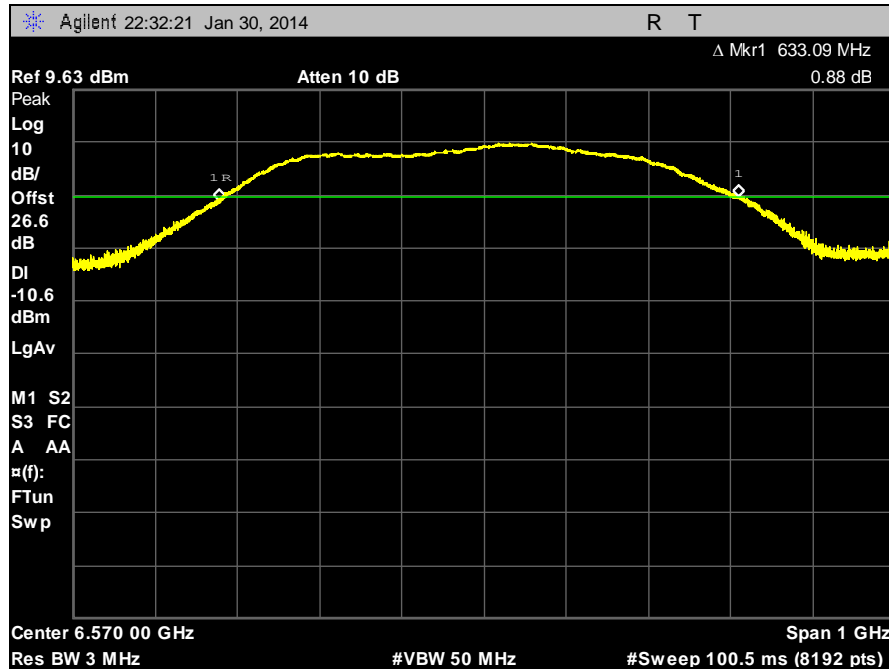

Plot 2. 10 dB Bandwidth, 1mbs

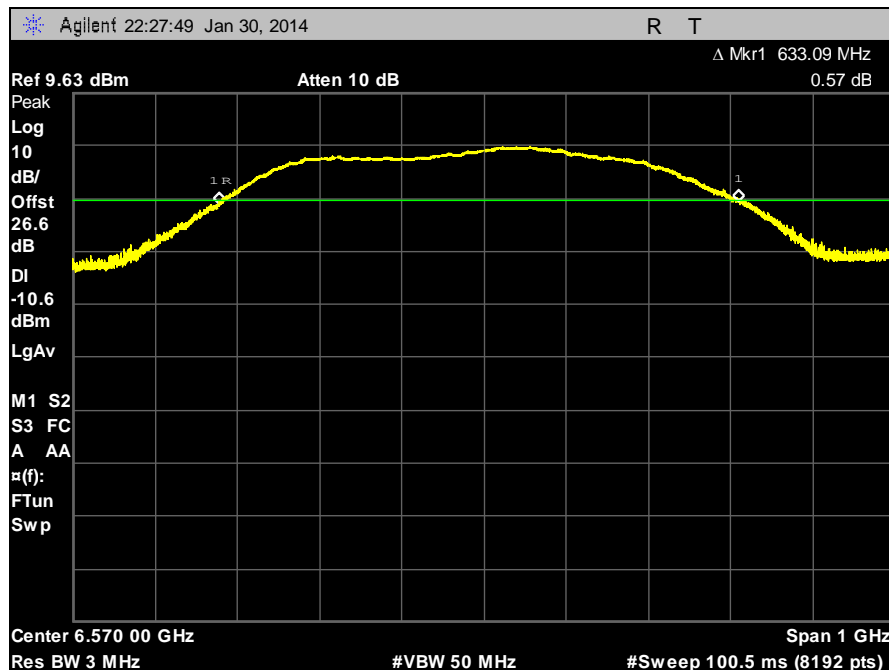

Plot 3. 10 dB Bandwidth, 2mbs

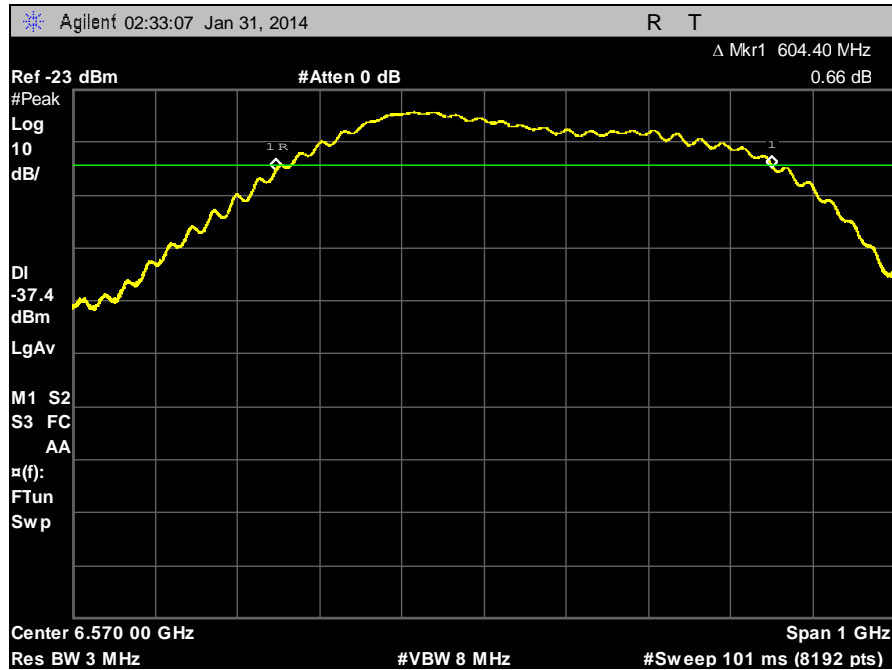

Plot 4. 10 dB Bandwidth, Ambient

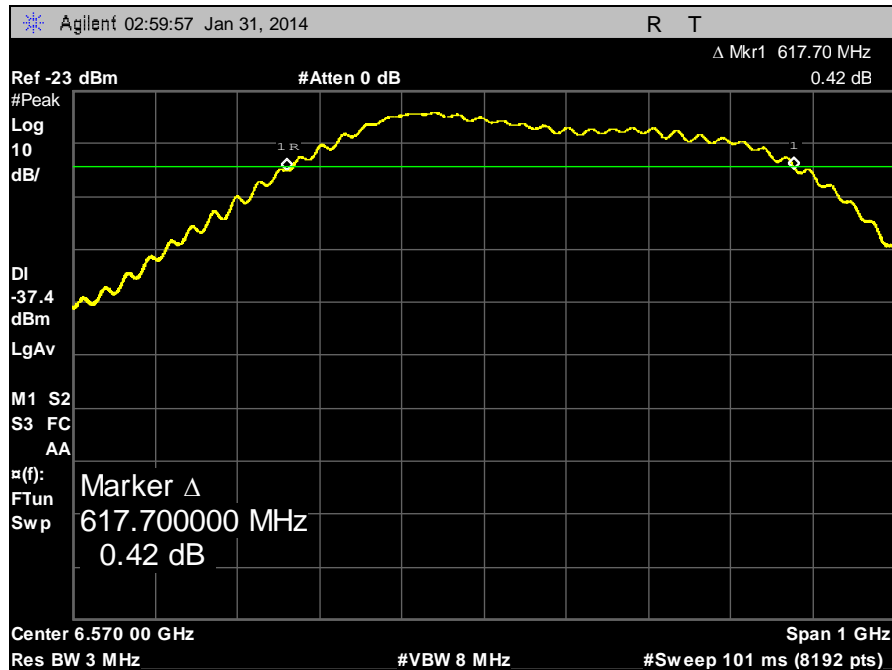

Plot 5. 10 dB Bandwidth, -40°C

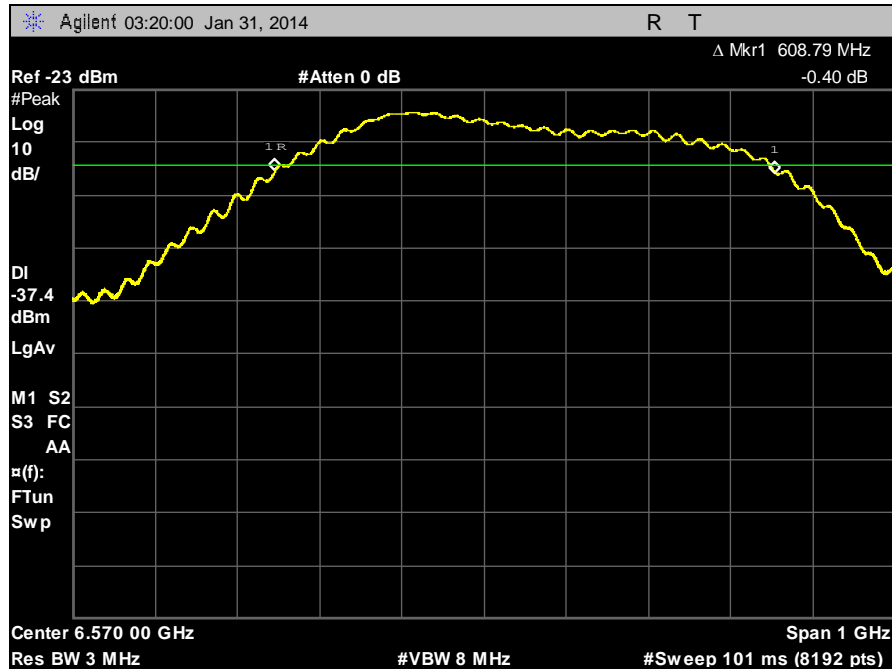

Plot 6. 10 dB Bandwidth, 70°C

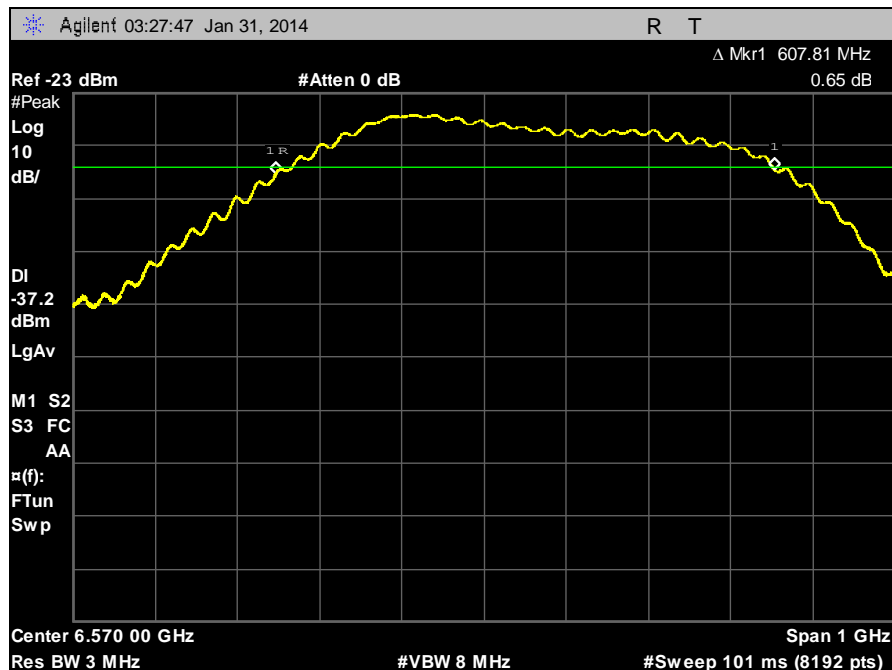

Plot 7. 10 dB Bandwidth, Normal Temperature, Normal Voltage

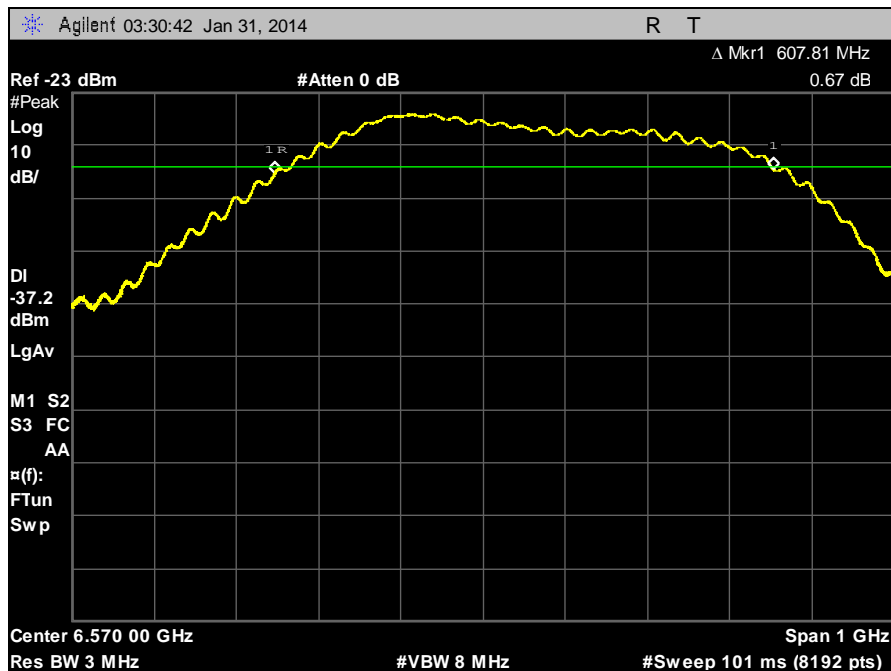

Plot 8. 10 dB Bandwidth, Normal Temperature, Low Voltage

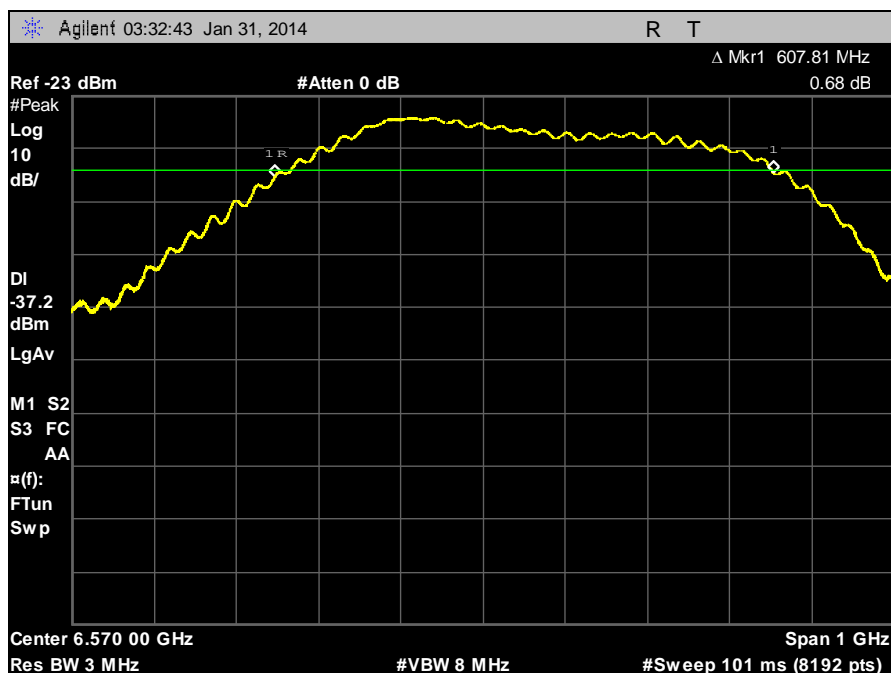

Plot 9. 10 dB Bandwidth, Normal Temperature, High Voltage



4.4 Operational Restrictions

Transmitter Requirements: §15.250(c): Technical Requirements for WB systems.

Operation under the provisions of this section is limited to WB transmitters employed in the following limitations;

- (1) Operation on board an aircraft or a satellite is prohibited.
- (2) Devices operating under this section may not be employed for the operation of toys.
- (3) Except for operation onboard a ship or a terrestrial transportation vehicle, the use of a fixed outdoor infrastructure is prohibited. A fixed infrastructure includes antennas mounted on outdoor structures, e.g., antennas mounted on the outside of a building or on a telephone pole.

Test Results: The client was notified of these requirements.

Test Engineer: Benjamin Taylor

Test Dates: 02/11/14



4.5 Radiated Emissions Above 960 MHz RMS Average

Test Requirements: § 15.250 (d)(1): Emissions from a transmitter operating under this section shall not exceed the following equivalent isotropically radiated power (EIRP) density levels:

Radiated Emissions above 960 MHz from a device operating under this section shall not exceed the average limits of Table 7 when measured using a RBW of 1 MHz.

Frequency in MHz	EIRP in dBm
960 - 1610	-75.3
1610 - 1990	-63.3
1990 - 3100	-61.3
3100 - 5925	-51.3
5925-7250	-41.3
7250-10600	-51.3
Above 10600	-61.3

Table 7. Limits for Radiated Emissions (RBW = 1MHz)

Indoor Communication, Measurement, Location Sensing and Tracking Devices	
Frequency	E.i.r.p. in a Resolution Bandwidth of 1 MHz
960-1 610 MHz	-75.3 dBm
1.61-4.75 GHz	-70.0 dBm
4.75-10.6 GHz	-41.3 dBm
Above 10.6 GHz	-51.3 dBm

Table 8. Limits for Radiated Emissions, RSS-220

Test Procedure: The EUT was placed on a pedestal inside a semi-anechoic chamber. A horn antenna with a pre-amp was placed at various distances away from the EUT and measurements made. Measurements were performed with the EUT oriented in 3 orthogonal axis and rotated 360 degrees to determine worst case orientation for maximum emissions.

Cable loss, pre-amp, distance correction, and antenna correction factors have been programmed into the spectrum analyzer. Only noise floor was observed above 18GHz.



Frequency determining parameters: The highest frequency employed in §15.33 to determine the frequency range over which radiated emissions are made were based on the center frequency, f_c , unless a higher frequency was generated within the WB device. For measuring emission levels, the spectrum were investigated from the lowest frequency generated in the WB, without going below 9 kHz, up to the frequency range shown in Section 15.33(a) of the CFR 47 or up to $f_c + 3/(\text{pulse width in seconds})$, whichever was higher. There is no requirement to measure emissions beyond 40 GHz provided f_c was less than 10 GHz; beyond 100 GHz if f_c was at or above 10 GHz and below 30 GHz; or beyond 200 GHz if f_c was at or above 30 GHz.

Test Results: The EUT complied with the requirement(s) of this section. Plots are provided for emissions between 960 – 18000 MHz. The plots display the EIRP measurement against the appropriate limit line. Emissions were also investigated from 18 GHz to 40 GHz. Only noise floor was detected at these frequencies.

Test Engineer: Shawn McMillen and Benjamin Taylor

Test Dates: 01/30/14 and 02/11/14

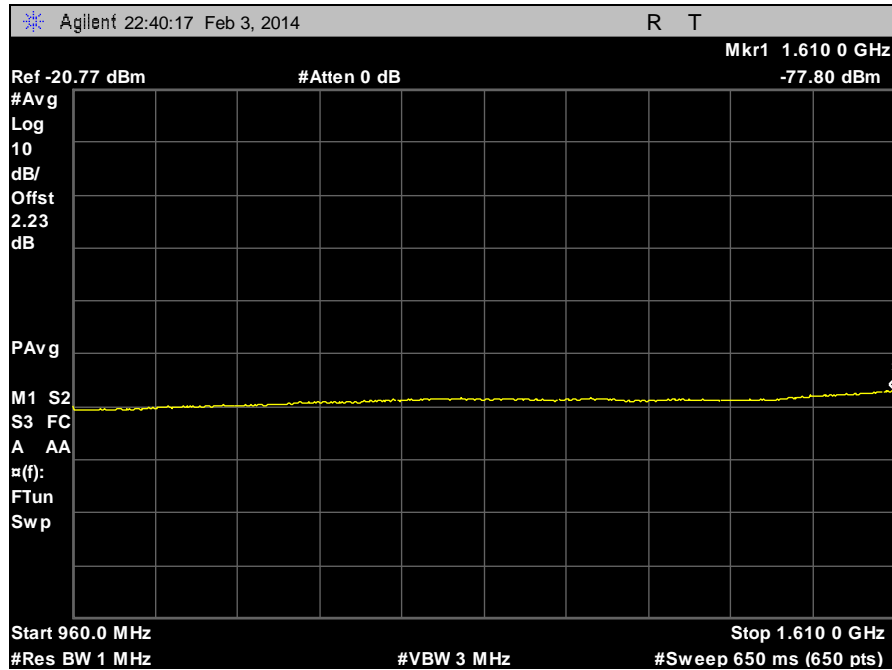

Plot 10. Radiated Emissions Above 960 MHz, 960 MHz – 1610 MHz, Average, 1mbs

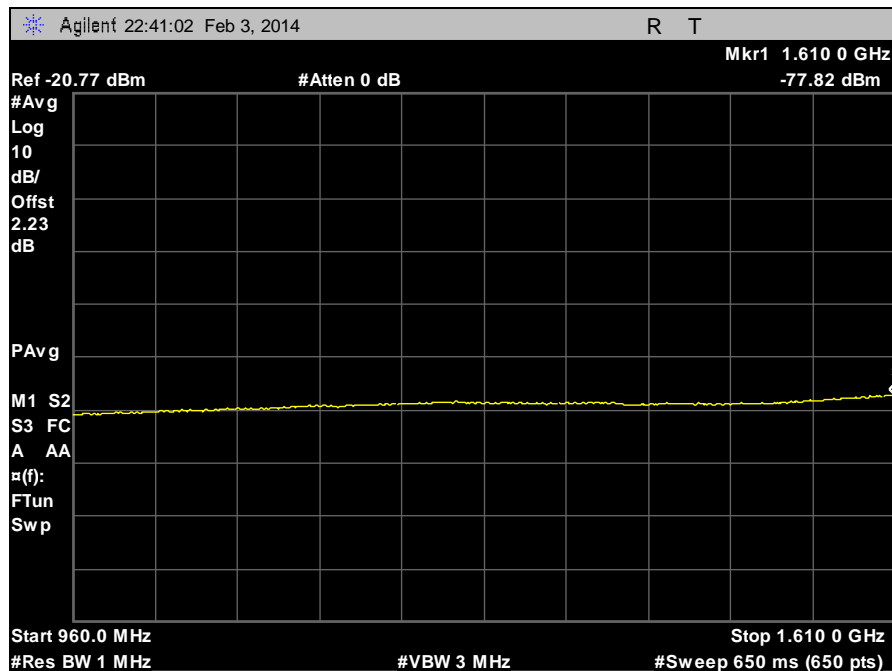

Plot 11. Radiated Emissions Above 960 MHz, 960 MHz – 1610 MHz, Average, 2mbs

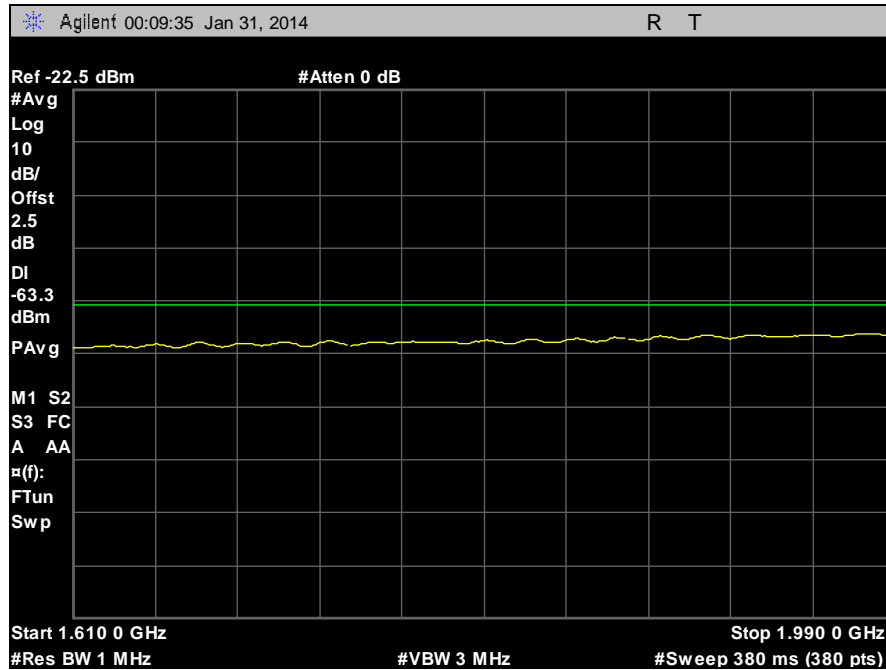

Plot 12. Radiated Emissions Above 960 MHz, 1610 MHz – 1990 MHz, Average, 1mbs

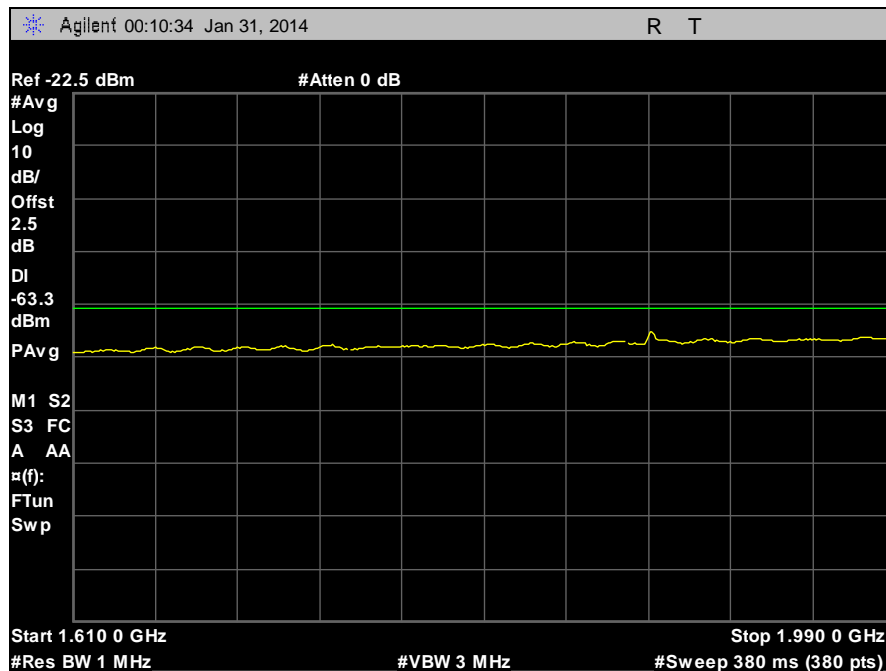

Plot 13. Radiated Emissions Above 960 MHz, 1610 MHz – 1990 MHz, Average, 2mbs

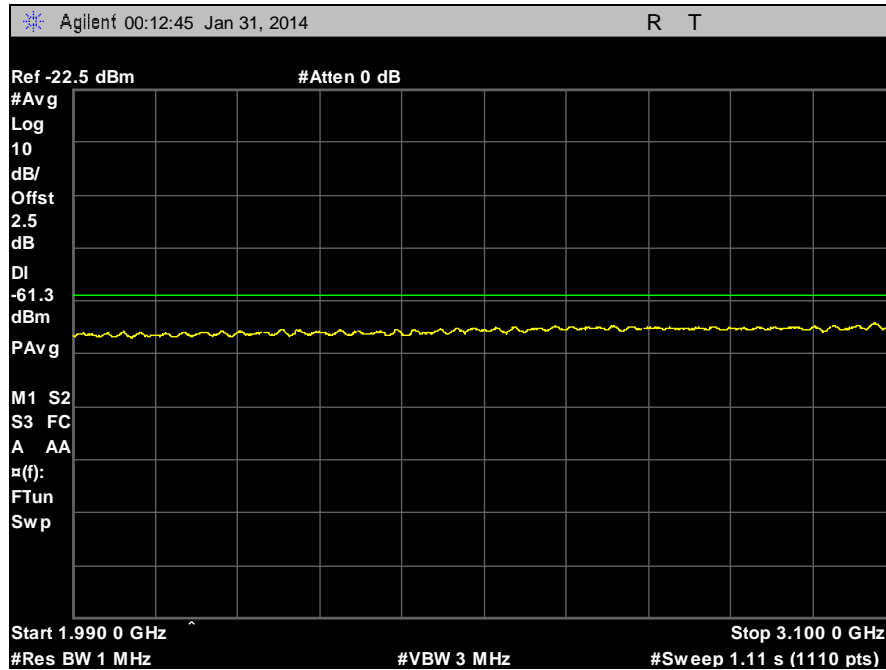

Plot 14. Radiated Emissions Above 960 MHz, 1990 MHz – 3100 MHz, Average, 1mbs

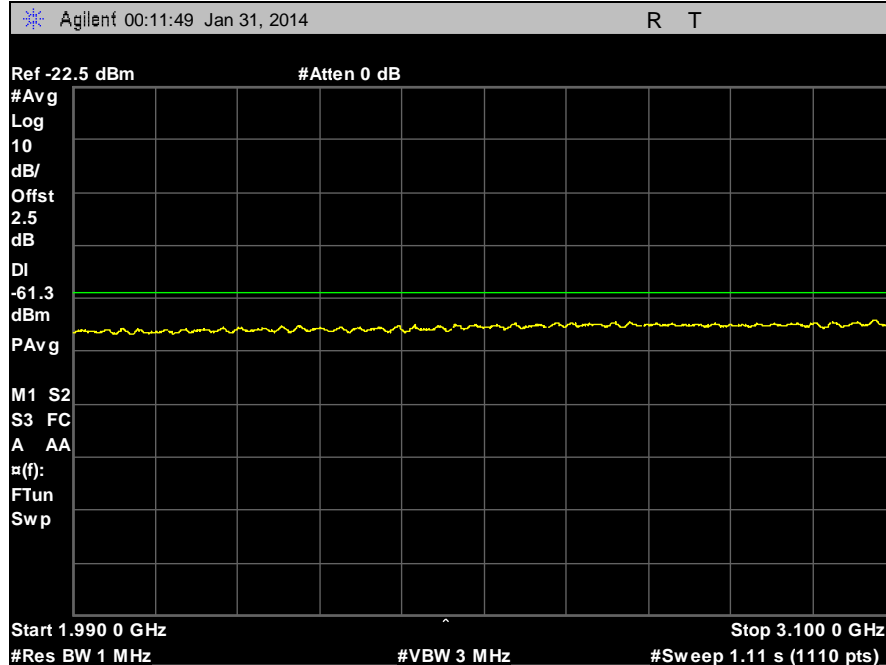

Plot 15. Radiated Emissions Above 960 MHz, 1990 MHz – 3100 MHz, Average, 2mbs

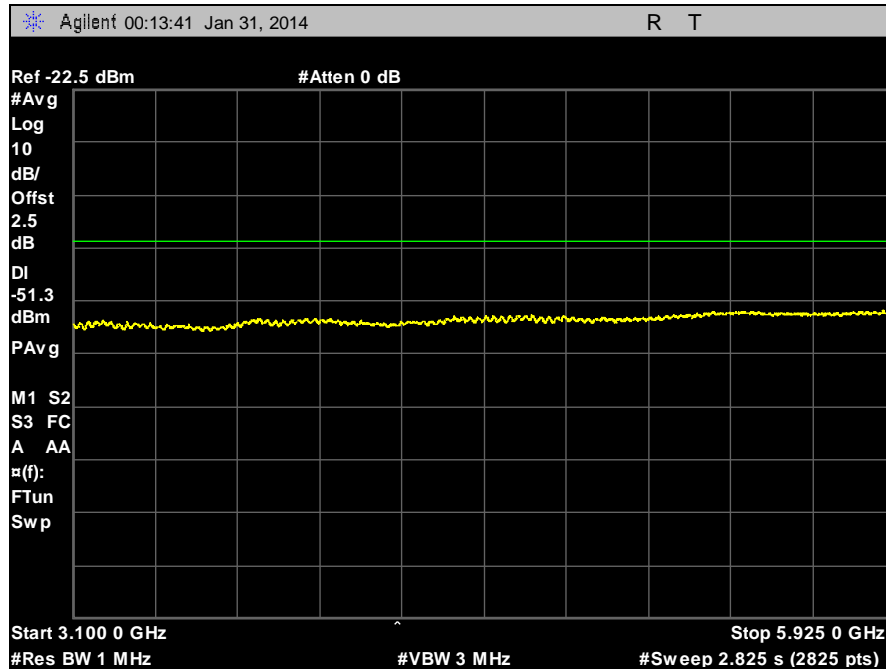

Plot 16. Radiated Emissions Above 960 MHz, 3100 MHz – 5925 MHz, Average, 1mbs

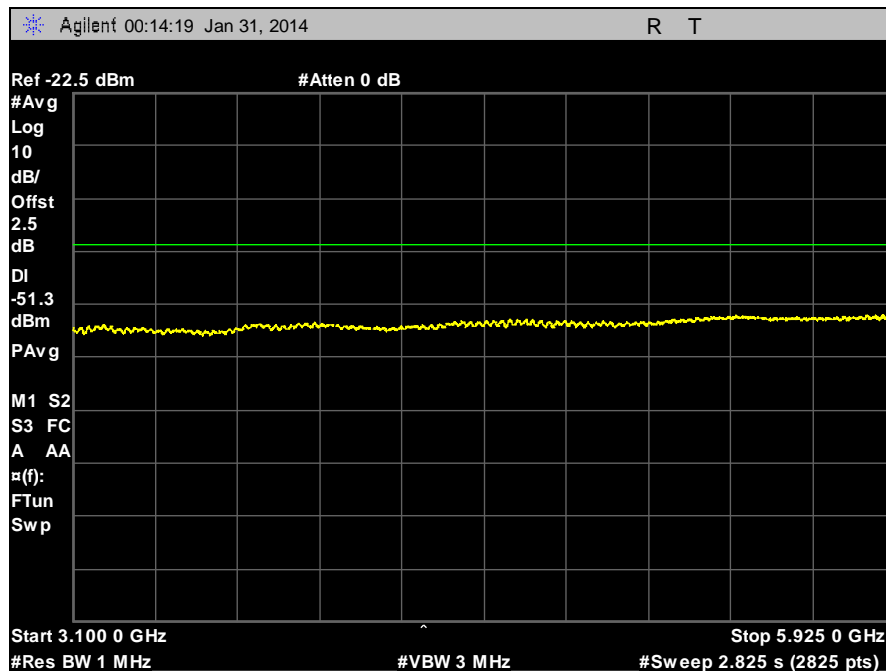

Plot 17. Radiated Emissions Above 960 MHz, 3100 MHz – 5925 MHz, Average, 2mbs

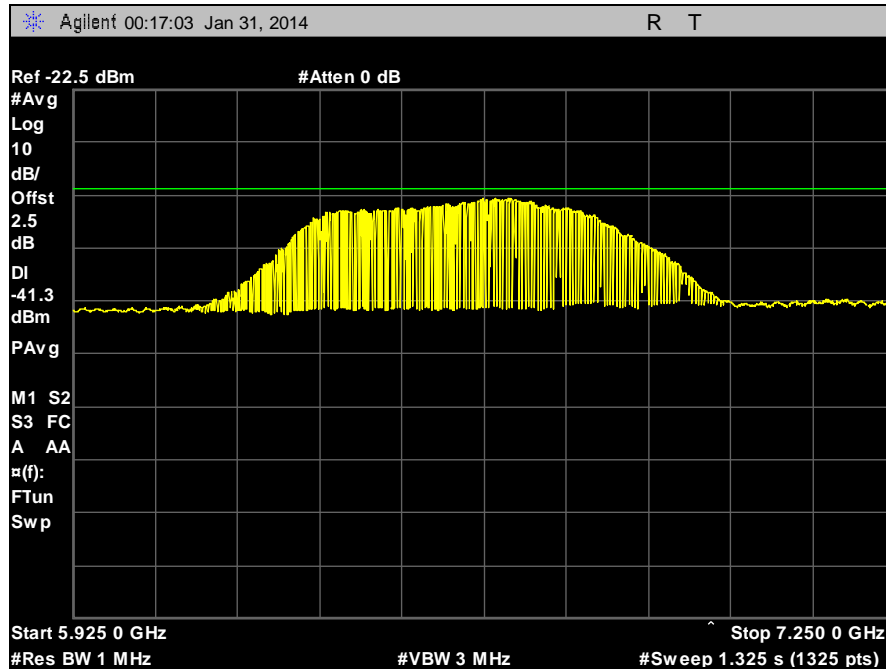

Plot 18. Radiated Emissions Above 960 MHz, 5925 MHz – 7250 MHz, Average, 1mbs

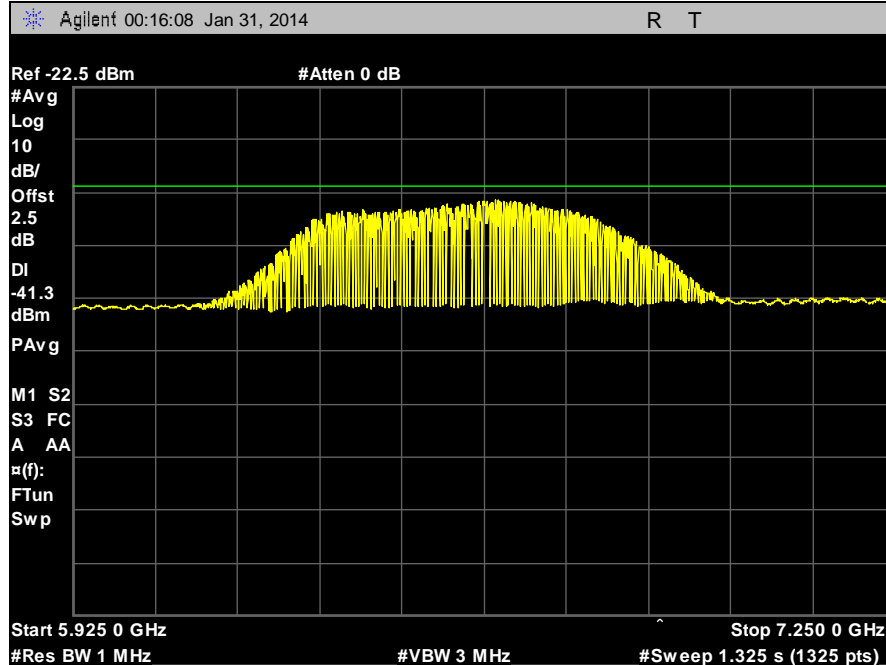

Plot 19. Radiated Emissions Above 960 MHz, 5925 MHz – 7250 MHz, Average, 2mbs

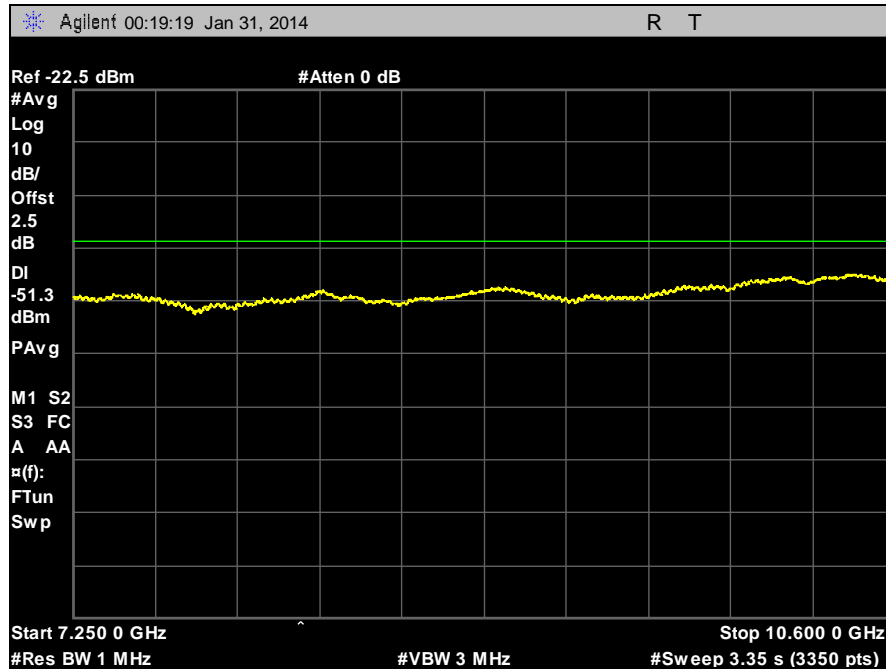

Plot 20. Radiated Emissions Above 960 MHz, 7250 MHz – 10600 MHz, Average, 1mbs

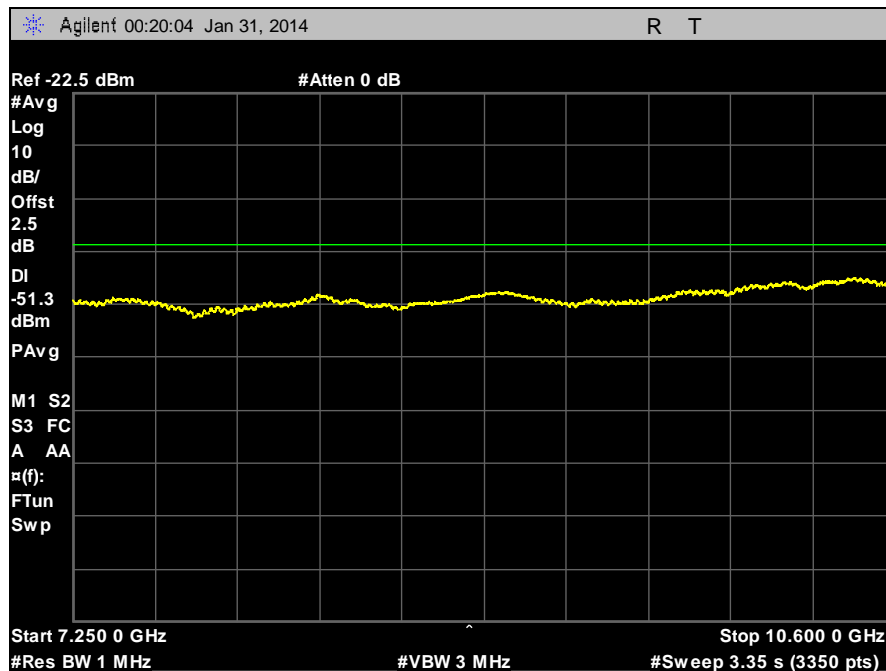

Plot 21. Radiated Emissions Above 960 MHz, 7250 MHz – 10600 MHz, Average, 2mbs

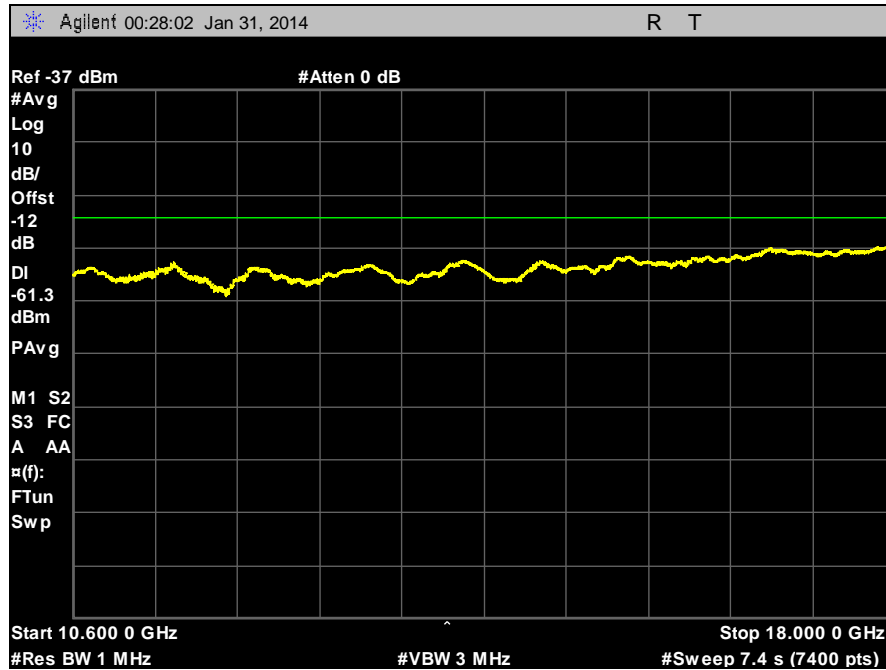

Plot 22. Radiated Emissions Above 960 MHz, 10600 MHz – 18000 MHz, Average, 1mbs

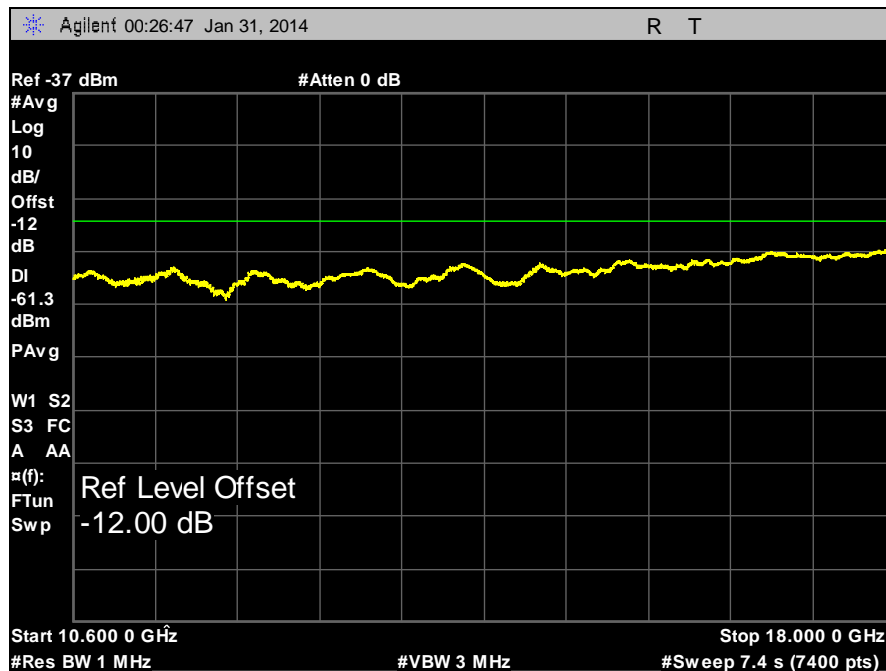

Plot 23. Radiated Emissions Above 960 MHz, 10600 MHz – 18000 MHz, Average, 2mbs



4.6 GPS emissions

Test Requirements: §15.250(d)(2): In addition to the radiated emission limits specified in the table in paragraph (d)(1) of this section, transmitters operating under the provisions of this section shall not exceed the following RMS average limits when measured using a resolution bandwidth of no less than 1 kHz:

Frequency in MHz	EIRP in dBm
1164 - 1240	-85.3
1559 - 1610	-85.3

Table 9. Limits for Radiated Emissions (RBW \geq 1kHz)

Test Results: The EUT was compliant with the requirement(s) of this section. Due to equipment limitations, conducted measurements were used in lieu of radiated measurements, with the resulting traces corrected to show the EIRP of the emissions. Any emissions were compared to the limits of Table 9.

Test Engineer: Shawn McMillen

Test Date: 01/30/14

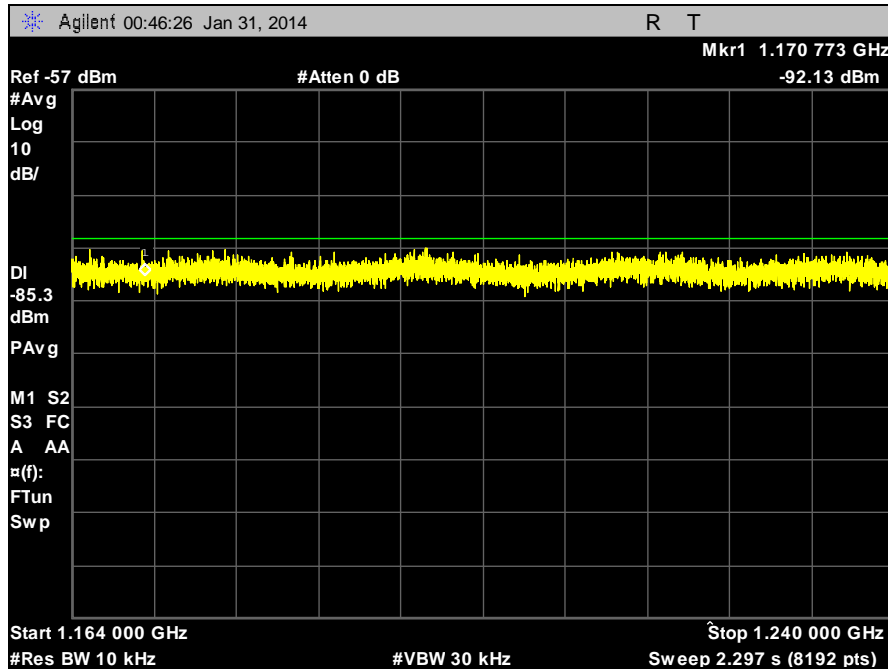

Plot 24. GPS Bands, 1164 MHz – 1240 MHz, Average, 1mbs

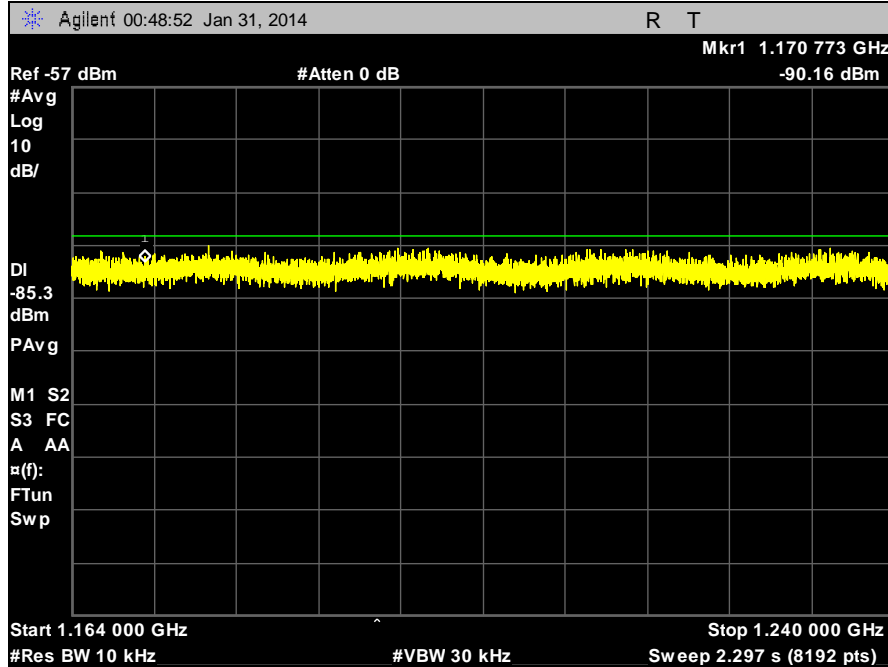

Plot 25. GPS Bands, 1164 MHz – 1240 MHz, Average, 2mbs

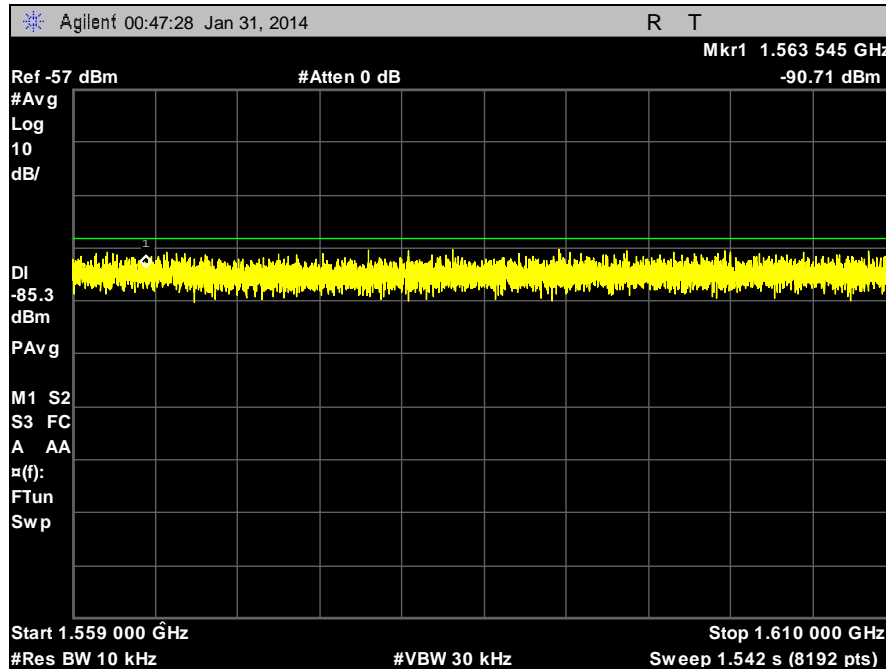

Plot 26. GPS Bands, 1559 MHz – 1610 MHz, Average, 1mbs

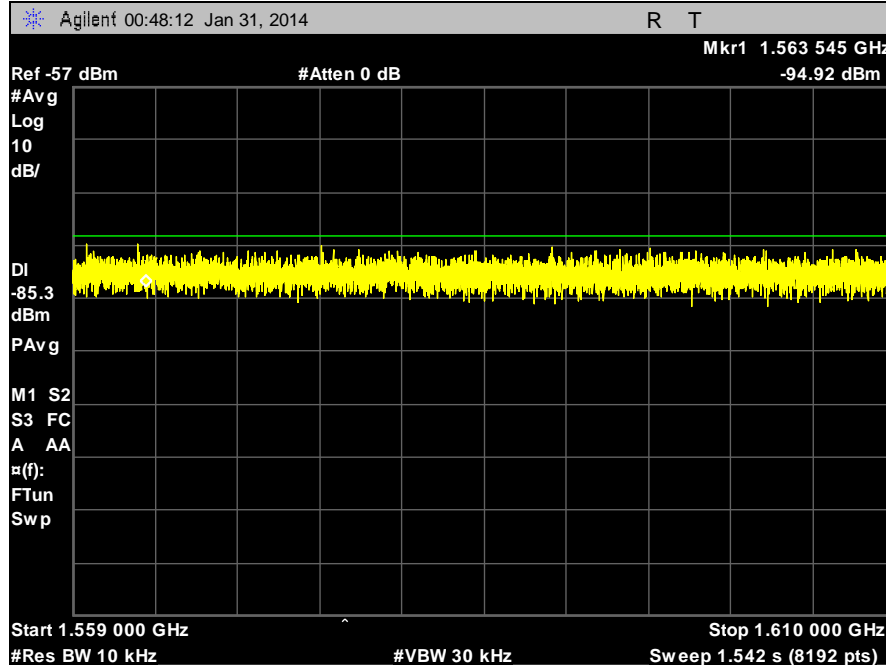

Plot 27. GPS Bands, 1559 MHz – 1610 MHz, Average, 2mbs



4.7 Peak Radiated Emissions Requirements

Test Requirements: §15.250(d)(3): There is a limit on the peak level of the emissions contained within a 50 MHz bandwidth centered on the frequency at which the highest radiated emission occurs and this 50 MHz bandwidth must be contained within the 5925–7250 MHz band. The peak EIRP limit is $20 \log (\text{RBW}/50)$ dBm where RBW is the resolution bandwidth in megahertz that is employed by the measurement instrument. RBW shall not be lower than 1 MHz or greater than 50 MHz. The video bandwidth of the measurement instrument shall not be less than RBW. If RBW is greater than 3 MHz, the application for certification filed with the Commission shall contain a detailed description of the test procedure, calibration of the test setup, and the instrumentation employed in the testing.

Calculation of Limit: Pursuant to §15.250(d)(3), the data was corrected for bandwidth correction $20 \log (50/3) = -24.4\text{dB}$.
 $\text{EIRP} = E (\text{dBuV/m}) + 20 \log D - 104.8 + 24.4$.

Test Results: The EUT was found to comply with the requirements of §15.250(d)(3). Measured with 3MHz RBW. $\text{Limit} = 20 \log (3\text{MHz}/50\text{MHz}) = -24.4\text{dBm EIRP}$.

The offset on the spectrum analyzer was set to -26.6dB which included the -24.4 correct to 50MHz RBW from the 3MHz that was used as well as an additional -2.2dB from the conversion to dBm from dBuV. 104.8-107

Test Engineer: Shawn McMillen

Test Date: 01/30/14

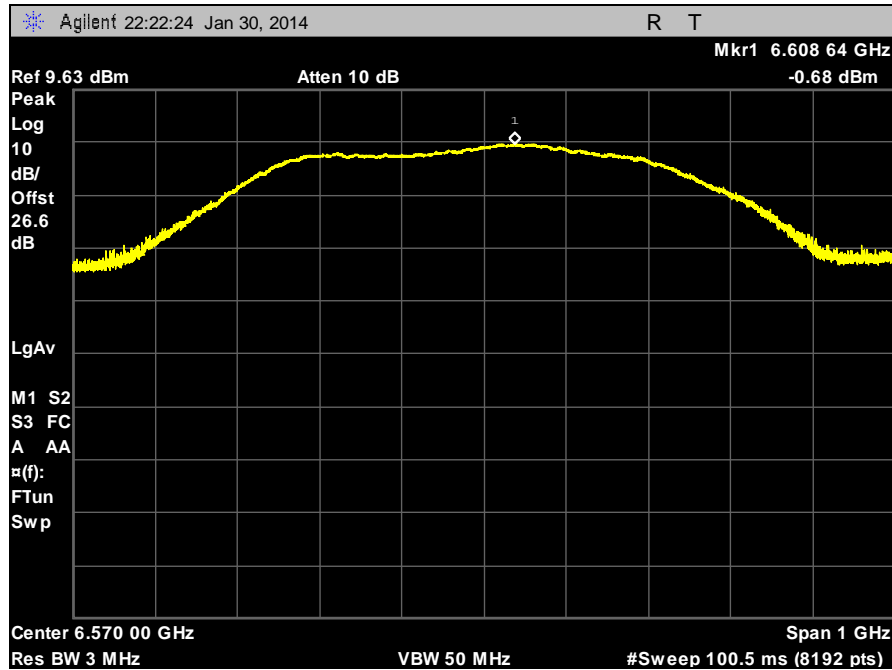

Plot 28. Peak Emissions, 1mbs

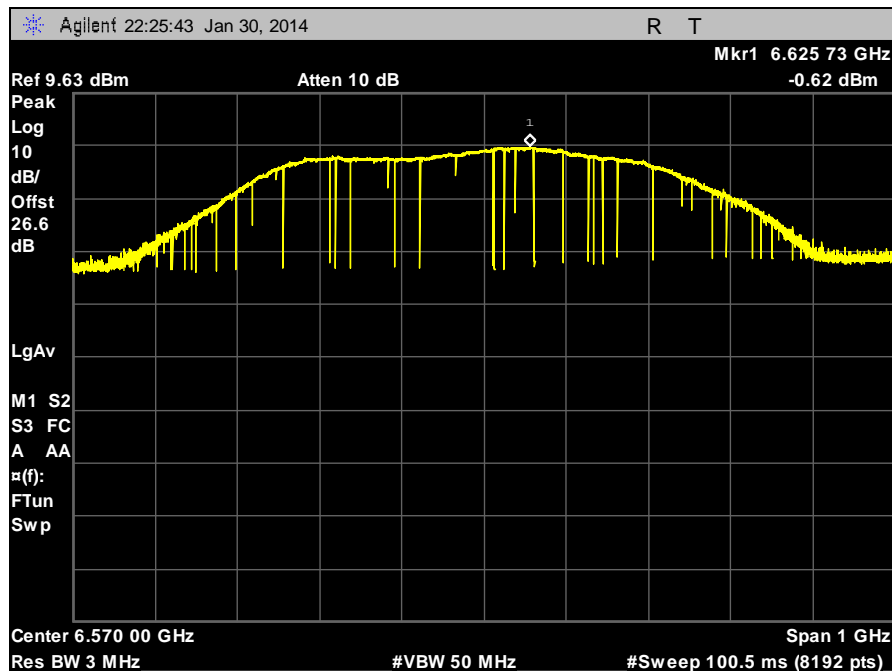

Plot 29. Peak Emissions, 2mbs



4.8 15.250(d)(4) Radiated emissions below 960 MHz

Test Requirements: § 15.250 (d)(4): Radiated emissions at or below 960 MHz shall not exceed the emission levels in § 15.209.

§ 15.209 (a) Except as provided elsewhere in this subpart, the emissions from an intentional radiator shall not exceed the field strength levels specified in Table 10.

Frequency (MHz)	§15.209(a), Radiated Emission Limits (dB:V) @ 3m
30 - 88	40.00*
88 - 216	43.50*
216 - 960	46.00*
Above 960	54.00

* -- Except perimeter protection systems operating under paragraph (g), fundamental emissions from intentional radiators operating under this Section shall not be located in the frequency bands 54-72 MHz, 76-88 MHz, 174-216 MHz or 470-806 MHz. However, operation within these frequency bands is permitted under other sections of this Subpart.

Table 10. Radiated Emissions Limits Calculated from FCC Part 15, § 15.209 (a)

Test Procedure: The EUT was placed on a 0.8m pedestal inside a semi-anechoic chamber. A measurement antenna was placed 3 m away from the EUT. The EUT was rotated about all three orthogonal axis while a pre-scan was performed. The antenna was varied between 1 m and 4 m, in both horizontal and vertical polarities.

No further measurements were made. All peak data on the pre-scan was below the limit line minimally by 20 dB.

Test Results: The EUT complied with the requirement(s) of this section.

Test Engineer: Benjamin Taylor

Test Date: 02/11/14

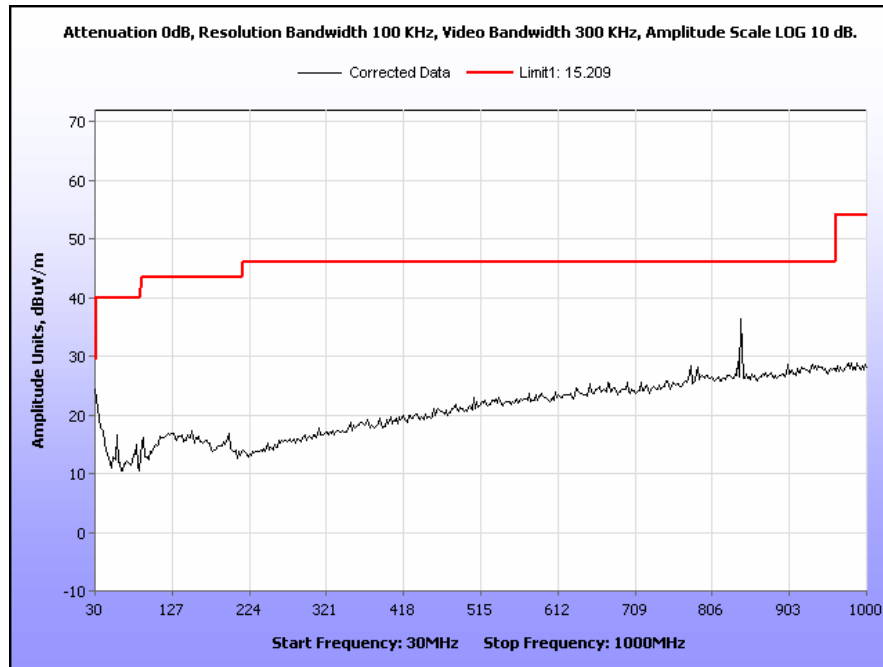

Plot 30. Radiated Emissions Below 960 MHz, 30 MHz – 1 GHz



5 Test Equipment

Calibrated test equipment utilized during testing was maintained in a current state of calibration per the requirements of ISO/IEC 17025:2005.

MET ASSET #	EQUIPMENT	MANUFACTURER	MODEL	LAST CAL DATE	CAL DUE DATE
1T4149	HIGH-FREQUENCY ANECHOIC CHAMBER	RAY-PROOF	81	SEE NOTE	
1T4300	SEMI-ANECHOIC CHAMBER #1 (FCC)	EMC TEST SYSTEMS	NONE	07/24/2012	07/24/2015
1T4751	ANTENNA - BILOG	SUNOL SCIENCES	JB6	01/08/2013	07/08/2014
1T4771	PSA SPECTRUM ANALYZER	AGILENT TECHNOLOGIES	E4446A	02/15/2013	08/15/2014
1T4442	PRE-AMPLIFIER, MICROWAVE	MITEQ	AFS42-01001800-30-10P	SEE NOTE	
1T4505	TEMPERATURE CHAMBER	TEST EQUITY	115	01/05/2014	01/05/2015
1T4483	ANTENNA; HORN	ETS-LINDGREN	3117	08/06/2012	02/06/2014

Note: Functionally verified test equipment is verified using calibrated instrumentation at the time of testing.



6 Compliance Information

6.1 Certification Information

The following is extracted from Title 47 of the Code of Federal Regulations, Part 2, Subpart I — Marketing of Radio frequency devices:

§ 2.801 Radio-frequency device defined.

As used in this part, a radio-frequency device is any device which in its operation is capable of Emitting radio-frequency energy by radiation, conduction, or other means. Radio- frequency devices include, but are not limited to:

- (a) The various types of radio communication transmitting devices described throughout this chapter.
- (b) The incidental, unintentional and intentional radiators defined in Part 15 of this chapter.*
- (c) The industrial, scientific, and medical equipment described in Part 18 of this chapter.
- (d) Any part or component thereof which in use emits radio-frequency energy by radiation, conduction, or other means.

§ 2.803 Marketing of radio frequency devices prior to equipment authorization.

- (a) Except as provided elsewhere in this chapter, no person shall sell or lease, or offer for sale or lease (including advertising for sale or lease), or import, ship or distribute for the purpose of selling or leasing or offering for sale or lease, any radio frequency device unless:
 - (1) In the case of a device subject to certification, such device has been authorized by the Commission in accordance with the rules in this chapter and is properly identified and labeled as required by §2.925 and other relevant sections in this chapter; or
 - (2) In the case of a device that is not required to have a grant of equipment authorization issued by the Commission, but which must comply with the specified technical standards prior to use, such device also complies with all applicable administrative (including verification of the equipment or authorization under a Declaration of Conformity, where required), technical, labeling and identification requirements specified in this chapter.
- (d) Notwithstanding the provisions of paragraph (a) of this section, the offer for sale solely to business, commercial, industrial, scientific or medical users (but not an offer for sale to other parties or to end users located in a residential environment) of a radio frequency device that is in the conceptual, developmental, design or pre-production stage is permitted prior to equipment authorization or, for devices not subject to the equipment authorization requirements, prior to a determination of compliance with the applicable technical requirements *provided* that the prospective buyer is advised in writing at the time of the offer for sale that the equipment is subject to the FCC rules and that the equipment will comply with the appropriate rules before delivery to the buyer or to centers of distribution.



- (e)(1) Notwithstanding the provisions of paragraph (a) of this section, prior to equipment authorization or determination of compliance with the applicable technical requirements any radio frequency device may be operated, but not marketed, for the following purposes and under the following conditions:
- (i) *Compliance testing;*
 - (ii) Demonstrations at a trade show provided the notice contained in paragraph (c) of this section is displayed in a conspicuous location on, or immediately adjacent to, the device;
 - (iii) Demonstrations at an exhibition conducted at a business, commercial, industrial, scientific or medical location, but excluding locations in a residential environment, provided the notice contained in paragraphs (c) or (d) of this section, as appropriate, is displayed in a conspicuous location on, or immediately adjacent to, the device;
 - (iv) Evaluation of product performance and determination of customer acceptability, provided such operation takes place at the manufacturer's facilities during developmental, design or pre-production states; or
 - (v) Evaluation of product performance and determination of customer acceptability where customer acceptability of a radio frequency device cannot be determined at the manufacturer's facilities because of size or unique capability of the device, provided the device is operated at a business, commercial, industrial, scientific or medical user's site, but not at a residential site, during the development, design or pre-production stages.
- (e)(2) For the purpose of paragraphs (e)(1)(iv) and (e)(1)(v) of this section, the term *manufacturer's facilities* includes the facilities of the party responsible for compliance with the regulations and the manufacturer's premises, as well as the facilities of other entities working under the authorization of the responsible party in connection with the development and manufacture, but not the marketing, of the equipment.
- (f) For radio frequency devices subject to verification and sold solely to business, commercial, industrial, scientific and medical users (excluding products sold to other parties or for operation in a residential environment), parties responsible for verification of the devices shall have the option of ensuring compliance with the applicable technical specifications of this chapter at each end user's location after installation, provided that the purchase or lease agreement includes a proviso that such a determination of compliance be made and is the responsibility of the party responsible for verification of the equipment.



The following is extracted from Title 47 of the Code of Federal Regulations, Part 2, and Subpart J— Equipment Authorization Procedures:

§ 2.901 Basis and Purpose

- (a) In order to carry out its responsibilities under the Communications Act and the various treaties and international regulations, and in order to promote efficient use of the radio spectrum, the Commission has developed technical standards for radio frequency equipment and parts or components thereof. The technical standards applicable to individual types of equipment are found in that part of the rules governing the service wherein the equipment is to be operated.¹ *In addition to the technical standards provided, the rules governing the service may require that such equipment be verified by the manufacturer or importer*, be authorized under a Declaration of Conformity, or receive an equipment authorization from the Commission by one of the following procedures: certification or registration.
- (b) The following sections describe the verification procedure, the procedure for a Declaration of Conformity, and the procedures to be followed in obtaining certification from the Commission and the conditions attendant to such a grant.

§ 2.907 Certification

- (a) Certification is an equipment authorization issued by the Commission, based on representation and test data submitted by the applicant.
- (b) Certification attaches to all units subsequently marketed by the grantee which are identical (see Section 2.908) to the sample tested except for permissive changes or other variations authorized by the Commission pursuant to Section 2.1043.

¹ In this case, the equipment is subject to the rules of Part 15. More specifically, the equipment falls under Subpart B (of Part 15), which deals with unintentional radiators.



§ 2.948 Description of measurement facilities.

- (a) Each party making measurements of equipment that is subject to an equipment authorization under Part 15 or Part 18 of this chapter, regardless of whether the measurements are filed with the Commission or kept on file by the party responsible for compliance of equipment marketed within the U.S. or its possessions, shall compile a description of the measurement facilities employed.
- (1) If the measured equipment is subject to the verification procedure, the description of the measurement facilities shall be retained by the party responsible for verification of the equipment.
- (i) *If the equipment is verified through measurements performed by an independent laboratory, it is acceptable for the party responsible for verification of the equipment to rely upon the description of the measurement facilities retained by or placed on file with the Commission by that laboratory. In this situation, the party responsible for the verification of the equipment is not required to retain a duplicate copy of the description of the measurement facilities.*
- (ii) If the equipment is verified based on measurements performed at the installation site of the equipment, no specific site calibration data is required. It is acceptable to retain the description of the measurement facilities at the site at which the measurements were performed.
- (2) If the equipment is to be authorized by the Commission under the certification procedure, the description of the measurement facilities shall be filed with the Commission's Laboratory in Columbia, Maryland. The data describing the measurement facilities need only be filed once but must be updated as changes are made to the measurement facilities or as otherwise described in this section. At least every three years, the organization responsible for filing the data with the Commission shall certify that the data on file is current.