

SPRF2413A-001

2.4GHz 32CH 2way RF SoC USB Desktop Receiver

Preliminary

AUG. 22, 2009

Version 0.92

2.4GHZ 32CH 2WAY RF SOC USB DESKTOP RECEIVER

1. FEATURES

1.1. Common Features

- Supports USB interface both device of Keyboard and mouse or mouse device only by strap / AP-Software option
- Keyboard event support:
 - Caps Lock status LED
 - Scroll Lock status LED
 - Number Lock status LED
- Connect (bind) button for easy devices mating
- For use in either in vertical position on metallic desk or in horizontal position on non-metallic desk
- Supports Mouse 2 tilt buttons (left / right) decode for horizontal scrolling
- High report rate: 125 rps for USB protocol response
- SunplusIT software driver available for Tilt-button enable
- USB Multimedia/Internet hot-keys available for 2 customized keys
- Built-in EEPROM (128 Bytes) used for Channel; ID and RF test mode memorizes
- Built-in 3.3 Volt regulator for USB and internal operation
- Operating Frequency : 6MHz.

1.2. Power Management Features

- Support RF power Down mode while entrance USB suspend mode.
- Remote wake-up support:
 - Keyboard or mouse activity.

1.3. 2.4GHz RF Features

- 2.4GHz GFSK RF transceiver
- 32 channels hopping with 2 group form 2.405GHz ~ 2.476GHz. (see section 6)
- Sensitivity up to -93 dBm (@ 250kbps)
- Output power up to 0 dBm
- Low-noise amplifier, power amplifier, modem and data slicer/recovery on chip
- High speed RF link data rate Max. 1M bit/s
- 24 bits ID number (16777216 combinations): allows the receiver to identify its mouse
- 1 connect (bind) button for RF link sync

1.4. USB Features

- The Endpoint 0 is used for control pipe and Endpoint 1, & 2 for the interrupt (data transfer) as specified in the USB spec
- The Endpoint 1& 2 polling rate up to 8ms (125Hz).
- Declares itself as a composite device : keyboard, mouse, multimedia keys and power keys
- Supports report protocol or boot protocol both keyboard and mouse
- Supports RF link and data transfer status with a LED blinking

1.5. Package

- 40Pin QFN 6 X 6 mm package available.
- Small Form Factor for tiny size USB Dongle
- Operation temperature range from -0 °C to +70 °C

2. BLOCK DIAGRAM

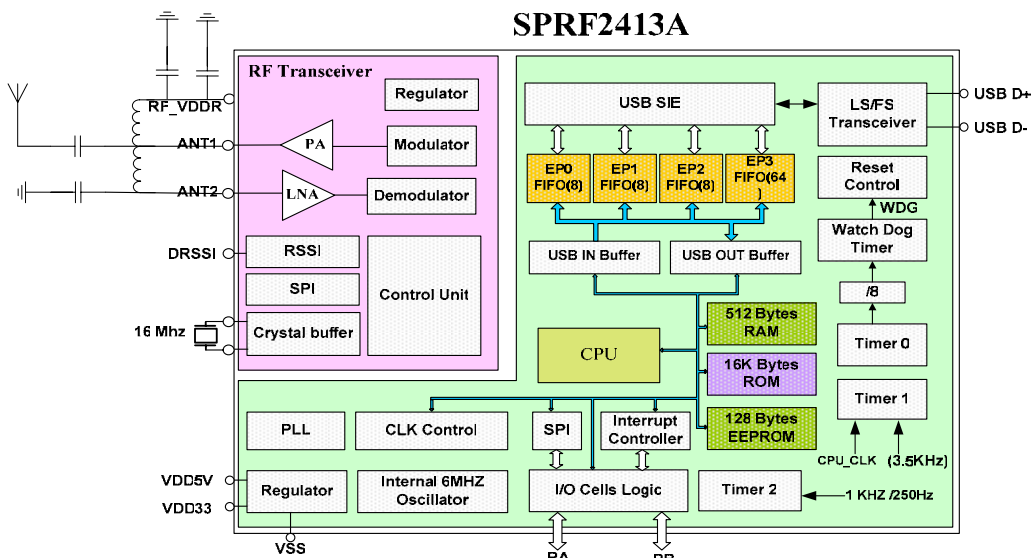

3. SIGNAL DESCRIPTIONS

3.1. PIN Descriptions

IC Name	PIN No.	I/O	Function Description
GND	1	P	System ground pin
PB0	2	B	General Purpose I/O Port_B0 for NUMLOCK LED output
PB1	3	I	General Purpose I/O Port_B1 for RF_MISO (Master In / Slave Out)
PB2	4	B	General Purpose I/O Port_B2 for RF_SCLK (SPI clock)
PB3	5	O	General Purpose I/O Port_B3 for RF_MOSI (Master Out / Slave in)
NC	6	-	Not Connect
PB4	7	B	General Purpose I/O Port_B4 for CAPLOCK LED output
PB5	8	B	General Purpose I/O Port_B5 for SCRLOCK LED output
RF_TTRDY	9	I	RF digital input. Assert to set the RF Band to Active Mode.
RF_TRLCK	10	B	RF digital input at Burst Mode and digital output at Direct Mode. Clock signal of the SPI/FIFO interface.
RF_TRSDA	11	B	RF digital input/output. Data signal of the SPI/FIFO interface.
RF_SPIEN	12	I	Enable RF signal of the SPI interface.
RF_VCCO	13	P	RF VCO power pin. +3.3V
RF_GNDD	14	P	RF digital ground
RF_VDDD	15	P	RF digital decoupling power pin.
RF_XOUT	16	O	16MHz Crystal output
RF_XIN	17	I	16MHz Crystal input
RF_PSB	18	I	RF digital input. Assert to force RF band to enter Power-Saving Mode or Power-Down Mode, depended on the state of TTRDY.
RF_GDVCO	19	P	RF VCO ground.
RF_PWVCO	20		RF VCO power
RF_VDDR	21	P	RF decoupling power pin.
RF_ANT1	22	B	RF frame ground RF signal pin, Antenna I/F
RF_ANT2	23	B	RF signal pin, Antenna I/F
RF_GND	24	P	RF ground
RF_VCC	25	P	RF power pin. +3.3V
RF_GNDIF	26	P	RF Analog IF ground
RF_TRINT	27	O	RF digital output. Asserted when transmitting or receiving is accomplished.
RF_DRSSI	28	O	RF Analog output. Analog RSSI output pin.
RF_TEST1	29	-	Reserved Pin for RF internal test
RF_TEST2	30	-	Reserved Pin for RF internal test
PA3	31	B	General Purpose I/O Port_A3 for Binding button
PA2	32	B	General Purpose I/O Port_A2 for 1. RF_PSB digital data out 2. Device (Receiver) type strap option input while power on reset duration. > Pull down = Mouse only ; > Not connect = depended on EEPROM; 0= Mouse only ; 1= Keyboard + Mouse default Desktop (Keyboard + Mouse)
PA1	33	B	General Purpose I/O Port_A1 for RF_SPIEN pin output control
PA0	34	B	General Purpose I/O Port_A0 for RF_TTRDY output control
PC0	35	B	General Purpose I/O Port_C0 for RF_TRINT input
DM	36	B	USB – Data
DP	37	B	USB + Data
VC	38	O	3.3 Volt Regulator Output
VDD	39	P	5V Power
XO	40	O	Crystal Output

3.2. PIN Assignment

SPRF2413A-001 QFN40

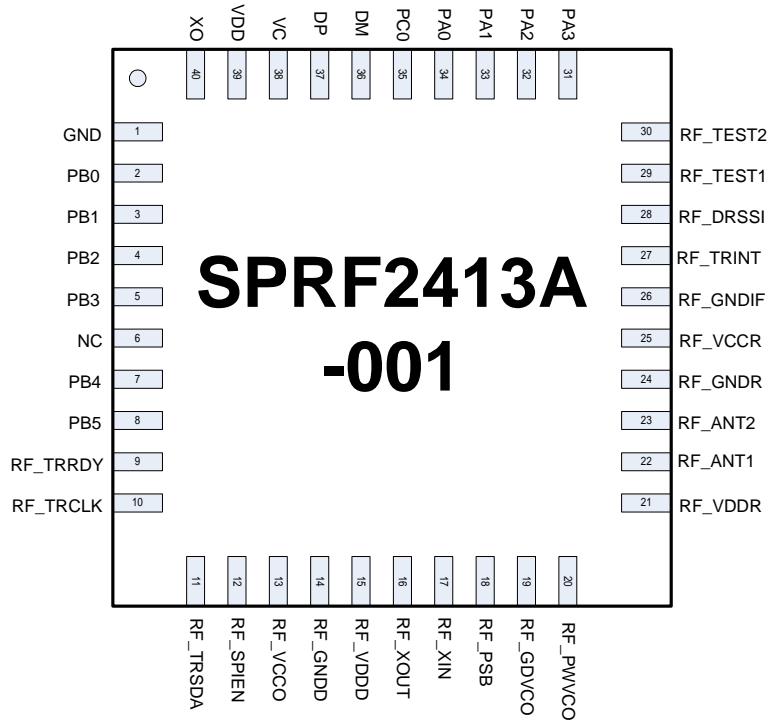

4. Application Block Diagram

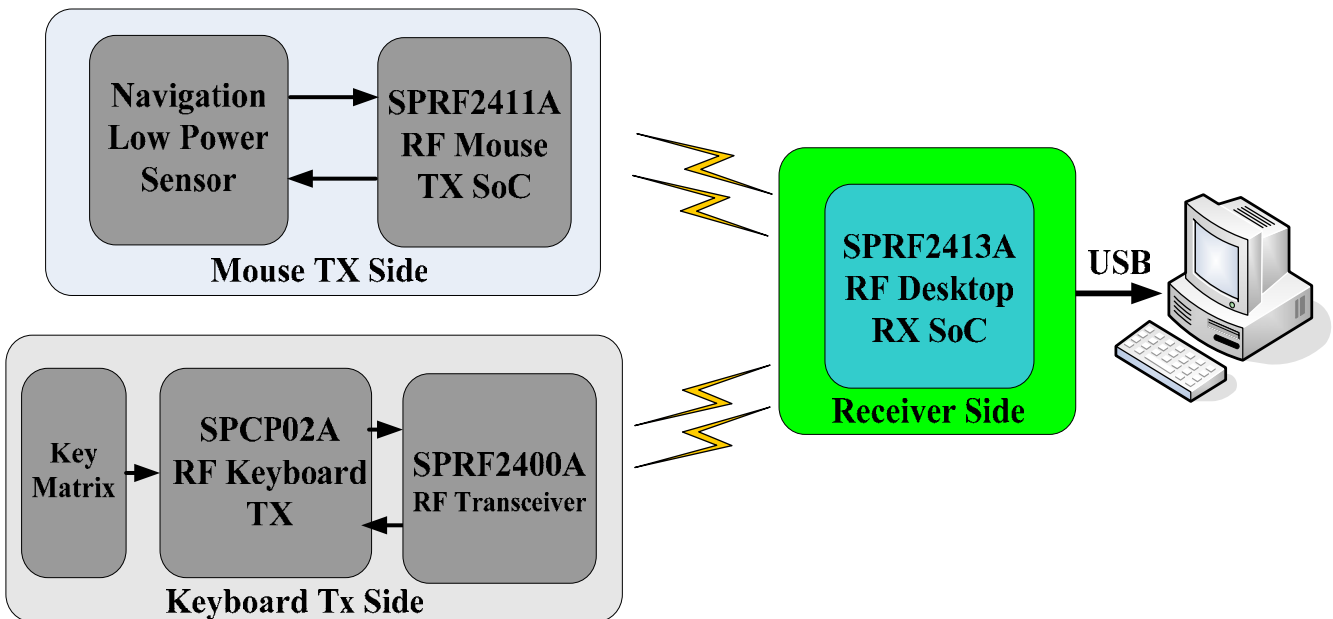

5. ELECTRICAL SPECIFICATIONS

5.1. Absolute Maximum Rating

Characteristics	Symbol	Min.	Typ.	Max.	Unit	Test Condition
Storage Temperature	T_{STR}	-40	-	125	°C	Non-programmed Device
Storage Temperature	T_{STR}	0	-	85	°C	Programmed Device
Voltage Rating on Input	V_{IN}	-0.3	-	VDD+0.3	V	
Voltage Rating on VDD	-	-0.3	-	7.0	V	
Output Voltage	V_{OUT}	0	-	VDD	V	

Note: Stresses beyond those given in the Absolute Maximum Rating table may cause operational errors or damage to the device. For normal operational conditions see AC/DC Electrical Characteristics.

5.2. Recommended Operating Conditions

Characteristics	Symbol	Min.	Typ.	Max.	Unit	Test Condition
Operating Supply Voltage	VDD	4.0	-	5.25	V	USB Mode
		-	3.0	-	V	Radio Side
Operating Ambient Temperature	T_{OPR}	0	-	70	°C	

5.3. AC Characteristics

Description	Symbol	Min.	Typ.	Max.	Unit	Test Condition
MCU Parameter						
Internal R oscillator frequency	F_{ROSC}	1.75	3.5	5.25	KHZ	
Internal 6MHz oscillator frequency	F_{OSC6M}	5.91	6.0	6.09	MHz	
USB Low-Speed Rise Time / Fall Time	T_{LR} / T_{LF}	75	-	300	ns	for Cload = 200-600P
Differential Rise and Fall Time matching	T_{LRFM}	80	-	125	%	
USB output signal Cross-over voltage	V_{CRS}	1.3	-	2.0	Volts	
Radio Parameter						
Crystal Frequency	F_{RF_OSC}		16		MHz	30ppm; $C_L=20pF$ (recommend)
Frequency deviation	F_{RF_DEV}	-100	-	+100	KHz	
Data Rate	Burst Mode	-	>0	-	1000	Kbps
	Direct Mode	-	250	-	1000	Kbps
Channel Spacing	-	-	1	-	MHz	

5.4. DC Characteristics

Name	Description	Symbol	Min.	Typ.	Max.	Unit	Test Condition
VDD	Power Consumption	I_{DD}	-	-	20	mA	VDD = 5.5V, rms value
	Suspend Current	I_{SUSP}	-	-	300	uA	VDD = 5.25V, rms value
	Low voltage Detect	V_{LVDZ}	-	3.6	-	V	
	Low voltage Reset	V_{LVRZ}	-	3.0	-	V	
VC	3.3V regulator output	V_C	3.0	3.3	3.6	V	VDD = 4.0V - 5.25V
	Current Supply capability	I_{RGL}	50			mA	@5% voltage drop
DP_CK	Input Voltage High	V_{IH}	2.0	-	-	V	
	Input Voltage Low	V_{IL}	-	-	0.8	V	
	Output Voltage High	V_{OH}	2.8	-	3.6	V	
	Output Voltage Low	V_{OL}	0	-	0.3	V	
	Input Leakage Current	I_{IZ}	-	-	10	uA	

Name	Description	Symbol	Min.	Typ.	Max.	Unit	Test Condition
	PS/2 mode Pull-up	R _{PPU}	3.5	5.0	6.5	K Ω	
DM_DA	Input Voltage High	V _{IH}	2.0	-	-	V	
	Input Voltage Low	V _{IL}	-	-	0.8	V	
	Output Voltage High	V _{OH}	2.8	-	3.6	V	
	Output Voltage Low	V _{OL}	0	-	0.3	V	
	Input Leakage Current	I _{Iz}	-	-	10	μ A	Internal pull-down disabled
	USB mode Pull-up	R _{PU1}	0.900	-	1.575	K Ω	@bus idle state
	USB mode Pull-up	R _{PU2}	1.425	-	3.090	K Ω	@non-idle state
	PS/2 mode Pull-up	R _{MPU}	3.5	5.0	6.5	K Ω	
GPIOs	Input Voltage High (PC0)	V _{IH}	2.4	-	-	V	
	Input Voltage High (PA/PB)	V _{IH5}	2.0	-	-	V	(5V mode)
	Input Voltage Low (PA/PB)	V _{IL5}	-	-	0.8	V	(5V mode)
	Input Voltage High (PA/PB)	V _{IH3}	1.9	-	-	V	(3.3V mode)
	Input Voltage Low (PA/PB)	V _{IL3}	-	-	1.0	V	(3.3V mode)
	Input Leakage Current	I _{Iz}	-	-	10	μ A	Internal pull-down disabled
	Output Voltage High	V _{OH}	2.4	-	-	V	Source current = 8.0mA, PC0 not included
	Output Voltage Low	V _{OL}	-	-	0.5	V	Sink current is 24mA for PB[1:0]; 8mA for others
	Pull-down Resistor	R _{PD}	35	50	65	K Ω	Measured at PAD = 5.0V
	Pull-up Resistor	R _{PU}	10.5	15	19.5	K Ω	Measured at PAD = 0V

5.5. Radio Characteristics

Description	Symbol	Min.	Typ.	Max.	Unit	Test Condition
Transmit Output Power	-	-	0	4	dBm	
Transmit Output Power Control Range	-	16	20	-	dBm	
Transmit Output Power Control Step	-	-	5	-	dB	
20dB Bandwidth for Modulation Carrier	-	-	1000	-	KHz	
2 nd Adjacent TX Power 2MHz	-	-	-	-20	dBm	
3 rd Adjacent TX Power 3MHz	-	-	-	-40	dBm	
Sensitivity	-	-	-93	-	dBm	0.1% BER @250Kbps
		-	-85	-	dBm	0.1% BER @1Mbps
C/I Co-Channel	-	-	9	-	dB	250Kbps
		-	5	-	dB	1Mbps
C/I 1MHz	-	-	-20	-	dB	250Kbps
		-	1	-	dB	1Mbps
C/I 2MHz	-	-	-36	-	dB	250Kbps
		-	-22	-	dB	1Mbps
C/I 3MHz	-	-	-45	-	dB	250Kbps
		-	-35	-	dB	1Mbps
C/I _{image}	-	-	-30	-	dB	250Kbps
		-	-30	-	dB	1Mbps

6. FREQUENCY HOPPING TABLE

Frequency Group1		Frequency Group2		Unit
2407	2442	2405	2443	[MHz]
2408	2447	2406	2444	
2412	2451	2409	2446	
2414	2452	2410	2448	
2417	2457	2411	2449	
2420	2458	2413	2453	
2421	2459	2415	2455	
2422	2460	2416	2456	
2427	2461	2418	2462	
2428	2465	2419	2463	
2431	2468	2423	2464	
2435	2469	2425	2466	
2436	2472	2429	2467	
2437	2473	2430	2470	
2438	2475	2432	2471	
2439	2476	2434	2474	

7. Application Reference Circuit

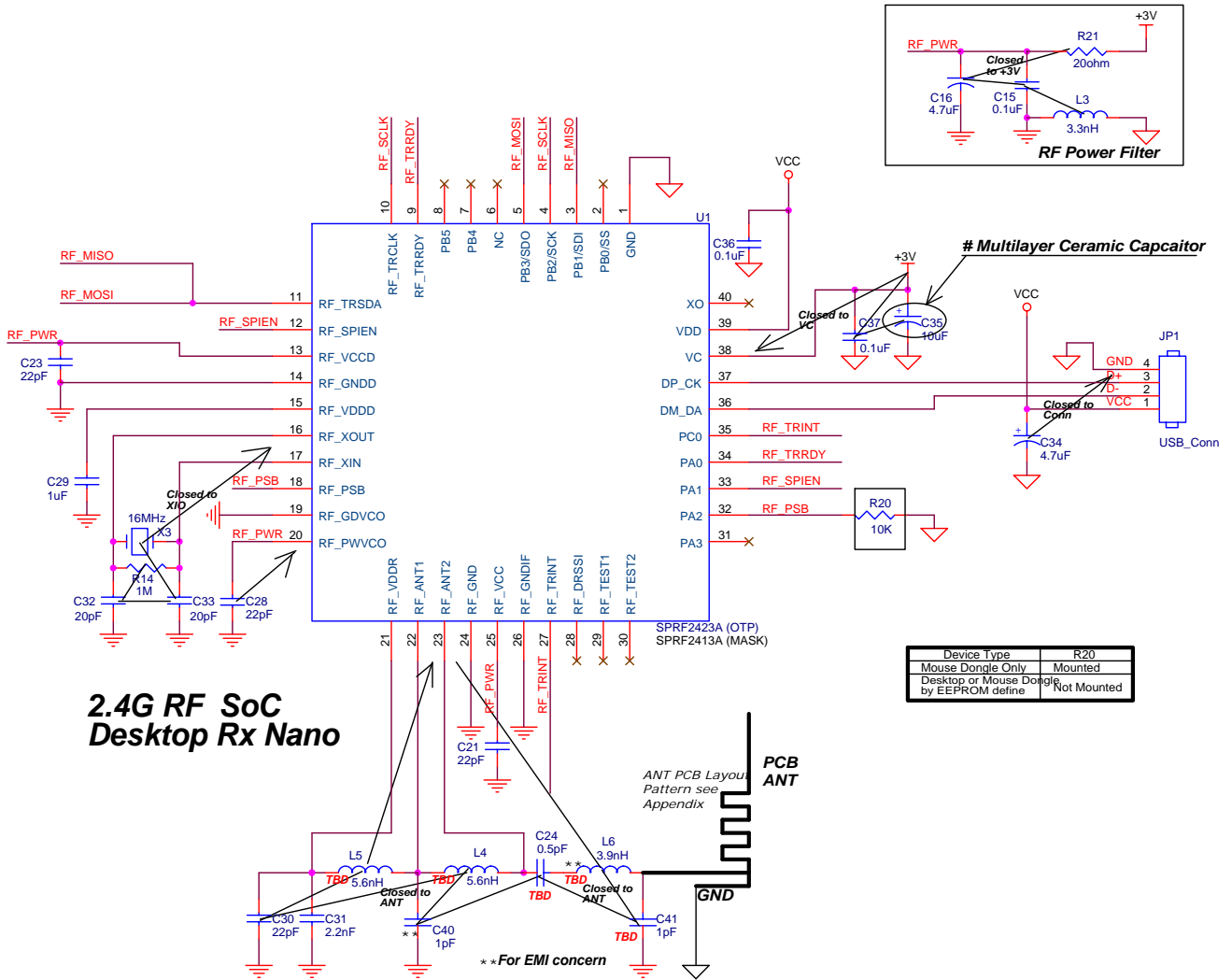

2.4GHz RF SoC Nano Receiver application circuitry

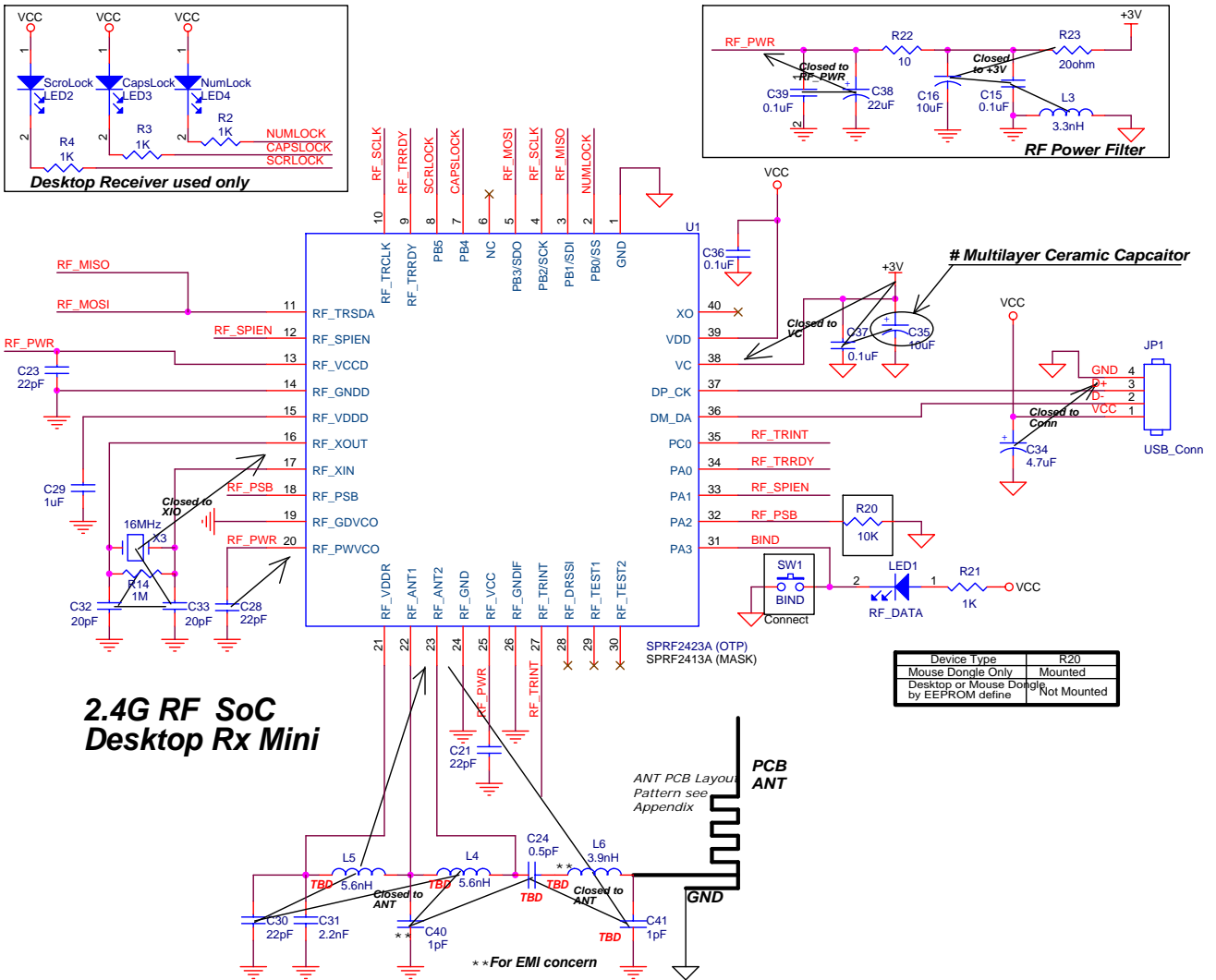

2.4GHz RF SoC Mini Receiver application circuitry

7. PACKAGE DIMENSION

