

FCC Test Report

Product Name	Gaming Mouse Dongle
Model No	P705DONGLE
FCC ID.	XW3DKP705DONGLE

Applicant	Dongguan Siliten Electronics CO.,LTD
Address	Sijia Yewu Industrial estate, Shijie Town, Dongguan, China

Date of Receipt	Sep. 16, 2019
Issue Date	Nov. 04, 2019
Report No.	1990208R-RFUSP23V00
Report Version	V1.0



The test results relate only to the samples tested.

The test results shown in the test report are traceable to the national/international standard through the calibration report of the equipment and evaluated measurement uncertainty herein.

This report must not be used to claim product endorsement by TAF or any agency of the government.

The test report shall not be reproduced without the written approval of DEKRA Testing and Certification Co., Ltd.

Test Report

Issue Date: Nov. 04, 2019

Report No.: 1990208R-RFUSP23V00



Product Name	Gaming Mouse Dongle
Applicant	Dongguan Siliten Electronics CO.,LTD
Address	Sijia Yewu Industrial estate, Shijie Town, Dongguan, China
Manufacturer	Dongguan Siliten Electronics CO.,LTD
Model No.	P705DONGLE
EUT Rated Voltage	DC 5V (Power by USB)
EUT Test Voltage	DC 5V (Power by USB)
Trade Name	ASUS
Applicable Standard	FCC CFR Title 47 Part 15 Subpart C ANSI C63.4: 2014, ANSI C63.10: 2013
Test Result	Complied

Documented By

:



(Adm. Specialist / Vita Wang)

Tested By

:



(Engineer / Jason Tuan)

Approved By

:



(Director / Vincent Lin)

TABLE OF CONTENTS

Description	Page
1. GENERAL INFORMATION	5
1.1. EUT Description.....	5
1.2. Operational Description	7
1.3. Tested System Details.....	8
1.4. Configuration of Tested System	8
1.5. EUT Exercise Software	8
1.6. Test Facility	9
1.7. List of Test Equipment	10
2. Conducted Emission.....	12
2.1. Test Setup	12
2.2. Limits	12
2.3. Test Procedure	12
2.4. Uncertainty	12
2.5. Test Result of Conducted Emission.....	13
3. Peak Power Output	17
3.1. Test Setup	17
3.2. Limits	17
3.3. Test Procedure	17
3.4. Uncertainty	17
3.5. Test Result of Peak Power Output.....	18
4. Radiated Emission.....	19
4.1. Test Setup	19
4.2. Limits	20
4.3. Test Procedure	21
4.4. Uncertainty	22
4.5. Test Result of Radiated Emission.....	23
5. RF antenna conducted test.....	37
5.1. Test Setup	37
5.2. Limits	37
5.3. Test Procedure	37
5.4. Uncertainty	37
5.5. Test Result of RF antenna conducted test.....	38
6. Band Edge	39
6.1. Test Setup	39
6.2. Limits	39
6.3. Test Procedure	40
6.4. Uncertainty	40
6.5. Test Result of Band Edge	41
7. 6dB Bandwidth	49
7.1. Test Setup	49
7.2. Limits	49

7.3.	Test Procedure	49
7.4.	Uncertainty	49
7.5.	Test Result of 6dB Bandwidth.....	50
8.	Power Density	53
8.1.	Test Setup	53
8.2.	Limits	53
8.3.	Test Procedure	53
8.4.	Uncertainty	53
8.5.	Test Result of Power Density	54
9.	Duty Cycle	57
9.1.	Test Setup	57
9.2.	Test Procedure	57
9.3.	Uncertainty	57
9.4.	Test Result of Duty Cycle.....	58
10.	EMI Reduction Method During Compliance Testing	59
Attachment 1: EUT Test Photographs		
Attachment 2: EUT Detailed Photographs		

1. GENERAL INFORMATION

1.1. EUT Description

Product Name	Gaming Mouse Dongle
Trade Name	ASUS
Model No.	P705DONGLE
FCC ID.	XW3DKP705DONGLE
Frequency Range	2403-2480MHz
Number of Channels	78CH
Channel Separation	1MHz
Type of Modulation	GFSK
Antenna Type	Printed on PCB
Antenna Gain	Refer to the table “Antenna List”
Channel Control	Auto

Antenna List

No.	Manufacturer	Part No.	Antenna Type	Peak Gain
1	ASUS	P705DONGLE	Printed on PCB	-2.27dBi for 2.4 GHz

Note: The antenna of EUT conforms to FCC 15.203.

Center Frequency of Each Channel:

Channel	Frequency	Channel	Frequency	Channel	Frequency	Channel	Frequency
Channel 01:	2403 MHz	Channel 21:	2423 MHz	Channel 41:	2443 MHz	Channel 61:	2463 MHz
Channel 02:	2404 MHz	Channel 22:	2424 MHz	Channel 42:	2444 MHz	Channel 62:	2464 MHz
Channel 03:	2405 MHz	Channel 23:	2425 MHz	Channel 43:	2445 MHz	Channel 63:	2465 MHz
Channel 04:	2406 MHz	Channel 24:	2426 MHz	Channel 44:	2446 MHz	Channel 64:	2466 MHz
Channel 05:	2407 MHz	Channel 25:	2427 MHz	Channel 45:	2447 MHz	Channel 65:	2467 MHz
Channel 06:	2408 MHz	Channel 26:	2428 MHz	Channel 46:	2448 MHz	Channel 66:	2468 MHz
Channel 07:	2409 MHz	Channel 27:	2429 MHz	Channel 47:	2449 MHz	Channel 67:	2469 MHz
Channel 08:	2410 MHz	Channel 28:	2430 MHz	Channel 48:	2450 MHz	Channel 68:	2470 MHz
Channel 09:	2411 MHz	Channel 29:	2431 MHz	Channel 49:	2451 MHz	Channel 69:	2471 MHz
Channel 10:	2412 MHz	Channel 30:	2432 MHz	Channel 50:	2452 MHz	Channel 70:	2472 MHz
Channel 11:	2413 MHz	Channel 31:	2433 MHz	Channel 51:	2453 MHz	Channel 71:	2473 MHz
Channel 12:	2414 MHz	Channel 32:	2434 MHz	Channel 52:	2454 MHz	Channel 72:	2474 MHz
Channel 13:	2415 MHz	Channel 33:	2435 MHz	Channel 53:	2455 MHz	Channel 73:	2475 MHz
Channel 14:	2416 MHz	Channel 34:	2436 MHz	Channel 54:	2456 MHz	Channel 74:	2476 MHz
Channel 15:	2417 MHz	Channel 35:	2437 MHz	Channel 55:	2457 MHz	Channel 75:	2477 MHz
Channel 16:	2418 MHz	Channel 36:	2438 MHz	Channel 56:	2458 MHz	Channel 76:	2478 MHz
Channel 17:	2419 MHz	Channel 37:	2439 MHz	Channel 57:	2459 MHz	Channel 77:	2479 MHz
Channel 18:	2420 MHz	Channel 38:	2440 MHz	Channel 58:	2460 MHz	Channel 78:	2480 MHz
Channel 19:	2421 MHz	Channel 39:	2441 MHz	Channel 59:	2461 MHz		
Channel 20:	2422 MHz	Channel 40:	2442 MHz	Channel 60:	2462 MHz		

Note:

1. The EUT is a Gaming Mouse Dongle with a built-in 2.4GHz GFSK transceiver.
2. Regarding to the operation frequency, the lowest, middle and highest frequency are selected to perform the test.
3. These tests are conducted on a sample for the purpose of demonstrating compliance of 2.4GHz transmitter with Part 15 Subpart C Paragraph 15.247 of spread spectrum devices
4. The radiation measurements are performed in X, Y, Z axis positioning. Only the worst case is shown in the report.

Test Mode:	Mode 1: Transmit
------------	------------------

1.3. Tested System Details

The types for all equipment, plus descriptions of all cables used in the tested system (including inserted cards) are:

Product	Manufacturer	Model No.	Serial No.	Power Cord	
1	Notebook PC	DELL	Latitude 5580	GDZN7H2	Non-Shielded, 0.8m

Signal Cable Type	Signal cable Description
A	USB Cable
	Non-Shielded, 2m

1.4. Configuration of Tested System

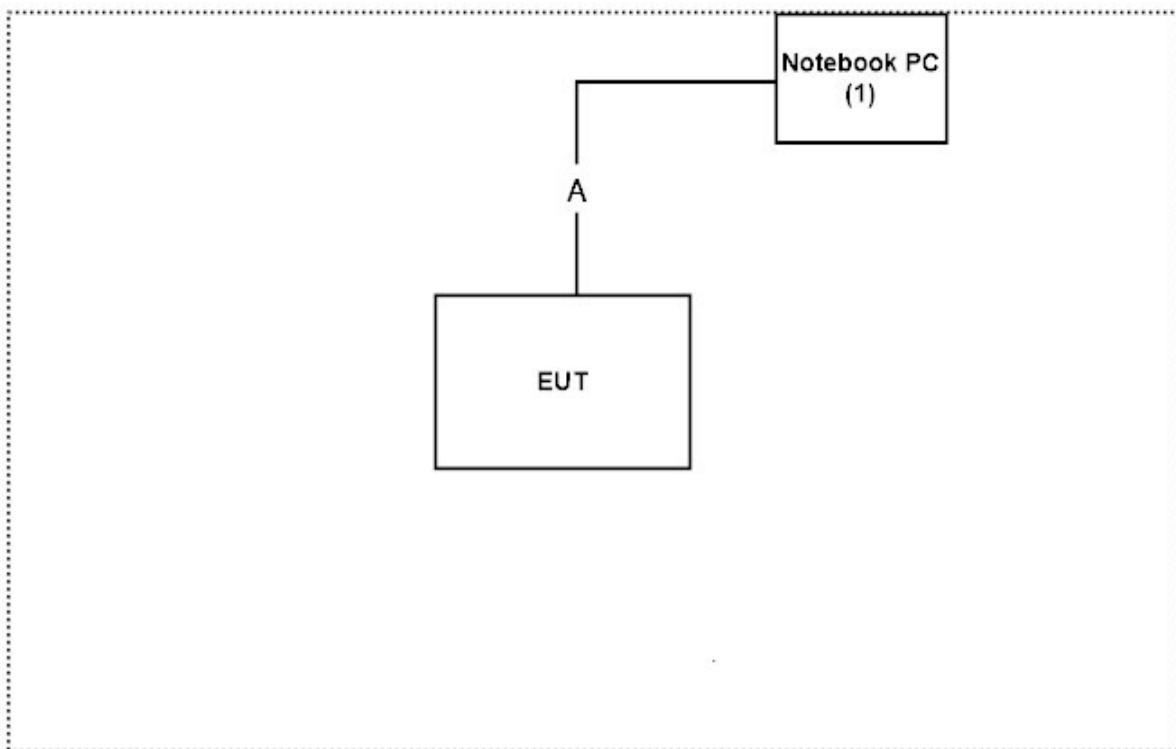

1.5. EUT Exercise Software

1. Setup the EUT as shown in Section 1.4.
2. Execute software “Cmd” on the EUT.
3. Configure the test mode, the test channel, and the data rate.
4. Press “OK” to start the continuous Transmit.
5. Verify that the EUT works properly.

1.6. Test Facility

Ambient conditions in the laboratory:

Items	Required (IEC 68-1)	Actual
Temperature (°C)	15-35	20-35
Humidity (%RH)	25-75	50-65
Barometric pressure (mbar)	860-1060	950-1000

USA : FCC Registration Number: TW3023

Canada : IC Registration Number: 4075A

Site Description: Accredited by TAF
Accredited Number: 3023

Test Laboratory: DEKRA Testing and Certification Co., Ltd
Address: No.5-22, Ruishukeng, Linkou Dist., New Taipei City 24451,
Taiwan, R.O.C.
Phone number: 886-2-8601-3788
Fax number: 886-2-8601-3789
Email address: info.tw@dekra.com
Website: <http://www.dekra.com.tw>

1.7. List of Test Equipment

Conducted measurements /CB3/SR8

	Equipment	Manufacturer	Model No.	Serial No.	Cali. Date	Due. Date
	Temperature Chamber	WIT GROUP	TH-1S-B	EQ-201-00146	2019/02/26	2020/02/25
X	Spectrum Analyzer	Agilent	N9010A	MY53470892	2019/09/25	2020/09/24
X	Peak Power Analyzer	Keysight	8990B	MY51000410	2019/07/30	2020/07/29
X	Wideband Power Sensor	Keysight	N1923A	MY56080003	2019/07/30	2020/07/29
X	Wideband Power Sensor	Keysight	N1923A	MY56080004	2019/07/30	2020/07/29
X	EMI Test Receiver	R&S	ESCS 30	100369	2018/11/19	2019/11/18
X	LISN	R&S	ENV216	101105	2019/04/10	2020/04/09
X	LISN	R&S	ESH3-Z5	836679/014	2019/04/10	2020/04/09
X	Coaxial Cable	DEKRA	RG 400	LC018-RG	2019/06/21	2020/06/20

Note:

1. All equipments are calibrated every one year.
2. The test instruments marked with "X" are used to measure the final test results.
3. Test Software version :DEKRA Conduction Test SystemV9.0.5.

For Radiated measurements /Site3/CB8

	Equipment	Manufacturer	Model No.	Serial No.	Cali. Date	Due. Date
X	Spectrum Analyzer	R&S	FSP40	100170	2019/03/11	2020/03/10
X	Loop Antenna	Teseq	HLA6121	37133	2019/10/15	2021/10/14
X	Bilog Antenna	Schaffner Chase	CBL6112B	2794	2019/06/23	2020/06/22
X	Coaxial Cable	DEKRA	L1907-001C	280280.F141.1000D	2019/07/10	2020/07/09
X	Amplifier	EMCI	EMC001330	980254	2019/08/22	2020/08/21
X	Horn Antenna	ETS-LINDGREN	3117	00228113	2019/05/02	2020/05/01
X	Coaxial Cable	DEKRA	L1907-002C	280280.F141.1000D	2019/07/10	2020/07/09
X	Amplifier	EMCI	EMC05820SE	980362	2019/06/26	2020/06/25
X	Amplifier	EMCI	EMC051845SE	SN980632	2019/08/08	2020/08/07
	Horn Antenna	Com-Power	AH-1840	101101	2019/10/19	2020/10/18
	Amplifier + Cable	EMCI	EMC184045SE	980369	2019/04/16	2020/04/15
	Bilog Antenna	Schaffner Chase	CBL6112B	2916	2019/06/23	2020/06/22
	Coaxial Cable	DEKRA	L1907-003C	00100A1B3A120M	2019/07/10	2020/07/09
	Amplifier	EMCI	EMC001330	980255	2019/06/28	2020/06/27
X	Filter	MICRO-TRONICS	BRM50702	G270	2019/08/08	2020/08/07
	Filter	MICRO-TRONICS	BRM50716	G196	2019/08/08	2020/08/07

Note:

1. All equipments are calibrated every one year.
2. The test instruments marked with "X" are used to measure the final test results.
3. Test Software version :QuieTek EMI System V2.1.134.

2. Conducted Emission

2.1. Test Setup

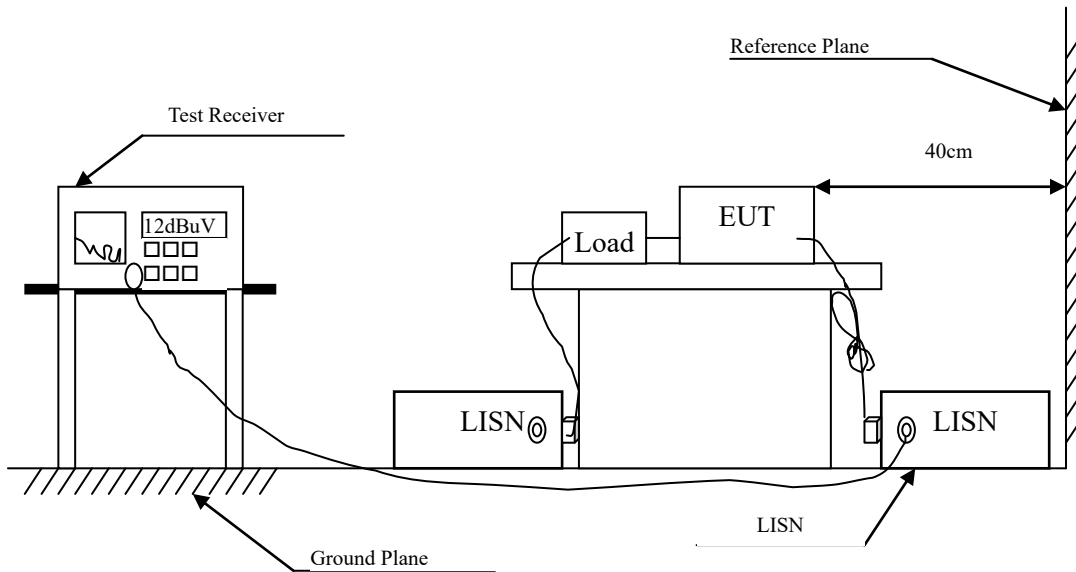

2.2. Limits

FCC Part 15 Subpart C Paragraph 15.207 (dBuV) Limit		
Frequency MHz	Limits	
	QP	AVG
0.15 - 0.50	66-56	56-46
0.50-5.0	56	46
5.0 - 30	60	50

2.3. Test Procedure

The EUT and simulators are connected to the main power through a line impedance stabilization network (L.I.S.N.). This provides a 50 ohm /50uH coupling impedance for the measuring equipment. The peripheral devices are also connected to the main power through a LISN that provides a 50ohm /50uH coupling impedance with 50ohm termination. (Please refers to the block diagram of the test setup and photographs.)

Both sides of A.C. line are checked for maximum conducted interference. In order to find the maximum emission, the relative positions of equipment and all of the interface cables must be changed according to ANSI C63.4: 2014 on conducted measurement.

Conducted emissions were invested over the frequency range from 0.15MHz to 30MHz using a receiver bandwidth of 9kHz.

2.4. Uncertainty

± 2.26 dB

2.5. Test Result of Conducted Emission

Product : Gaming Mouse Dongle
 Test Item : Conducted Emission Test
 Power Line : Line (+)
 Test Date : 2019/10/28
 Test Mode : Mode 1: Transmit (2440MHz)

Line 1

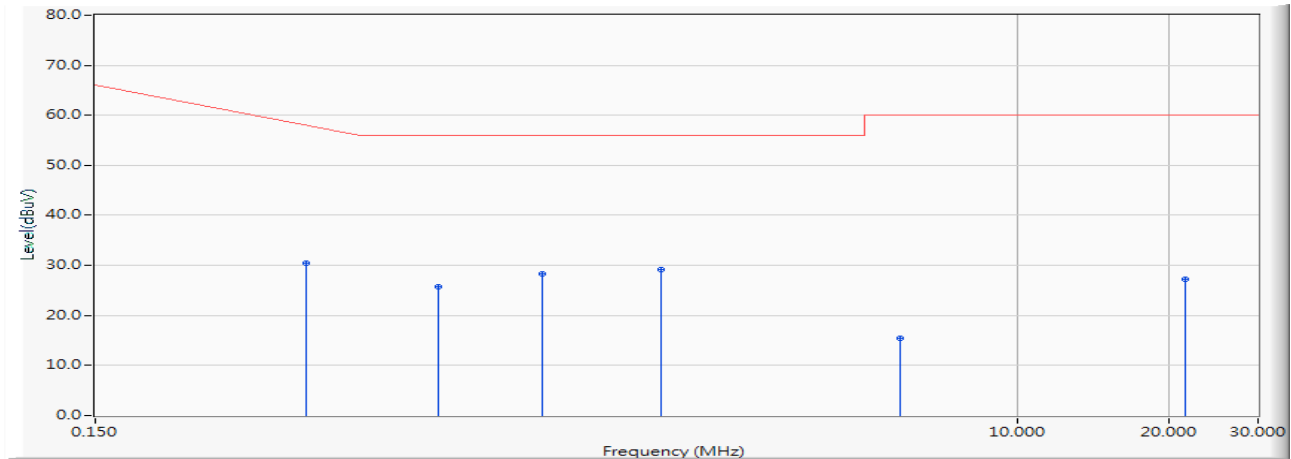

		Frequency (MHz)	Correct Factor (dB)	Reading Level (dBuV)	Measure Level (dBuV)	Margin (dB)	Limit (dBuV)	Detector Type
1		0.392	9.681	20.700	30.381	-28.705	59.086	QUASIPeAK
2		0.716	9.699	16.100	25.799	-30.201	56.000	QUASIPeAK
3		1.146	9.722	18.540	28.262	-27.738	56.000	QUASIPeAK
4	*	1.974	9.777	19.450	29.227	-26.773	56.000	QUASIPeAK
5		5.873	9.903	5.500	15.403	-44.597	60.000	QUASIPeAK
6		21.462	10.195	16.970	27.165	-32.835	60.000	QUASIPeAK

Note:

1. All Reading Levels are Quasi-Peak and average value.
2. “ * “ means the worst emission level.
3. Measurement Level = Reading Level + Correct Factor

Product : Gaming Mouse Dongle
 Test Item : Conducted Emission Test
 Power Line : Line (+)
 Test Date : 2019/10/28
 Test Mode : Mode 1: Transmit (2440MHz)

Line 1

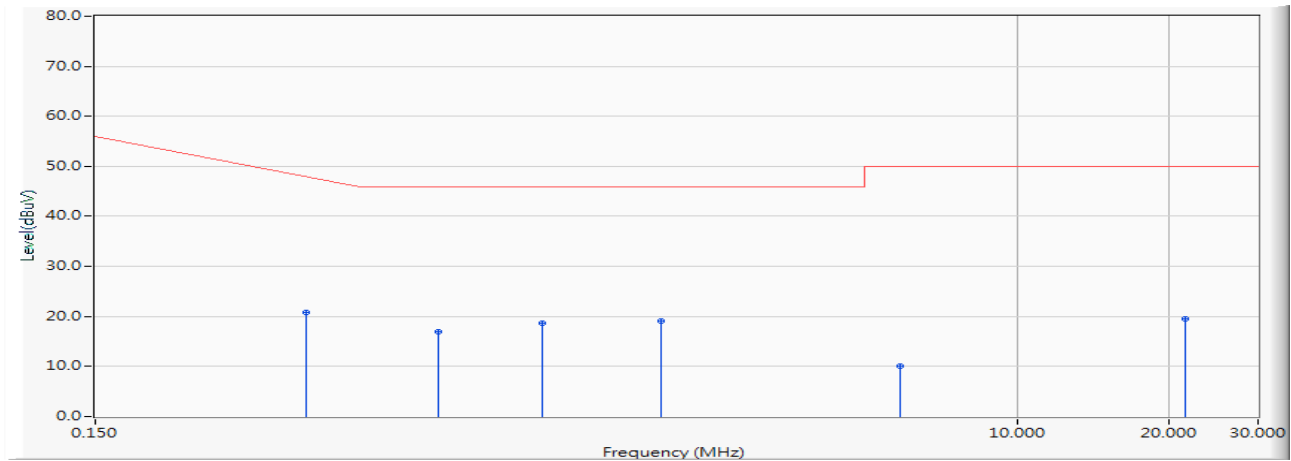

		Frequency (MHz)	Correct Factor (dB)	Reading Level (dBuV)	Measure Level (dBuV)	Margin (dB)	Limit (dBuV)	Detector Type
1		0.392	9.681	11.230	20.911	-28.175	49.086	AVERAGE
2		0.716	9.699	7.210	16.909	-29.091	46.000	AVERAGE
3		1.146	9.722	8.900	18.622	-27.378	46.000	AVERAGE
4	*	1.974	9.777	9.300	19.077	-26.923	46.000	AVERAGE
5		5.873	9.903	0.280	10.183	-39.817	50.000	AVERAGE
6		21.462	10.195	9.320	19.515	-30.485	50.000	AVERAGE

Note:

1. All Reading Levels are Quasi-Peak and average value.
2. “ * “ means the worst emission level.
3. Measurement Level = Reading Level + Correct Factor

Product : Gaming Mouse Dongle
 Test Item : Conducted Emission Test
 Power Line : Line (-)
 Test Date : 2019/10/28
 Test Mode : Mode 1: Transmit (2440MHz)

Line2

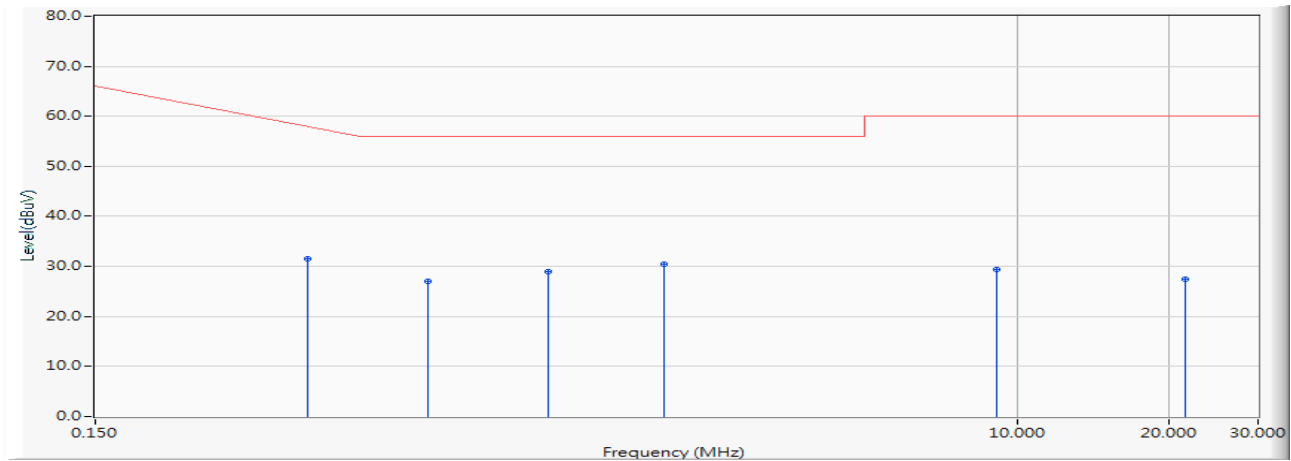

		Frequency (MHz)	Correct Factor (dB)	Reading Level (dBuV)	Measure Level (dBuV)	Margin (dB)	Limit (dBuV)	Detector Type
1		0.396	9.711	21.860	31.571	-27.400	58.971	QUASIPeAK
2		0.681	9.727	17.250	26.977	-29.023	56.000	QUASIPeAK
3		1.185	9.764	19.260	29.024	-26.976	56.000	QUASIPeAK
4	*	2.009	9.819	20.540	30.359	-25.641	56.000	QUASIPeAK
5		9.115	10.064	19.410	29.474	-30.526	60.000	QUASIPeAK
6		21.466	10.385	17.050	27.435	-32.565	60.000	QUASIPeAK

Note:

1. All Reading Levels are Quasi-Peak and average value.
2. “ * “ means the worst emission level.
3. Measurement Level = Reading Level + Correct Factor

Product : Gaming Mouse Dongle
 Test Item : Conducted Emission Test
 Power Line : Line (-)
 Test Date : 2019/10/28
 Test Mode : Mode 1: Transmit (2440MHz)

Line2

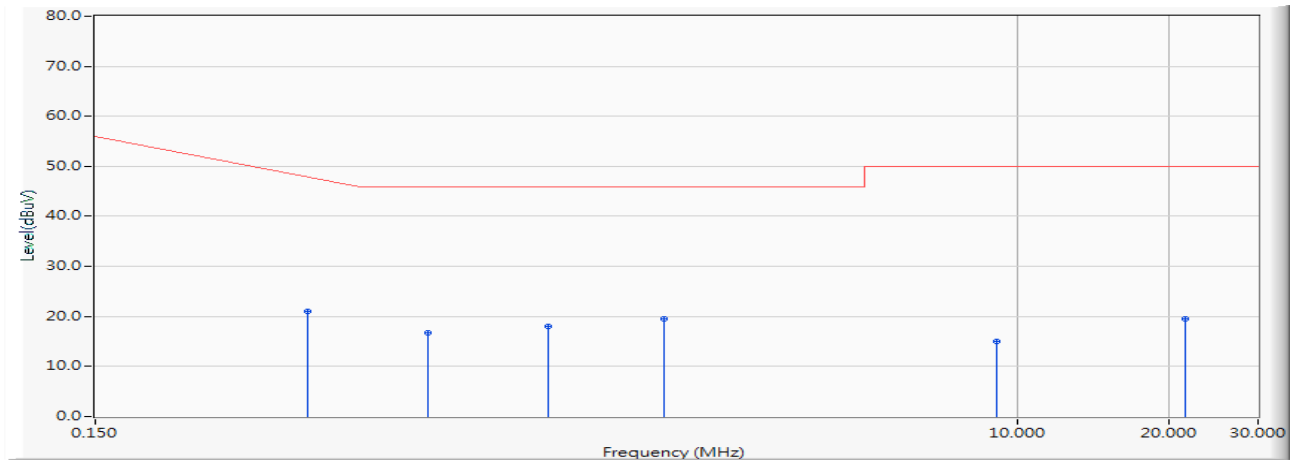

		Frequency (MHz)	Correct Factor (dB)	Reading Level (dBuV)	Measure Level (dBuV)	Margin (dB)	Limit (dBuV)	Detector Type
1		0.396	9.711	11.290	21.001	-27.970	48.971	AVERAGE
2		0.681	9.727	6.960	16.687	-29.313	46.000	AVERAGE
3		1.185	9.764	8.150	17.914	-28.086	46.000	AVERAGE
4	*	2.009	9.819	9.760	19.579	-26.421	46.000	AVERAGE
5		9.115	10.064	4.990	15.054	-34.946	50.000	AVERAGE
6		21.466	10.385	9.050	19.435	-30.565	50.000	AVERAGE

Note:

1. All Reading Levels are Quasi-Peak and average value.
2. “ * “ means the worst emission level.
3. Measurement Level = Reading Level + Correct Factor

3. Peak Power Output

3.1. Test Setup

Conducted Measurement

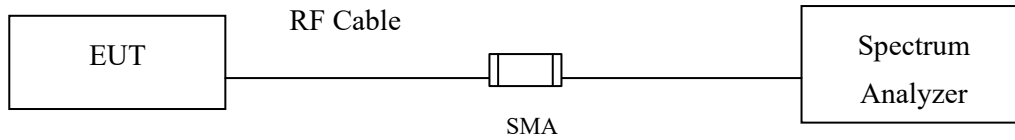

3.2. Limits

The maximum peak power shall be less 1 Watt.

3.3. Test Procedure

The EUT was tested according to C63.10:2013 for compliance to FCC 47CFR 15.247 requirements. The maximum peak conducted output power using C63.10:2013 Section 11.9.1.3 PKPM1 Peak power meter method

3.4. Uncertainty

± 1.19 dB

3.5. Test Result of Peak Power Output

Product : Gaming Mouse Dongle
Test Item : Peak Power Output Data
Test Site : No.3 OATS
Test Date : 2019/10/22
Test Mode : Mode 1: Transmit

Channel No.	Frequency (MHz)	Average Power (dBm)	Peak Power (dBm)	Required Limit (dBm)	Result
01	2403	-1.29	-1.03	<30dBm	Pass
38	2440	-1.18	-0.89	<30dBm	Pass
78	2480	-0.95	-0.70	<30dBm	Pass

Note: Peak Power Output Value = Reading value on peak power meter + cable loss

4. Radiated Emission

4.1. Test Setup

Radiated Emission Under 30MHz

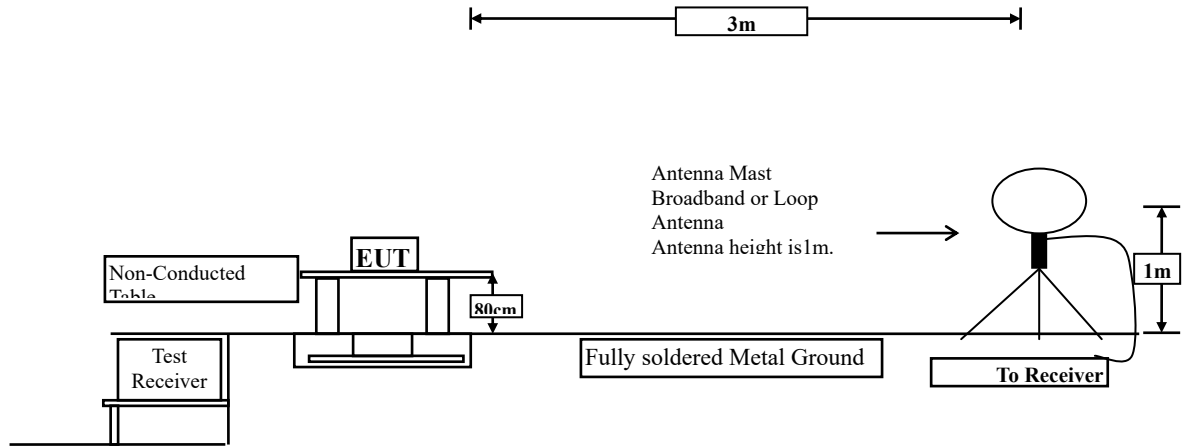

Radiated Emission Below 1GHz

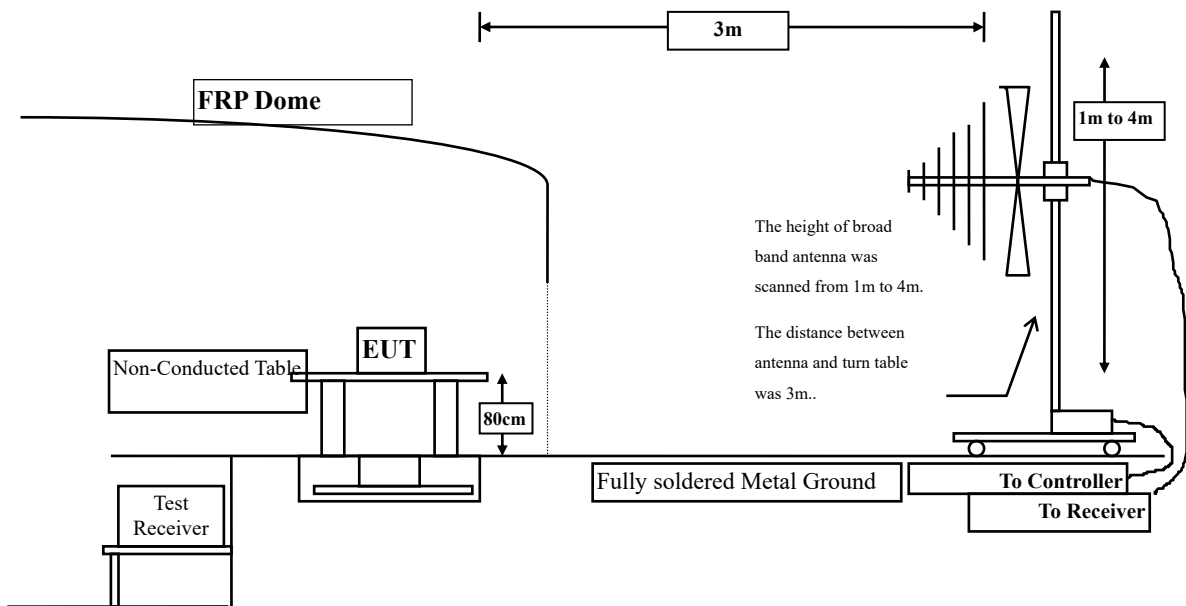

Radiated Emission Above 1GHz

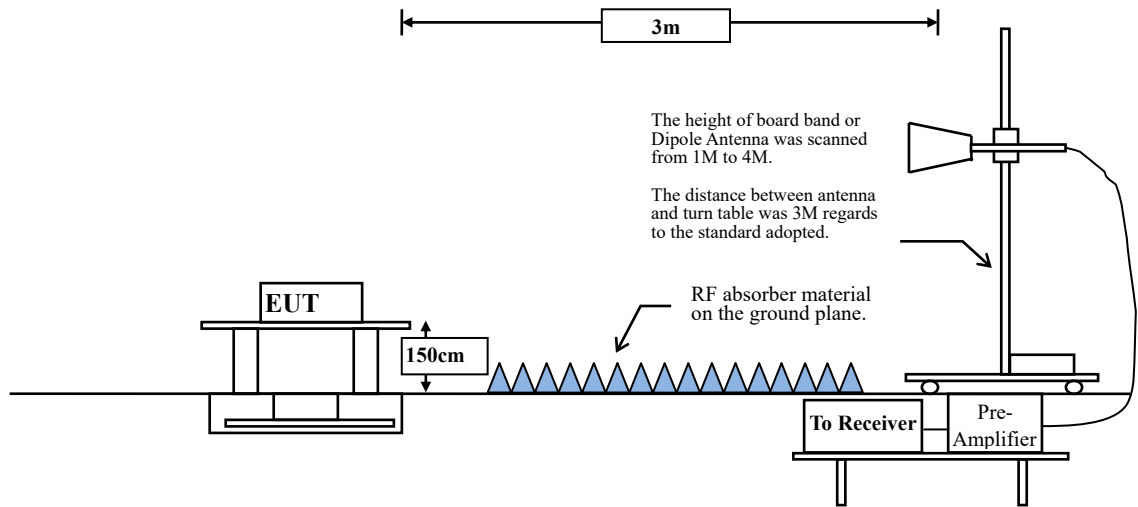

4.2. Limits

Emissions radiated outside of the specified frequency bands, except for harmonics, shall be attenuated by at least 20dB below the level of the fundamental or to the general radiated emission limits in paragraph 15.209, whichever is the lesser attenuation.

FCC Part 15 Subpart C Paragraph 15.209(a) Limits		
Frequency MHz	uV/m @3m	dBuV/m@3m
30-88	100	40
88-216	150	43.5
216-960	200	46
Above 960	500	54

Remarks: E field strength (dBuV/m) = 20 log E field strength (uV/m)

4.3. Test Procedure

The EUT was setup according to ANSI C63.10: 2013 and tested according to C63.10:2013 Section 11.12.1 for compliance to FCC 47CFR 15.247 requirements.

Measuring the frequency range below 1GHz, the EUT is placed on a turn table which is 0.8 meter above ground, when measuring the frequency range above 1GHz, the EUT is placed on a turn table which is 1.5 meter above ground.

The turn table is rotated 360 degrees to determine the position of the maximum emission level.

The EUT was positioned such that the distance from antenna to the EUT was 3 meters.

The antenna is scanned between 1 meter and 4 meters to find out the maximum emission level. This is repeated for both horizontal and vertical polarization of the antenna. In order to find the maximum emission, all of the interface cables were manipulated according to ANSI C63.10: 2013 on radiated measurement.

The resolution bandwidth below 30MHz setting on the field strength meter is 9kHz and 30MHz~1GHz is 120kHz and above 1GHz is 1MHz.

Radiated emission measurements below 30MHz are made using Loop Antenna and 30MHz~1GHz are made using broadband Bilog antenna and above 1GHz are made using Horn Antennas.

The measurement is divided into the Preliminary Measurement and the Final Measurement.

The suspected frequencies are searched for in Preliminary Measurement with the measurement antenna kept pointed at the source of the emission both in azimuth and elevation, with the polarization of the antenna oriented for maximum response. The antenna is pointed at an angle towards the source of the emission, and the EUT is rotated in both height and polarization to maximize the measured emission. The emission is kept within the illumination area of the 3 dB bandwidth of the antenna.

The worst radiated emission is measured in the Open Area Test Site on the Final Measurement.

The measurement frequency range from 9kHz - 10th Harmonic of fundamental was investigated.

RBW and VBW Parameter setting:

According to C63.10 Section 11.12.2.4 Peak measurement procedure

RBW = as specified in Table 1.

VBW \geq 3 x RBW.

Table 1 —RBW as a function of frequency

Frequency	RBW
9-150 kHz	200-300 Hz
0.15-30 MHz	9-10 kHz
30-1000 MHz	100-120 kHz
> 1000 MHz	1 MHz

According to C63.10 Section 11.12.2.5 Average measurement procedure

RBW = 1MHz.

VBW = 10Hz, when duty cycle \geq 98 %

VBW \geq 1/T, when duty cycle < 98 %

(T refers to the minimum transmission duration over which the transmitter is on and is transmitting at its maximum power control level for the tested mode of operation.)

2.4GHz band	Duty Cycle (%)	T (ms)	1/T (Hz)	VBW (Hz)
GFSK	100	--	--	10

Note: Duty Cycle Refer to Section 9.

4.4. Uncertainty

\pm 4.08 dB above 1GHz

\pm 4.22 dB below 1GHz

4.5. Test Result of Radiated Emission

Product : Gaming Mouse Dongle
 Test Item : Harmonic Radiated Emission Data
 Test Date : 2019/10/21
 Test Mode : Mode 1: Transmit (2403MHz)

Horizontal

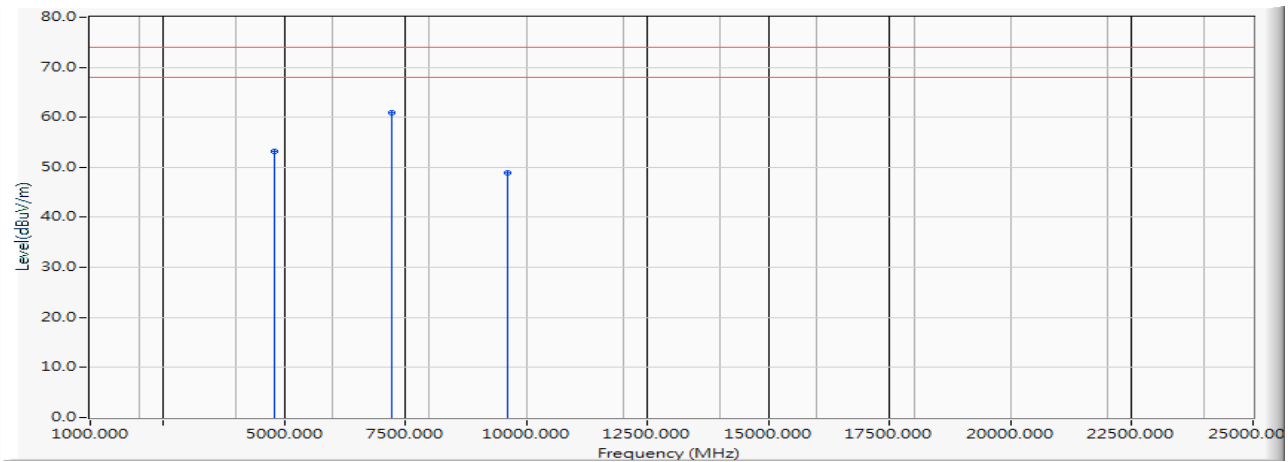

		Frequency (MHz)	Correct Factor (dB)	Reading Level (dBuV)	Measure Level (dBuV/m)	Margin (dB)	Limit (dBuV/m)	Detector Type
1		4806.000	4.623	48.560	53.183	-20.817	74.000	PEAK
2	*	7209.000	11.700	49.180	60.880	-13.120	74.000	PEAK
3		9612.000	11.906	37.010	48.916	-25.084	74.000	PEAK

Note:

1. All Readings below 1GHz are Quasi-Peak, above 1GHz are performed with peak and/or average measurements as necessary.
2. Measurement Level = Reading Level + Correct Factor.
3. Correct Factor = Antenna factor + Cable loss – Amplifier gain.
4. The average measurement was not performed when the peak measured data under the limit of average detection.
5. The emission levels of other frequencies are very lower than the limit and not show in test report.

Product : Gaming Mouse Dongle
 Test Item : Harmonic Radiated Emission Data
 Test Date : 2019/10/21
 Test Mode : Mode 1: Transmit (2403MHz)

Horizontal

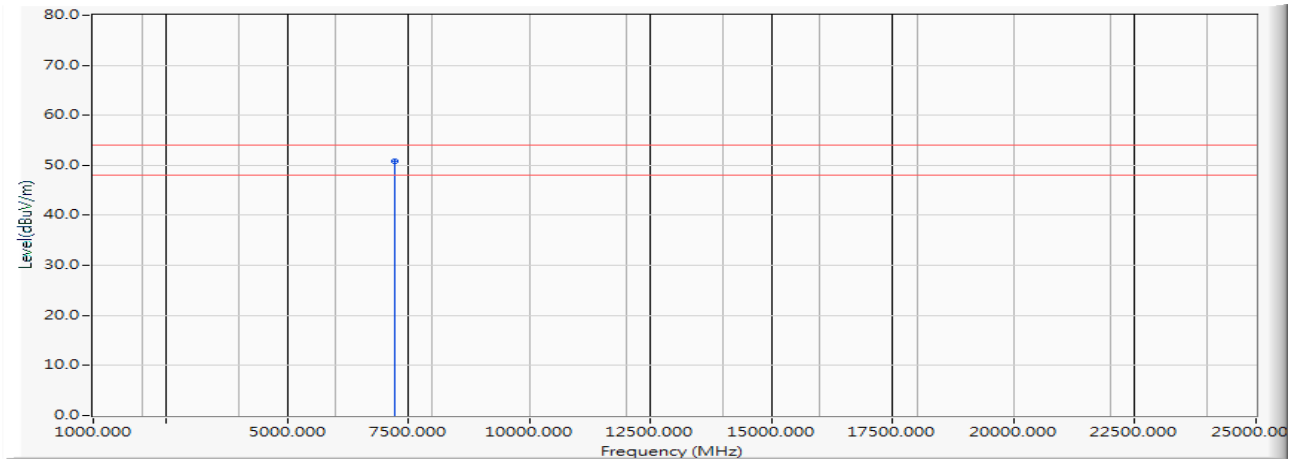

		Frequency (MHz)	Correct Factor (dB)	Reading Level (dBuV)	Measure Level (dBuV/m)	Margin (dB)	Limit (dBuV/m)	Detector Type
1	*	7209.000	11.700	39.060	50.760	-3.240	54.000	AVERAGE

Note:

1. All Readings below 1GHz are Quasi-Peak, above 1GHz are performed with peak and/or average measurements as necessary.
2. Measurement Level = Reading Level + Correct Factor.
3. Correct Factor = Antenna factor + Cable loss – Amplifier gain.
4. The average measurement was not performed when the peak measured data under the limit of average detection.
5. The emission levels of other frequencies are very lower than the limit and not show in test report.

Product : Gaming Mouse Dongle
 Test Item : Harmonic Radiated Emission Data
 Test Date : 2019/10/21
 Test Mode : Mode 1: Transmit (2403MHz)

Vertical

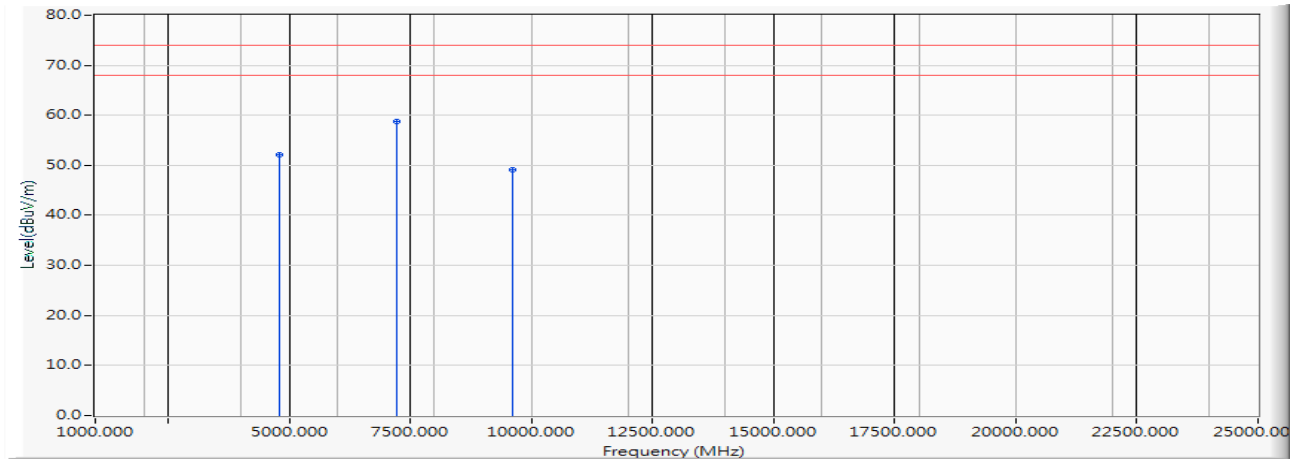

		Frequency (MHz)	Correct Factor (dB)	Reading Level (dBuV)	Measure Level (dBuV/m)	Margin (dB)	Limit (dBuV/m)	Detector Type
1		4806.000	4.623	47.590	52.213	-21.787	74.000	PEAK
2	*	7209.000	11.700	47.110	58.810	-15.190	74.000	PEAK
3		9612.000	11.906	37.250	49.156	-24.844	74.000	PEAK

Note:

1. All Readings below 1GHz are Quasi-Peak, above 1GHz are performed with peak and/or average measurements as necessary.
2. Measurement Level = Reading Level + Correct Factor.
3. Correct Factor = Antenna factor + Cable loss – Amplifier gain.
4. The average measurement was not performed when the peak measured data under the limit of average detection.
5. The emission levels of other frequencies are very lower than the limit and not show in test report.

Product : Gaming Mouse Dongle
 Test Item : Harmonic Radiated Emission Data
 Test Date : 2019/10/21
 Test Mode : Mode 1: Transmit (2403MHz)

Vertical

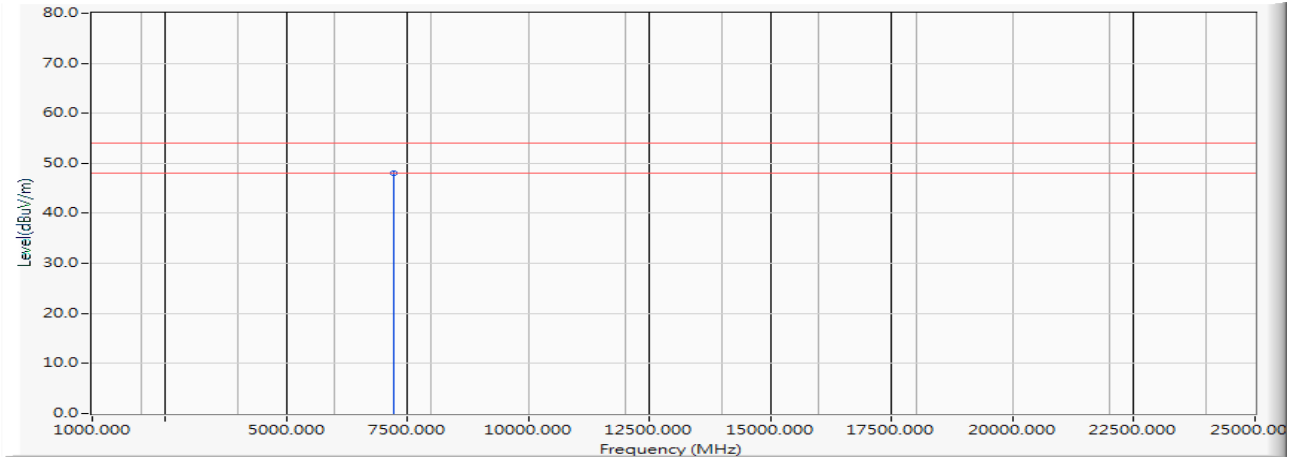

		Frequency (MHz)	Correct Factor (dB)	Reading Level (dBuV)	Measure Level (dBuV/m)	Margin (dB)	Limit (dBuV/m)	Detector Type
1	*	7209.000	11.700	36.310	48.010	-5.990	54.000	AVERAGE

Note:

1. All Readings below 1GHz are Quasi-Peak, above 1GHz are performed with peak and/or average measurements as necessary.
2. Measurement Level = Reading Level + Correct Factor.
3. Correct Factor = Antenna factor + Cable loss – Amplifier gain.
4. The average measurement was not performed when the peak measured data under the limit of average detection.
5. The emission levels of other frequencies are very lower than the limit and not show in test report.

Product : Gaming Mouse Dongle
 Test Item : Harmonic Radiated Emission Data
 Test Date : 2019/10/21
 Test Mode : Mode 1: Transmit (2440MHz)

Horizontal

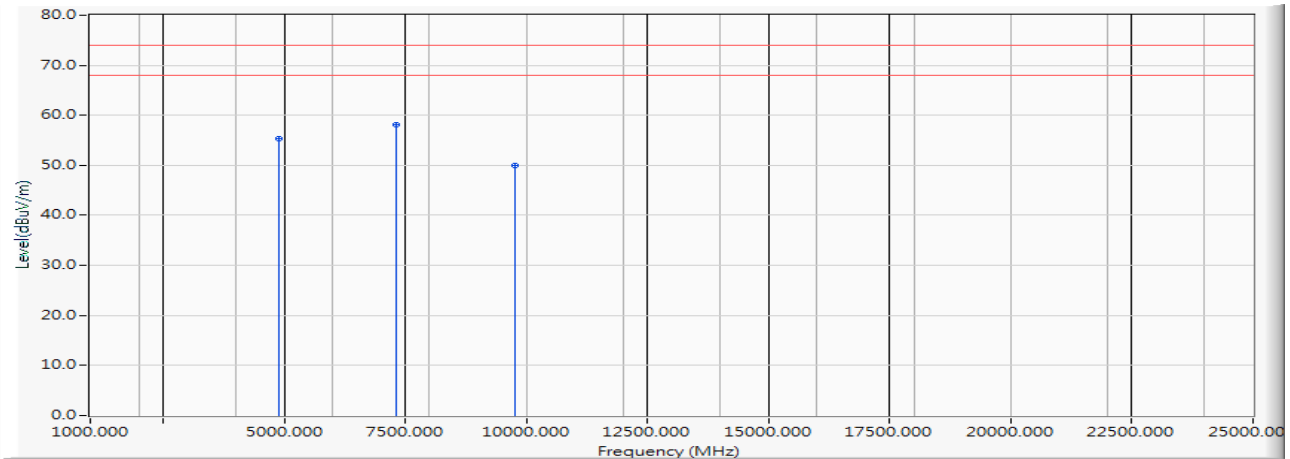

		Frequency (MHz)	Correct Factor (dB)	Reading Level (dBuV)	Measure Level (dBuV/m)	Margin (dB)	Limit (dBuV/m)	Detector Type
1		4880.000	5.302	49.970	55.272	-18.728	74.000	PEAK
2	*	7320.000	11.795	46.240	58.035	-15.965	74.000	PEAK
3		9760.000	11.929	38.000	49.930	-24.070	74.000	PEAK

Note:

1. All Readings below 1GHz are Quasi-Peak, above 1GHz are performed with peak and/or average measurements as necessary.
2. Measurement Level = Reading Level + Correct Factor.
3. Correct Factor = Antenna factor + Cable loss – Amplifier gain.
4. The average measurement was not performed when the peak measured data under the limit of average detection.
5. The emission levels of other frequencies are very lower than the limit and not show in test report.

Product : Gaming Mouse Dongle
 Test Item : Harmonic Radiated Emission Data
 Test Date : 2019/10/21
 Test Mode : Mode 1: Transmit (2440MHz)

Horizontal

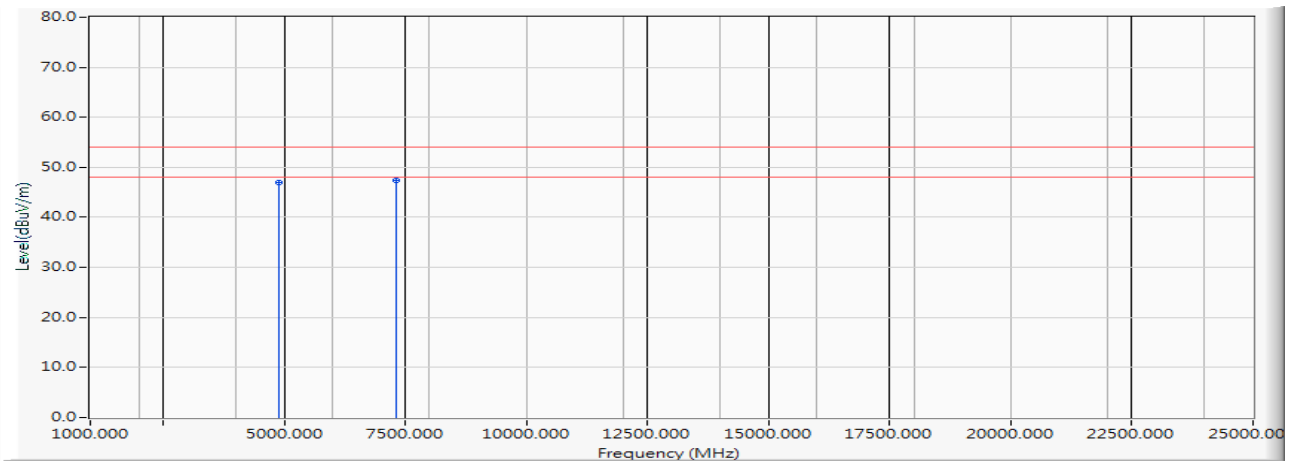

		Frequency (MHz)	Correct Factor (dB)	Reading Level (dBuV)	Measure Level (dBuV/m)	Margin (dB)	Limit (dBuV/m)	Detector Type
1		4880.000	5.302	41.590	46.892	-7.108	54.000	AVERAGE
2	*	7320.000	11.795	35.620	47.415	-6.585	54.000	AVERAGE

Note:

1. All Readings below 1GHz are Quasi-Peak, above 1GHz are performed with peak and/or average measurements as necessary.
2. Measurement Level = Reading Level + Correct Factor.
3. Correct Factor = Antenna factor + Cable loss – Amplifier gain.
4. The average measurement was not performed when the peak measured data under the limit of average detection.
5. The emission levels of other frequencies are very lower than the limit and not show in test report.

Product : Gaming Mouse Dongle
 Test Item : Harmonic Radiated Emission Data
 Test Date : 2019/10/21
 Test Mode : Mode 1: Transmit (2440MHz)

Vertical

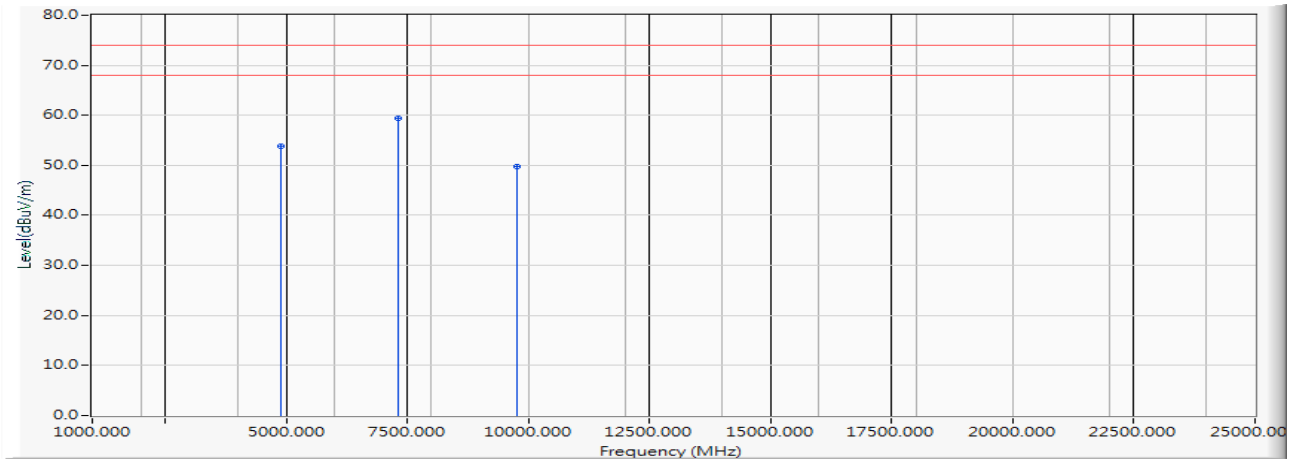

		Frequency (MHz)	Correct Factor (dB)	Reading Level (dBuV)	Measure Level (dBuV/m)	Margin (dB)	Limit (dBuV/m)	Detector Type
1		4880.000	5.302	48.610	53.912	-20.088	74.000	PEAK
2	*	7320.000	11.795	47.700	59.495	-14.505	74.000	PEAK
3		9760.000	11.929	37.820	49.750	-24.250	74.000	PEAK

Note:

1. All Readings below 1GHz are Quasi-Peak, above 1GHz are performed with peak and/or average measurements as necessary.
2. Measurement Level = Reading Level + Correct Factor.
3. Correct Factor = Antenna factor + Cable loss – Amplifier gain.
4. The average measurement was not performed when the peak measured data under the limit of average detection.
5. The emission levels of other frequencies are very lower than the limit and not show in test report.

Product : Gaming Mouse Dongle
 Test Item : Harmonic Radiated Emission Data
 Test Date : 2019/10/21
 Test Mode : Mode 1: Transmit (2440MHz)

Vertical

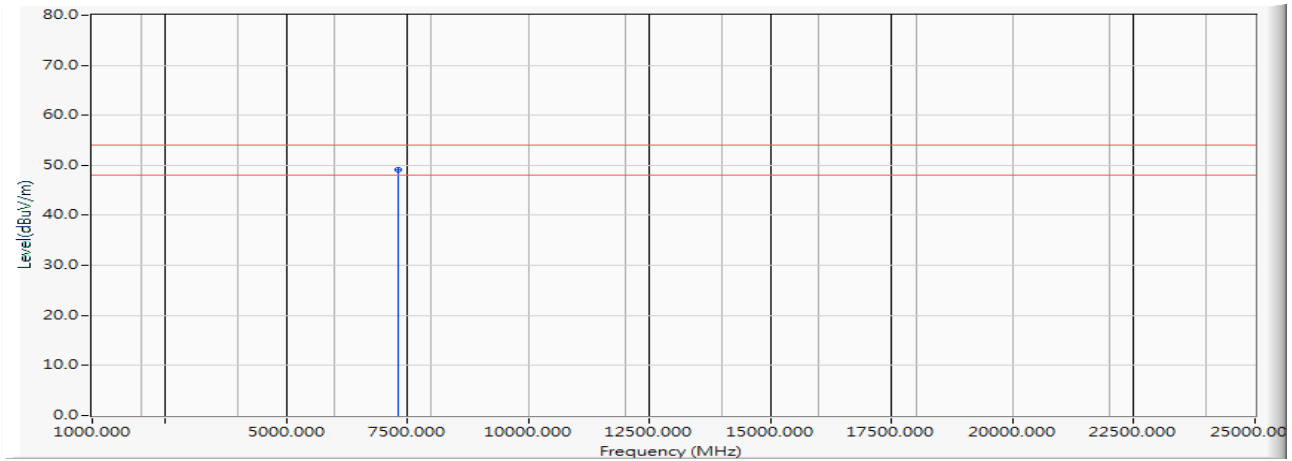

		Frequency (MHz)	Correct Factor (dB)	Reading Level (dBuV)	Measure Level (dBuV/m)	Margin (dB)	Limit (dBuV/m)	Detector Type
1	*	7320.000	11.795	37.240	49.035	-4.965	54.000	AVERAGE

Note:

1. All Readings below 1GHz are Quasi-Peak, above 1GHz are performed with peak and/or average measurements as necessary.
2. Measurement Level = Reading Level + Correct Factor.
3. Correct Factor = Antenna factor + Cable loss – Amplifier gain.
4. The average measurement was not performed when the peak measured data under the limit of average detection.
5. The emission levels of other frequencies are very lower than the limit and not show in test report.

Product : Gaming Mouse Dongle
 Test Item : Harmonic Radiated Emission Data
 Test Date : 2019/10/21
 Test Mode : Mode 1: Transmit (2480MHz)

Horizontal

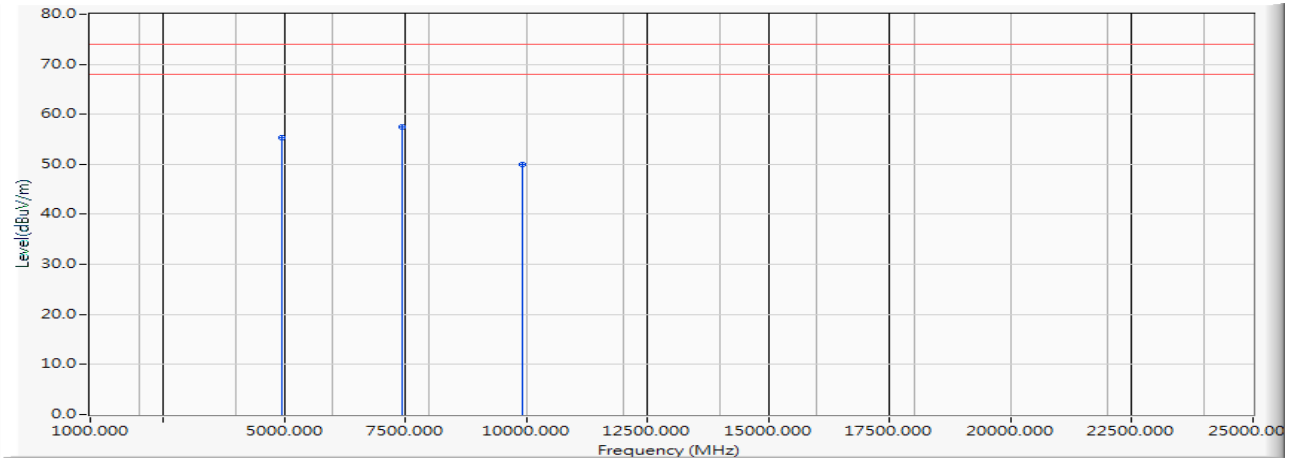

		Frequency (MHz)	Correct Factor (dB)	Reading Level (dBuV)	Measure Level (dBuV/m)	Margin (dB)	Limit (dBuV/m)	Detector Type
1		4960.000	6.035	49.400	55.435	-18.565	74.000	PEAK
2	*	7440.000	10.977	46.470	57.447	-16.553	74.000	PEAK
3		9920.000	12.758	37.120	49.877	-24.123	74.000	PEAK

Note:

1. All Readings below 1GHz are Quasi-Peak, above 1GHz are performed with peak and/or average measurements as necessary.
2. Measurement Level = Reading Level + Correct Factor.
3. Correct Factor = Antenna factor + Cable loss – Amplifier gain.
4. The average measurement was not performed when the peak measured data under the limit of average detection.
5. The emission levels of other frequencies are very lower than the limit and not show in test report.

Product : Gaming Mouse Dongle
 Test Item : Harmonic Radiated Emission Data
 Test Date : 2019/10/21
 Test Mode : Mode 1: Transmit (2480MHz)

Horizontal

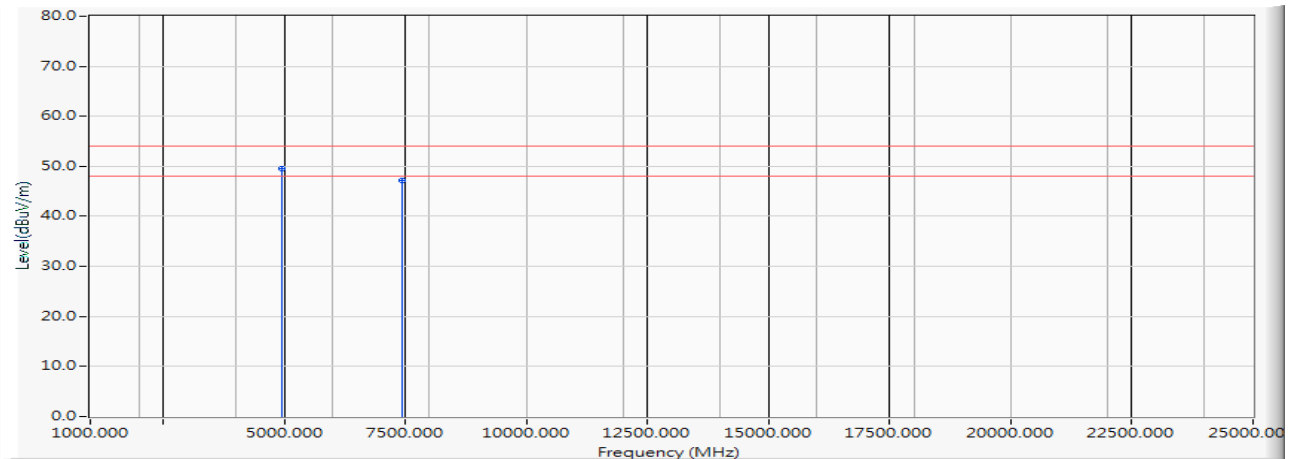

		Frequency (MHz)	Correct Factor (dB)	Reading Level (dBuV)	Measure Level (dBuV/m)	Margin (dB)	Limit (dBuV/m)	Detector Type
1	*	4960.000	6.035	43.510	49.545	-4.455	54.000	AVERAGE
2		7440.000	10.977	36.190	47.167	-6.833	54.000	AVERAGE

Note:

1. All Readings below 1GHz are Quasi-Peak, above 1GHz are performed with peak and/or average measurements as necessary.
2. Measurement Level = Reading Level + Correct Factor.
3. Correct Factor = Antenna factor + Cable loss – Amplifier gain.
4. The average measurement was not performed when the peak measured data under the limit of average detection.
5. The emission levels of other frequencies are very lower than the limit and not show in test report.

Product : Gaming Mouse Dongle
 Test Item : Harmonic Radiated Emission Data
 Test Date : 2019/10/21
 Test Mode : Mode 1: Transmit (2480MHz)

Vertical

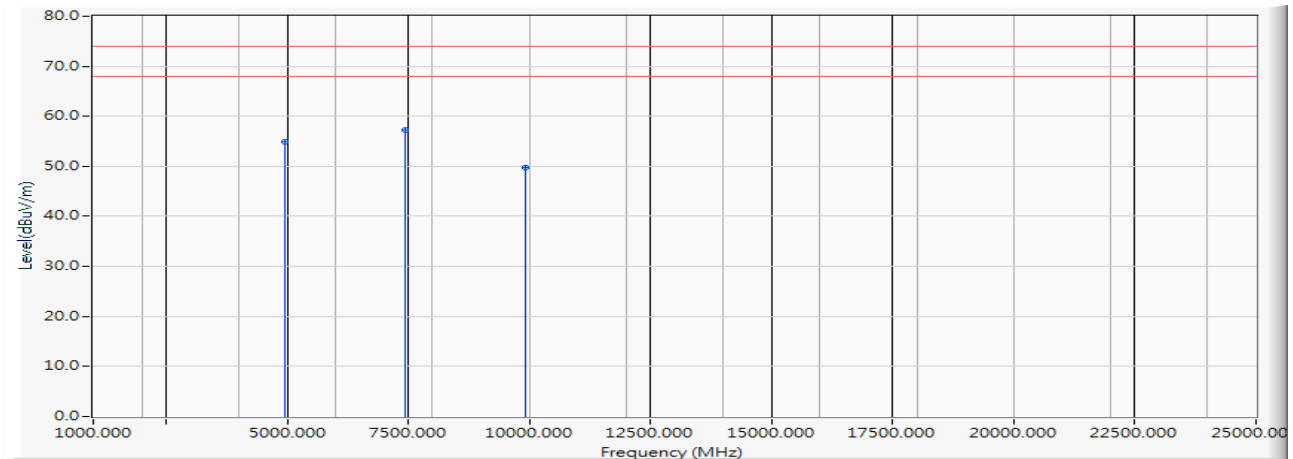

	Frequency (MHz)	Correct Factor (dB)	Reading Level (dBuV)	Measure Level (dBuV/m)	Margin (dB)	Limit (dBuV/m)	Detector Type
1	4960.000	6.035	48.770	54.805	-19.195	74.000	PEAK
2	* 7440.000	10.977	46.290	57.267	-16.733	74.000	PEAK
3	9920.000	12.758	36.950	49.707	-24.293	74.000	PEAK

Note:

1. All Readings below 1GHz are Quasi-Peak, above 1GHz are performed with peak and/or average measurements as necessary.
2. Measurement Level = Reading Level + Correct Factor.
3. Correct Factor = Antenna factor + Cable loss – Amplifier gain.
4. The average measurement was not performed when the peak measured data under the limit of average detection.
5. The emission levels of other frequencies are very lower than the limit and not show in test report.

Product : Gaming Mouse Dongle
 Test Item : Harmonic Radiated Emission Data
 Test Date : 2019/10/21
 Test Mode : Mode 1: Transmit (2480MHz)

Vertical

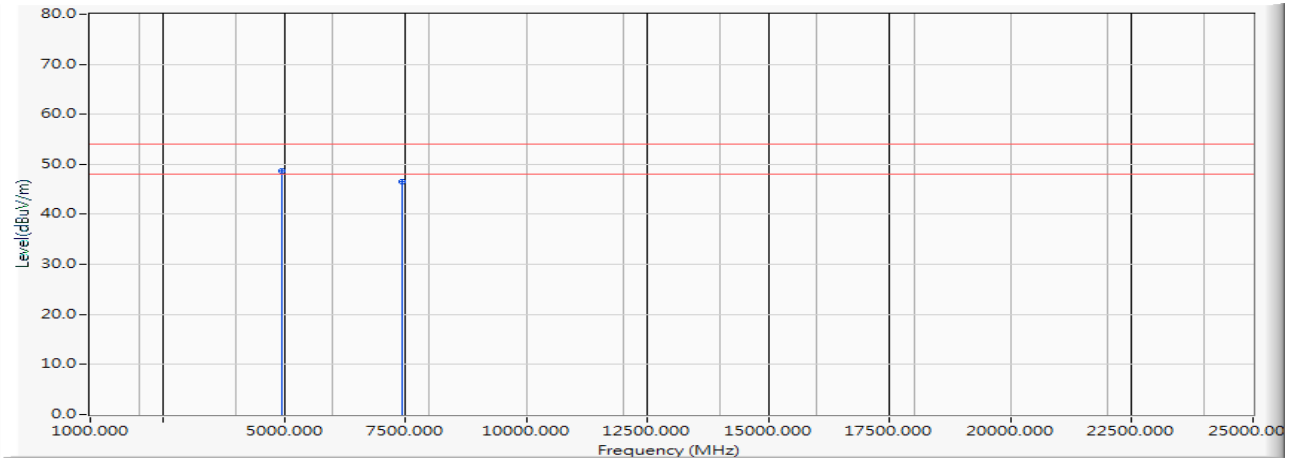

		Frequency (MHz)	Correct Factor (dB)	Reading Level (dBuV)	Measure Level (dBuV/m)	Margin (dB)	Limit (dBuV/m)	Detector Type
1	*	4960.000	6.035	42.650	48.685	-5.315	54.000	AVERAGE
2		7440.000	10.977	35.570	46.547	-7.453	54.000	AVERAGE

Note:

1. All Readings below 1GHz are Quasi-Peak, above 1GHz are performed with peak and/or average measurements as necessary.
2. Measurement Level = Reading Level + Correct Factor.
3. Correct Factor = Antenna factor + Cable loss – Amplifier gain.
4. The average measurement was not performed when the peak measured data under the limit of average detection.
5. The emission levels of other frequencies are very lower than the limit and not show in test report.

Product : Gaming Mouse Dongle
 Test Item : General Radiated Emission Data
 Test Date : 2019/10/28
 Test Mode : Mode 1: Transmit (2440MHz)

Horizontal

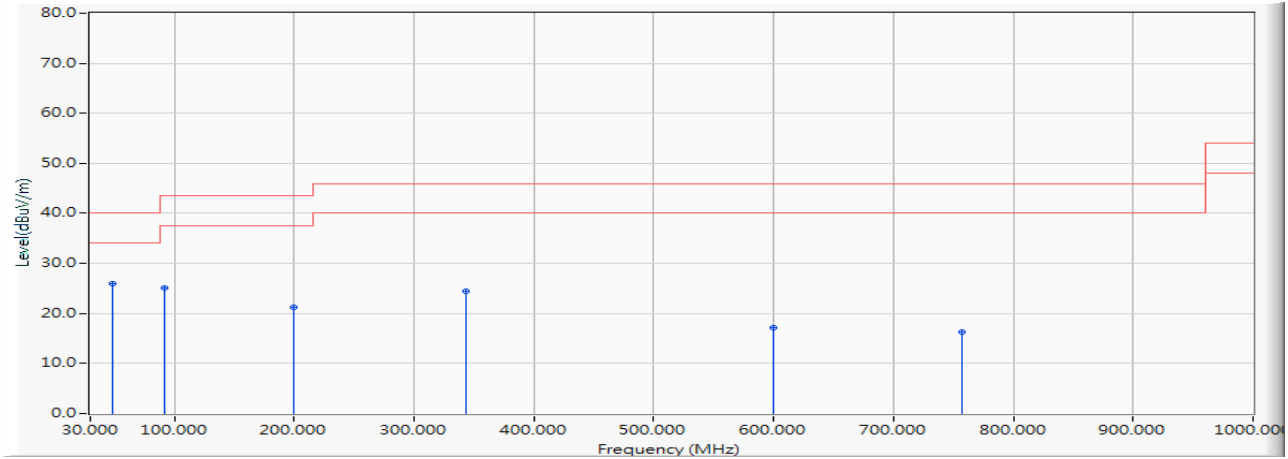

		Frequency (MHz)	Correct Factor (dB)	Reading Level (dBuV)	Measure Level (dBuV/m)	Margin (dB)	Limit (dBuV/m)	Detector Type
1	*	48.275	-16.986	42.978	25.992	-14.008	40.000	QUASIPeAK
2		91.855	-16.156	41.325	25.169	-18.331	43.500	QUASIPeAK
3		200.101	-17.004	38.300	21.296	-22.204	43.500	QUASIPeAK
4		343.493	-11.381	35.787	24.406	-21.594	46.000	QUASIPeAK
5		599.348	28.625	-11.561	17.064	-56.936	74.000	QUASIPeAK
6		756.797	-5.846	22.173	16.327	-29.673	46.000	QUASIPeAK

Note:

1. All Readings below 1GHz are Quasi-Peak, above 1GHz are performed with peak and/or average measurements as necessary.
2. Measurement Level = Reading Level + Correct Factor.
3. Correct Factor = Antenna factor + Cable loss – Amplifier gain.
4. The average measurement was not performed when the peak measured data under the limit of average detection.
5. The emission levels of other frequencies are very lower than the limit and not show in test report.

Product : Gaming Mouse Dongle
 Test Item : General Radiated Emission Data
 Test Date : 2019/10/28
 Test Mode : Mode 1: Transmit (2440MHz)

Vertical

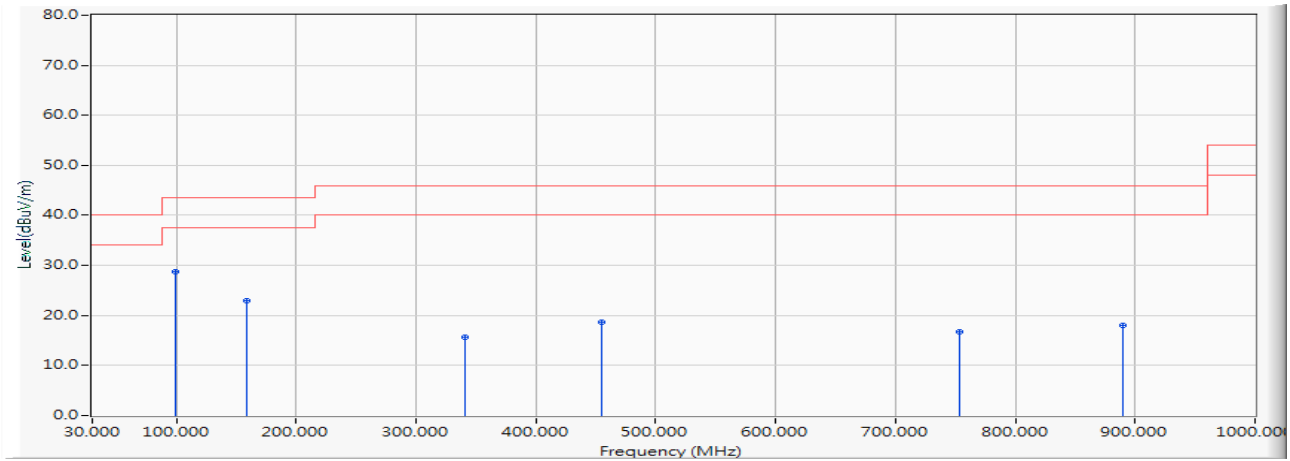

		Frequency (MHz)	Correct Factor (dB)	Reading Level (dBuV)	Measure Level (dBuV/m)	Margin (dB)	Limit (dBuV/m)	Detector Type
1	*	98.884	-15.868	44.581	28.713	-14.787	43.500	QUASIPeAK
2		159.333	-18.561	41.456	22.894	-20.606	43.500	QUASIPeAK
3		340.681	-11.681	27.399	15.719	-30.281	46.000	QUASIPeAK
4		454.551	-8.272	26.898	18.626	-27.374	46.000	QUASIPeAK
5		753.986	-6.031	22.693	16.662	-29.338	46.000	QUASIPeAK
6		890.348	-6.892	24.846	17.953	-28.047	46.000	QUASIPeAK

Note:

1. All Readings below 1GHz are Quasi-Peak, above 1GHz are performed with peak and/or average measurements as necessary.
2. Measurement Level = Reading Level + Correct Factor.
3. Correct Factor = Antenna factor + Cable loss – Amplifier gain.
4. The average measurement was not performed when the peak measured data under the limit of average detection.
5. The emission levels of other frequencies are very lower than the limit and not show in test report.

5. RF antenna conducted test

5.1. Test Setup

RF antenna Conducted Measurement:

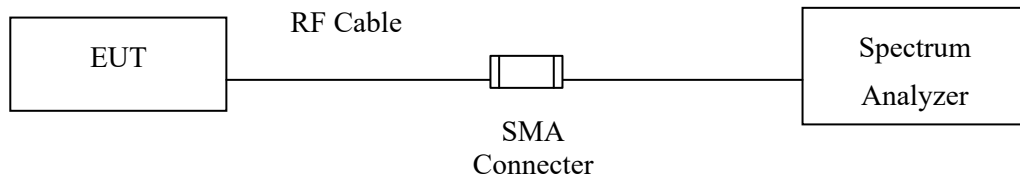

5.2. Limits

In any 100 kHz bandwidth outside the frequency band in which the spread spectrum intentional radiator is operating, the radio frequency power that is produced by the intentional radiator shall be at least 20 dB below that in the 100 kHz bandwidth within the band that contains the highest level of the desired power, based on either an RF conducted or a radiated measurement. Attenuation below the general limits specified in Section 15.209(a) is not required. In addition, radiated emissions which fall in the restricted bands, as defined in Section 15.205(a), must also comply with the radiated emission limits specified in Section 15.209(a) (see Section 15.205(c)).

5.3. Test Procedure

The EUT was tested according to C63.10:2013 Section 11.11 for compliance to FCC 47CFR 15.247 requirements.

Set RBW = 100 kHz, Set VBW > RBW, scan up through 10th harmonic.

5.4. Uncertainty

The measurement uncertainty

Conducted is defined as $\pm 1.20\text{dB}$

5.5. Test Result of RF antenna conducted test

Product : Gaming Mouse Dongle
Test Item : RF antenna conducted test
Test Site : No.3 OATS
Test Mode : Mode 1: Transmit

(2403MHz) 30M-25GHz

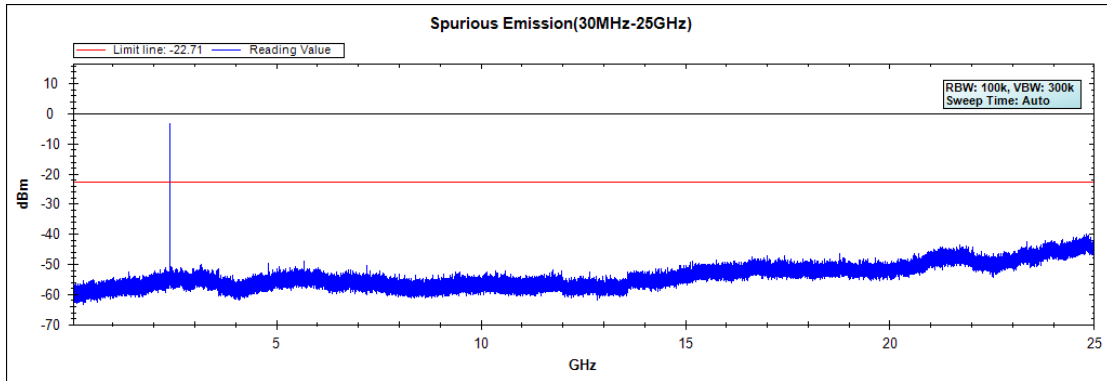

(2440MHz) 30M-25GHz

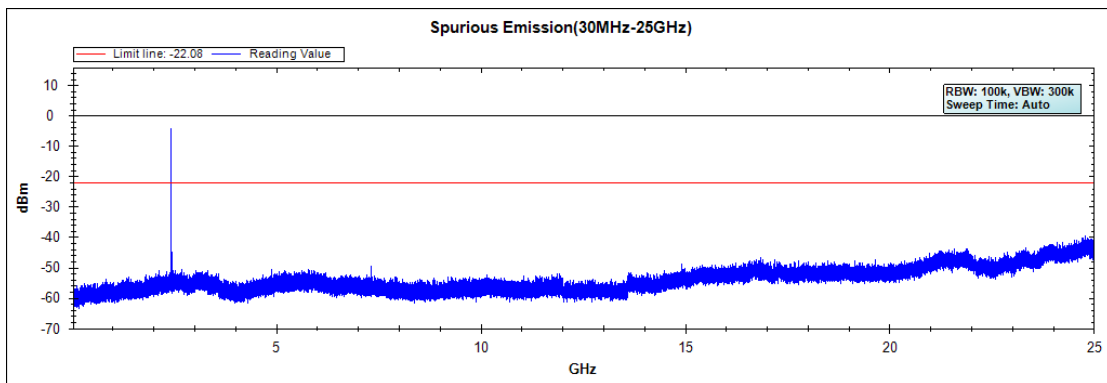

(2480MHz) 30M-25GHz

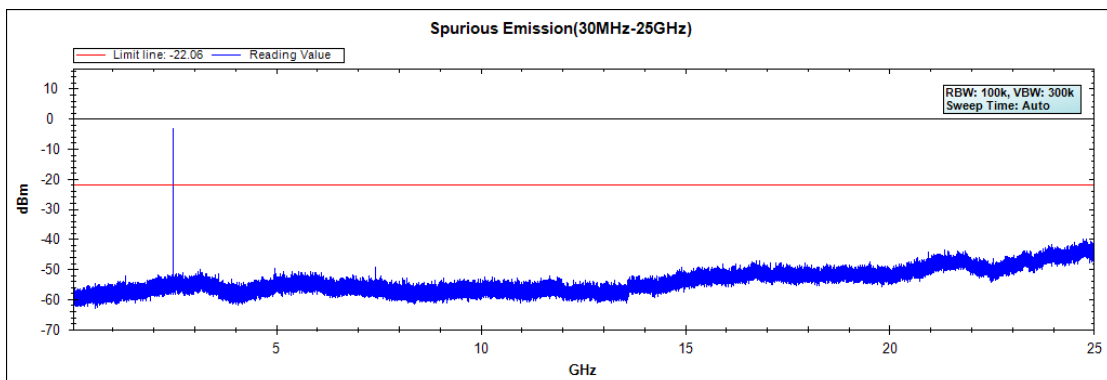

6. Band Edge

6.1. Test Setup

RF Conducted Measurement

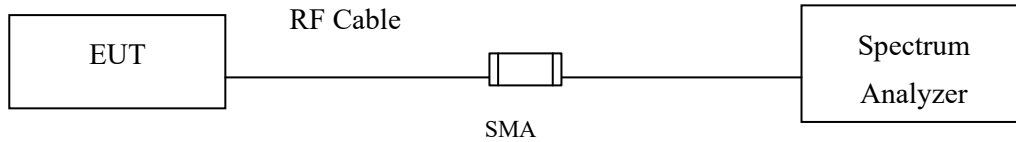

RF Radiated Measurement:

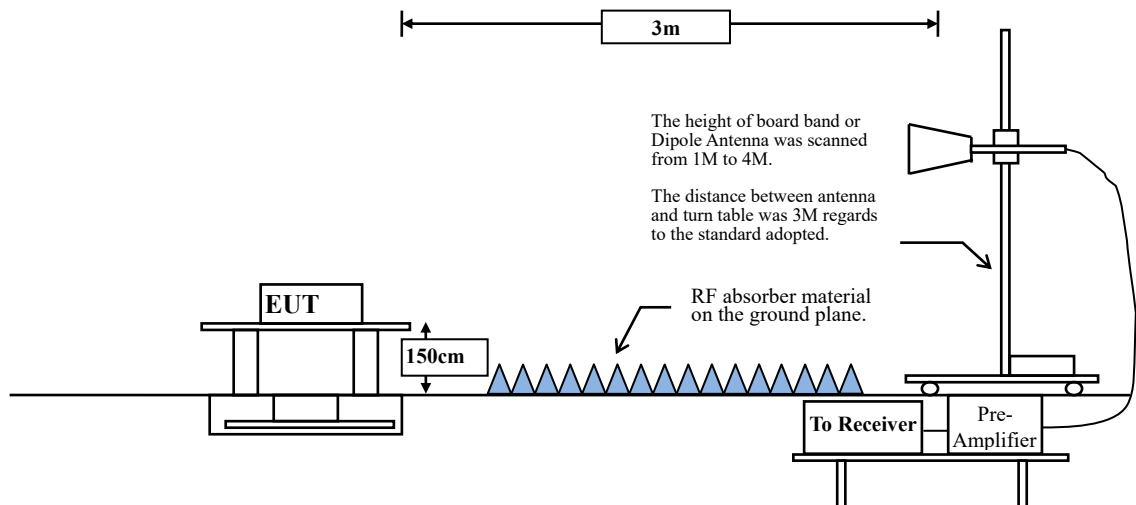

6.2. Limits

Emissions radiated outside of the specified frequency bands, except for harmonics, shall be attenuated by at least 20dB below the level of the fundamental or to the general radiated emission limits in paragraph 15.209, whichever is the lesser attenuation.

6.3. Test Procedure

The EUT was setup according to ANSI C63.10, 2013 and tested according to ANSI C63.10, 2013 for compliance to FCC 47CFR 15.247 requirements.

The EUT is placed on a turn table which is 1.5 meter above ground. The turn table is rotated 360 degrees to determine the position of the maximum emission level. The EUT was positioned such that the distance from antenna to the EUT was 3 meters.

The antenna is scanned from 1 meter to 4 meters to find out the maximum emission level. This is repeated for both horizontal and vertical polarization of the antenna. In order to find the maximum emission, all of the interface cables were manipulated according to ANSI C63.10:2013 on radiated measurement.

RBW and VBW Parameter setting:

According to C63.10 Section 11.12.2.4 Peak measurement procedure

RBW = as specified in Table 1.

VBW \geq 3 x RBW.

Table 1 —RBW as a function of frequency

Frequency	RBW
9-150 kHz	200-300 Hz
0.15-30 MHz	9-10 kHz
30-1000 MHz	100-120 kHz
> 1000 MHz	1 MHz

According to C63.10 Section 11.12.2.5 Average measurement procedure

RBW = 1MHz.

VBW = 10Hz, when duty cycle \geq 98 %

VBW \geq 1/T, when duty cycle < 98 %

(T refers to the minimum transmission duration over which the transmitter is on and is transmitting at its maximum power control level for the tested mode of operation.)

2.4GHz band	Duty Cycle (%)	T (ms)	1/T (Hz)	VBW (Hz)
GFSK	100	--	--	10

Note: Duty Cycle Refer to Section 9.

6.4. Uncertainty

\pm 4.08 dB above 1GHz

\pm 4.22 dB below 1GHz

6.5. Test Result of Band Edge

Product : Gaming Mouse Dongle
 Test Item : Band Edge Data
 Test Site : No.3 OATS
 Test Mode : Mode 1: Transmit (2403MHz)

Horizontal

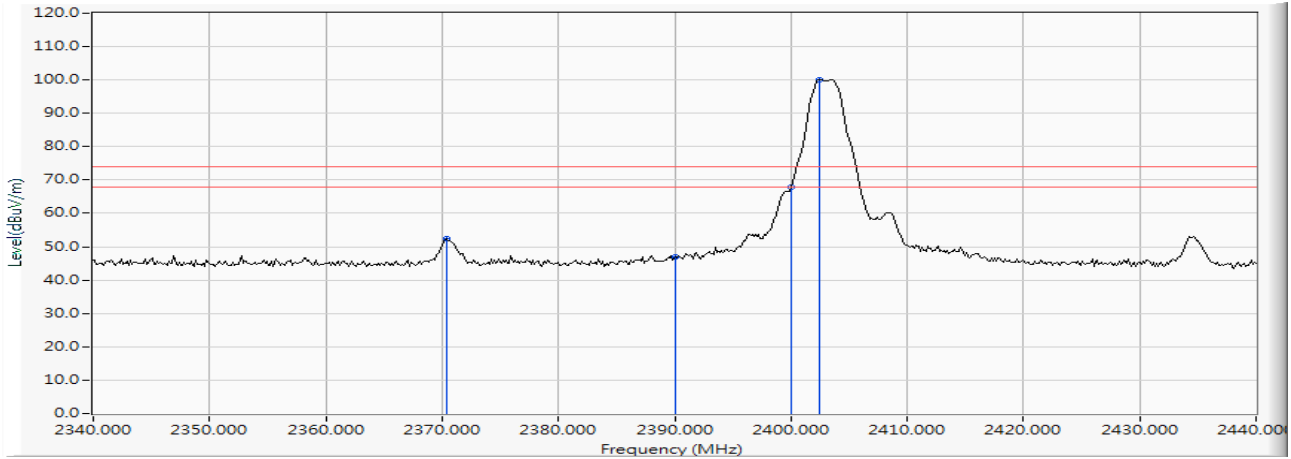

		Frequency (MHz)	Correct Factor (dB)	Reading Level (dBuV)	Measure Level (dBuV/m)	Margin (dB)	Limit (dBuV/m)	Detector Type
1		2370.435	-1.430	53.929	52.500	-21.500	74.000	PEAK
2		2390.000	-1.550	48.568	47.018	-26.982	74.000	PEAK
3		2400.000	-1.612	69.359	67.747	--	--	PEAK
4	*	2402.464	-1.627	101.789	100.162	--	--	PEAK

Note:

1. All readings above 1GHz are performed with peak and/or average measurements as necessary.
2. Measurement Level = Reading Level + Correct Factor.

Product : Gaming Mouse Dongle
 Test Item : Band Edge Data
 Test Site : No.3 OATS
 Test Mode : Mode 1: Transmit (2403MHz)

Horizontal

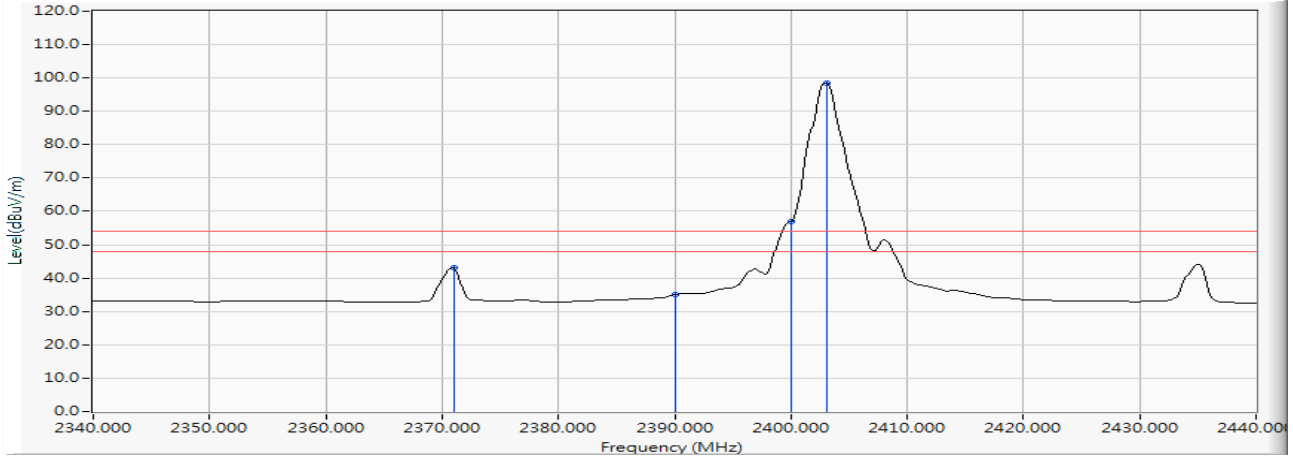

		Frequency (MHz)	Correct Factor (dB)	Reading Level (dBuV)	Measure Level (dBuV/m)	Margin (dB)	Limit (dBuV/m)	Detector Type
1		2371.014	-1.433	44.409	42.976	-11.024	54.000	AVERAGE
2		2390.000	-1.550	36.496	34.946	-19.054	54.000	AVERAGE
3		2400.000	-1.612	58.564	56.952	--	--	AVERAGE
4	*	2403.043	-1.630	100.175	98.545	--	--	AVERAGE

Note:

1. All readings above 1GHz are performed with peak and/or average measurements as necessary.
2. Measurement Level = Reading Level + Correct Factor.

Product : Gaming Mouse Dongle
 Test Item : Band Edge Data
 Test Site : No.3 OATS
 Test Mode : Mode 1: Transmit (2403MHz)

Vertical

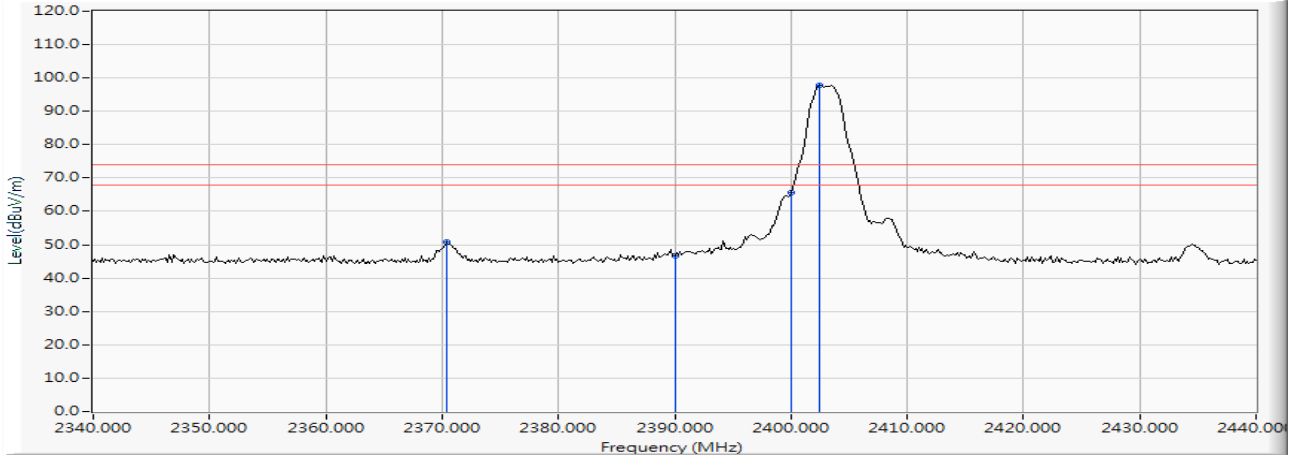

		Frequency (MHz)	Correct Factor (dB)	Reading Level (dBuV)	Measure Level (dBuV/m)	Margin (dB)	Limit (dBuV/m)	Detector Type
1		2370.435	-1.430	52.276	50.847	-23.153	74.000	PEAK
2		2390.000	-1.550	48.230	46.680	-27.320	74.000	PEAK
3		2400.000	-1.612	67.371	65.759	--	--	PEAK
4	*	2402.464	-1.627	99.316	97.689	--	--	PEAK

Note:

1. All readings above 1GHz are performed with peak and/or average measurements as necessary.
2. Measurement Level = Reading Level + Correct Factor.

Product : Gaming Mouse Dongle
 Test Item : Band Edge Data
 Test Site : No.3 OATS
 Test Mode : Mode 1: Transmit (2403MHz)

Vertical

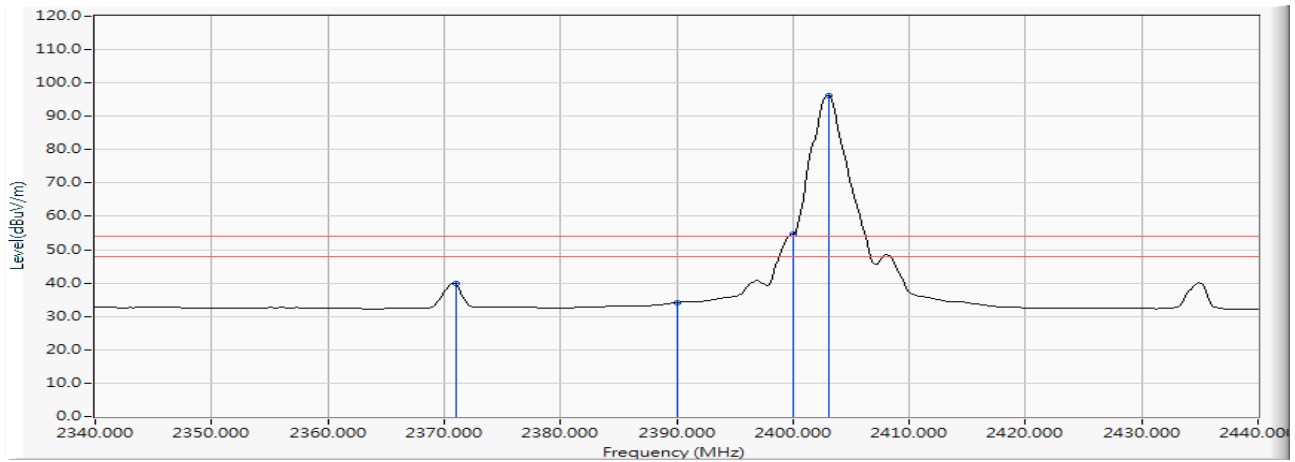

		Frequency (MHz)	Correct Factor (dB)	Reading Level (dBuV)	Measure Level (dBuV/m)	Margin (dB)	Limit (dBuV/m)	Detector Type
1		2371.014	-1.433	41.284	39.851	-14.149	54.000	AVERAGE
2		2390.000	-1.550	35.725	34.175	-19.825	54.000	AVERAGE
3		2400.000	-1.612	56.303	54.691	--	--	AVERAGE
4	*	2403.043	-1.630	97.679	96.049	--	--	AVERAGE

Note:

1. All readings above 1GHz are performed with peak and/or average measurements as necessary.
2. Measurement Level = Reading Level + Correct Factor.

Product : Gaming Mouse Dongle
 Test Item : Band Edge Data
 Test Site : No.3 OATS
 Test Mode : Mode 1: Transmit (2480MHz)

Horizontal

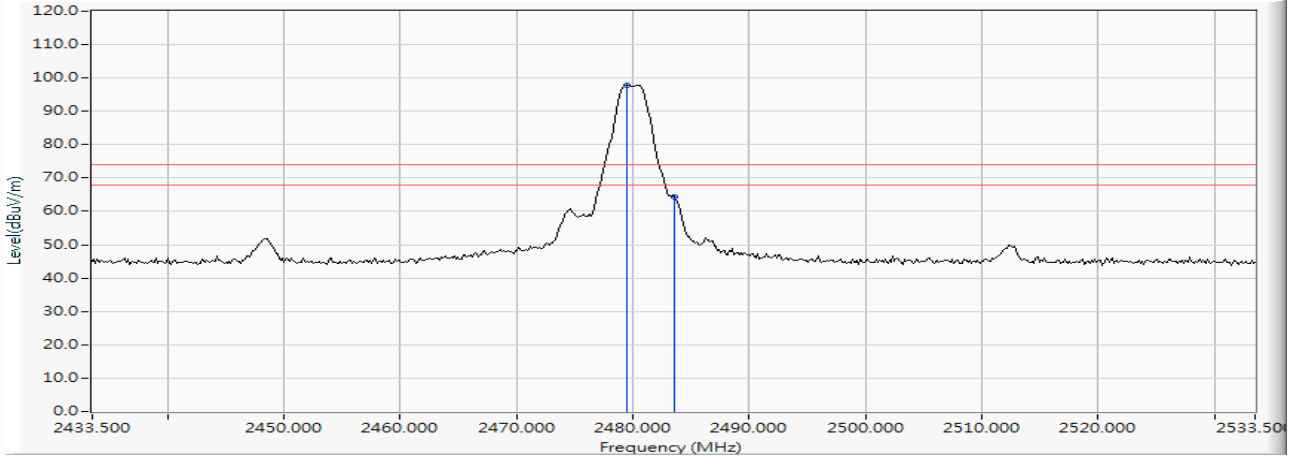

		Frequency (MHz)	Correct Factor (dB)	Reading Level (dBuV)	Measure Level (dBuV/m)	Margin (dB)	Limit (dBuV/m)	Detector Type
1	*	2479.442	-2.102	100.033	97.931	--	--	PEAK
2		2483.500	-2.127	66.345	64.218	-9.782	74.000	PEAK

Note:

1. All readings above 1GHz are performed with peak and/or average measurements as necessary.
2. Measurement Level = Reading Level + Correct Factor.

Product : Gaming Mouse Dongle
 Test Item : Band Edge Data
 Test Site : No.3 OATS
 Test Mode : Mode 1: Transmit (2480MHz)

Horizontal

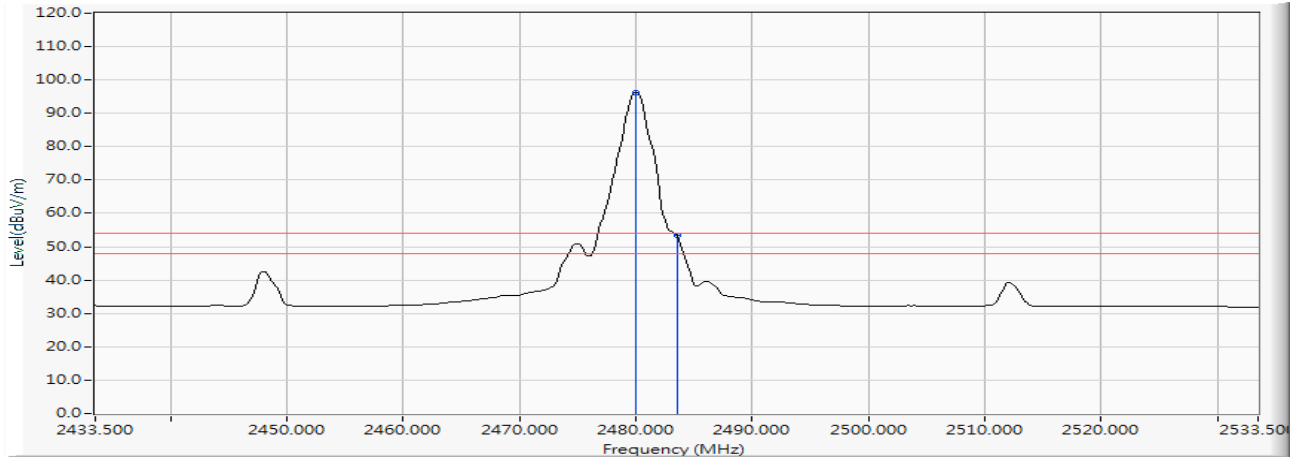

		Frequency (MHz)	Correct Factor (dB)	Reading Level (dBuV)	Measure Level (dBuV/m)	Margin (dB)	Limit (dBuV/m)	Detector Type
1	*	2480.022	35.299	61.040	96.339	--	--	AVERAGE
2		2483.500	-2.127	55.420	53.293	-0.707	54.000	AVERAGE

Note:

1. All readings above 1GHz are performed with peak and/or average measurements as necessary.
2. Measurement Level = Reading Level + Correct Factor.

Product : Gaming Mouse Dongle
 Test Item : Band Edge Data
 Test Site : No.3 OATS
 Test Mode : Mode 1: Transmit (2480MHz)

Vertical

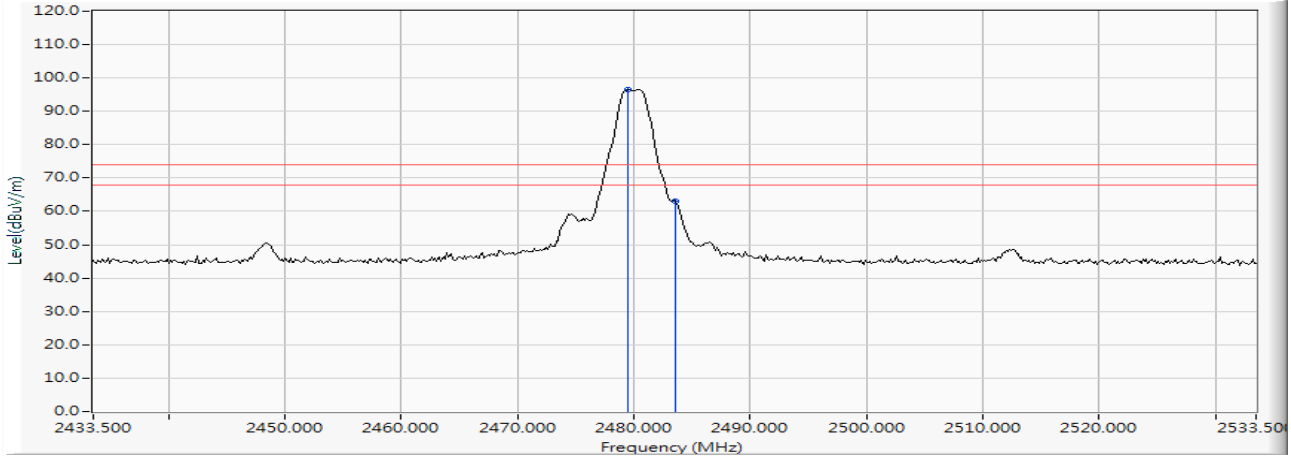

		Frequency (MHz)	Correct Factor (dB)	Reading Level (dBuV)	Measure Level (dBuV/m)	Margin (dB)	Limit (dBuV/m)	Detector Type
1	*	2479.442	-2.102	98.576	96.474	--	--	PEAK
2		2483.500	-2.127	65.117	62.990	-11.010	74.000	PEAK

Note:

1. All readings above 1GHz are performed with peak and/or average measurements as necessary.
2. Measurement Level = Reading Level + Correct Factor.

Product : Gaming Mouse Dongle
 Test Item : Band Edge Data
 Test Site : No.3 OATS
 Test Mode : Mode 1: Transmit (2480MHz)

Vertical

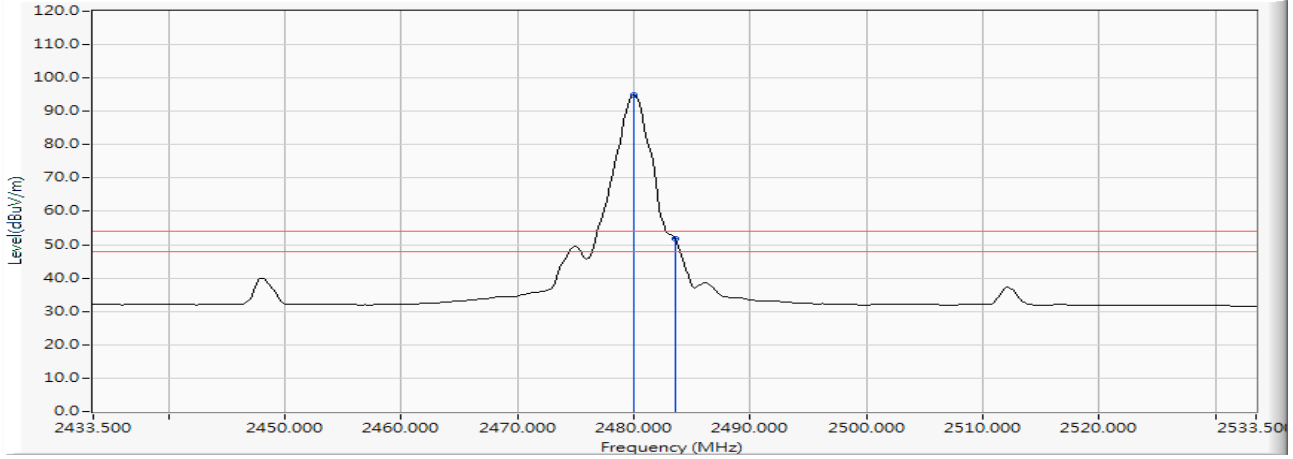

		Frequency (MHz)	Correct Factor (dB)	Reading Level (dBuV)	Measure Level (dBuV/m)	Margin (dB)	Limit (dBuV/m)	Detector Type
1	*	2480.022	-2.105	96.982	94.877	--	--	AVERAGE
2		2483.500	-2.127	54.023	51.896	-2.104	54.000	AVERAGE

Note:

1. All readings above 1GHz are performed with peak and/or average measurements as necessary.
2. Measurement Level = Reading Level + Correct Factor.

7. 6dB Bandwidth

7.1. Test Setup

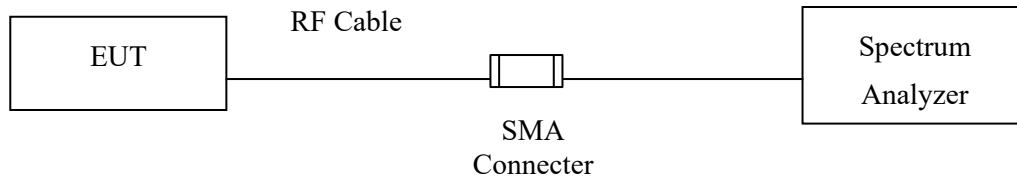

7.2. Limits

The minimum bandwidth shall be at least 500 kHz.

7.3. Test Procedure

The EUT was setup according to ANSI C63.4, 2014; tested according to ANSI C63.10 Section 11.8 for compliance to FCC 47CFR 15.247 requirements.

7.4. Uncertainty

$\pm 283\text{Hz}$

7.5. Test Result of 6dB Bandwidth

Product : Gaming Mouse Dongle
 Test Item : 6dB Bandwidth Data
 Test Site : No.3 OATS
 Test Mode : Mode 1: Transmit (2403MHz)

Channel No.	Frequency (MHz)	Measurement Level (kHz)	Required Limit (kHz)	Result
01	2403.00	1390	>500	Pass

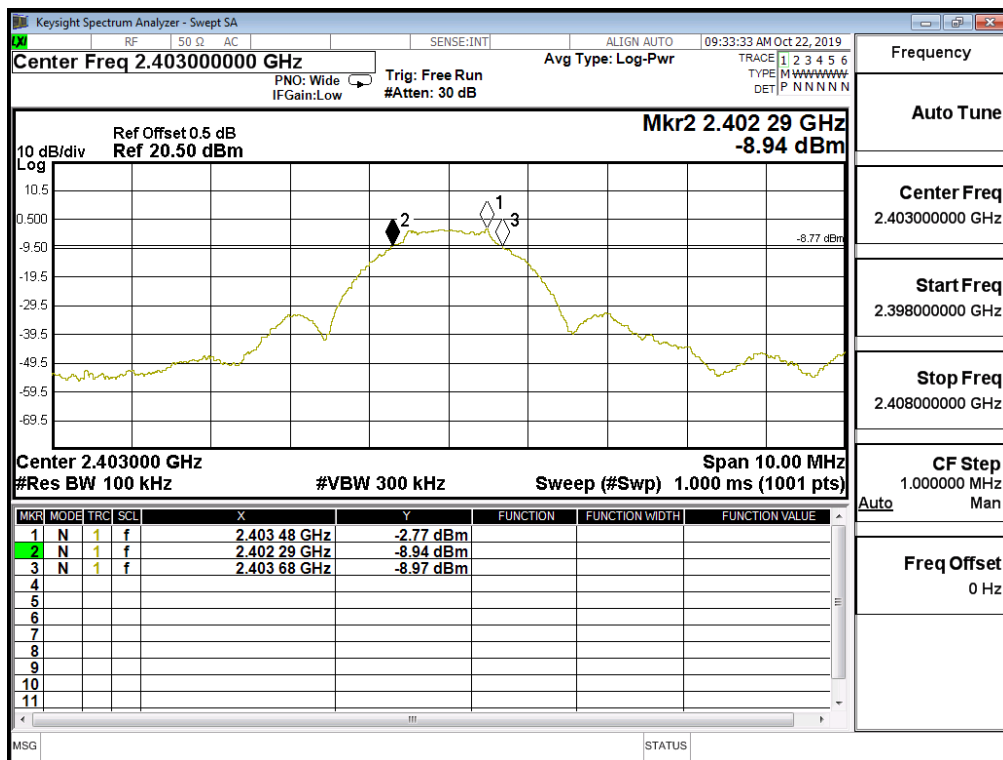

Product : Gaming Mouse Dongle
 Test Item : 6dB Bandwidth Data
 Test Site : No.3 OATS
 Test Mode : Mode 1: Transmit (2440MHz)

Channel No.	Frequency (MHz)	Measurement Level (kHz)	Required Limit (kHz)	Result
38	2440.00	1350	>500	Pass

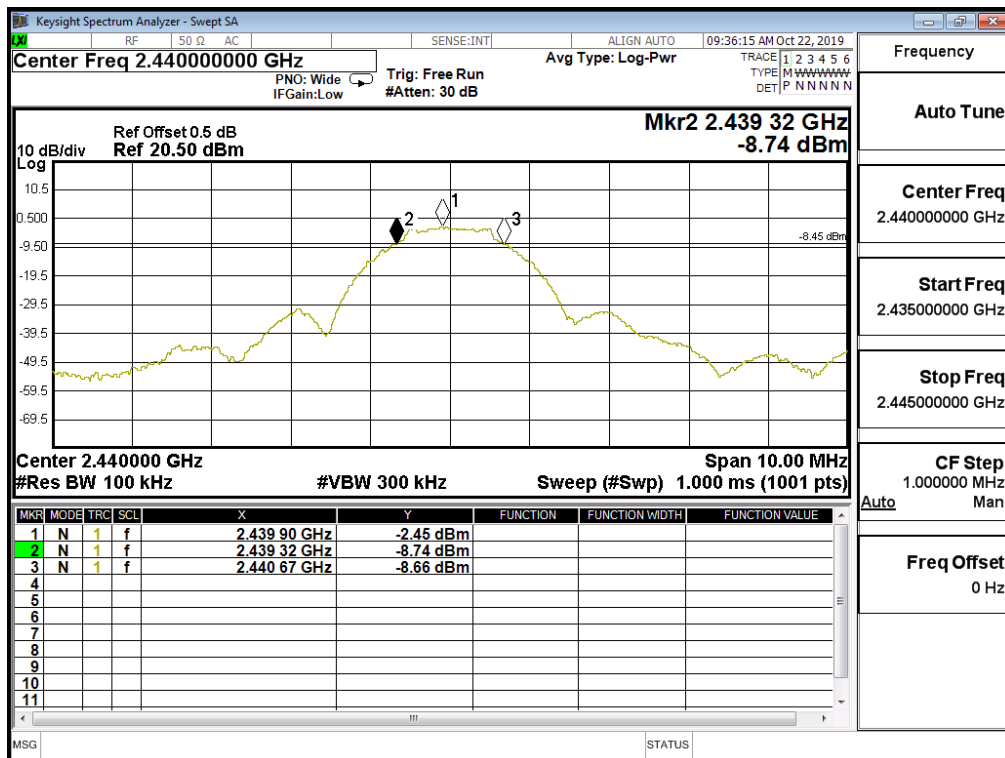

Product : Gaming Mouse Dongle
 Test Item : 6dB Bandwidth Data
 Test Site : No.3 OATS
 Test Mode : Mode 1: Transmit (2480MHz)

Channel No.	Frequency (MHz)	Measurement Level (kHz)	Required Limit (kHz)	Result
78	2480.00	1330	>500	Pass

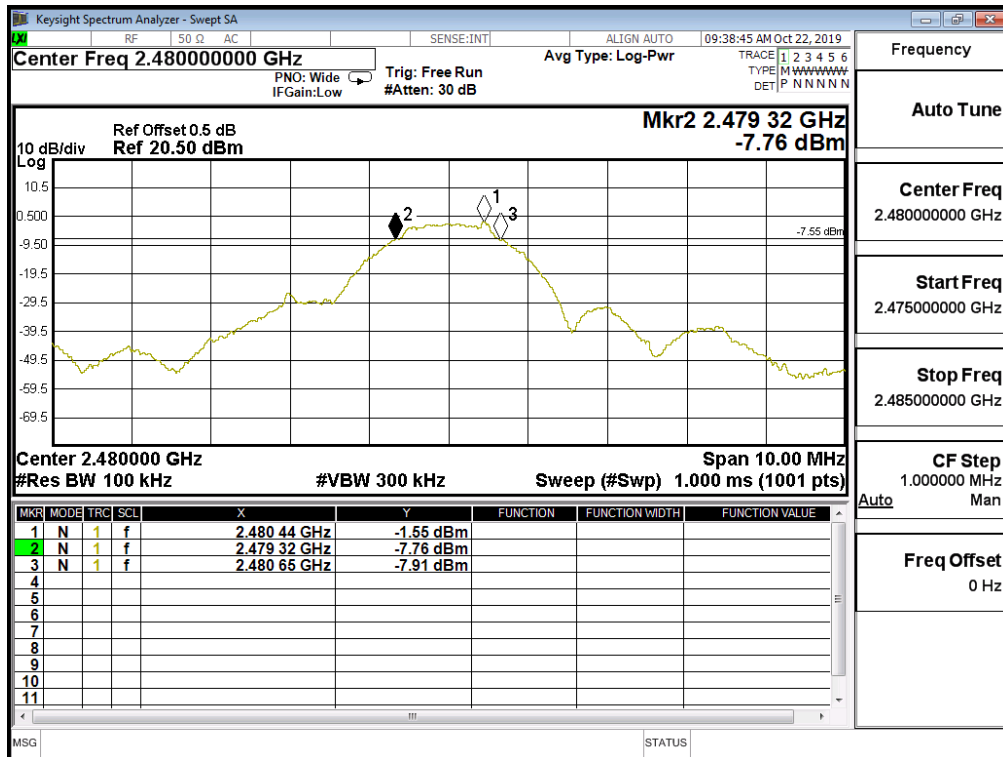

8. Power Density

8.1. Test Setup

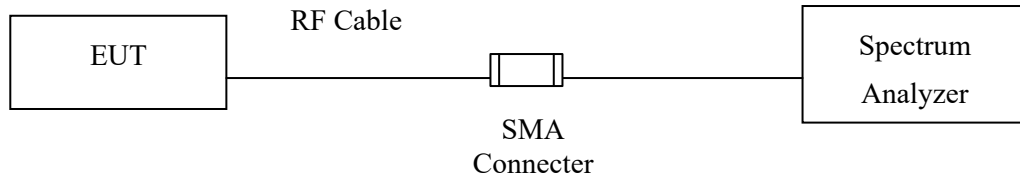

8.2. Limits

The transmitted power density averaged over any 1 second interval shall not be greater +8dBm in any 3kHz bandwidth.

8.3. Test Procedure

The EUT was setup according to ANSI C63.10, 2013; tested according to DTS test procedure of KDB 558074 for compliance to FCC 47CFR 15.247 requirements.

The maximum power spectral density using C63.10 Section 11.10.2 Method PKPSD (peak PSD).

8.4. Uncertainty

± 1.20 dB

8.5. Test Result of Power Density

Product : Gaming Mouse Dongle
 Test Item : Power Density Data
 Test Site : No.3 OATS
 Test Mode : Mode 1: Transmit(2403MHz)

Channel No.	Frequency (MHz)	Measure Level (dBm)	Limit (dBm)	Result
01	2403.00	-2.71	≤ 8dBm	Pass

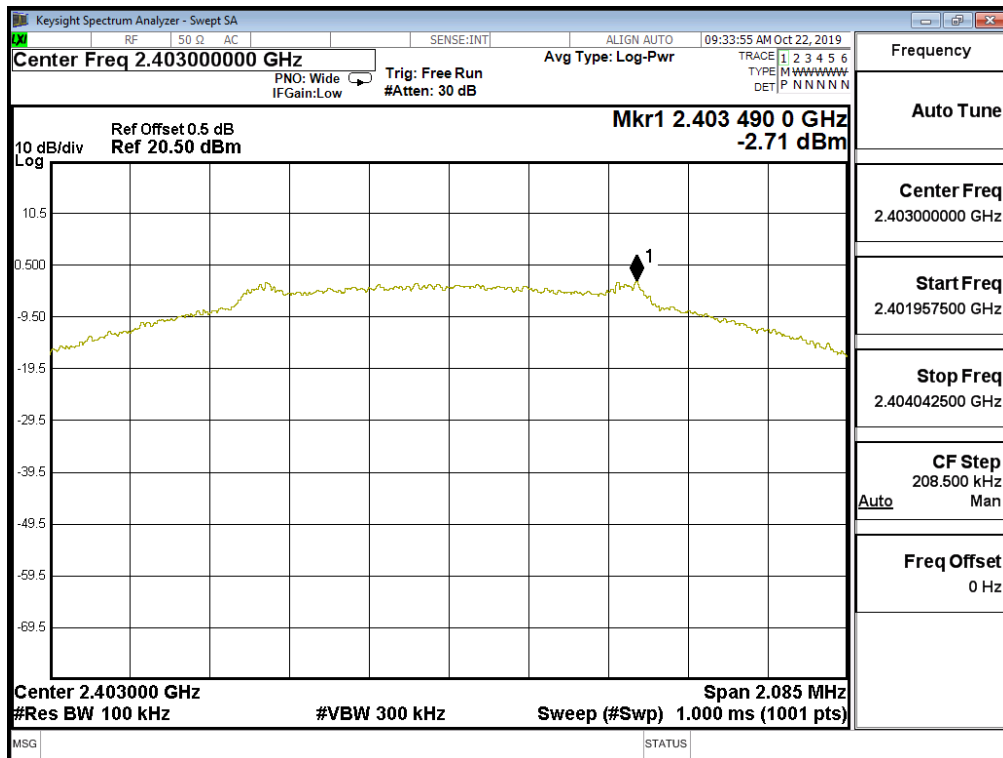

Product : Gaming Mouse Dongle
 Test Item : Power Density Data
 Test Site : No.3OATS
 Test Mode : Mode 1: Transmit (2440MHz)

Channel No.	Frequency (MHz)	Measurement Level (dBm)	Required Limit (dBm)	Result
38	2440.000	-2.08	≤ 8dBm	Pass

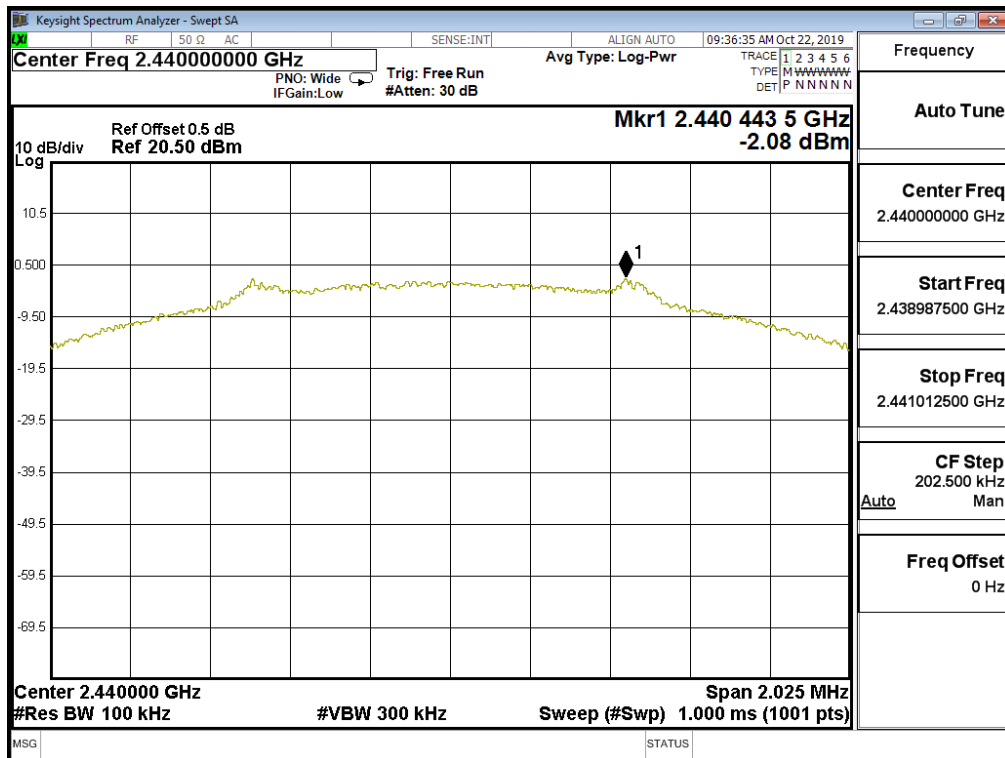

Product : Gaming Mouse Dongle
 Test Item : Power Density Data
 Test Site : No.3 OATS
 Test Mode : Mode 1: Transmit (2480MHz)

Channel No.	Frequency (MHz)	Measurement Level (dBm)	Required Limit (dBm)	Result
78	2480.00	-2.06	≤ 8dBm	Pass

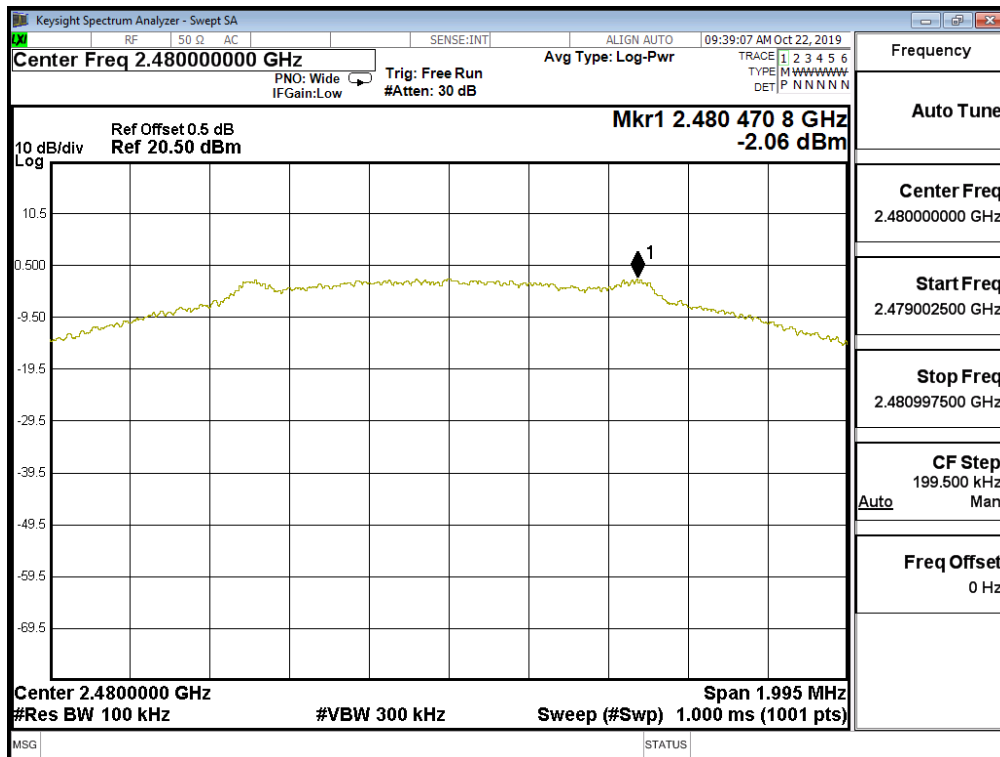

9. Duty Cycle

9.1. Test Setup

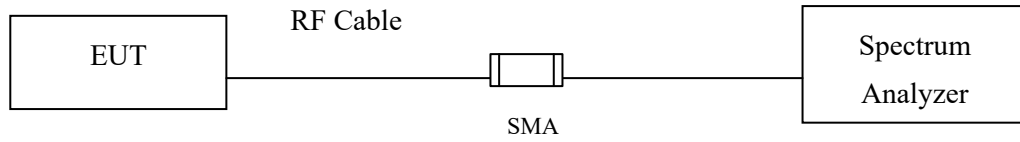

9.2. Test Procedure

The EUT was setup according to ANSI C63.10 2013; tested according to ANSI C63.10 2013 for compliance to FCC 47CFR 15.247 requirements.

9.3. Uncertainty

$\pm 2.31\text{msec}$

9.4. Test Result of Duty Cycle

Product : Gaming Mouse Dongle
 Test Item : Duty Cycle
 Test Mode : Mode 1: Transmit

Duty Cycle Formula:

$$\text{Duty Cycle} = \text{Ton} / (\text{Ton} + \text{Toff})$$

$$\text{Duty Factor} = 10 \text{ Log} (1/\text{Duty Cycle})$$

Results:

2.4GHz band	Ton (ms)	Ton + Toff (ms)	Duty Cycle (%)	Duty Factor (dB)
GFSK	--	--	100	--

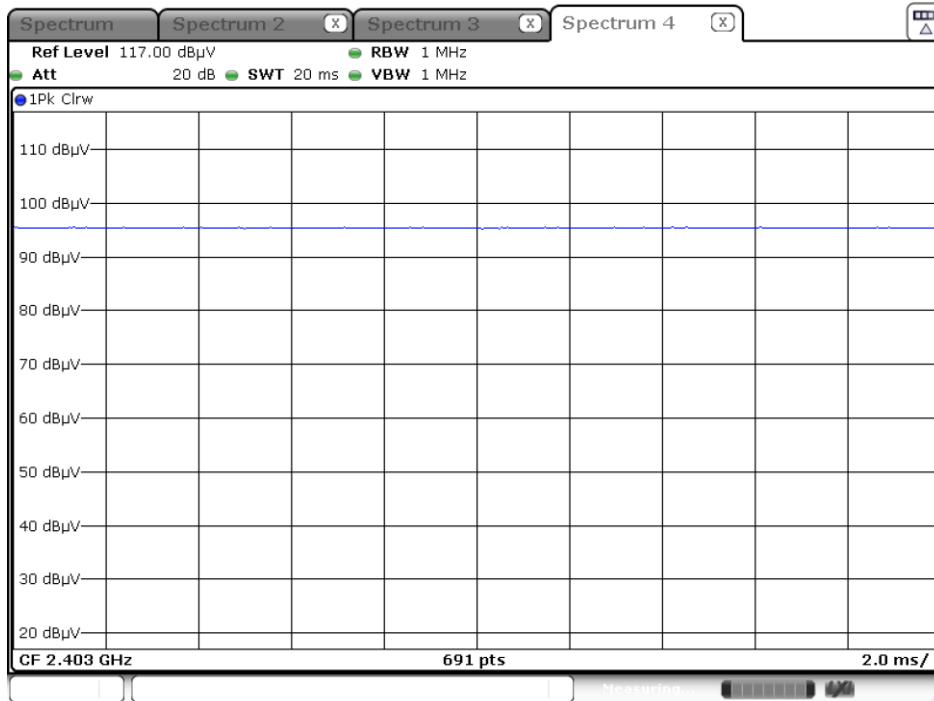

Date: 21.OCT.2019 09:32:22

10. EMI Reduction Method During Compliance Testing

No modification was made during testing.