

RF parts outside the RF Shielding

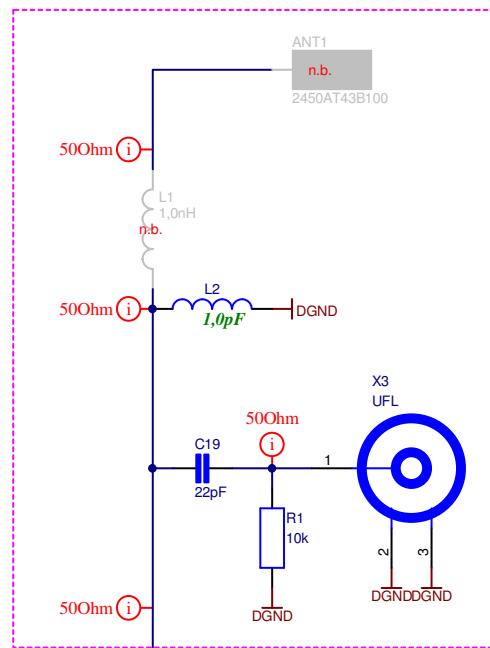

Distance between C3 and B1-Pad1 = 0.65mm

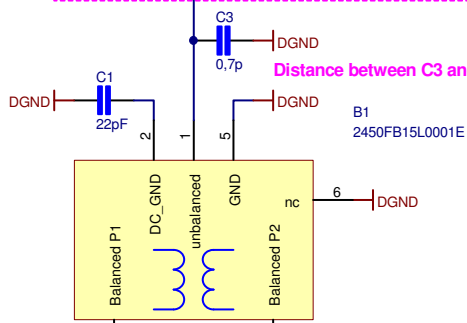

Layout notes:
connect only AVSS pins directly to paddle (33)

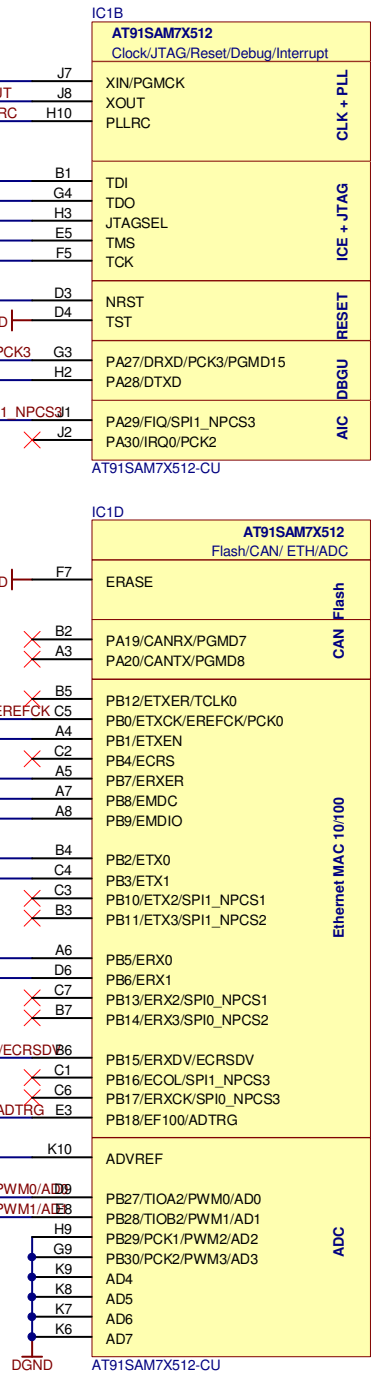
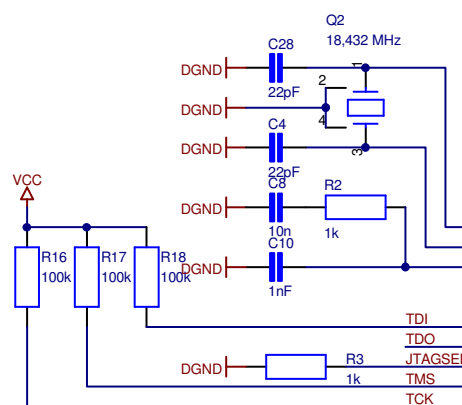
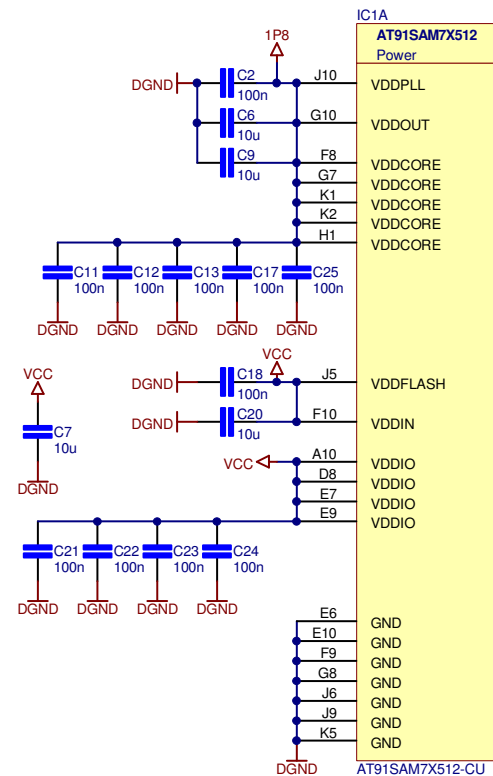
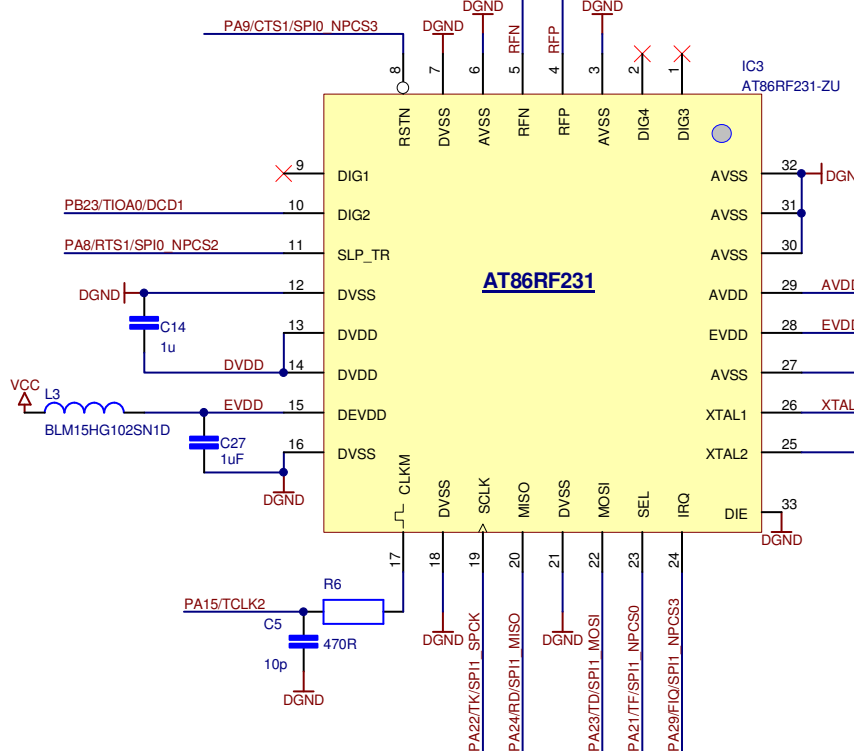

Port Pins needed for RMII:
- EREFCK
- ETXEN
- ETX0
- ETX1
- ECRSDV
- ERX0
- ERX1
- ERXER
- EMDC
- EMDIO
- EF100

Hardware Identification:

	PA7	PA25	PA26
Rev00	1	1	1
Rev01	1	1	0
Rev02	1	0	1

1: open
0: GND

