



FCC 47 CFR PART 15 SUBPART C AND ANSI C63.4: 2003

TEST REPORT

For

Air Dongle

Model : UD08b



Brand Name : cideko

Test Report Number:

T100811404-RP1

Issued for

Holy Investment Co., Ltd.

1F., No.2, Lane 25, Yong-an 2nd St., Yongkang City, Tainan County 710, Taiwan

Issued by

Compliance Certification Services Inc.

Tainan Lab.

**No. 8, Jiu Cheng Ling, Jiaokeng Village, Sinhua
Township, Tainan Hsien 712, Taiwan R.O.C.**

TEL: 886-6-580-2201

FAX: 886-6-580-2202

Issued Date: September 13, 2010



***Note:** This report shall not be reproduced except in full, without the written approval of Compliance Certification Services Inc. This document may be altered or revised by Compliance Certification Services Inc. personnel only, and shall be noted in the revision section of the document.*



REVISION HISTORY

Rev.	Issue Date	Revisions	Effect Page	Revised By
00	September 13, 2010	Initial Issue	ALL	Leah Peng



TABLE OF CONTENTS

1. TEST RESULT CERTIFICATION	4
2. EUT DESCRIPTION	5
3. TEST METHODOLOGY	6
3.1 EUT CONFIGURATION	6
3.2 EUT EXERCISE	6
3.3 GENERAL TEST PROCEDURES	6
3.4 FCC PART 15.205 RESTRICTED BANDS OF OPERATIONS	7
3.5 DESCRIPTION OF TEST MODES	7
4. INSTRUMENT CALIBRATION	8
4.1 MEASURING INSTRUMENT CALIBRATION	8
4.2 MEASUREMENT EQUIPMENT USED	8
5. FACILITIES AND ACCREDITATIONS	9
5.1 FACILITIES	9
5.2 EQUIPMENT	9
5.3 LABORATORY ACCREDITATIONS LISTINGS	9
5.4 TABLE OF ACCREDITATIONS AND LISTINGS	10
6. SETUP OF EQUIPMENT UNDER TEST	11
6.1 SETUP CONFIGURATION OF EUT	11
6.2 SUPPORT EQUIPMENT	11
7. FCC PART 15.249 REQUIREMENTS	12
7.1 20 DB BANDWIDTH	12
7.2 BAND EDGES MEASUREMENT	15
7.3 SPURIOUS EMISSION	21
7.4 POWERLINE CONDUCTED EMISSIONS	32
8. APPENDIX I PHOTOGRAPHS OF TEST SETUP	35
APPENDIX II PHOTOGRAPHS OF E.U.T	A1-1



1. TEST RESULT CERTIFICATION

Product:	Air Dongle
Model:	UD08b
Brand Name:	
Applicant:	Holy Investment Co., Ltd. 1F., No.2, Lane 25, Yong-an 2nd St., Yongkang City, Tainan County 710, Taiwan
Manufacturer:	Jow Tong Technology CO., LTD. 46, Lane 337, Chung Cheng Rd., Yung Kang City, Tainan County 710, Taiwan, R.O.C.
Tested:	September 7, 2010 ~ September 9, 2010

APPLICABLE STANDARDS	
STANDARD	TEST RESULT
FCC Part 15 Subpart C : 2008 AND ANSI C63.4 : 2003	No non-compliance noted

Jeter Wu
Assistant Manager

Eric Huang
Assistant Section Manager



2. EUT DESCRIPTION

Product	Air Dongle
Model Number	UD08b
Brand Name	 cideko
Frequency Range	2403 ~ 2475MHz
Transmit Peak Power	94dBuV (-13dBm)
Channel Spacing	TX Mode: 1.5MHz
Number of Channels	49 Channels 2403 , 2404.5 , 2406 , 2407.5, 2409 , 2410.5 , 2412 , 2413.5 , 2415 , 2416.5 , 2418 , 2419.5 , 2421 , 2422.5 , 2424 , 2425.5 , 2427 , 2428.5 , 2430 , 2431.5 , 2433 , 2434.5 , 2436 , 2437.5 , 2439 , 2440.5 , 2442 , 2443.5 , 2445 , 2446.5 , 2448 , 2449.5 , 2451 , 2452.5 , 2454 , 2455.5 , 2457 , 2458.5 , 2460 , 2461.5 , 2463 , 2464.5 , 2466 , 2467.5 , 2469 , 2470.5 , 2472 , 2473.5 , 2475MHz
Transmit Data Rate	100kbps
Modulation Technique	MSK
Frequency Selection	By software / firmware
Antenna Type	Antenna (1)TX&RX: Manufacture: Yageo Taiwan/High Frequency Ceramic Department Model: CAN4311 881 05 245 3K, Type: Chip Antenna, Gain: 3dBi
Power Source	5VDC
Temperature Range	0 ~ +55°C

Remark:

1. The sample selected for test was production product and was provided by manufacturer.
2. This submittal(s) (test report) is intended for FCC ID: **XV3UD08B** filing to comply with Section 15.107, 15.109, 15.207, 15.209, 15.249 (FCC Part 15, Subpart C Rules.)
3. According to customer declaration, the Air Dongle will assembly the Air Keyboard Conqueror for sale.



3. TEST METHODOLOGY

The tests documented in this report were performed in accordance with ANSI C63.4: 2003 and FCC CFR 47 Part 15.207, 15.209 and 15.249.

3.1 EUT CONFIGURATION

The EUT configuration for testing is installed on RF field strength measurement to meet the Commissions requirement and operating in a manner that intends to maximize its emission characteristics in a continuous normal application.

3.2 EUT EXERCISE

The EUT was operated in the engineering mode to fix the TX frequency that was for the purpose of the measurements.

According to its specifications, the EUT must comply with the requirements of the Section 15.207, 15.209, 15.249 under the FCC Rules Part 15 Subpart C.

3.3 GENERAL TEST PROCEDURES

Conducted Emissions

The EUT is placed on the turntable, which is 0.8 m above ground plane. According to the requirements in Section 13.1.4.1 of ANSI C63.4: 2003 Conducted emissions from the EUT measured in the frequency range between 0.15 MHz and 30MHz using CISPR Quasi-peak and average detector modes.

Radiated Emissions

The EUT is placed on a turn table, which is 0.8 m above ground plane. The turntable shall rotate 360 degrees to determine the position of maximum emission level. EUT is set 3m away from the receiving antenna, which varied from 1m to 4m to find out the highest emission. And also, each emission was to be maximized by changing the polarization of receiving antenna both horizontal and vertical. In order to find out the maximum emissions, exploratory radiated emission measurements were made according to the requirements in Section 13.1.4.1 of ANSI C63.4: 2003.



3.4 FCC PART 15.205 RESTRICTED BANDS OF OPERATIONS

(a) Except as shown in paragraph (d) of this section, only spurious emissions are permitted in any of the frequency bands listed below:

MHz	MHz	MHz	GHz
0.090 - 0.110	16.42 - 16.423	399.9 - 410	4.5 - 5.15
¹ 0.495 - 0.505	16.69475 - 16.69525	608 - 614	5.35 - 5.46
2.1735 - 2.1905	16.80425 - 16.80475	960 - 1240	7.25 - 7.75
4.125 - 4.128	25.5 - 25.67	1300 - 1427	8.025 - 8.5
4.17725 - 4.17775	37.5 - 38.25	1435 - 1626.5	9.0 - 9.2
4.20725 - 4.20775	73 - 74.6	1645.5 - 1646.5	9.3 - 9.5
6.215 - 6.218	74.8 - 75.2	1660 - 1710	10.6 - 12.7
6.26775 - 6.26825	108 - 121.94	1718.8 - 1722.2	13.25 - 13.4
6.31175 - 6.31225	123 - 138	2200 - 2300	14.47 - 14.5
8.291 - 8.294	149.9 - 150.05	2310 - 2390	15.35 - 16.2
8.362 - 8.366	156.52475 -	2483.5 - 2500	17.7 - 21.4
8.37625 - 8.38675	156.52525	2655 - 2900	22.01 - 23.12
8.41425 - 8.41475	156.7 - 156.9	3260 - 3267	23.6 - 24.0
12.29 - 12.293	162.0125 - 167.17	3332 - 3339	31.2 - 31.8
12.51975 - 12.52025	167.72 - 173.2	3345.8 - 3358	36.43 - 36.5
12.57675 - 12.57725	240 - 285	3600 - 4400	(²)
13.36 - 13.41	322 - 335.4		

¹ Until February 1, 1999, this restricted band shall be 0.490-0.510 MHz.

² Above 38.6

(b) Except as provided in paragraphs (d) and (e), the field strength of emissions appearing within these frequency bands shall not exceed the limits shown in Section 15.209. At frequencies equal to or less than 1000 MHz, compliance with the limits in Section 15.209 shall be demonstrated using measurement instrumentation employing a CISPR quasi-peak detector. Above 1000 MHz, compliance with the emission limits in Section 15.209 shall be demonstrated based on the average value of the measured emissions. The provisions in Section 15.35 apply to these measurements.

3.5 DESCRIPTION OF TEST MODES

The EUT (model: UD08b) had been tested under operating condition.

After verification, all tests were carried out with the worst case test modes as shown below except radiated spurious emission below 1GHz, which worst case was in normal link mode only, and powerline conducted emission below 30MHz, which worst case was in normal link mode .

All tests were carried out with the worst case test modes as shown below except radiated spurious emission below 1GHz, which worst case was in normal link mode .

Channel Low (2403MHz), Channel Mid (2439MHz) and Channel High (2475MHz) were chosen for the RF final testing.

Note : The field strength of spurious emission was measured in the following position: EUT stand-up position(Z axis), lie-down position(X,Y axis). The worst emission was found in stand-up position(X axis) and the worst case was recorded.



4. INSTRUMENT CALIBRATION

4.1 MEASURING INSTRUMENT CALIBRATION

The measuring equipment, which was utilized in performing the tests documented herein, has been calibrated in accordance with the manufacturer's recommendations for utilizing calibration equipment, which is traceable to recognized national standards.

4.2 MEASUREMENT EQUIPMENT USED

Equipment Used for Emissions Measurement

Open Area Test Site # 6				
Name of Equipment	Manufacturer	Model	Serial Number	Calibration Due
TYPE N COAXIAL CABLE	SUHNER	CHA9513	6	AUG. 31, 2011
BI-LOG Antenna	Sunol	JB1	A070506-2	NOV. 12, 2010
LOOP ANTENNA	EMCO	6502	8905-2356	JUN. 10, 2011
Pre-Amplifier	HP	8447F	2944A03817	AUG. 31, 2011
EMI Receiver	R&S	ESVS10	833206/012	MAY 10, 2011
RF Cable	SUHNER	SUCOFLEX104PEA	20520/4PEA	NOV. 10, 2010
Horn Antenna	Com-Power	AH-118	071032	DEC. 29, 2010
Spectrum Analyzer	R&S	FSEK 30	835253/002	JUL. 14, 2011
Pre-Amplifier	MITEQ	AFS44-00108650-42-10P-44	1205908	NOV. 10, 2010
Turn Table	Yo Chen	001	-----	N.C.R.
Antenna Tower	AR	TP1000A	309874	N.C.R.
Controller	CT	SC101	-----	N.C.R.
RF Swiith	E-INSTRUMENT TELH LTD	ERS-180A	EC1204141	N.C.R
Power Meter	Anritsu	ML2487A	6K00003888	MAY 11, 2011
Power Sensor	Anritsu	MA2491A	33265	MAY 10, 2011

Remark: Each piece of equipment is scheduled for calibration once a year.

Conducted Emission room #1				
Name of Equipment	Manufacturer	Model	Serial Number	Calibration Due
L.I.S.N.	SCHWARZBECK	NNLK 8121	8121-308	MAR. 09, 2011
	Rohde & Schwarz	ESH 3-Z5	840062/021	NOV. 29, 2010
TEST RECEIVER	Rohde & Schwarz	ESCS 30	100348	JUL. 13, 2011
BNC COAXIAL CABLE	CCS	BNC50	11	AUG. 26, 2011
Test S/W	e-3 (5.04211c) R&S (2.27)			



5. FACILITIES AND ACCREDITATIONS

5.1 FACILITIES

All measurement facilities used to collect the measurement data are located at

☒ No. 8, Jiu Cheng Ling, Jiaokeng Village, Sinhua Township, Tainan Hsien 712, Taiwan R.O.C.

The sites are constructed in conformance with the requirements of ANSI C63.7:1992, ANSI C63.4 : 2003 and CISPR Publication 22.

5.2 EQUIPMENT

Radiated emissions are measured with one or more of the following types of linearly polarized antennas: tuned dipole, biconical, log periodic, bi-log, and/or ridged waveguide, horn. Spectrum analyzers with preselectors and quasi-peak detectors are used to perform radiated measurements.

Conducted emissions are measured with Line Impedance Stabilization Networks and EMI Test Receivers.

Calibrated wideband preamplifiers, coaxial cables, and coaxial attenuators are also used for making measurements.





All receiving equipment conforms to CISPR Publication 16-1, "Radio Interference Measuring Apparatus and Measurement Methods."

5.3 LABORATORY ACCREDITATIONS LISTINGS

The test facilities used to perform radiated and conducted emissions tests are accredited by Taiwan Accreditation Foundation for the specific scope of accreditation under Lab Code: 1109 to perform Electromagnetic Interference tests according to FCC PART 15 AND CISPR 22 requirements. No part of this report may be used to claim or imply product endorsement by TAF or any agency of the Government. In addition, the test facilities are listed with Federal Communications Commission (registration no: TW-1037).



5.4 TABLE OF ACCREDITATIONS AND LISTINGS

Country	Agency	Scope of Accreditation	Logo
USA	FCC	3/10 meter Open Area Test Sites to perform FCC Part 15/18 measurements	 TW-1037
Japan	VCCI	3/10 meter Open Area Test Sites and conducted test sites to perform radiated/conducted measurements	 C-2882 R-2635
Taiwan	TAF	CISPR 11, FCC METHOD-47 CFR Part 18, EN 55011, EN 60601-1-2, CISPR 22, CNS 13438, EN 55022, EN 55024, AS/NZS CISPR 22 CISPR 14, EN 55014-1, EN 55014-2, CNS 13783-1, CISPR 22, CNS 13439, EN 55013, FCC Method-47 CFR Part 15 Subpart B, IC ICES-003, VCCI V-3 & V-4 FCC Method-47 CFR Part 15 Subpart C and ANSI C63.4, LP 0002 EN / IEC 61000-4-2 / -3 / -4 / -5 / -6 / -8 / -11 EN 61000-3-2, EN 61000-3-3 EN 61000-6-3, EN 61000-6-1, AS/NZS 4251.1, EN 61000-6-4, EN 61000-6-2, AS/NZS 4251.2, EN 61204-3, EN 50130-4, EN 62040-2, EN 50371, EN 50385, AS/NZS 4268, ETSI EN 300 386 ETSI EN 300 328, ETSI EN 301 489-1/-3/-9/-17 ETSI EN 301 893, ETSI EN 300 220-2/-1 ETSI EN 300 440-2/-1 ETSI EN 301 357-2/-1 RSS-310, RSS-210 Issue 7, RSS-Gen Issue 2	
Taiwan	BSMI	CNS 13438, CNS 13783-1, CNS13439	 SL2-IN-E-0039 SL2-R1/R2-0039 SL2-A1-E-0039
Canada	Industry Canada	RSS210, Issue 7	 IC 2324H-1

* No part of this report may be used to claim or imply product endorsement by TAF or any agency of the US Government.



6. SETUP OF EQUIPMENT UNDER TEST

6.1 SETUP CONFIGURATION OF EUT

[Below 1GHz]

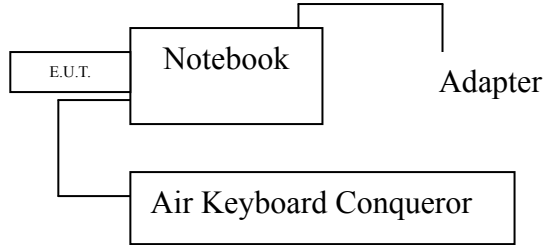

[Above 1GHz]

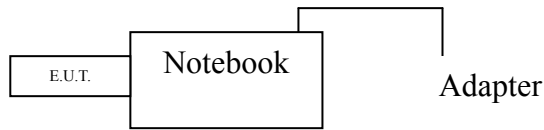

6.2 SUPPORT EQUIPMENT

[Below 1GHz]

No.	Product	Manufacturer	Model No.	Certify No.	Signal cable
1.	Notebook	IBM	T43	DOC	Power cable, unshd, 1.6m
2.	Air Keyboard Conqueror	cideko	AK08b	XV3AK08B	USB cable, shd, 1.2m

No.	Signal cable description				
A	-	-	-	-	-

[Above 1GHz]

No.	Product	Manufacturer	Model No.	Certify No.	Signal cable
1	N/A	-----	-----	-----	-----

No.	Signal cable description				
A	N/A	-----	-----	-----	-----

Remark:

1. All the equipment/cables were placed in the worst-case configuration to maximize the emission during the test.
2. Grounding was established in accordance with the manufacturer's requirements and conditions for the intended use.



7. FCC PART 15.249 REQUIREMENTS

7.1 20 DB BANDWIDTH

LIMIT

None; for reporting purposes only.

Test Configuration

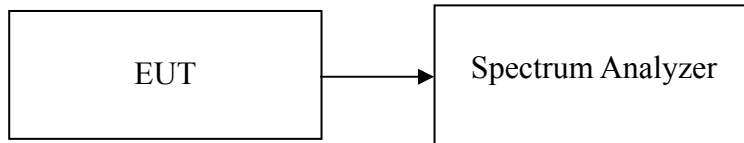

TEST PROCEDURE

1. Place the EUT on the table and set it in the transmitting mode.
2. Remove the antenna from the EUT and then connect a low loss RF cable from the antenna port to the spectrum analyzer.
3. Set the spectrum analyzer as RBW=10kHz, VBW = RBW, Span = 2MHz, Sweep = auto.
4. Mark the peak frequency and 20dB (upper and lower) frequency.
5. Repeat until all the rest channels are investigated.

TEST RESULTS

No non-compliance noted

Test Data

Channel	Frequency (MHz)	20 dB Bandwidth Chain0 (KHz)
CH Low	2403	482.96
CH Mid	2439	492.98
CH High	2475	486.97



Test Plot

CH Low

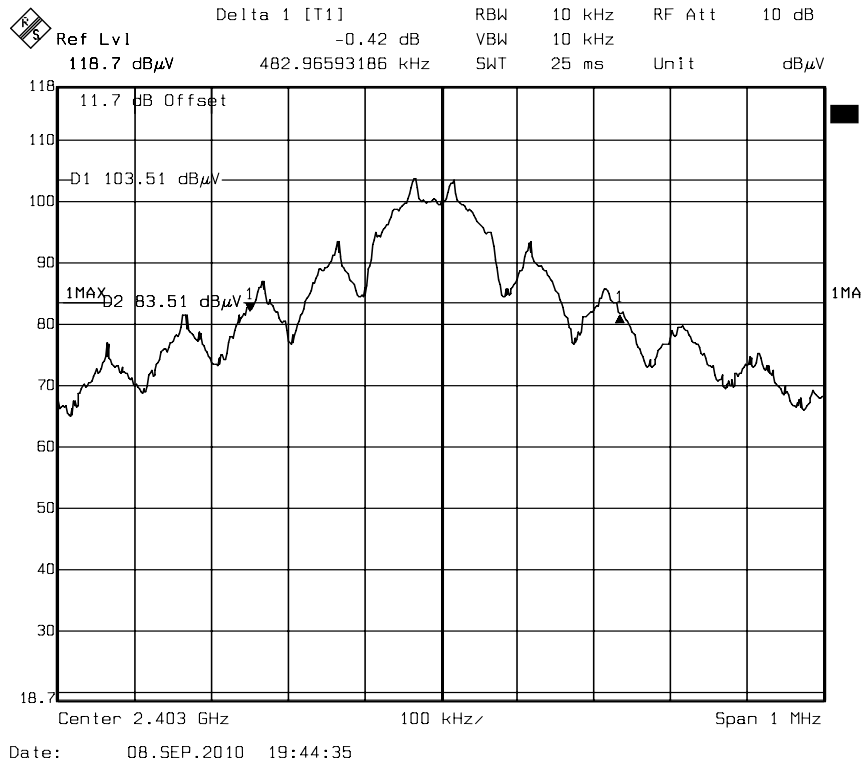

CH Mid

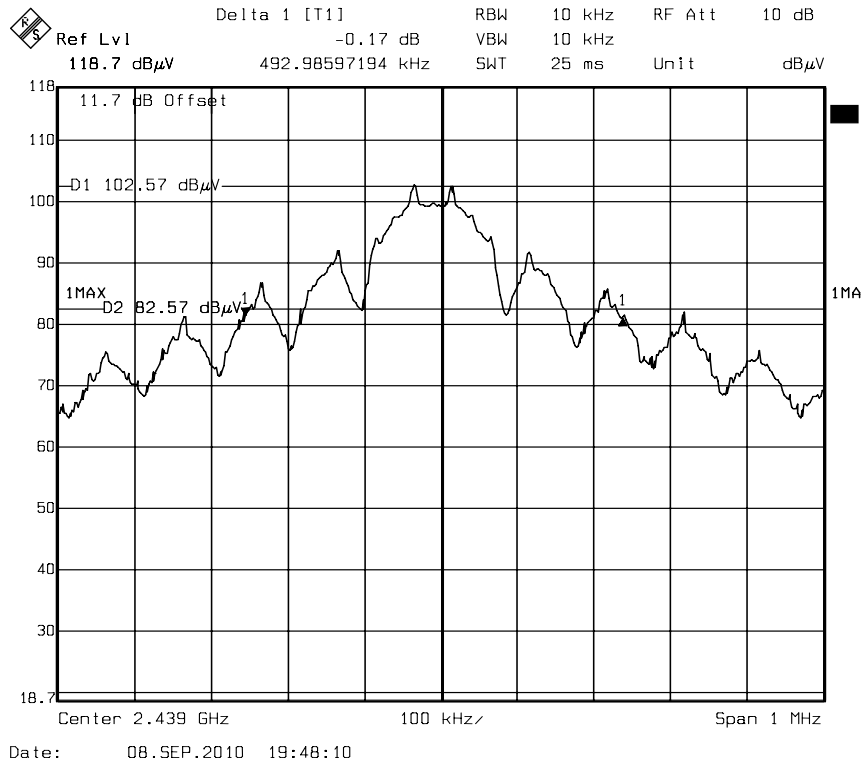



CH High

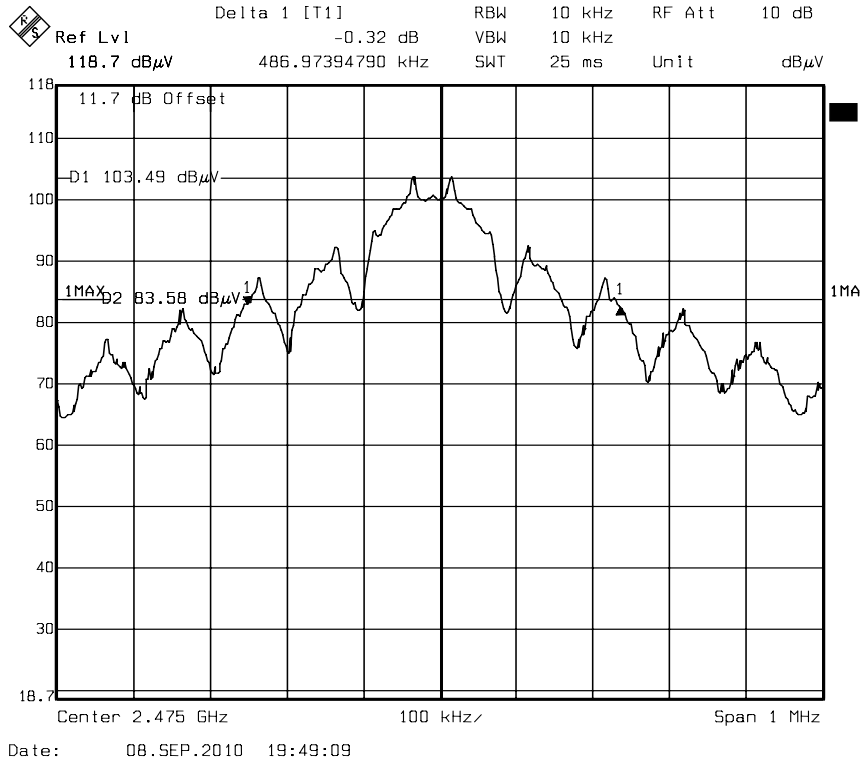



7.2 BAND EDGES MEASUREMENT

LIMIT

1. In the above emission table, the tighter limit applies at the band edges.

Frequency (MHz)	Field Strength ($\mu\text{V}/\text{m}$ at 3-meter)	Field Strength ($\text{dB}\mu\text{V}/\text{m}$ at 3-meter)
30-88	100	40
88-216	150	43.5
216-960	200	46
Above 960	500	54

2. As shown in Section 15.35(b), for frequencies above 1000 MHz, the above field strength limits in paragraphs (a) and (b) of this section are based on average limits. However, the peak field strength of any emission shall not exceed the maximum permitted average limits specified above by more than 20 dB under any condition of modulation. For point-to-point operation under paragraph (b) of this section, the peak field strength shall not exceed 2500 millivolts/meter at 3 meters along the antenna azimuth.

Test Configuration

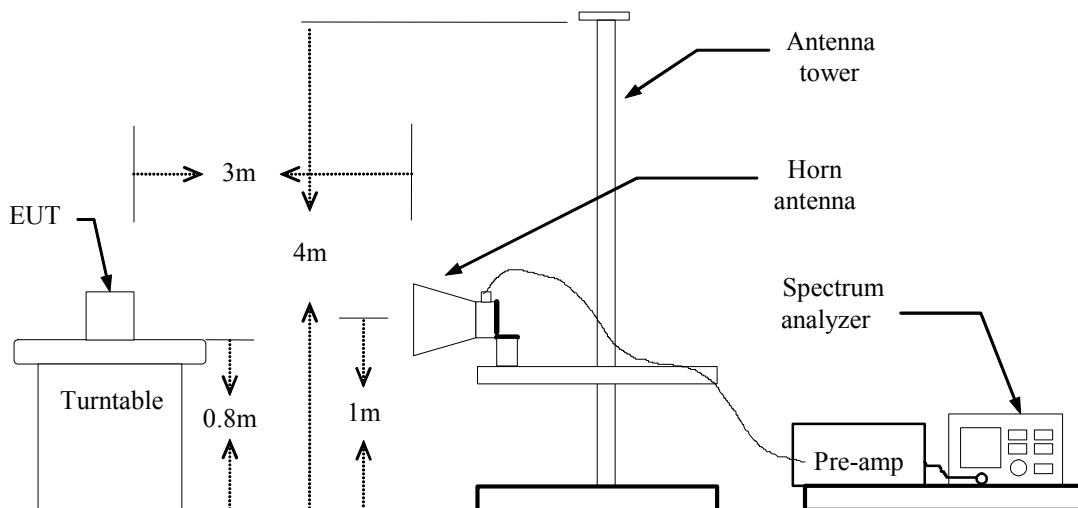

TEST PROCEDURE

1. The EUT is placed on a turntable, which is 0.8m above the ground plane.
2. The turntable shall be rotated for 360 degrees to determine the position of maximum emission level.
3. EUT is set 3m away from the receiving antenna, which is varied from 1m to 4m to find out the highest emission.
4. Set the spectrum analyzer in the following setting in order to capture the lower and upper band-edges of the emission:
 - (a) PEAK: RBW=VBW=1MHz / Sweep=AUTO
 - (b) AVERAGE: RBW=1MHz / VBW=10Hz / Sweep=AUTO
5. Repeat the procedures until all the PEAK and AVERAGE versus POLARIZATION are measured.



TEST RESULTS

Refer to attach spectrum analyzer data chart.

TX Mode Xaxis

Channel	Polarity	Freq.(MHz)	Level(dBuV)	Limit(dBuV)	Margin(dB)	Detector
LOW	H	2390.00	54.56	74	-19.44	Peak
	H	2390.00	42.42	54	-11.58	Average
	V	2390.00	53.72	74	-20.28	Peak
	V	2390.00	42.4	54	-11.60	Average
HIGH	H	2483.50	53.91	74	-20.09	Peak
	H	2483.50	42.2	54	-11.80	Average
	V	2483.50	55.49	74	-18.51	Peak
	V	2483.50	42.22	54	-11.78	Average



Band Edges (CH Low) X axis

Detector mode: Peak

Polarity: Vertical

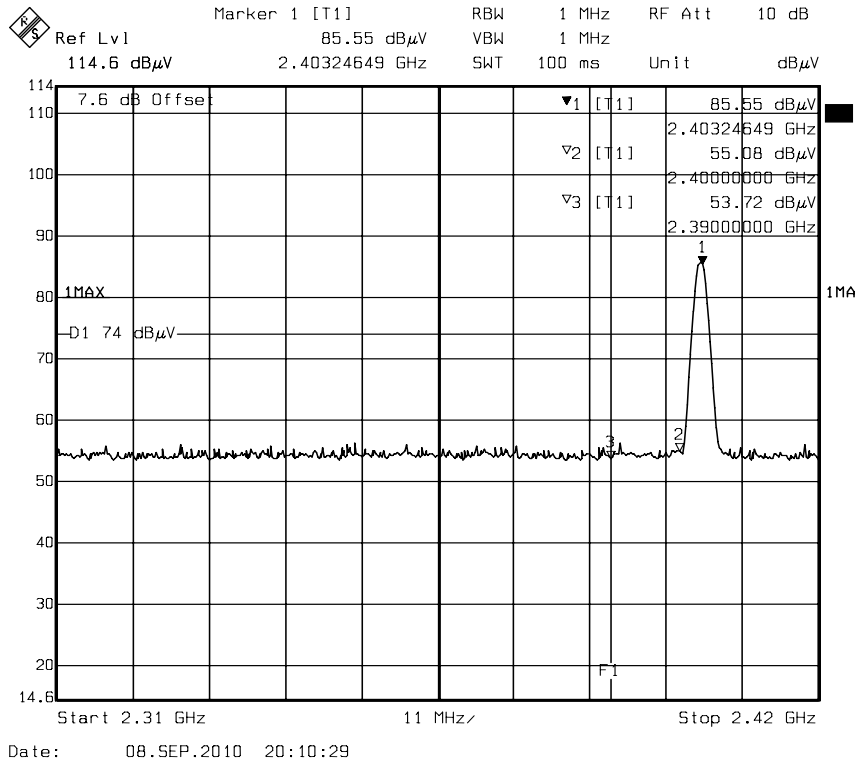

Detector mode: Average

Polarity: Vertical

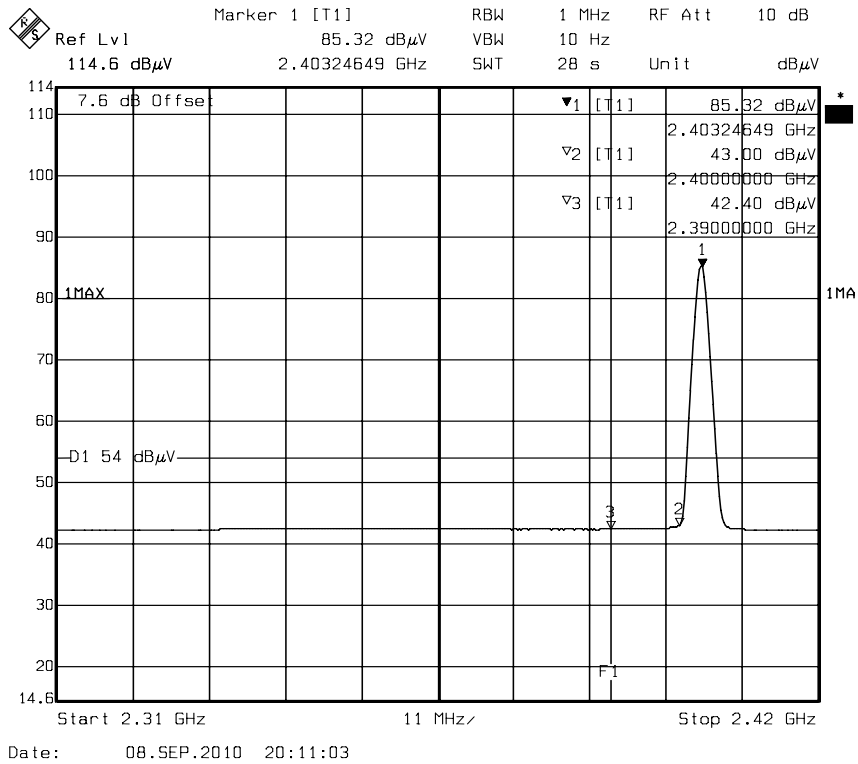



Detector mode: Peak

Polarity: Horizontal

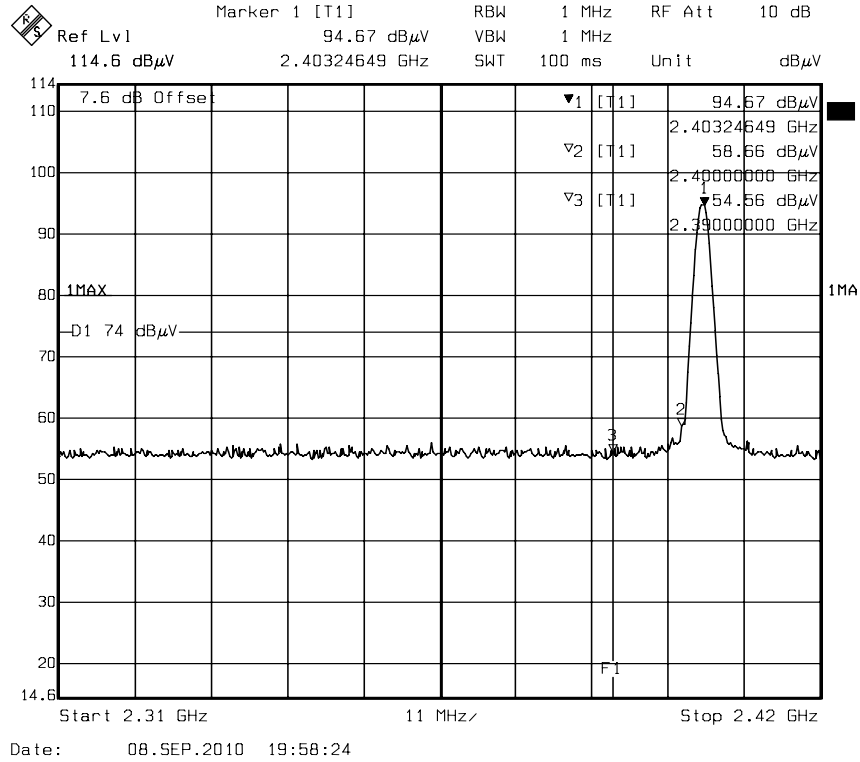

Detector mode: Average

Polarity: Horizontal

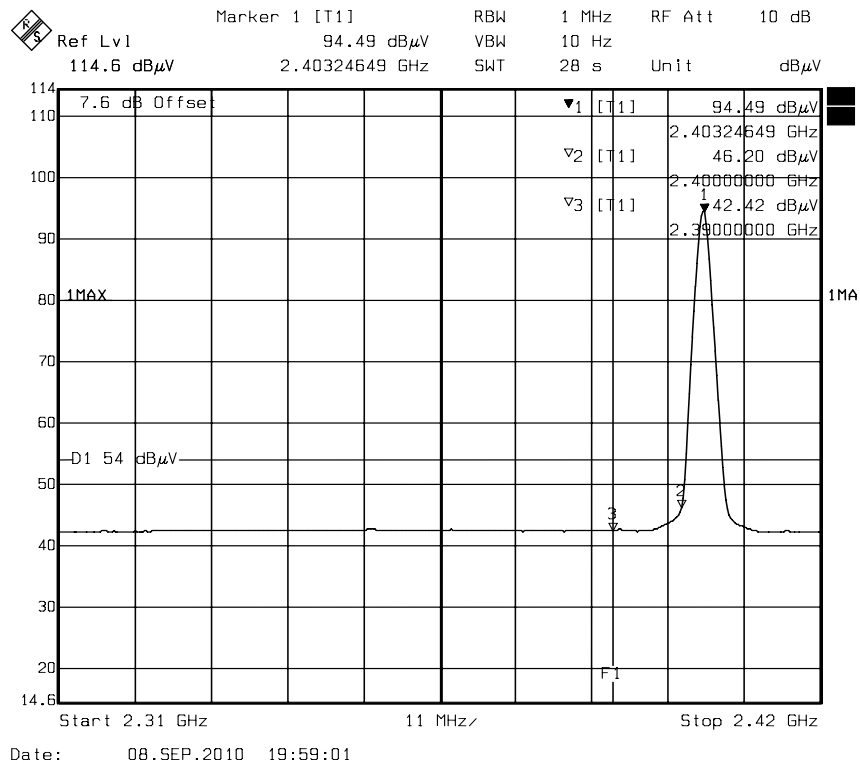



Band Edges (CH High) X axis

Detector mode: Peak

Polarity: Vertical

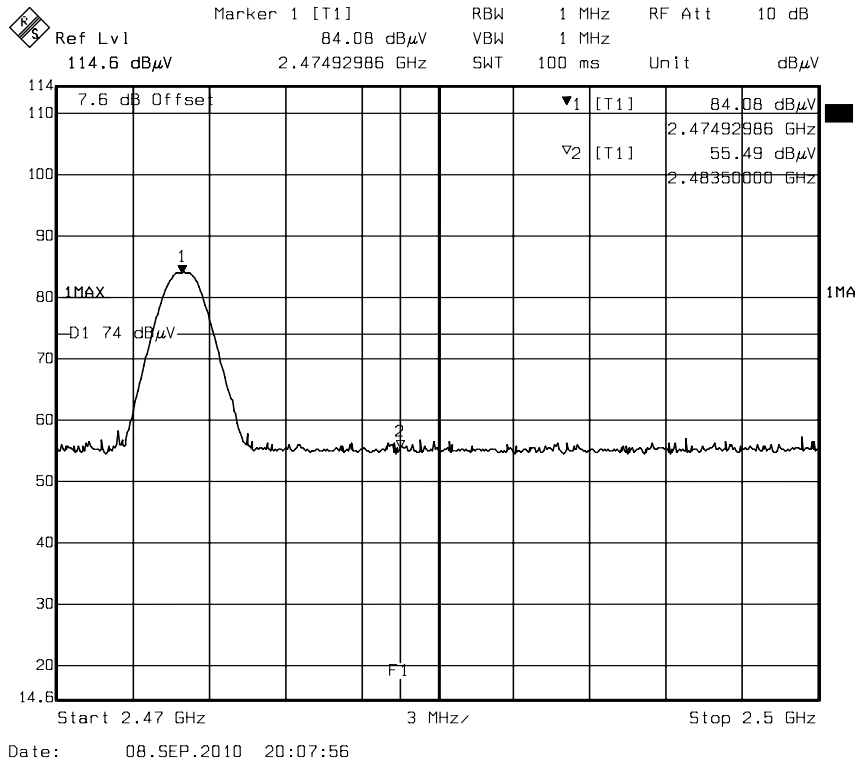

Detector mode: Average

Polarity: Vertical

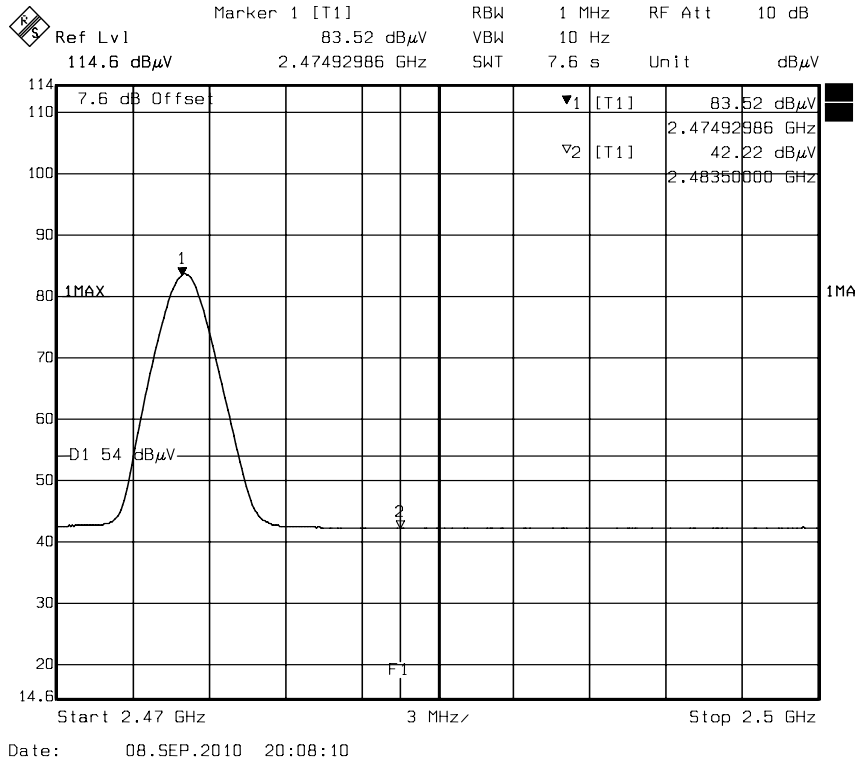

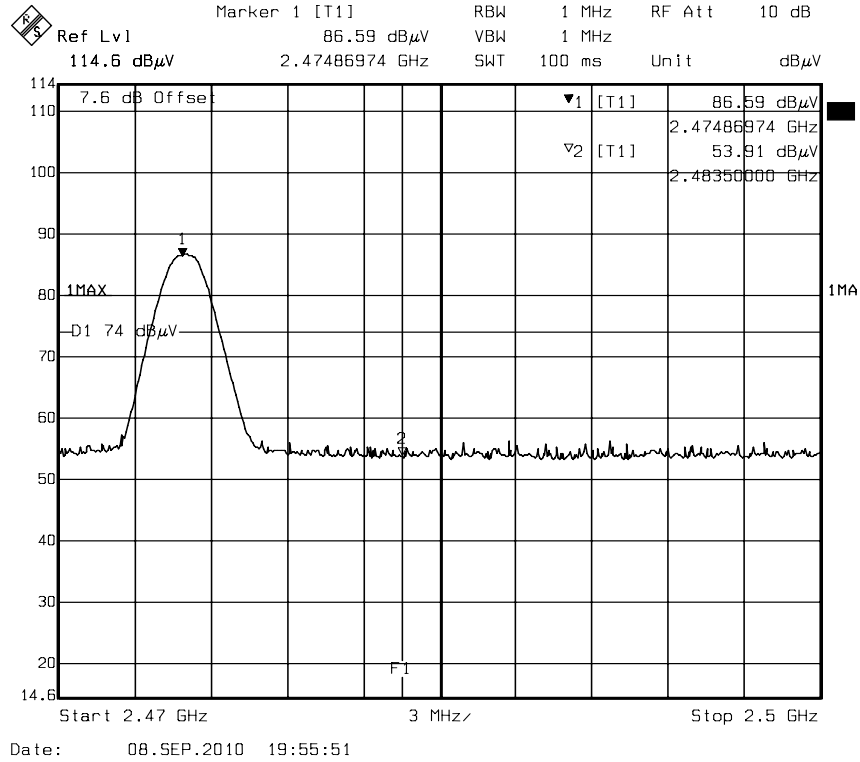
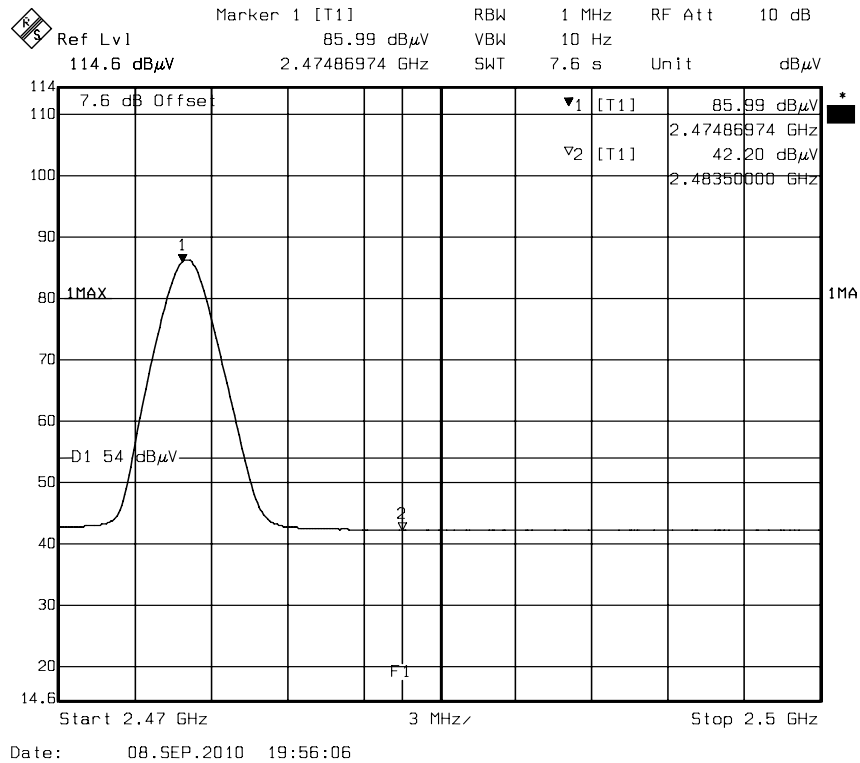
**Detector mode: Peak****Polarity: Horizontal****Detector mode: Average****Polarity: Horizontal**



7.3 SPURIOUS EMISSION

LIMIT

1. In the section 15.249(a):

Except as provided in paragraph (b) of this section, the field strength of emissions from intentional radiators operated within these frequency bands shall comply with the following:

Fundamental Frequency (MHz)	Field Strength of Fundamental Field Strength (mV/m)	Field Strength of Harmonics (µV/m)
902-928 MHz	50	500
2400 - 2483.5 MHz	50	500
5725 - 5875 MHz	50	500
24.0 - 24.25 GHz	250	2500

2. Except as provided elsewhere in this Subpart, the emissions from an intentional radiator shall not exceed the field strength levels specified in the following table:

Frequency (MHz)	Field Strength (µV/m)	Measurement Distance (m)
30-88	100*	3
88-216	150*	3
216-960	200*	3
Above 960	500	3

Remark: Except as provided in paragraph (g), fundamental emissions from intentional radiators operating under this Section shall not be located in the frequency bands 54-72 MHz, 76-88 MHz, 174-216 MHz or 470-806 MHz. However, operation within these frequency bands is permitted under other sections of this Part, e.g., Sections 15.231 and 15.241.

3. In the above emission table, the tighter limit applies at the band edges.

Frequency (MHz)	Field Strength (µV/m at 3-meter)	Field Strength (dBµV/m at 3-meter)
30-88	100	40
88-216	150	43.5
216-960	200	46
Above 960	500	54



Test Configuration

The diagram below shows the test setup that is utilized to make the measurements for emission from below 1GHz.

9kHz ~ 30MHz

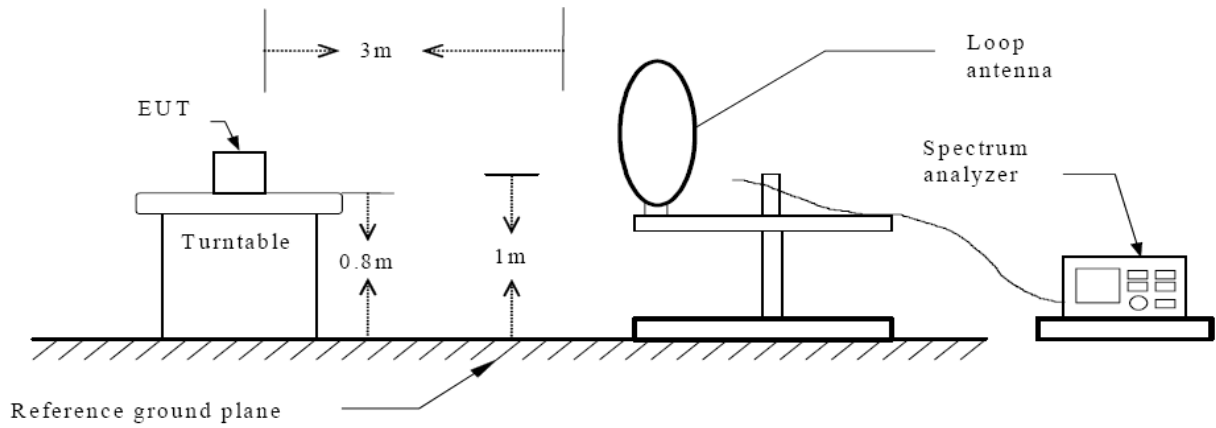

30MHz ~ 1GHz

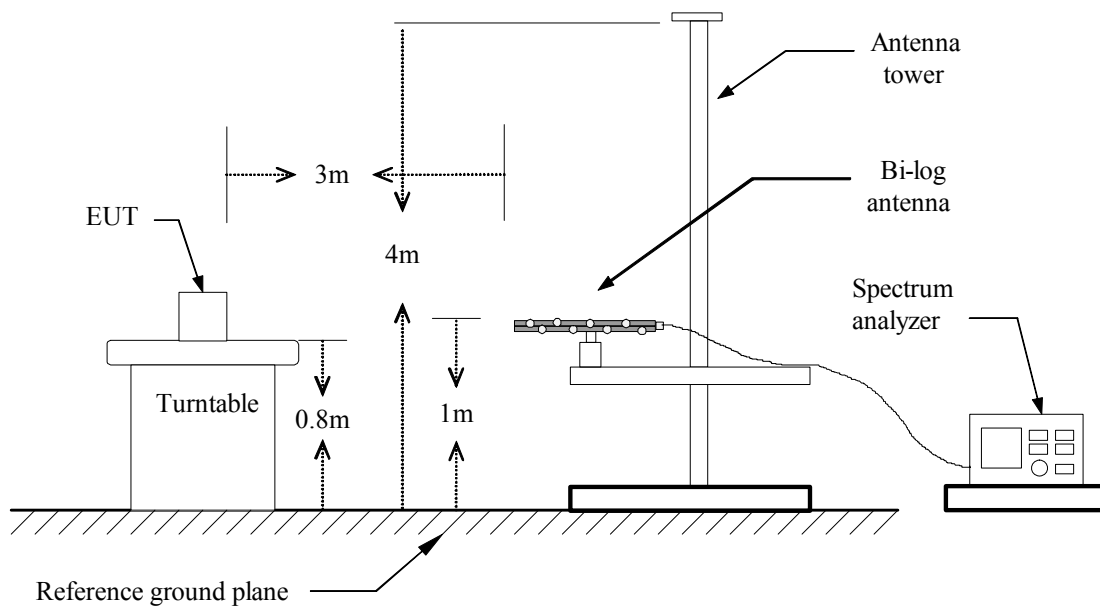



The diagram below shows the test setup that is utilized to make the measurements for emission above 1GHz.

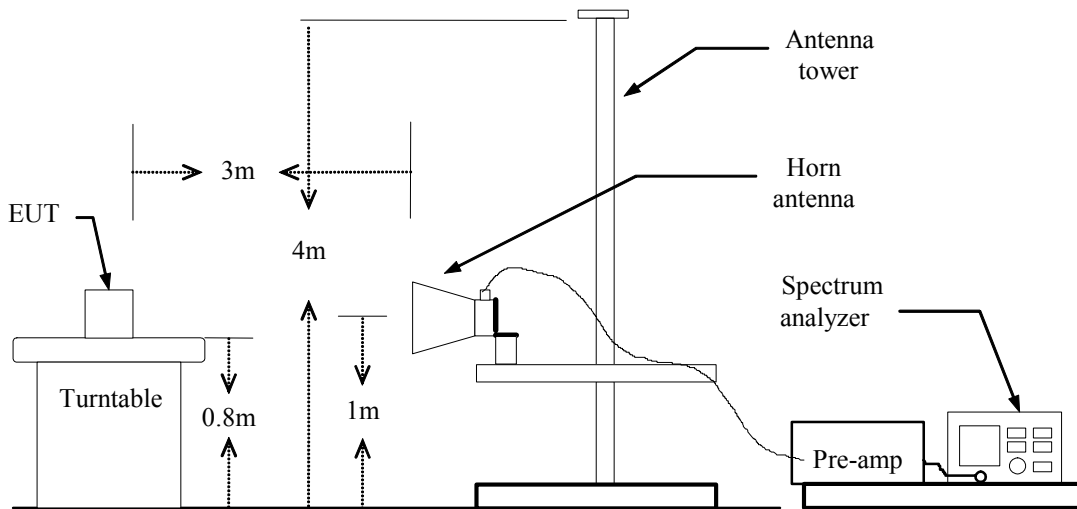

TEST PROCEDURE

- a. The EUT was placed on the top of a rotating table 0.8 meters above the ground at a 10 meter open area test site. The table was rotated 360 degrees to determine the position of the highest radiation.
- b. While measuring the radiated emission below 1GHz, the EUT was set 3 meters away from the interference-receiving antenna, which was mounted on the top of a variable-height antenna tower. While measuring the radiated emission above 1GHz, the EUT was set 3 meters away from the interference-receiving antenna
- c. The antenna is a broadband antenna, and its height is varied from one meter to four meters above the ground to determine the maximum value of the field strength. Both horizontal and vertical polarization of the antenna are set to make the measurement.
- d. For each suspected emission, the EUT was arranged to its worst case and then the antenna was tuned to heights from 1 meter to 4 meters and the table was turned from 0 degrees to 360 degrees to find the maximum reading.
- e. The test-receiver system was set to Peak Detect Function and Specified Bandwidth with Maximum Hold Mode.
- f. If the emission level of the EUT in peak mode was 10 dB lower than the limit specified, then testing could be stopped and the peak values of the EUT would be reported. Otherwise the emissions that did not have 10 dB margin would be re-tested one by one using peak, quasi-peak or average method as specified and then reported in a data sheet.

Note :

1. The resolution bandwidth and video bandwidth of test receiver/spectrum analyzer is 120 KHz for Peak detection (PK) and Quasi-peak detection (QP) at frequency below 1GHz.
2. The resolution bandwidth and video bandwidth of test receiver/spectrum analyzer is 1 MHz for Peak detection and frequency above 1GHz.
3. The resolution bandwidth of test receiver/spectrum analyzer is 1 MHz and the video bandwidth is 10 Hz for Average detection (AV) at frequency above 1GH



Below 1 GHz

Operation Mode: Normal Operation **Test Date:** September 9, 2010
Temperature: 34.9 °C **Tested by:** Eric. Yang
Humidity: 57 % RH **Polarity:** Vertical

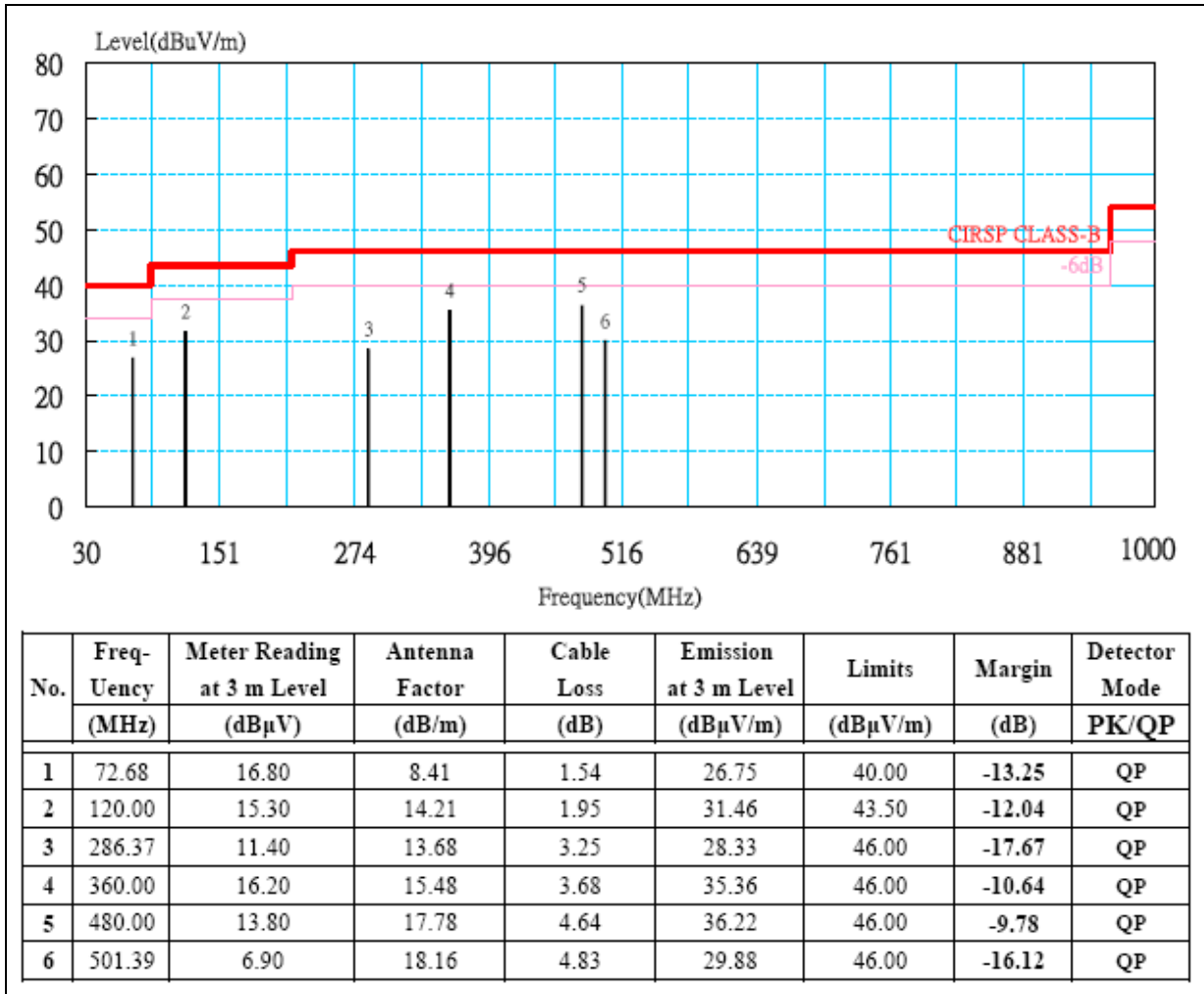

Remark:

1. No emission found between lowest internal used/generated frequency to 30MHz (9kHz~30MHz).
2. Radiated emissions measured were made with an instrument using peak/quasi-peak detector mode.
3. Quasi-peak test would be performed if the peak result were greater than the quasi-peak limit or as required by the applicant.
4. Measurements above show only up to 6 maximum emissions noted, or would be lesser, with " N/A " remark, if no specific emissions from the EUT are recorded (ie: margin>20dB from the applicable limit) and considered that's already beyond the background noise floor.
5. Margin (dB) = Remark result (dBuV/m) – Quasi-peak limit (dBuV/m).



Operation Mode: Normal Operation **Test Date:** September 9, 2010
Temperature: 34.9 °C **Tested by:** Eric. Yang
Humidity: 57 % RH **Polarity:** Horizontal

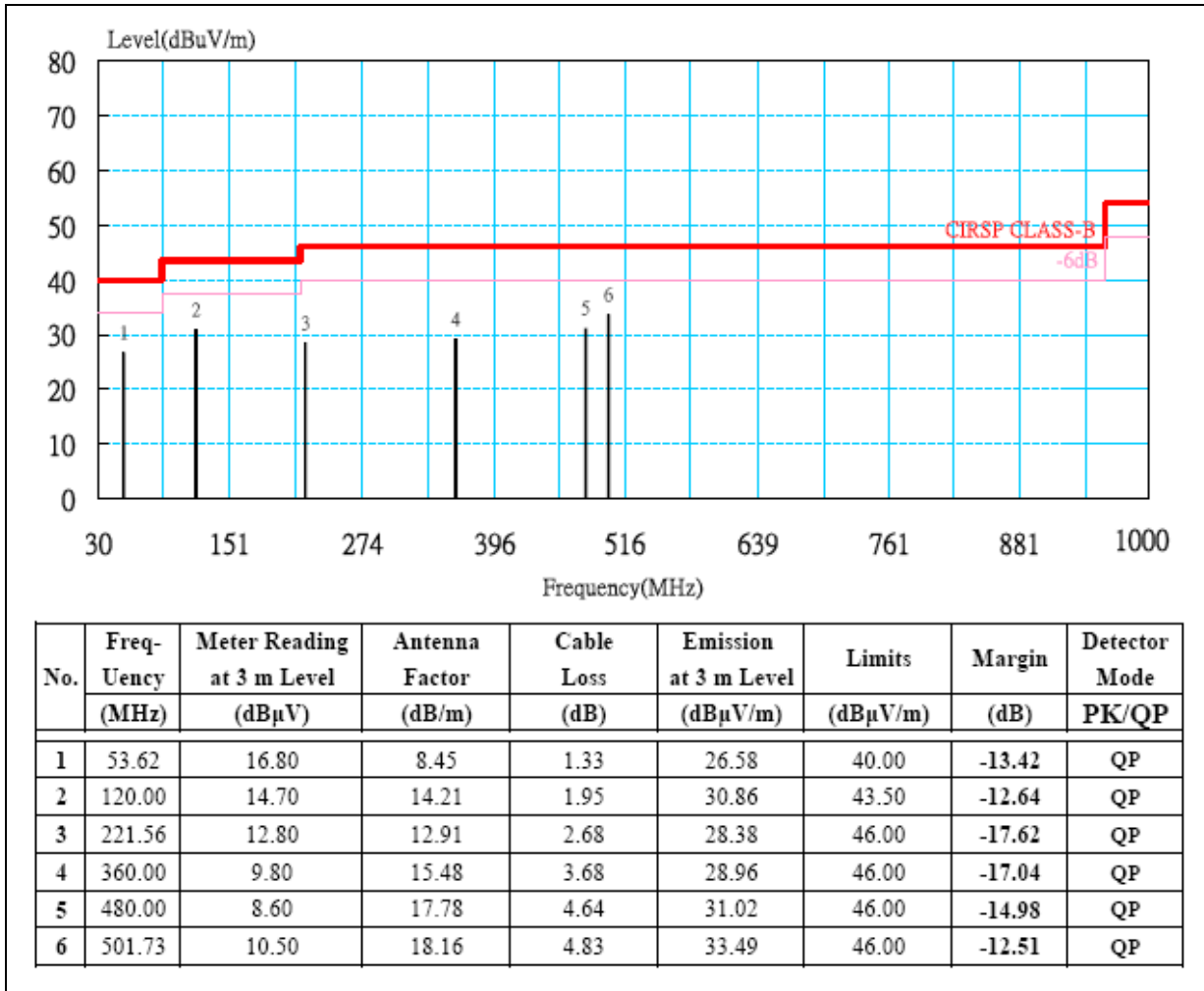

No.	Freq- uency (MHz)	Meter Reading at 3 m Level (dBμV)	Antenna Factor (dB/m)	Cable Loss (dB)	Emission at 3 m Level (dBμV/m)	Limits (dBμV/m)	Margin (dB)	Detector Mode PK/QP
1	53.62	16.80	8.45	1.33	26.58	40.00	-13.42	QP
2	120.00	14.70	14.21	1.95	30.86	43.50	-12.64	QP
3	221.56	12.80	12.91	2.68	28.38	46.00	-17.62	QP
4	360.00	9.80	15.48	3.68	28.96	46.00	-17.04	QP
5	480.00	8.60	17.78	4.64	31.02	46.00	-14.98	QP
6	501.73	10.50	18.16	4.83	33.49	46.00	-12.51	QP

Remark:

1. No emission found between lowest internal used/generated frequency to 30MHz (9kHz~30MHz).
2. Radiated emissions measured were made with an instrument using peak/quasi-peak detector mode.
3. Quasi-peak test would be performed if the peak result were greater than the quasi-peak limit or as required by the applicant.
4. Measurements above show only up to 6 maximum emissions noted, or would be lesser, with “ N/A ” remark, if no specific emissions from the EUT are recorded (ie: margin>20dB from the applicable limit) and considered that's already beyond the background noise floor.
5. Margin (dB) = Remark result (dBuV/m) – Quasi-peak limit (dBuV/m).

**Above 1 GHz**

Product Name	Air Dongle	Test Date	September 8, 2010
Model	UD08b	Test By	Eric Yang
Test Mode	TX (CH Low) X axis	Temp& Humidity	27.5°C, 51%

Horizontal

TX mode / CH Low				Measurement Distance at 3m				Horizontal polarity	
Freq.	Reading	AF	Cable Loss	Pre-amp	Filter	Level	Limit	Margin	Mark
(MHz)	(dBμV)	(dB/m)	(dB)	(dB)	(dB)	(dBμV/m)	(dBμV/m)	(dB)	(P/Q/A)
2403.16	102.65	29.84	2.62	41.10	0.00	94.00	114.00	-20.00	P
2403.16	101.13	29.84	2.62	41.10	0.00	92.48	94.00	-1.52	A
* 4803.23	60.44	33.11	3.72	42.36	0.69	55.60	74.00	-18.40	P
* 4803.23	57.11	33.11	3.72	42.36	0.69	52.27	54.00	-1.73	A
7203.99	51.85	38.51	4.66	41.89	1.37	54.49	74.00	-19.51	P
7203.99	43.56	38.51	4.66	41.89	1.37	46.20	72.48	-26.28	A
N/A	-----	-----	-----	-----	-----	-----	-----	-----	P
N/A	-----	-----	-----	-----	-----	-----	-----	-----	A

Remark:

1. AF: Antenna Factor, Cable: Cable Loss, Pre-Amp: Preamplifier gain, Filter: High Pass Filter Insertion Loss (3.5GHz)
2. Spectrum analyzer setting P(Peak): RBW=1MHz, VBW=1MHz, A(Average): RBW=1MHz, VBW=10Hz
3. The result basic equation calculation is as follow:
Level = Reading + AF + Cable – Preamp + Filter, Margin = Level-Limit
4. The other emission levels were 20dB below the limit
5. The test limit distance is 3M limit.



Product Name	Air Dongle	Test Date	September 8, 2010
Model	UD08b	Test By	Eric Yang
Test Mode	TX (CH Low) X axis	Temp& Humidity	27.5°C, 51%

Vertical

TX mode / CH Low				Measurement Distance at 3m				Vertical polarity	
Freq.	Reading	AF	Cable Loss	Pre-amp	Filter	Level	Limit	Margin	Mark
(MHz)	(dBμV)	(dB/m)	(dB)	(dB)	(dB)	(dBμV/m)	(dBμV/m)	(dB)	(P/Q/A)
2403.21	100.68	29.84	2.62	41.10	0.00	92.03	114.00	-21.97	P
2403.21	99.25	29.84	2.62	41.10	0.00	90.60	94.00	-3.40	A
* 4802.99	58.57	33.11	3.72	42.36	0.69	53.73	74.00	-20.27	P
* 4802.99	54.90	33.11	3.72	42.36	0.69	50.06	54.00	-3.94	A
7204.05	53.21	38.51	4.66	41.89	1.37	55.86	74.00	-18.14	P
7204.05	46.01	38.51	4.66	41.89	1.37	48.66	70.60	-21.95	A
N/A	-----	-----	-----	-----	-----	-----	-----	-----	P
N/A	-----	-----	-----	-----	-----	-----	-----	-----	A

Remark:

1. AF: Antenna Factor, Cable: Cable Loss, Pre-Amp: Preamplifier gain, Filter: High Pass Filter Insertion Loss (3.5GHz)
2. Spectrum analyzer setting P(Peak): RBW=1MHz, VBW=1MHz, A(Average): RBW=1MHz, VBW=10Hz
3. The result basic equation calculation is as follow:
Level = Reading + AF + Cable – Preamp + Filter, Margin = Level-Limit
4. The other emission levels were 20dB below the limit
5. The test limit distance is 3M limit.



Product Name	Air Dongle	Test Date	September 8, 2010
Model	UD08b	Test By	Eric Yang
Test Mode	TX (CH Mid) X axis	Temp& Humidity	27.5°C, 51%

Horizontal

TX mode / CH Mid				Measurement Distance at 3m			Horizontal polarity		
Freq.	Reading	AF	Cable Loss	Pre-amp	Filter	Level	Limit	Margin	Mark
(MHz)	(dBμV)	(dB/m)	(dB)	(dB)	(dB)	(dBμV/m)	(dBμV/m)	(dB)	(P/Q/A)
2439.05	101.65	29.79	2.63	41.10	0.00	92.96	114.00	-21.04	P
2439.05	101.15	29.79	2.63	41.10	0.00	92.46	94.00	-1.54	A
* 4805.81	58.84	33.12	3.73	42.37	0.69	54.00	74.00	-20.00	P
* 4805.81	56.32	33.12	3.73	42.37	0.69	51.48	54.00	-2.52	A
7208.60	52.97	38.53	4.66	41.88	1.38	55.65	74.00	-18.35	P
7208.60	46.91	38.53	4.66	41.88	1.38	49.59	72.46	-22.88	A
N/A	-----	-----	-----	-----	-----	-----	-----	-----	P
N/A	-----	-----	-----	-----	-----	-----	-----	-----	A

Remark:

1. AF: Antenna Factor, Cable: Cable Loss, Pre-Amp: Preamplifier gain, Filter: High Pass Filter Insertion Loss (3.5GHz)
2. Spectrum analyzer setting P(Peak): RBW=1MHz, VBW=1MHz, A(Average): RBW=1MHz, VBW=10Hz
3. The result basic equation calculation is as follow:
Level = Reading + AF + Cable – Preamp + Filter, Margin = Level-Limit
4. The other emission levels were 20dB below the limit
5. The test limit distance is 3M limit.



Product Name	Air Dongle	Test Date	September 8, 2010
Model	UD08b	Test By	Eric Yang
Test Mode	TX (CH Mid) X axis	Temp& Humidity	27.5°C, 51%

Vertical

TX mode / CH Mid				Measurement Distance at 3m				Vertical polarity	
Freq.	Reading	AF	Cable Loss	Pre-amp	Filter	Level	Limit	Margin	Mark
(MHz)	(dBμV)	(dB/m)	(dB)	(dB)	(dB)	(dBμV/m)	(dBμV/m)	(dB)	(P/Q/A)
2439.98	100.25	29.78	2.63	41.10	0.00	91.56	114.00	-22.44	P
2439.98	99.54	29.78	2.63	41.10	0.00	90.85	94.00	-3.15	A
* 4806.03	60.14	33.12	3.73	42.37	0.69	55.30	74.00	-18.70	P
* 4806.03	57.72	33.12	3.73	42.37	0.69	52.88	54.00	-1.12	A
7208.77	53.09	38.53	4.66	41.88	1.38	55.77	74.00	-18.23	P
7208.77	46.78	38.53	4.66	41.88	1.38	49.46	70.85	-21.39	A
N/A	-----	-----	-----	-----	-----	-----	-----	-----	P
N/A	-----	-----	-----	-----	-----	-----	-----	-----	A

Remark:

1. AF: Antenna Factor, Cable: Cable Loss, Pre-Amp: Preamplifier gain, Filter: High Pass Filter Insertion Loss (3.5GHz)
2. Spectrum analyzer setting P(Peak): RBW=1MHz, VBW=1MHz, A(Average): RBW=1MHz, VBW=10Hz
3. The result basic equation calculation is as follow:
Level = Reading + AF + Cable – Preamp + Filter, Margin = Level-Limit
4. The other emission levels were 20dB below the limit
5. The test limit distance is 3M limit.



Product Name	Air Dongle	Test Date	September 8, 2010
Model	UD08b	Test By	Eric Yang
Test Mode	TX (CH High) X axis	Temp& Humidity	27.5°C, 51%

Horizontal

	TX mode / CH High				Measurement Distance at 3m				Horizontal polarity	
	Freq. (MHz)	Reading (dBμV)	AF (dB/m)	Cable Loss (dB)	Pre-amp (dB)	Filter (dB)	Level (dBμV/m)	Limit (dBμV/m)	Margin (dB)	Mark (P/Q/A)
	2475.03	101.36	29.73	2.65	41.11	0.00	92.64	114.00	-21.36	P
	2475.03	100.83	29.73	2.65	41.11	0.00	92.11	94.00	-1.89	A
*	4950.03	59.65	33.55	3.77	42.51	0.74	55.20	74.00	-18.80	P
*	4950.03	55.65	33.55	3.77	42.51	0.74	51.20	54.00	-2.80	A
*	7425.03	52.65	39.18	4.76	41.55	1.84	56.88	74.00	-17.12	P
*	7425.03	46.33	39.18	4.76	41.55	1.84	50.56	54.00	-3.44	A
	N/A	-----	-----	-----	-----	-----	-----	-----	-----	P
	N/A	-----	-----	-----	-----	-----	-----	-----	-----	A

Remark:

1. AF: Antenna Factor, Cable: Cable Loss, Pre-Amp: Preamplifier gain, Filter: High Pass Filter Insertion Loss (3.5GHz)
2. Spectrum analyzer setting P(Peak): RBW=1MHz, VBW=1MHz, A(Average): RBW=1MHz, VBW=10Hz
3. The result basic equation calculation is as follow:
Level = Reading + AF + Cable – Preamp + Filter, Margin = Level-Limit
4. The other emission levels were 20dB below the limit
5. The test limit distance is 3M limit.



Product Name	Air Dongle	Test Date	September 8, 2010
Model	UD08b	Test By	Eric Yang
Test Mode	TX (CH High) X axis	Temp& Humidity	27.5°C, 51%

Vertical

TX mode / CH High				Measurement Distance at 3m				Vertical polarity	
Freq.	Reading	AF	Cable Loss	Pre-amp	Filter	Level	Limit	Margin	Mark
(MHz)	(dBμV)	(dB/m)	(dB)	(dB)	(dB)	(dBμV/m)	(dBμV/m)	(dB)	(P/Q/A)
2474.96	99.98	29.74	2.65	41.11	0.00	91.26	114.00	-22.74	P
2474.96	99.43	29.74	2.65	41.11	0.00	90.71	94.00	-3.29	A
* 4949.98	59.87	33.55	3.77	42.51	0.74	55.42	74.00	-18.58	P
* 4949.98	57.16	33.55	3.77	42.51	0.74	52.71	54.00	-1.29	A
* 7425.06	53.14	39.18	4.76	41.55	1.84	57.37	74.00	-16.63	P
* 7425.06	46.25	39.18	4.76	41.55	1.84	50.48	54.00	-3.52	A
N/A	-----	-----	-----	-----	-----	-----	-----	-----	P
N/A	-----	-----	-----	-----	-----	-----	-----	-----	A

Remark:

1. AF: Antenna Factor, Cable: Cable Loss, Pre-Amp: Preamplifier gain, Filter: High Pass Filter Insertion Loss (3.5GHz)
2. Spectrum analyzer setting P(Peak): RBW=1MHz, VBW=1MHz, A(Average): RBW=1MHz, VBW=10Hz
3. The result basic equation calculation is as follow:
Level = Reading + AF + Cable – Preamp + Filter, Margin = Level-Limit
4. The other emission levels were 20dB below the limit
5. The test limit distance is 3M limit.



7.4 POWERLINE CONDUCTED EMISSIONS

LIMIT

According to §15.207(a), except as shown in paragraphs (b) and (c) of this section, for an intentional radiator that is designed to be connected to the public utility (AC) power line, the radio frequency voltage that is conducted back onto the AC power line on any frequency or frequencies within the band 150 kHz to 30 MHz shall not exceed the limits in the following table, as measured using a 50 μ H/50 ohms line impedance stabilization network (LISN). Compliance with the provisions of this paragraph shall be based on the measurement of the radio frequency voltage between each power line and ground at the power terminal. The lower limit applies at the boundary between the frequency ranges.

Frequency Range (MHz)	Limits (dB μ V)	
	Quasi-peak	Average
0.15 to 0.50	66 to 56*	56 to 46*
0.50 to 5	56	46
5 to 30	60	50

* Decreases with the logarithm of the frequency.

Test Configuration

See test photographs attached in Appendix I for the actual connections between EUT and support equipment.

TEST PROCEDURE

1. The EUT was placed on a table, which is 0.8m above ground plane.
2. Maximum procedure was performed on the six highest emissions to ensure EUT compliance.
3. Repeat above procedures until all frequency measured were complete.



TEST RESULTS

Operation Mode: TX + RX mode Test Date: September 9, 2010
Temperature: 24.4°C Humidity: 59 RH
Tested by: Hong Tsai Test Mode: Normal Link

Conducted emissions (Line)

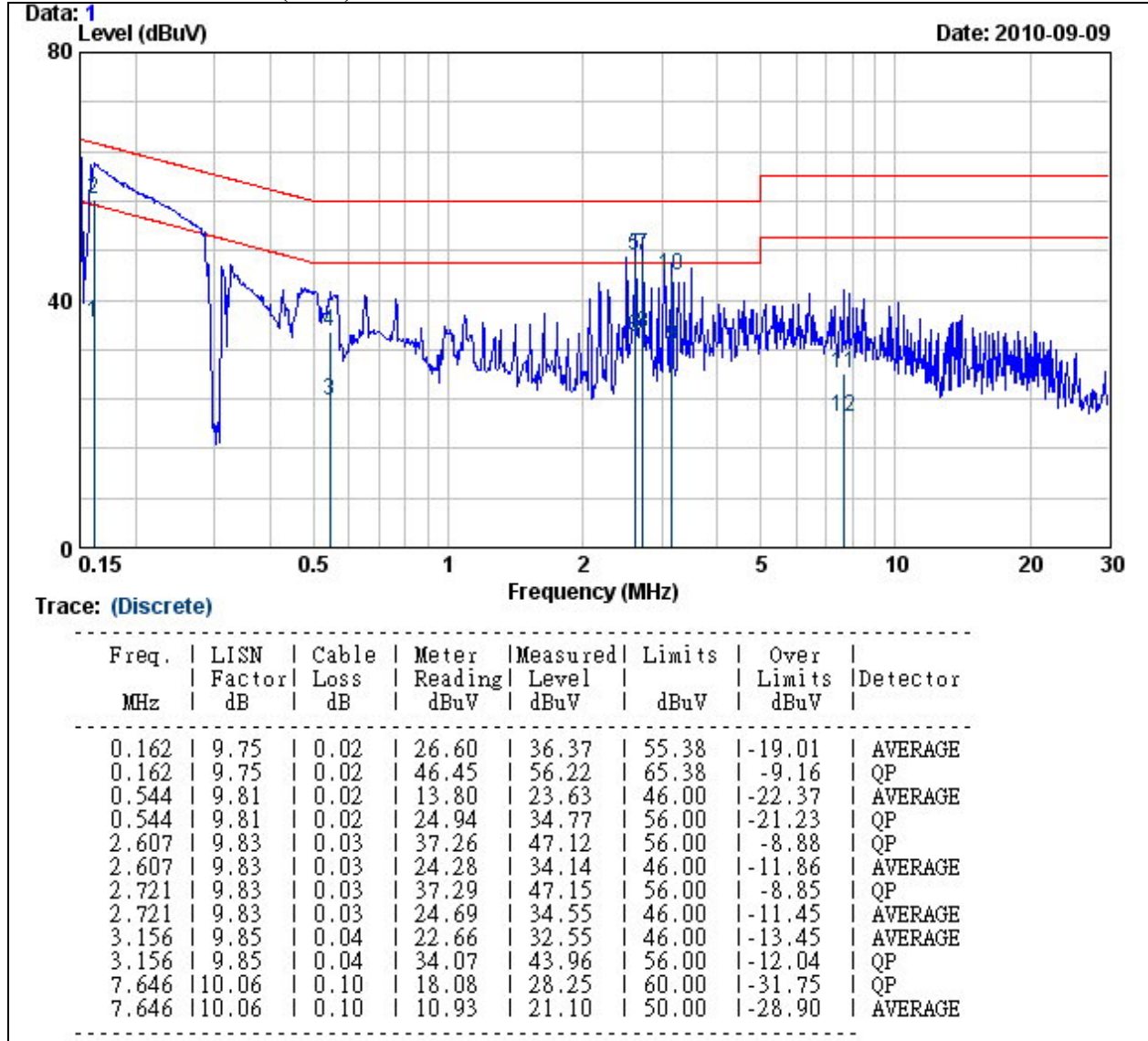

Remark:

- 1 Measuring frequencies from 0.15 MHz to 30MHz.
2 The emissions measured in frequency range from 0.15 MHz to 30MHz were made with an instrument using Quasi-peak detector and average detector.
3 The IF bandwidth of SPA between 0.15MHz to 30MHz was 10kHz; the IF bandwidth of Test Receiver between 0.15MHz to 30MHz was 9kHz;
4 a. Level (dBuV) = Read Level (dBuV) + LISN Factor (dB) + Cable Loss (dB)
b.Over Limit value (dB) = Level (dBuV) – Limit Line (dBuV)



Operation Mode: TX + RX mode

Test Date: September 9, 2010

Temperature: 24.4°C

Humidity: 59 RH

Tested by: Hone Tsai

Test Mode: Normal Link

Conducted emissions (Neutral)

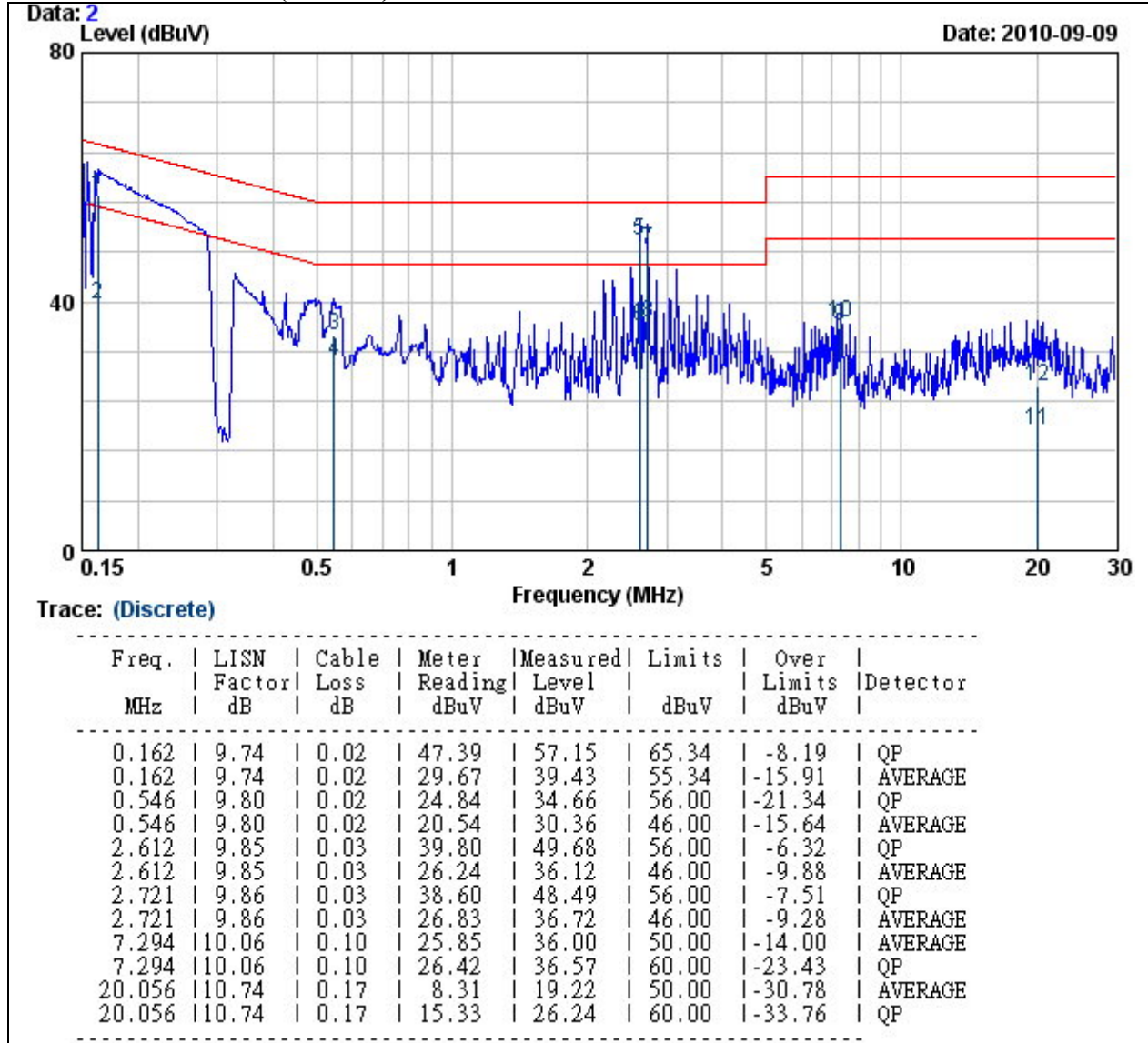

Remark:

- 1 Measuring frequencies from 0.15 MHz to 30MHz.
- 2 The emissions measured in frequency range from 0.15 MHz to 30MHz were made with an instrument using Quasi-peak detector and average detector.
- 3 The IF bandwidth of SPA between 0.15MHz to 30MHz was 10kHz; the IF bandwidth of Test Receiver between 0.15MHz to 30MHz was 9kHz;
- 4 a. Level (dBUV) = Read Level (dBUV) + LISN Factor (dB) + Cable Loss (dB)
b. Over Limit value (dB) = Level (dBUV) – Limit Line (dBUV)