

ANTENNA PRODUCTS

DATA SHEET

**8010 Ceramic Chip Antenna
for Bluetooth/Wimax Application**

Sept., 2008 – V8

R&D	Print date 10/10/07						
	8010 Ceramic Chip Antenna for Bluetooth/Wimax Application			CAN4311 881 XX 245 3K			June, 2008 v6
							Aug, 2008 v7
							Sept, 2008 v8
Justin Liu Oscar Lu	Tommy Chen		Page 1	sheet 190-1			A4
Yageo Taiwan / High Frequency BU							

8010 Ceramic Chip Antenna for Bluetooth/Wimax Application

Quick Reference Data

Centre Frequency	2.38 GHz
Bandwidth	2.3 ~ 2.49 GHz
VSWR	2.5 (Max.)
Polarization	Linear
Azimuth Beamwidth	Omni-directional
Peak Gain	3.0 dBi
Impedance	50Ω
Operating Temperature	-25~85 °C
Termination	Ni / Sn (Environmentally-Friendly Leadless)
Resistance to soldering heats	260°C , 10sec.
Maximum Power	1W

R&D	Print date 10/10/07						
	8010 Ceramic Chip Antenna for Bluetooth/Wimax Application			CAN4311 881 XX 245 3K			June, 2008 v6
							Aug, 2008 v7
							Sept, 2008 v8
Justin Liu Oscar Lu	Tommy Chen			Page 2	sheet 190-2		A4
Yageo Taiwan / High Frequency BU							

1. Mechanical Data (8 x 1x 1 mm³)

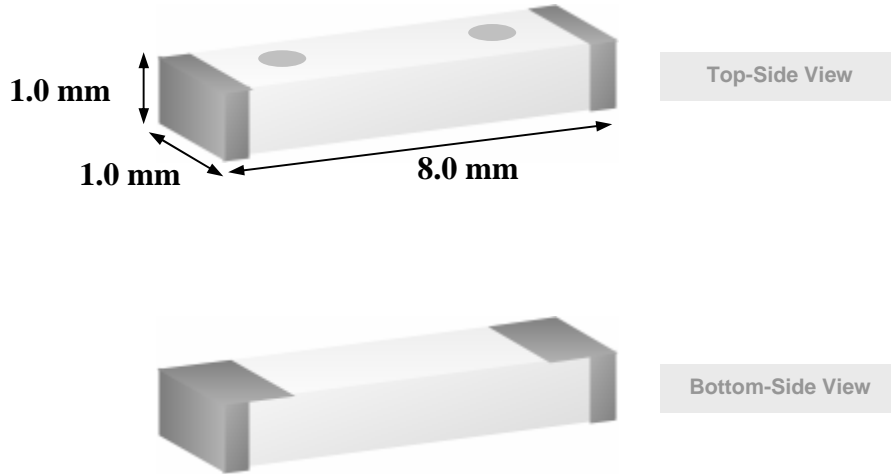

CAN4311881XX2453K

R&D	Print date 10/10/07						
	8010 Ceramic Chip Antenna for Bluetooth/Wimax Application			CAN4311 881 XX 245 3K		June, 2008 v6	
						Aug, 2008 v7	
						Sept, 2008 v8	
Justin Liu Oscar Lu	Tommy Chen		Page 3	sheet 190-3		A4	
Yageo Taiwan / High Frequency BU							

2. Dimension of Footprint

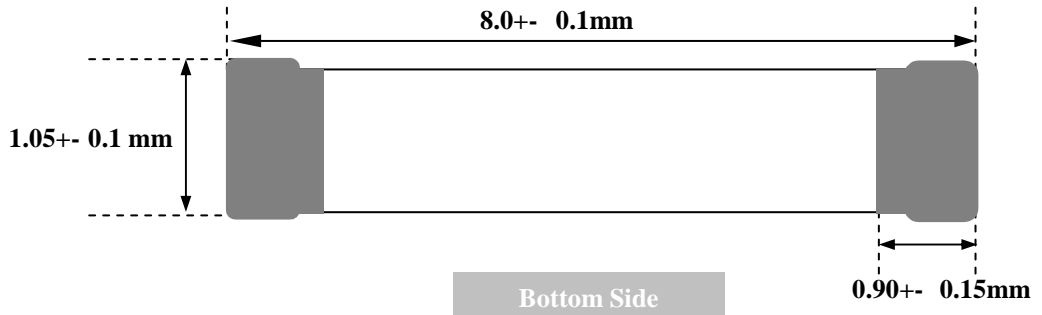
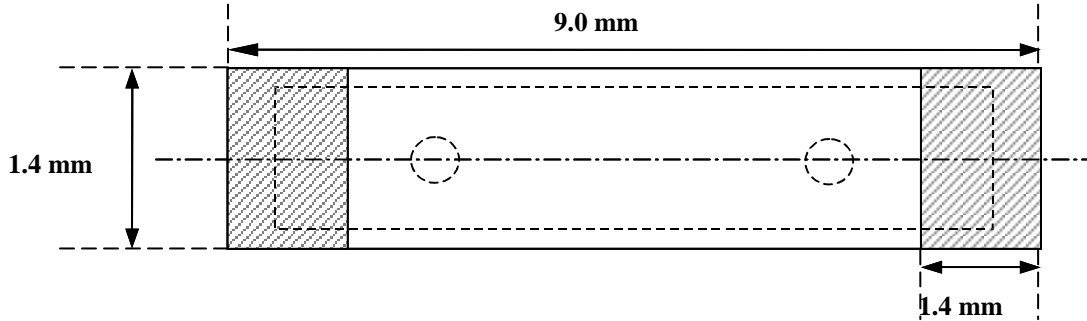

R&D	Print date 10/10/07					
	8010 Ceramic Chip Antenna for Bluetooth/Wimax Application			CAN4311 881 XX 245 3K		June, 2008 v6
						Aug, 2008 v7
						Sept, 2008 v8
Justin Liu Oscar Lu	Tommy Chen		Page 4	sheet 190-4		A4
Yageo Taiwan / High Frequency BU						

3. Evaluation Board Dimension and Outlook

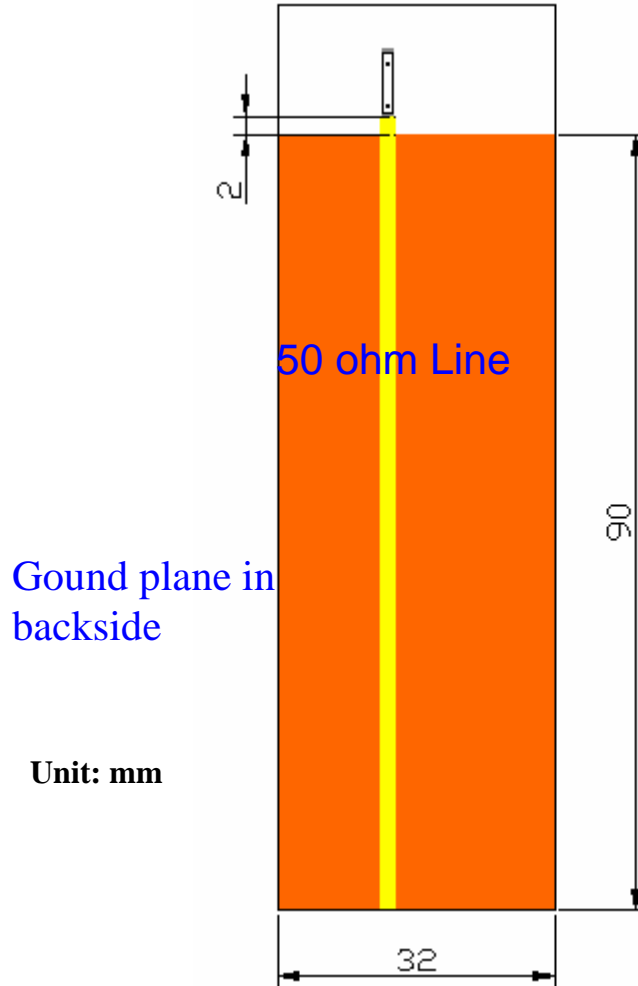

R&D	Print date 10/10/07					
	8010 Ceramic Chip Antenna for Bluetooth/Wimax Application			CAN4311 881 XX 245 3K		June, 2008 v6
						Aug, 2008 v7
						Sept, 2008 v8
Justin Liu Oscar Lu	Tommy Chen		Page 5	sheet 190-5		A4
Yageo Taiwan / High Frequency BU						

4. Measured S-parameter

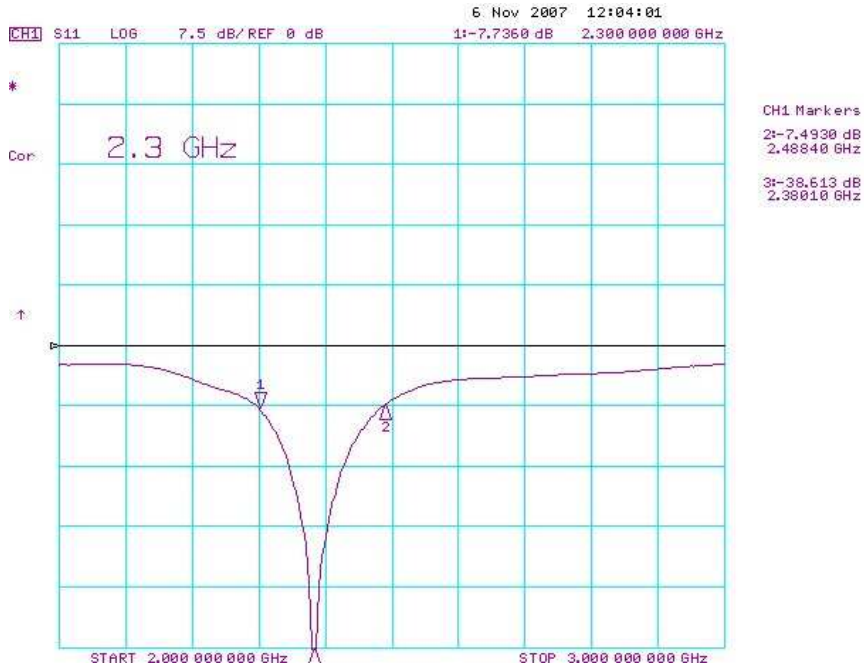

R&D	Print date 10/10/07					June, 2008 v6
	8010 Ceramic Chip Antenna for Bluetooth/Wimax Application		CAN4311 881 XX 245 3K		Aug, 2008 v7	
					Sept, 2008 v8	
Justin Liu	Tommy Chen		Page 6	sheet 190-6		A4
Oscar Lu	Yageo Taiwan / High Frequency BU					

5.The Definition of X-Y-Z Plane

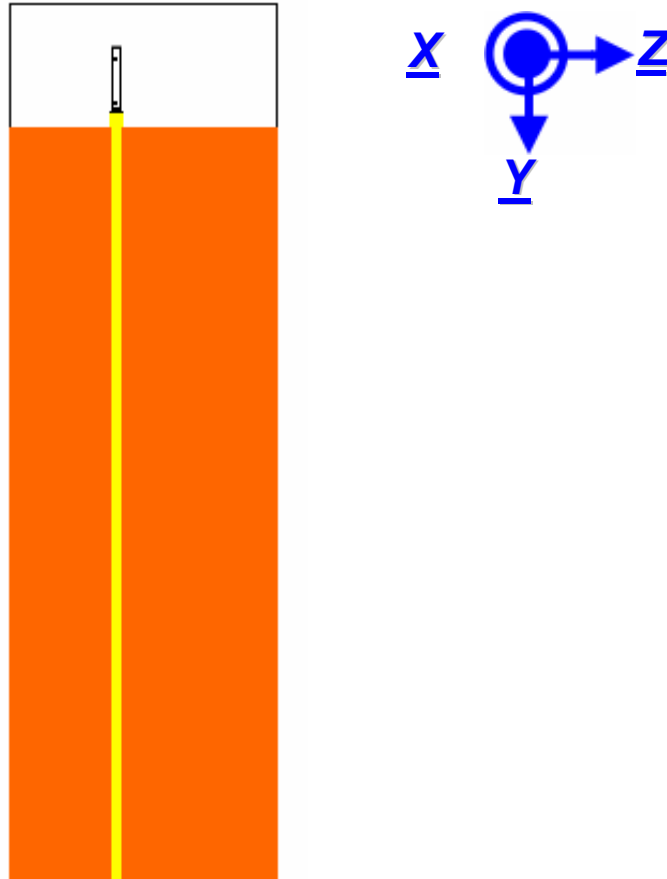

R&D	Print date 10/10/07					
	8010 Ceramic Chip Antenna for Bluetooth/Wimax Application			CAN4311 881 XX 245 3K		June, 2008 v6
						Aug, 2008 v7
						Sept, 2008 v8
Justin Liu Oscar Lu	Tommy Chen		Page 7	sheet 190-7		A4
Yageo Taiwan / High Frequency BU						

6. The Environment of Antenna Radiation Pattern
Anechoic Chamber Dimension=10(m) × 6(m) × 6(m)

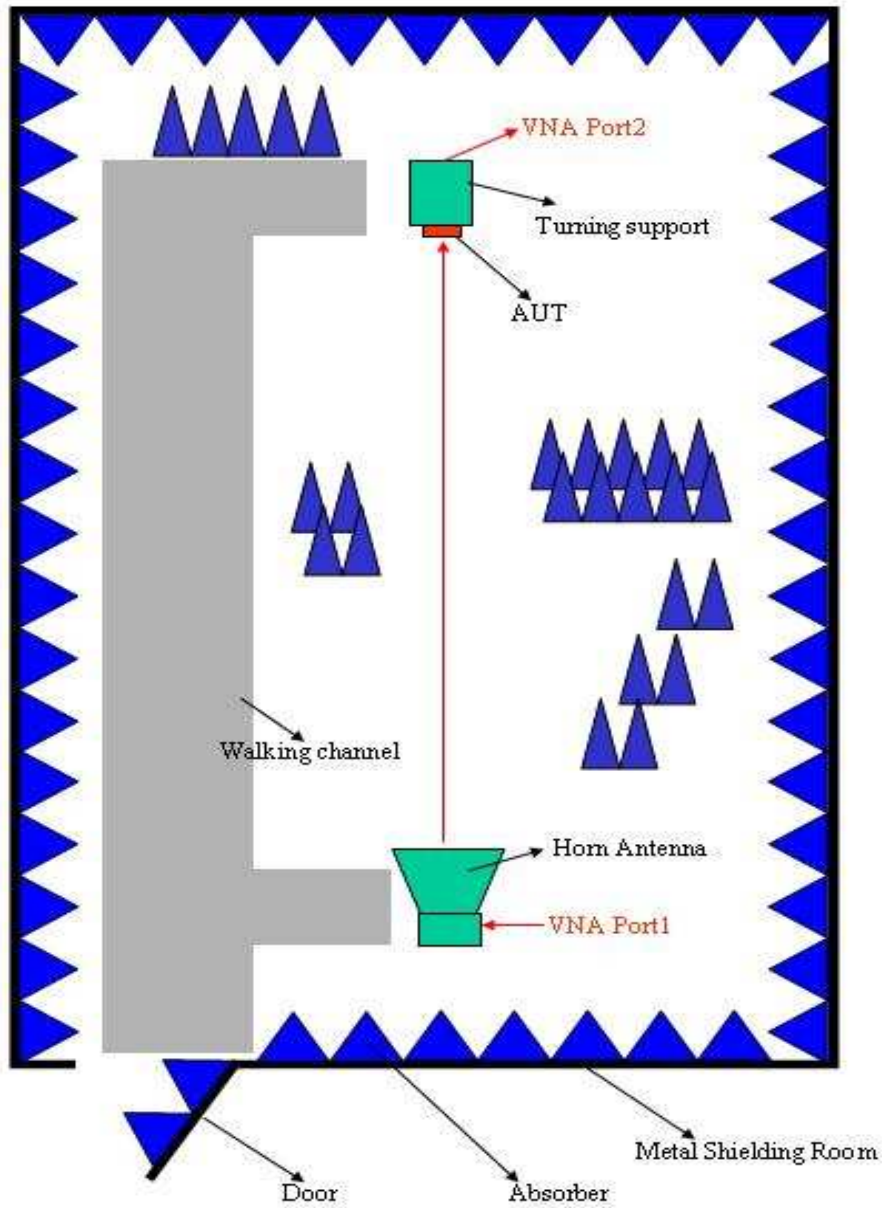

R&D	Print date 10/10/07				
	8010 Ceramic Chip Antenna for Bluetooth/Wimax Application	CAN4311 881 XX 245 3K	June, 2008 v6		
			Aug, 2008 v7		
			Sept, 2008 v8		
Justin Liu Oscar Lu	Tommy Chen		Page 8	sheet 190-8	A4
Yageo Taiwan / High Frequency BU					

7. Radiation Pattern

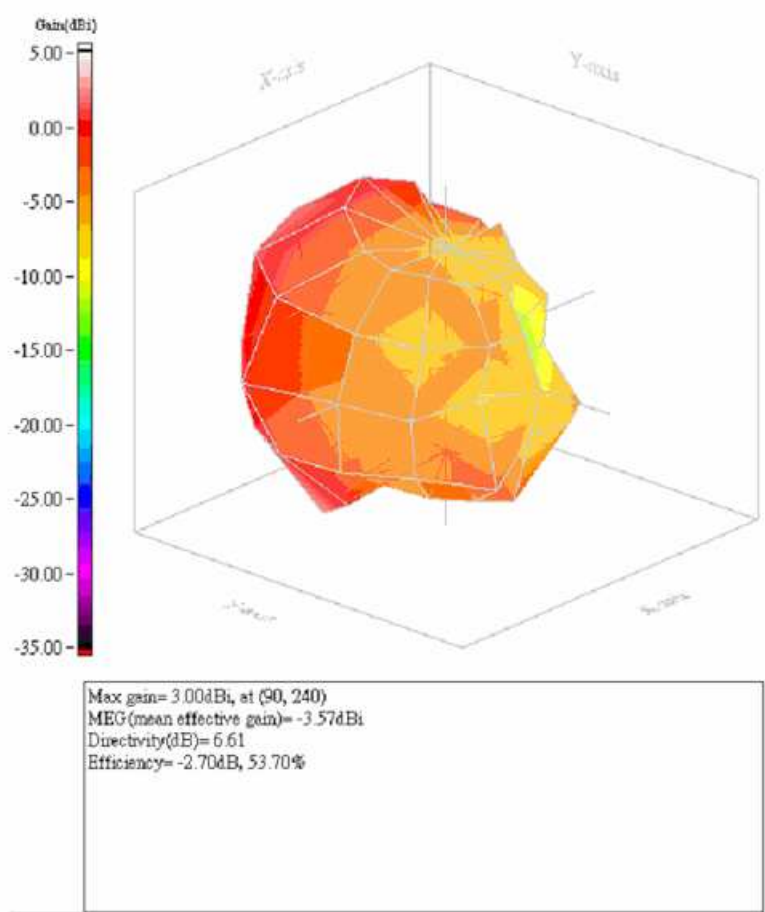

R&D	Print date 10/10/07						
	8010 Ceramic Chip Antenna for Bluetooth/Wimax Application			CAN4311 881 XX 245 3K		June, 2008 v6	
						Aug, 2008 v7	
						Sept, 2008 v8	
Justin Liu	Tommy Chen		Page 9	sheet 190-9		A4	
Oscar Lu	Yageo Taiwan / High Frequency BU						

8. Reliability Test

IEC 384-10/ CECC 32 100 CLAUSE	IEC 60068-2 TEST METHOD	TEST	PROCEDURE	REQUIREMENTS
4.4		Mounting	The antenna can be mounted on printed-circuit boards or ceramic substrates by applying wave soldering, reflow soldering (including vapour phase soldering) or conductive adhesive	No visible damage
4.5		Visual inspection and dimension check	Any applicable method using $\times 10$ magnification	In accordance with specification (chip off 4mm)
4.6.1		Antenna	Central Frequency at 20 °C	Standard test board in page 4
4.8		Adhesion	A force of 3 N applied for 10 s to the line joining the terminations and in a plane parallel to the substrate	No visible damage
4.9		Bond strength of plating on end face	Mounted in accordance with CECC 32 100, paragraph 4.4	No visible damage
			Conditions: bending 0.5 mm at a rate of 1mm/s, radius jig. 340 mm, 2mm warp on FR4 board of 90 mm length	No visible damage
4.10	20(Tb)	Resistance to soldering heat	260 \pm 5 °C for 10 \pm 0.5 s in a static solder bath	Satisfy the original electrical specification after soldering.
		Resistance to leaching	260 \pm 5 °C for 30 \pm 1 s in a static solder bath	Using visual enlargement of $\times 10$, dissolution of the termination shall not exceed 10%

R&D	Print date 10/10/07						
	8010 Ceramic Chip Antenna for Bluetooth/Wimax Application			CAN4311 881 XX 245 3K			June, 2008 v6
							Aug, 2008 v7
							Sept, 2008 v8
Justin Liu Oscar Lu	Tommy Chen			Page 10	sheet 190- 10		A4
Yageo Taiwan / High Frequency BU							

IEC 384-10/ CECC 32 100 CLAUSE	IEC 60068-2 TEST METHOD	TEST	PROCEDURE	REQUIREMENTS
4.11	20(Ta)	Solderability	Zero hour test, and test after storage (20 to 24 months) in original atmosphere; un-mounted chips completely immersed for 2 ± 0.5 s in $235 \pm 5^\circ\text{C}$.	The termination must be well tinned, at least 75% is well tinned at termination
4.12	4(Na)	Rapid change of temperature	-25°C (30 minutes) to $+85^\circ\text{C}$ (30 minutes); 100 cycles	No visible damage Central Freq. Change $\pm 6\%$
4.14	3(Ca)	Damp heat	500 ± 12 hours at 60°C ; 90 to 95 % RH	No visible damage 2 hours recovery Central Freq. Change $\pm 6\%$
4.15		Endurance	500 ± 12 hours at 85°C ;	No visible damage 2 hours recovery Central Freq. Change $\pm 6\%$

■ **Notice (shipping and storage during transportation)**

In order to ensure some quality, it is suggested to follow the condition during shipping :

- Temperature : $-40\sim 70^\circ\text{C}$
- Humidity : $45\sim 75\%$

■ **Notice (storage condition)**

In order to ensure the solderability of the termination, it is suggested to follow the condition for storage :

- Temperature : $15\sim 30^\circ\text{C}$
- Humidity : $45\sim 75\%$
- Prevent corrosive gas (SO_2 , NO_x , NH_3 , Cl_2 , ..etc)
- It is better to use products within 6 months. Solderability should be confirmed again if exceed 6 months.

R&D	Print date 10/10/07						
	8010 Ceramic Chip Antenna for Bluetooth/Wimax Application		CAN4311 881 XX 245 3K			June, 2008 v6	
						Aug, 2008 v7	
						Sept, 2008 v8	
Justin Liu Oscar Lu	Tommy Chen		Page 11	sheet 190- 11			A4
Yageo Taiwan / High Frequency BU							

9. Soldering Condition (Suggestion)

* Customers should alter the profile according to realistic tin paste in use.

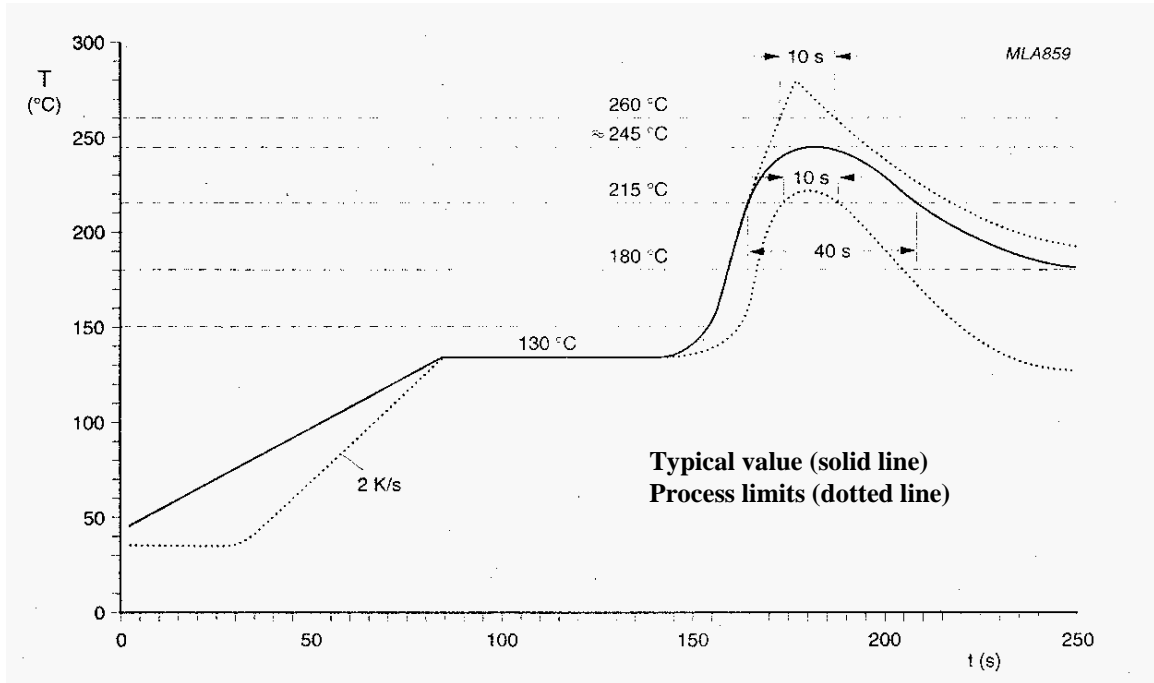

R&D	Print date 10/10/07					
	8010 Ceramic Chip Antenna for Bluetooth/Wimax Application		CAN4311 881 XX 245 3K		June, 2008 v6	
					Aug, 2008 v7	
					Sept, 2008 v8	
Justin Liu Oscar Lu	Tommy Chen		Page 12	sheet 190- 12		A4
Yageo Taiwan / High Frequency BU						

10. Ordering Information

The antennas may be ordered by using the Yageo ordering code. These code numbers can be determined by the following rules:

CAN43 11 8 81 04 245 3K

Family Code

CAN 43 = Yageo Part No. for Antenna

Packing Type Code

11 = 180 mm/ 7" reel , blister taping

Materials Code

8 = High Frequency Material (White)

Size Code

81 = 8.0 * 1.0 * 1.0 mm

Antenna type

- 01** = type 1
- 02** = type 2
- 03** = type 3
- 04** = type 4
- 05** = type 5
- 06** = type 6
- 07** = type 7
- 08** = type 8

Working Frequency

245 = 2.45 GHz

Packing Type Code

3K = 3000 pcs for taping per reel

R&D	Print date 10/10/07						
	8010 Ceramic Chip Antenna for Bluetooth/Wimax Application		CAN4311 881 XX 245 3K			June, 2008 v6	
						Aug, 2008 v7	
						Sept, 2008 v8	
Justin Liu Oscar Lu	Tommy Chen		Page 13	sheet 190- 13			A4
Yageo Taiwan / High Frequency BU							

11. Taping Blister Tape

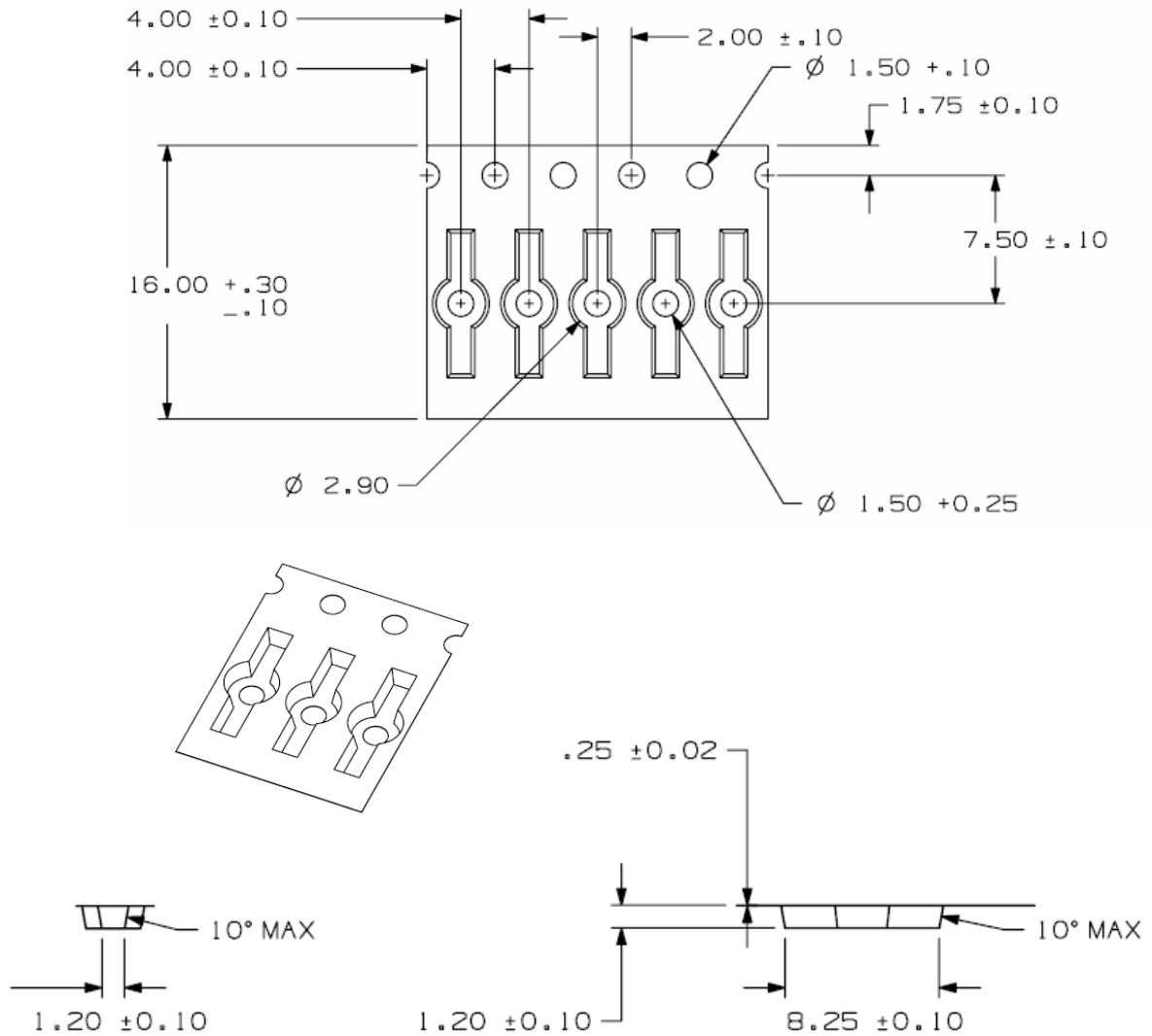

R&D	Print date 10/10/07				
	8010 Ceramic Chip Antenna for Bluetooth/Wimax Application		CAN4311 881 XX 245 3K		June, 2008 v6
					Aug, 2008 v7
					Sept, 2008 v8
Justin Liu Oscar Lu	Tommy Chen		Page 14	sheet 190- 14	A4
Yageo Taiwan / High Frequency BU					

12. Taping Reel - 7"(180mm) Specifications

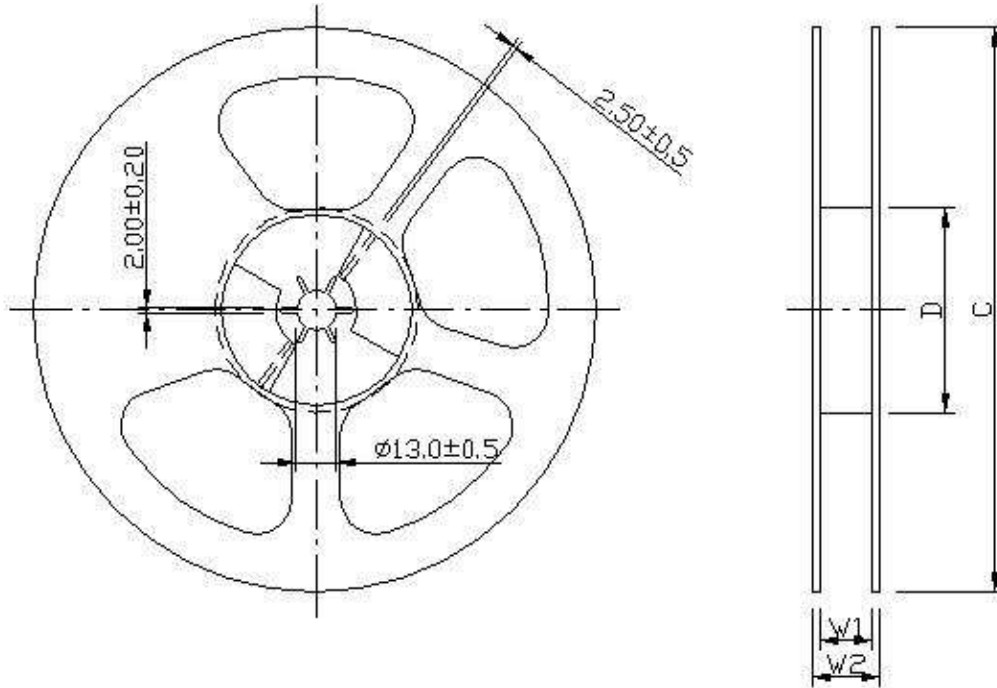

Product size code	Units per Reel	Tape Width (mm)	C (mm)	D (mm)	W ₁ (mm)	W ₂ (mm)
Antenna	1000	16	180.0±1.0	62±0.5	16.0±1.0	20.5±1.0

R&D	Print date 10/10/07					
	8010 Ceramic Chip Antenna for Bluetooth/Wimax Application		CAN4311 881 XX 245 3K			June, 2008 v6
						Aug, 2008 v7
						Sept, 2008 v8
Justin Liu Oscar Lu	Tommy Chen		Page 15	sheet 190- 15		A4
Yageo Taiwan / High Frequency BU						

11. Tape Revision Control:

Revision	Date	Content	Remark
V6	June, 2008	Phase out Blue series	
V7	Aug, 2008	Modify the dimension of soldering pad	
V8	Sept, 2008	Modify the dimension of soldering pad	
V9	Sept, 2008	Modify the operation temperature	

R&D	Print date 10/10/07						
	8010 Ceramic Chip Antenna for Bluetooth/Wimax Application			CAN4311 881 XX 245 3K			June, 2008 v6
							Aug, 2008 v7
							Sept, 2008 v8
Justin Liu Oscar Lu	Tommy Chen			Page 16	sheet 190- 16		A4
Yageo Taiwan / High Frequency BU							