



CTC Laboratories, Inc.

1-2/F., Building 2, Jiaquan Building, Guanlan High-Tech Park, Shenzhen, Guangdong, China
Tel: +86-755- 27521059 Fax: +86-755- 27521011 Http://www.sz-ctc.org.cn

TEST REPORT

Report No.: **CTC20210728E12**

FCC ID.....: **XUJX431PROV5**

Applicant.....: **Launch Tech Co., Ltd.**

Address.....: Launch Industrial Park, North of Wuhe Avenue, Banxuegang, Longgang, Shenzhen, Guangdong, P.R. China

Manufacturer.....: Launch Tech Co., Ltd.

Address.....: Launch Industrial Park, North of Wuhe Avenue, Banxuegang, Longgang, Shenzhen, Guangdong, P.R. China

Product Name.....: **AUTO Smart Diagnostic Tool**

Trade Mark.....: LAUNCH

Model/Type reference.....: X-431 PRO3 V5.0, X-431 PRO V5.0

Listed Model(s): X-431 V+ V5.0, X-431 PRO5 V2.0, X-431 V V5.0, X-431 IMMO Pro

Standard.....: **FCC CFR Title 47 Part 15 Subpart C Section 15.247**

Date of receipt of test sample...: Apr. 13, 2021

Date of testing.....: Apr. 14, 2021 ~ Jul. 06, 2021

Date of issue.....: Jul. 07, 2021

Result.....: **PASS**

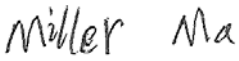
Compiled by:		
(Printed name+signature)	Terry Su	
Supervised by:		
(Printed name+signature)	Miller Ma	
Approved by:		
(Printed name+signature)	Walter Chen	

Testing Laboratory Name.....: **CTC Laboratories, Inc.**

Address.....: 1-2/F., Building 2, Jiaquan Building, Guanlan High-Tech Park, Shenzhen, Guangdong, China

This test report may be duplicated completely for legal use with the approval of the applicant. It should not be reproduced except in full, without the written approval of our laboratory. The client should not use it to claim product endorsement by CTC. The test results in the report only apply to the tested sample. The test report shall be invalid without all the signatures of testing engineers, reviewer and approver. Any objections must be raised to CTC within 15 days since the date when the report is received. It will not be taken into consideration beyond this limit. The test report merely correspond to the test sample.



Table of Contents

Page

1. TEST SUMMARY.....	3
1.1. TEST STANDARDS.....	3
1.2. REPORT VERSION.....	3
1.3. TEST DESCRIPTION.....	4
1.4. TEST FACILITY.....	5
1.5. MEASUREMENT UNCERTAINTY.....	5
1.6. ENVIRONMENTAL CONDITIONS.....	6
2. GENERAL INFORMATION.....	7
2.1. CLIENT INFORMATION.....	7
2.2. GENERAL DESCRIPTION OF EUT.....	8
2.3. ACCESSORY EQUIPMENT INFORMATION.....	8
2.4. OPERATION STATE.....	10
2.5. MEASUREMENT INSTRUMENTS LIST.....	11
3. TEST ITEM AND RESULTS.....	13
3.1. CONDUCTED EMISSION.....	13
3.2. RADIATED EMISSION.....	16
3.3. BAND EDGE EMISSIONS (RADIATED).....	38
3.4. BAND EDGE AND SPURIOUS EMISSIONS (CONDUCTED).....	51
3.5. 20DB BANDWIDTH.....	66
3.6. CHANNEL SEPARATION.....	70
3.7. NUMBER OF HOPPING CHANNEL.....	75
3.8. DWELL TIME.....	77
3.9. PEAK OUTPUT POWER.....	82
3.10. DUTY CYCLE.....	86
3.11. ANTENNA REQUIREMENT.....	90



1. TEST SUMMARY

1.1. Test Standards

The tests were performed according to following standards:

[FCC Rules Part 15.247](#): Operation within the bands of 902-928MHz, 2400-2483.5MHz, and 5725-5850MHz.

[RSS 247 Issue 2](#): Standard Specifications for Frequency Hopping Systems (FHSs) and Digital Transmission Systems (DTSs) Operating in the Bands 902-928MHz, 2400-2483.5MHz and 5725-5850MHz.

[ANSI C63.10-2013](#): American National Standard for Testing Unlicensed Wireless Devices.

1.2. Report version

Revised No.	Date of issue	Description
01	Jul. 07, 2021	Original



1.3. Test Description

FCC Part 15 Subpart C (15.247)/ RSS 247 Issue 2				
Test Item	Standard Section		Result	Test Engineer
	FCC	IC		
Antenna Requirement	15.203	/	Pass	Rod Luo
Conducted Emission	15.207	RSS-Gen 8.8	Pass	Eva Feng
Restricted Bands	15.205	RSS-Gen 8.10	Pass	Rod Luo
Hopping Channel Separation	15.247(a)(1)	RSS 247 5.1 (b)	Pass	Rod Luo
Dwell Time	15.247(a)(iii)	RSS 247 5.1 (d)	Pass	Rod Luo
Peak Output Power	15.247(b)(1)	RSS 247 5.4 (b)	Pass	Rod Luo
Number of Hopping Frequency	15.247(a)(iii)	RSS 247 5.1 (d)	Pass	Rod Luo
Conducted Band Edge and Spurious Emissions	15.247(d)	RSS 247 5.5	Pass	Rod Luo
Radiated Band Edge and Spurious Emissions	15.205&15.209&15.247(d)	RSS 247 5.5	Pass	Rod Luo
Radiated Spurious Emission	15.247(d)&15.209	RSS 247 5.5&RSS-Gen 8.9	Pass	Rod Luo
20dB Bandwidth	15.247(a)	RSS 247 5.1 (b)	Pass	Rod Luo

Note: The measurement uncertainty is not included in the test result.



1.4. Test Facility

CTC Laboratories, Inc.

Add: 1-2/F., Building 2, Jiaquan Building, Guanlan High-Tech Park, Shenzhen, Guangdong, China

Laboratory accreditation

The test facility is recognized, certified, or accredited by the following organizations:

CNAS-Lab Code: L5365

CTC Laboratories, Inc. has been assessed and proved to be in compliance with CNAS-CL01 Accreditation. Criteria for Testing and Calibration Laboratories (identical to ISO/IEC 17025:2017 General Requirements) for the Competence of Testing and Calibration Laboratories.

A2LA-Lab Cert. No.: 4340.01

CTC Laboratories, Inc. EMC Laboratory has been accredited by A2LA for technical competence in the field of electrical testing, and proved to be in compliance with ISO/IEC 17025:2017 General Requirements for the Competence of Testing and Calibration Laboratories and any additional program requirements in the identified field of testing.

Industry Canada (Registration No.: 9783A, CAB Identifier: CN0029)

CTC Laboratories, Inc. EMC Laboratory has been registered by Certification and Engineer Bureau of Industry Canada for the performance of with Registration NO.: 9783A on Jan, 2016.

FCC (Registration No.: 951311, Designation Number CN1208)

CTC Laboratories, Inc. EMC Laboratory has been registered and fully described in a report filed with the (FCC) Federal Communications Commission. The acceptance letter from the FCC is maintained in our files. Registration 951311, Aug 26, 2017.

1.5. Measurement Uncertainty

The data and results referenced in this document are true and accurate. The reader is cautioned that there may be errors within the calibration limits of the equipment and facilities. The measurement uncertainty was calculated for all measurements listed in this test report acc. to TR-100028-01 "Electromagnetic compatibility and Radio spectrum Matters (ERM); Uncertainties in the measurement of mobile radio equipment characteristics; Part 1" and TR-100028-02 "Electromagnetic compatibility and Radio spectrum Matters (ERM); Uncertainties in the measurement of mobile radio equipment characteristics; Part 2" and is documented in the CTC Laboratories, Inc. quality system acc. to DIN EN ISO/IEC 17025. Furthermore, component and process variability of devices similar to that tested may result in additional deviation. The manufacturer has the sole responsibility of continued compliance of the device.

Below is the best measurement capability for CTC Laboratories, Inc.



Test Items	Measurement Uncertainty	Notes
Transmitter power conducted	0.42 dB	(1)
Transmitter power Radiated	2.14 dB	(1)
Conducted spurious emissions 9kHz~40GHz	1.60 dB	(1)
Radiated spurious emissions 9kHz~40GHz	2.20 dB	(1)
Conducted Emissions 9kHz~30MHz	3.08 dB	(1)
Radiated Emissions 30~1000MHz	4.51 dB	(1)
Radiated Emissions 1~18GHz	5.84 dB	(1)
Radiated Emissions 18~40GHz	6.12 dB	(1)
Occupied Bandwidth	-----	(1)

Note (1): This uncertainty represents an expanded uncertainty expressed at approximately the 95% confidence level using a coverage factor of $k=1.96$.

1.6. Environmental conditions

During the measurement the environmental conditions were within the listed ranges:

Temperature:	21°C ~ 27°C
Relative Humidity:	40% ~ 60%
Air Pressure:	101kPa



2. GENERAL INFORMATION

2.1. Client Information

Applicant:	Launch Tech Co., Ltd.
Address:	Launch Industrial Park, North of Wuhe Avenue, Banxuegang, Longgang, Shenzhen, Guangdong, P.R. China
Manufacturer:	Launch Tech Co., Ltd.
Address:	Launch Industrial Park, North of Wuhe Avenue, Banxuegang, Longgang, Shenzhen, Guangdong, P.R. China



2.2. General Description of EUT

Product Name:	AUTO Smart Diagnostic Tool
Trade Mark:	LAUNCH
Model/Type reference:	X-431 PRO3 V5.0, X-431 PRO V5.0
Listed Model(s):	X-431 V+ V5.0, X-431 PRO5 V2.0, X-431 V V5.0, X-431 IMMO Pro
Model Difference:	All these models are identical in the same PCB, Layout and electrical circuit, The only difference is screen size, model name, colour of shell and rubber sleeve, antenna position, X-431 PRO3 V5.0, X-431 V+ V5.0, X-431 PRO5 V2.0 with an internal roll guard, X-431 PRO V5.0, X-431 V V5.0, X-431 IMMO Pro does without a roll guard.
Power supply:	5Vdc/5A from AC/DC Adapter 7.6Vdc from 6300mAh Li-ion Battery
Adapter model:	PSYC0505000US Input: 100-240V~ 50/60Hz 0.6A Max Output: 5Vdc/5A
Hardware version:	BSK-Y12-V3
Software version:	V1.1.4
Bluetooth 5.1/EDR	
Modulation:	GFSK, $\pi/4$ -DQPSK, 8-DPSK
Operation frequency:	2402MHz~2480MHz
Channel number:	79
Channel separation:	1MHz
Antenna type:	FPC Antenna
X-431 PRO3 V5.0 Antenna gain:	2dBi
X-431 PRO V5.0 Antenna gain:	2.3dBi

Note: X-431 PRO3 V5.0, X-431 PRO V5.0 has been testes, Just the worst case recorded in report.



2.3. Accessory Equipment information

Equipment Information			
Name	Model	S/N	Manufacturer
/	/	/	/
/	/	/	/

Cable Information			
Name	Shielded Type	Ferrite Core	Length
/	/	/	/

Test Software Information			
Name			
Engineering mode	/	/	/



2.4. Operation state

Operation Frequency List: The EUT has been tested under typical operating condition. The Applicant provides communication tools software to control the EUT for staying in continuous transmitting and receiving mode for testing. BT EDR, 79 channels are provided to the EUT. Channels 00/39/78 were selected for testing.

Operation Frequency List:

Channel	Frequency (MHz)
00	2402
01	2403
:	:
38	2440
39	2441
40	2442
:	:
77	2479
78	2480

Note: The display in grey were the channel selected for testing.

Test mode

For RF test items:
The engineering test program was provided and enabled to make EUT continuous transmit
For AC power line conducted emissions:
The EUT was set to connect with the Bluetooth instrument under large package sizes transmission.
For Radiated spurious emissions test item:
The engineering test program was provided and enabled to make EUT continuous transmit. The EUT in each of three orthogonal axis emissions had been tested, but only the worst case (X axis) data recorded in the report.





2.5. Measurement Instruments List

Tonscend JS0806-2 Test system					
Item	Test Equipment	Manufacturer	Model No.	Serial No.	Calibrated until
1	Spectrum Analyzer	Rohde & Schwarz	FSU26	100105	Dec. 25, 2021
2	Spectrum Analyzer	Rohde & Schwarz	FUV40-N	101331	Mar. 15, 2022
3	MXG Vector Signal Generator	Agilent	N5182A	MY47420864	Dec. 25, 2021
4	Signal Generator	Agilent	E8257D	MY46521908	Dec. 25, 2021
5	Power Sensor	Agilent	U2021XA	MY5365004	Dec. 25, 2021
6	Power Sensor	Agilent	U2021XA	MY5365006	Dec. 25, 2021
7	Simultaneous Sampling DAQ	Agilent	U2531A	TW54493510	Dec. 25, 2021
8	Climate Chamber	TABAI	PR-4G	A8708055	Dec. 25, 2021
9	Wideband Radio Communication Tester	Rohde & Schwarz	CMW500	116410	Dec. 25, 2021
10	Climate Chamber	ESPEC	MT3065	/	Dec. 25, 2021
11	Wideband Radio Communication Tester	Rohde & Schwarz	CMW500	116410	Dec. 25, 2021
12	300328 v2.2.2 test system	TONSCEND	v2.6	/	/

Radiated Emission and Transmitter spurious emissions					
Item	Test Equipment	Manufacturer	Model No.	Serial No.	Calibrated until
1	EMI Test Receiver	Rohde & Schwarz	ESCI	100658	Dec. 25, 2021
2	High pass filter	micro-tranics	HPM50111	142	Dec. 25, 2021
3	Log-Bicon Antenna	Schwarzbeck	CBL6141A	4180	Dec. 25, 2021
4	Ultra-Broadband Antenna	ShwarzBeck	BBHA9170	25841	Dec. 25, 2021
5	Loop Antenna	LAPLAC	RF300	9138	Dec. 25, 2021
6	Spectrum Analyzer	Rohde & Schwarz	FSU26	100105	Dec. 25, 2021
7	Horn Antenna	Schwarzbeck	BBHA 9120D	647	Dec. 25, 2021
8	Pre-Amplifier	HP	8447D	1937A03050	Dec. 25, 2021
9	Pre-Amplifier	EMCI	EMC051835	980075	Dec. 25, 2021
10	Antenna Mast	UC	UC3000	N/A	N/A
11	Turn Table	UC	UC3000	N/A	N/A
12	Cable Below 1GHz	Schwarzbeck	AK9515E	33155	Dec. 25, 2021
13	Cable Above 1GHz	Hubersuhner	SUCOFLEX102	DA1580	Dec. 25, 2021
14	Splitter	Mini-Circuit	ZAPD-4	400059	Dec. 25, 2021
15	RF Connection Cable	HUBER+SUHNER	RE-7-FL	N/A	Dec. 25, 2021

CTC Laboratories, Inc.

1-2/F., Building 2, Jiaquan Building, Guanlan High-Tech Park, Shenzhen, Guangdong, China

Tel.: (86)755-27521059

Fax: (86)755-27521011

Http://www.sz-ctc.org.cn

For anti-fake verification, please visit the official website of Certification and Accreditation Administration of the People's Republic of China : yz.cnca.cn



16	RF Connection Cable	Chengdu E-Microwave	---	---	Dec. 25, 2021
17	High pass filter	Compliance Direction systems	BSU-6	34202	Dec. 25, 2021
18	Attenuator	Chengdu E-Microwave	EM-CAXX-10RNZ-3	---	Dec. 25, 2021
19	High and low temperature box	ESPEC	MT3065	12114019	Dec. 25, 2021

Conducted Emission					
Item	Test Equipment	Manufacturer	Model No.	Serial No.	Calibrated until
1	LISN	Rohde & Schwarz	ENV216	101112	Dec. 25, 2021
2	LISN	Rohde & Schwarz	ENV216	101113	Dec. 25, 2021
3	EMI Test Receiver	Rohde & Schwarz	ESCI	100658	Dec. 25, 2021

Note:1. The Cal. Interval was one year.

2. The cable loss has calculated in test result which connection between each test instruments.

3. TEST ITEM AND RESULTS

3.1. Conducted Emission

Limit

FCC CFR Title 47 Part 15 Subpart C Section 15.207/ RSS – Gen 8.8

Frequency range (MHz)	Limit (dBuV)	
	Quasi-peak	Average
0.15-0.5	66 to 56*	56 to 46*
0.5-5	56	46
5-30	60	50

* Decreases with the logarithm of the frequency.

Test Configuration

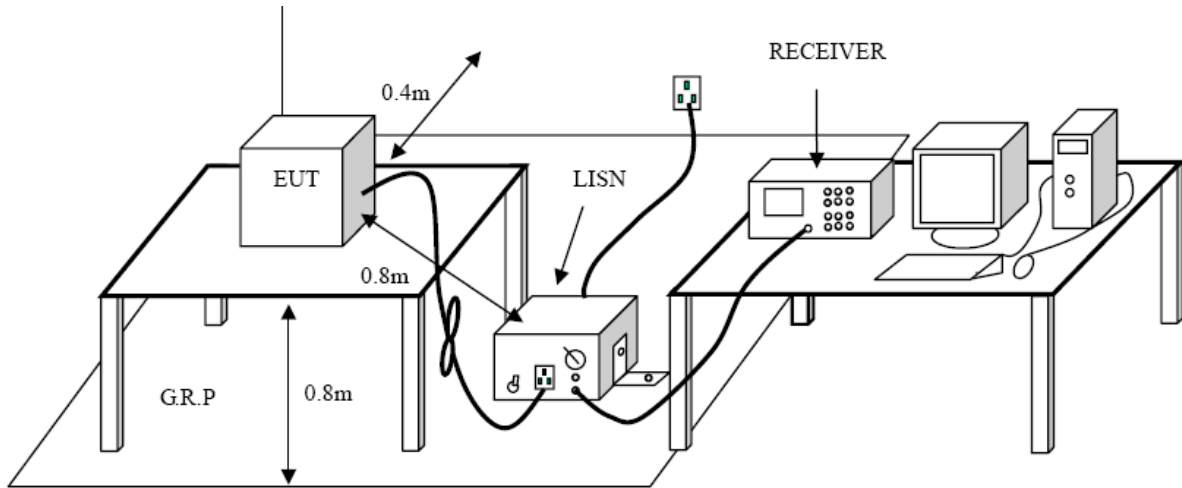

Test Procedure

1. The EUT was setup according to ANSI C63.10:2013 requirements.
2. The EUT was placed on a platform of nominal size, 1 m by 1.5 m, raised 80 cm above the conducting ground plane. The vertical conducting plane was located 40 cm to the rear of the EUT. All other surfaces of EUT were at least 80 cm from any other grounded conducting surface.
3. The EUT and simulators are connected to the main power through a line impedances stabilization network (LISN). The LISN provides a 50ohm /50uH coupling impedance for the measuring equipment. The peripheral devices are also connected to the main power through a LISN. (Please refer to the block diagram of the test setup and photographs)
4. Each current-carrying conductor of the EUT power cord, except the ground (safety) conductor, was individually connected through a LISN to the input power source.
5. The excess length of the power cord between the EUT and the LISN receptacle were folded back and forth at the center of the lead to form a bundle not exceeding 40 cm in length.
6. Conducted Emissions were investigated over the frequency range from 0.15MHz to 30MHz using a receiver bandwidth of 9 kHz.
7. During the above scans, the emissions were maximized by cable manipulation.

Test Mode

Please refer to the clause 2.4.



Test Results

Test Voltage:	AC 120V/60 Hz
Terminal:	Line

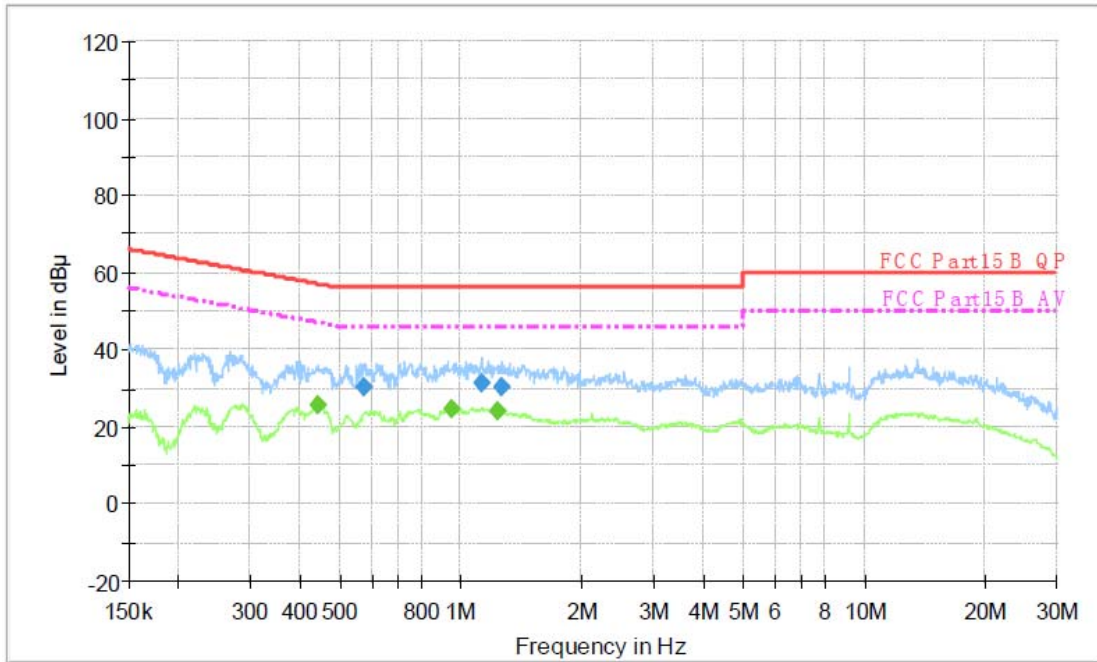

Final Measurement Detector 1

Frequency (MHz)	QuasiPeak (dBµ V)	Meas. Time (ms)	Bandwidth (kHz)	Filter	Line	Corr. (dB)	Margin (dB)	Limit (dBµ V)	Comment
0.578210	30.3	1000.00	9.000	On	L1	10.1	25.7	56.0	
1.121720	31.2	1000.00	9.000	On	L1	10.2	24.8	56.0	
1.259390	30.5	1000.00	9.000	On	L1	10.2	25.5	56.0	

Final Measurement Detector 2

Frequency (MHz)	Average (dBµ V)	Meas. Time (ms)	Bandwidth (kHz)	Filter	Line	Corr. (dB)	Margin (dB)	Limit (dBµ V)	Comment
0.440750	25.8	1000.00	9.000	On	L1	10.1	21.2	47.0	
0.952360	24.6	1000.00	9.000	On	L1	10.2	21.4	46.0	
1.229580	24.3	1000.00	9.000	On	L1	10.2	21.7	46.0	

Emission Level= Read Level+ Correct Factor



Test Voltage:	AC 120V/60 Hz
Terminal:	Neutral

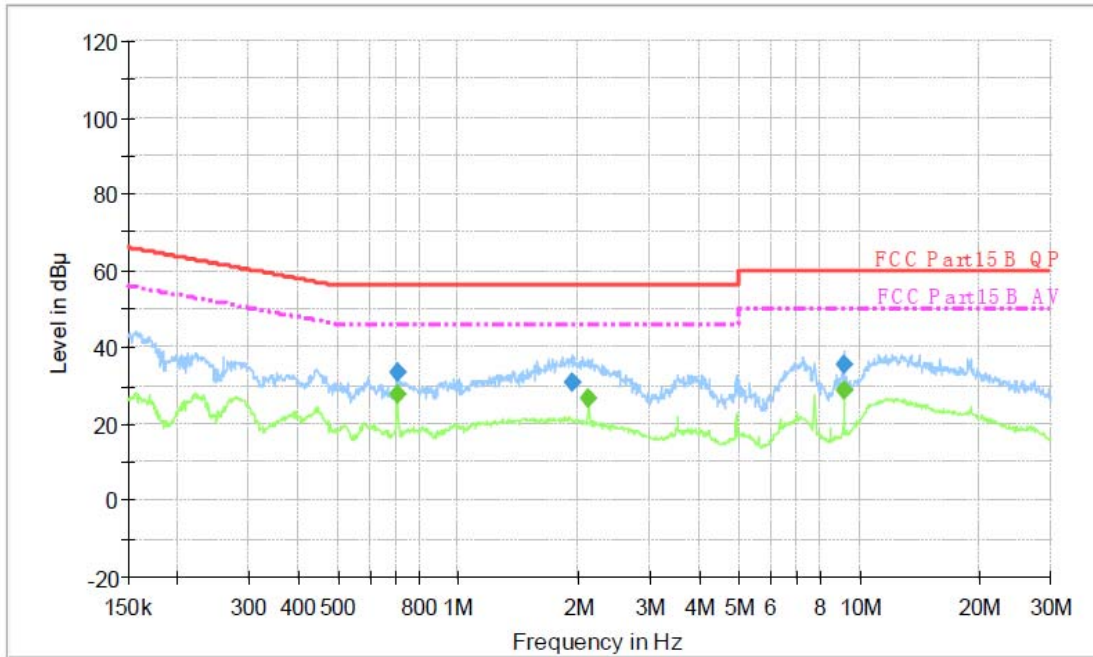

Final Measurement Detector 1

Frequency (MHz)	QuasiPeak (dBµ V)	Meas. Time (ms)	Bandwidth (kHz)	Filter	Line	Corr. (dB)	Margin (dB)	Limit (dBµ V)	Comment
0.703130	33.6	1000.00	9.000	On	N	10.1	22.4	56.0	
1.915140	30.8	1000.00	9.000	On	N	10.2	25.2	56.0	
9.158320	35.6	1000.00	9.000	On	N	10.4	24.4	60.0	

Final Measurement Detector 2

Frequency (MHz)	Average (dBµ V)	Meas. Time (ms)	Bandwidth (kHz)	Filter	Line	Corr. (dB)	Margin (dB)	Limit (dBµ V)	Comment
0.703130	27.6	1000.00	9.000	On	N	10.1	18.4	46.0	
2.116130	26.6	1000.00	9.000	On	N	10.2	19.4	46.0	
9.158320	28.6	1000.00	9.000	On	N	10.4	21.4	50.0	

Emission Level= Read Level+ Correct Factor

3.2. Radiated Emission

Limit

FCC CFR Title 47 Part 15 Subpart C Section 15.209/ RSS – Gen 8.9

Frequency	Limit (dBuV/m @3m)	Value
30 MHz ~ 88 MHz	40.00	Quasi-peak
88 MHz ~ 216 MHz	43.50	Quasi-peak
216 MHz ~ 960 MHz	46.00	Quasi-peak
960 MHz ~ 1 GHz	54.00	Quasi-peak
Above 1 GHz	54.00	Average
	74.00	Peak

Note:

- (1) The tighter limit applies at the band edges.
- (2) Emission Level (dBuV/m)=20log Emission Level (uV/m).

Test Configuration

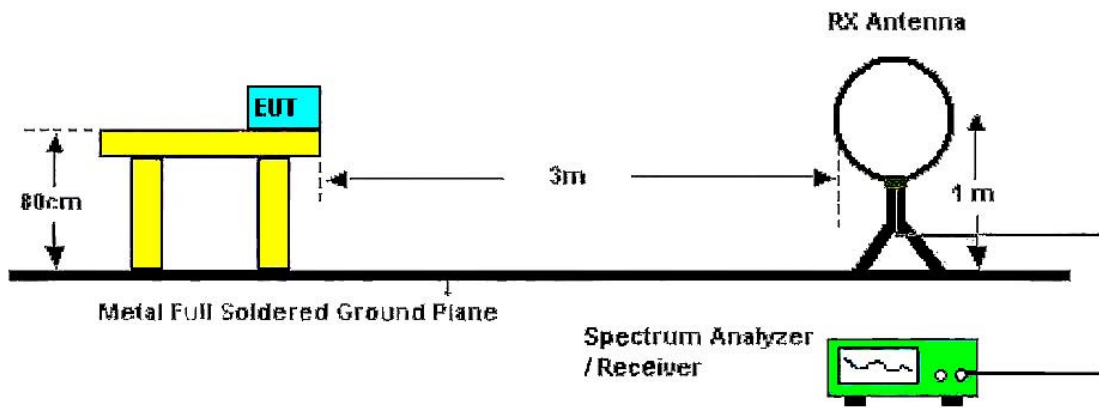

Below 30MHz Test Setup

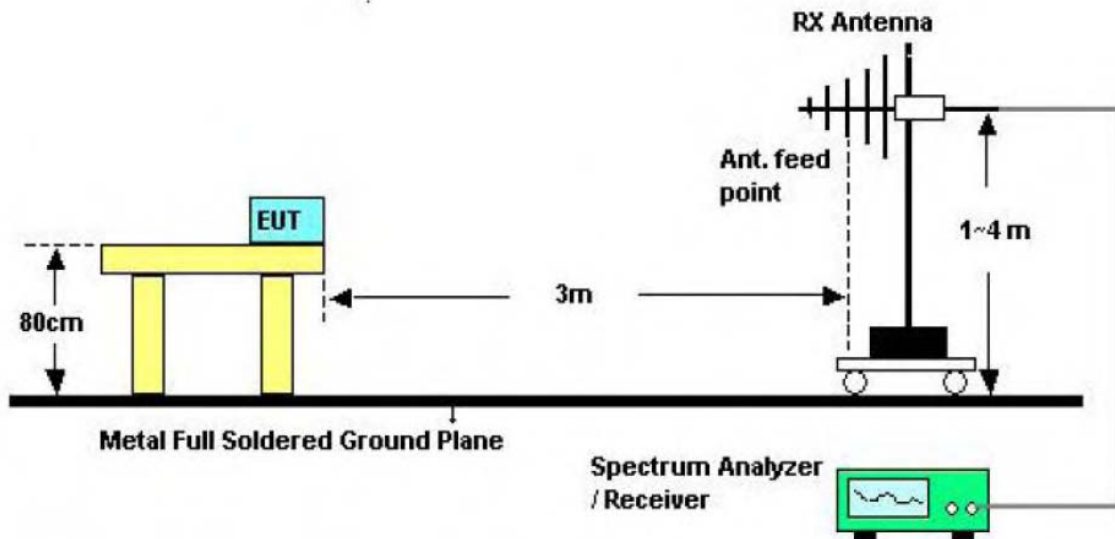

Below 1000MHz Test Setup

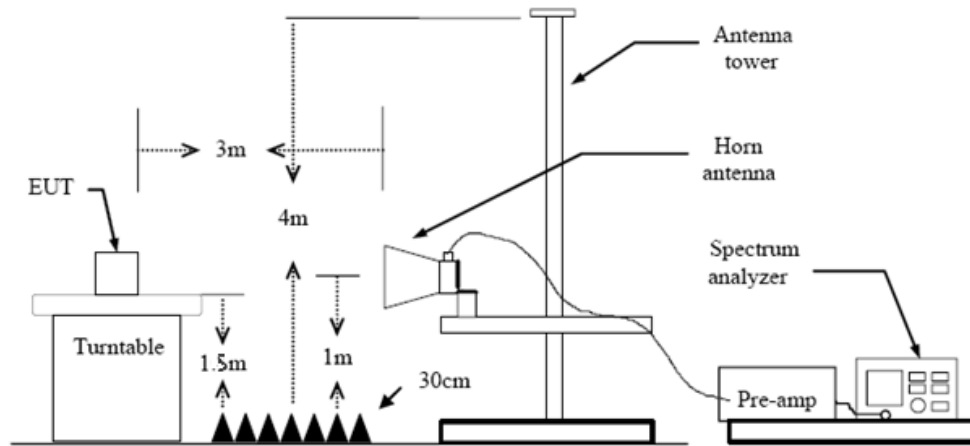

Above 1GHz Test Setup

Test Procedure

1. The EUT was setup and tested according to ANSI C63.10:2013
2. The EUT is placed on a turn table which is 0.8 meter above ground for below 1 GHz, and 1.5 m for above 1 GHz. The turn table is rotated 360 degrees to determine the position of the maximum emission level.
3. The EUT was set 3 meters from the receiving antenna, which was mounted on the top of a variable height antenna tower.
4. For each suspected emission, the EUT was arranged to its worst case and then tune the Antenna tower (from 1 m to 4 m) and turntable (from 0 degree to 360 degrees) to find the maximum reading. A pre-amp and a high pass filter are used for the test in order to get better signal level to comply with the guidelines.
5. Set to the maximum power setting and enable the EUT transmit continuously.
6. Use the following spectrum analyzer settings
 - (1) Span shall wide enough to fully capture the emission being measured;
 - (2) Below 1 GHz:
RBW=120 kHz, VBW=300 kHz, Sweep=auto, Detector function=peak, Trace=max hold;
If the emission level of the EUT measured by the peak detector is 3 dB lower than the applicable limit, the peak emission level will be reported. Otherwise, the emission measurement will be repeated using the quasi-peak detector and reported.
 - (3) From 1 GHz to 10th harmonic:
RBW=1MHz, VBW=3MHz Peak detector for Peak value.
RBW=1MHz, VBW \geq 1/T Peak detector for Average value.Note 1: For the 1/T& Duty Cycle please refer to clause 3.10 Duty Cycle.

Test Mode

Please refer to the clause 2.4.

Test Result

9 KHz~30 MHz

From 9 KHz to 30 MHz: Conclusion: PASS

Note: The amplitude of spurious emissions which are attenuated by more than 20dB below the permissible value has no need to be reported.



30MHz-1GHz

Ant. Pol.	Horizontal
Test Mode:	TX GFSK Mode 2402MHz
Remark:	Only worse case is reported

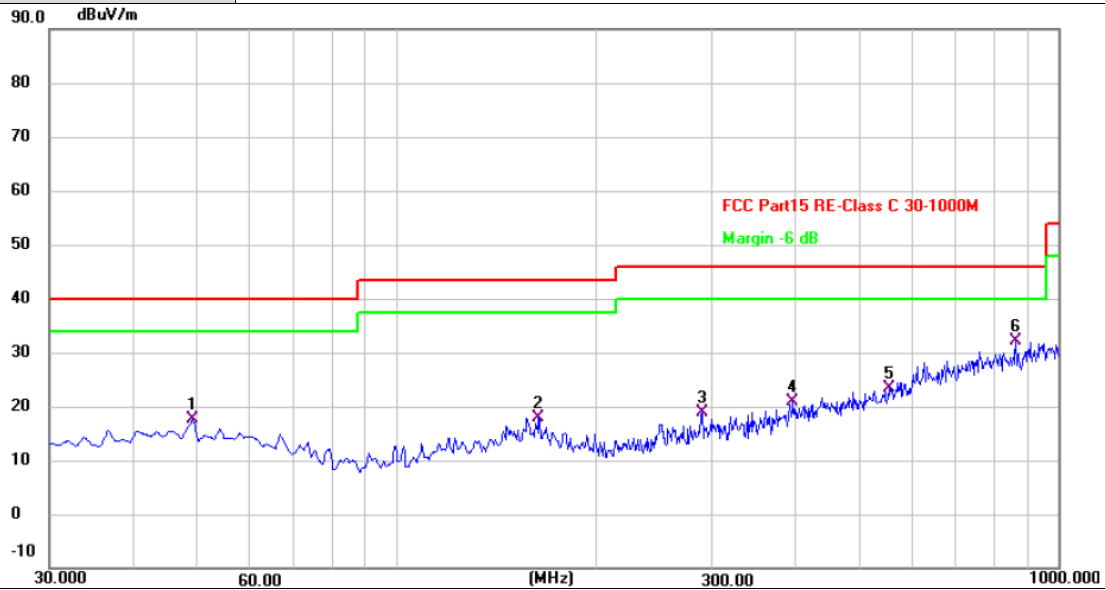

No.	Frequency (MHz)	Reading (dBuV)	Factor (dB/m)	Level (dBuV/m)	Limit (dBuV/m)	Margin (dB)	Detector
1	49.4000	32.34	-14.60	17.74	40.00	-22.26	QP
2	164.8300	32.58	-14.65	17.93	43.50	-25.57	QP
3	290.9300	33.46	-14.70	18.76	46.00	-27.24	QP
4	398.6000	32.85	-11.88	20.97	46.00	-25.03	QP
5	555.7400	31.26	-8.00	23.26	46.00	-22.74	QP
6 *	864.2000	34.17	-2.13	32.04	46.00	-13.96	QP

Remarks:

1. Factor (dB/m) = Antenna Factor (dB/m)+Cable Factor (dB)-Pre-amplifier Factor
2. Margin value = Level -Limit value



Ant. Pol.	Vertical
Test Mode:	TX GFSK Mode 2402MHz
Remark:	Only worse case is reported

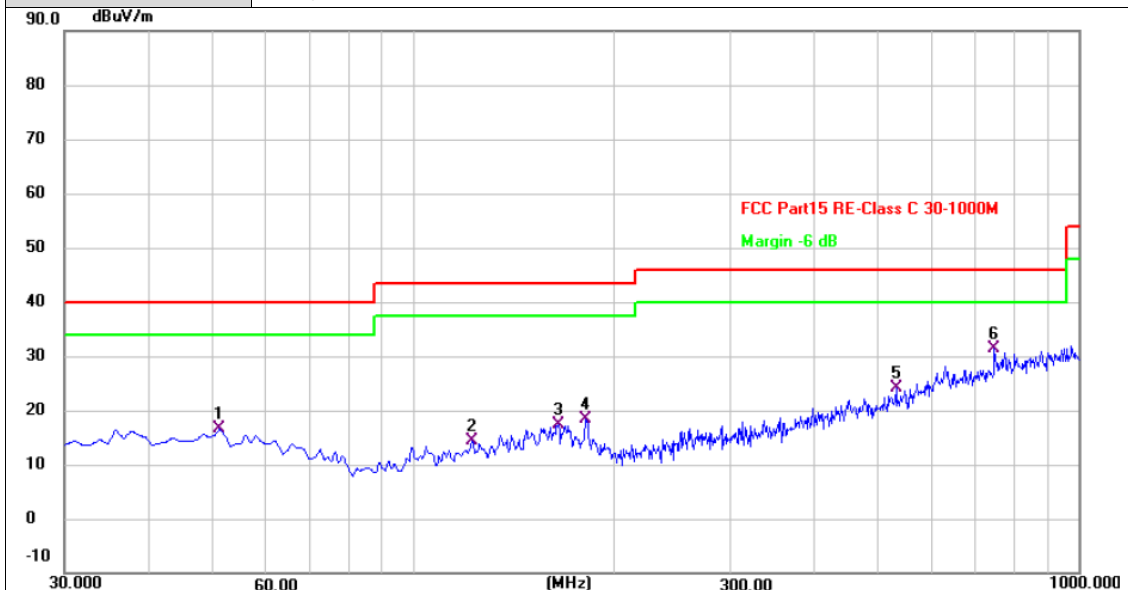

No.	Frequency (MHz)	Reading (dBuV)	Factor (dB/m)	Level (dBuV/m)	Limit (dBuV/m)	Margin (dB)	Detector
1	51.3400	31.25	-14.72	16.53	40.00	-23.47	QP
2	123.1200	30.69	-16.20	14.49	43.50	-29.01	QP
3	165.8000	32.03	-14.66	17.37	43.50	-26.13	QP
4	182.2899	34.93	-16.46	18.47	43.50	-25.03	QP
5	532.4600	32.94	-8.79	24.15	46.00	-21.85	QP
6 *	749.7400	35.02	-3.73	31.29	46.00	-14.71	QP

Remarks:

- 1.Factor (dB/m) = Antenna Factor (dB/m)+Cable Factor (dB)-Pre-amplifier Factor
- 2.Margin value = Level -Limit value



Above 1GHz

Ant. Pol.	Horizontal
Test Mode:	TX GFSK Mode 2402MHz
Remark:	No report for the emission which more than 10 dB below the pre-scribed limit.

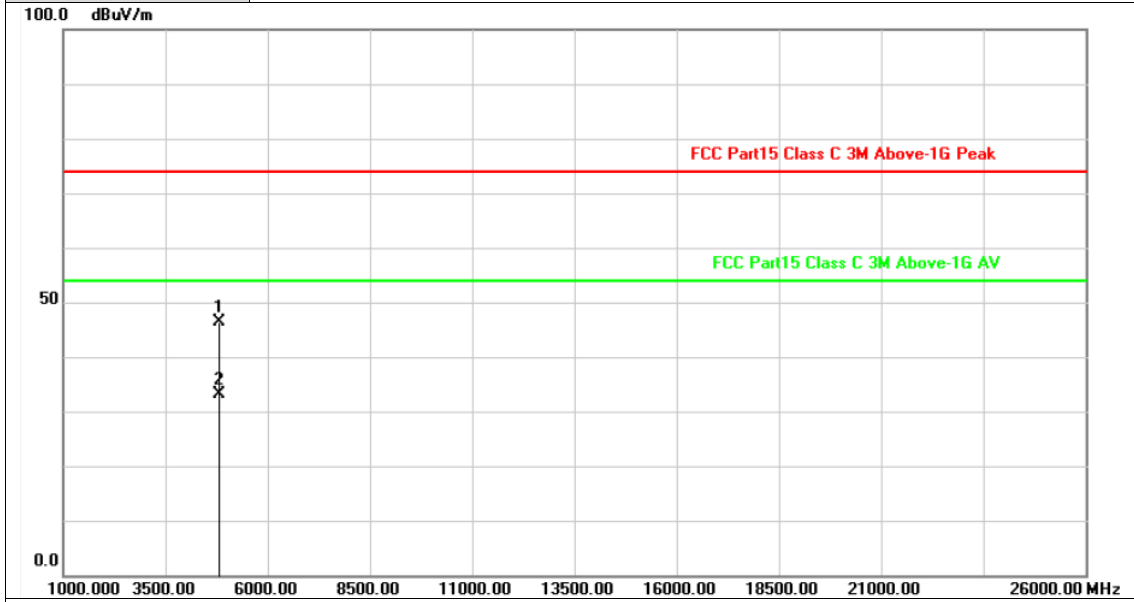

No.	Frequency (MHz)	Factor (dB/m)	Reading (dBuV)	Level (dBuV/m)	Limit (dBuV/m)	Margin (dB)	Detector
1	4803.474	-2.82	49.12	46.30	74.00	-27.70	peak
2	4804.562	-2.82	36.07	33.25	54.00	-20.75	AVG

Remarks:
 1. Factor (dB/m) = Antenna Factor (dB/m)+Cable Factor (dB)-Pre-amplifier Factor
 2. Margin value = Level -Limit value



Ant. Pol.	Vertical
Test Mode:	TX GFSK Mode 2402MHz
Remark:	No report for the emission which more than 10 dB below the prescribed limit.

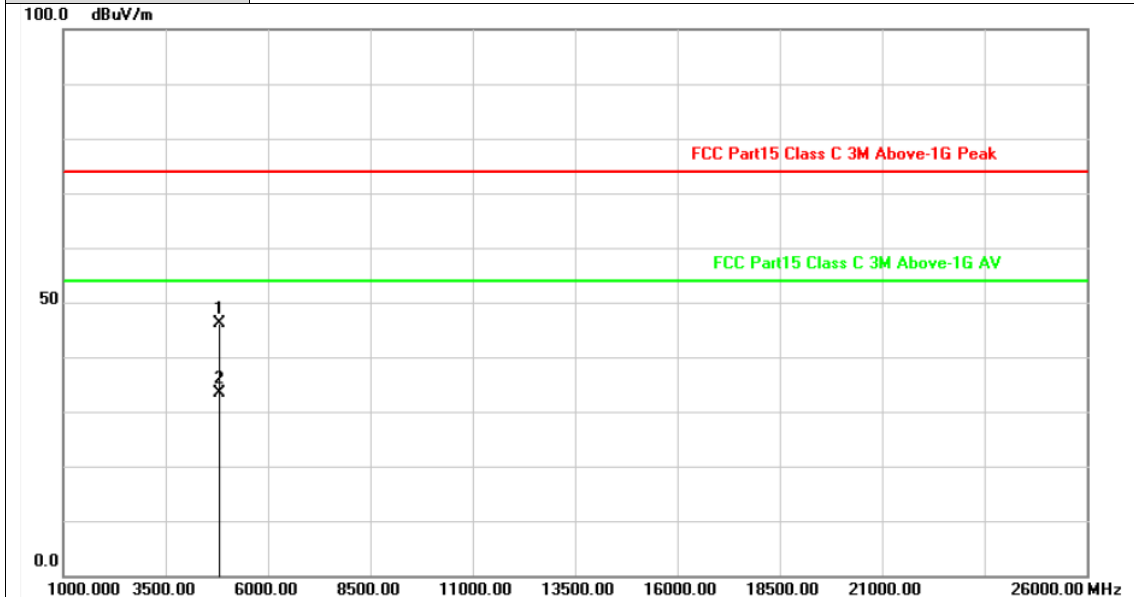

No.	Frequency (MHz)	Factor (dB/m)	Reading (dBuV)	Level (dBuV/m)	Limit (dBuV/m)	Margin (dB)	Detector
1	4803.915	-2.82	49.05	46.23	74.00	-27.77	peak
2	4804.152	-2.82	36.08	33.26	54.00	-20.74	AVG

Remarks:
 1. Factor (dB/m) = Antenna Factor (dB/m)+Cable Factor (dB)-Pre-amplifier Factor
 2. Margin value = Level -Limit value



Ant. Pol.	Horizontal
Test Mode:	TX GFSK Mode 2441MHz
Remark:	No report for the emission which more than 10 dB below the pre-scribed limit.

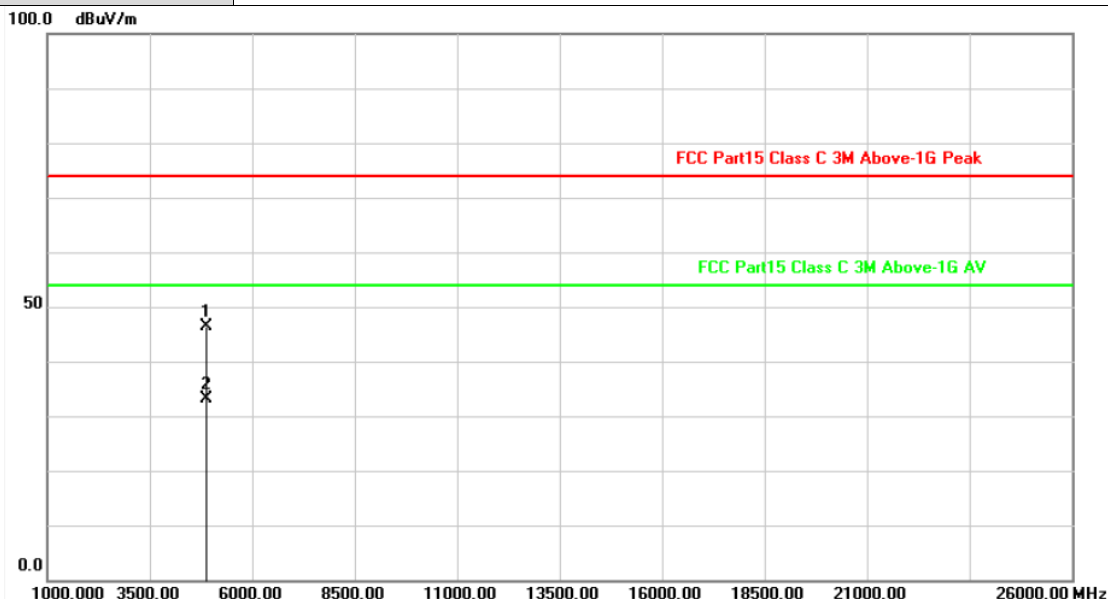

No.	Frequency (MHz)	Factor (dB/m)	Reading (dBuV)	Level (dBuV/m)	Limit (dBuV/m)	Margin (dB)	Detector
1	4881.412	-2.60	48.86	46.26	74.00	-27.74	peak
2	4882.526	-2.59	35.65	33.06	54.00	-20.94	AVG

Remarks:

- 1. Factor (dB/m) = Antenna Factor (dB/m)+Cable Factor (dB)-Pre-amplifier Factor
- 2. Margin value = Level -Limit value



Ant. Pol.	Vertical
Test Mode:	TX GFSK Mode 2441MHz
Remark:	No report for the emission which more than 10 dB below the pre-scribed limit.

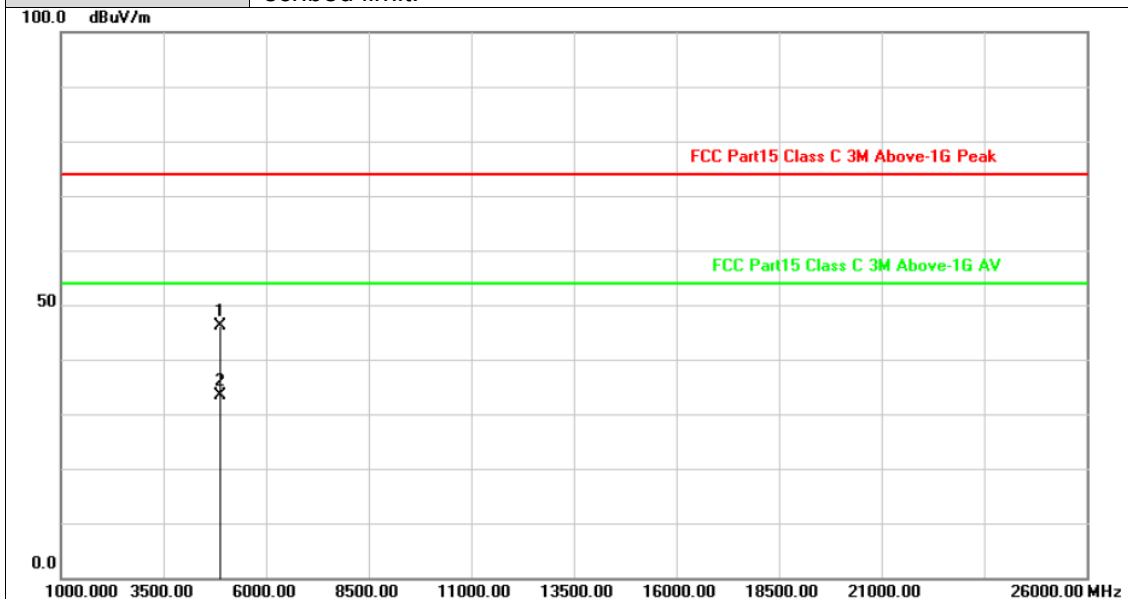

No.	Frequency (MHz)	Factor (dB/m)	Reading (dBuV)	Level (dBuV/m)	Limit (dBuV/m)	Margin (dB)	Detector
1	4882.120	-2.60	48.83	46.23	74.00	-27.77	peak
2	4882.162	-2.60	35.86	33.26	54.00	-20.74	AVG

Remarks:

- Factor (dB/m) = Antenna Factor (dB/m)+Cable Factor (dB)-Pre-amplifier Factor
- Margin value = Level -Limit value



Ant. Pol.	Horizontal
Test Mode:	TX GFSK Mode 2480MHz
Remark:	No report for the emission which more than 10 dB below the pre-scribed limit.

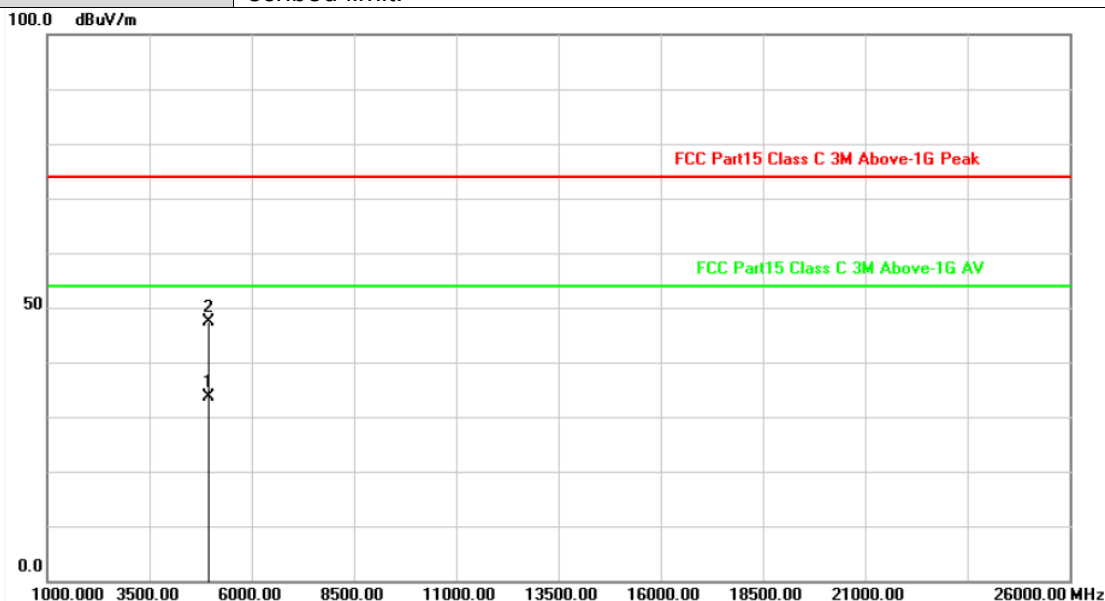

No.	Frequency (MHz)	Factor (dB/m)	Reading (dBuV)	Level (dBuV/m)	Limit (dBuV/m)	Margin (dB)	Detector
1	4959.110	-2.38	36.00	33.62	54.00	-20.38	AVG
2	4959.562	-2.38	49.74	47.36	74.00	-26.64	peak

Remarks:

- Factor (dB/m) = Antenna Factor (dB/m)+Cable Factor (dB)-Pre-amplifier Factor
- Margin value = Level -Limit value



Ant. Pol.	Vertical
Test Mode:	TX GFSK Mode 2480MHz
Remark:	No report for the emission which more than 10 dB below the pre-scribed limit.

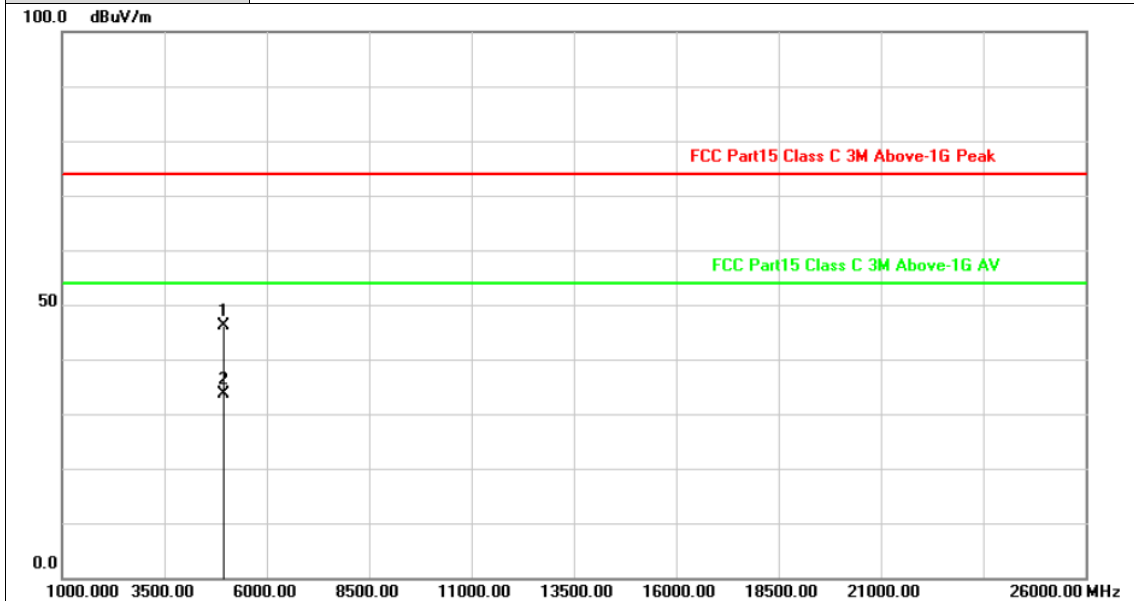

No.	Frequency (MHz)	Factor (dB/m)	Reading (dBuV)	Level (dBuV/m)	Limit (dBuV/m)	Margin (dB)	Detector
1	4959.152	-2.38	48.61	46.23	74.00	-27.77	peak
2	4960.315	-2.38	35.90	33.52	54.00	-20.48	AVG

Remarks:
 1. Factor (dB/m) = Antenna Factor (dB/m)+Cable Factor (dB)-Pre-amplifier Factor
 2. Margin value = Level -Limit value



Ant. Pol.	Horizontal
Test Mode:	TX $\pi/4$ -DQPSK Mode 2402MHz
Remark:	No report for the emission which more than 10 dB below the prescribed limit.

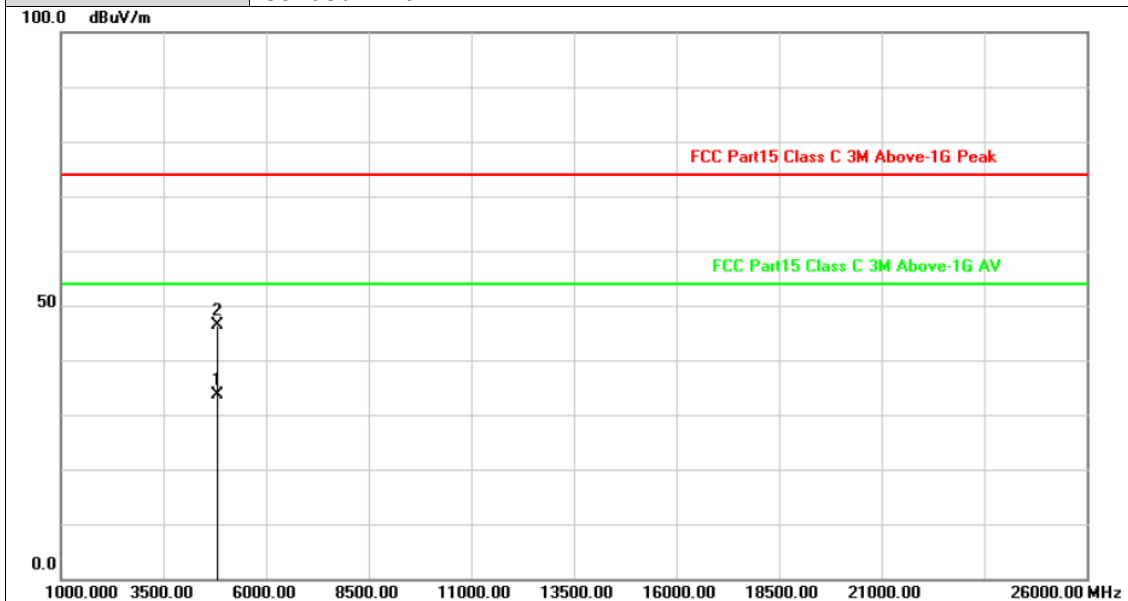

No.	Frequency (MHz)	Factor (dB/m)	Reading (dBuV)	Level (dBuV/m)	Limit (dBuV/m)	Margin (dB)	Detector
1	4803.745	-2.82	36.33	33.51	54.00	-20.49	AVG
2	4803.780	-2.82	49.13	46.31	74.00	-27.69	peak

Remarks:
 1. Factor (dB/m) = Antenna Factor (dB/m)+Cable Factor (dB)-Pre-amplifier Factor
 2. Margin value = Level -Limit value



Ant. Pol.	Vertical
Test Mode:	TX $\pi/4$ -DQPSK Mode 2402MHz
Remark:	No report for the emission which more than 10 dB below the prescribed limit.

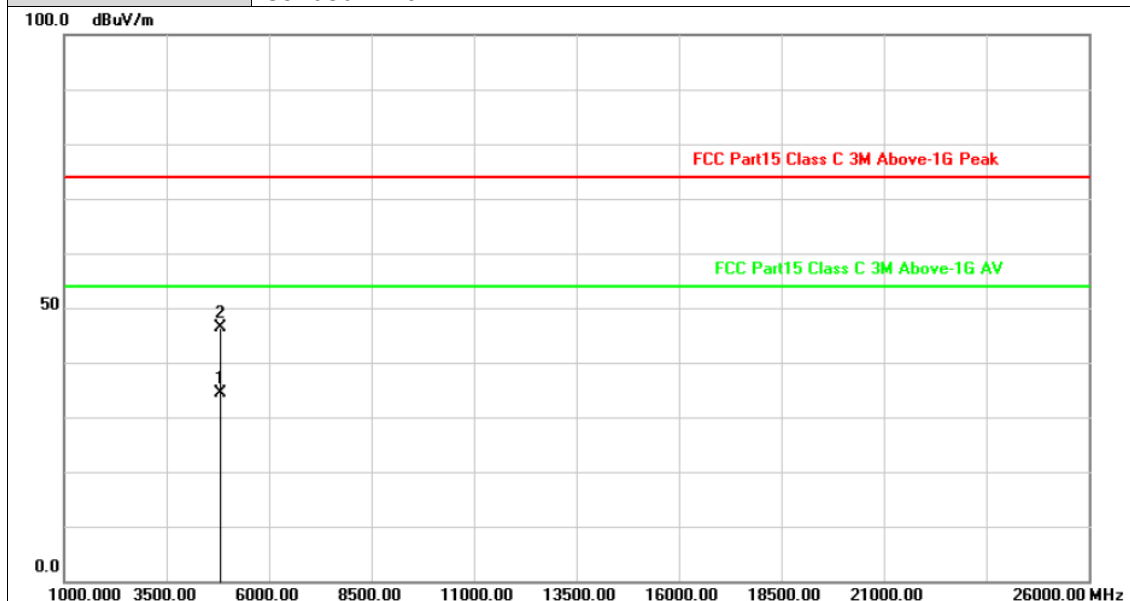

No.	Frequency (MHz)	Factor (dB/m)	Reading (dBuV)	Level (dBuV/m)	Limit (dBuV/m)	Margin (dB)	Detector
1	4804.152	-2.82	37.08	34.26	54.00	-19.74	AVG
2	4804.365	-2.82	49.18	46.36	74.00	-27.64	peak

Remarks:
 1. Factor (dB/m) = Antenna Factor (dB/m)+Cable Factor (dB)-Pre-amplifier Factor
 2. Margin value = Level -Limit value



Ant. Pol.	Horizontal
Test Mode:	TX $\pi/4$ -DQPSK Mode 2441MHz
Remark:	No report for the emission which more than 10 dB below the pre-scribed limit.

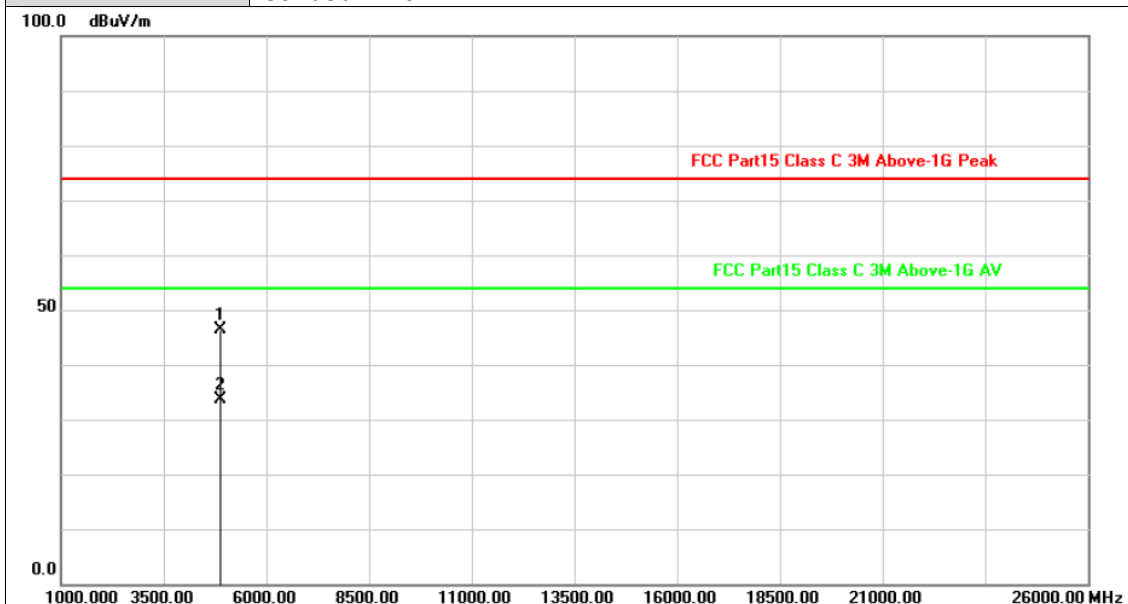

No.	Frequency (MHz)	Factor (dB/m)	Reading (dBuV)	Level (dBuV/m)	Limit (dBuV/m)	Margin (dB)	Detector
1	4881.465	-2.60	48.86	46.26	74.00	-27.74	peak
2	4882.451	-2.60	36.11	33.51	54.00	-20.49	AVG

Remarks:
 1. Factor (dB/m) = Antenna Factor (dB/m)+Cable Factor (dB)-Pre-amplifier Factor
 2. Margin value = Level -Limit value



Ant. Pol.	Vertical
Test Mode:	TX $\pi/4$ -DQPSK Mode 2441MHz
Remark:	No report for the emission which more than 10 dB below the pre-scribed limit.

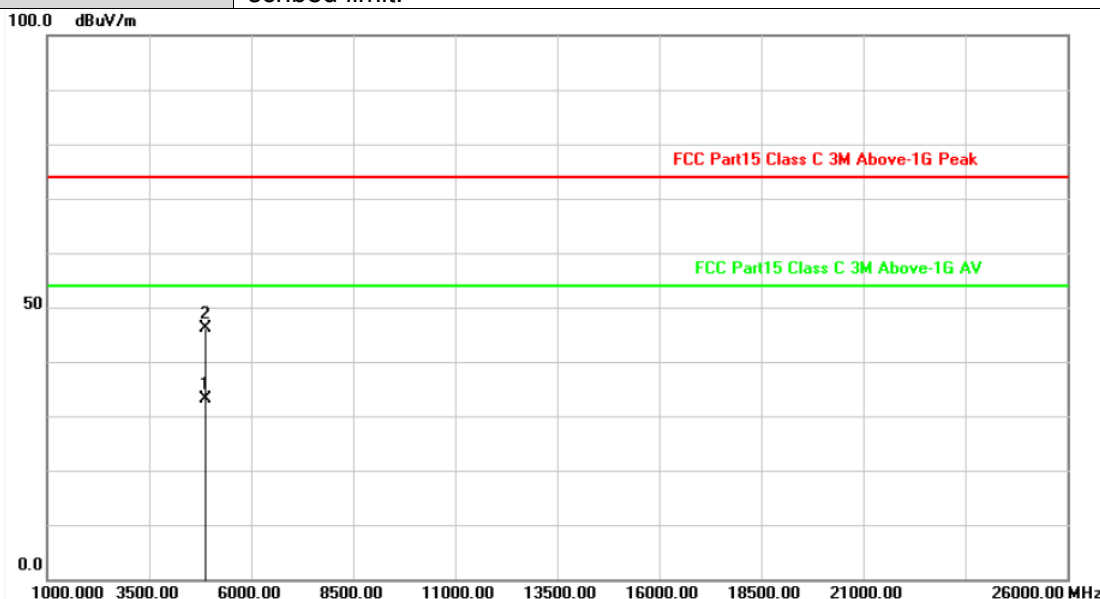

No.	Frequency (MHz)	Factor (dB/m)	Reading (dBuV)	Level (dBuV/m)	Limit (dBuV/m)	Margin (dB)	Detector
1	4882.145	-2.60	35.74	33.14	54.00	-20.86	AVG
2	4882.152	-2.60	48.83	46.23	74.00	-27.77	peak

Remarks:

- Factor (dB/m) = Antenna Factor (dB/m)+Cable Factor (dB)-Pre-amplifier Factor
- Margin value = Level -Limit value



Ant. Pol.	Horizontal
Test Mode:	TX $\pi/4$ -DQPSK Mode 2480MHz
Remark:	No report for the emission which more than 10 dB below the pre-scribed limit.

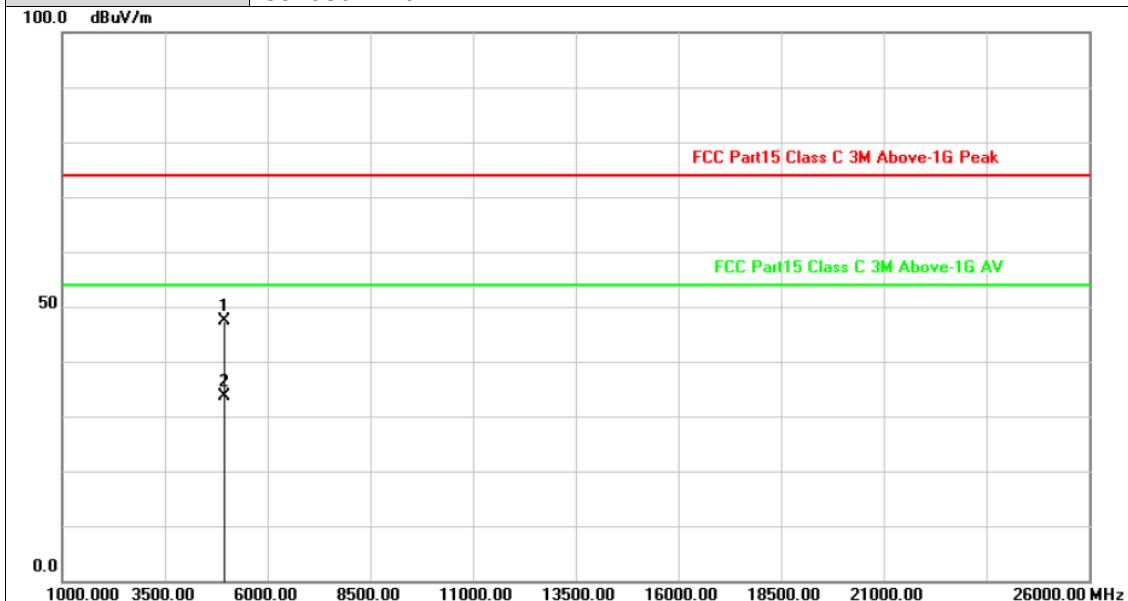

No.	Frequency (MHz)	Factor (dB/m)	Reading (dBuV)	Level (dBuV/m)	Limit (dBuV/m)	Margin (dB)	Detector
1	4960.359	-2.38	49.64	47.26	74.00	-26.74	peak
2	4960.946	-2.38	36.00	33.62	54.00	-20.38	AVG

Remarks:
 1. Factor (dB/m) = Antenna Factor (dB/m)+Cable Factor (dB)-Pre-amplifier Factor
 2. Margin value = Level -Limit value



Ant. Pol.	Vertical
Test Mode:	TX $\pi/4$ -DQPSK Mode 2480MHz
Remark:	No report for the emission which more than 10 dB below the pre-scribed limit.

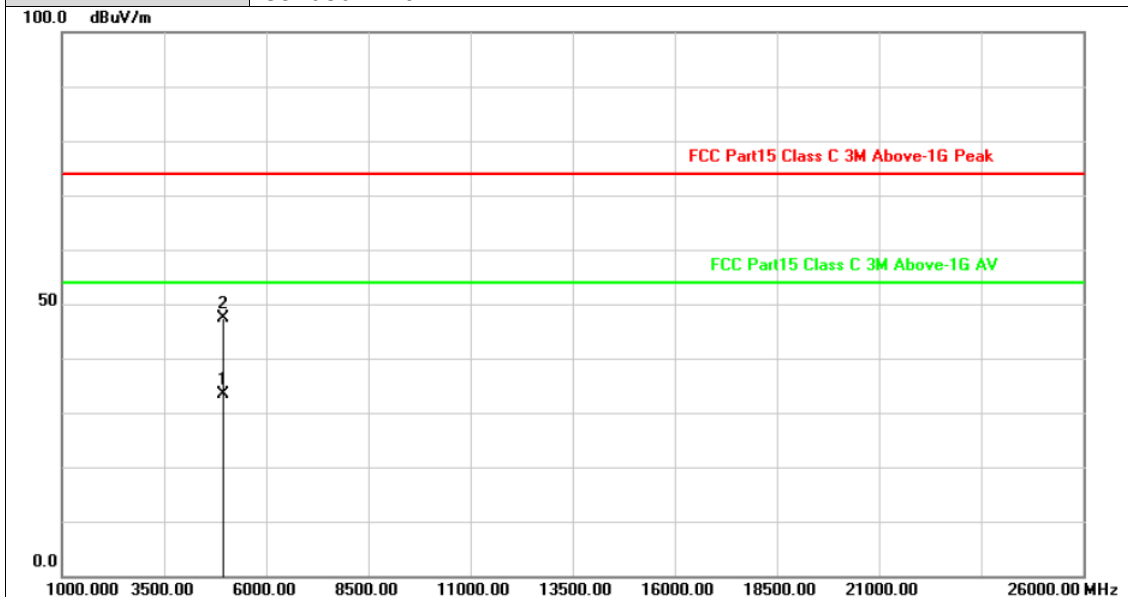

No.	Frequency (MHz)	Factor (dB/m)	Reading (dBuV)	Level (dBuV/m)	Limit (dBuV/m)	Margin (dB)	Detector
1	4959.956	-2.38	35.64	33.26	54.00	-20.74	AVG
2	4960.152	-2.38	49.64	47.26	74.00	-26.74	peak

Remarks:
 1. Factor (dB/m) = Antenna Factor (dB/m)+Cable Factor (dB)-Pre-amplifier Factor
 2. Margin value = Level -Limit value



Ant. Pol.	Horizontal
Test Mode:	TX 8-DPSK Mode 2402MHz
Remark:	No report for the emission which more than 10 dB below the prescribed limit.

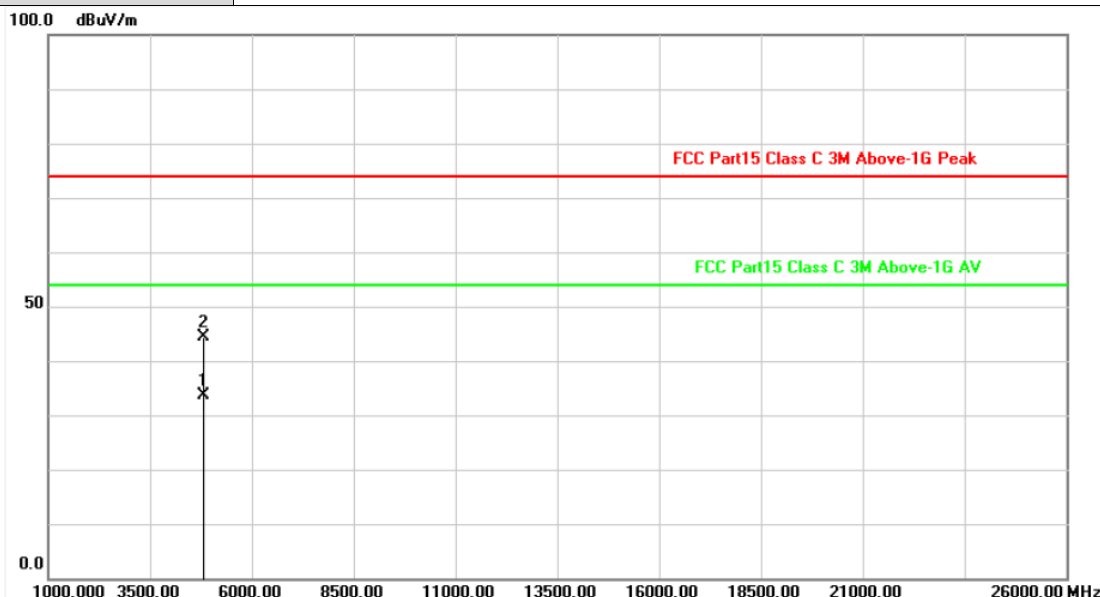

No.	Frequency (MHz)	Factor (dB/m)	Reading (dBuV)	Level (dBuV/m)	Limit (dBuV/m)	Margin (dB)	Detector
1	4804.120	-2.82	36.44	33.62	54.00	-20.38	AVG
2	4804.152	-2.82	47.08	44.26	74.00	-29.74	peak

Remarks:

- Factor (dB/m) = Antenna Factor (dB/m)+Cable Factor (dB)-Pre-amplifier Factor
- Margin value = Level -Limit value



Ant. Pol.	Vertical
Test Mode:	TX 8-DPSK Mode 2402MHz
Remark:	No report for the emission which more than 10 dB below the pre-scribed limit.

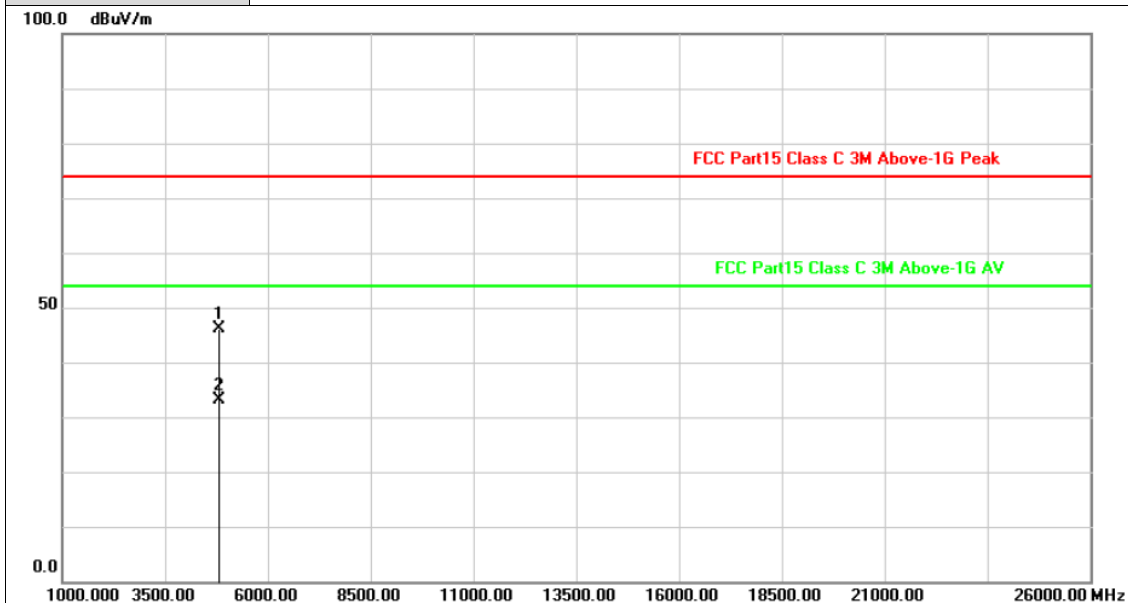

No.	Frequency (MHz)	Factor (dB/m)	Reading (dBuV)	Level (dBuV/m)	Limit (dBuV/m)	Margin (dB)	Detector
1	4802.103	-2.83	49.06	46.23	74.00	-27.77	peak
2	4802.230	-2.83	35.98	33.15	54.00	-20.85	AVG

Remarks:
 1. Factor (dB/m) = Antenna Factor (dB/m)+Cable Factor (dB)-Pre-amplifier Factor
 2. Margin value = Level -Limit value



Ant. Pol.	Horizontal
Test Mode:	TX 8-DPSK Mode 2441MHz
Remark:	No report for the emission which more than 10 dB below the prescribed limit.

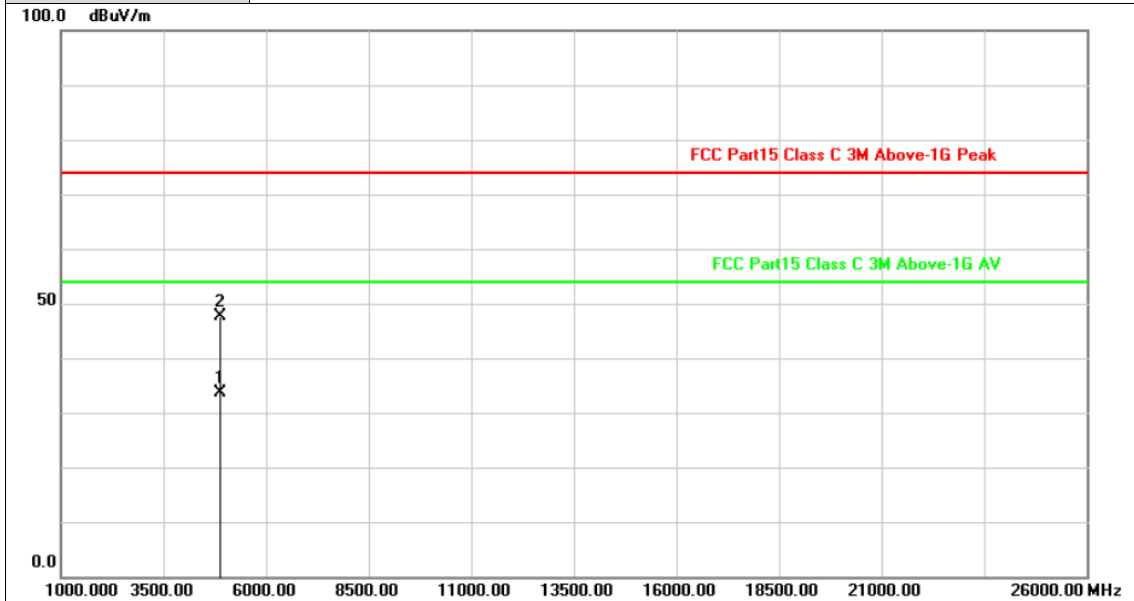

No.	Frequency (MHz)	Factor (dB/m)	Reading (dBuV)	Level (dBuV/m)	Limit (dBuV/m)	Margin (dB)	Detector
1	4881.859	-2.60	36.22	33.62	54.00	-20.38	AVG
2	4882.451	-2.60	50.22	47.62	74.00	-26.38	peak

Remarks:
 1. Factor (dB/m) = Antenna Factor (dB/m)+Cable Factor (dB)-Pre-amplifier Factor
 2. Margin value = Level -Limit value



Ant. Pol.	Vertical
Test Mode:	TX 8-DPSK Mode 2441MHz
Remark:	No report for the emission which more than 10 dB below the pre-scribed limit.

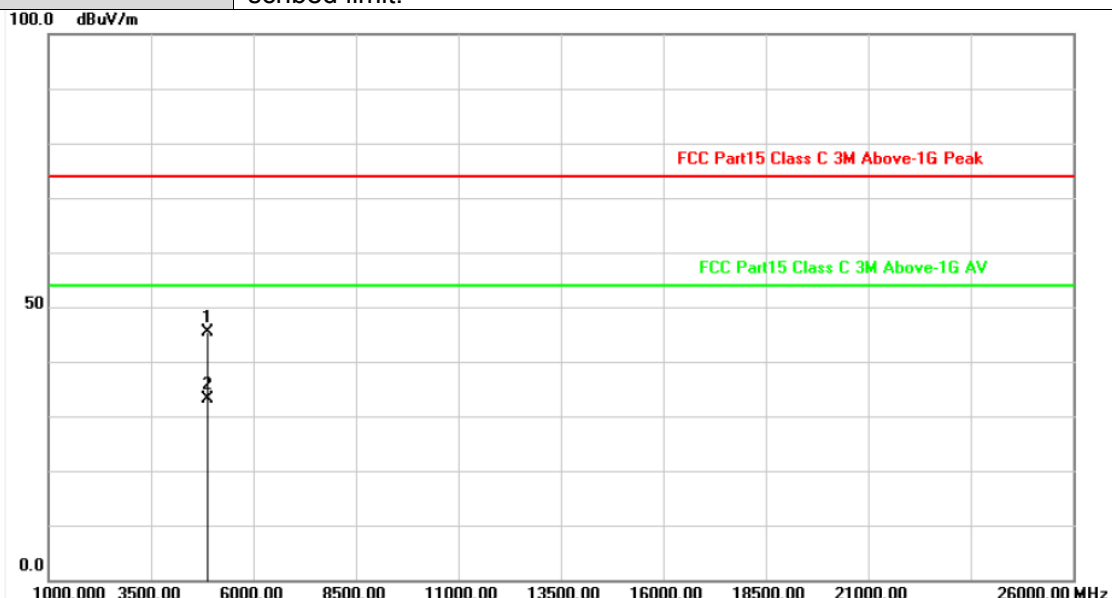

No.	Frequency (MHz)	Factor (dB/m)	Reading (dBuV)	Level (dBuV/m)	Limit (dBuV/m)	Margin (dB)	Detector
1	4882.022	-2.60	47.86	45.26	74.00	-28.74	peak
2	4882.041	-2.60	35.81	33.21	54.00	-20.79	AVG

Remarks:

- Factor (dB/m) = Antenna Factor (dB/m)+Cable Factor (dB)-Pre-amplifier Factor
- Margin value = Level -Limit value



Ant. Pol.	Horizontal
Test Mode:	TX 8-DPSK Mode 2480MHz
Remark:	No report for the emission which more than 10 dB below the prescribed limit.

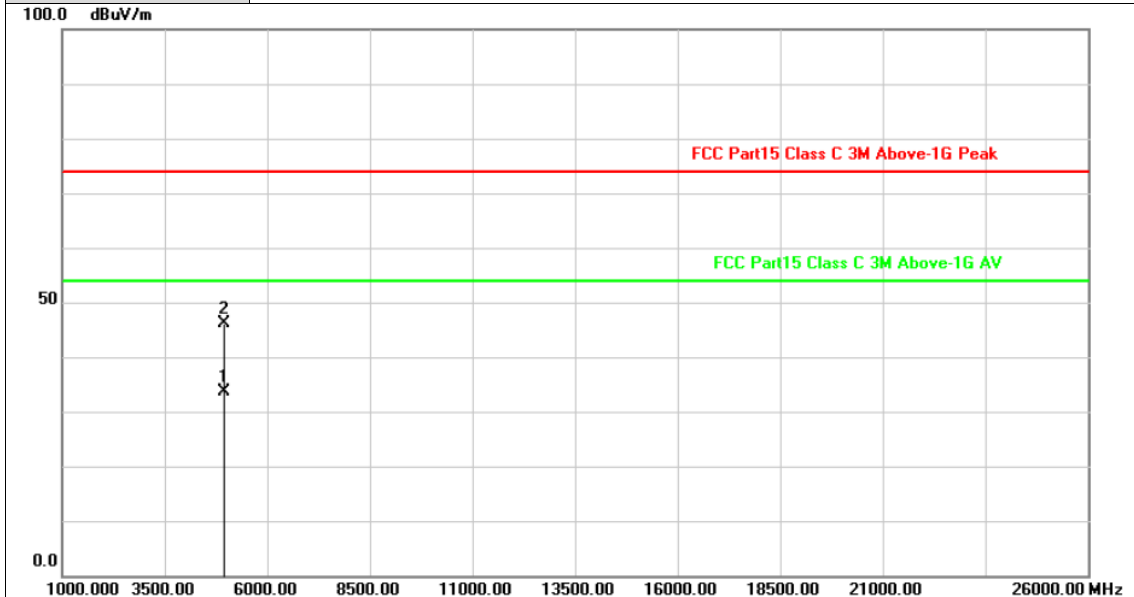

No.	Frequency (MHz)	Factor (dB/m)	Reading (dBuV)	Level (dBuV/m)	Limit (dBuV/m)	Margin (dB)	Detector
1	4959.451	-2.38	36.00	33.62	54.00	-20.38	AVG
2	4960.352	-2.38	48.59	46.21	74.00	-27.79	peak

Remarks:
 1. Factor (dB/m) = Antenna Factor (dB/m)+Cable Factor (dB)-Pre-amplifier Factor
 2. Margin value = Level -Limit value



Ant. Pol.	Vertical
Test Mode:	TX 8-DPSK Mode 2480MHz
Remark:	No report for the emission which more than 10 dB below the pre-scribed limit.

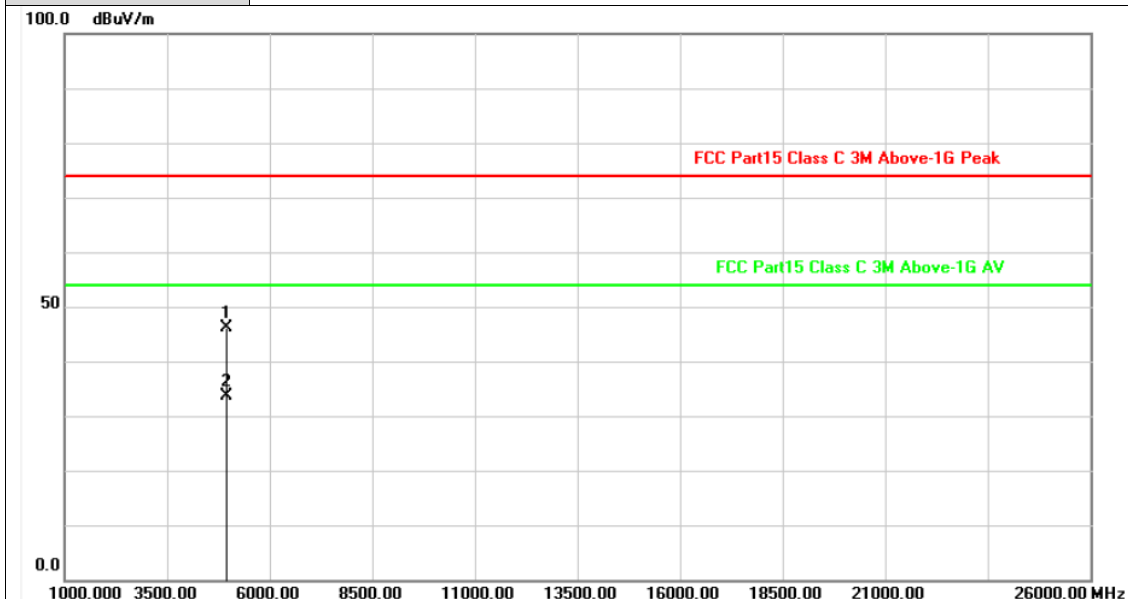

No.	Frequency (MHz)	Factor (dB/m)	Reading (dBuV)	Level (dBuV/m)	Limit (dBuV/m)	Margin (dB)	Detector
1	4959.903	-2.38	48.61	46.23	74.00	-27.77	peak
2	4960.012	-2.38	36.03	33.65	54.00	-20.35	AVG

Remarks:
 1. Factor (dB/m) = Antenna Factor (dB/m)+Cable Factor (dB)-Pre-amplifier Factor
 2. Margin value = Level -Limit value

3.3. Band Edge Emissions (Radiated)

Limit

FCC CFR Title 47 Part 15 Subpart C Section 15.247 (d):

Restricted Frequency Band (MHz)	(dBuV/m)(at 3m)	
	Peak	Average
2310 ~ 2390	74	54
2483.5 ~ 2500	74	54

Test Configuration

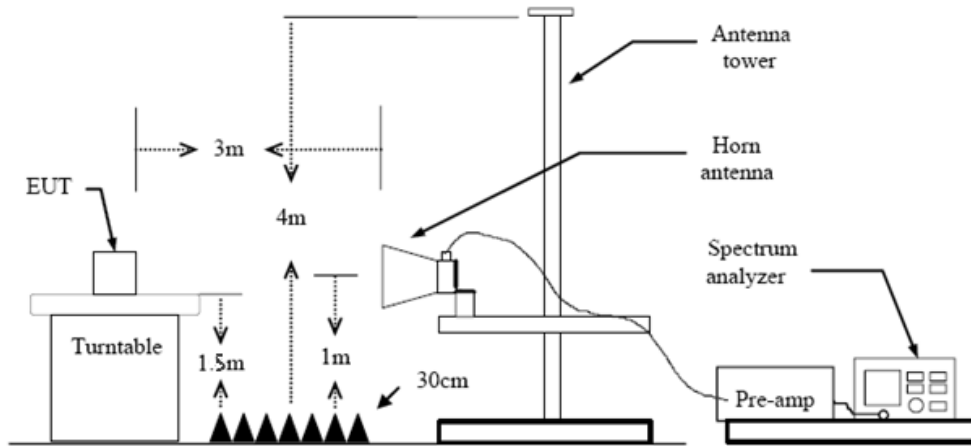

Test Procedure

1. The EUT was setup and tested according to ANSI C63.10:2013 requirements.
2. The EUT is placed on a turn table which is 1.5 meter above ground. The turn table is rotated 360 degrees to determine the position of the maximum emission level.
3. The EUT was positioned such that the distance from antenna to the EUT was 3 meters.
4. The antenna is scanned from 1 meter to 4 meters to find out the maximum emission level. This is repeated for both horizontal and vertical polarization of the antenna. In order to find the maximum emission, all of the interface cables were manipulated according to ANSI C63.10:2013 on radiated measurement.
5. The receiver set as follow:
 RBW=1MHz, VBW=3MHz Peak detector for Peak value.
 RBW=1MHz, VBW see note 1 with Peak Detector for Average Value.

Note 1: For measurements above 1 GHz the resolution bandwidth is set to 1 MHz, then the video bandwidth is set to 3 MHz for peak measurements and 1 MHz resolution bandwidth with 1/T video bandwidth with peak detector for average measurements. For the Duty Cycle please refer to clause 3.9 Duty Cycle.

Test Mode

Please refer to the clause 2.4.



Test Results

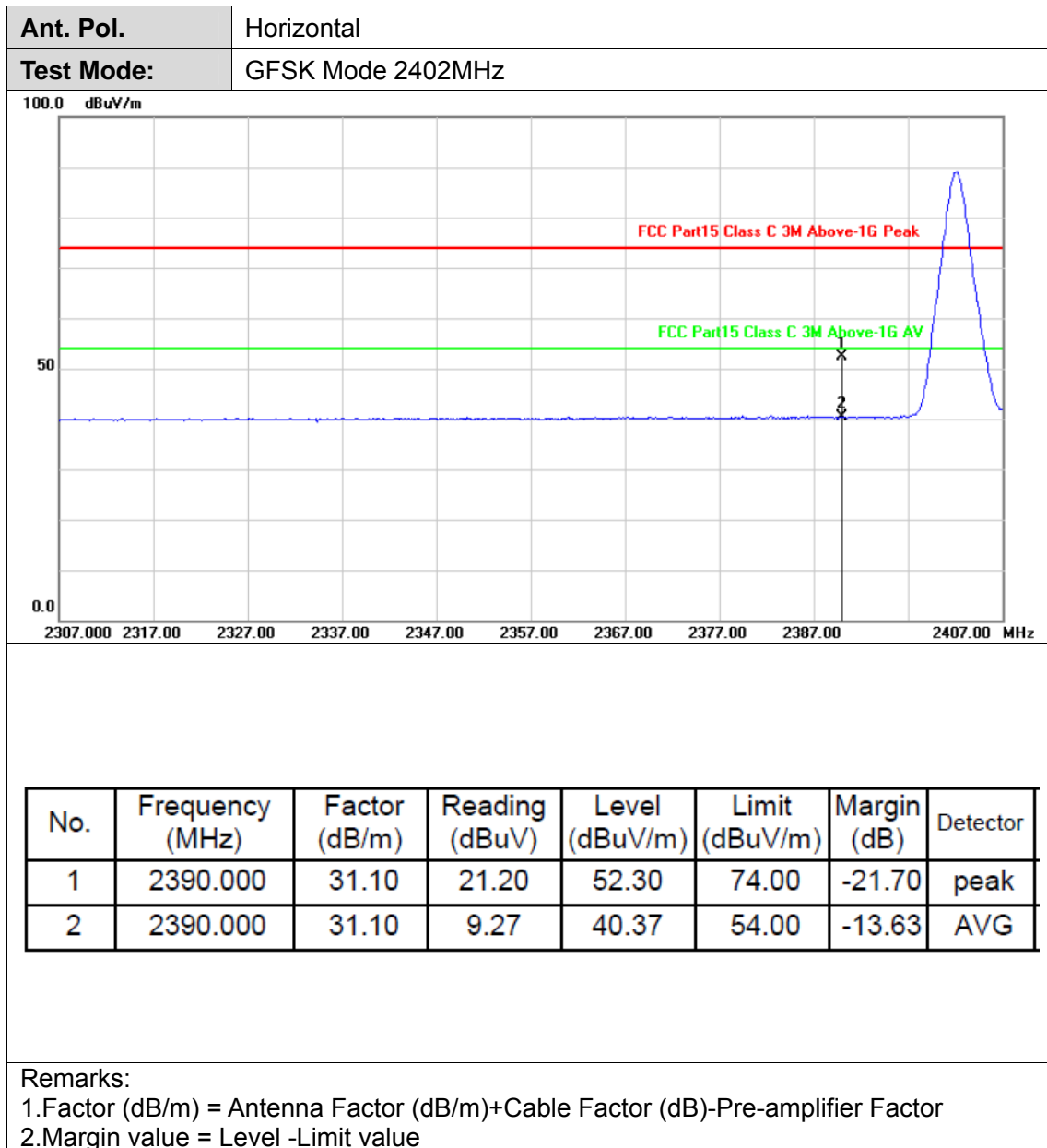



Ant. Pol.	Vertical
Test Mode:	GFSK Mode 2402MHz

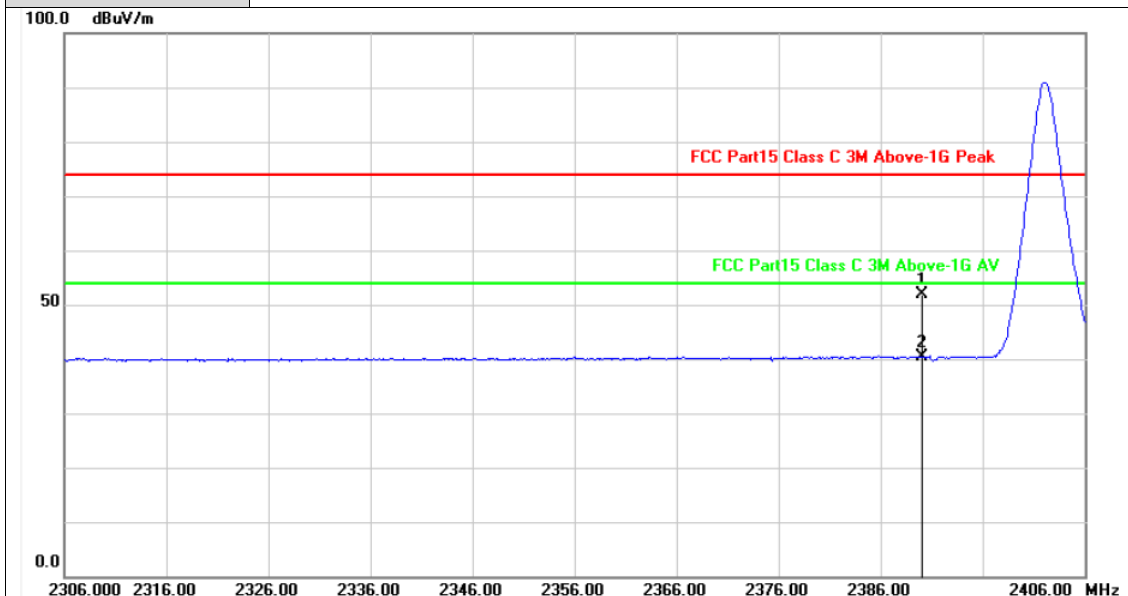

No.	Frequency (MHz)	Factor (dB/m)	Reading (dBuV)	Level (dBuV/m)	Limit (dBuV/m)	Margin (dB)	Detector
1	2390.000	31.10	20.79	51.89	74.00	-22.11	peak
2	2390.000	31.10	9.26	40.36	54.00	-13.64	AVG

Remarks:

- 1. Factor (dB/m) = Antenna Factor (dB/m)+Cable Factor (dB)-Pre-amplifier Factor
- 2. Margin value = Level -Limit value



Ant. Pol.	Horizontal
Test Mode:	GFSK Mode 2480 MHz

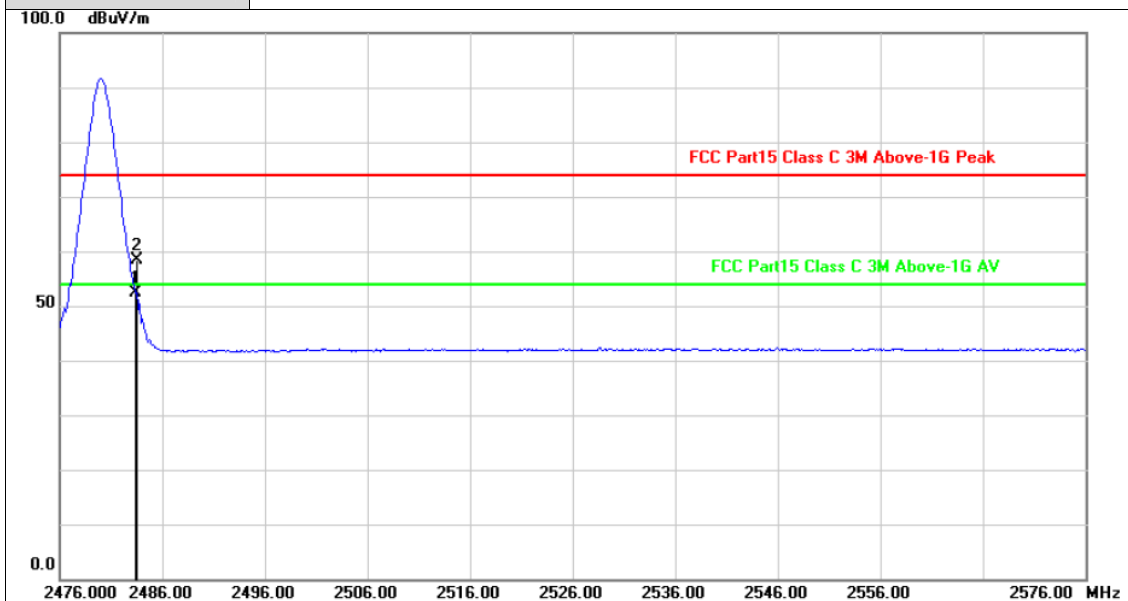

No.	Frequency (MHz)	Factor (dB/m)	Reading (dBuV)	Level (dBuV/m)	Limit (dBuV/m)	Margin (dB)	Detector
1	2483.500	31.50	20.87	52.37	54.00	-1.63	AVG
2	2483.500	31.50	26.82	58.32	74.00	-15.68	peak

Remarks:

- 1.Factor (dB/m) = Antenna Factor (dB/m)+Cable Factor (dB)-Pre-amplifier Factor
- 2.Margin value = Level -Limit value



Ant. Pol.	Vertical
Test Mode:	GFSK Mode 2480 MHz

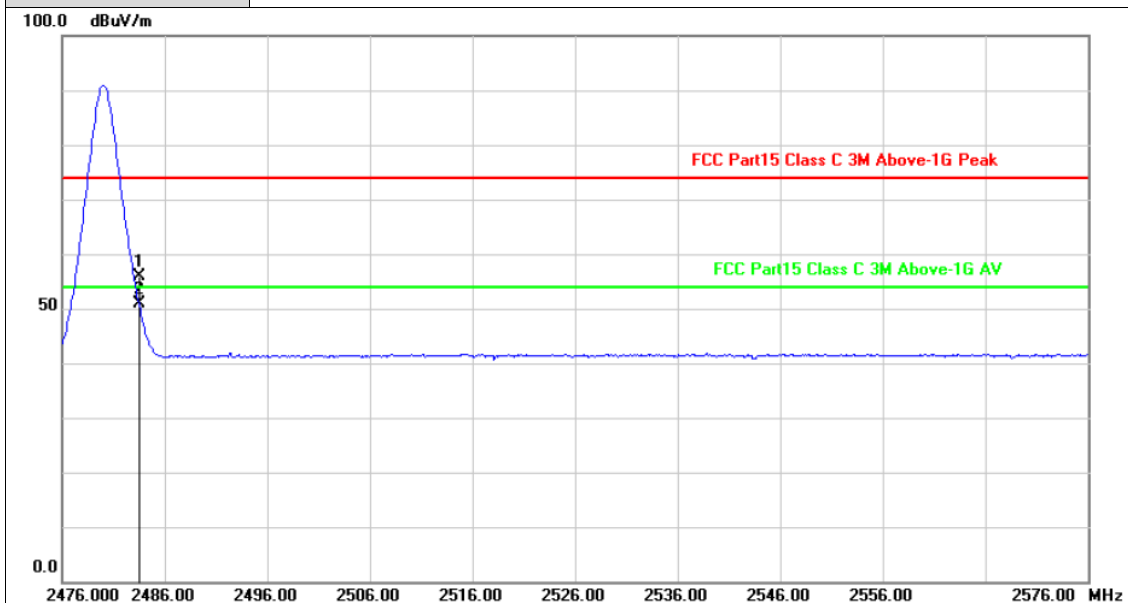

No.	Frequency (MHz)	Factor (dB/m)	Reading (dBuV)	Level (dBuV/m)	Limit (dBuV/m)	Margin (dB)	Detector
1	2483.500	31.50	24.28	55.78	74.00	-18.22	peak
2	2483.500	31.50	19.42	50.92	54.00	-3.08	AVG

Remarks:

- Factor (dB/m) = Antenna Factor (dB/m)+Cable Factor (dB)-Pre-amplifier Factor
- Margin value = Level -Limit value



Ant. Pol.	Horizontal
Test Mode:	$\pi/4$ -DQPSK Mode 2402MHz

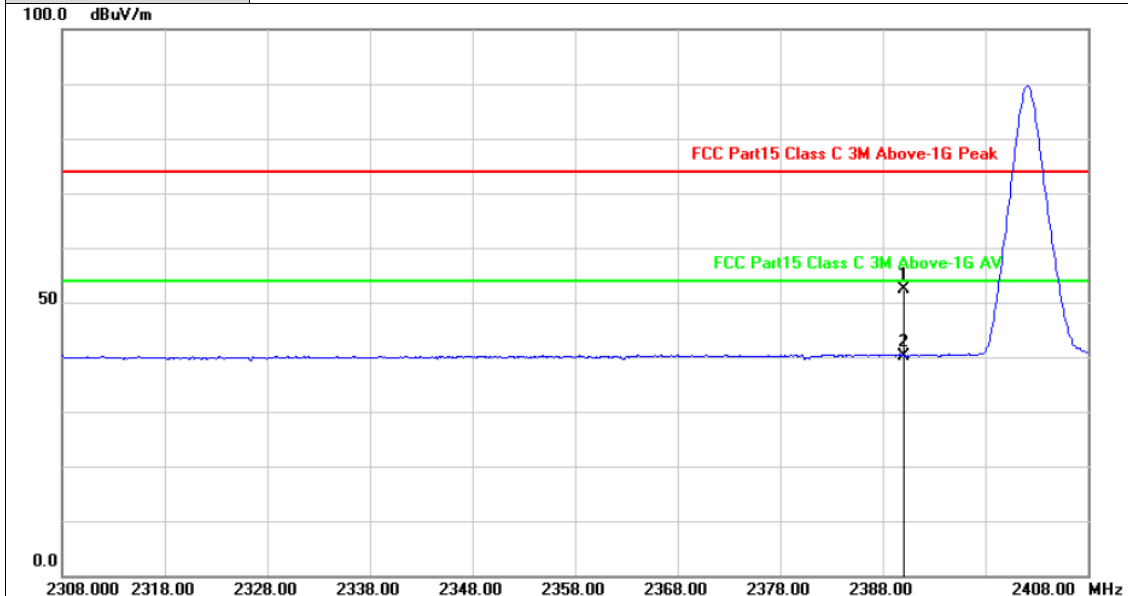

No.	Frequency (MHz)	Factor (dB/m)	Reading (dBuV)	Level (dBuV/m)	Limit (dBuV/m)	Margin (dB)	Detector
1	2390.000	31.10	21.26	52.36	74.00	-21.64	peak
2	2390.000	31.10	9.10	40.20	54.00	-13.80	AVG

Remarks:

- Factor (dB/m) = Antenna Factor (dB/m)+Cable Factor (dB)-Pre-amplifier Factor
- Margin value = Level -Limit value



Ant. Pol.	Vertical
Test Mode:	$\pi/4$ -DQPSK Mode 2402MHz

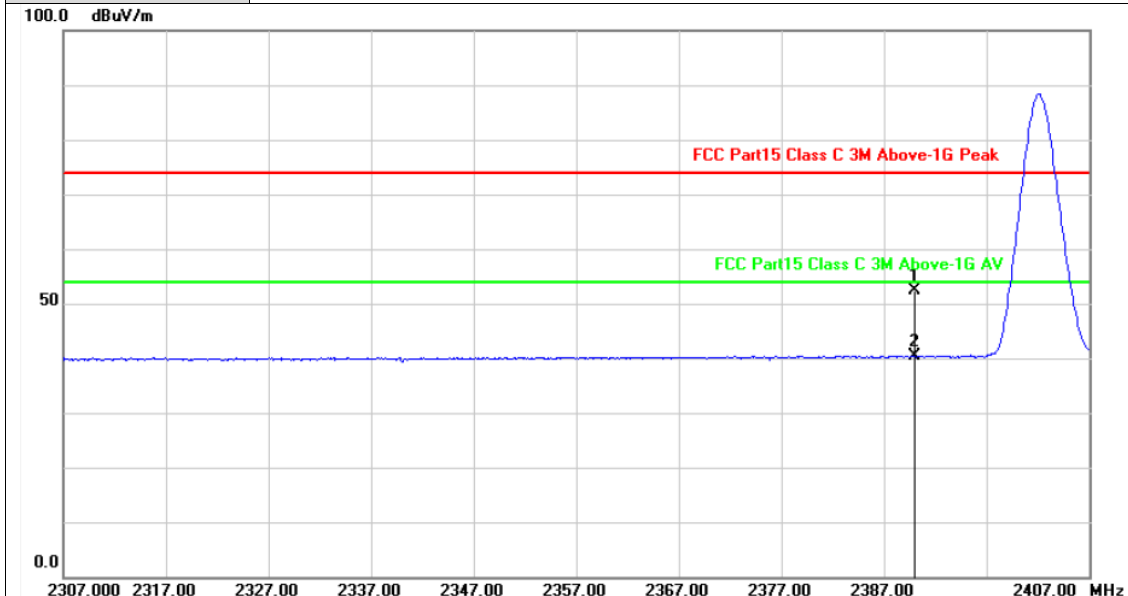

No.	Frequency (MHz)	Factor (dB/m)	Reading (dBuV)	Level (dBuV/m)	Limit (dBuV/m)	Margin (dB)	Detector
1	2390.000	31.10	21.23	52.33	74.00	-21.67	peak
2	2390.000	31.10	9.39	40.49	54.00	-13.51	AVG

Remarks:

- Factor (dB/m) = Antenna Factor (dB/m)+Cable Factor (dB)-Pre-amplifier Factor
- Margin value = Level -Limit value



Ant. Pol.	Horizontal
Test Mode:	$\pi/4$ -DQPSK Mode 2480MHz

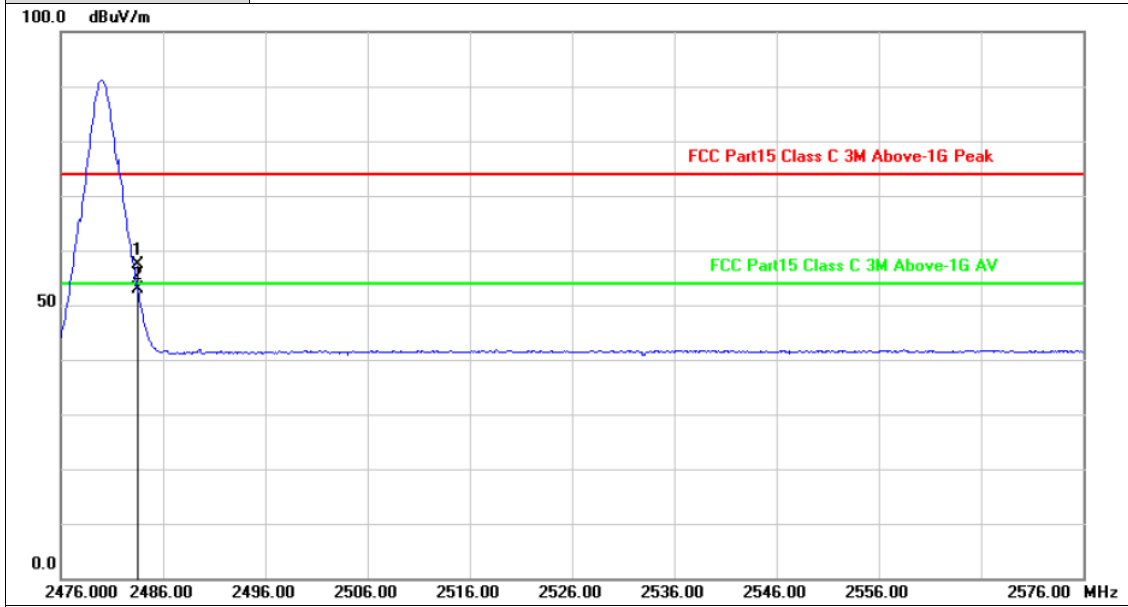

No.	Frequency (MHz)	Factor (dB/m)	Reading (dBuV)	Level (dBuV/m)	Limit (dBuV/m)	Margin (dB)	Detector
1	2483.500	31.50	25.94	57.44	74.00	-16.56	peak
2	2483.500	31.50	21.37	52.87	54.00	-1.13	AVG

Remarks:

- 1.Factor (dB/m) = Antenna Factor (dB/m)+Cable Factor (dB)-Pre-amplifier Factor
- 2.Margin value = Level -Limit value



Ant. Pol.	Vertical
Test Mode:	$\pi/4$ -DQPSK Mode 2480MHz

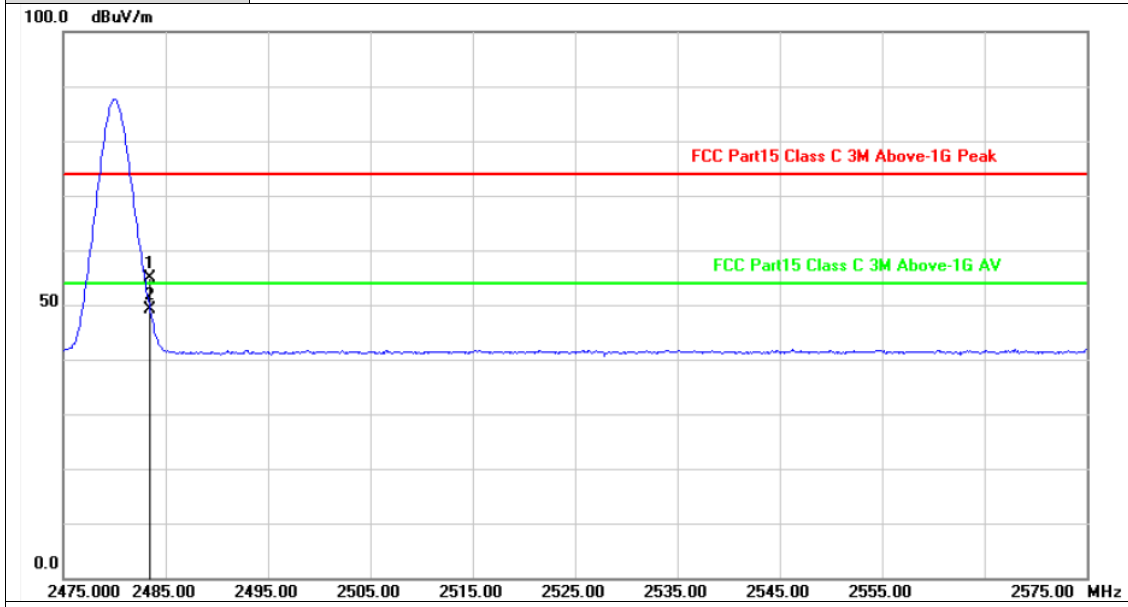

No.	Frequency (MHz)	Factor (dB/m)	Reading (dBuV)	Level (dBuV/m)	Limit (dBuV/m)	Margin (dB)	Detector
1	2483.500	31.50	23.27	54.77	74.00	-19.23	peak
2	2483.500	31.50	17.58	49.08	54.00	-4.92	AVG

Remarks:

- Factor (dB/m) = Antenna Factor (dB/m)+Cable Factor (dB)-Pre-amplifier Factor
- Margin value = Level -Limit value



Ant. Pol.	Horizontal
Test Mode:	8-DPSK Mode 2402MHz

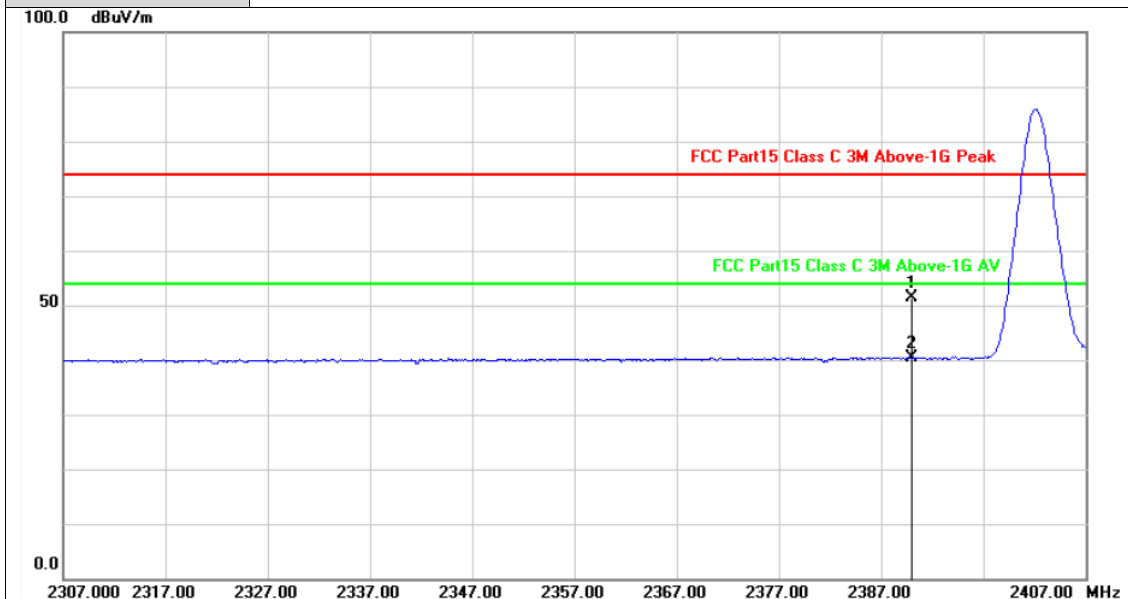

No.	Frequency (MHz)	Factor (dB/m)	Reading (dBuV)	Level (dBuV/m)	Limit (dBuV/m)	Margin (dB)	Detector
1	2390.000	31.10	20.37	51.47	74.00	-22.53	peak
2	2390.000	31.10	9.28	40.38	54.00	-13.62	AVG

Remarks:

- Factor (dB/m) = Antenna Factor (dB/m)+Cable Factor (dB)-Pre-amplifier Factor
- Margin value = Level -Limit value



Ant. Pol.	Vertical
Test Mode:	8-DPSK Mode 2402MHz

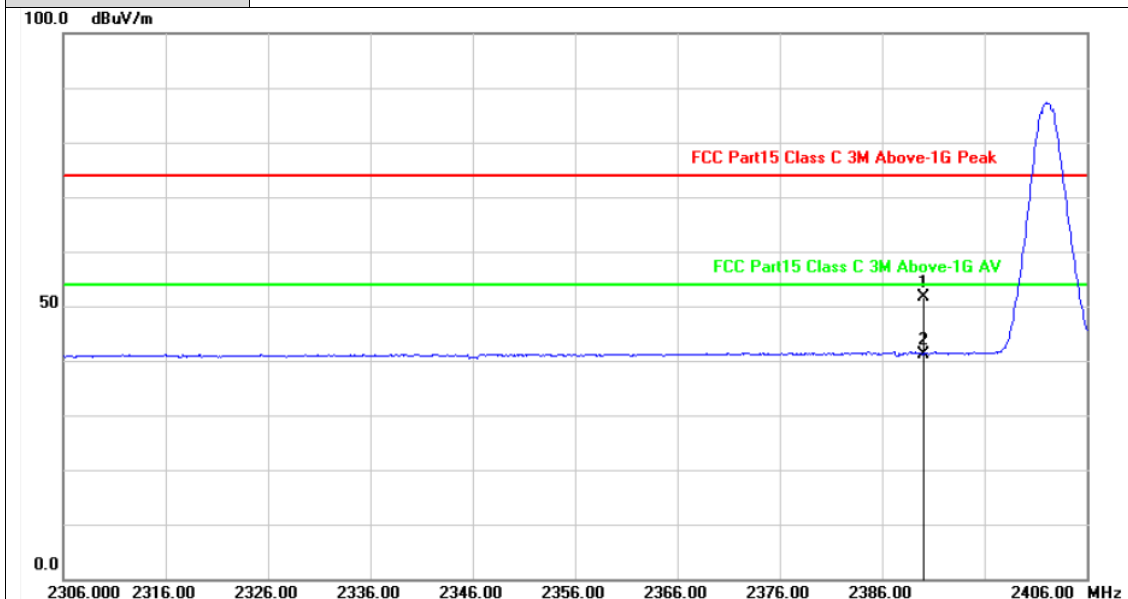

No.	Frequency (MHz)	Factor (dB/m)	Reading (dBuV)	Level (dBuV/m)	Limit (dBuV/m)	Margin (dB)	Detector
1	2390.000	31.10	20.57	51.67	74.00	-22.33	peak
2	2390.000	31.10	10.12	41.22	54.00	-12.78	AVG

Remarks:

- Factor (dB/m) = Antenna Factor (dB/m)+Cable Factor (dB)-Pre-amplifier Factor
- Margin value = Level -Limit value



Ant. Pol.	Horizontal
Test Mode:	8-DPSK Mode 2480MHz

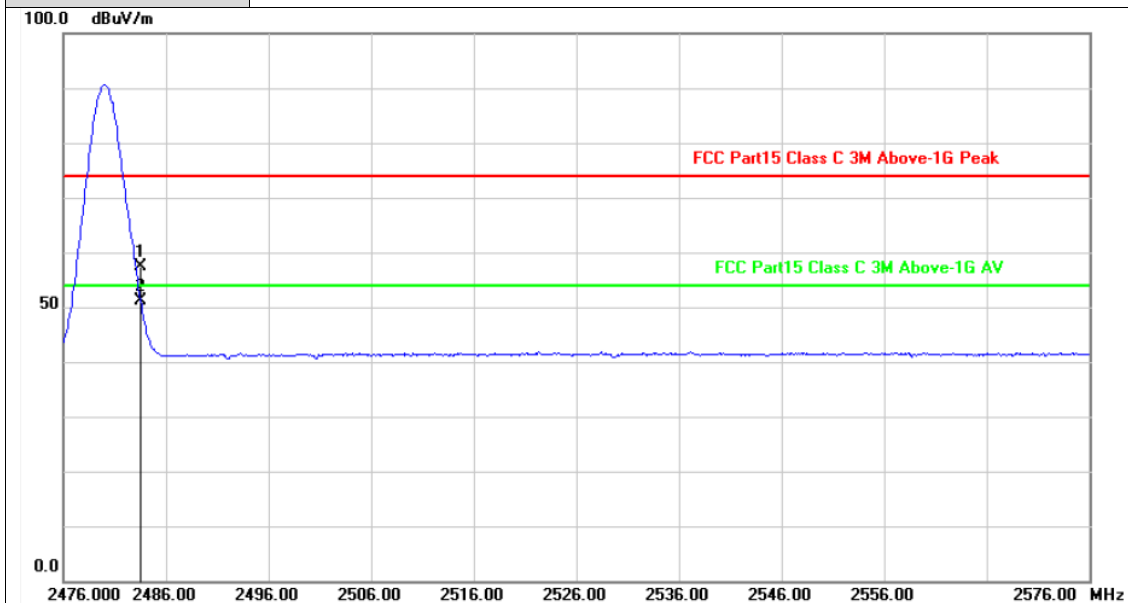

No.	Frequency (MHz)	Factor (dB/m)	Reading (dBuV)	Level (dBuV/m)	Limit (dBuV/m)	Margin (dB)	Detector
1	2483.500	31.50	25.93	57.43	74.00	-16.57	peak
2	2483.500	31.50	19.75	51.25	54.00	-2.75	AVG

Remarks:

- Factor (dB/m) = Antenna Factor (dB/m)+Cable Factor (dB)-Pre-amplifier Factor
- Margin value = Level -Limit value



Ant. Pol.	Vertical
Test Mode:	8-DPSK Mode 2480MHz

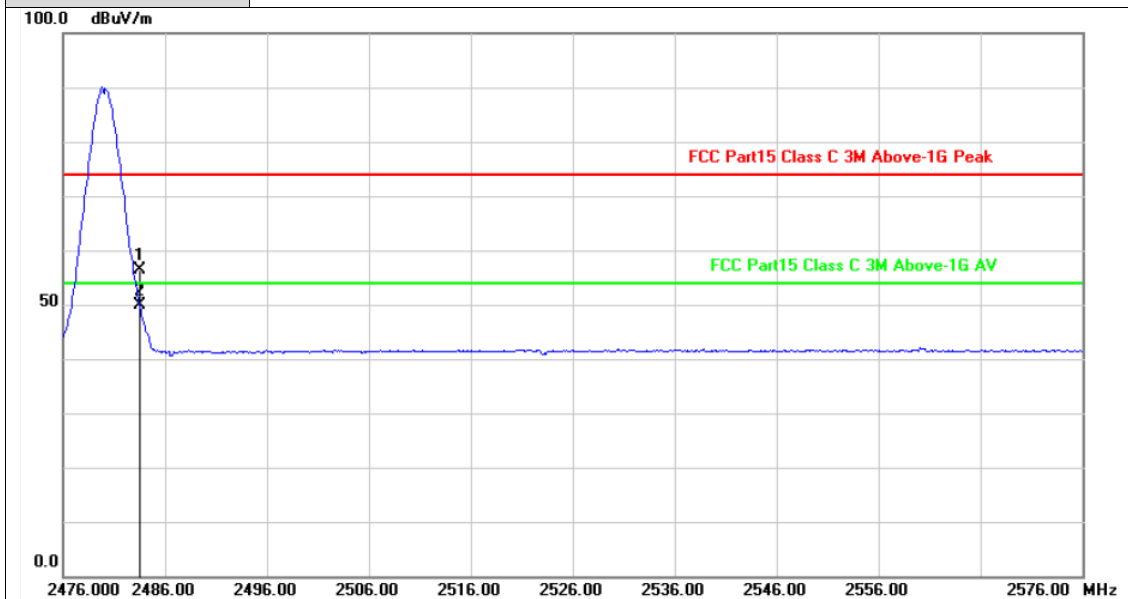

No.	Frequency (MHz)	Factor (dB/m)	Reading (dBuV)	Level (dBuV/m)	Limit (dBuV/m)	Margin (dB)	Detector
1	2483.500	31.50	24.97	56.47	74.00	-17.53	peak
2	2483.500	31.50	18.26	49.76	54.00	-4.24	AVG

Remarks:

- Factor (dB/m) = Antenna Factor (dB/m)+Cable Factor (dB)-Pre-amplifier Factor
- Margin value = Level -Limit value



3.4. Band edge and Spurious Emissions (Conducted)

Limit

FCC CFR Title 47 Part 15 Subpart C Section 15.247 (d): In any 100 kHz bandwidth outside the frequency band in which the spread spectrum intentional radiator is operating, the radio frequency power that is produced by the intentional radiator shall be at least 20 dB below that in the 100 kHz bandwidth within the band that contains the highest level of the desired power, based on either an RF conducted or a radiated measurement.

Test Configuration

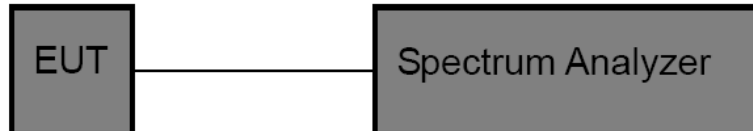

Test Procedure

1. The transmitter output was connected to the spectrum analyzer through an attenuator, the path loss was compensated to the results for each measurement.
2. Set to the maximum power setting and enable the EUT transmit continuously
3. Use the following spectrum analyzer settings:
RBW = 100 kHz, VBW ≥ RBW, scan up through 10th harmonic.
Sweep = auto, Detector function = peak, Trace = max hold
4. Measure and record the results in the test report.

Test Mode

Please refer to the clause 2.4.

Test Results

(1) Band edge Conducted Test

Test Mode	Frequency[MHz]	Ref Level[dBm]	Result[dBm]	Limit[dBm]	Verdict
GFSK	2402	8.53	-58.24	<=-11.47	PASS
	2480	9.82	-57.24	<=-10.18	PASS
	Hop_2402	4.88	-58.72	-15.12	PASS
	Hop_2480	5.27	-59.09	-14.73	PASS
π/4-DQPSK	2402	3.10	-53.59	<=-16.9	PASS
	2480	5.55	-59.08	<=-14.45	PASS
	Hop_2402	0.49	-59.16	-19.51	PASS
	Hop_2480	5.29	-59.29	-14.71	PASS
8-DPSK	2402	3.53	-52.6	<=-16.47	PASS
	2480	3.92	-58.62	<=-16.08	PASS
	Hop_2402	-2.39	-59.44	-22.39	PASS
	Hop_2480	4.94	-59.24	-15.06	PASS



DH5_Low_2402

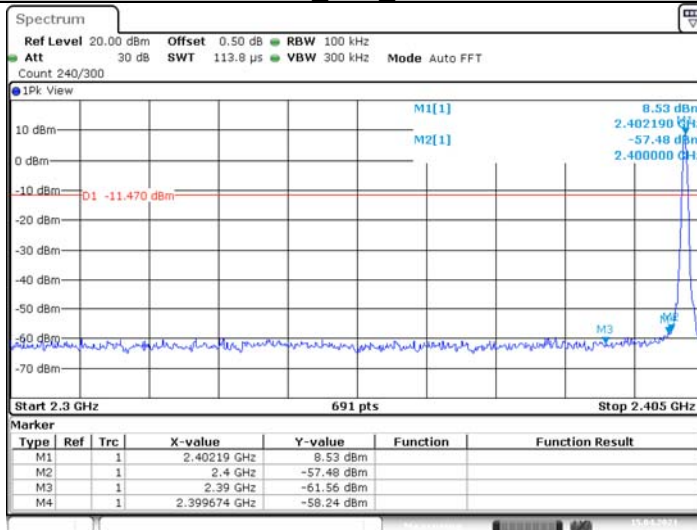

Date: 15.APR.2021 11:39:03

DH5_High_2480

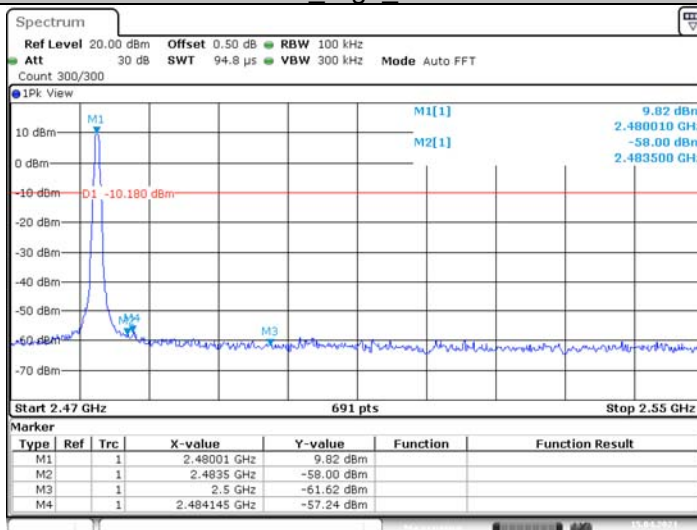

Date: 15.APR.2021 11:44:01

DH5_Low_Hop_2402

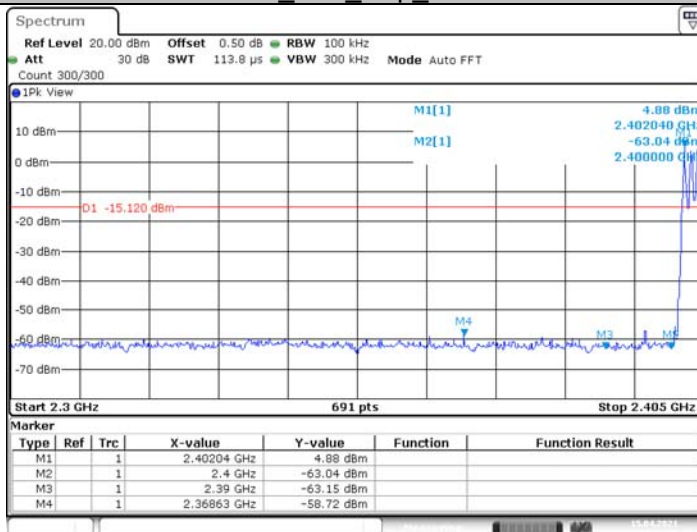

Date: 15.APR.2021 13:40:00

DH5_High_Hop_2480

CTC Laboratories, Inc.

1-2/F., Building 2, Jiaquan Building, Guanlan High-Tech Park, Shenzhen, Guangdong, China

Tel.: (86)755-27521059

Fax: (86)755-27521011

Http://www.sz-ctc.org.cn



For anti-fake verification, please visit the official website of Certification and Accreditation Administration of the People's Republic of China : yz.cnca.cn

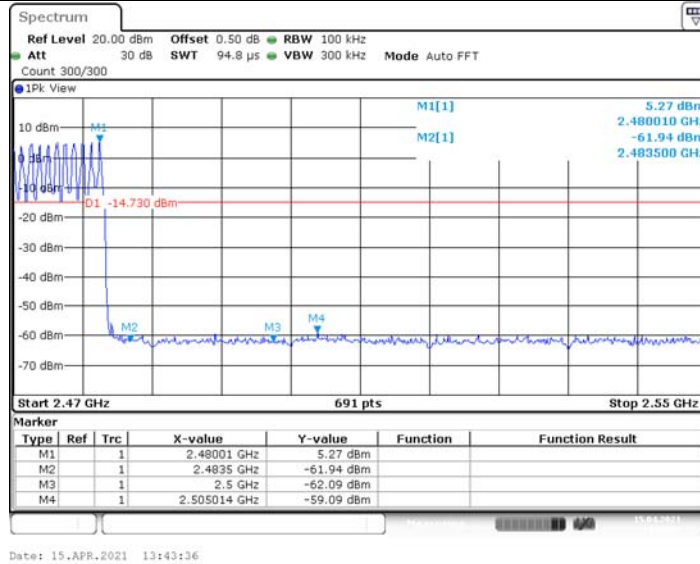

2DH5 Low 2402

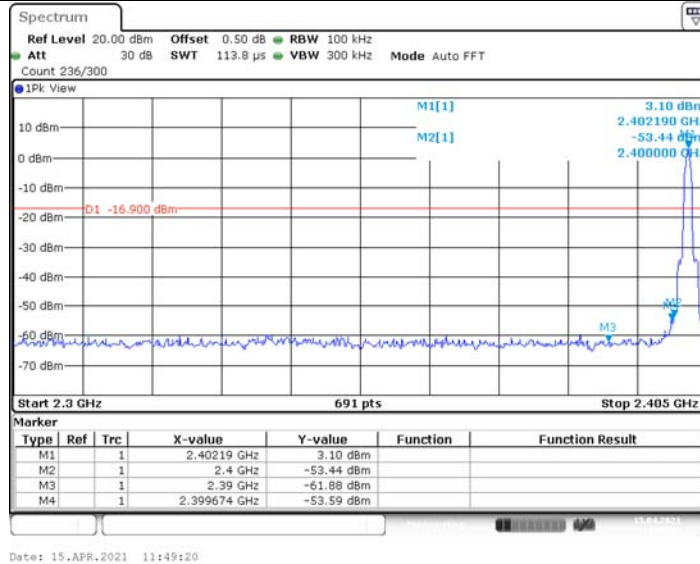

2DH5 High 2480

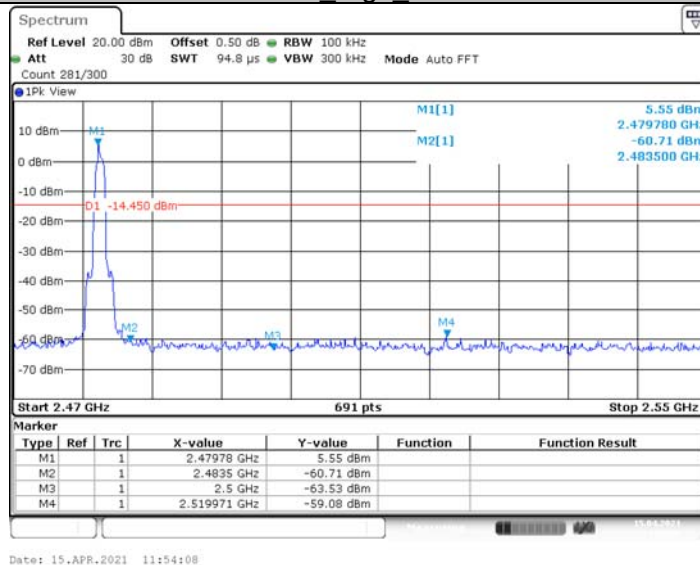

2DH5 Low Hop 2402

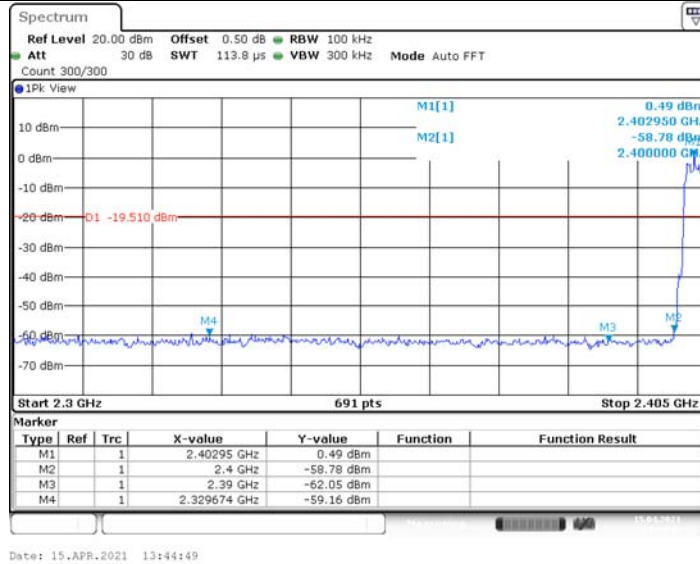

2DH5 High Hop 2480

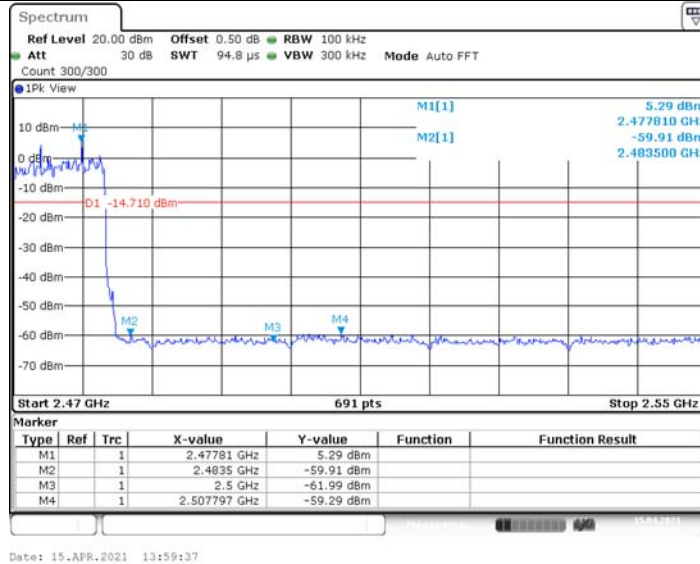

3DH5 Low 2402

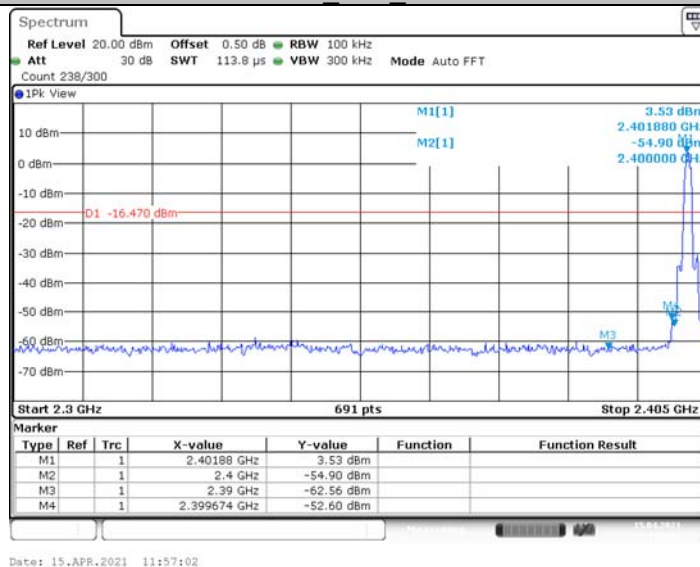

3DH5 High 2480

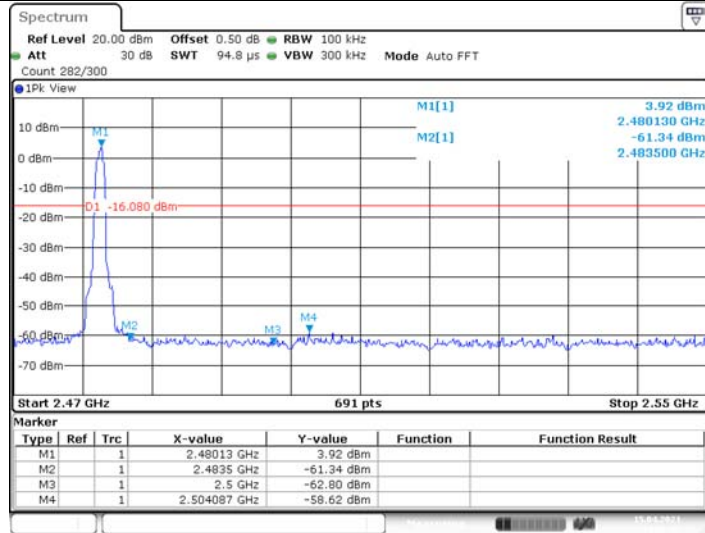

Date: 15.APR.2021 13:37:32

3DH5 Low Hop 2402

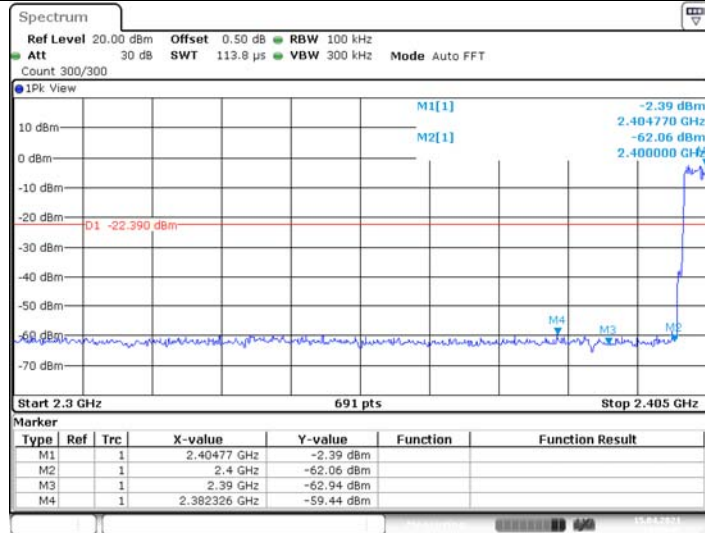

Date: 15.APR.2021 14:00:49

3DH5 High Hop 2480

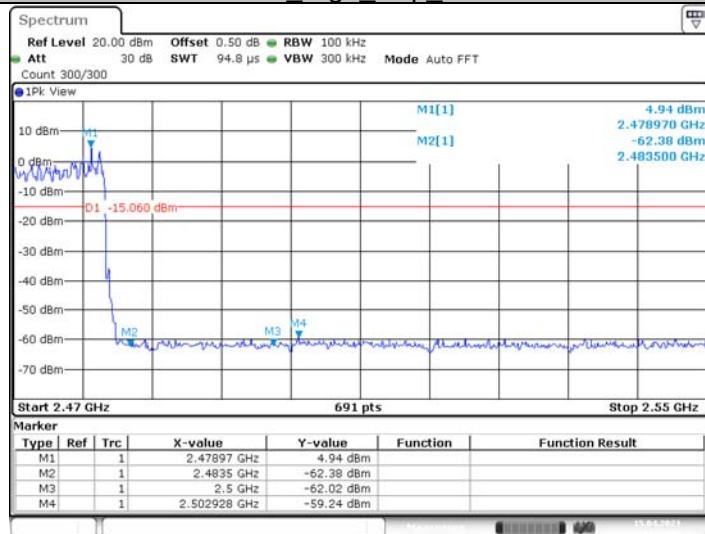

Date: 15.APR.2021 14:12:06



(2) Conducted Spurious Emissions Test

Test Mode	Frequency[MHz]	Freq Range [MHz]	Ref Level [dBm]	Result [dBm]	Limit [dBm]	Verdict
GFSK	2402	Reference	8.64	8.64	---	PASS
		30~1000	30~1000	-71.26	<=-11.36	PASS
		1000~26500	1000~26500	-47.36	<=-11.36	PASS
	2441	Reference	9.46	9.46	---	PASS
		30~1000	30~1000	-71.01	<=-10.54	PASS
		1000~26500	1000~26500	-47.36	<=-10.54	PASS
	2480	Reference	10.08	10.08	---	PASS
		30~1000	30~1000	-71.18	<=-9.92	PASS
		1000~26500	1000~26500	-46.57	<=-9.92	PASS
π / /4-DQPSK	2402	Reference	4.06	4.06	---	PASS
		30~1000	30~1000	-70.58	<=-15.94	PASS
		1000~26500	1000~26500	-40.8	<=-15.94	PASS
	2441	Reference	6.13	6.13	---	PASS
		30~1000	30~1000	-70.99	<=-13.87	PASS
		1000~26500	1000~26500	-46.53	<=-13.87	PASS
	2480	Reference	6.36	6.36	---	PASS
		30~1000	30~1000	-70.27	<=-13.64	PASS
		1000~26500	1000~26500	-46.02	<=-13.64	PASS
8-DPSK	2402	Reference	4.13	4.13	---	PASS
		30~1000	30~1000	-71.13	<=-15.87	PASS
		1000~26500	1000~26500	-35.91	<=-15.87	PASS
	2441	Reference	5.74	5.74	---	PASS
		30~1000	30~1000	-70.51	<=-14.26	PASS
		1000~26500	1000~26500	-46.45	<=-14.26	PASS
	2480	Reference	5.10	5.10	---	PASS
		30~1000	30~1000	-71.47	<=-14.9	PASS
		1000~26500	1000~26500	-46.72	<=-14.9	PASS



GFSK_2402_0~Reference



Date: 15.APR.2021 11:40:04

GFSK_2402_30~1000

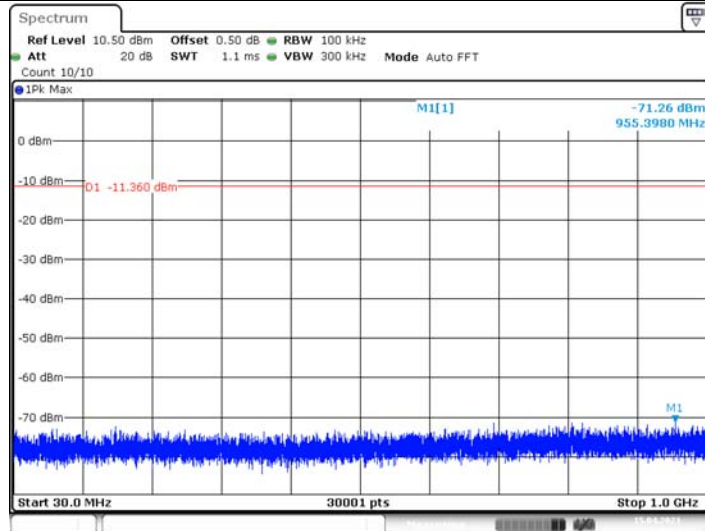

Date: 15.APR.2021 11:40:14

GFSK_2402_1000~26500

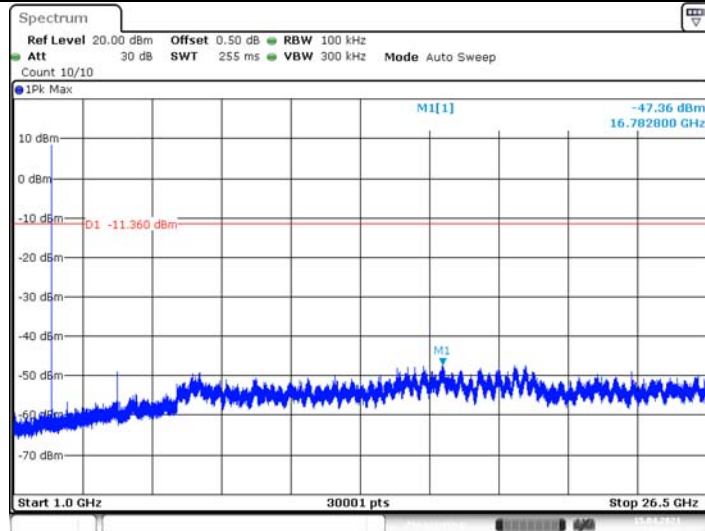

Date: 15.APR.2021 11:40:41

GFSK_2441_0~Reference

CTC Laboratories, Inc.

1-2/F., Building 2, Jiaquan Building, Guanlan High-Tech Park, Shenzhen, Guangdong, China

Tel.: (86)755-27521059

Fax: (86)755-27521011 Http://www.sz-ctc.org.cn



For anti-fake verification, please visit the official website of Certification and Accreditation Administration of the People's Republic of China : yz.cnca.cn

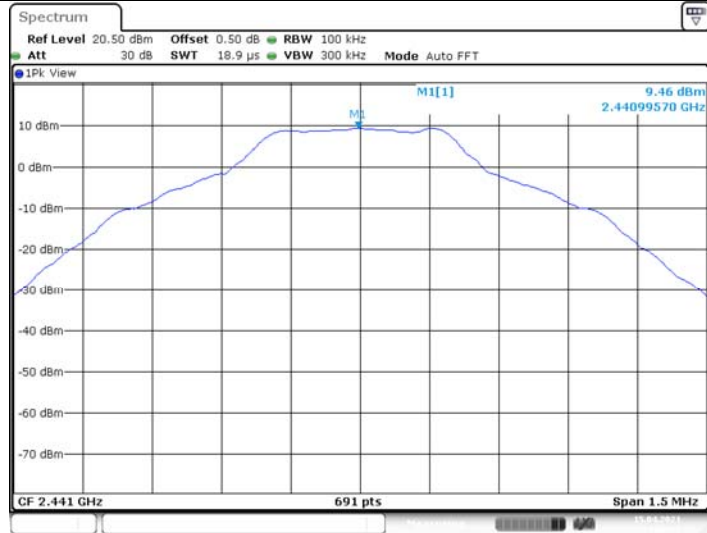

GFSK 2441 30~1000

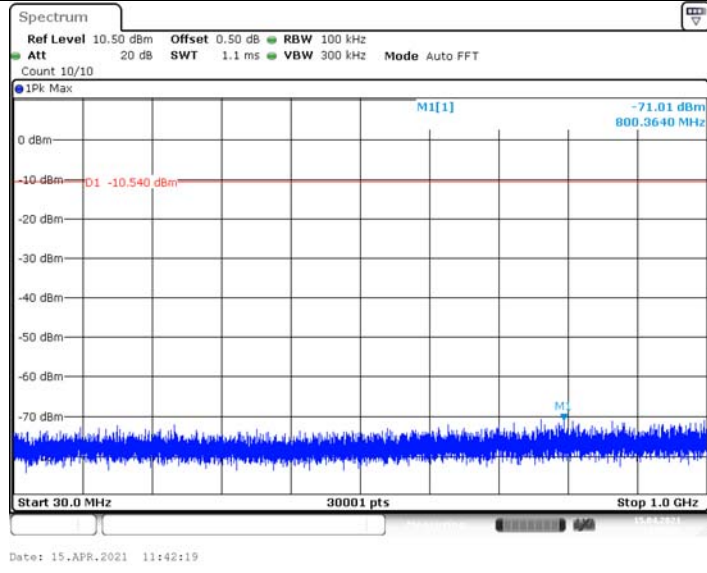

GFSK 2441 1000~26500

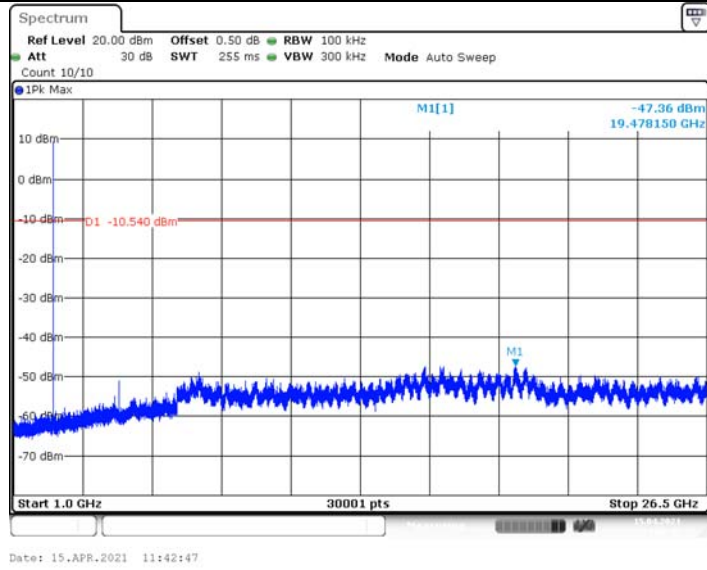

GFSK_2480_0~Reference

CTC Laboratories, Inc.

1-2/F., Building 2, Jiaquan Building, Guanlan High-Tech Park, Shenzhen, Guangdong, China
Tel.: (86)755-27521059

Fax: (86)755-27521011 Http://www.sz-ctc.org.cn
For anti-fake verification, please visit the official website of Certification and Accreditation Administration of the People's Republic of China : yz.cnca.cn





GFSK 2480 30~1000

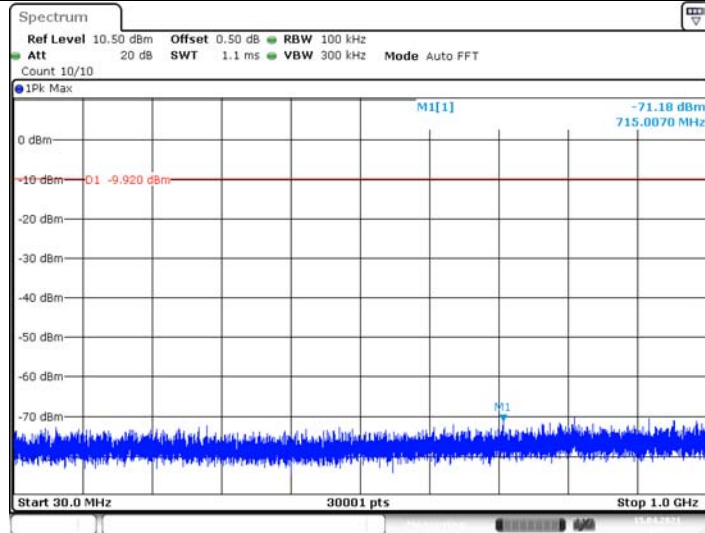

GFSK 2480 1000~26500

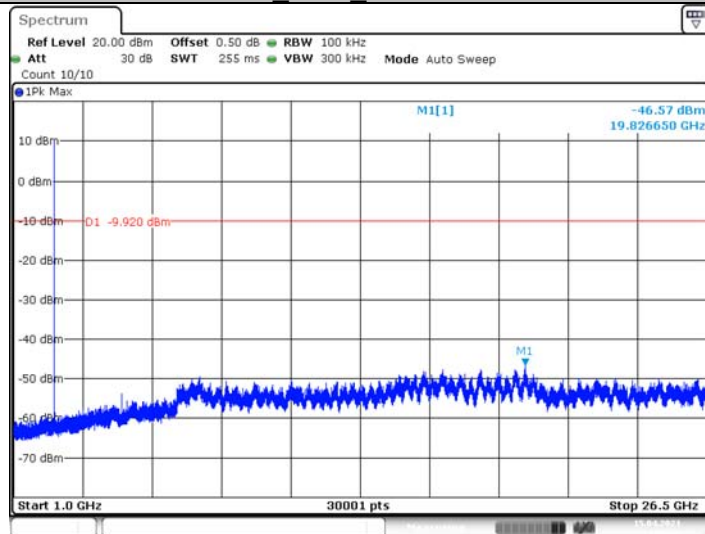

$\pi/4$ -DQPSK_2402_0~Reference

CTC Laboratories, Inc.

1-2/F., Building 2, Jiaquan Building, Guanlan High-Tech Park, Shenzhen, Guangdong, China

Tel.: (86)755-27521059

Fax: (86)755-27521011

Http://www.sz-ctc.org.cn



For anti-fake verification, please visit the official website of Certification and Accreditation Administration of the People's Republic of China : yz.cnca.cn

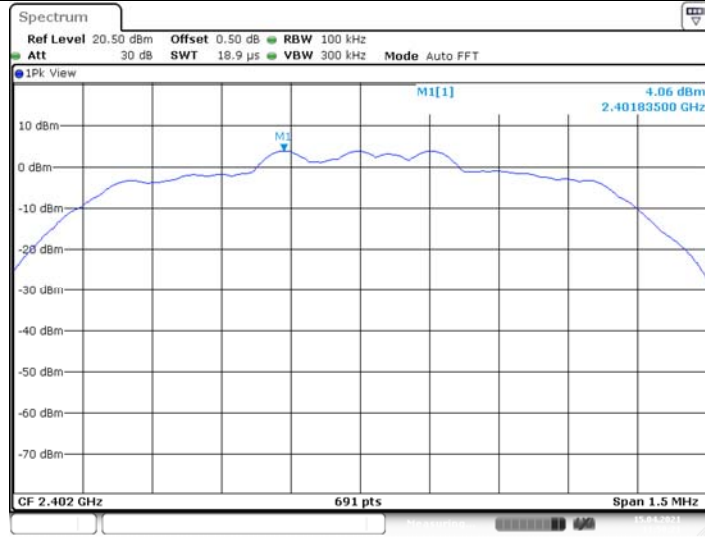

Date: 15.APR.2021 11:50:22

$\pi/4$ -DQPSK_2402_30~1000

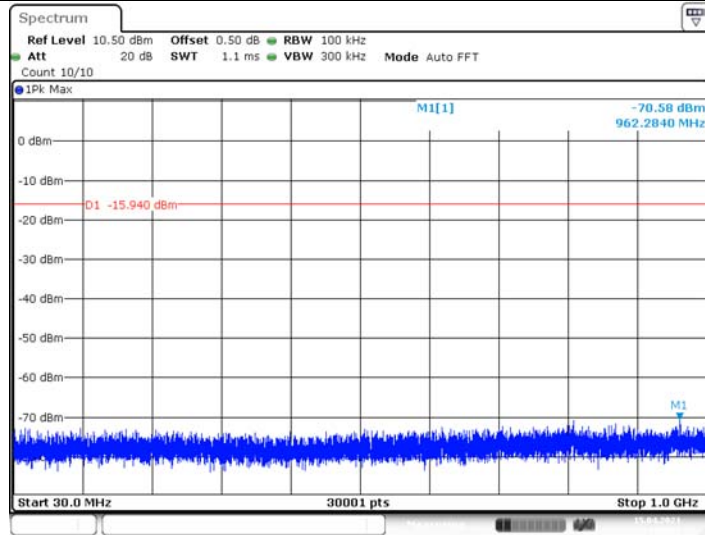

Date: 15.APR.2021 11:50:31

$\pi/4$ -DQPSK_2402_1000~26500

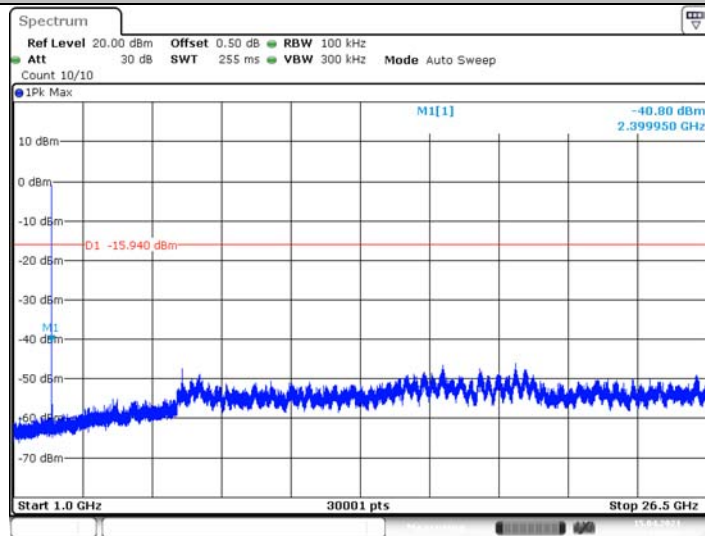

Date: 15.APR.2021 11:50:59

$\pi/4$ -DQPSK_2441_0~Reference

CTC Laboratories, Inc.

1-2/F., Building 2, Jiaquan Building, Guanlan High-Tech Park, Shenzhen, Guangdong, China
Tel.: (86)755-27521059 Fax: (86)755-27521011 Http://www.sz-ctc.org.cn



For anti-fake verification, please visit the official website of Certification and Accreditation Administration of the People's Republic of China : yz.cnca.cn

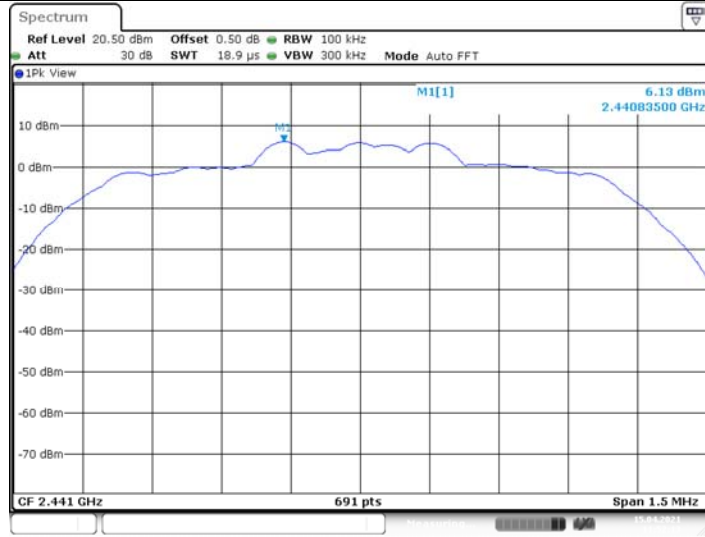

$\pi/4$ -DQPSK_2441_30~1000

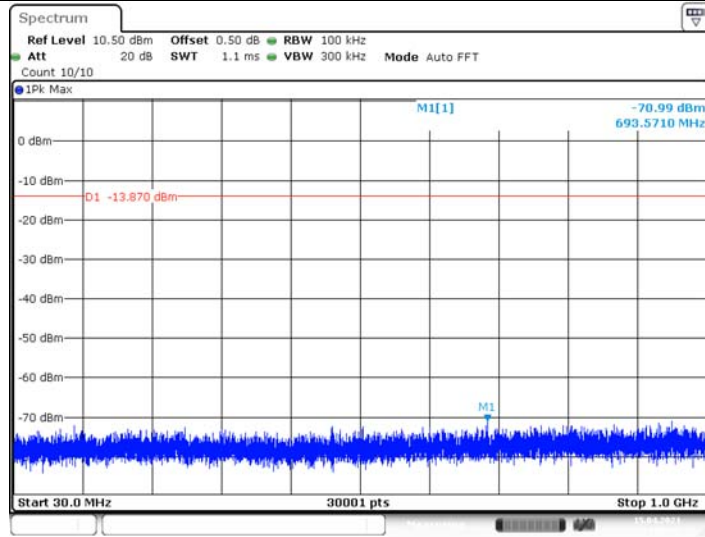

$\pi/4$ -DQPSK_2441_1000~26500

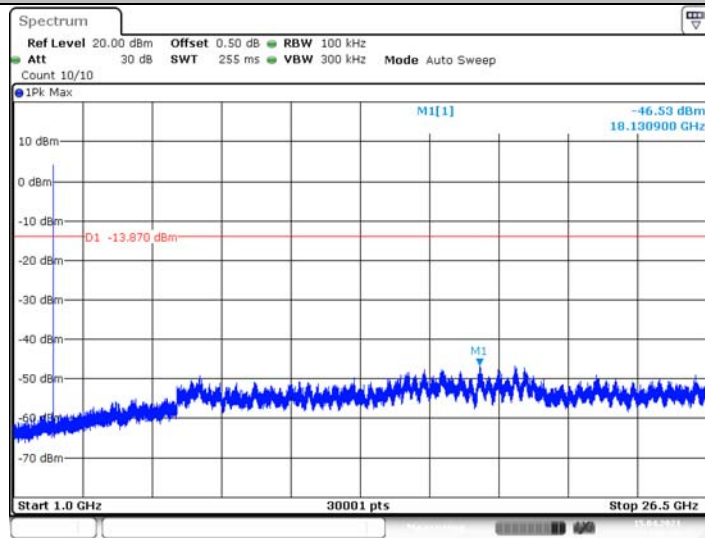

$\pi/4$ -DQPSK_2480_0~Reference

CTC Laboratories, Inc.

1-2/F., Building 2, Jiaquan Building, Guanlan High-Tech Park, Shenzhen, Guangdong, China
Tel.: (86)755-27521059 Fax: (86)755-27521011 Http://www.sz-ctc.org.cn



For anti-fake verification, please visit the official website of Certification and Accreditation Administration of the People's Republic of China : yz.cnca.cn

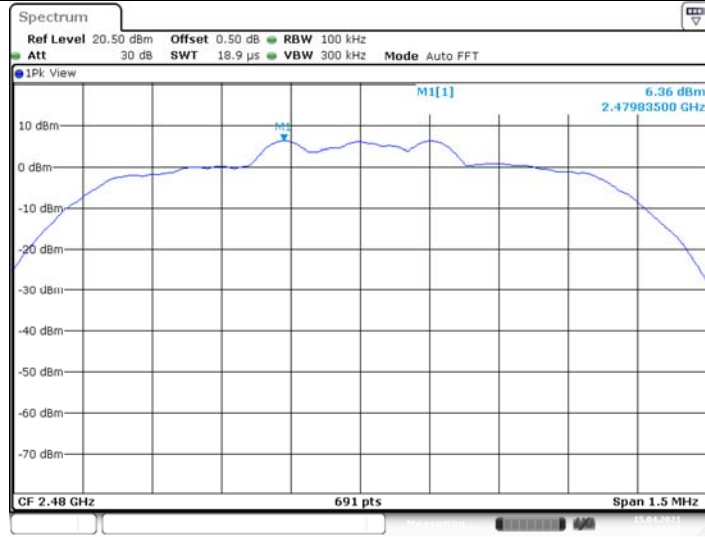

Date: 15.APR.2021 11:55:09

$\pi/4$ -DQPSK_2480_30~1000

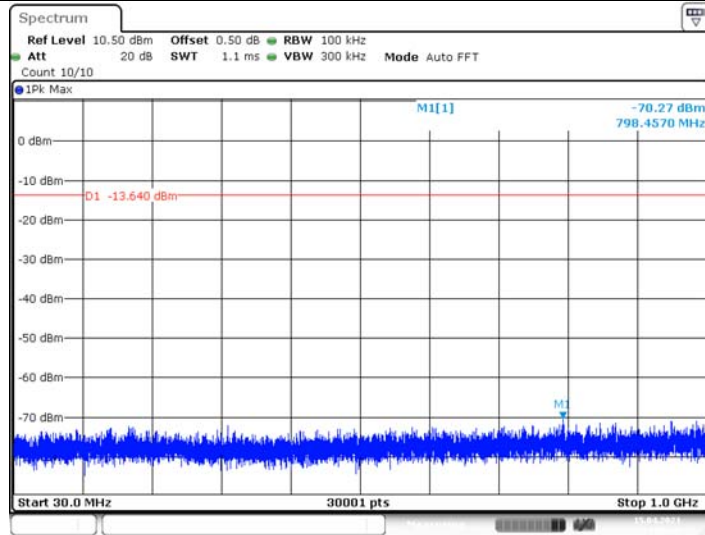

Date: 15.APR.2021 11:55:19

$\pi/4$ -DQPSK_2480_1000~26500

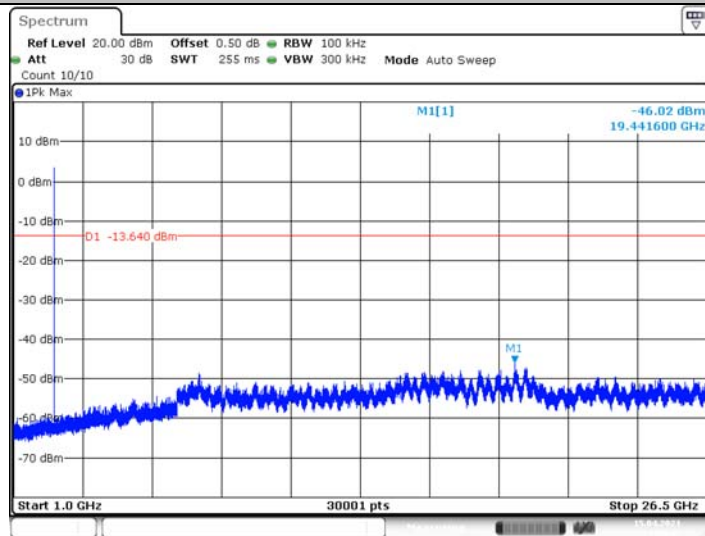

Date: 15.APR.2021 11:55:46

8-DPSK_2402_0~Reference

CTC Laboratories, Inc.

1-2/F., Building 2, Jiaquan Building, Guanlan High-Tech Park, Shenzhen, Guangdong, China
Tel.: (86)755-27521059 Fax: (86)755-27521011 Http://www.sz-ctc.org.cn



For anti-fake verification, please visit the official website of Certification and Accreditation Administration of the People's Republic of China : yz.cnca.cn

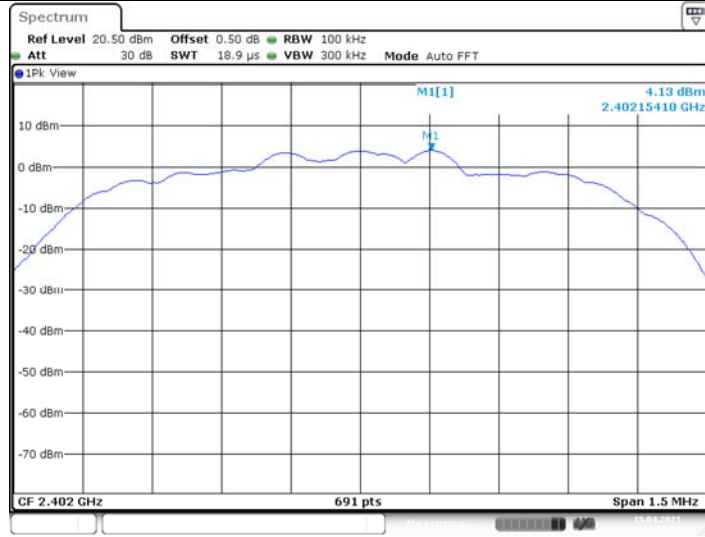

8-DPSK 2402 30~1000

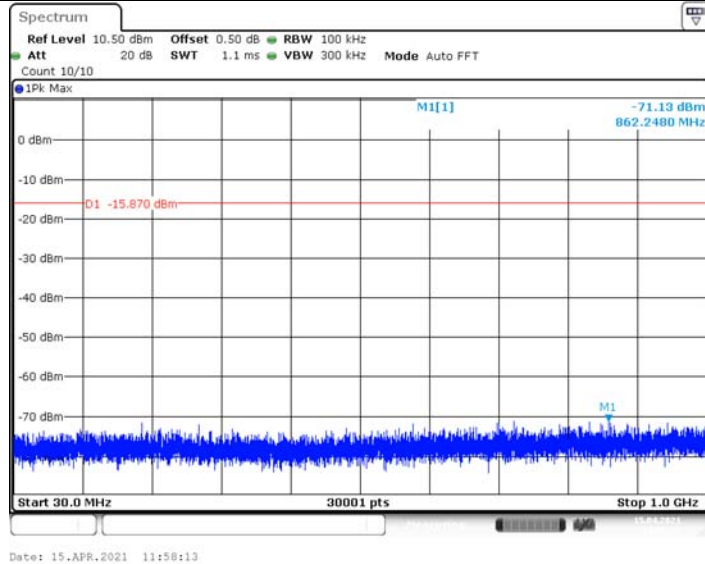

8-DPSK 2402 1000~26500

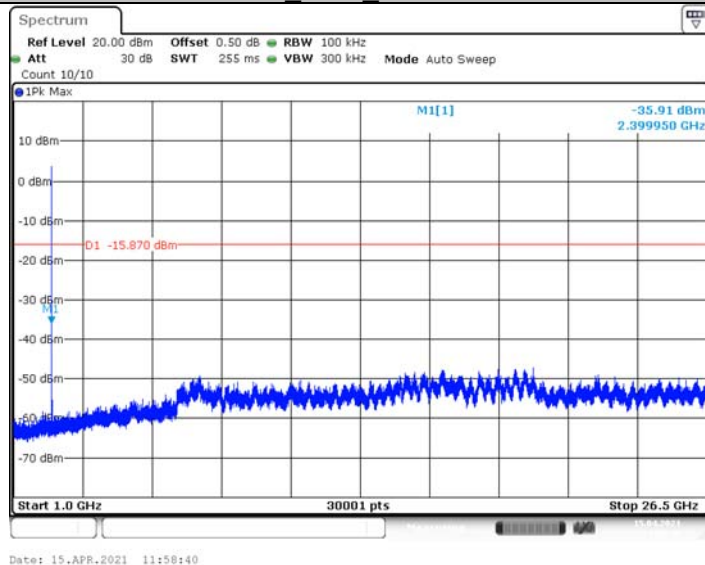

8-DPSK 2441 0~Reference



8-DPSK 2441 30~1000

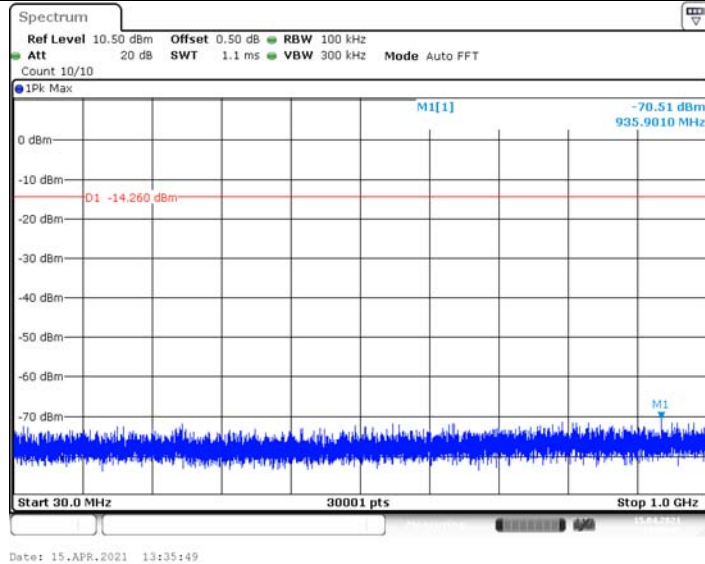

8-DPSK 2441 1000~26500

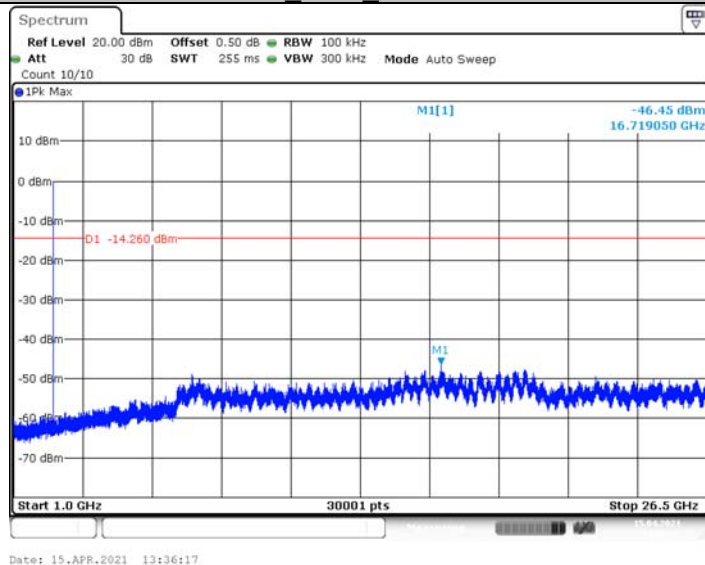

8-DPSK 2480 0~Reference

CTC Laboratories, Inc.

1-2/F., Building 2, Jiaquan Building, Guanlan High-Tech Park, Shenzhen, Guangdong, China
Tel.: (86)755-27521059 Fax: (86)755-27521011 Http://www.sz-ctc.org.cn



For anti-fake verification, please visit the official website of Certification and Accreditation Administration of the People's Republic of China : yz.cnca.cn

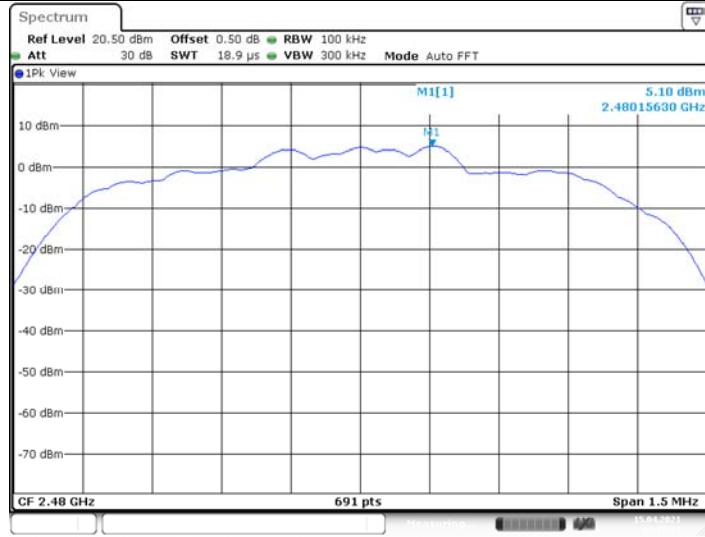

Date: 15.APR.2021 13:38:33

8-DPSK 2480 30~1000

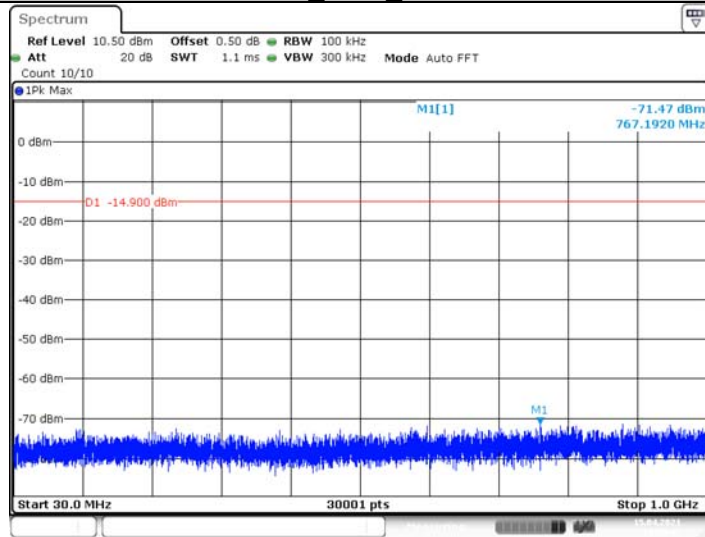

Date: 15.APR.2021 13:38:43

8-DPSK 2480 1000~26500

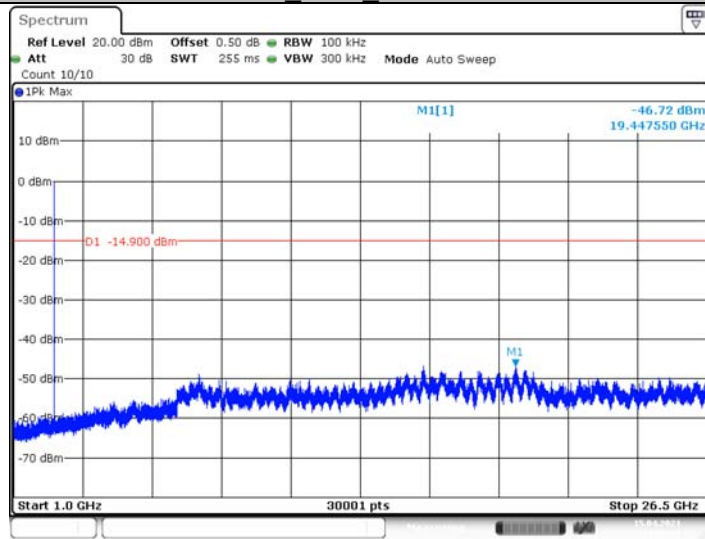

Date: 15.APR.2021 13:39:10



3.5. 20DB Bandwidth

Limit

N/A

Test Configuration

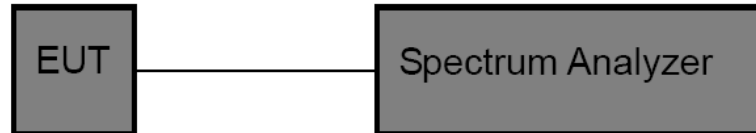

Test Procedure

- 5. The EUT was directly connected to the spectrum analyzer and antenna output port as show in the block diagram above.
- 6. OCB and 20dB Spectrum Setting:
 - (1) Set RBW = 1% ~ 5% occupied bandwidth.
 - (2) Set the video bandwidth (VBW) ≥ 3 RBW.
 - (3) Detector = Peak.
 - (4) Trace mode = Max hold.
 - (5) Sweep = Auto couple.

Note: The EUT was set to continuously transmitting in each mode and low, Middle and high channel for the test.

Test Mode

Please refer to the clause 2.4.

Test Results

Test Mode	Frequency[MHz]	20db EBW[MHz]	20dB Bandwidth *2/3 (kHz)	Verdict
GFSK	2402	0.870	580.00	PASS
	2441	0.864	576.00	PASS
	2480	0.864	576.00	PASS
π/4-DQPSK	2402	1.275	850.00	PASS
	2441	1.263	842.00	PASS
	2480	1.263	842.00	PASS
8-DPSK	2402	1.269	846.00	PASS
	2441	1.254	836.00	PASS
	2480	1.254	836.00	PASS





GFSK_2402

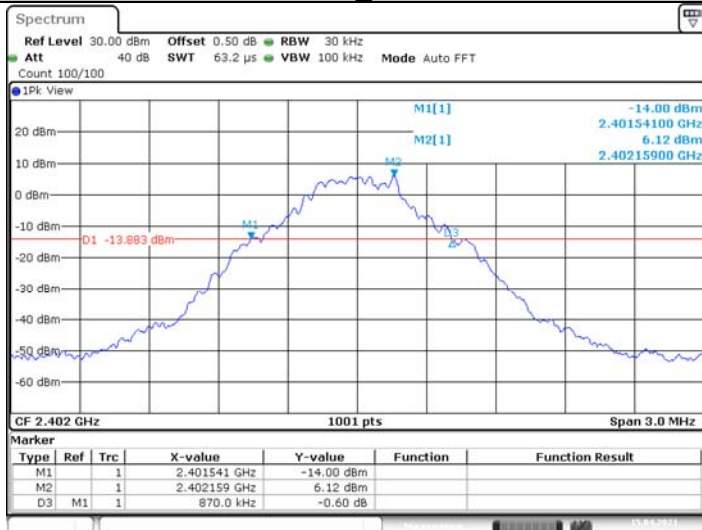

Date: 15.APR.2021 11:38:40

GFSK_2441

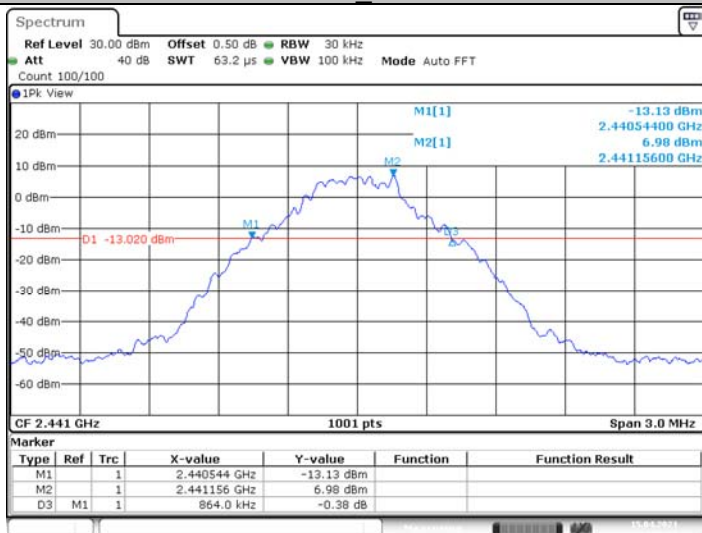

Date: 15.APR.2021 11:41:51

GFSK_2480

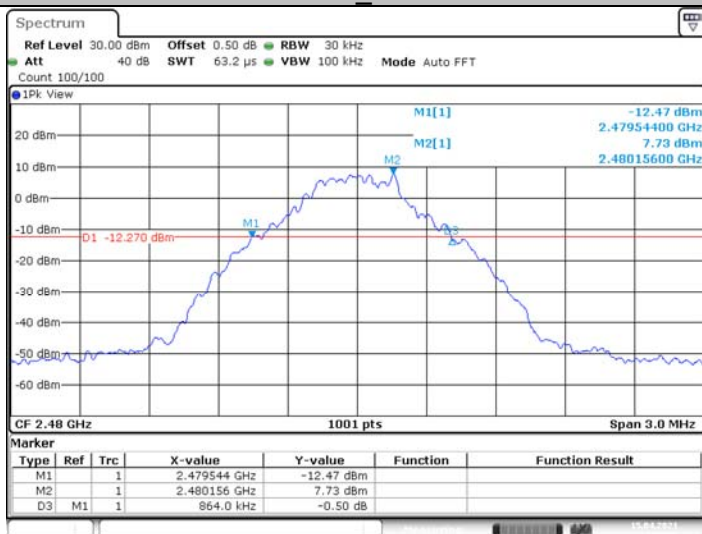

Date: 15.APR.2021 11:43:39

π/4-DQPSK_2402

CTC Laboratories, Inc.

1-2/F., Building 2, Jiaquan Building, Guanlan High-Tech Park, Shenzhen, Guangdong, China

Tel.: (86)755-27521059

Fax: (86)755-27521011

Http://www.sz-ctc.org.cn



For anti-fake verification, please visit the official website of Certification and Accreditation Administration of the People's Republic of China : yz.cnca.cn

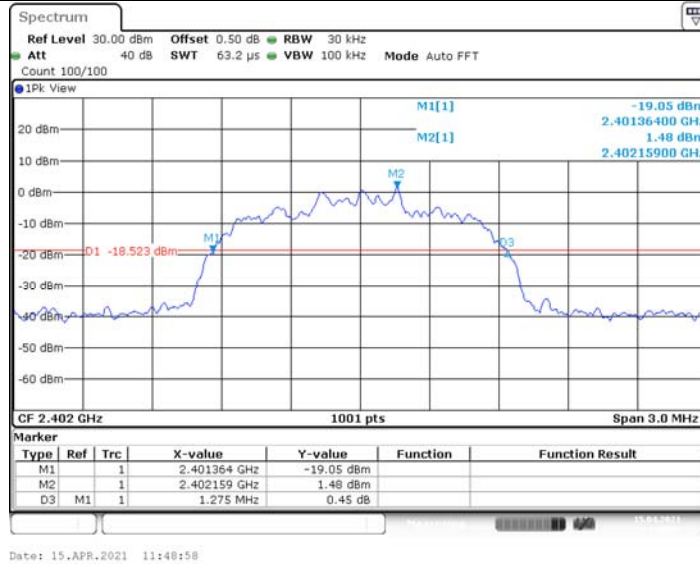

π/4-DQPSK_2441

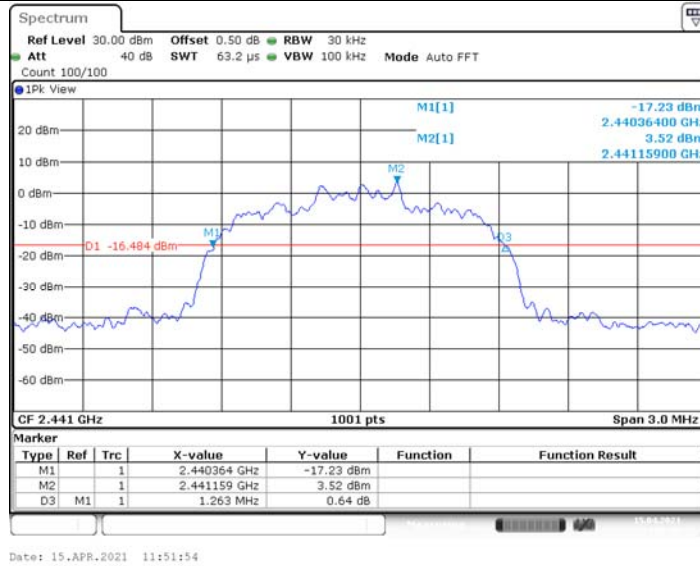

π/4-DQPSK_2480

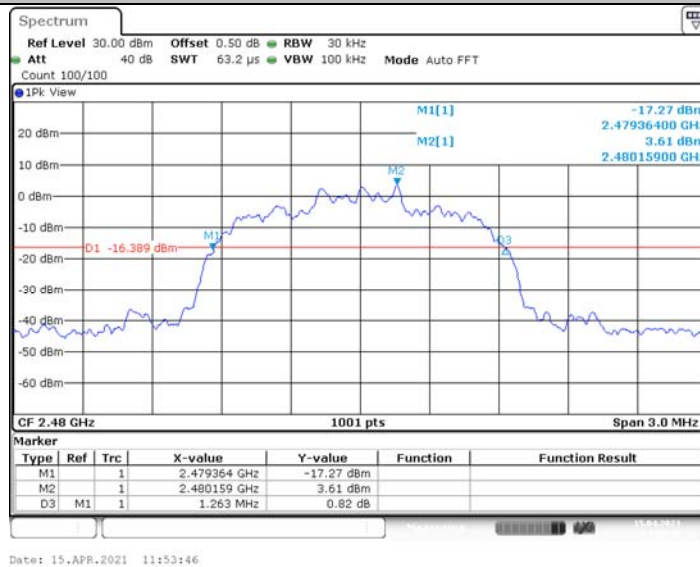

8-DPSK_2402

CTC Laboratories, Inc.

1-2/F., Building 2, Jiaquan Building, Guanlan High-Tech Park, Shenzhen, Guangdong, China
Tel.: (86)755-27521059 Fax: (86)755-27521011 Http://www.sz-ctc.org.cn



For anti-fake verification, please visit the official website of Certification and Accreditation Administration of the People's Republic of China : yz.cnca.cn

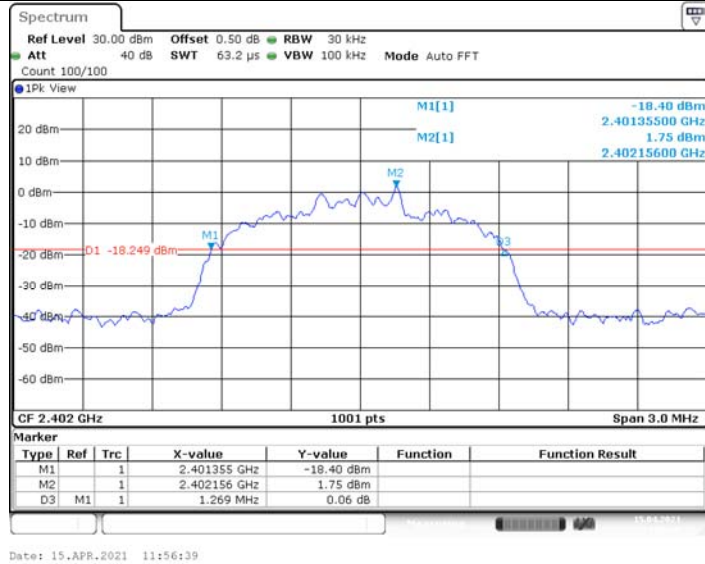

8-DPSK 2441

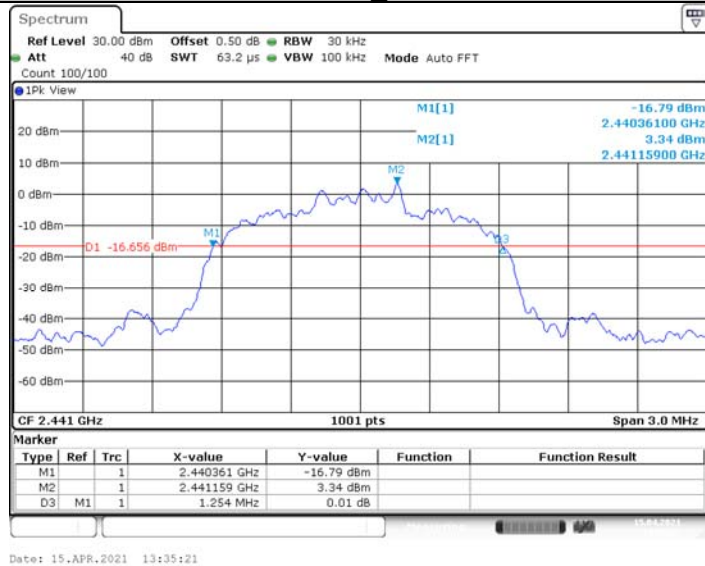

8-DPSK 2480

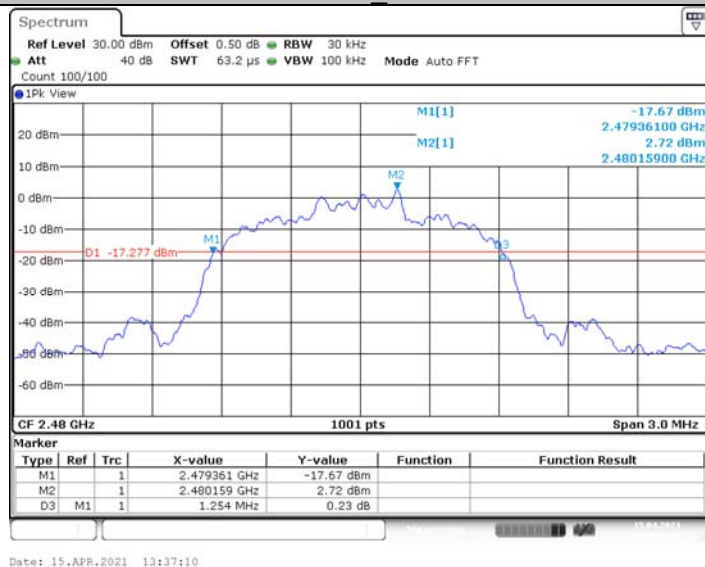



3.6. Channel Separation

Limit

FCC CFR Title 47 Part 15 Subpart C Section 15.247 (a)(1)/ RSS-247 5.1 b :

Test Item	Limit	Frequency Range(MHz)
Channel Separation	>25KHz or >two-thirds of the 20 dB bandwidth Which is greater	2400~2483.5

Test Configuration

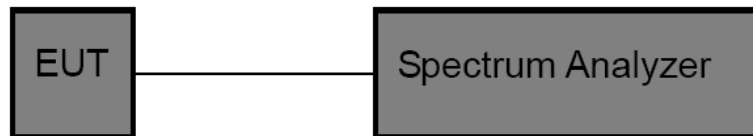

Test Procedure

7. The EUT was directly connected to the spectrum analyzer and antenna output port as show in the block diagram above.
8. Spectrum Setting:
 - (1) Set RBW = 100 kHz.
 - (2) Set the video bandwidth (VBW) ≥ 3 RBW.
 - (3) Detector = Peak.
 - (4) Trace mode = Max hold.
 - (5) Sweep = Auto couple.

Test Mode

Please refer to the clause 2.4.

**Test Results**

Test Mode	Frequency[MHz]	Result[MHz]	Limit[MHz]	Verdict
GFSK	Hop_2402	1.000	>580.00	PASS
	Hop_2441	0.952	>576.00	PASS
	Hop_2480	1.022	>576.00	PASS
$\pi/4$ -DQPSK	Hop_2402	0.996	>850.00	PASS
	Hop_2441	1.000	>842.00	PASS
	Hop_2480	0.982	>842.00	PASS
8-DPSK	Hop_2402	1.000	>846.00	PASS
	Hop_2441	1.004	>836.00	PASS
	Hop_2480	1.007	>836.00	PASS



GFSK Hop_2402



Date: 15.APR.2021 13:41:33

GFSK Hop_2441

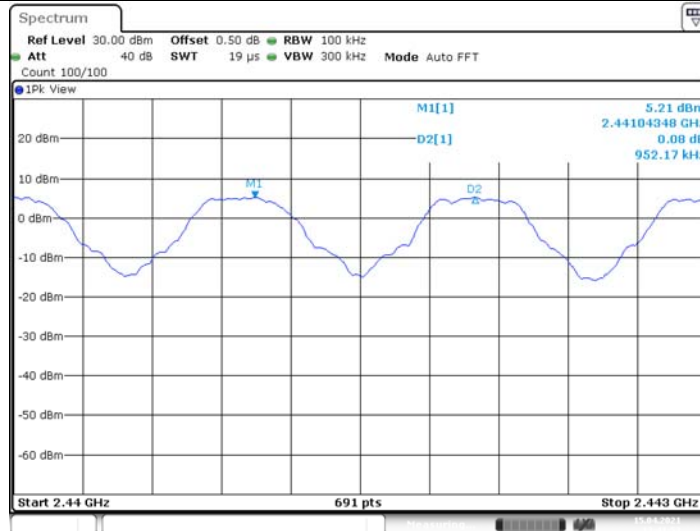

Date: 15.APR.2021 13:41:53

GFSK Hop_2480

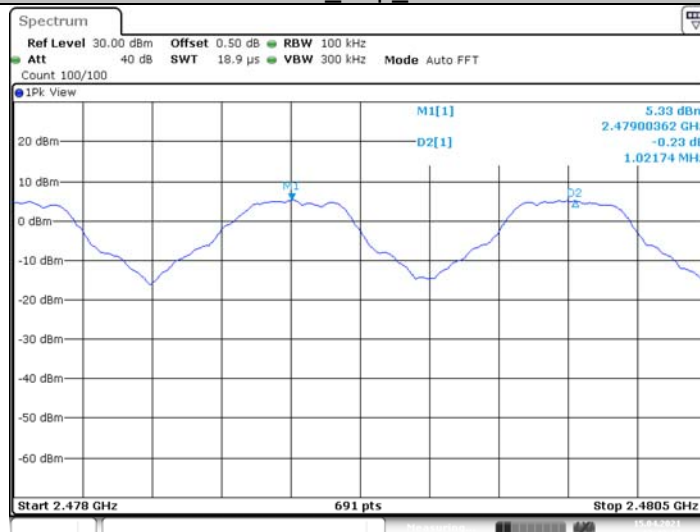

Date: 15.APR.2021 13:42:17

π/4-DQPSK_Hop_2402

CTC Laboratories, Inc.

1-2/F., Building 2, Jiaquan Building, Guanlan High-Tech Park, Shenzhen, Guangdong, China

Tel.: (86)755-27521059

Fax: (86)755-27521011

Http://www.sz-ctc.org.cn



For anti-fake verification, please visit the official website of Certification and Accreditation Administration of the People's Republic of China : yz.cnca.cn



$\pi/4$ -DQPSK_Hop_2441

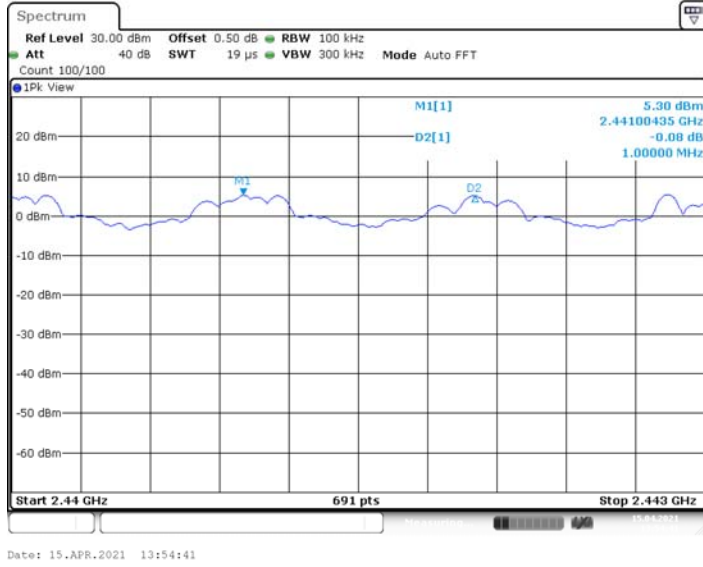

$\pi/4$ -DQPSK_Hop_2480

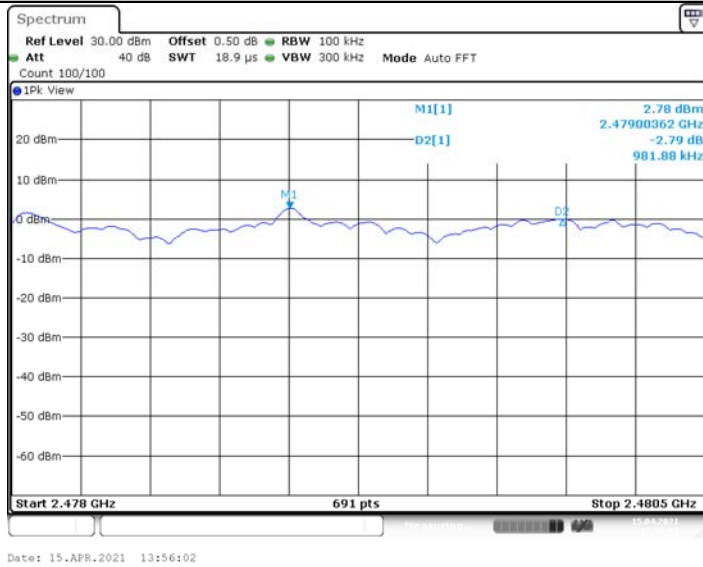

8-DPSK_Hop_2402



8-DPSK Hop 2441

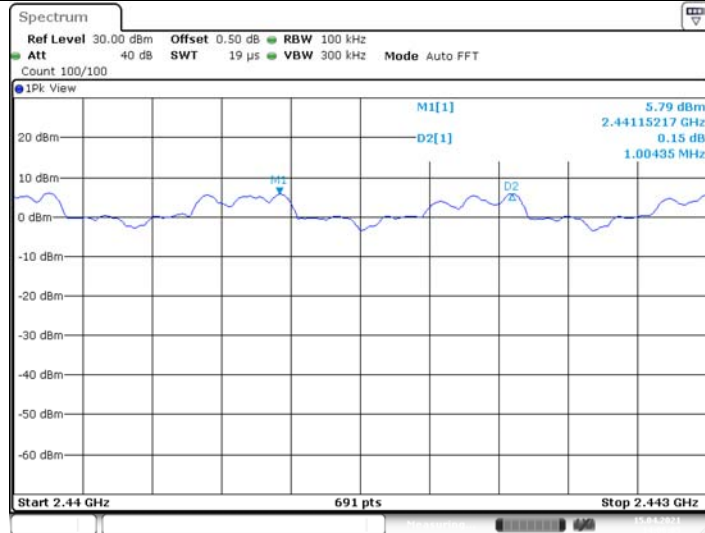

8-DPSK Hop 2480

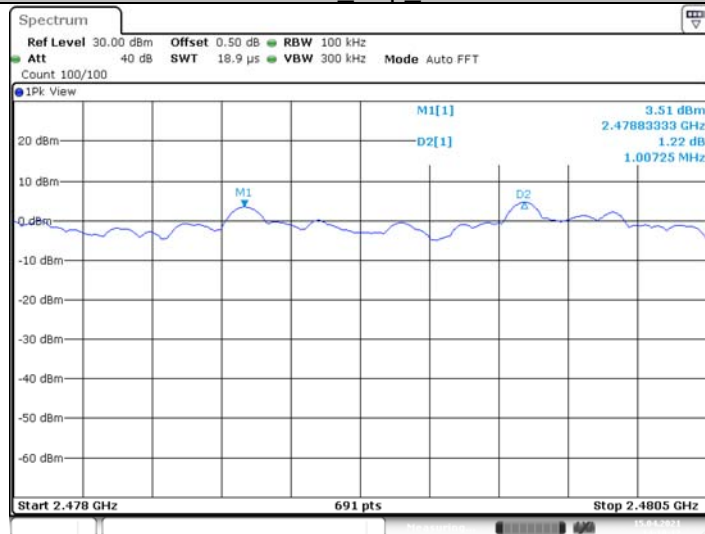



3.7. Number of Hopping Channel

Limit

FCC CFR Title 47 Part 15 Subpart C Section 15.247 (a)(iii)/ RSS-247 5.1 d:

Section	Test Item	Limit
15.247 (a)(iii)/ RSS-247 5.1 d:	Number of Hopping Channel	>15

Test Configuration

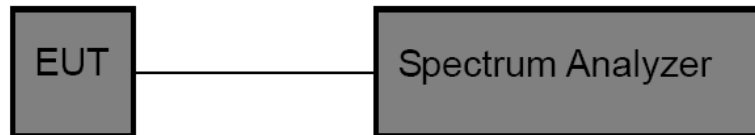

Test Procedure

- The EUT was directly connected to the spectrum analyzer and antenna output port as show in the block diagram above.
- Spectrum Setting:
 - Peak Detector: RBW=100 kHz, VBW \geq RBW, Sweep time= Auto.

Test Mode

Please refer to the clause 2.4.

Test Result

Modulation type	Channel number	Limit	Result
GFSK	79	≥15.00	Pass
$\pi/4$ -DQPSK	79		
8DPSK	79		



<p>GFSK</p>	<p>Spectrum Ref Level 30.00 dBm Offset 0.50 dB RBW 100 kHz Att 40 dB SWT 94.8 μs VBW 300 kHz Mode Auto FFT 1PK View D1[1] 1.91 dB M1[1] 78.300 MHz 3.63 dBm 2.401870 GHz Start 2.4 GHz 691 pts Stop 2.4835 GHz Date: 15.APR.2021 13:42:44</p>
<p>$\pi/4$-DQPSK</p>	<p>Spectrum Ref Level 30.00 dBm Offset 0.50 dB RBW 100 kHz Att 40 dB SWT 94.8 μs VBW 300 kHz Mode Auto FFT 1PK View M1[1] 1.62 dBm D1[1] 2.402110 GHz 1.32 dB 77.940 MHz Start 2.4 GHz 691 pts Stop 2.4835 GHz Date: 15.APR.2021 13:57:20</p>
<p>8-DPSK</p>	<p>Spectrum Ref Level 30.00 dBm Offset 0.50 dB RBW 100 kHz Att 40 dB SWT 94.8 μs VBW 300 kHz Mode Auto FFT 1PK View D1[1] 1.77 dB M1[1] 78.180 MHz 1.67 dBm 2.401870 GHz Start 2.4 GHz 691 pts Stop 2.4835 GHz Date: 15.APR.2021 14:11:24</p>



3.8. Dwell Time

Limit

Section	Test Item	Limit
15.247(a)(iii)/ RSS-247 5.1 d	Average Time of Occupancy	0.4 sec

Test Configuration

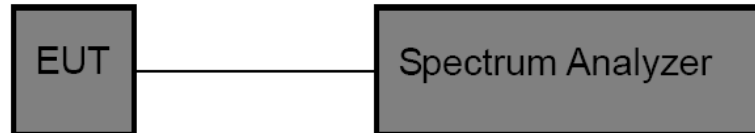

Test Procedure

1. The EUT was directly connected to the spectrum analyzer and antenna output port as show in the block diagram above.
2. Spectrum Setting:
 - (1) Spectrum Setting: RBW=1MHz, VBW \geq RBW.
 - (2) Use video trigger with the trigger level set to enable triggering only on full pulses.
 - (3) Sweep Time is more than once pulse time.
 - (4) Set the center frequency on any frequency would be measure and set the frequency span to zero.
 - (5) Measure the maximum time duration of one single pulse.
 - (6) Set the EUT for packet transmitting.

Test Mode

Please refer to the clause 2.4.

**Test Result**

Modulation type	Channel	Frequency [MHz]	Pulse Time (ms)	Total of Dwell (ms)	Period Time (ms)	Limit (Second)	Result
GFSK	DH1	2441	0.37	118.40	31.60	≤ 0.40	Pass
	DH3	2441	1.63	260.80	31.60		
	DH5	2441	2.87	306.13	31.60		
π/4-DQPSK	2DH1	2441	0.38	121.60	31.60	≤ 0.40	Pass
	2DH3	2441	1.63	260.80	31.60		
	2DH5	2441	2.87	306.13	31.60		
8-DPSK	3DH1	2441	0.38	121.60	31.60	≤ 0.40	Pass
	3DH3	2441	1.63	260.80	31.60		
	3DH5	2441	2.88	307.20	31.60		

Note: 1DH1/2DH1/3DH1 Total of Dwell= Pulse Time*(1600/2)*31.6/79

1DH3/2DH3/3DH3 Total of Dwell= Pulse Time*(1600/4)*31.6/79

1DH5/2DH5/3DH5 Total of Dwell= Pulse Time*(1600/6)*31.6/79



Modulation Type: GFSK	
DH1	<p>Spectrum Ref Level 30.00 dBm RBW 1 MHz Att 40 dB SWT 10 ms VBW 3 MHz SQL TRG:VID 1PK Clrw M1[1] -3.85 dBm D2[1] -1.23 µs 8.79 dB 373.80 µs TRG 2.700 dBm CF 2.441 GHz 8000 pts 1.0 ms/ Date: 15.APR.2021 14:14:10</p>
DH3	<p>Spectrum Ref Level 30.00 dBm RBW 1 MHz Att 40 dB SWT 20 ms VBW 3 MHz SQL TRG:VID 1PK Clrw M1[1] -0.33 dBm D2[1] -2.48 µs 5.59 dB 1.62520 ms TRG 2.600 dBm CF 2.441 GHz 8000 pts 2.0 ms/ Date: 15.APR.2021 14:14:49</p>
DH5	<p>Spectrum Ref Level 30.00 dBm RBW 1 MHz Att 40 dB SWT 30 ms VBW 3 MHz SQL TRG:VID 1PK Clrw M1[1] -1.54 dBm D2[1] -4.98 µs 6.90 dB 2.86911 ms TRG 2.500 dBm CF 2.441 GHz 8000 pts 3.0 ms/ Date: 15.APR.2021 13:42:59</p>



Modulation Type:		$\pi/4$ -DQPSK
2DH1		<p>Spectrum Ref Level 30.00 dBm Att 40 dB RBW 1 MHz SWT 10 ms VBW 3 MHz</p> <p>SGL TRG:VID 1Pk ClrW</p> <p>M1[1] 0.85 dBm D2[1] -1.23 μs TRG 2.500 dBm 1.75 dB 381.30 μs</p> <p>CF 2.441 GHz 8000 pts 1.0 ms/</p> <p>Date: 15.APR.2021 14:16:11</p>
2DH3		<p>Spectrum Ref Level 30.00 dBm Att 40 dB RBW 1 MHz SWT 20 ms VBW 3 MHz</p> <p>SGL TRG:VID 1Pk ClrW</p> <p>M1[1] -1.02 dBm D2[1] -2.48 μs TRG 2.500 dBm 4.60 dB 1.62770 ms</p> <p>CF 2.441 GHz 8000 pts 2.0 ms/</p> <p>Date: 15.APR.2021 14:16:44</p>
2DH5		<p>Spectrum Ref Level 30.00 dBm Att 40 dB RBW 1 MHz SWT 30 ms VBW 3 MHz</p> <p>SGL TRG:VID 1Pk ClrW</p> <p>M1[1] -2.22 dBm D2[1] -4.98 μs TRG 2.400 dBm 6.16 dB 2.87286 ms</p> <p>CF 2.441 GHz 8000 pts 3.0 ms/</p> <p>Date: 15.APR.2021 14:15:27</p>



Modulation Type:		8-DPSK
3DH1	<p>Ref Level 30.00 dBm Att 40 dB RBW 1 MHz SWT 10 ms VBW 3 MHz</p> <p>M1[1] -14.86 dBm -2.48 μs D2[1] 17.64 dB 382.55 μs</p> <p>TRG 2.500 dBm</p> <p>CF 2.441 GHz 8000 pts 1.0 ms/</p> <p>Date: 15.APR.2021 14:17:23</p>	
3DH3	<p>Ref Level 30.00 dBm Att 40 dB RBW 1 MHz SWT 20 ms VBW 3 MHz</p> <p>M1[1] -2.32 dBm -2.48 μs D2[1] 6.16 dB 1.62770 ms</p> <p>TRG 2.500 dBm</p> <p>CF 2.441 GHz 8000 pts 2.0 ms/</p> <p>Date: 15.APR.2021 14:17:59</p>	
3DH5	<p>Ref Level 30.00 dBm Att 40 dB RBW 1 MHz SWT 30 ms VBW 3 MHz</p> <p>M1[1] 2.92 dBm -4.98 μs D2[1] 0.94 dB 2.87661 ms</p> <p>TRG 2.800 dBm</p> <p>CF 2.441 GHz 8000 pts 3.0 ms/</p> <p>Date: 15.APR.2021 14:11:38</p>	



3.9. Peak Output Power

Limit

FCC CFR Title 47 Part 15 Subpart C Section 15.247 (b)(1) / RSS-247 5.4 b:

Test Item	Limit	Frequency Range(MHz)
Peak Output Power	Hopping Channels>75 Power<1W(30dBm) Other <125mW(21dBm)	2400~2483.5

Test Configuration

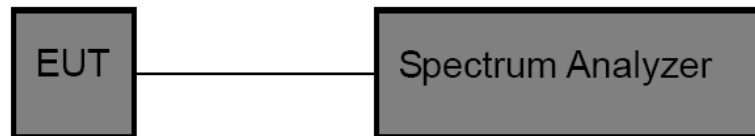

Test Procedure

- The EUT was directly connected to the spectrum analyzer and antenna output port as show in the block diagram above.
- Spectrum Setting:
 - Set RBW> 20DB Bandwidth.
 - Set the video bandwidth (VBW) ≥ RBW.
 - Detector = Peak.
 - Trace mode = Max hold.
 - Sweep = Auto couple.

Test Mode

Please refer to the clause 2.4.

Test Result

Test Mode	Frequency[MHz]	Result[dBm]	Limit[dBm]	Verdict
GFSK	2402	4.81	<=30	PASS
	2441	7.42	<=30	PASS
	2480	6.90	<=30	PASS
π/4-DQPSK	2402	5.18	<=30	PASS
	2441	6.24	<=30	PASS
	2480	6.56	<=30	PASS
8-DPSK	2402	4.60	<=30	PASS
	2441	5.85	<=30	PASS
	2480	5.21	<=30	PASS



GFSK_2402

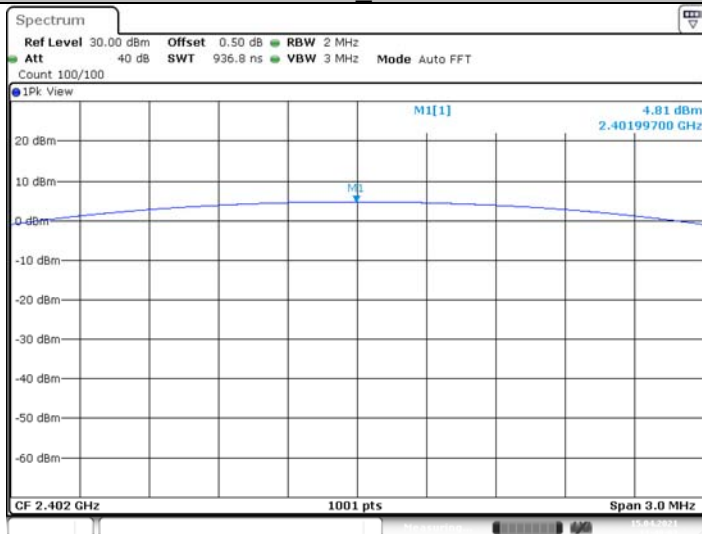

Date: 15.APR.2021 11:48:03

GFSK_2441

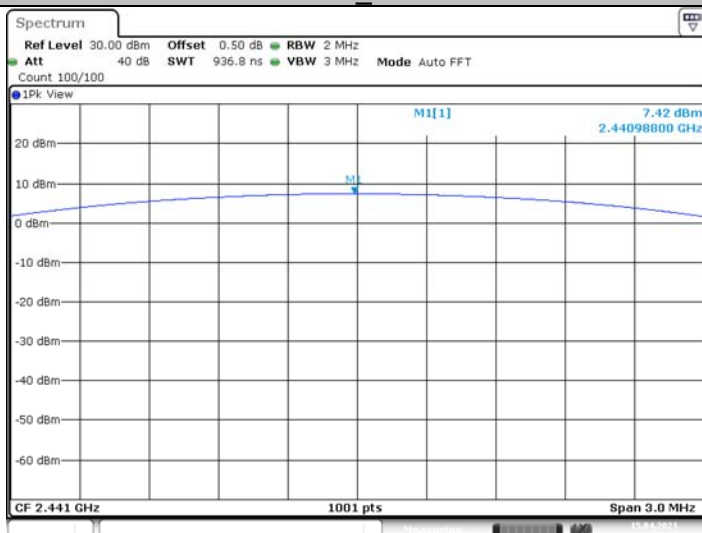

Date: 15.APR.2021 11:47:30

GFSK_2480

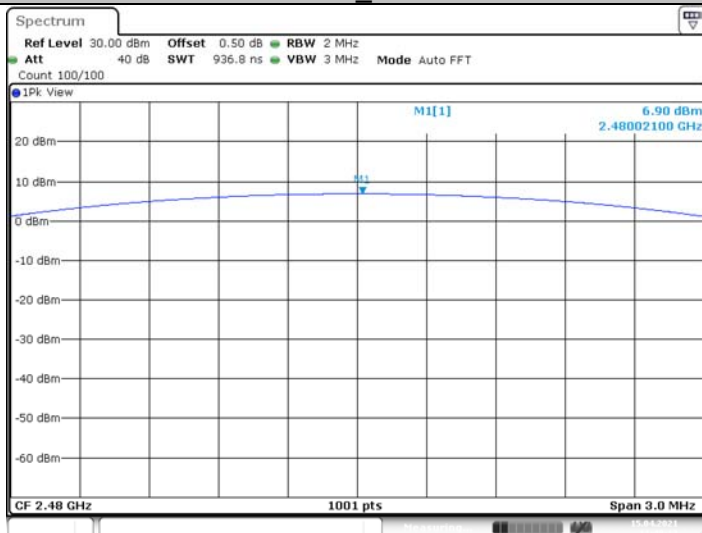

Date: 15.APR.2021 11:48:13

$\pi/4$ -DQPSK_2402

CTC Laboratories, Inc.

1-2/F., Building 2, Jiaquan Building, Guanlan High-Tech Park, Shenzhen, Guangdong, China

Tel.: (86)755-27521059

Fax: (86)755-27521011

Http://www.sz-ctc.org.cn



For anti-fake verification, please visit the official website of Certification and Accreditation Administration of the People's Republic of China : yz.cnca.cn

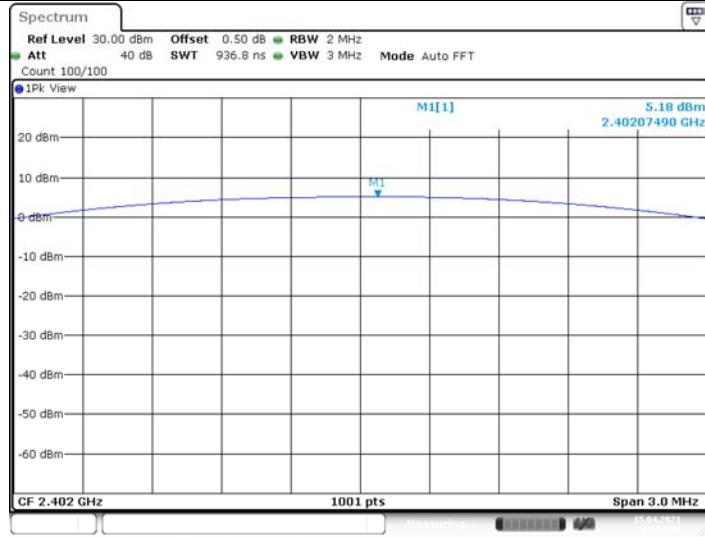

Date: 15.APR.2021 11:51:06

$\pi/4$ -DQPSK_2441

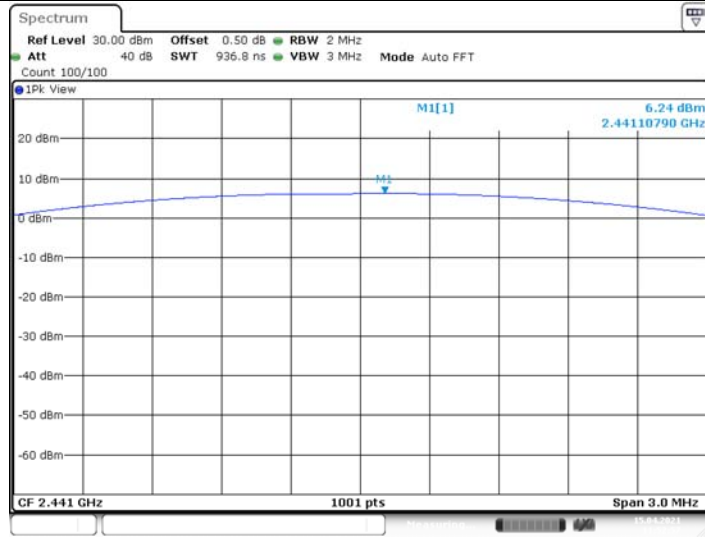

Date: 15.APR.2021 11:52:57

$\pi/4$ -DQPSK_2480

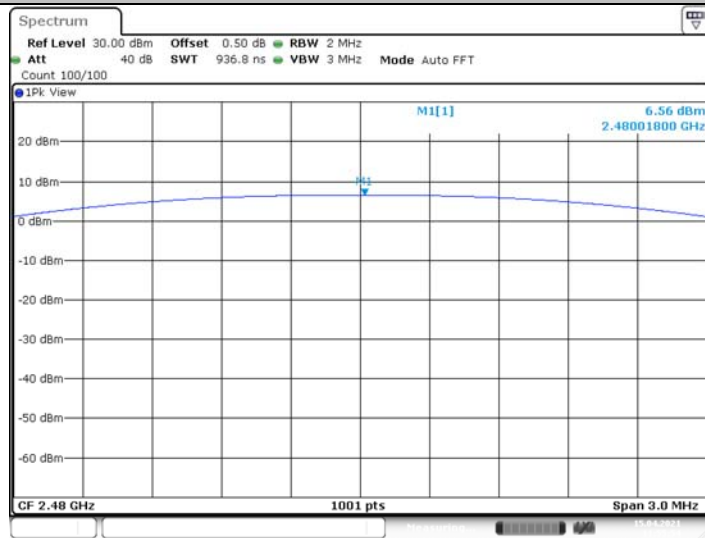

Date: 15.APR.2021 11:55:54

8-DPSK_2402

CTC Laboratories, Inc.

1-2/F., Building 2, Jiaquan Building, Guanlan High-Tech Park, Shenzhen, Guangdong, China
Tel.: (86)755-27521059

Fax: (86)755-27521011 Http://www.sz-ctc.org.cn
For anti-fake verification, please visit the official website of Certification and Accreditation Administration of the People's Republic of China : yz.cnca.cn



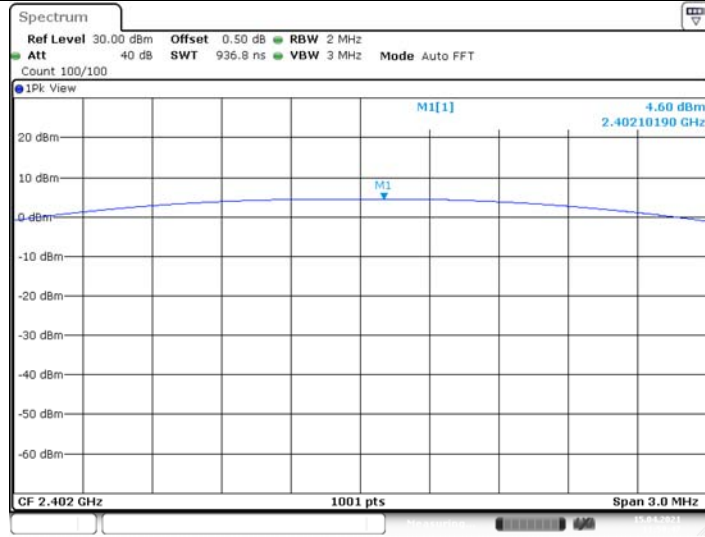

Date: 15.APR.2021 11:58:48

8-DPSK 2441



Date: 15.APR.2021 13:36:24

8-DPSK 2480

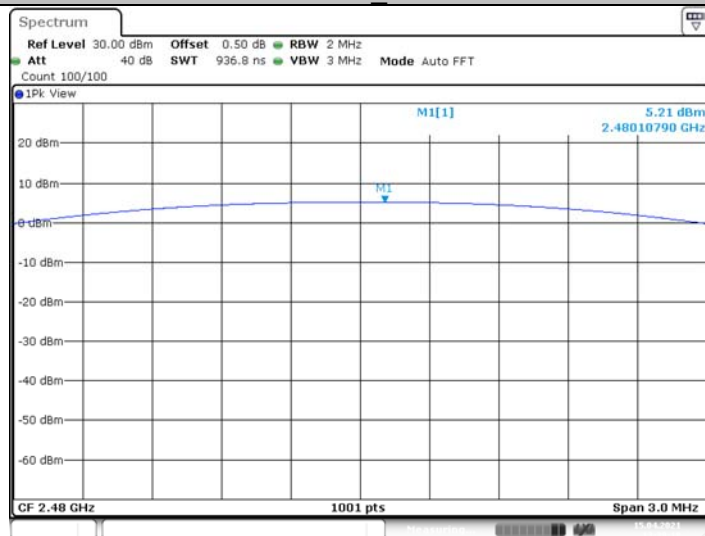

Date: 15.APR.2021 13:39:18



3.10. Duty Cycle

Limit

None, for report purposes only.

Test Configuration

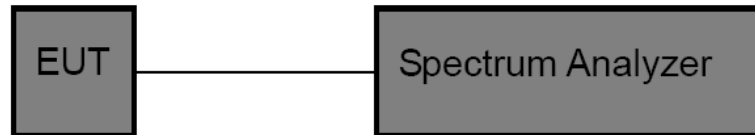

Test Procedure

1. The EUT was directly connected to the spectrum analyzer and antenna output port as show in the block diagram above.
2. The EUT was directly connected to the Spectrum Analyzer and antenna output port as show in the block diagram above. The measurement according to section 10.2 of KDB 558074 D01 DTS Meas Guidance v05r02.
3. Spectrum Setting:
Set analyzer center frequency to test channel center frequency.
Set the span to 0Hz
Set the RBW to 10MHz
Set the VBW to 10MHz
Detector: Peak
Sweep time: Auto
Allow trace to fully stabilize. Then use the peak marker function to determine the maximum amplitude level.

Test Mode

Please refer to the clause 2.4.

Test Result

Test Mode	Frequency [MHz]	Transmission Duration [ms]	Transmission Period [ms]	Duty Cycle [%]	1/T Minimum VBW (kHz)	Final setting For VBW (kHz)
GFSK	2402	2.86	3.73	76.83	0.35	1
	2441	2.86	3.73	76.82	0.35	1
	2480	2.86	3.73	76.82	0.35	1
$\pi/4$ -DQPSK	2402	2.87	3.73	76.89	0.35	1
	2441	2.87	3.73	76.89	0.35	1
	2480	2.87	3.73	76.89	0.35	1
8-DPSK	2402	2.87	3.73	76.95	0.35	1
	2441	2.87	3.73	76.95	0.35	1
	2480	2.87	3.73	76.95	0.35	1



GFSK_2402

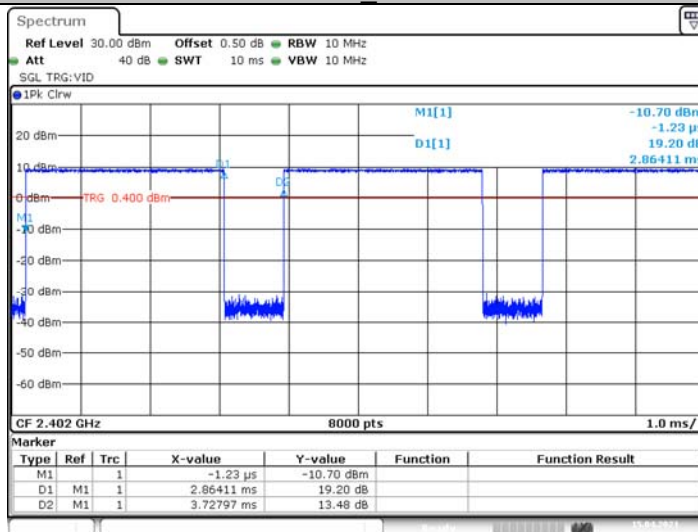

Date: 15.APR.2021 11:38:19

GFSK_2441

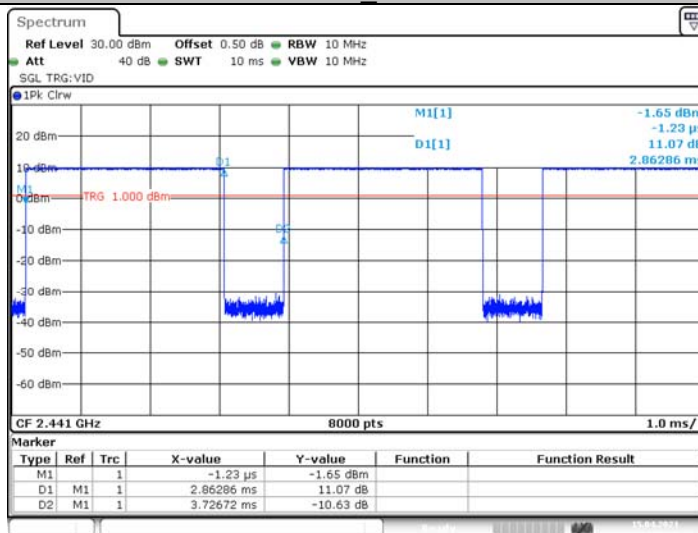

Date: 15.APR.2021 11:41:30

GFSK_2480

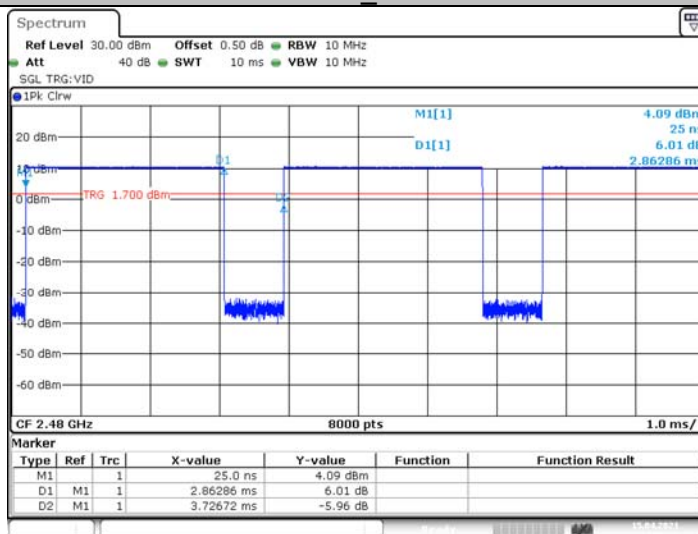

Date: 15.APR.2021 11:43:17

$\pi/4$ -DQPSK_2402



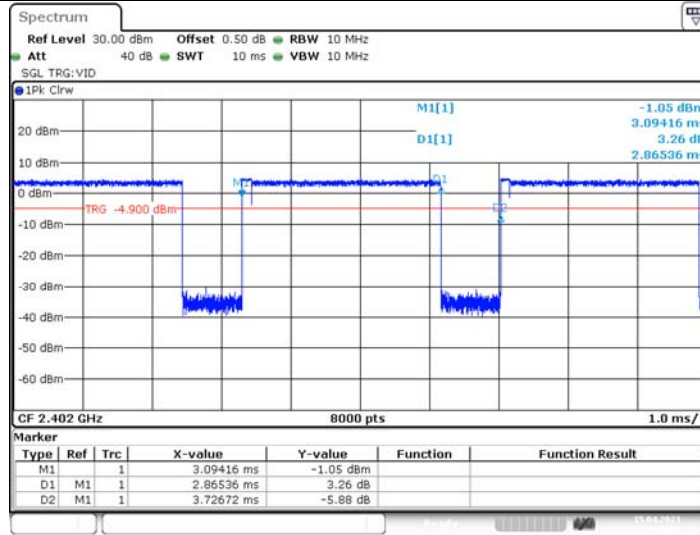

Date: 15.APR.2021 11:48:36

$\pi/4$ -DQPSK_2441

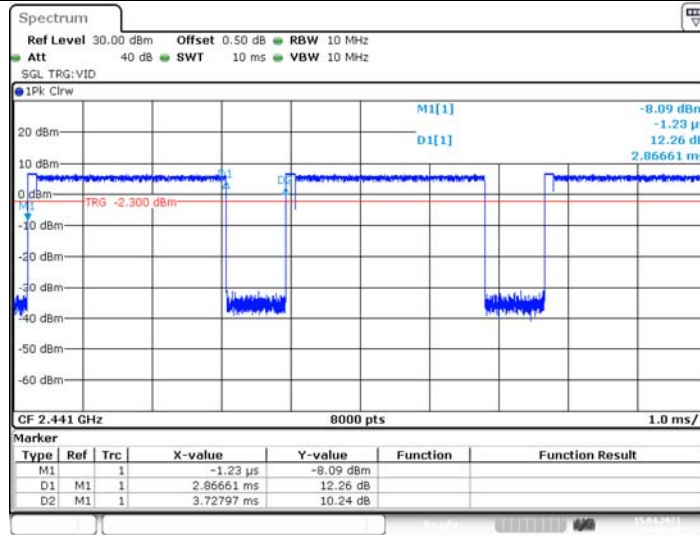

Date: 15.APR.2021 11:51:32

$\pi/4$ -DQPSK_2480

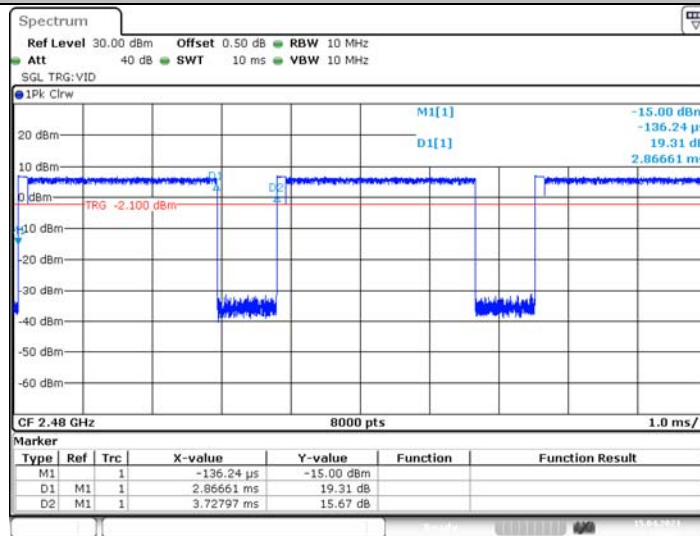

Date: 15.APR.2021 11:53:24

8-DPSK_2402

CTC Laboratories, Inc.

1-2/F., Building 2, Jiaquan Building, Guanlan High-Tech Park, Shenzhen, Guangdong, China
Tel.: (86)755-27521059

Fax: (86)755-27521011 Http://www.sz-ctc.org.cn
For anti-fake verification, please visit the official website of Certification and Accreditation Administration of the People's Republic of China : yz.cnca.cn



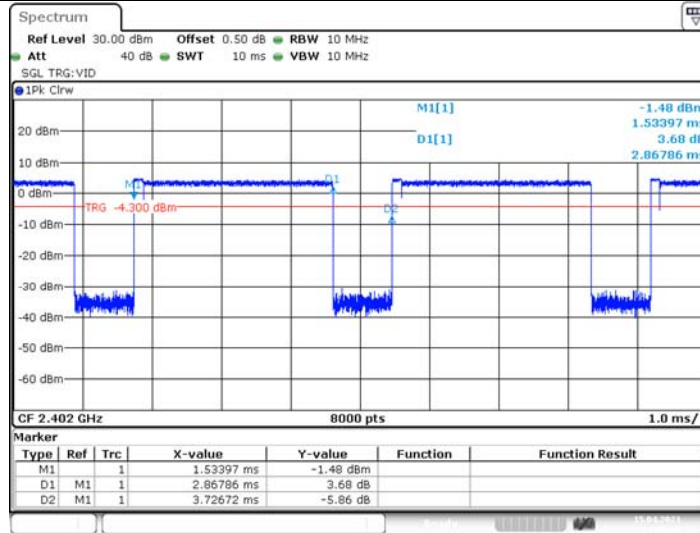

Date: 15.APR.2021 11:56:18

8-DPSK 2441

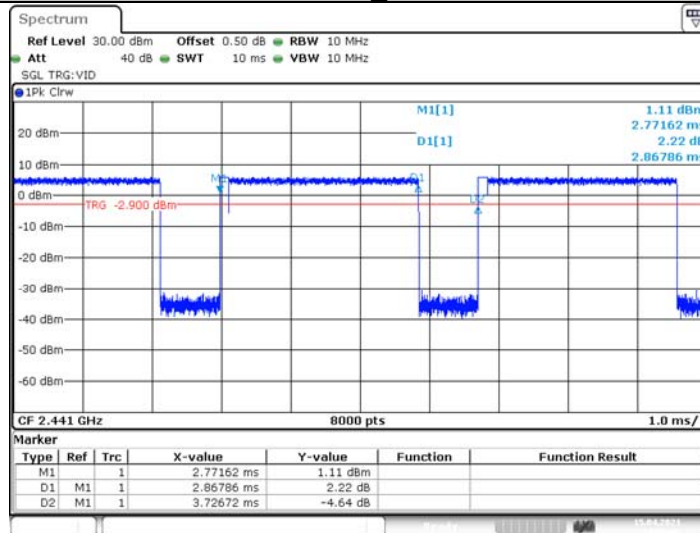

Date: 15.APR.2021 13:34:59

8-DPSK 2480

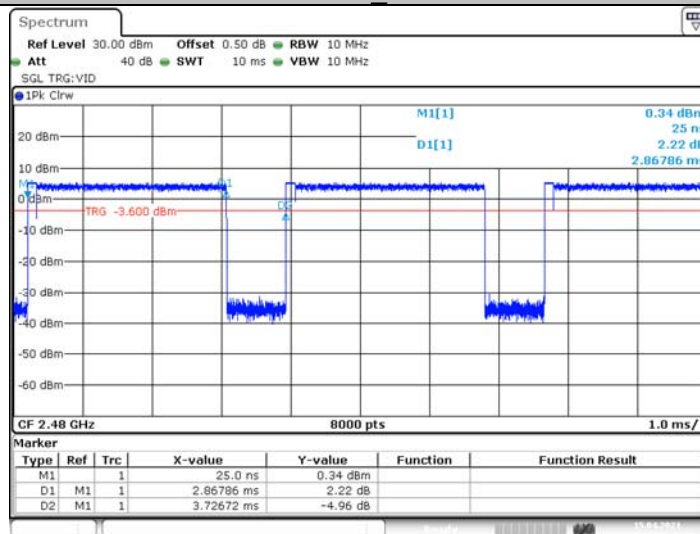

Date: 15.APR.2021 13:36:48





3.11. Antenna requirement

Requirement

FCC CFR Title 47 Part 15 Subpart C Section 15.203:

An intentional radiator shall be designed to ensure that no antenna other than that furnished by the responsible party shall be used with the device. The use of a permanently attached antenna or of antenna that uses a unique coupling to the intentional radiator, the manufacturer may design the unit so that a broken antenna can be replaced by the user, but the use of a standard antenna jack or electrical connector is prohibited.

FCC CFR Title 47 Part 15 Subpart C Section 15.247(c) (1)(i):

(i) Systems operating in the 2400~2483.5 MHz band that is used exclusively for fixed. Point-to-point operations may employ transmitting antennas with directional gain greater than 6dBi provided the maximum conducted output power of the intentional radiator is reduced by 1 dB for every 3 dB that the directional gain of the antenna exceeds 6dBi.

Test Result

The directional gain of the antenna less than 6dBi, please refer to the EUT internal photographs antenna photo.

*****THE END*****