

SmartLink C

Quick Start Guide

Heavy duty / Medium duty / Light duty
Vehicle Communication Interface

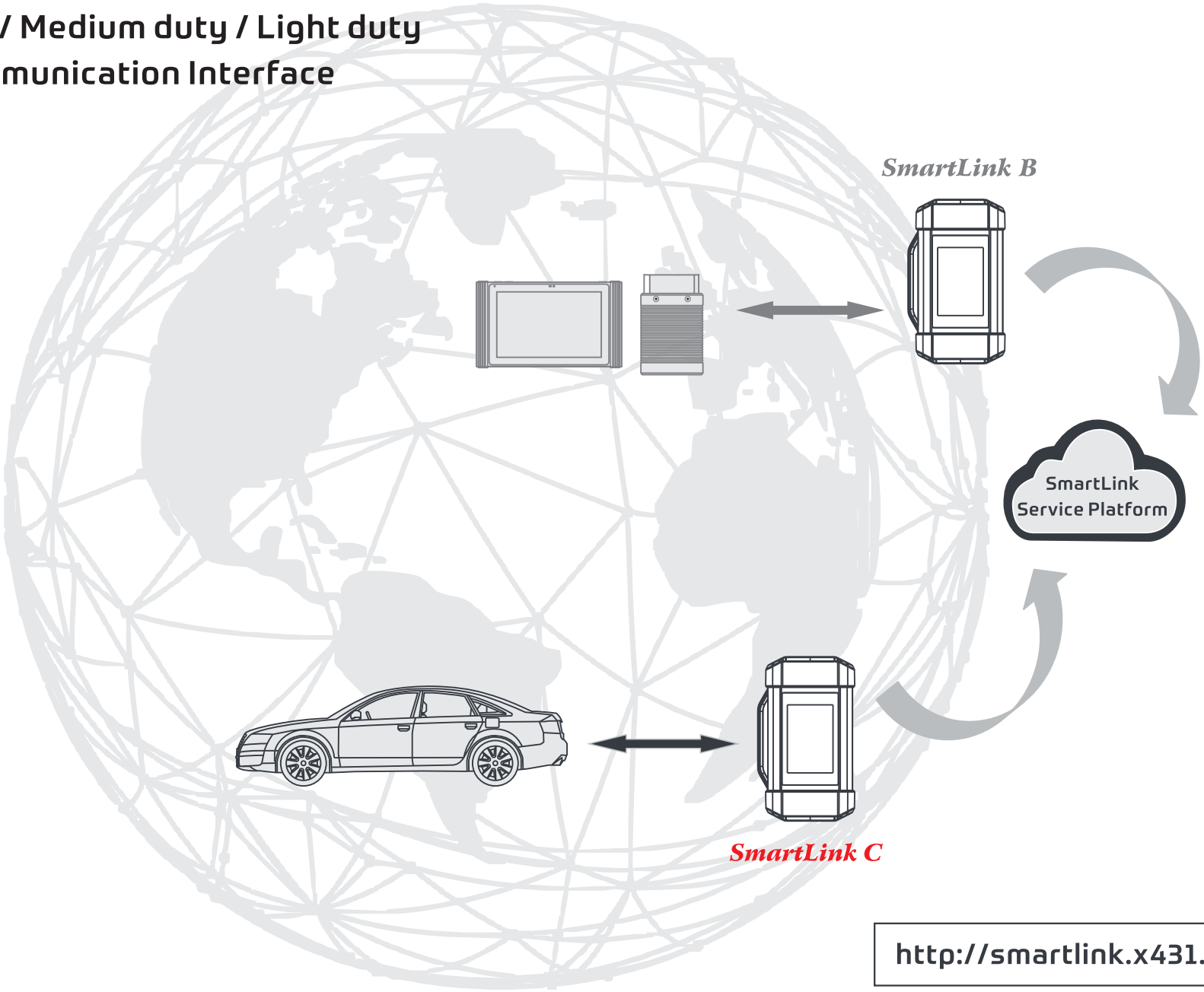

<http://smartlink.x431.com>

Contents

1	Working Principle
2	Controls & Accessories
3	Operations - Register & Post Remote Diagnosis Orders
4	Operations - Start Diagnostics
5	Other Applications
6	FAQ & Appendix

The SmartLink Remote Diagnostics System is a newly developed powerful service system dedicated to remote vehicle diagnosis and service. In this system, SmartLink C user, as a SmartLink Service Subscriber, can submit remote repair orders to vehicle repair companies (SmartLink B, the SmartLink Service Provider) via SmartLink Service Platform (<http://smartlink.x431.com>). The SmartLink C applies to vehicles that comply with CAN/DoIP/CAN FD/J2534 diagnostic protocol standard.

The SmartLink C system consists of the following two parts:

- ✔ **SmartLink Service Platform** -- For binding the SmartLink C dongles and posting the remote repair orders (*Note: Orders can be submitted only after the SmartLink C dongle is successfully bound).
- ✔ **SmartLink C Dongle** -- Connects with vehicle's Data Link Connector (DLC) to obtain vehicle information before submitting repair orders.

The working principle of the SmartLink C dongle is as follows:

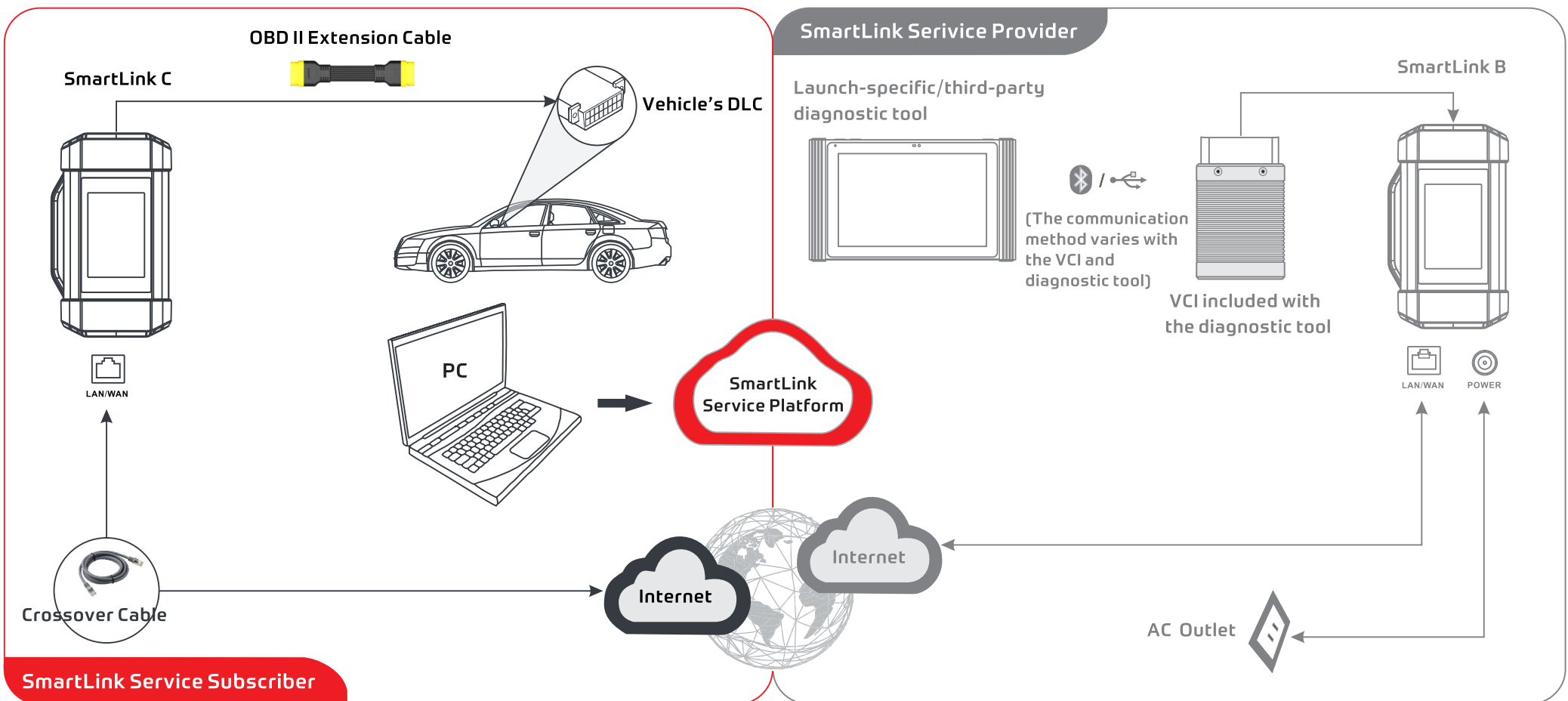

1. Components & Controls

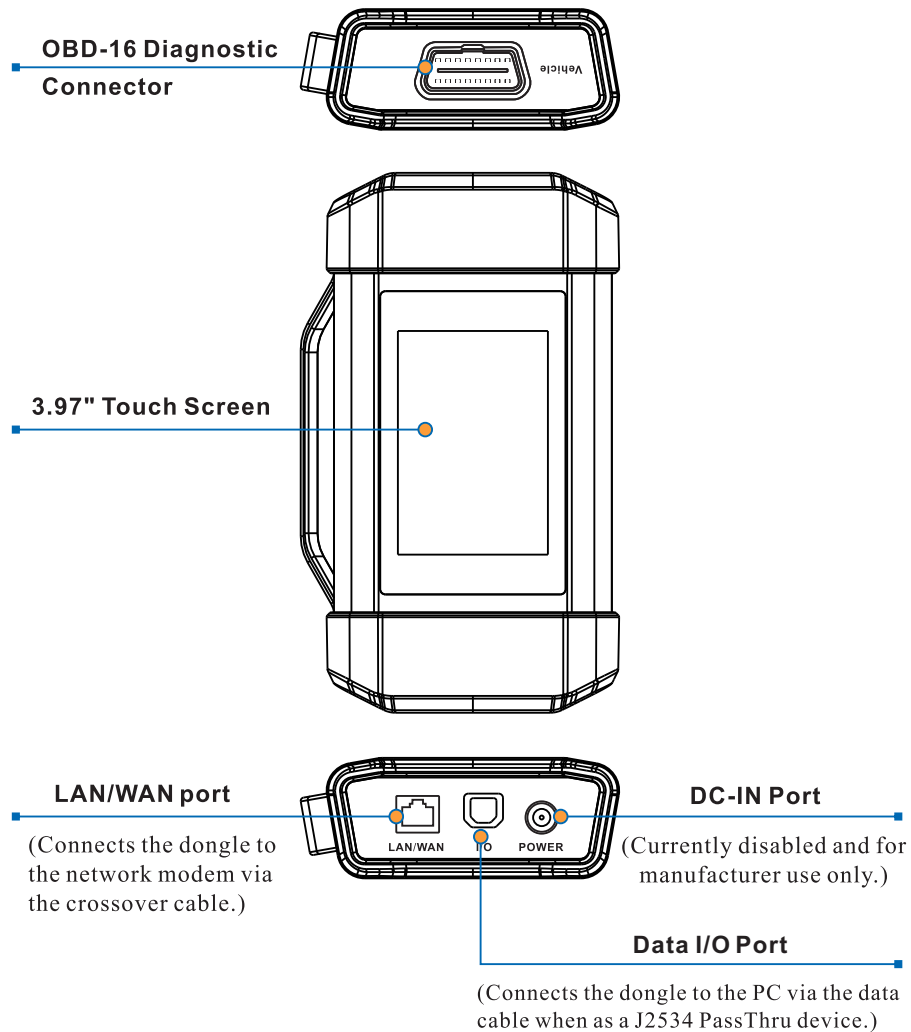

***Warning:** The SmartLink C dongle obtains power through the vehicle's DLC (Data Link Connector), and it is prohibited to connect to an external DC power supply. No responsibility can be assumed for any damage or loss caused as a result of not strictly following the above method.

2. Packing List

The following accessory items are for reference only. For detailed items, please consult from local agency or check the packing list supplied with the device.



SmartLink C Dongle
(For SmartLink Service Subscriber.)



OBD2 Extension Cable
(Connects the dongle to vehicle's DLC port.)



CAT-6 Crossover Cable
(Connects the dongle to the network modem.)



Data Cable
(Connects the dongle to the PC via the data cable when as a J2534 PassThru device.)

*Disclaimer: Due to continuing improvements, actual product may differ slightly from the product described herein.

1. Register & Post remote diagnosis orders

* Due to continuing development and improvements of the SmartLink Service Platform, the user interfaces and functions will be updated periodically. A full version of operation guideline on this platform will be available on the following website <http://smartlink.x431.com>. For more details, please refer to the online Operation Guideline.

- 1 Open a web browser on a tablet or computer, visit the SmartLink Service Platform website <http://smartlink.x431.com>, the following screen will appear. Click **Register now**.

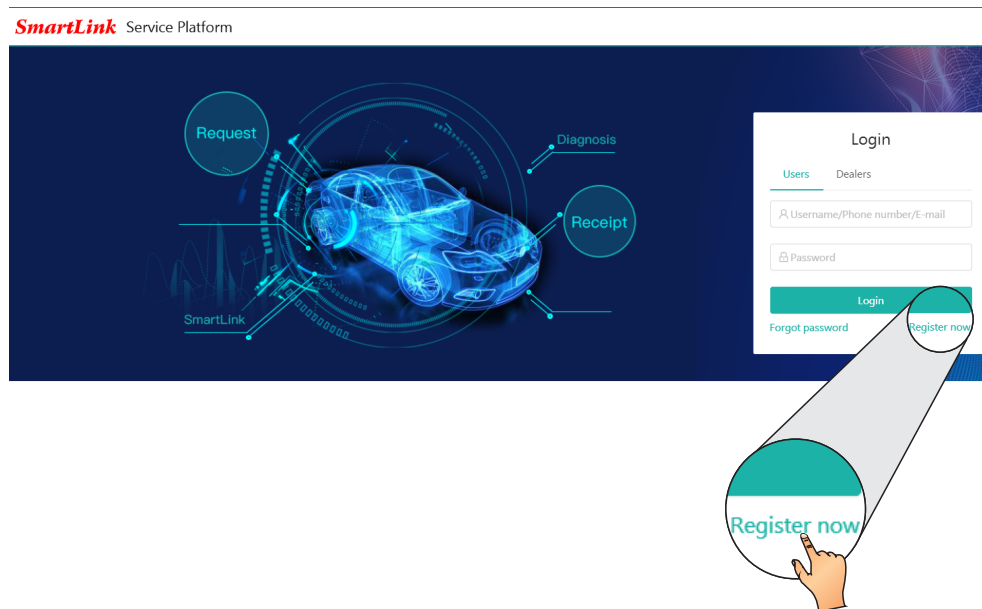

Figure 1 SmartLink Service Platform

2. Start diagnostics

- 2 Input all the required information (where Product Serial Number and Activation Code can be found in the Password Envelope). Select the “I agree” checkbox after reading “Link Platform Register Protocol”, and then click **Register now**.

Figure 2 Registration Page

- 3 After finishing the registration, the system will automatically log in and navigate to the “I’d like a remote assistance” page.

Binding more SmartLink C dongles

To bind more devices to the current account, click **Add a device** in the upper right corner of the screen. Enter your Product Serial Number and Activation Code, and then click **OK**.

- 4 On the “I’d like a remote assistance” page, click **Post Request**. Fill in the required information and then click **Submit**.

* The remote diagnosis can only be performed after the SmartLink C user has submitted the request, and this request has been accepted by the remote technician expert.

1. Register & Post remote diagnosis orders

Operation steps:

1. Turn off the vehicle ignition.
 2. Connect one end of the OBD II extension cable into the OBD-16 diagnostic connector of the Smartlink C dongle, and the other end into the vehicle's DLC port.
- * For more information of DLC location, please refer to the Appendix.

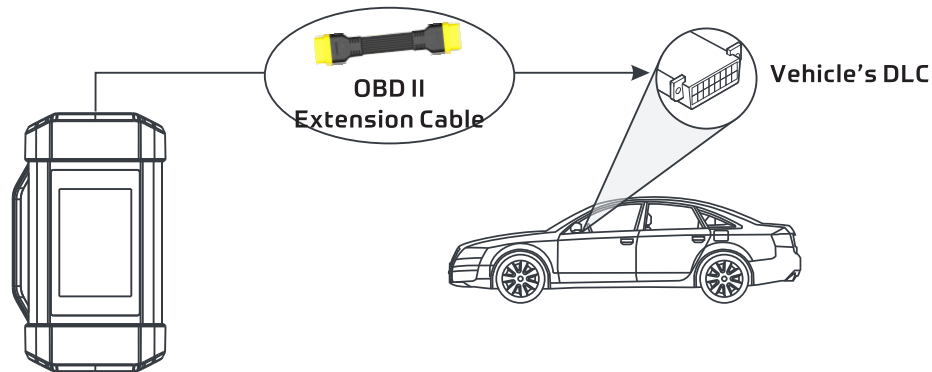

3. Plug one end of CAT-6 crossover cable into the LAN/WLAN port of SmartLink C dongle, and the other end into the LAN port of network modem.

* The network broadband of 100MB and above is required for this operation.

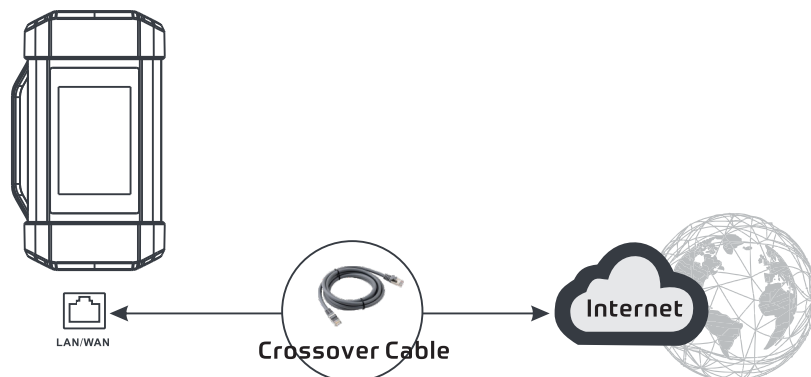

2. Start diagnostics

4. After a successful network connection, the SmartLink C screen displays prompt information asking whether to enter the super remote diagnostic mode. Tap **Yes**, the system will automatically read the vehicle information and connect to the remote diagnosis server.
- * Each SmartLink C dongle can only accept one remote diagnostic operation at one time.
5. Turn on the vehicle ignition.
- * After receiving the order, the SmartLink B master technician will accept the order and contact you via phone or E-mail address. Please make sure that you can be reached via the contact information provided by you.
6. After a successful connection between the SmartLink C and SmartLink B is established, the following message will be displayed on the SmartLink C screen.

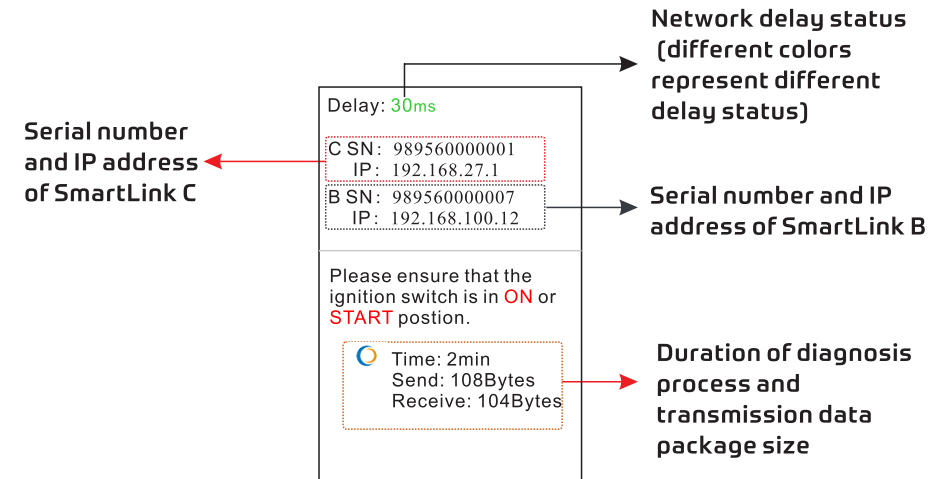

- * Please do not interrupt the vehicle or network connection during a remote diagnostic process.
- * Please make sure that you are well connected with the internet when performing a remote online reprogramming process.
7. Unplug the crossover cable when a diagnostic session is completed.

1. Work as a VCI (Vehicle Communication Interface)

When as a VCI, the SmartLink C dongle needs to work in conjunction with the LAUNCH-specific diagnostic tool, which is used to obtain vehicle data, and then send it to the tool for analysis via WiFi / Bluetooth / data cable.

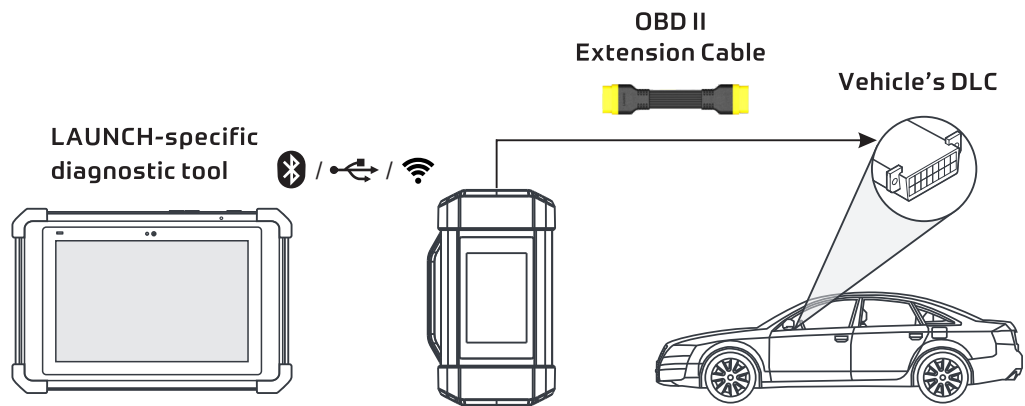

2. Work as Local J2534 PassThru Device

Except that the SmartLink C acts as a VCI device and a SmartLink dongle, it also can be used as a local J2534 PassThru device, working together with the PC installed with the OEM diagnostic software to perform the J2534 reprogramming. In this case, the PC needs to install with the LAUNCH's J2534 tool, which can be downloaded from www.x431.com.

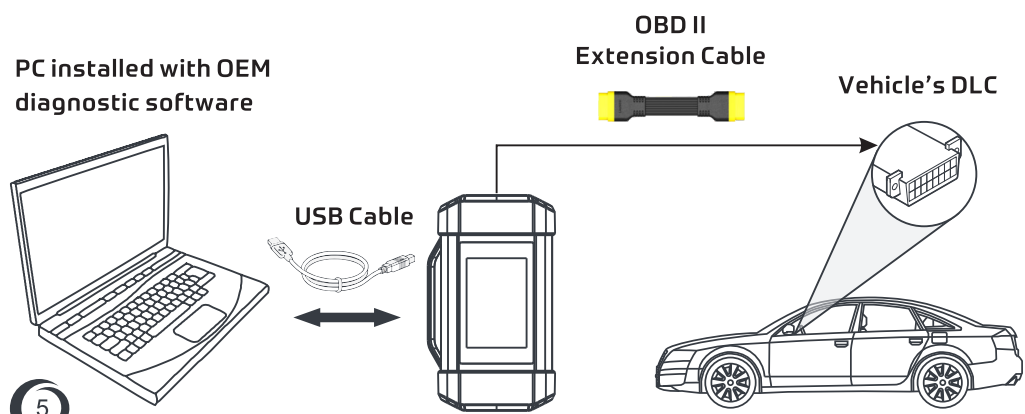

3. Work as Remote J2534 PassThru Device

Additionally, the SmartLink C dongle can also be used as remote J2534 PassThru device while performing remote ECU reprogramming function.

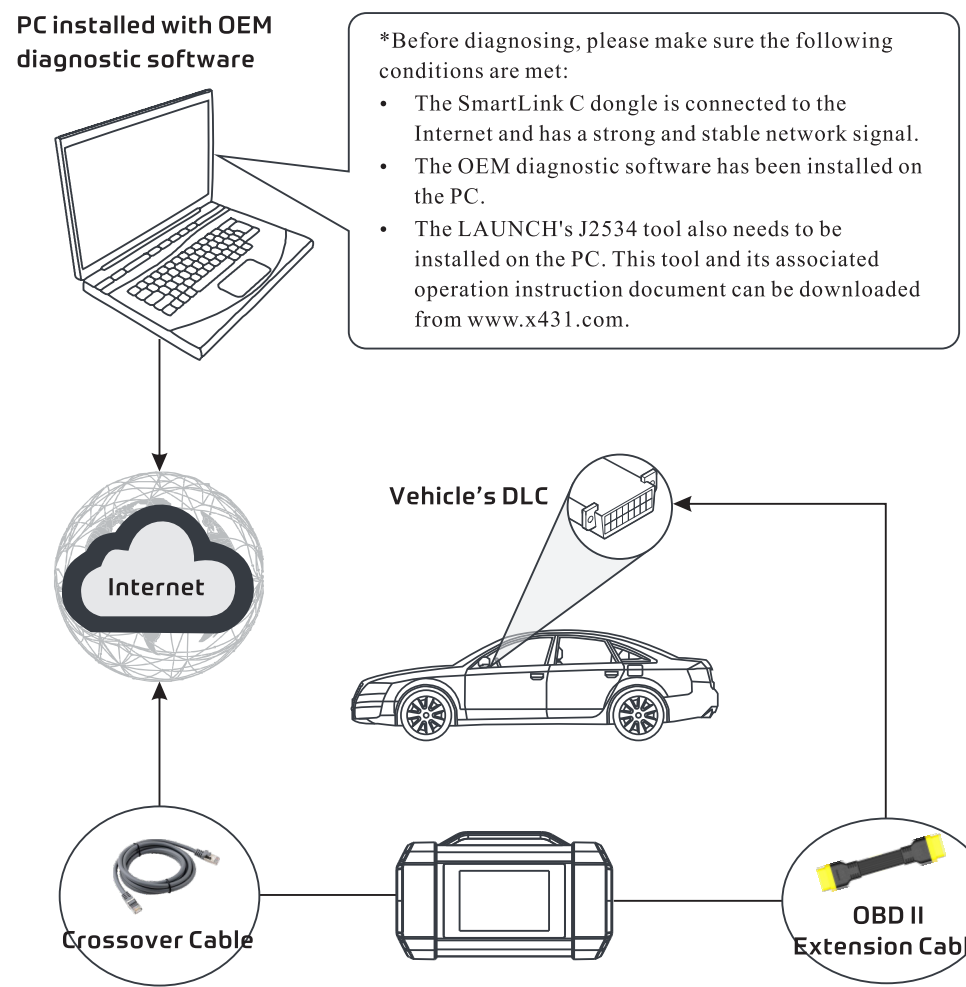

*Before diagnosing, please make sure the following conditions are met:

- The SmartLink C dongle is connected to the Internet and has a strong and stable network signal.
- The OEM diagnostic software has been installed on the PC.
- The LAUNCH's J2534 tool also needs to be installed on the PC. This tool and its associated operation instruction document can be downloaded from www.x431.com.

Ensure that the remote J2534 reprogramming operation is performed after the SmartLink C dongle is connected to the vehicle's DLC port and the Internet, and has been switched to the super remote diagnosis mode. For specific operations, please refer to other associated documents.

1. What's the minimum requirement for network conditions?

The remote SmartLink operation requires a network broadband of 100 MB or above.

2. What does the word "Delay" displayed on the SmartLink C screen mean?

The Delay (network delay) indicates the quality of the current network. Different colors represent different delay status. There are three states of network delay:

- ✔ **Green:** Indicates the network is normal. It is recommended that the diagnosis operation be performed when the network delay is green. Otherwise, the communication with the vehicle may fail or the incorrect system detection may occur.
- ✔ **Yellow:** Indicates the network is not stable. Please keep it stable.
- ✔ **Red:** Indicates the network delay is serious and not suitable for remote diagnosis or the network is disconnected.

3. Why is my network connection so poor?

If the displayed network is poor, there may be too many people using the network in the LAN (Local Area Network) at the same time and some users are downloading. It is recommended to use a stable network for remote SmartLink diagnosis.

4. Why is there a sign in the upper right corner?

Some networks have firewall restriction which leads to a longer delay of connection. You are most likely to see this sign while your system is in connection with networks managed by communities or companies. It is recommended to use the networks directly installed by telecommunication operators where there is no firewall restriction.

5. Some systems of certain old vehicles can not be tested.

The SmartLink C dongle supports CANBUS and DoIP communication protocols, but some old vehicle uses K-Line communication protocol.

6. Is it necessary to re-ignite the car after the diagnostic system starts working?

For the sake of some vehicle's conditions, the re-ignition will provide you a more detailed analysis after OBD diagnosis.

7. Can I use SmartLink C to test heavy-duty vehicles?

Due to vehicle voltage limits, only a few heavy-duty vehicles are supported.

8. Can I charge the SmartLink C dongle through an external DC power supply?

No. The SmartLink C dongle obtains power only through a vehicle's OBD diagnostic socket. Getting power through an external DC power supply could result in system malfunction.

9. Does SmartLink C support Bluetooth communication?

Not yet.

10. How to update SmartLink C system?

After the SmartLink C dongle is powered on and connected to the network, a message "Whether to upgrade now?" will be displayed if a new system version is detected. Tap **Yes** to start updating, wait until the upgrade is complete.

Alternatively, the SmartLink C dongle also can be updated on the PC via LAUNCH'S J2534 tool.

Appendix - DLC Location

The DLC (Data Link Connector) is typically a standard 16-pin connector where diagnostic code readers interface with the vehicle's on-board computer. The DLC is usually located 12 inches from the center of the instrument panel (dash), under or around the driver's side for most vehicles. If DLC is not located under dashboard, a label should be there telling location. For some Asian and European vehicles, the DLC is located behind the ashtray and the ashtray must be removed to access the connector.

If the DLC cannot be found, refer to the vehicle's service manual for the location.

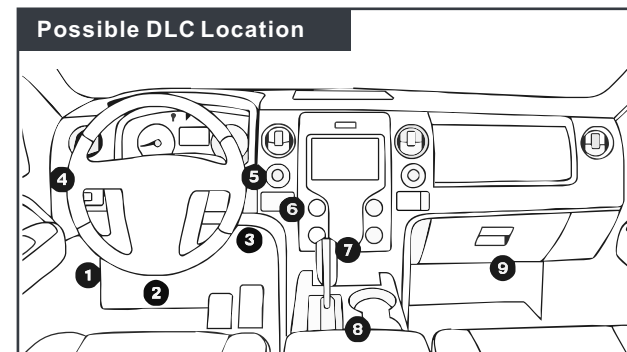

If you have any questions or comments on the operation of the product, please call your local dealer or send Email to our after-sale service email address: overseas.service@cnlaunch.com.



SmartLink C

LAUNCH TECH CO., LTD

Address: Launch Industrial Park, North of Wuhe Rd., Banxuegang,
Longgang, Shenzhen, Guangdong, P.R. China

Post Code: 518129
<http://www.cnlaunch.com>
<http://www.x431.com>

Follow us



Launch Tech HQ



Launch Tech Co., Ltd

Copyright © 2020 by LAUNCH TECH CO., LTD. All rights reserved. No part of this publication or any artwork contained herein may be reproduced in any shape or form without the express written consent of LAUNCH TECH CO., LTD.

Due to continuing improvements, actual product may differ slightly from the product described herein and this publication is subject to change without notice.

封底



封面

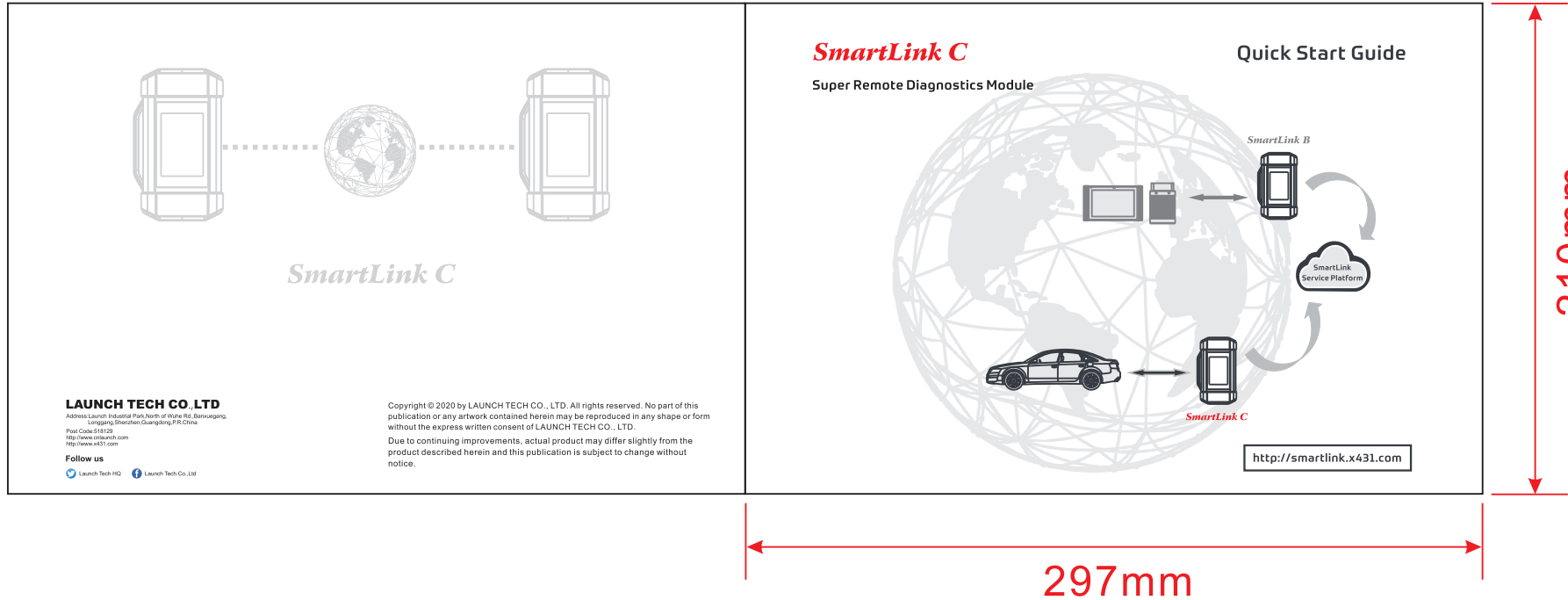

制作要求：

文件大小：A4纸张大小，80g铜版纸

装订方式：骑马钉

印刷方式：黑白印刷

Caution:

This device complies with Part 15 of the FCC rules and Industry Canada license-exempt RSS standard(s). Operation is subject to the following two conditions: (1) this device may not cause harmful interference, and (2) this device must accept any interference received, including interference that may cause undesired operation.

The manufacturer is not responsible for any radio or TV interference caused by unauthorized modifications or change to this equipment. Such modifications or change could void the user's authority to operate the equipment.

This radio transmitter (identify the device by certification number or model number if Category II) has been approved by Industry Canada to operate with the antenna types listed below with the maximum permissible gain indicated. Antenna types not included in this list, having a gain greater than the maximum gain indicated for that type, are strictly prohibited for use with this device.

This equipment has been tested and found to comply with the limits for a Class B digital device, pursuant to part 15 of the FCC Rules. These limits are designed to provide reasonable protection against harmful interference in a residential installation. This equipment generates, uses and can radiate radio frequency energy and, if not installed and used in accordance with the instructions, may cause harmful interference to radio communications. However, there is no guarantee that interference will not occur in a particular installation. If this equipment does cause harmful interference to radio or television reception, which can be determined by turning the equipment off and on, the user is encouraged to try to correct the interference by one or more of the following measures:

- Reorient or relocate the receiving antenna.
- Increase the separation between the equipment and receiver.
- Connect the equipment into an outlet on a circuit different from that to which the receiver is connected.
- Consult the dealer or an experienced radio/TV technician for help.

The device has been evaluated to meet general RF exposure requirement.

To maintain compliance with FCC's RF exposure guidelines, this equipment should be installed and operated with a minimum distance of 20cm between the radiator and your body.

5G

For 5805-5805 frequency band,

Operations in the 5805-5805 band are restricted to indoor usage only.

5G:

Any emission is maintained within the band of operation under all conditions of normal operation. The max. frequency stability is less than 20ppm.