

FCC SAR Test Report

Applicant : Launch Tech Co., Ltd.

Address : Launch Industrial Park, North of Wuhe Rd.,
Banxuegang, Longgang, Shenzhen, 518129,
China

Product Name : Automotive Diagnosis Tool

Report Date : May 17, 2024

Shenzhen Anbotek Compliance Laboratory Limited



Contents

1. Statement of Compliance	6
2. General Information	7
2.1. Client Information	7
2.2. Description of Equipment Under Test (EUT)	7
2.3. Device Category and SAR Limits	9
2.4. Applied Standard	9
2.5. Environment of Test Site	9
2.6. Test Configuration	9
3. Specific Absorption Rate (SAR)	10
3.1. Introduction	10
3.2. SAR Definition	10
4. SAR Measurement System	11
4.1. E-Field Probe	12
4.2. Data Acquisition Electronics (DAE)	12
4.3. Robot	13
4.4. Measurement Server	14
4.5. Phantom	14
4.6. Device Holder	15
4.7. Data Storage and Evaluation	16
5. Test Equipment List	19
6. Tissue Simulating Liquids	20
7. System Verification Procedures	22
8. EUT Testing Position	24
8.1. Body Position	24
8.2. Hotspot Mode Exposure conditions	24
9. Measurement Procedures	25
9.1. Spatial Peak SAR Evaluation	25
9.2. Power Reference Measurement	26
9.3. Area Scan Procedures	26
9.4. Zoom Scan Procedures	27
9.5. Volume Scan Procedures	28
9.6. Power Drift Monitoring	28
10. Conducted Power	29
11. Antenna Location	39
12. SAR Test Results Summary	40
12.1. Body-worn and Hotspot SAR Results	40
13. Simultaneous Transmission Analysis	42
13.1. Simultaneous TX SAR Considerations	42



14. Measurement Uncertainty	43
Appendix A. EUT Photos and Test Setup Photos	45
Appendix B. Plots of SAR System Check	46
Appendix C. Plots of SAR Test Data	50
Appendix D. DASY System Calibration Certificate	60



TEST REPORT

Applicant : Launch Tech Co., Ltd.
Manufacturer : Launch Tech Co., Ltd.
Product Name : Automotive Diagnosis Tool
Model No. : OADD-PD1302A
Reference Model No. : OADD-PD1302x (x=A~Z, indicating configuration difference)
Trade Mark : LAUNCH
Rating(s) : Input: 12V=4A(with DC 7.6V, 9360mAh battery inside)

**Test Standard(s) : IEC/IEEE 62209-1528:2020; FCC 47 CFR Part 2.1093;
IEEE Std C95.1-2019; Reference FCC KDB 447498;
KDB 248227; KDB 616217**

The device described above is tested by Shenzhen Anbotek Compliance Laboratory Limited to determine the maximum emission levels emanating from the device and the severe levels of the device can endure and its performance criterion. The measurement results are contained in this test report and Shenzhen Anbotek Compliance Laboratory Limited is assumed full of responsibility for the accuracy and completeness of these measurements. Also, this report shows that the EUT (Equipment Under Test) is technically compliant with the IEC/IEEE 62209-1528:2020, FCC 47 CFR Part 2.1093, IEEE Std C95.1-2019 requirements.

This report applies to above tested sample only and shall not be reproduced in part without written approval of Shenzhen Anbotek Compliance Laboratory Limited.

Date of Receipt

Mar. 31, 2024

Date of Test

May 13-14, 2024

Prepared By

Ella Liang

(Ella Liang)

Approved & Authorized Signer

Edward Pan

(Edward Pan)



Version

Version No.	Date	Description
R00	May 17, 2024	Original

Note 1:

This is a Class II application which was based on the certified FCC ID: XUJOADDPD1302. The difference between the original device and current one described as following:

1. Change the model name to "OADD-PD1302x (x=A~Z, indicating configuration difference)".
2. Change the Product Name to "Automotive Diagnostic Tool".
3. Change the trade mark to "LAUNCH".
4. Add the adapter with PSY1204000.
5. Change the EUT appearance shape.
6. Remove the LTE part of the motherboard.

The changes are not related with the other RF parameters. According to the difference of appearance shape, and the antenna close to back position. After the SAR test, we found the SAR value of back position is lower than the original. Therefore, SAR in other position does not need to be test.



1. Statement of Compliance

<Highest SAR Summary>

This device is in compliance with Specific Absorption Rate (SAR) for general population/uncontrolled exposure limits (1.6 W/kg) specified in FCC 47 CFR part 2.1093 and IEEE Std C95.1-2019, and had been tested in accordance with the measurement methods and procedures specified in IEC/IEEE 62209-1528:2020.

The maximum results of Specific Absorption Rate (SAR) found during testing are as follows.

<Highest SAR Summary>

The SAR test result of original EUT.

Frequency Band	Highest Reported 1g-SAR(W/Kg)	SAR Test Limit (W/Kg)
	Body-worn(0mm)	
WIFI 2.4G ANT 1	0.662	1.6
WIFI 2.4G ANT 2	0.610	
WIFI 5.2G ANT 1	0.773	
WIFI 5.2G ANT 2	0.594	
WIFI 5.3G ANT 1	0.520	
WIFI 5.3G ANT 2	0.519	
WIFI 5.8G ANT 1	0.750	
WIFI 5.8G ANT 2	0.723	
BT	0.624	
Test Result	PASS	

The back position SAR test results of EUT motherboard changes.

Frequency Band	Highest Reported 1g-SAR(W/Kg)	SAR Test Limit (W/Kg)
	Body-worn (0mm)	
WIFI 2.4G ANT 1	0.622	1.6
WIFI 2.4G ANT 2	0.590	
WIFI 5.2G ANT 1	0.744	
WIFI 5.2G ANT 2	0.584	
WIFI 5.3G ANT 1	0.527	
WIFI 5.3G ANT 2	0.493	
WIFI 5.8G ANT 1	0.738	
WIFI 5.8G ANT 2	0.686	
BT	0.580	
Test Result	PASS	

This device is in compliance with Specific Absorption Rate (SAR) for general population/uncontrolled exposure limits (1.6 W/kg) specified in FCC 47 CFR part 2.1093 and IEEE Std C95.1-2019, and had been tested in accordance with the measurement methods and procedures specified in IEC/IEEE 62209-1528:2020.



2. General Information

2.1. Client Information

Applicant	:	Launch Tech Co., Ltd.
Address	:	Launch Industrial Park, North of Wuhe Rd., Banxuegang, Longgang, Shenzhen, 518129, China
Manufacturer	:	Launch Tech Co., Ltd.
Address	:	Launch Industrial Park, North of Wuhe Rd., Banxuegang, Longgang, Shenzhen, 518129, China
Factory	:	Launch Tech Co., Ltd.
Address	:	Launch Industrial Park, North of Wuhe Rd., Banxuegang, Longgang, Shenzhen, 518129, China

2.2. Description of Equipment Under Test (EUT)

Product Name	:	Automotive Diagnosis Tool
Model No.	:	OADD-PD1302A
Reference Model No.	:	OADD-PD1302x (x=A~Z, indicating configuration difference) (Note: All samples are the same except the model number and appearance color, so we prepare "OADD-PD1302A" for test only.)
Trade Mark	:	LAUNCH
Test Power Supply	:	AC 120V/60Hz for adapter; DC 7.6V battery inside
Test Sample No.	:	1-2-1(Engineering Sample)
Tx Frequency	:	BT: 2402~2480MHz WiFi 2.4G: 2412~2462MHz for 802.11b/g/n(HT20)/ax(HEW20) 2422~2452MHz for 802.11n(HT40)/ax(HEW40) WiFi 5.2G: 5150~5250MHz WiFi 5.3G: 5250~5350MHz WiFi 5.8G: 5725~5850MHz
Type of Modulation	:	BT BDR+EDR: GFSK, $\pi/4$ -DQPSK, 8DPSK BT BLE: GFSK WiFi 2.4G: CCK, DQPSK, DBPSK for DSSS; 64QAM, 16QAM, QPSK, BPSK for OFDM WiFi 5G: OFDM with BPSK, QPSK, 16QAM, 64QAM, 256QAM
Category of device	:	Portable device



Remark:

The above DUT's information was declared by manufacturer. Please refer to the specifications or user's manual for more detailed description.



2.3. Device Category and SAR Limits

This device belongs to portable device category because its radiating structure is allowed to be used within 20 centimeters of the body of the user. Limit for General Population/Uncontrolled exposure should be applied for this device, it is 1.6 W/kg as averaged over any 1 gram of tissue.

2.4. Applied Standard

The Specific Absorption Rate (SAR) testing specification, method, and procedure for this device is in accordance with the following standards:

- IEC/IEEE 62209-1528:2020
- IEEE Std C95.1-2019
- FCC 47 CFR Part 2.1093
- Reference FCC KDB 447498; KDB 248227; KDB 616217

2.5. Environment of Test Site

Items	Required	Actual
Temperature (°C)	18-25	22~23
Humidity (%RH)	30-70	55~65

2.6. Test Configuration

For WIFI and Bluetooth SAR testing, engineering testing software installed on the EUT can provide continuous transmitting RF signal.



3. Specific Absorption Rate (SAR)

3.1. Introduction

SAR is related to the rate at which energy is absorbed per unit mass in an object exposed to a radio field. The SAR distribution in a biological body is complicated and is usually carried out by experimental techniques or numerical modeling. The standard recommends limits for two tiers of groups, occupational/controlled and general population/uncontrolled, based on a person's awareness and ability to exercise control over his or her exposure. In general, occupational/controlled exposure limits are higher than the limits for general population/uncontrolled.

3.2. SAR Definition

The SAR definition is the time derivative (rate) of the incremental energy (dW) absorbed by (dissipated in) an incremental mass (dm) contained in a volume element (dv) of a given density (ρ). The equation description is as below:

$$SAR = \frac{d}{dt} \left(\frac{dW}{dm} \right) = \frac{d}{dt} \left(\frac{dW}{\rho dv} \right)$$

SAR is expressed in units of Watts per kilogram (W/kg)

SAR measurement can be either related to the temperature elevation in tissue by

$$SAR = c \left(\frac{\delta T}{\delta t} \right)$$

Where: C is the specific heat capacity, δT is the temperature rise and δt is the exposure duration, or related to the electrical field in the tissue by

$$SAR = \frac{\sigma |E|^2}{\rho}$$

Where: σ is the conductivity of the tissue, ρ is the mass density of the tissue and E is the RMS electrical field strength.

However for evaluating SAR of low power transmitter, electrical field measurement is typically applied.



4. SAR Measurement System

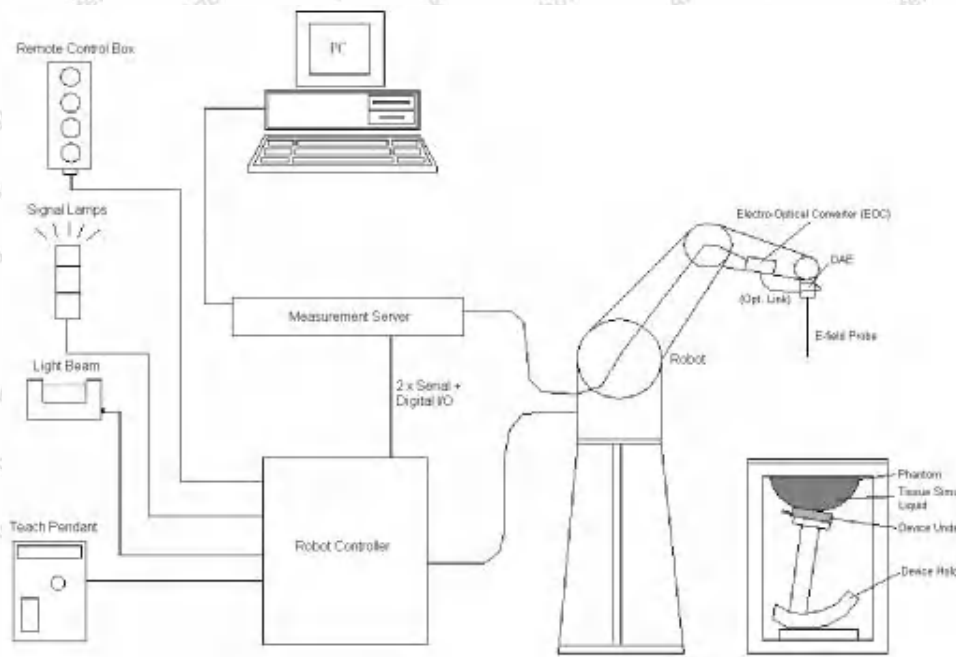

DASy System Configurations

The DASy system for performance compliance tests is illustrated above graphically. This system consists of the following items:

- A standard high precision 6-axis robot with controller, a teach pendant and software
- A data acquisition electronic (DAE) attached to the robot arm extension
- A dosimetric probe equipped with an optical surface detector system
- The electro-optical converter (EOC) performs the conversion between optical and electrical signals
- A measurement server performs the time critical tasks such as signal filtering, control of the robot operation and fast movement interrupts.
- A probe alignment unit which improves the accuracy of the probe positioning
- A computer operating Windows XP
- DASy software
- Remote control with teach pendant and additional circuitry for robot safety such as warning lamps, etc.
- The SAM twin phantom
- A device holder
- Tissue simulating liquid
- Dipole for evaluating the proper functioning of the system

components are described in details in the following sub-sections.



4.1.E-Field Probe

The SAR measurement is conducted with the dosimetric probe (manufactured by SPEAG).The probe is specially designed and calibrated for use in liquid with high permittivity. The dosimetric probe has special calibration in liquid at different frequency. This probe has a built in optical surface detection system to prevent from collision with phantom.

➤ E-Field Probe Specification

<EX3DV4 Probe>

Construction	Symmetrical design with triangular core Built-in shielding against static charges PEEK enclosure material (resistant to organic solvents, e.g., DGBE)	 <p>Photo of EX3DV4</p>
Frequency	10 MHz to 6 GHz; Linearity: ± 0.2 dB	
Directivity	± 0.3 dB in HSL (rotation around probe axis) ± 0.5 dB in tissue material (rotation normal to probe axis)	
Dynamic Range	10 μ W/g to 100 W/kg; Linearity: ± 0.2 dB (noise: typically < 1 μ W/g)	
Dimensions	Overall length: 330 mm (Tip: 20 mm) Tip diameter: 2.5 mm (Body: 12 mm) Typical distance from probe tip to dipole centers: 1 mm	

➤ E-Field Probe Calibration

Each probe needs to be calibrated according to a dosimetric assessment procedure with accuracy better than $\pm 10\%$. The spherical isotropy shall be evaluated and within ± 0.25 dB. The sensitivity parameters (NormX, NormY, and NormZ), the diode compression parameter (DCP) and the conversion factor (ConvF) of the probe are tested. The calibration data can be referred to appendix C of this report.

4.2.Data Acquisition Electronics (DAE)

The data acquisition electronics (DAE) consists of a highly sensitive electrometer-grade preamplifier with auto-zeroing, a channel and gain-switching multiplexer, a fast 16 bit AD-converter and a command decoder and control logic unit. Transmission to the measurement server is accomplished through an optical downlink for data and status information as well as an optical uplink for commands and the clock.

The input impedance of the DAE is 200MOhm; the inputs are symmetrical and floating. Common



Report No.: 18220WC40058505
mode rejection is above 80dB.

FCC ID: XUJOADDPD1302

Page 13 of 101



Photo of DAE

4.3.Robot

The SPEAG DASY system uses the high precision robots (DASY5: TX60XL) type from Stäubli SA (France). For the 6-axis controllersystem, the robot controller version (DASY5: CS8c) from Stäubli is used. The Stäublirobot series have many features that are important for our application:

- High precision (repeatability ± 0.035 mm)
- High reliability (industrial design)
- Jerk-free straight movements
- Low ELF interference (the closed metallic construction shields against motor control fields)



Photo of DASY5



4.4. Measurement Server

The measurement server is based on a PC/104 CPU board with CPU (DASY5: 400 MHz, Intel Celeron), chipdisk (DASY5: 128 MB), RAM (DASY5: 128 MB). The necessary circuits for communication with the DAE electronic box, as well as the 16 bit AD converter system for optical detection and digital I/O interface are contained on the DASY I/O board, which is directly connected to the PC/104 bus of the CPU board.

The measurement server performs all the real-time data evaluation for field measurements and surface detection, controls robot movements and handles safety operations.



Photo of Server for DASY5

4.5. Phantom

<SAM Twin Phantom>

Shell Thickness	2 ± 0.2 mm; Center ear point: 6 ± 0.2 mm	
Filling Volume	Approx. 25 liters	
Dimensions	Length: 1000 mm; Width: 500 mm; Height: adjustable feet	
Measurement Areas	Left Hand, Right Hand, Flat Phantom	

The bottom plate contains three pair of bolts for locking the device holder. The device holder positions are adjusted to the standard measurement positions in the three sections. A white cover is provided to tap the phantom during off-periods to prevent water evaporation and changes in the liquid parameters. On the phantom top, three reference markers are provided to identify the phantom position with respect to the robot.

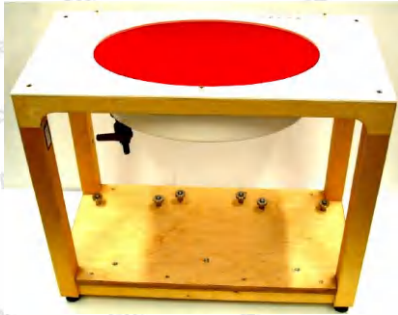

<ELI4 Phantom>

Shell Thickness	2 ± 0.2 mm (sagging: <1%)	 <p>Photo of ELI4 Phantom</p>
Filling Volume	Approx. 30 liters	
Dimensions	Major ellipse axis: 600 mm Minor axis: 400 mm	

The ELI4 phantom is intended for compliance testing of handheld and body-mounted wireless devices in the frequency range of 30 MHz to 6 GHz. ELI4 is fully compatible with standard and all known tissue simulating liquids.

4.6. Device Holder

The SAR in the phantom is approximately inversely proportional to the square of the distance between the source and the liquid surface. For a source at 5 mm distance, a positioning uncertainty of ±0.5mm would produce a SAR uncertainty of ± 20%. Accurate device positioning is therefore crucial for accurate and repeatable measurements. The positions in which the devices must be measured are defined by the standards.

The DASY device holder is designed to cope with different positions given in the standard. It has two scales for the device rotation (with respect to the body axis) and the device inclination (with respect to the line between the ear reference points). The rotation center for both scales is the ear reference point (ERP). Thus the device needs no repositioning when changing the angles.

The DASY device holder is constructed of low-loss POM material having the following dielectric parameters: relative permittivity $\epsilon = 3$ and loss tangent $\delta = 0.02$. The amount of dielectric material has been reduced in the closest vicinity of the device, since measurements have suggested that the influence of the clamp on the test results could thus be lowered.



**Device Holder**

4.7. Data Storage and Evaluation

➤ Data Storage

The DASY software stores the assessed data from the data acquisition electronics as raw data (in microvolt readings from the probe sensors), together with all the necessary software parameters for the data evaluation (probe calibration data, liquid parameters and device frequency and modulation data) in measurement files. The post-processing software evaluates the desired unit and format for output each time the data is visualized or exported. This allows verification of the complete software setup even after the measurement and allows correction of erroneous parameter settings. For example, if a measurement has been performed with an incorrect crest factor parameter in the device setup, the parameter can be corrected afterwards and the data can be reevaluated.

The measured data can be visualized or exported in different units or formats, depending on the selected probe type (e.g., [V/m], [A/m], [W/kg]). Some of these units are not available in certain situations or give meaningless results, e.g., a SAR-output in a non-lose media, will always be zero. Raw data can also be exported to perform the evaluation with other software packages.

➤ Data Evaluation

The DASY post-processing software (SEMCAD) automatically executes the following procedures to calculate the field units from the microvolt readings at the probe connector. The



Report No.: 18220WC40058505 FCC ID: XUJOADDPD1302 Page 17 of 101
 parameters used in the evaluation are stored in the configuration modules of the software:

Probe parameters:	- Sensitivity	Norm _i , a _{i0} , a _{i1} , a _{i2}
	- Conversion factor	ConvF _i
	- Diode compression point	dcp _i
Device parameters:	- Frequency	f
	- Crest factor	cf
Media parameters:	- Conductivity	σ
	- Density	ρ

These parameters must be set correctly in the software. They can be found in the component documents or they can be imported into the software from the configuration files issued for the DASYS components. In the direct measuring mode of the multi-meter option, the parameters of the actual system setup are used. In the scan visualization and export modes, the parameters stored in the corresponding document files are used.

The first step of the evaluation is a linearization of the filtered input signal to account for the compression characteristics of the detector diode. The compensation depends on the input signal, the diode type and the DC-transmission factor from the diode to the evaluation electronics. If the exciting field is pulsed, the crest factor of the signal must be known to correctly compensate for peak power.

The formula for each channel can be given as:

$$V_i = U_i + U_i^2 \cdot \frac{cf}{dcp_i}$$

with V_i = compensated signal of channel i , ($i = x, y, z$)

U_i = input signal of channel i , ($i = x, y, z$)

cf = crest factor of exciting field (DASY parameter)

dcp_i = diode compression point (DASY parameter)

From the compensated input signals, the primary field data for each channel can be evaluated:

$$\text{E-field Probes: } E_i = \sqrt{\frac{V_i}{\text{Norm}_i \cdot \text{ConvF}}}$$

$$\text{H-field Probes: } H_i = \sqrt{V_i} \cdot \frac{a_{i0} + a_{i1}f + a_{i2}f^2}{f}$$

with V_i = compensated signal of channel i , ($i = x, y, z$)

Norm_i = sensor sensitivity of channel i , ($i = x, y, z$), $\mu\text{V}/(\text{V}/\text{m})^2$ for E-field Probes

ConvF = sensitivity enhancement in solution

a_{ij} = sensor sensitivity factors for H-field probes

f = carrier frequency [GHz]



E_i = electric field strength of channel i in V/m

H_i = magnetic field strength of channel i in A/m

The RSS value of the field components gives the total field strength (Hermitian magnitude):

$$E_{\text{tot}} = \sqrt{E_x^2 + E_y^2 + E_z^2}$$

The primary field data are used to calculate the derived field units.

$$\text{SAR} = E_{\text{tot}}^2 \cdot \frac{\sigma}{\rho \cdot 1000}$$

with SAR = local specific absorption rate in W/kg

E_{tot} = total field strength in V/m

σ = conductivity in [mho/m] or [Siemens/m]

ρ = equivalent tissue density in g/cm³

Note that the density is set to 1, to account for actual head tissue density rather than the density of the tissue simulating liquid.



5. Test Equipment List

Manufacturer	Name of Equipment	Type/Model	Serial Number	Calibration	
				Last Cal.	Due Date
SPEAG	2450MHz System Validation Kit	D2450V2	910	Jun. 15,2021	Jun. 14,2024
SPEAG	5GHz System Validation Kit	D5GHzV2	1160	Oct. 02, 2021	Oct. 01, 2024
Rohde & Schwarz	UNIVERSAL RADIO COMMUNICATION TESTER	CMW500	1201.0002K50-104209-JC	Nov.10, 2023	Nov.09, 2024
SPEAG	Data Acquisition Electronics	DAE4	387	Sept.06,2023	Sept.05,2024
SPEAG	Dosimetric E-Field Probe	EX3DV4	7396	May 06,2024	May 05,2025
Agilent	ENA Series Network Analyzer	E5071C	MY46317418	Oct.26, 2023	Oct.25, 2024
SPEAG	DAK	DAK-3.5	1226	NCR	NCR
SPEAG	SAM Twin Phantom	QD000P40CD	1802	NCR	NCR
SPEAG	ELI Phantom	QDOVA004A A	2058	NCR	NCR
AR	Amplifier	ZHL-42W	QA1118004	NCR	NCR
Agilent	Power Meter	N1914A	MY50001102	Oct.26, 2023	Oct.25, 2024
Agilent	Power Sensor	N8481H	MY51240001	Oct.26, 2023	Oct.25, 2024
R&S	Spectrum Analyzer	N9020A	MY51170037	Oct.26, 2023	Oct.25, 2024
Agilent	Signal Generation	N5182A	MY48180656	Oct.26, 2023	Oct.25, 2024
Worken	Directional Coupler	0110A05601O -10	COM5BNW1A2	Oct.26, 2023	Oct.25, 2024

Note:

1. The calibration certificate of DASY can be referred to appendix C of this report.
2. The dipole calibration interval can be extended to 3 years with justification. The dipoles are also not physically damaged, or repaired during the interval.
3. The Insertion Loss calibration of Dual Directional Coupler and Attenuator were characterized via the network analyzer and compensated during system check.
4. The dielectric probe kit was calibrated via the network analyzer, with the specified procedure (calibrated in pure water) and calibration kit (standard) short circuit, before the dielectric measurement. The specific procedure and calibration kit are provided by Agilent.
5. In system check we need to monitor the level on the power meter, and adjust the power amplifier level to have precise power level to the dipole; the measured SAR will be normalized to 1W input power according to the ratio of 1W to the input power to the dipole. For system check, the calibration of the power amplifier is deemed not critically required for correct measurement; the power meter is critical and we do have calibration for it



6. Tissue Simulating Liquids

For the measurement of the field distribution inside the SAM phantom with DASy, the phantom must be filled with around 25 liters of homogeneous body tissue simulating liquid. For head SAR testing, the liquid height from the ear reference point (ERP) of the phantom to the liquid top surface is larger than 15 cm, which is shown in Fig. 6.1. For body SAR testing, the liquid height from the center of the flat phantom to the liquid top surface is larger than 15 cm, which is shown as followed:



Photo of Liquid Height for Body SAR

The following table gives the recipes for tissue simulating liquid.

Frequency (MHz)	Water (%)	Sugar (%)	Cellulose (%)	Salt (%)	Preventol (%)	DGBE (%)	Conductivity (σ)	Permittivity (ϵ_r)
For Body								
2450	68.6	0	0	0	0	31.4	1.95	52.7
5200	78.6	0	10.7	0	10.7	0	5.27	49.0
5300	78.4	0	10.7	0	10.9	0	5.52	48.74
5800	78.5	0	10.8	0	10.7	0	6.00	48.2



The following table shows the measuring results for simulating liquid.

Measured Frequency (MHz)	Target Tissue		Measured Tissue				Liquid Temp.	Test Data
	ϵ_r	σ	ϵ_r	Dev. (%)	σ	Dev. (%)		
2450	39.2	1.80	39.08	-0.31	1.85	2.78	22.7	05/13/2024
5200	36.0	4.66	36.21	0.58	4.71	1.07	22.5	05/14/2024
5300	35.9	4.76	35.56	-0.95	4.83	1.47	22.5	05/14/2024
5800	48.20	6.00	48.45	0.52	5.85	-2.56	22.4	05/14/2024



7. System Verification Procedures

Each DASY system is equipped with one or more system validation kits. These units, together with the predefined measurement procedures within the DASY software, enable the user to conduct the system performance check and system validation. System validation kit includes a dipole, tripod holder to fix it underneath the flat phantom and a corresponding distance holder.

➤ Purpose of System Performance check

The system performance check verifies that the system operates within its specifications. System and operator errors can be detected and corrected. It is recommended that the system performance check be performed prior to any usage of the system in order to guarantee reproducible results. The system performance check uses normal SAR measurements in a simplified setup with a well characterized source. This setup was selected to give a high sensitivity to all parameters that might fail or vary over time. The system check does not intend to replace the calibration of the components, but indicates situations where the system uncertainty is exceeded due to drift or failure.

➤ System Setup

In the simplified setup for system evaluation, the EUT is replaced by a calibrated dipole and the power source is replaced by a continuous wave that comes from a signal generator. The calibrated dipole must be placed beneath the flat phantom section of the SAM twin phantom with the correct distance holder. The distance holder should touch the phantom surface with a light pressure at the reference marking and be oriented parallel to the long side of the phantom. The equipment setup is shown below:

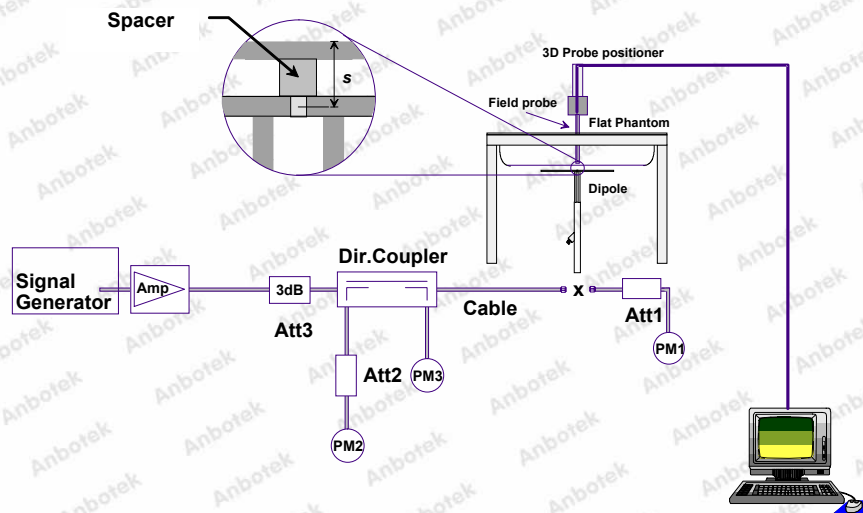

System Setup for System Evaluation



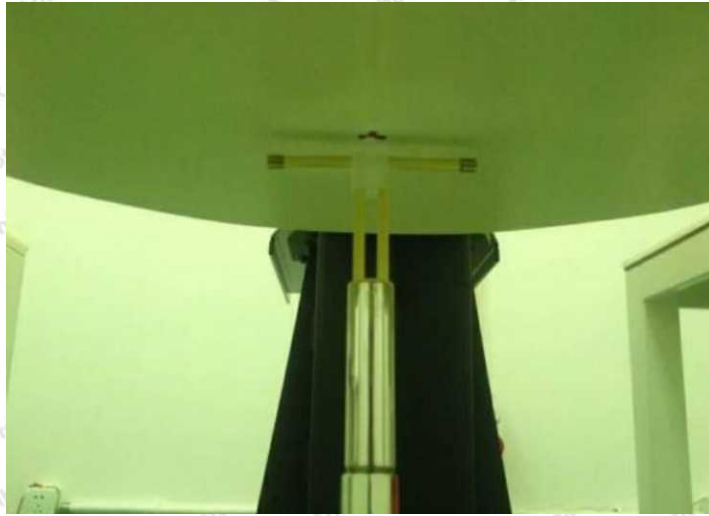

Photo of Dipole Setup

➤ Validation Results

Comparing to the original SAR value provided by SPEAG, the verification data should be within its specification of 10%. The table below shows the target SAR and measured SAR after normalized to 1W input power. It indicates that the system performance check can meet the variation criterion and the plots can be referred to Appendix A of this report.

Date	Frequency (MHz)	Power fed onto reference dipole (mW)	Targeted SAR (W/kg)	Measured SAR (W/kg)	Normalized SAR (W/kg)	Deviation (%)
05/13/2024	2450	250	52.4	12.95	51.8	-1.15
05/14/2024	5200	100	80.7	7.97	79.7	-1.24
05/14/2024	5300	100	82.7	8.04	80.4	-2.78
05/14/2024	5800	100	78.3	7.99	79.50	1.53

Target and Measurement SAR after Normalized



8. EUT Testing Position

8.1. Body Position

Devices that support transmission while used with body-worn accessories must be tested for body-worn accessory SAR compliance, typically according to the smallest test separation distance required for the group of body-worn accessories with similar operating and exposure characteristics.

Devices that are designed to operate on the body of users using lanyards and straps or without requiring additional body-worn accessories must be tested for SAR compliance using a conservative minimum test separation distance $\leq 5\text{mm}$ to support compliance.

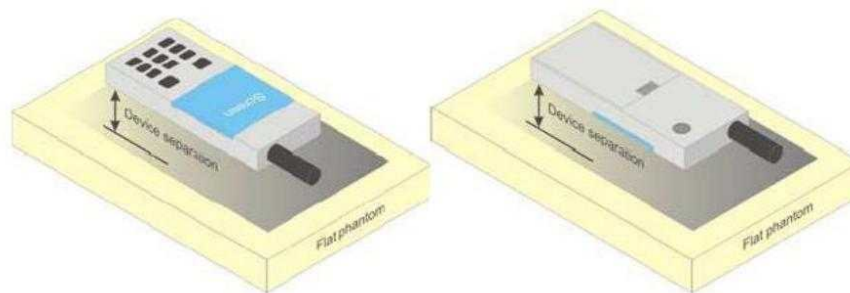

Picture 4 Test positions for body-worn devices

8.2. Hotspot Mode Exposure conditions

The hotspot mode and body-worn accessory SAR test configurations may overlap for handsets. When the same wireless mode transmission configurations for voice and data are required for SAR measurements, the more conservative configuration with a smaller separation distance should be tested for the overlapping SAR configurations. This typically applies to the back and front surfaces of a handset when SAR is required for both hotspot mode and body-worn accessory exposure conditions. Depending on the form factor and dimensions of a device, the test separation distance used for hotspot mode SAR measurement is either

10 mm or that used in the body-worn accessory configuration, whichever is less for devices with dimension $> 9\text{ cm} \times 5\text{ cm}$. For smaller devices with dimensions $\leq 9\text{ cm} \times 5\text{ cm}$ because of a greater potential for next to body use a test separation of $\leq 5\text{ mm}$ must be used.

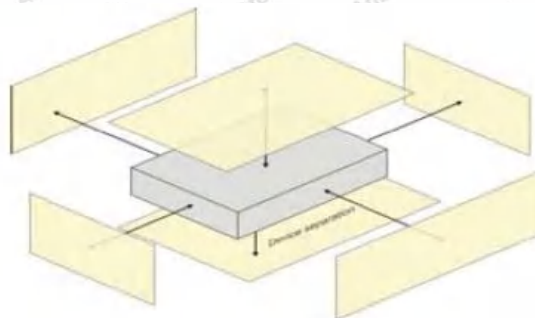

Picture 5 Test positions for Hotspot Mode



9. Measurement Procedures

The measurement procedures are as follows:

- (a) Use base station simulator (if applicable) or engineering software to transmit RF power continuously (continuous Tx) in the middle channel.
- (b) Keep EUT to radiate maximum output power or 100% duty factor (if applicable)
- (c) Measure output power through RF cable and power meter.
- (d) Place the EUT in the positions as setup photos demonstrates.
- (e) Set scan area, grid size and other setting on the DASY software.
- (f) Measure SAR transmitting at the middle channel for all applicable exposure positions.
- (g) Identify the exposure position and device configuration resulting the highest SAR
- (h) Measure SAR at the lowest and highest channels at the worst exposure position and device configuration if applicable.

According to the test standard, the recommended procedure for assessing the peak spatial-average SAR value consists of the following steps:

- (a) Power reference measurement
- (b) Area scan
- (c) Zoom scan
- (d) Power drift measurement

9.1. Spatial Peak SAR Evaluation

The procedure for spatial peak SAR evaluation has been implemented according to the test standard. It can be conducted for 1g and 10g, as well as for user-specific masses. The DASY software includes all numerical procedures necessary to evaluate the spatial peak SAR value.

The base for the evaluation is a "cube" measurement. The measured volume must include the 1g and 10g cubes with the highest averaged SAR values. For that purpose, the center of the measured volume is aligned to the interpolated peak SAR value of a previously performed area scan.

The entire evaluation of the spatial peak values is performed within the post-processing engine (SEMCAD). The system always gives the maximum values for the 1g and 10g cubes. The algorithm to find the cube with highest averaged SAR is divided into the following stages:

- (a) Extraction of the measured data (grid and values) from the Zoom Scan
- (b) Calculation of the SAR value at every measurement point based on all stored data (A/D values and measurement parameters)
- (c) Generation of a high-resolution mesh within the measured volume
- (d) Interpolation of all measured values from the measurement grid to the high-resolution grid
- (e) Extrapolation of the entire 3-D field distribution to the phantom surface over the distance from sensor to surface
- (f) Calculation of the averaged SAR within masses of 1g and 10g



9.2. Power Reference Measurement

The Power Reference Measurement and Power Drift Measurements are for monitoring the power drift of the device under test in the batch process. The minimum distance of probe sensors to surface determines the closest measurement point to phantom surface. This distance cannot be smaller than the distance of sensor calibration points to probe tip as defined in the probe properties.

9.3. Area Scan Procedures

The area scan is used as a fast scan in two dimensions to find the area of high field values, before doing a fine measurement around the hot spot. The sophisticated interpolation routines implemented in DASY software can find the maximum found in the scanned area, within a range of the global maximum. The range (in dB0) is specified in the standards for compliance testing. For example, a 2 dB range is required in IEEE standard 1528 and IEC 62209 standards, whereby 3 dB is a requirement when compliance is assessed in accordance with the ARIB standard (Japan), if only one zoom scan follows the area scan, then only the absolute maximum will be taken as reference. For cases where multiple maximums are detected, the number of zoom scans has to be increased accordingly.

Area scan parameters extracted from FCC KDB 865664 D01 SAR measurement 100 MHz to 6 GHz.

	≤ 3 GHz	> 3 GHz
Maximum distance from closest measurement point (geometric center of probe sensors) to phantom surface	5 ± 1 mm	$\frac{1}{2} \cdot \delta \cdot \ln(2) \pm 0.5$ mm
Maximum probe angle from probe axis to phantom surface normal at the measurement location	30° ± 1°	20° ± 1°
Maximum area scan spatial resolution: Δx_{Area} , Δy_{Area}	≤ 2 GHz: ≤ 15 mm 2 – 3 GHz: ≤ 12 mm	3 – 4 GHz: ≤ 12 mm 4 – 6 GHz: ≤ 10 mm
	When the x or y dimension of the test device, in the measurement plane orientation, is smaller than the above, the measurement resolution must be ≤ the corresponding x or y dimension of the test device with at least one measurement point on the test device.	



9.4.Zoom Scan Procedures

Zoom scans are used assess the peak spatial SAR values within a cubic averaging volume containing 1 gram and 10gram of simulated tissue. The zoom scan measures points (refer to table below) within a cube shoes base faces are centered on the maxima found in a preceding area scan job within the same procedure. When the measurement is done, the zoom scan evaluates the averaged SAR for 1 gram and 10 gram and displays these values next to the job's label.

Zoom scan parameters extracted from FCC KDB 865664 D01 SAR measurement 100 MHz to 6 GHz.

		≤ 3 GHz	> 3 GHz	
Maximum zoom scan spatial resolution: $\Delta x_{Zoom}, \Delta y_{Zoom}$		≤ 2 GHz: ≤ 8 mm $2 - 3$ GHz: ≤ 5 mm*	$3 - 4$ GHz: ≤ 5 mm* $4 - 6$ GHz: ≤ 4 mm*	
Maximum zoom scan spatial resolution, normal to phantom surface	uniform grid: $\Delta z_{Zoom}(n)$	≤ 5 mm	$3 - 4$ GHz: ≤ 4 mm $4 - 5$ GHz: ≤ 3 mm $5 - 6$ GHz: ≤ 2 mm	
	graded grid	$\Delta z_{Zoom}(1)$: between 1 st two points closest to phantom surface	≤ 4 mm	$3 - 4$ GHz: ≤ 3 mm $4 - 5$ GHz: ≤ 2.5 mm $5 - 6$ GHz: ≤ 2 mm
		$\Delta z_{Zoom}(n>1)$: between subsequent points	$\leq 1.5 \cdot \Delta z_{Zoom}(n-1)$	
Minimum zoom scan volume	x, y, z	≥ 30 mm	$3 - 4$ GHz: ≥ 28 mm $4 - 5$ GHz: ≥ 25 mm $5 - 6$ GHz: ≥ 22 mm	

Note: δ is the penetration depth of a plane-wave at normal incidence to the tissue medium: see draft standard IEEE P1528-2011 for details.

* When zoom scan is required and the reported SAR from the area scan based 1-g SAR estimation procedures of KDB 447498 is ≤ 1.4 W/kg, ≤ 8 mm, ≤ 7 mm and ≤ 5 mm zoom scan resolution may be applied, respectively, for 2 GHz to 3 GHz, 3 GHz to 4 GHz and 4 GHz to 6 GHz.



9.5. Volume Scan Procedures

The volume scan is used for assess overlapping SAR distributions for antennas transmitting in different frequency bands. It is equivalent to an oversized zoom scan used in standalone measurements. The measurement volume will be used to enclose all the simultaneous transmitting antennas. For antennas transmitting simultaneously in different frequency bands, the volume scan is measured separately in each frequency band. In order to sum correctly to compute the 1g aggregate SAR, the EUT remain in the same test position for all measurements and all volume scan use the same spatial resolution and grid spacing. When all volume scan were completed, the software, SEMCAD postprocessor can combine and subsequently superpose these measurement data to calculating the multiband SAR.

9.6. Power Drift Monitoring

All SAR testing is under the EUT install full charged battery and transmit maximum output power. In DASY measurement software, the power reference measurement and power drift measurement procedures are used for monitoring the power drift of EUT during SAR test. Both these procedures measure the field at a specified reference position before and after the SAR testing. The software will calculate the field difference in dB. If the power drift more than 5%, the SAR will be retested.



10. Conducted Power

<WLAN 2.4GHz Conducted Power>

ANT 1:

Mode	Channel	Frequency (MHz)	Peak Power (dBm)	Average Power(dBm)	Tune-Up Limit(dBm)	Test Rate Data
B	1	2412	19.18	18.19	18.50	1 Mbps
	6	2437	19.45	18.44	18.50	1 Mbps
	11	2462	18.62	17.63	18.50	1 Mbps
G	1	2412	19.53	16.72	17.00	6 Mbps
	6	2437	19.55	16.76	17.00	6 Mbps
	11	2462	18.91	16.10	17.00	6 Mbps
N(HT20)	1	2412	19.30	16.41	17.00	MCS0
	6	2437	19.62	16.71	17.00	MCS0
	11	2462	18.99	16.10	17.00	MCS0
N(HT40)	3	2422	19.63	17.64	18.00	MCS0
	6	2437	19.64	17.63	18.00	MCS0
	9	2452	19.36	17.37	18.00	MCS0
AX(HEW20)	1	2412	19.76	16.85	17.50	MCS0
	6	2437	20.09	17.20	17.50	MCS0
	11	2462	19.41	16.52	17.50	MCS0
AX(HEW40)	3	2422	20.01	18.02	18.50	MCS0
	6	2437	20.00	18.01	18.50	MCS0
	9	2452	19.64	17.63	18.00	MCS0

ANT 2:

Mode	Channel	Frequency (MHz)	Peak Power (dBm)	Average Power(dBm)	Tune-Up Limit(dBm)	Test Rate Data
B	1	2412	17.68	16.69	18.00	1 Mbps
	6	2437	18.91	17.90	18.00	1 Mbps
	11	2462	16.12	15.13	18.00	1 Mbps
G	1	2412	17.69	14.88	16.00	6 Mbps
	6	2437	18.67	15.86	16.00	6 Mbps
	11	2462	16.32	13.53	16.00	6 Mbps
N(HT20)	1	2412	17.72	14.81	16.00	MCS0
	6	2437	18.53	15.64	16.00	MCS0
	11	2462	16.29	13.38	16.00	MCS0



N(HT40)	3	2422	18.34	16.35	17.00	MCS0
	6	2437	18.98	16.97	17.00	MCS0
	9	2452	16.99	14.98	17.00	MCS0
AX(HEW20)	1	2412	18.21	15.32	16.50	MCS0
	6	2437	19.11	16.22	16.50	MCS0
	11	2462	16.79	13.88	16.50	MCS0
AX(HEW40)	3	2422	18.60	16.61	17.50	MCS0
	6	2437	19.23	17.22	17.50	MCS0
	9	2452	17.23	15.22	17.50	MCS0

Note:

1. Per KDB 447498 D01, the 1-g SAR test exclusion thresholds for 100 MHz to 6 GHz at *test separation distances* ≤ 50 mm are determined by:

$$[(\text{max. power of channel, including tune-up tolerance, mW}) / (\text{min. test separation distance, mm})] \cdot [\sqrt{f(\text{GHz})}] \leq 3.0 \text{ for 1-g SAR, where}$$

$f(\text{GHz})$ is the RF channel transmit frequency in GHz

Power and distance are rounded to the nearest mW and mm before calculation

The result is rounded to one decimal place for comparison

2. Base on the result of note1, RF exposure evaluation of 2.4G WIFI mode is required.

3. Per KDB 248227 D01, choose the highest output power channel to test SAR and determine further SAR exclusion.

4. Per KDB 248227 D01, In the 2.4 GHz band, separate SAR procedures are applied to DSSS and OFDM configurations to simplify DSSS test requirements. SAR is not required for the following 2.4 GHz OFDM conditions:

1) When KDB Publication 447498 SAR test exclusion applies to the OFDM configuration.

2) When the highest reported SAR for DSSS is adjusted by the ratio of OFDM to DSSS specified maximum output power and the adjusted SAR is ≤ 1.2 W/kg.



<WLAN 5GHz Conducted Power>

Band 1

ANT 1:

TestMode	Channel	Average Power[dBm]	Tune-Up Limit(dBm)	Test Rate Data
A	5180	14.96	15.00	6M
	5200	14.53	15.00	6M
	5240	14.27	15.00	6M
N(HT20)	5180	14.73	15.50	MCS0
	5200	15.43	15.50	MCS0
	5240	15.49	15.50	MCS0
N(HT40)	5190	18.32	18.50	MCS0
	5230	16.81	18.50	MCS0
AC(HT20)	5180	16.79	17.00	MCS0
	5200	16.58	17.00	MCS0
	5240	16.41	17.00	MCS0
AC(HT40)	5190	19.28	19.50	MCS0
	5230	18.44	19.50	MCS0
AC(HT80)	5210	18.22	18.50	MCS0
AX(HEW20)	5180	18.27	18.50	MCS0
	5200	18.15	18.50	MCS0
	5240	18.21	18.50	MCS0
AX(HEW40)	5190	21.17	21.50	MCS0
	5230	21.24	21.50	MCS0
AX(HEW80)	5210	20.35	20.50	MCS0



ANT 2:

TestMode	Channel	Average Power[dBm]	Tune-Up Limit(dBm)	Test Rate Data
A	5180	14.08	15.50	6M
	5200	14.69	15.50	6M
	5240	15.02	15.50	6M
N(HT20)	5180	13.54	14.00	MCS0
	5200	13.01	14.00	MCS0
	5240	13.26	14.00	MCS0
N(HT40)	5190	16.03	16.50	MCS0
	5230	16.23	16.50	MCS0
AC(HT20)	5180	14.05	15.00	MCS0
	5200	14.29	15.00	MCS0
	5240	14.93	15.00	MCS0
AC(HT40)	5190	17.38	17.50	MCS0
	5230	16.49	17.50	MCS0
AC(HT80)	5210	16.27	16.50	MCS0
AX(HEW20)	5180	15.95	16.50	MCS0
	5200	15.97	16.50	MCS0
	5240	16.26	16.50	MCS0
AX(HEW40)	5190	19.04	19.50	MCS0
	5230	19.19	19.50	MCS0
AX(HEW80)	5210	17.72	18.00	MCS0



Band 2

ANT 1:

TestMode	Channel	Average Power[dBm]	Tune-Up Limit(dBm)	Test Rate Data
A	5260	12.30	13.00	6M
	5300	12.69	13.00	6M
	5320	12.70	13.00	6M
N(HT20)	5260	12.37	14.00	MCS0
	5300	12.80	14.00	MCS0
	5320	13.56	14.00	MCS0
N(HT40)	5270	13.35	14.00	MCS0
	5310	13.54	14.00	MCS0
AC(HT20)	5260	12.35	13.00	MCS0
	5300	12.65	13.00	MCS0
	5320	12.72	13.00	MCS0
AC(HT40)	5270	14.80	15.00	MCS0
	5310	13.56	15.00	MCS0
AC(HT80)	5290	13.29	13.50	MCS0
AX(HEW20)	5260	12.62	13.50	MCS0
	5300	12.12	13.50	MCS0
	5320	12.26	13.50	MCS0
AX(HEW40)	5270	13.26	13.50	MCS0
	5310	12.95	13.50	MCS0
AX(HEW80)	5290	12.67	13.00	MCS0



ANT 2:

TestMode	Channel	Average Power[dBm]	Tune-Up Limit(dBm)	Test Rate Data
A	5260	11.15	12.00	6M
	5300	11.59	12.00	6M
	5320	11.59	12.00	6M
N(HT20)	5260	11.73	13.00	MCS0
	5300	12.71	13.00	MCS0
	5320	12.62	13.00	MCS0
N(HT40)	5270	13.24	13.50	MCS0
	5310	13.49	13.50	MCS0
AC(HT20)	5260	12.35	13.00	MCS0
	5300	12.61	13.00	MCS0
	5320	12.61	13.00	MCS0
AC(HT40)	5270	14.73	15.00	MCS0
	5310	13.46	15.00	MCS0
AC(HT80)	5290	13.23	13.50	MCS0
AX(HEW20)	5260	11.77	12.50	MCS0
	5300	12.14	12.50	MCS0
	5320	12.27	12.50	MCS0
AX(HEW40)	5270	13.17	13.50	MCS0
	5310	12.83	13.50	MCS0
AX(HEW80)	5290	14.39	14.50	MCS0



Band 4

ANT 1:

TestMode	Channel	Average Power[dBm]	Tune-Up Limit(dBm)	Test Rate Data
A	5745	17.72	18.50	6M
	5785	18.13	18.50	6M
	5825	18.18	18.50	6M
N(HT20)	5745	18.53	19.50	MCS0
	5785	19.06	19.50	MCS0
	5825	19.03	19.50	MCS0
N(HT40)	5755	19.00	19.50	MCS0
	5795	19.18	19.50	MCS0
AC(HT20)	5745	18.59	19.50	MCS0
	5785	19.16	19.50	MCS0
	5825	19.01	19.50	MCS0
AC(HT40)	5755	19.78	20.00	MCS0
	5795	19.35	20.00	MCS0
AC(HT80)	5775	18.23	18.50	MCS0
AX(HEW20)	5745	19.17	19.50	MCS0
	5785	19.00	19.50	MCS0
	5825	19.00	19.50	MCS0
AX(HEW40)	5755	18.76	19.50	MCS0
	5795	19.43	19.50	MCS0
AX(HEW80)	5775	18.57	19.00	MCS0



ANT 2:

TestMode	Channel	Average Power[dBm]	Tune-Up Limit(dBm)	Test Rate Data
A	5745	19.34	20.00	6M
	5785	19.58	20.00	6M
	5825	19.37	20.00	6M
N(HT20)	5745	19.85	20.50	MCS0
	5785	20.06	20.50	MCS0
	5825	19.84	20.50	MCS0
N(HT40)	5755	20.73	21.00	MCS0
	5795	20.29	21.00	MCS0
AC(HT20)	5745	19.83	20.50	MCS0
	5785	20.08	20.50	MCS0
	5825	19.70	20.50	MCS0
AC(HT40)	5755	20.62	21.00	MCS0
	5795	20.24	21.00	MCS0
AC(HT80)	5775	18.94	19.00	MCS0
AX(HEW20)	5745	20.01	20.50	MCS0
	5785	20.25	20.50	MCS0
	5825	20.25	20.50	MCS0
AX(HEW40)	5755	20.10	20.50	MCS0
	5795	20.34	20.50	MCS0
AX(HEW80)	5775	19.65	20.00	MCS0



Note:

1. Per KDB 447498 D01, the 1-g SAR test exclusion thresholds for 100 MHz to 6 GHz at *test separation distances* ≤ 50 mm are determined by:

$$[(\text{max. power of channel, including tune-up tolerance, mW}) / (\text{min. test separation distance, mm})] \cdot [\sqrt{f(\text{GHz})}] \leq 3.0$$
 for 1-g SAR, where

$f(\text{GHz})$ is the RF channel transmit frequency in GHz

Power and distance are rounded to the nearest mW and mm before calculation

The result is rounded to one decimal place for comparison

2. Base on the result of note1, RF exposure evaluation of 2.4G/5.2G/5.3G/5.8G WIFI mode is required.

3. Per KDB 248227 D01, choose the highest output power channel to test SAR and determine further SAR exclusion.

4. Per KDB 248227 D01, In the 2.4 GHz band, separate SAR procedures are applied to DSSS and OFDM configurations to simplify DSSS test requirements. SAR is not required for the following 2.4 GHz OFDM conditions:

1) When KDB Publication 447498 SAR test exclusion applies to the OFDM configuration.

2) When the highest reported SAR for DSSS is adjusted by the ratio of OFDM to DSSS specified maximum output power and the adjusted SAR is ≤ 1.2 W/kg.



<Bluetooth Conducted Power>

Mode	Channel	Frequency (MHz)	Conducted Peak Power (dBm)	Conducted Average Power (dBm)	Tune-up power(dBm)
BT BDR (GFSK)	00	2402	15.94	13.44	15.50
	39	2441	17.75	15.25	15.50
	78	2480	16.69	14.19	15.50
BT EDR (Π/4DQPSK)	00	2402	15.93	13.43	15.50
	39	2441	17.54	15.04	15.50
	78	2480	16.45	13.95	15.50
BT EDR (8DPSK)	00	2402	16.57	14.07	16.00
	39	2441	18.20	15.70	16.00
	78	2480	16.85	14.35	16.00
BT BLE_1M (GFSK)	00	2402	1.46	-0.04	2.00
	19	2440	3.46	1.96	2.00
	39	2480	2.54	1.04	2.00

Note:

Per KDB 447498 D01v05r02, the 1-g and 10-g SAR test exclusion thresholds for 100 MHz to 6 GHz at test separation distances ≤ 50 mm are determined by:

$$[(\text{max. power of channel, including tune-up tolerance, mW}) / (\text{min. test separation distance, mm})] \cdot [\sqrt{f(\text{GHz})}] \leq 3.0 \text{ for 1-g SAR and } \leq 7.5 \text{ for 10-g extremity SAR}$$

f(GHz) is the RF channel transmit frequency in GHz

Power and distance are rounded to the nearest mW and mm before calculation

The result is rounded to one decimal place for comparison

Bluetooth Max Power (dBm)	Separation Distance (mm)	Frequency (GHz)	exclusion thresholds
16.00	5	2.441	11.608

Per KDB 447498 D01, when the minimum test separation distance is <10 mm, a distance of 10 mm is applied to determine SAR test exclusion. The test exclusion threshold is 11.608 which is ≤ 3, SAR testing is required.



11. Antenna Location

Top Side

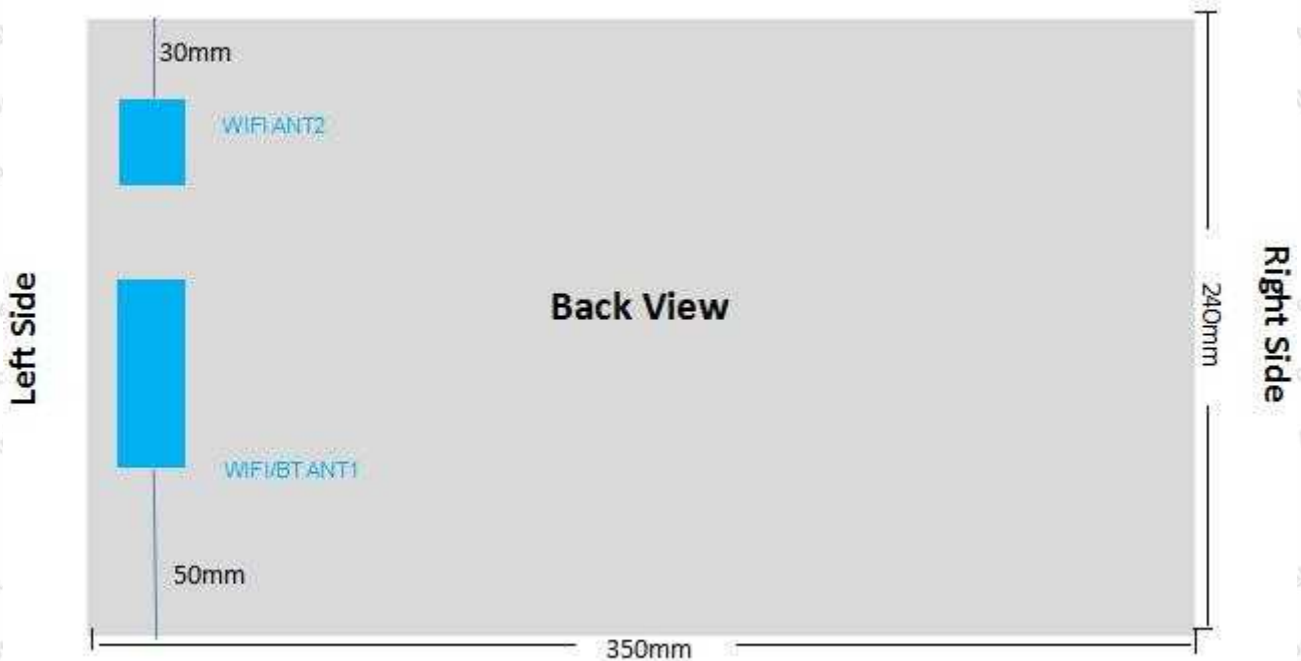

Bottom Side

Distance of The Antenna to the EUT surface and edge						
Antennas	Front	Back	Top Side	Bottom Side	Left Side	Right Side
WiFi/BT ANT 1	<25mm	<25mm	>25mm	>25mm	<25mm	>25mm
WiFi ANT 2	<25mm	<25mm	>25mm	>25mm	<25mm	>25mm



12. SAR Test Results Summary

General Note:

- Per KDB 447498 D01 v06, the reported SAR is the measured SAR value adjusted for maximum tune-up tolerance.

Scaling Factor = tune-up limit power (mW) / EUT RF power (mW), where tune-up limit is the maximum rated power among all production units.

Reported SAR(W/kg)= Measured SAR(W/kg) Scaling Factor*

- Per KDB 447498 D01 v06, for each exposure position, if the highest output channel reported SAR≤0.8W/kg, other channels SAR testing are not necessary

12.1. Body-worn and Hotspot SAR Results

<WIFI2.4GHz>

ANT 1:

Plot No.	Band	Mode	Test Position	Gap (cm)	Ch.	Freq. (MHz)	Average Power (dBm)	Tune-Up Limit (dBm)	Scaling Factor	Power Drift (dB)	Measured SAR _{1g} (W/kg)	Reported SAR _{1g} (W/kg)
#1	WIFI 2.4GHz	802.11b	Back	0	6	2437	18.44	18.50	1.014	-0.13	0.613	0.622

ANT 2:

Plot No.	Band	Mode	Test Position	Gap (cm)	Ch.	Freq. (MHz)	Average Power (dBm)	Tune-Up Limit (dBm)	Scaling Factor	Power Drift (dB)	Measured SAR _{1g} (W/kg)	Reported SAR _{1g} (W/kg)
#2	WIFI 2.4GHz	802.11b	Back	0	6	2437	17.90	18.00	1.023	0.10	0.577	0.590

<WIFI 5GHz>

ANT 1:

Plot No.	Band	Mode	Test Position	Gap (cm)	Ch.	Freq. (MHz)	Average Power (dBm)	Tune-Up Limit (dBm)	Scaling Factor	Power Drift (dB)	Measured SAR _{1g} (W/kg)	Reported SAR _{1g} (W/kg)
#3	WIFI 5.2GHz	802.11 ax40	Back	0	46	5230	21.24	21.50	1.062	-0.03	0.701	0.744

ANT 2:

Plot No.	Band	Mode	Test Position	Gap (cm)	Ch.	Freq. (MHz)	Average Power (dBm)	Tune-Up Limit (dBm)	Scaling Factor	Power Drift (dB)	Measured SAR _{1g} (W/kg)	Reported SAR _{1g} (W/kg)
#4	WIFI 5.2GHz	802.11 ax40	Back	0	46	5230	19.19	19.50	1.074	0.12	0.544	0.584



ANT 1:

Plot No.	Band	Mode	Test Position	Gap (cm)	Ch.	Freq. (MHz)	Average Power (dBm)	Tune-Up Limit (dBm)	Scaling Factor	Power Drift (dB)	Measured SAR _{1g} (W/kg)	Reported SAR _{1g} (W/kg)
#5	WIFI 5.3GHz	802.11 ac40	Back	0	54	5270	14.80	15.00	1.047	-0.05	0.503	0.527

ANT 2:

Plot No.	Band	Mode	Test Position	Gap (cm)	Ch.	Freq. (MHz)	Average Power (dBm)	Tune-Up Limit (dBm)	Scaling Factor	Power Drift (dB)	Measured SAR _{1g} (W/kg)	Reported SAR _{1g} (W/kg)
#6	WIFI 5.3GHz	802.11 ac40	Back	0	54	5270	14.73	15.00	1.064	0.13	0.463	0.493

ANT 1:

Plot No.	Band	Mode	Test Position	Gap (cm)	Ch.	Freq. (MHz)	Average Power (dBm)	Tune-Up Limit (dBm)	Scaling Factor	Power Drift (dB)	Measured SAR _{1g} (W/kg)	Reported SAR _{1g} (W/kg)
#7	WIFI 5.8GHz	802.11 ac40	Back	0	151	5755	19.78	20.00	1.052	0.11	0.702	0.738

ANT 2:

Plot No.	Band	Mode	Test Position	Gap (cm)	Ch.	Freq. (MHz)	Average Power (dBm)	Tune-Up Limit (dBm)	Scaling Factor	Power Drift (dB)	Measured SAR _{1g} (W/kg)	Reported SAR _{1g} (W/kg)
#8	WIFI 5.8GHz	802.11 N40	Back	0	151	5755	20.73	21.00	1.064	-0.05	0.645	0.686

<Bluetooth>

Plot No.	Band	Mode	Test Position	Gap (cm)	Ch.	Freq. (MHz)	Average Power (dBm)	Tune-Up Limit (dBm)	Scaling Factor	Power Drift (dB)	Measured SAR _{1g} (W/kg)	Reported SAR _{1g} (W/kg)
#9	BT EDR	8DPSK	Back	0	39	2441	15.70	16.00	1.072	-0.08	0.541	0.580



13. Simultaneous Transmission Analysis

13.1. Simultaneous TX SAR Considerations

No. Applicable Simultaneous Transmission

1. N/A

Note: WIFI 2.4GHz, WIFI 5GHz and Bluetooth cannot transmit simultaneously.



14. Measurement Uncertainty

NO	Source	Uncert. ai (%)	Prob. Dist.	Div. k	ci (1g)	ci (10g)	Stand.U ncert. ui (1g)	Stand.U ncert. ui (10g)	Veff
1	Repeat	0.4	N	1	1	1	0.4	0.4	9
Instrument									
2	Probe calibration	7	N	2	1	1	3.5	3.5	∞
3	Axial isotropy	4.7	R	$\sqrt{3}$	0.7	0.7	1.9	1.9	∞
4	Hemispherical isotropy	9.4	R	$\sqrt{3}$	0.7	0.7	3.9	3.9	∞
5	Boundary effect	1.0	R	$\sqrt{3}$	1	1	0.6	0.6	∞
6	Linearity	4.7	R	$\sqrt{3}$	1	1	2.7	2.7	∞
7	Detection limits	1.0	R	$\sqrt{3}$	1	1	0.6	0.6	∞
8	Readout electronics	0.3	N	1	1	1	0.3	0.3	∞
9	Response time	0.8	R	$\sqrt{3}$	1	1	0.5	0.5	∞
10	Integration time	2.6	R	$\sqrt{3}$	1	1	1.5	1.5	∞
11	Ambient noise	3.0	R	$\sqrt{3}$	1	1	1.7	1.7	∞
12	Ambient reflections	3.0	R	$\sqrt{3}$	1	1	1.7	1.7	∞
13	Probe positioner mech. restrictions	0.4	R	$\sqrt{3}$	1	1	0.2	0.2	∞
14	Probe positioning with respect to phantom shell	2.9	R	$\sqrt{3}$	1	1	1.7	1.7	∞
15	Max.SAR evaluation	1.0	R	$\sqrt{3}$	1	1	0.6	0.6	∞



Test sample related									
16	Device positioning	3.8	N	1	1	1	3.8	3.8	99
17	Device holder	5.1	N	1	1	1	5.1	5.1	5
18	Drift of output power	5.0	R	$\sqrt{3}$	1	1	2.9	2.9	∞
Phantom and set-up									
19	Phantom uncertainty	4.0	R	$\sqrt{3}$	1	1	2.3	2.3	∞
20	Liquid conductivity (target)	5.0	R	$\sqrt{3}$	0.64	0.43	1.8	1.2	∞
21	Liquid conductivity (meas)	2.5	N	1	0.64	0.43	1.6	1.2	∞
22	Liquid Permittivity (target)	5.0	R	$\sqrt{3}$	0.6	0.49	1.7	1.5	∞
23	Liquid Permittivity (meas)	2.5	N	1	0.6	0.49	1.5	1.2	∞
Combined standard			RSS	$U_c = \sqrt{\sum_{i=1}^n C_i^2 U_i^2}$			11.4%	11.3%	236
Expanded uncertainty(P=95%)			$U_c = k U$,k=2				22.8%	22.6%	



Appendix A. EUT Photos and Test Setup Photos



Appendix B. Plots of SAR System Check

2450MHz Body System Check

Date:05/13/2024

DUT: Dipole 2450 MHz; Type: D2450V2; Serial: 910

Communication System: CW; Frequency: 2450 MHz; Duty Cycle: 1:1

Medium parameters used (interpolated): $f = 2450$ MHz; $\sigma = 1.85$ S/m; $\epsilon_r = 39.08$; $\rho = 1000$ kg/m³

Phantom section: Flat Section

DASY5 Configuration:

Probe: EX3DV4 - SN7396; ConvF(7.53, 7.53, 7.53); Calibrated: May 06, 2024;

Sensor-Surface: 3mm (Mechanical Surface Detection)

Electronics: DAE4 Sn387; Calibrated: Sep.06.2023;

Phantom: SAM 1; Type: SAM;

Measurement SW: DASY52, Version 52.8 (1); SEMCAD X Version 14.6.5 (6469)

Area Scan (61x91x1): Measurement grid: dx=10.00 mm, dy=10.00 mm

Maximum value of SAR (interpolated) = 19.664 W/kg

Zoom Scan (7x7x7)/Cube 0: Measurement grid: dx=5mm, dy=5mm, dz=5mm

Reference Value = 84.571 V/m; Power Drift = 0.05 dB

Peak SAR (extrapolated) = 26.125 W/kg

SAR(1 g) = 12.95 W/kg; SAR(10 g) = 5.92 W/kg

Maximum value of SAR (measured) = 19.47W/kg

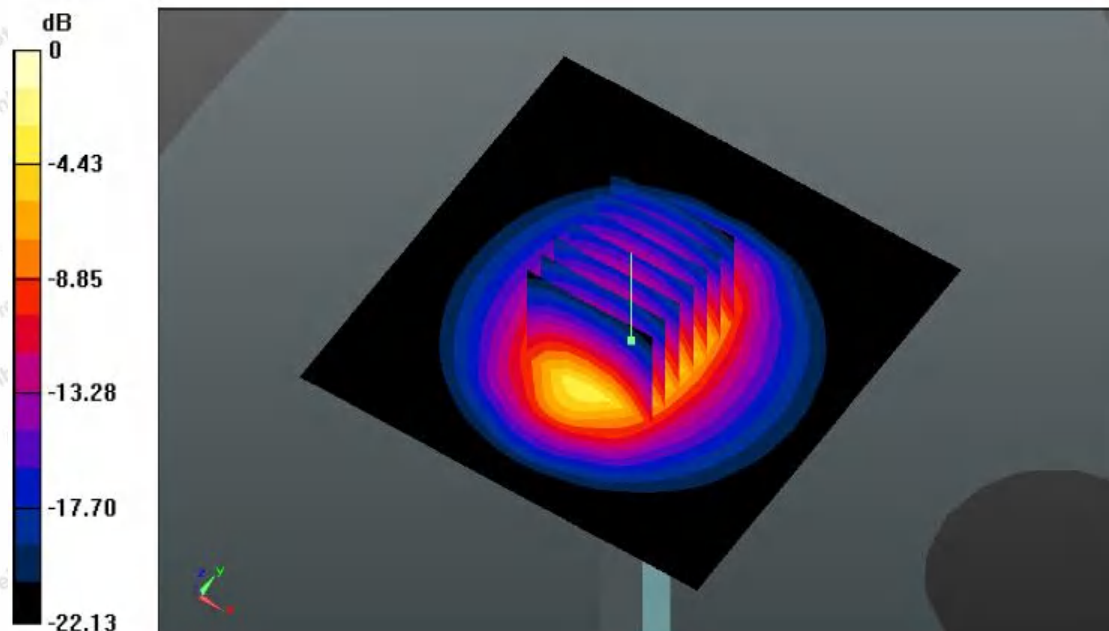

5200MHz Body System Check

Date:05/14/2024

DUT: Dipole 5 GHz; Type: D5GHzV2; Serial: D5GHzV2 - SN:1160

Communication System: UID 0, CW; Frequency: 5200 MHz; Duty Cycle: 1:1

Medium parameters used: $f = 5200$ MHz; $\sigma = 4.71$ S/m; $\epsilon_r = 36.21$; $\rho = 1000$ kg/m³

Phantom section: Flat Section

DASY5 Configuration:

- Probe: EX3DV4 – SN7396; ConvF(4.93, 4.93, 4.93); Calibrated: May 06, 2024;
- Sensor-Surface: 1.4mm (Mechanical Surface Detection)
- Electronics: DAE4 Sn387; Calibrated: Sep. 06, 2023
- Phantom: SAM2; Type: QD000P40CD; Serial: TP:1671
- Measurement SW: DASY52, Version 52.8 (7); SEMCAD X Version 14.6.10 (7164)

Configuration/Pin=100mW/Area Scan (71x71x1):Interpolated grid: dx=1.000 mm, dy=1.000 mm

Maximum value of SAR (interpolated) = 18.874 W/kg

Configuration/Pin=100mW/Zoom Scan (7x7x7)/Cube 0:Measurement grid: dx=4mm, dy=4mm, dz=1.4mm

Reference Value = 49.795 V/m; Power Drift = 0.06 dB

Peak SAR (extrapolated) = 32.687 W/kg

SAR(1 g) = 7.97 W/kg; SAR(10 g) = 2.18 W/kg

Maximum value of SAR (measured) = 19.887 W/kg

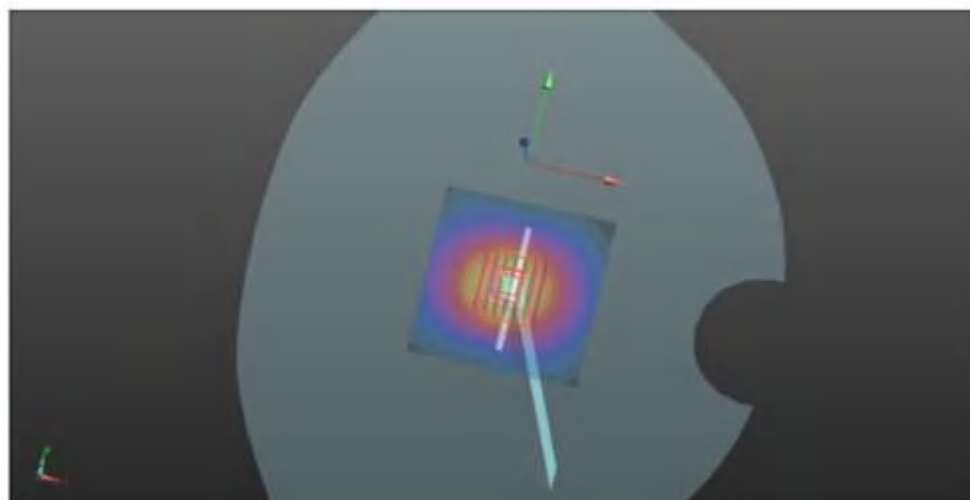
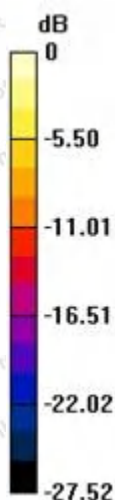

5300MHz Body System Check

Date:05/14/2024

DUT: Dipole 5GHz; Type: D5GHzV2; Serial: D5GHzV2 - SN:1160

Communication System: UID 0, CW; Frequency: 5300 MHz; Duty Cycle: 1:1

Medium parameters used: $f = 5300$ MHz; $\sigma = 4.83$ S/m; $\epsilon_r = 35.56$; $\rho = 1000$ kg/m³

Phantom section: Flat Section

DASY5 Configuration:

- Probe: EX3DV4 – SN7396; ConvF(4.93, 4.93, 4.93); Calibrated: May 06, 2024;
- Sensor-Surface: 2mm (Mechanical Surface Detection)
- Electronics: DAE4 Sn387; Calibrated: Sep. 06, 2023
- Phantom: SAM; Type: QD000P40CD; Serial: TP:1670
- Measurement SW: DASY52, Version 52.8 (2); SEMCAD X Version 14.6.10 (7164)

Configuration/Pin=100mW/Area Scan (71x71x1): Interpolated grid: dx=1.000 mm, dy=1.000 mm

Maximum value of SAR (interpolated) = 20.702 W/kg

Configuration/Pin=100mW/Zoom Scan (7x7x7)/Cube 0: Measurement grid: dx=4mm, dy=4mm, dz=1.4mm

Reference Value = 58.479 V/m; Power Drift = 0.02 dB

Peak SAR (extrapolated) = 33.826 W/kg

SAR(1 g) = 8.04 W/kg; SAR(10 g) = 2.48 W/kg

Maximum value of SAR (measured) = 20.206 W/kg

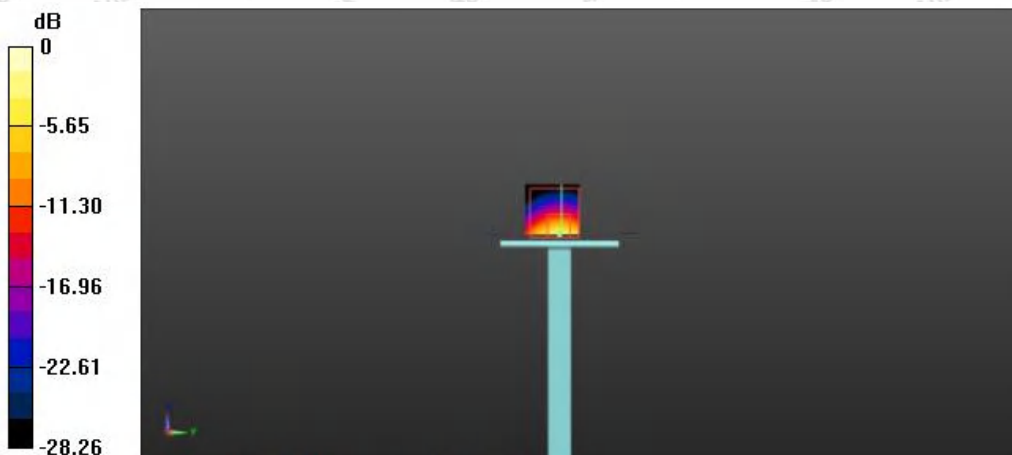

0 dB = 20.2 W/kg = 13.05 dBW/kg



5800MHz Body System Check

Date:05/14/2024

DUT: Dipole 5800 MHz; Type: D5GHzV2; Serial: D5GHzV2 - SN:1160

Communication System: UID 0, CW; Frequency: 5800 MHz;Duty Cycle: 1:1

Medium parameters used: $f = 5800$ MHz; $\sigma = 5.85$ S/m; $\epsilon_r = 48.45$; $\rho = 1000$ kg/m³

Phantom section: Flat Section

DASY5 Configuration:

- Probe: EX3DV4 – SN7396; ConvF(4.52, 4.52, 4.52); Calibrated: May 06, 2024;
- Sensor-Surface: 2mm (Mechanical Surface Detection)
- Electronics: DAE4 Sn387; Calibrated: Sep. 06, 2023
- Phantom: SAM; Type: QD000P40CD; Serial: TP:1670
- Measurement SW: DASY52, Version 52.8 (2); SEMCAD X Version 14.6.10 (7164)

Configuration/Pin=100mW/Area Scan (71x71x1): Interpolated grid: dx=1.000 mm, dy=1.000 mm

Maximum value of SAR (interpolated) = 18.8 W/kg

Configuration/Pin=100mW/Zoom Scan (7x7x7)/Cube 0: Measurement grid: dx=4mm, dy=4mm, dz=1.4mm

Reference Value = 56.663 V/m; Power Drift = 0.07 dB

Peak SAR (extrapolated) = 31.4 W/kg

SAR(1 g) = 7.99 W/kg; SAR(10 g) = 2.33 W/kg

Maximum value of SAR (measured) = 19.7 W/kg

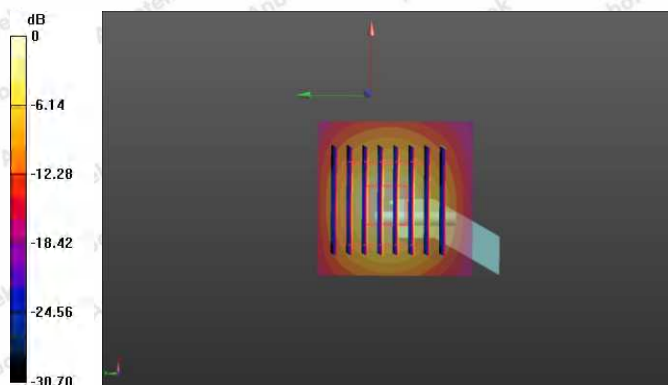

Appendix C. Plots of SAR Test Data



#1

Date: 05/13/2024

WIFI 2.4G_802.11b_Body BACK_Ch6

Communication System: UID 0, wifi (fcc) (0); Frequency: 2437 MHz;Duty Cycle: 1:1

Medium parameters used (interpolated): $f = 2437$ MHz; $\sigma = 1.85$ S/m; $\epsilon_r = 39.08$; $\rho = 1000$ kg/m³

Phantom section: Flat Section

DASY5 Configuration:

- Probe: EX3DV4 - SN7396; ConvF(7.53, 7.53, 7.53); Calibrated: May 06.2024;
- Sensor-Surface: 4mm (Mechanical Surface Detection)
- Electronics: DAE4 Sn387; Calibrated: Sep.06,2023
- Phantom: SAM 1; Type: SAM;
- Measurement SW: DASY52, Version 52.8 (2); SEMCAD X Version 14.6.10 (7164)

BODY/BACK/Area Scan (81x81x1): Measurement grid: dx=1.200mm, dy=1.200mm

Maximum value of SAR (measured) = 0.542 W/kg

BODY/BACK/Zoom Scan (7x7x7)/Cube 0: Measurement grid: dx=5mm, dy=5mm, dz=5mm

Reference Value = 5.383 V/m; Power Drift = -0.13 dB

Peak SAR (extrapolated) = 0.576 W/kg

SAR(1 g) = 0.613 W/kg; SAR(10 g) = 0.277 W/kg

Maximum value of SAR (measured) = 1.246 W/kg

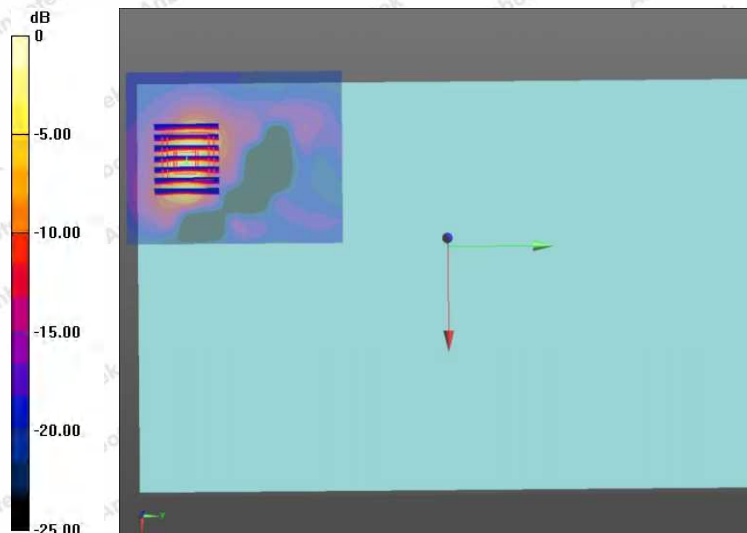

#2

Date: 05/13/2024

WIFI 2.4G_802.11b_Body BACK_Ch6

Communication System: UID 0, wifi (fcc) (0); Frequency: 2437 MHz;Duty Cycle: 1:1

Medium parameters used (interpolated): $f = 2437$ MHz; $\sigma = 1.85$ S/m; $\epsilon_r = 39.08$; $\rho = 1000$ kg/m³

Phantom section: Flat Section

DASY5 Configuration:

- Probe: EX3DV4 - SN7396; ConvF(7.53, 7.53, 7.53); Calibrated: May 06.2024;
- Sensor-Surface: 4mm (Mechanical Surface Detection)
- Electronics: DAE4 Sn387; Calibrated: Sep.06,2023
- Phantom: SAM 1; Type: SAM;
- Measurement SW: DASY52, Version 52.8 (2); SEMCAD X Version 14.6.10 (7164)

BODY/BACK/Area Scan (81x81x1): Measurement grid: dx=1.200mm, dy=1.200mm

Maximum value of SAR (measured) = 0.651 W/kg

BODY/BACK/Zoom Scan (7x7x7)/Cube 0: Measurement grid: dx=5mm, dy=5mm, dz=5mm

Reference Value = 5.258 V/m; Power Drift = 0.10 dB

Peak SAR (extrapolated) = 0.486 W/kg

SAR(1 g) = 0.577 W/kg; SAR(10 g) = 0.238 W/kg

Maximum value of SAR (measured) = 1.056 W/kg

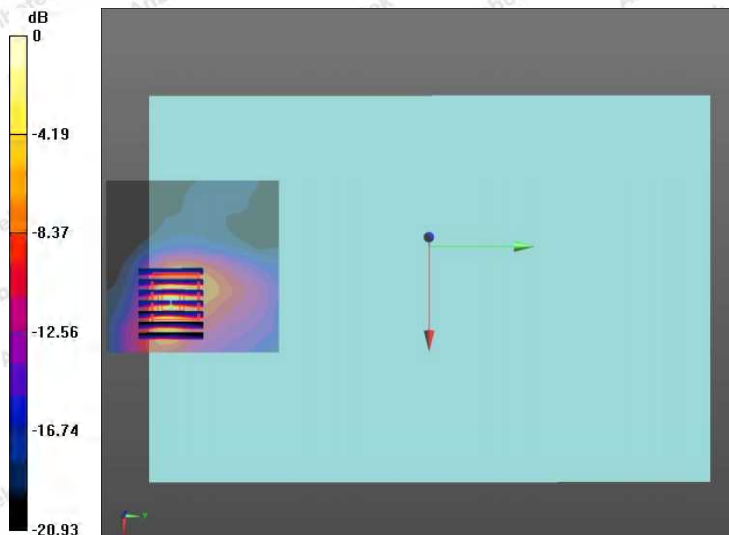

#3

Date: 05/14/2024

WIFI 5.2G_802.11ax40_Body back_Ch46

Communication System: UID 0, 802.11 (0); Frequency: 5230MHz; Duty Cycle: 1:1

Medium parameters used (interpolated): $f = 5230$ MHz; $\sigma = 4.71$ S/m; $\epsilon_r = 36.21$; $\rho = 1000$ kg/m³

Phantom section: Flat Section

DASY5 Configuration:

- Probe: EX3DV4 – SN7396; ConvF(4.93, 4.93, 4.93); Calibrated: May 06.2024;
- Sensor-Surface: 2mm (Mechanical Surface Detection)
- Electronics: DAE4 Sn387; Calibrated: Sep.06,2023
- Phantom: SAM2; Type: QD000P40CD; Serial: TP:1670
- Measurement SW: DASY52, Version 52.8 (7); SEMCAD X Version 14.6.10 (7164)

BODY/BACK/Area Scan (81x81x1):Measurement grid: dx=1.000mm, dy=1.000mm

Maximum value of SAR (measured) = 0.622W/kg

BODY/BACK/Zoom Scan (8x8x8)/Cube 0:Measurement grid: dx=4mm, dy=4mm, dz=1.4mm

Reference Value = 6.156 V/m; Power Drift = -0.03 dB

Peak SAR (extrapolated) = 0.634 W/kg

SAR(1 g) = 0.701 W/kg; SAR(10 g) = 0.342 W/kg

Maximum value of SAR (measured) = 1.594 W/kg

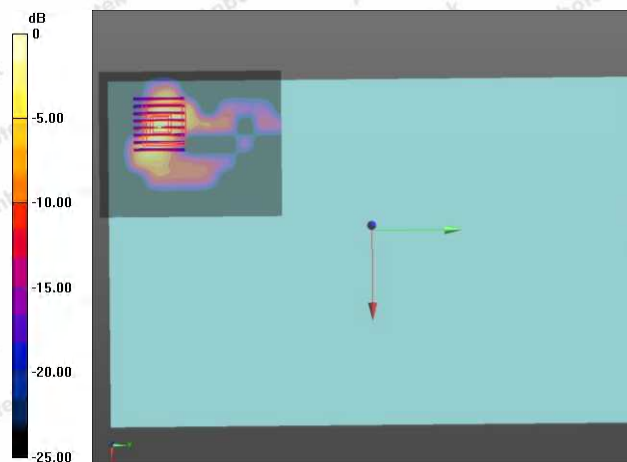

#4

Date: 05/14/2024

WIFI 5.2G_802.11ax40_Body back_Ch46

Communication System: UID 0, 802.11 (0); Frequency: 5230MHz; Duty Cycle: 1:1

Medium parameters used (interpolated): $f = 5230$ MHz; $\sigma = 4.71$ S/m; $\epsilon_r = 36.21$; $\rho = 1000$ kg/m³

Phantom section: Flat Section

DASY5 Configuration:

- Probe: EX3DV4 – SN7396; ConvF(4.93, 4.93, 4.93); Calibrated: May 06.2024;
- Sensor-Surface: 2mm (Mechanical Surface Detection)
- Electronics: DAE4 Sn387; Calibrated: Sep.06,2023
- Phantom: SAM2; Type: QD000P40CD; Serial: TP:1670
- Measurement SW: DASY52, Version 52.8 (7); SEMCAD X Version 14.6.10 (7164)

BODY/BACK/Area Scan (81x81x1):Measurement grid: dx=1.000mm, dy=1.000mm

Maximum value of SAR (measured) = 0.528 W/kg

BODY/BACK/Zoom Scan (8x8x8)/Cube 0:Measurement grid: dx=4mm, dy=4mm, dz=1.4mm

Reference Value = 6.014 V/m; Power Drift = 0.12 dB

Peak SAR (extrapolated) = 0.573 W/kg

SAR(1 g) = 0.544 W/kg; SAR(10 g) = 0.253 W/kg

Maximum value of SAR (measured) = 1.194 W/kg

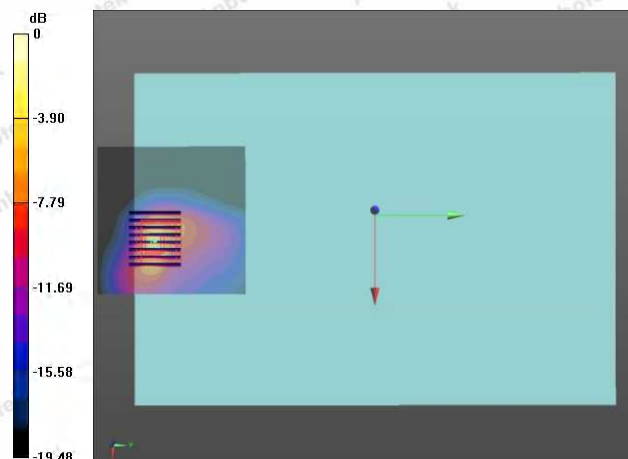

#5

Date: 05/14/2024

WIFI 5.3G_802.11ac40_Body back_Ch54

Communication System: UID 0, wifi (fcc) (0); Frequency: 5270MHz; Duty Cycle: 1:1

Medium parameters used (interpolated): $f = 5270$ MHz; $\sigma = 4.83$ S/m; $\epsilon_r = 35.56$; $\rho = 1000$ kg/m³

Phantom section: Flat Section

DASY5 Configuration:

- Probe: EX3DV4 – SN7396; ConvF(4.93, 4.93, 4.93); Calibrated: May 06, 2024;
- Sensor-Surface: 2mm (Mechanical Surface Detection)
- Electronics: DAE4 Sn387; Calibrated: Sep. 06, 2023
- Phantom: SAM; Type: QD000P40CD; Serial: TP:1670
- Measurement SW: DASY52, Version 52.8 (2); SEMCAD X Version 14.6.10 (7164)

BODY/ BACK /Area Scan (81x81x1): Measurement grid: dx=1.000mm, dy=1.000mm

Maximum value of SAR (measured) = 0.414 W/kg

BODY/ BACK /Zoom Scan (8x8x8)/Cube 0: Measurement grid: dx=4mm, dy=4mm, dz=1.4mm

Reference Value = 4.734 V/m; Power Drift = -0.05 dB

Peak SAR (extrapolated) = 0.427 W/kg

SAR(1 g) = 0.503 W/kg; SAR(10 g) = 0.224 W/kg

Maximum value of SAR (measured) = 1.123 W/kg

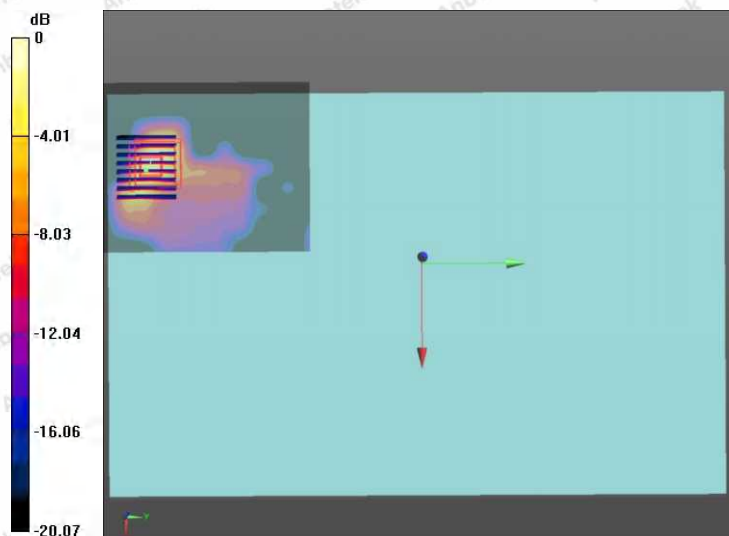

#6

Date: 05/14/2024

WIFI 5.3G_802.11ac40_Body back_Ch54

Communication System: UID 0, wifi (fcc) (0); Frequency: 5270MHz; Duty Cycle: 1:1

Medium parameters used (interpolated): $f = 5270$ MHz; $\sigma = 4.83$ S/m; $\epsilon_r = 35.56$; $\rho = 1000$ kg/m³

Phantom section: Flat Section

DASY5 Configuration:

- Probe: EX3DV4 – SN7396; ConvF(4.93, 4.93, 4.93); Calibrated: May 06, 2024;
- Sensor-Surface: 2mm (Mechanical Surface Detection)
- Electronics: DAE4 Sn387; Calibrated: Sep. 06, 2023
- Phantom: SAM; Type: QD000P40CD; Serial: TP:1670
- Measurement SW: DASY52, Version 52.8 (2); SEMCAD X Version 14.6.10 (7164)

BODY/ BACK /Area Scan (81x81x1): Measurement grid: dx=1.000mm, dy=1.000mm

Maximum value of SAR (measured) = 0.402 W/kg

BODY/ BACK /Zoom Scan (8x8x8)/Cube 0: Measurement grid: dx=4mm, dy=4mm, dz=1.4mm

Reference Value = 4.682 V/m; Power Drift = 0.13 dB

Peak SAR (extrapolated) = 0.396 W/kg

SAR(1 g) = 0.463 W/kg; SAR(10 g) = 0.214 W/kg

Maximum value of SAR (measured) = 1.015 W/kg

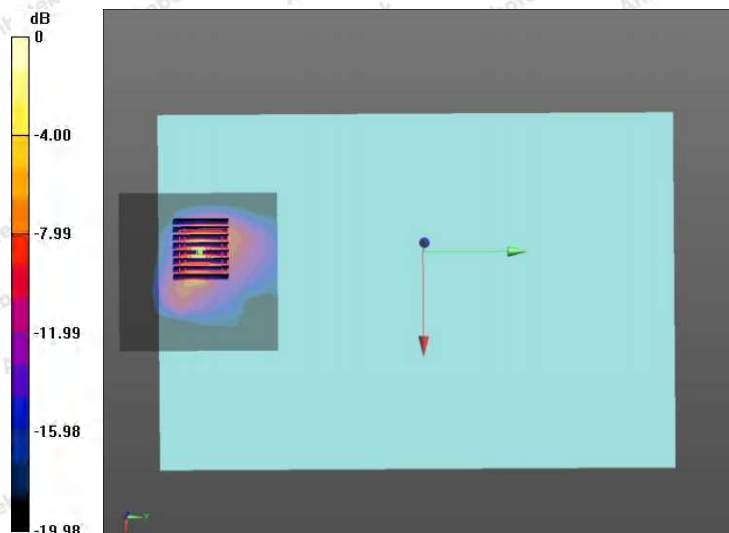

#7

Date: 05/14/2024

WIFI 5.8G_802.11ac40_CH151 BODY BACK

Communication System: UID 0, wifi (fcc) (0); Frequency: 5755 MHz; Duty Cycle: 1:1

Medium parameters used (interpolated): $f = 5755$ MHz; $\sigma = 5.85$ S/m; $\epsilon_r = 48.45$; $\rho = 1000$ kg/m³

Phantom section: Flat Section

DASY5 Configuration:

- Probe: EX3DV4 – SN7396; ConvF(4.93, 4.93, 4.93); Calibrated: May 06, 2024;
- Sensor-Surface: 2mm (Mechanical Surface Detection)
- Electronics: DAE4 Sn387; Calibrated: Sep. 06, 2023
- Phantom: SAM; Type: QD000P40CD; Serial: TP:1670
- Measurement SW: DASY52, Version 52.8 (2); SEMCAD X Version 14.6.10 (7164)

BODY BACK /Area Scan (81x81x1): Measurement grid: dx=1.000mm, dy=1.000mm

Maximum value of SAR (measured) = 1.654W/kg

BODY BACK /Zoom Scan (8x8x8)/Cube 0: Measurement grid: dx=4mm, dy=4mm, dz=1.4mm

Reference Value = 6.996 V/m; Power Drift = 0.11 dB

Peak SAR (extrapolated) = 1.266 W/kg

SAR(1 g) = 0.702 W/kg; SAR(10 g) = 0.351 W/kg

Maximum value of SAR (measured) = 1.249 W/kg

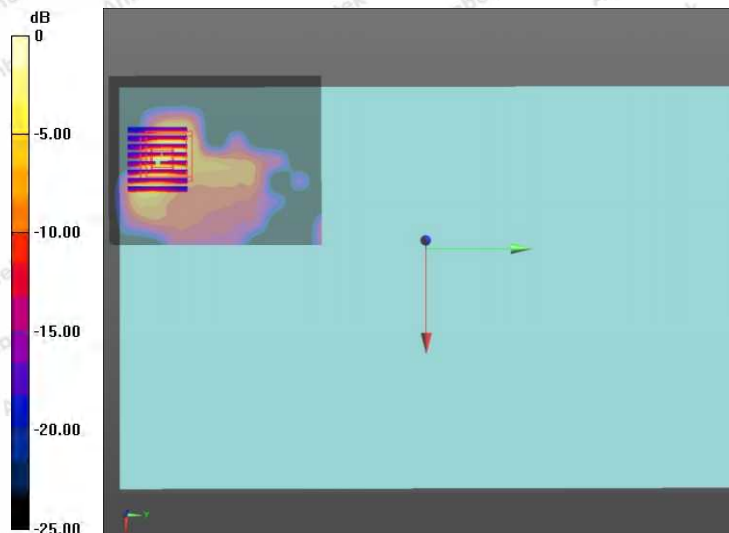

#8

Date: 05/14/2024

WIFI 5.8G_802.11ac40_CH151 BODY BACK

Communication System: UID 0, wifi (fcc) (0); Frequency: 5755 MHz; Duty Cycle: 1:1

Medium parameters used (interpolated): $f = 5755$ MHz; $\sigma = 5.85$ S/m; $\epsilon_r = 48.45$; $\rho = 1000$ kg/m³

Phantom section: Flat Section

DASY5 Configuration:

- Probe: EX3DV4 – SN7396; ConvF(4.93, 4.93, 4.93); Calibrated: May 06, 2024;
- Sensor-Surface: 2mm (Mechanical Surface Detection)
- Electronics: DAE4 Sn387; Calibrated: Sep. 06, 2023
- Phantom: SAM; Type: QD000P40CD; Serial: TP:1670
- Measurement SW: DASY52, Version 52.8 (2); SEMCAD X Version 14.6.10 (7164)

BODY BACK /Area Scan (81x81x1): Measurement grid: dx=1.000mm, dy=1.000mm

Maximum value of SAR (measured) = 1.517W/kg

BODY BACK /Zoom Scan (8x8x8)/Cube 0: Measurement grid: dx=4mm, dy=4mm, dz=1.4mm

Reference Value = 6.813 V/m; Power Drift = -0.05 dB

Peak SAR (extrapolated) = 1.682 W/kg

SAR(1 g) = 0.645 W/kg; SAR(10 g) = 0.302 W/kg

Maximum value of SAR (measured) = 1.137 W/kg

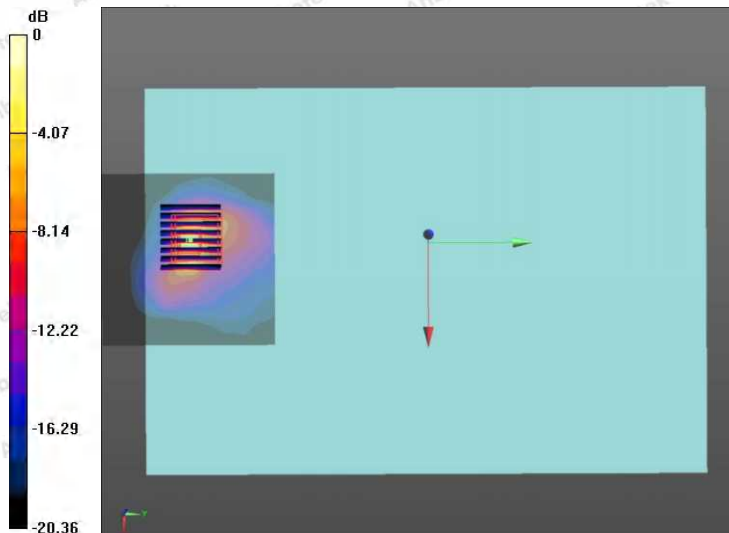

Code:AB-RF-05-b



BT EDR 8DPSK CH39 BODY BACK

Communication System: UID 0, wifi (fcc) (0); Frequency: 2441 MHz;Duty Cycle: 1:1

Medium parameters used (interpolated): $f = 2441$ MHz; $\sigma = 1.85$ S/m; $\epsilon_r = 39.08$; $\rho = 1000$ kg/m³

Phantom section: Flat Section

DASY5 Configuration:

- Probe: EX3DV4 - SN7396; ConvF(7.53, 7.53, 7.53); Calibrated: May 06, 2024;
- Sensor-Surface: 1.4mm (Mechanical Surface Detection)
- Electronics: DAE4 Sn387; Calibrated: Sep. 06, 2023
- Phantom: SAM; Type: QD000P40CD; Serial: TP:1670
- Measurement SW: DASY52, Version 52.8 (2); SEMCAD X Version 14.6.10 (7164)

BODY BACK /Area Scan (81x81x1): Interpolated grid: dx=1.200 mm, dy=1.200 mm

Maximum value of SAR (interpolated) = 1.369 W/kg

BODY BACK /Zoom Scan (7x7x7)/Cube 0: Measurement grid: dx=5mm, dy=5mm, dz=5mm

Reference Value = 8.147 V/m; Power Drift = -0.08 dB

Peak SAR (extrapolated) = 1.028 W/kg

SAR(1 g) = 0.541 W/kg; SAR(10 g) = 0.265 W/kg

Maximum value of SAR (measured) = 1.057 W/kg

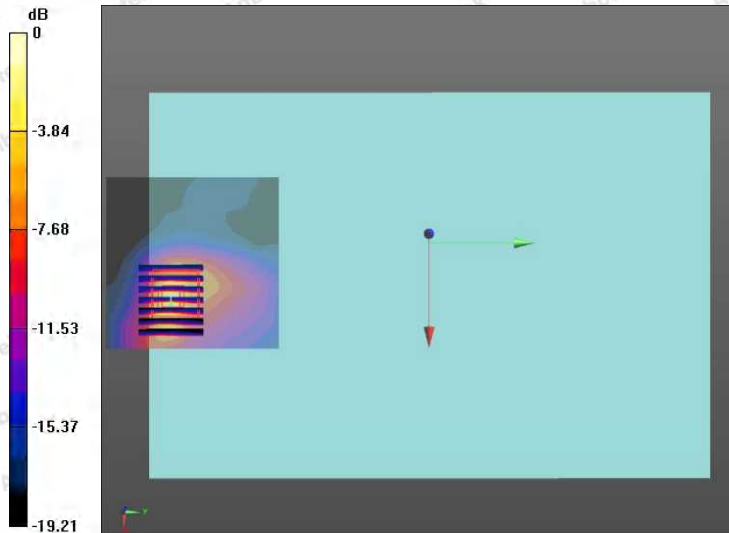

Code:AB-RF-05-b



Appendix D. DASYS System Calibration Certificate

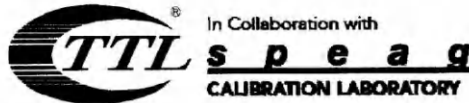

Add: No.51 Xueyuan Road, Haidian District, Beijing, 100191, China
 Tel: +86-10-62304633-2218 Fax: +86-10-62304633-2209
 E-mail: ctll@chinattl.com Http://www.chinattl.cn



中国认可
 国际互认
 校准
 CALIBRATION
 CNAS L0570

Client

Anbotek (Auden)

Certificate No: **Z23-98671**

CALIBRATION CERTIFICATE

Object: EX3DV4 - SN:7396
 Calibration Procedure(s): FF-Z12-006-08
 Calibration Procedures for Dosimetric E-field Probes
 Calibration date: May 06, 2023

This calibration Certificate documents the traceability to national standards, which realize the physical units of measurements(SI). The measurements and the uncertainties with confidence probability are given on the following pages and are part of the certificate.

All calibrations have been conducted in the closed laboratory facility: environment temperature(22±3)°C and humidity<70%.

Calibration Equipment used (M&TE critical for calibration)

Primary Standards	ID #	Cal Date(Calibrated by, Certificate No.)	Scheduled Calibration
Power Meter NRP2	101919	20-Jun-22 (CTTL, No.J22 X07447)	Jun-21
Power sensor NRP-Z91	101547	20-Jun-22 (CTTL, No.J22 X07447)	Jun-21
Power sensor NRP-Z91	101548	20-Jun-22 (CTTL, No.J22 X07447)	Jun-21
Reference10dBAttenuator	18N50W-10dB	13-Mar-23(CTTL, No.J23X01547)	Mar-22
Reference20dBAttenuator	18N50W-20dB	13-Mar-23(CTTL, No.J23X01548)	Mar-22
Reference Probe EX3DV4	SN 7433	26-Sep-22(SPEAG, No.EX3-7433_Sep22)	Sep-21
DAE4	SN 549	13-Dec-22(SPEAG, No.DAE4-549_Dec22)	Dec -21
Secondary Standards	ID #	Cal Date(Calibrated by, Certificate No.)	Scheduled Calibration
SignalGeneratorMG3700A	6201052605	27-Jun-22 (CTTL, No.J22X04776)	Jun-21
Network Analyzer E5071C	MY46110673	13-Jan-23 (CTTL, No.J23X00285)	Jan -22

	Name	Function	Signature
Calibrated by:	Yu Zongying	SAR Test Engineer	
Reviewed by:	Lin Hao	SAR Test Engineer	
Approved by:	Qi Dianyuan	SAR Project Leader	

Issued: May 06, 2023

This calibration certificate shall not be reproduced except in full without written approval of the laboratory.



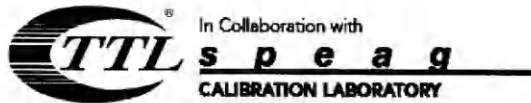

Add: No.51 Xueyuan Road, Haidian District, Beijing, 100191, China
Tel: +86-10-62304633-2218 Fax: +86-10-62304633-2209
E-mail: cttl@chinattl.com [Http://www.chinattl.cn](http://www.chinattl.cn)

Glossary:

TSL	tissue simulating liquid
NORM _{x,y,z}	sensitivity in free space
ConvF	sensitivity in TSL / NORM _{x,y,z}
DCP	diode compression point
CF	crest factor (1/duty_cycle) of the RF signal
A,B,C,D	modulation dependent linearization parameters
Polarization Φ	Φ rotation around probe axis
Polarization θ	θ rotation around an axis that is in the plane normal to probe axis (at measurement center), $\theta=0$ is normal to probe axis

Connector Angle information used in DASY system to align probe sensor X to the robot coordinate system

Calibration is Performed According to the Following Standards:

- IEEE Std 1528-2013, "IEEE Recommended Practice for Determining the Peak Spatial-Averaged Specific Absorption Rate (SAR) in the Human Head from Wireless Communications Devices: Measurement Techniques", June 2013
- IEC 62209-1, "Procedure to measure the Specific Absorption Rate (SAR) for hand-held devices used in close proximity to the ear (frequency range of 300MHz to 3GHz)", February 2005
- IEC 62209-2, "Procedure to determine the Specific Absorption Rate (SAR) for wireless communication devices used in close proximity to the human body (frequency range of 30 MHz to 6 GHz)", March 2010
- KDB 865664, "SAR Measurement Requirements for 100 MHz to 6 GHz"

Methods Applied and Interpretation of Parameters:

- NORM_{x,y,z}**: Assessed for E-field polarization $\theta=0$ ($f \leq 900\text{MHz}$ in TEM-cell; $f > 1800\text{MHz}$: waveguide). NORM_{x,y,z} are only intermediate values, i.e., the uncertainties of NORM_{x,y,z} does not effect the E^2 -field uncertainty inside TSL (see below ConvF).
- NORM(f)_{x,y,z} = NORM_{x,y,z} * frequency_response** (see Frequency Response Chart). This linearization is implemented in DASY4 software versions later than 4.2. The uncertainty of the frequency response is included in the stated uncertainty of ConvF.
- DCP_{x,y,z}**: DCP are numerical linearization parameters assessed based on the data of power sweep (no uncertainty required). DCP does not depend on frequency nor media.
- PAR**: PAR is the Peak to Average Ratio that is not calibrated but determined based on the signal characteristics.
- A_{x,y,z}; B_{x,y,z}; C_{x,y,z}; VR_{x,y,z}; A,B,C** are numerical linearization parameters assessed based on the data of power sweep for specific modulation signal. The parameters do not depend on frequency nor media. VR is the maximum calibration range expressed in RMS voltage across the diode.
- ConvF and Boundary Effect Parameters**: Assessed in flat phantom using E-field (or Temperature Transfer Standard for $f \leq 800\text{MHz}$) and inside waveguide using analytical field distributions based on power measurements for $f > 800\text{MHz}$. The same setups are used for assessment of the parameters applied for boundary compensation (alpha, depth) of which typical uncertainty valued are given. These parameters are used in DASY4 software to improve probe accuracy close to the boundary. The sensitivity in TSL corresponds to NORM_{x,y,z}* ConvF whereby the uncertainty corresponds to that given for ConvF. A frequency dependent ConvF is used in DASY version 4.4 and higher which allows extending the validity from $\pm 50\text{MHz}$ to $\pm 100\text{MHz}$.
- Spherical isotropy (3D deviation from isotropy)**: in a field of low gradients realized using a flat phantom exposed by a patch antenna.
- Sensor Offset**: The sensor offset corresponds to the offset of virtual measurement center from the probe tip (on probe axis). No tolerance required.
- Connector Angle**: The angle is assessed using the information gained by determining the NORM_x (no uncertainty required).





In Collaboration with

s p e a g
CALIBRATION LABORATORY

Add: No.51 Xueyuan Road, Haidian District, Beijing, 100191, China
Tel: +86-10-62304633-2218 Fax: +86-10-62304633-2209
E-mail: cttl@chinattl.com [Http://www.chinattl.cn](http://www.chinattl.cn)

Probe EX3DV4

SN: 7396

Calibrated: May 06, 2023

Calibrated for DASY/EASY Systems

(Note: non-compatible with DASY2 system!)





In Collaboration with
s p e a g
CALIBRATION LABORATORY

Add: No.51 Xueyuan Road, Haidian District, Beijing, 100191, China
Tel: +86-10-62304633-2218 Fax: +86-10-62304633-2209
E-mail: cttl@chinattl.com [Http://www.chinattl.cn](http://www.chinattl.cn)

DASY/EASY – Parameters of Probe: EX3DV4 – SN: 7396

Basic Calibration Parameters

	Sensor X	Sensor Y	Sensor Z	Unc (k=2)
Norm($\mu\text{V}/(\text{V}/\text{m})^2$) ^A	0.54	0.53	0.50	±10.0%
DCP(mV) ^B	97.8	104.5	102.5	

Modulation Calibration Parameters

UID	Communication System Name		A dB	B dB $\sqrt{\mu\text{V}}$	C	D dB	VR mV	Unc ^E (k=2)
0	CW	X	0.0	0.0	1.0	0.00	199.9	±2.4%
		Y	0.0	0.0	1.0		203.3	
		Z	0.0	0.0	1.0		195.0	

The reported uncertainty of measurement is stated as the standard uncertainty of Measurement multiplied by the coverage factor k=2, which for a normal distribution Corresponds to a coverage probability of approximately 95%.

^A The uncertainties of Norm X, Y, Z do not affect the E²-field uncertainty inside TSL (see Page 5 and Page 6).

^B Numerical linearization parameter: uncertainty not required.

^E Uncertainty is determined using the max. deviation from linear response applying rectangular distribution and is expressed for the square of the field value.



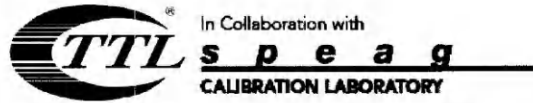

Add: No.51 Xueyuan Road, Haidian District, Beijing, 100191, China
Tel: +86-10-62304633-2218 Fax: +86-10-62304633-2209
E-mail: cttl@chinattl.com [Http://www.chinattl.cn](http://www.chinattl.cn)

DASY/EASY – Parameters of Probe: EX3DV4 – SN: 7396

Calibration Parameter Determined in Head Tissue Simulating Media

f [MHz] ^C	Relative Permittivity ^F	Conductivity (S/m) ^F	ConvF X	ConvF Y	ConvF Z	Alpha ^G	Depth ^G (mm)	Unct. (k=2)
750	41.9	0.89	9.82	9.82	9.82	0.30	0.85	± 12.1%
835	41.5	0.90	9.71	9.71	9.71	0.15	1.36	± 12.1%
900	41.5	0.97	9.87	9.87	9.87	0.16	1.37	± 12.1%
1750	40.1	1.37	8.61	8.61	8.61	0.25	1.04	± 12.1%
1900	40.0	1.40	8.13	8.13	8.13	0.24	1.01	± 12.1%
2100	39.8	1.49	8.14	8.14	8.14	0.24	1.04	± 12.1%
2300	39.5	1.67	7.85	7.85	7.85	0.40	0.75	± 12.1%
2450	39.2	1.80	7.57	7.57	7.57	0.50	0.75	± 12.1%
2600	39.0	1.96	7.38	7.38	7.38	0.64	0.68	± 12.1%
5250	35.9	4.71	5.33	5.33	5.33	0.45	1.30	± 13.3%
5600	35.5	5.07	4.89	4.89	4.89	0.45	1.35	± 13.3%
5750	35.4	5.22	4.92	4.92	4.92	0.45	1.45	± 13.3%

^C Frequency validity above 300 MHz of ±100MHz only applies for DASY v4.4 and higher (Page 2), else it is restricted to ±50MHz. The uncertainty is the RSS of ConvF uncertainty at calibration frequency and the uncertainty for the indicated frequency band. Frequency validity below 300 MHz is ± 10, 25, 40, 50 and 70 MHz for ConvF assessments at 30, 64, 128, 150 and 220 MHz respectively. Above 5 GHz frequency validity can be extended to ± 110 MHz.

^F At frequency below 3 GHz, the validity of tissue parameters (ϵ and σ) can be relaxed to ±10% if liquid compensation formula is applied to measured SAR values. At frequencies above 3 GHz, the validity of tissue parameters (ϵ and σ) is restricted to ±5%. The uncertainty is the RSS of the ConvF uncertainty for indicated target tissue parameters.

^G Alpha/Depth are determined during calibration. SPEAG warrants that the remaining deviation due to the boundary effect after compensation is always less than ± 1% for frequencies below 3 GHz and below ± 2% for the frequencies between 3-6 GHz at any distance larger than half the probe tip diameter from the boundary.





Add: No.51 Xueyuan Road, Haidian District, Beijing, 100191, China
Tel: +86-10-62304633-2218 Fax: +86-10-62304633-2209
E-mail: cttl@chinattl.com [Http://www.chinattl.cn](http://www.chinattl.cn)

DASY/EASY – Parameters of Probe: EX3DV4 – SN: 7396

Calibration Parameter Determined in Body Tissue Simulating Media

f [MHz] ^C	Relative Permittivity ^F	Conductivity (S/m) ^F	ConvF X	ConvF Y	ConvF Z	Alpha ^G	Depth ^G (mm)	Unct. (k=2)
750	55.5	0.96	10.09	10.09	10.09	0.30	0.90	± 12.1%
835	55.2	0.97	9.88	9.88	9.88	0.19	1.32	± 12.1%
900	55.0	1.05	9.82	9.82	9.82	0.23	1.15	± 12.1%
1750	53.4	1.49	8.24	8.24	8.24	0.24	1.06	± 12.1%
1900	53.3	1.52	7.97	7.97	7.97	0.19	1.24	± 12.1%
2100	53.2	1.62	8.18	8.18	8.18	0.19	1.39	± 12.1%
2300	52.9	1.81	7.88	7.88	7.88	0.55	0.80	± 12.1%
2450	52.7	1.95	7.53	7.53	7.53	0.46	0.89	± 12.1%
2600	52.5	2.16	7.38	7.38	7.38	0.52	0.80	± 12.1%
5250	48.9	5.36	4.93	4.93	4.93	0.45	1.80	± 13.3%
5600	48.5	5.77	4.19	4.19	4.19	0.48	1.90	± 13.3%
5750	48.3	5.94	4.52	4.52	4.52	0.48	1.95	± 13.3%

^C Frequency validity above 300 MHz of ±100MHz only applies for DASY v4.4 and higher (Page 2), else it is restricted to ±50MHz. The uncertainty is the RSS of ConvF uncertainty at calibration frequency and the uncertainty for the indicated frequency band. Frequency validity below 300 MHz is ± 10, 25, 40, 50 and 70 MHz for ConvF assessments at 30, 64, 128, 150 and 220 MHz respectively. Above 5 GHz frequency validity can be extended to ± 110 MHz.

^F At frequency below 3 GHz, the validity of tissue parameters (ϵ and σ) can be relaxed to ±10% if liquid compensation formula is applied to measured SAR values. At frequencies above 3 GHz, the validity of tissue parameters (ϵ and σ) is restricted to ±5%. The uncertainty is the RSS of the ConvF uncertainty for indicated target tissue parameters.

^G Alpha/Depth are determined during calibration. SPEAG warrants that the remaining deviation due to the boundary effect after compensation is always less than ± 1% for frequencies below 3 GHz and below ± 2% for the frequencies between 3-6 GHz at any distance larger than half the probe tip diameter from the boundary.





Add: No.51 Xueyuan Road, Haidian District, Beijing, 100191, China
Tel: +86-10-62304633-2218 Fax: +86-10-62304633-2209
E-mail: cttl@chinattl.com [Http://www.chinattl.cn](http://www.chinattl.cn)

Frequency Response of E-Field (TEM-Cell: ifi110 EXX, Waveguide: R22)

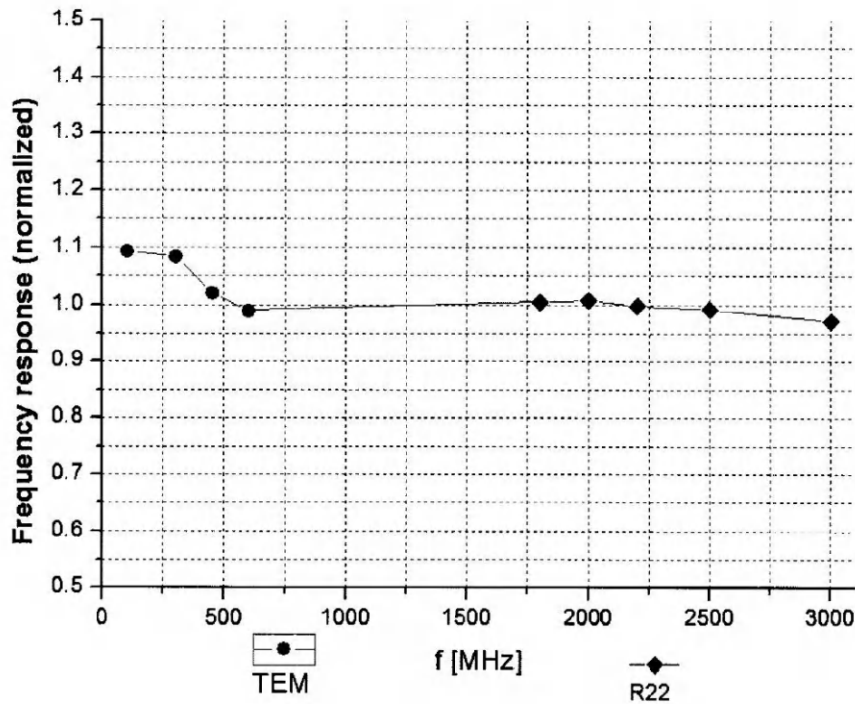

Uncertainty of Frequency Response of E-field: $\pm 7.4\%$ (k=2)



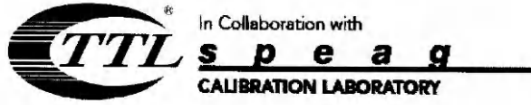

Add: No.51 Xueyuan Road, Haidian District, Beijing, 100191, China
Tel: +86-10-62304633-2218 Fax: +86-10-62304633-2209
E-mail: cttl@chinattl.com [Http://www.chinattl.cn](http://www.chinattl.cn)

Receiving Pattern (Φ), $\theta=0^\circ$

f=600 MHz, TEM

f=1800 MHz, R22

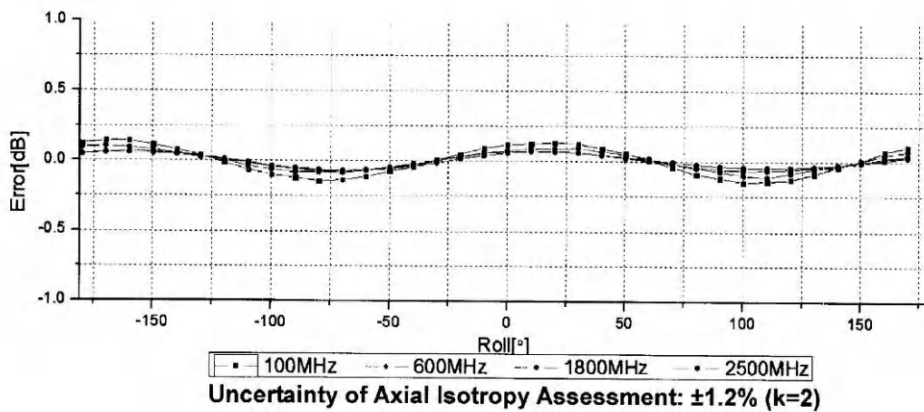
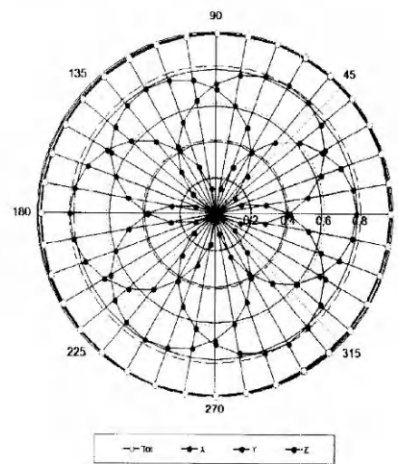
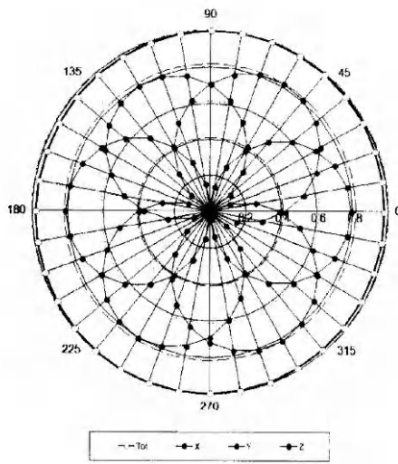



Add: No.51 Xueyuan Road, Haidian District, Beijing, 100191, China
Tel: +86-10-62304633-2218 Fax: +86-10-62304633-2209
E-mail: cttl@chinattl.com Http://www.chinattl.cn

Dynamic Range f(SAR_{head}) (TEM cell, f = 900 MHz)

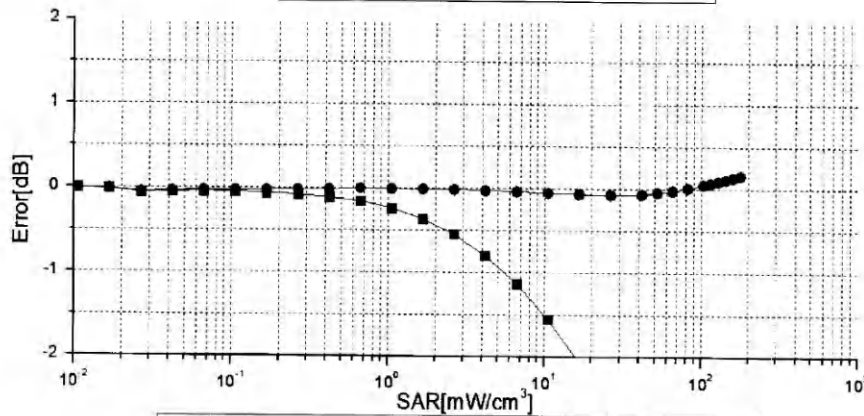
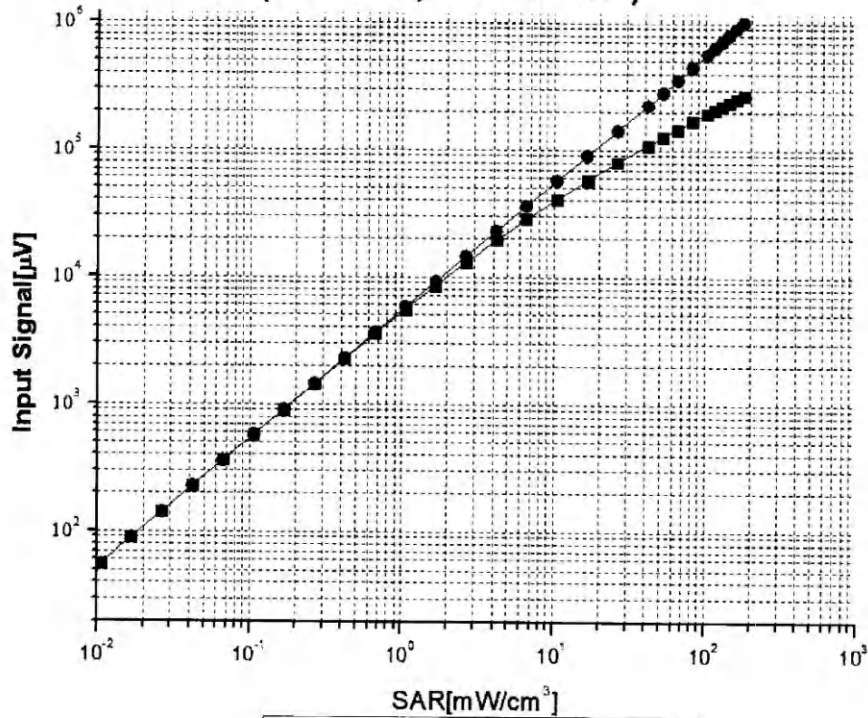

Uncertainty of Linearity Assessment: $\pm 0.9\%$ (k=2)



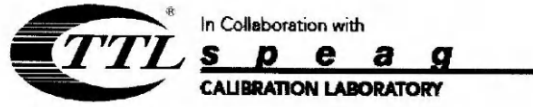

Add: No.51 Xueyuan Road, Haidian District, Beijing, 100191, China
Tel: +86-10-62304633-2218 Fax: +86-10-62304633-2209
E-mail: cttl@chinattl.com Http://www.chinattl.cn

Conversion Factor Assessment

f=900 MHz, WGLS R9(H_convF)

f=1750 MHz, WGLS R22(H_convF)

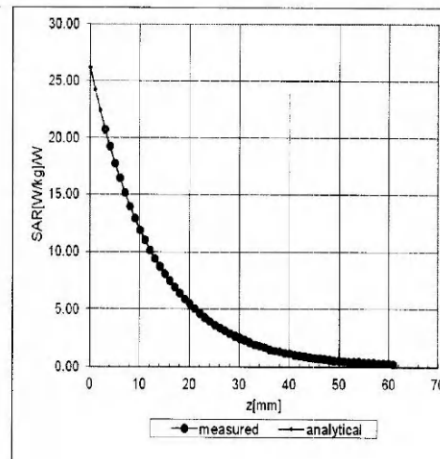
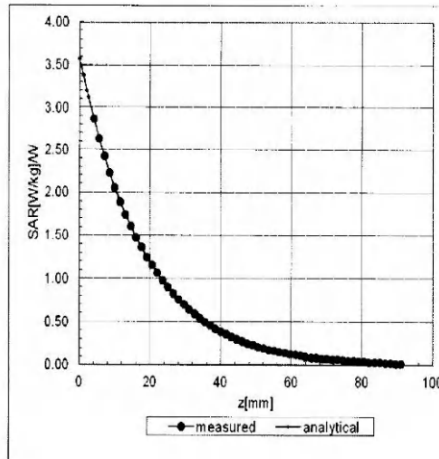

Deviation from Isotropy in Liquid

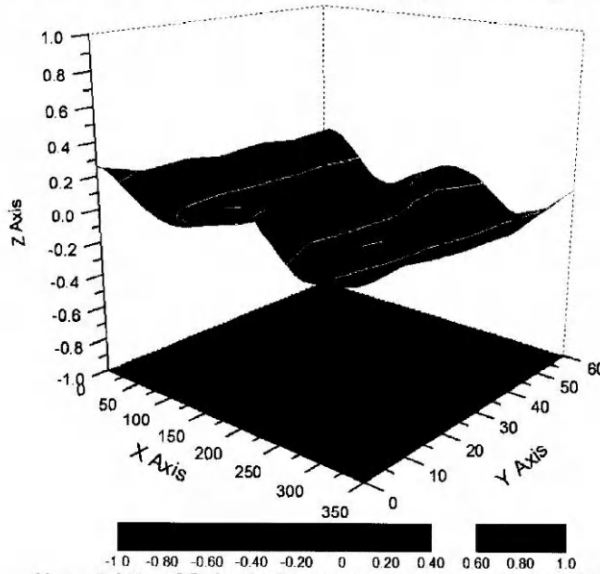

Uncertainty of Spherical Isotropy Assessment: $\pm 3.2\%$ (K=2)



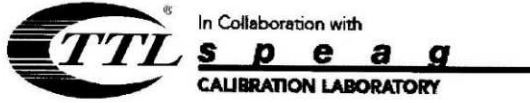

Add: No.51 Xueyuan Road, Haidian District, Beijing, 100191, China
Tel: +86-10-62304633-2218 Fax: +86-10-62304633-2209
E-mail: cttl@chinattl.com [Http://www.chinattl.cn](http://www.chinattl.cn)

DASY/EASY – Parameters of Probe: EX3DV4 – SN: 7396

Other Probe Parameters

Sensor Arrangement	Triangular
Connector Angle (°)	156.9
Mechanical Surface Detection Mode	enabled
Optical Surface Detection Mode	disable
Probe Overall Length	337mm
Probe Body Diameter	10mm
Tip Length	9mm
Tip Diameter	2.5mm
Probe Tip to Sensor X Calibration Point	1mm
Probe Tip to Sensor Y Calibration Point	1mm
Probe Tip to Sensor Z Calibration Point	1mm
Recommended Measurement Distance from Surface	1.4mm



Schmid & Partner Engineering AG

s p e a g

Zeughausstrasse 43, 8004 Zurich, Switzerland
Phone +41 44 245 9700, Fax +41 44 245 9779
info@speag.com, http://www.speag.com

IMPORTANT NOTICE

USAGE OF THE DAE 4

The DAE unit is a delicate, high precision instrument and requires careful treatment by the user. There are no serviceable parts inside the DAE. Special attention shall be given to the following points:

Battery Exchange: The battery cover of the DAE4 unit is closed using a screw, over tightening the screw may cause the threads inside the DAE to wear out.

Shipping of the DAE: Before shipping the DAE to SPEAG for calibration, remove the batteries and pack the DAE in an antistatic bag. This antistatic bag shall then be packed into a larger box or container which protects the DAE from impacts during transportation. The package shall be marked to indicate that a fragile instrument is inside.

E-Stop Failures: Touch detection may be malfunctioning due to broken magnets in the E-stop. Rough handling of the E-stop may lead to damage of these magnets. Touch and collision errors are often caused by dust and dirt accumulated in the E-stop. To prevent E-stop failure, the customer shall always mount the probe to the DAE carefully and keep the DAE unit in a non-dusty environment if not used for measurements.

Repair: Minor repairs are performed at no extra cost during the annual calibration. However, SPEAG reserves the right to charge for any repair especially if rough unprofessional handling caused the defect.

DASY Configuration Files: Since the exact values of the DAE input resistances, as measured during the calibration procedure of a DAE unit, are not used by the DASY software, a nominal value of 200 MOhm is given in the corresponding configuration file.

Important Note:

Warranty and calibration is void if the DAE unit is disassembled partly or fully by the Customer.

Important Note:

Never attempt to grease or oil the E-stop assembly. Cleaning and readjusting of the E-stop assembly is allowed by certified SPEAG personnel only and is part of the annual calibration procedure.

Important Note:

To prevent damage of the DAE probe connector pins, use great care when installing the probe to the DAE. Carefully connect the probe with the connector notch oriented in the mating position. Avoid any rotational movement of the probe body versus the DAE while turning the locking nut of the connector. The same care shall be used when disconnecting the probe from the DAE.

Schmid & Partner Engineering

TN_BR040315AD DAE4.doc

11.12.2009



Calibration Laboratory of Schmid & Partner Engineering AG
Zeughausstrasse 43, 8004 Zurich, Switzerland



S Schweizerischer Kalibrierdienst
C Service suisse d'étalonnage
S Servizio svizzero di taratura
S Swiss Calibration Service

Accredited by the Swiss Accreditation Service (SAS)

Accreditation No.: **SCS 0108**

The Swiss Accreditation Service is one of the signatories to the EA Multilateral Agreement for the recognition of calibration certificates

Client **Anbotek (Auden)**

Certificate No: **DAE4-387_Sep10**

CALIBRATION CERTIFICATE

Object **DAE4 - SD 000 D04 BM - SN: 387**

Calibration procedure(s) **QA CAL-06.v29
Calibration procedure for the data acquisition electronics (DAE)**

Calibration date: **September 06, 2023**

This calibration certificate documents the traceability to national standards, which realize the physical units of measurements (SI). The measurements and the uncertainties with confidence probability are given on the following pages and are part of the certificate.

All calibrations have been conducted in the closed laboratory facility: environment temperature (22 ± 3)°C and humidity < 70%.

Calibration Equipment used (M&TE critical for calibration)

Primary Standards	ID #	Cal Date (Certificate No.)	Scheduled Calibration
Keithley Multimeter Type 2001	SN: 0810278	15-Aug-23 (No:22092)	Aug-22
Secondary Standards	ID #	Check Date (in house)	Scheduled Check
Auto DAE Calibration Unit	SE UWS 053 AA 1001	05-Jan-23 (in house check)	In house check: Jan-23
Calibrator Box V2.1	SE UMS 006 AA 1002	05-Jan-23 (in house check)	In house check: Jan-23

Calibrated by:

Name	Function	Signature
Dominique Steffen	Laboratory Technician	

Approved by:

Sven Kühn	Deputy Manager	
-----------	----------------	--

Issued: September 06, 2023

This calibration certificate shall not be reproduced except in full without written approval of the laboratory.



**Calibration Laboratory of
Schmid & Partner
Engineering AG**
Zeughausstrasse 43, 8004 Zurich, Switzerland



S Schweizerischer Kalibrierdienst
C Service suisse d'étalonnage
S Servizio svizzero di taratura
S Swiss Calibration Service

Accredited by the Swiss Accreditation Service (SAS)

The Swiss Accreditation Service is one of the signatories to the EA
Multilateral Agreement for the recognition of calibration certificates

Accreditation No.: **SCS 0108**

Glossary

DAE data acquisition electronics
Connector angle information used in DASY system to align probe sensor X to the robot coordinate system.

Methods Applied and Interpretation of Parameters

- *DC Voltage Measurement:* Calibration Factor assessed for use in DASY system by comparison with a calibrated instrument traceable to national standards. The figure given corresponds to the full scale range of the voltmeter in the respective range.
- *Connector angle:* The angle of the connector is assessed measuring the angle mechanically by a tool inserted. Uncertainty is not required.
- The following parameters as documented in the Appendix contain technical information as a result from the performance test and require no uncertainty.
 - *DC Voltage Measurement Linearity:* Verification of the Linearity at +10% and -10% of the nominal calibration voltage. Influence of offset voltage is included in this measurement.
 - *Common mode sensitivity:* Influence of a positive or negative common mode voltage on the differential measurement.
 - *Channel separation:* Influence of a voltage on the neighbor channels not subject to an input voltage.
 - *AD Converter Values with inputs shorted:* Values on the internal AD converter corresponding to zero input voltage
 - *Input Offset Measurement:* Output voltage and statistical results over a large number of zero voltage measurements.
 - *Input Offset Current:* Typical value for information; Maximum channel input offset current, not considering the input resistance.
 - *Input resistance:* Typical value for information: DAE input resistance at the connector, during internal auto-zeroing and during measurement.
 - *Low Battery Alarm Voltage:* Typical value for information. Below this voltage, a battery alarm signal is generated.
 - *Power consumption:* Typical value for information. Supply currents in various operating modes.



DC Voltage Measurement

A/D - Converter Resolution nominal

High Range: 1LSB = 6.1 μ V, full range = -100...+300 mV

Low Range: 1LSB = 61nV, full range = -1.....+3mV

DASY measurement parameters: Auto Zero Time: 3 sec; Measuring time: 3 sec

Calibration Factors	X	Y	Z
High Range	404.489 \pm 0.02% (k=2)	404.852 \pm 0.02% (k=2)	404.862 \pm 0.02% (k=2)
Low Range	3.97827 \pm 1.50% (k=2)	3.95875 \pm 1.50% (k=2)	3.97982 \pm 1.50% (k=2)

Connector Angle

Connector Angle to be used in DASY system	53.0 $^{\circ}$ \pm 1 $^{\circ}$
---	------------------------------------



Appendix (Additional assessments outside the scope of SCS0108)

1. DC Voltage Linearity

High Range	Reading (μV)	Difference (μV)	Error (%)
Channel X + Input	200032.85	-3.31	-0.00
Channel X + Input	20007.64	1.88	0.01
Channel X - Input	-20003.48	1.18	-0.01
Channel Y + Input	200034.23	-1.43	-0.00
Channel Y + Input	20006.60	0.91	0.00
Channel Y - Input	-20004.04	0.72	-0.00
Channel Z + Input	200035.38	-0.83	-0.00
Channel Z + Input	20003.69	-2.11	-0.01
Channel Z - Input	-20006.38	-1.59	0.01

Low Range	Reading (μV)	Difference (μV)	Error (%)
Channel X + Input	2001.63	0.08	0.00
Channel X + Input	202.29	0.70	0.35
Channel X - Input	-197.90	0.60	-0.30
Channel Y + Input	2001.33	-0.07	-0.00
Channel Y + Input	200.86	-0.60	-0.30
Channel Y - Input	-199.87	-1.23	0.62
Channel Z + Input	2001.61	0.27	0.01
Channel Z + Input	200.60	-0.70	-0.35
Channel Z - Input	-199.51	-0.85	0.43

2. Common mode sensitivity

DASY measurement parameters: Auto Zero Time: 3 sec; Measuring time: 3 sec

	Common mode Input Voltage (mV)	High Range Average Reading (μV)	Low Range Average Reading (μV)
Channel X	200	13.50	11.56
	-200	-8.64	-11.18
Channel Y	200	-0.81	-1.28
	-200	1.05	0.09
Channel Z	200	7.17	6.91
	-200	-9.46	-9.01

3. Channel separation

DASY measurement parameters: Auto Zero Time: 3 sec; Measuring time: 3 sec

	Input Voltage (mV)	Channel X (μV)	Channel Y (μV)	Channel Z (μV)
Channel X	200	-	-1.70	0.33
Channel Y	200	10.70	-	-0.38
Channel Z	200	7.11	7.89	-



4. AD-Converter Values with inputs shorted

DASY measurement parameters: Auto Zero Time: 3 sec; Measuring time: 3 sec

	High Range (LSB)	Low Range (LSB)
Channel X	15969	17466
Channel Y	15661	16162
Channel Z	15990	16190

5. Input Offset Measurement

DASY measurement parameters: Auto Zero Time: 3 sec; Measuring time: 3 sec
Input 10M Ω

	Average (μ V)	min. Offset (μ V)	max. Offset (μ V)	Std. Deviation (μ V)
Channel X	0.73	-2.58	3.29	0.62
Channel Y	0.41	-0.49	1.23	0.40
Channel Z	-0.80	-1.88	0.30	0.42

6. Input Offset Current

Nominal Input circuitry offset current on all channels: <25fA

7. Input Resistance (Typical values for information)

	Zeroing (kOhm)	Measuring (MOhm)
Channel X	200	200
Channel Y	200	200
Channel Z	200	200

8. Low Battery Alarm Voltage (Typical values for information)

Typical values	Alarm Level (VDC)
Supply (+ Vcc)	+7.9
Supply (- Vcc)	-7.6

9. Power Consumption (Typical values for information)

Typical values	Switched off (mA)	Stand by (mA)	Transmitting (mA)
Supply (+ Vcc)	+0.01	+6	+14
Supply (- Vcc)	-0.01	-8	-9





In Collaboration with
s p e a g
CALIBRATION LABORATORY



中国认可
国际互认
校准
CALIBRATION
CNAS L0570

Add: No.51 Xueyuan Road, Haidian District, Beijing, 100191, China
Tel: +86-10-62304633-2079 Fax: +86-10-62304633-2504
E-mail: cttl@chinattl.com [Http://www.chinattl.cn](http://www.chinattl.cn)

Client **Anbotek (Auden)**

Certificate No: **Z21-97091**

CALIBRATION CERTIFICATE

Object **D2450V2 - SN: 910**

Calibration Procedure(s) **FD-Z21-2-003-01**
Calibration Procedures for dipole validation kits

Calibration date: **Jun 15, 2021**

This calibration Certificate documents the traceability to national standards, which realize the physical units of measurements(SI). The measurements and the uncertainties with confidence probability are given on the following pages and are part of the certificate.

All calibrations have been conducted in the closed laboratory facility: environment temperature(22±3)°C and humidity<70%.

Calibration Equipment used (M&TE critical for calibration)

Primary Standards	ID #	Cal Date(Calibrated by, Certificate No.)	Scheduled Calibration
Power Meter NRP2	101919	01-Jul-20 (CTTL, No.J20X04256)	Jun-21
Power sensor NRP-Z91	101547	01-Jul-20 (CTTL, No.J20X04256)	Jun-21
Reference Probe EX3DV4	SN 7307	19-Feb-21(SPEAG,No.EX3-7307_Feb21)	Feb-22
DAE4	SN 771	02-Feb-21(CTTL-SPEAG,No.Z21-97011)	Feb-22

Secondary Standards	ID #	Cal Date(Calibrated by, Certificate No.)	Scheduled Calibration
Signal Generator E4438C	MY49071430	01-Feb-21 (CTTL, No.J18X00893)	Jan-22
Network Analyzer E5071C	MY46110673	26-Jan-21 (CTTL, No.J18X00894)	Jan-22

	Name	Function	Signature
Calibrated by:	Zhao Jing	SAR Test Engineer	
Reviewed by:	Qi Dianyuan	SAR Project Leader	
Approved by:	Lu Bingsong	Deputy Director of the laboratory	

Issued: Jun 17, 2021

This calibration certificate shall not be reproduced except in full without written approval of the laboratory.





In Collaboration with

s p e a k
 CALIBRATION LABORATORY

Add: No.51 Xueyuan Road, Haidian District, Beijing, 100191, China
 Tel: +86-10-62304633-2079 Fax: +86-10-62304633-2504
 E-mail: cll@chinaatl.com Http://www.chinaatl.cn

Glossary:

TSL	tissue simulating liquid
ConyF	sensitivity in TSL / NORM _{x,y,z}
N/A	not applicable or not measured

Calibration is Performed According to the Following Standards:

- IEEE Std 1528-2013, "IEEE Recommended Practice for Determining the Peak Spatial-Averaged Specific Absorption Rate (SAR) in the Human Head from Wireless Communications Devices: Measurement Techniques", June 2013
- IEC 62209-1, "Procedure to measure the Specific Absorption Rate (SAR) For hand-held devices used in close proximity to the ear (frequency range of 300MHz to 3GHz)", February 2005
- IEC 62209-2, "Procedure to measure the Specific Absorption Rate (SAR) For wireless communication devices used in close proximity to the human body (frequency range of 30MHz to 6GHz)", March 2010
- KDB865864, SAR Measurement Requirements for 100 MHz to 6 GHz

Additional Documentation:

- DASY4/5 System Handbook

Methods Applied and Interpretation of Parameters:

- Measurement Conditions:** Further details are available from the Validation Report at the end of the certificate. All figures stated in the certificate are valid at the frequency indicated.
- Antenna Parameters with TSL:** The dipole is mounted with the spacer to position its feed point exactly below the center marking of the flat phantom section, with the arms oriented parallel to the body axis.
- Feed Point Impedance and Return Loss:** These parameters are measured with the dipole positioned under the liquid filled phantom. The impedance stated is transformed from the measurement at the SMA connector to the feed point. The Return Loss ensures low reflected power. No uncertainty required.
- Electrical Delay:** One-way delay between the SMA connector and the antenna feed point. No uncertainty required.
- SAR measured:** SAR measured at the stated antenna input power.
- SAR normalized:** SAR as measured, normalized to an input power of 1 W at the antenna connector.
- SAR for nominal TSL parameters:** The measured TSL parameters are used to calculate the nominal SAR result.

The reported uncertainty of measurement is stated as the standard uncertainty of Measurement multiplied by the coverage factor $k=2$, which for a normal distribution corresponds to a coverage probability of approximately 95%.





In Collaboration with
s p e a g
CALIBRATION LABORATORY

Add: No.31 Xueyuan Road, Haidian District, Beijing, 100191, China
Tel: +86-10-62304633-2079 Fax: +86-10-62304633-2504
E-mail: cttl@chinattl.com Http://www.chinattl.cn

Measurement Conditions

DASY system configuration, as far as not given on page 1.

DASY Version	DASY52	52.8.8.1258
Extrapolation	Advanced Extrapolation	
Phantom	Triple Flat Phantom 5.1C	
Distance Dipole Center - TSL	10 mm	with Spacer
Zoom Scan Resolution	dx, dy, dz = 5 mm	
Frequency	2450 MHz ± 1 MHz	

Head TSL parameters

The following parameters and calculations were applied.

	Temperature	Permittivity	Conductivity
Nominal Head TSL parameters	22.0 °C	39.2	1.80 mho/m
Measured Head TSL parameters	(22.0 ± 0.2) °C	39.0 ± 6 %	1.77 mho/m ± 6 %
Head TSL temperature change during test	<1.0 °C	---	---

SAR result with Head TSL

SAR averaged over 1 cm ³ (1 g) of Head TSL	Condition	
SAR measured	250 mW input power	13.0 mW / g
SAR for nominal Head TSL parameters	normalized to 1W	52.4 mW / g ± 20.8 % (k=2)
SAR averaged over 10 cm ³ (10 g) of Head TSL	Condition	
SAR measured	250 mW input power	6.06 mW / g
SAR for nominal Head TSL parameters	normalized to 1W	24.3 mW / g ± 20.4 % (k=2)

Body TSL parameters

The following parameters and calculations were applied.

	Temperature	Permittivity	Conductivity
Nominal Body TSL parameters	22.0 °C	52.7	1.95 mho/m
Measured Body TSL parameters	(22.0 ± 0.2) °C	52.9 ± 6 %	1.97 mho/m ± 6 %
Body TSL temperature change during test	<1.0 °C	---	---

SAR result with Body TSL

SAR averaged over 1 cm ³ (1 g) of Body TSL	Condition	
SAR measured	250 mW input power	13.0 mW / g
SAR for nominal Body TSL parameters	normalized to 1W	51.8 mW / g ± 20.8 % (k=2)
SAR averaged over 10 cm ³ (10 g) of Body TSL	Condition	
SAR measured	250 mW input power	6.18 mW / g
SAR for nominal Body TSL parameters	normalized to 1W	24.7 mW / g ± 20.4 % (k=2)





In Collaboration with
s p e a g
CALIBRATION LABORATORY

Add: No.51 Xueyuan Road, Haidian District, Beijing, 100191, China
Tel: +86-10-62304633-2079 Fax: +86-10-62304633-2504
E-mail: cttl@chinattl.com Http://www.chinattl.cn

Appendix

Antenna Parameters with Head TSL

Impedance, transformed to feed point	54.6Ω+ 2.77jΩ
Return Loss	- 25.8dB

Antenna Parameters with Body TSL

Impedance, transformed to feed point	50.7Ω+ 4.28jΩ
Return Loss	- 27.3dB

General Antenna Parameters and Design

Electrical Delay (one direction)	1.263 ns
----------------------------------	----------

After long term use with 100W radiated power, only a slight warming of the dipole near the feedpoint can be measured.

The dipole is made of standard semirigid coaxial cable. The center conductor of the feeding line is directly connected to the second arm of the dipole. The antenna is therefore short-circuited for DC-signals. On some of the dipoles, small end caps are added to the dipole arms in order to improve matching when loaded according to the position as explained in the "Measurement Conditions" paragraph. The SAR data are not affected by this change. The overall dipole length is still according to the Standard. No excessive force must be applied to the dipole arms, because they might bend or the soldered connections near the feedpoint may be damaged.

Additional EUT Data

Manufactured by	SPEAG
-----------------	-------





In Collaboration with
s p e a g
CALIBRATION LABORATORY

Add: No.51 Xueyuan Road, Haidian District, Beijing, 100191, China
Tel: +86-10-62304633-2079 Fax: +86-10-62304633-2504
E-mail: cttl@chinattl.com Http://www.chinattl.cn

DASY5 Validation Report for Head TSL

Date: 06.15.2021

Test Laboratory: CTTL, Beijing, China

DUT: Dipole 2450 MHz; Type: D2450V2; Serial: D2450V2 - SN: 910

Communication System: UID 0, CW; Frequency: 2450 MHz; Duty Cycle: 1:1

Medium parameters used: $f = 2450$ MHz; $\sigma = 1.767$ S/m; $\epsilon_r = 39.01$; $\rho = 1000$ kg/m³

Phantom section: Right Section

Measurement Standard: DASY5 (IEEE/IEC/ANSI C63.19-2007)

DASY5 Configuration:

- Probe: EX3DV4 - SN7307; ConvF(7.36, 7.36, 7.36); Calibrated: 2/19/2021;
- Sensor-Surface: 2mm (Mechanical Surface Detection)
- Electronics: DAE4 Sn771; Calibrated: 2021-02-02
- Phantom: Triple Flat Phantom 5.1C; Type: QD 000 P51 CA; Serial: 1161/1
- Measurement SW: DASY52, Version 52.8 (8); SEMCAD X Version 14.6.10 (7372)

Dipole Calibration/Zoom Scan (7x7x7) (7x7x7)/Cube 0: Measurement grid: dx=5mm, dy=5mm, dz=5mm

Reference Value = 106.5 V/m; Power Drift = 0.02 dB

Peak SAR (extrapolated) = 26.7 W/kg

SAR(1 g) = 13 W/kg; SAR(10 g) = 6.06 W/kg

Maximum value of SAR (measured) = 19.7 W/kg

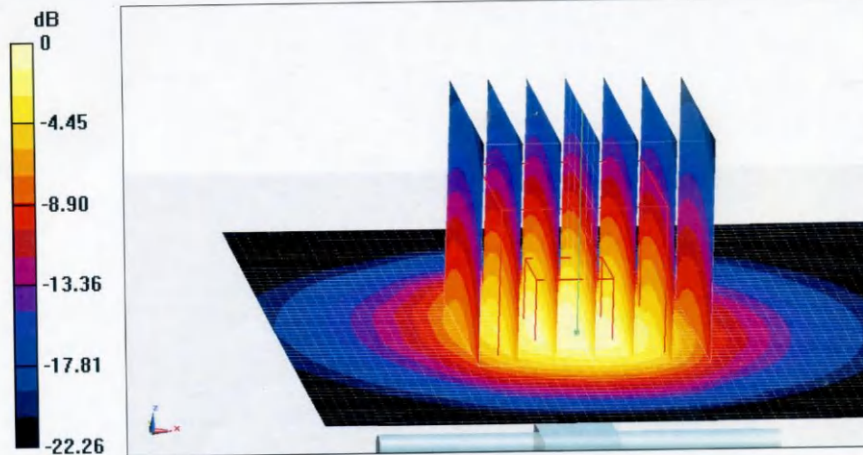

0 dB = 19.7 W/kg = 12.94 dBW/kg





In Collaboration with
s p e a g
CALIBRATION LABORATORY

Add: No.51 Xueyuan Road, Haidian District, Beijing, 100191, China
Tel: +86-10-62304633-2079 Fax: +86-10-62304633-2504
E-mail: cttl@chinattl.com Http://www.chinattl.cn

Impedance Measurement Plot for Head TSL

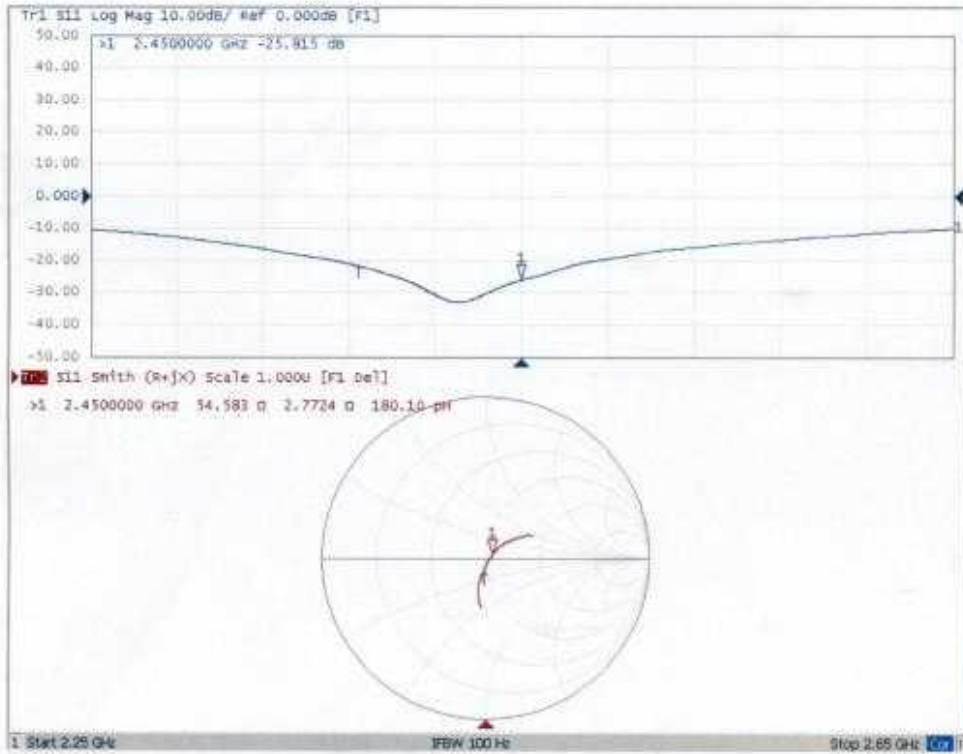



In Collaboration with
s p e a g
CALIBRATION LABORATORY

Add: No.51 Xueyuan Road, Haidian District, Beijing, 100191, China
Tel: +86-10-62304633-2079 Fax: +86-10-62304633-2504
E-mail: ctll@chinattl.com Http://www.chinattl.cn

DASY5 Validation Report for Body TSL

Date: 06.15.2021

Test Laboratory: CTTL, Beijing, China

DUT: Dipole 2450 MHz; Type: D2450V2; Serial: D2450V2 - SN: 910

Communication System: UID 0, CW; Frequency: 2450 MHz; Duty Cycle: 1:1

Medium parameters used: $f = 2450$ MHz; $\sigma = 1.972$ S/m; $\epsilon_r = 52.92$; $\rho = 1000$ kg/m³

Phantom section: Center Section

Measurement Standard: DASY5 (IEEE/IEC/ANSI C63.19-2007)

DASY5 Configuration:

- Probe: EX3DV4 - SN7307; ConvF(7.22, 7.22, 7.22); Calibrated: 2/19/2021;
- Sensor-Surface: 2mm (Mechanical Surface Detection)
- Electronics: DAE4 Sn771; Calibrated: 2021-02-02
- Phantom: Triple Flat Phantom 5.1C; Type: QD 000 P51 CA; Serial: 1161/1
- Measurement SW: DASY52, Version 52.8 (8); SEMCAD X Version 14.6.10 (7372)

Dipole Calibration/Zoom Scan (7x7x7) (7x7x7)/Cube 0: Measurement grid: dx=5mm, dy=5mm, dz=5mm

Reference Value = 98.89 V/m; Power Drift = 0.03 dB

Peak SAR (extrapolated) = 25.6 W/kg

SAR(1 g) = 13 W/kg; SAR(10 g) = 6.18 W/kg

Maximum value of SAR (measured) = 19.3 W/kg

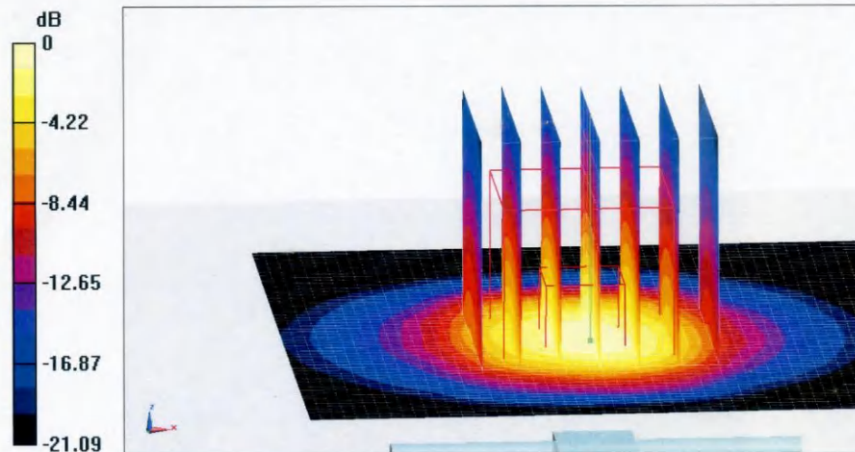

0 dB = 19.3 W/kg = 12.86 dBW/kg





In Collaboration with
s p e a g
CALIBRATION LABORATORY

Add: No.51 Xueyuan Road, Haidian District, Beijing, 100191, China
Tel: +86-10-62304633-2079 Fax: +86-10-62304633-2504
E-mail: cttl@chinattl.com Http://www.chinattl.cn

Impedance Measurement Plot for Body TSL

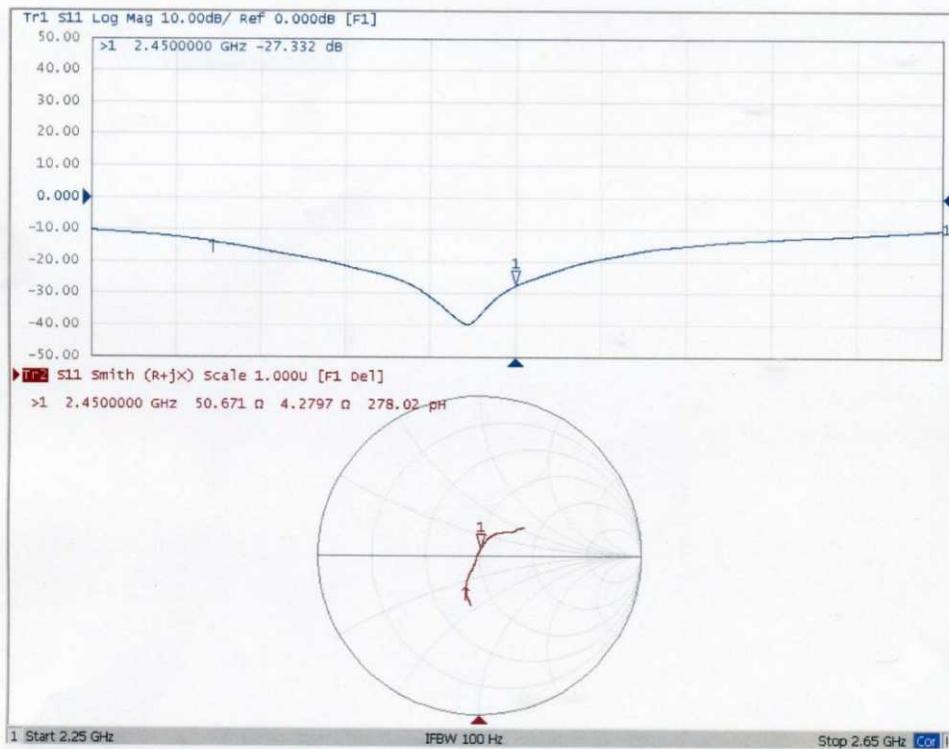

**Calibration Laboratory of
Schmid & Partner
Engineering AG**
Zeughausstrasse 43, 8004 Zurich, Switzerland



S Schweizerischer Kalibrierdienst
C Service suisse d'étalonnage
S Servizio svizzero di taratura
S Swiss Calibration Service

Accredited by the Swiss Accreditation Service (SAS)
The Swiss Accreditation Service is one of the signatories to the EA
Multilateral Agreement for the recognition of calibration certificates

Accreditation No.: **SCS 0108**

Client **Anbotek (Auden)**

Certificate No: **D5GHzV2-1160_Oct11**

CALIBRATION CERTIFICATE

Object **D5GHzV2 - SN: 1160**

Calibration procedure(s) **QA CAL-22.v2
Calibration procedure for dipole validation kits between 3-6 GHz**

Calibration date: **October 02, 2021**

This calibration certificate documents the traceability to national standards, which realize the physical units of measurements (SI).
The measurements and the uncertainties with confidence probability are given on the following pages and are part of the certificate.

All calibrations have been conducted in the closed laboratory facility: environment temperature (22 ± 3)°C and humidity < 70%.

Calibration Equipment used (M&TE critical for calibration)

Primary Standards	ID #	Cal Date (Certificate No.)	Scheduled Calibration
Power meter EPM-442A	GB37480704	07-Oct-17 (No. 217-02020)	Oct-15
Power sensor HP 8481A	US37292783	07-Oct-20 (No. 217-02020)	Oct-15
Power sensor HP 8481A	MY41092317	07-Oct-20 (No. 217-02021)	Oct-15
Reference 20 dB Attenuator	SN: 5058 (20k)	01-Apr-21 (No. 217-02131)	Mar-16
Type-N mismatch combination	SN: 5047.2 / 06327	01-Apr-21 (No. 217-02134)	Mar-16
Reference Probe EX3DV4	SN: 3503	30-Dec-20 (No. EX3-3503_Dec14)	Dec-15
DAE4	SN: 601	17-Aug-21 (No. DAE4-601_Aug15)	Aug-16
Secondary Standards	ID #	Check Date (in house)	Scheduled Check
RF generator R&S SMT-06	100972	18-Jun-21 (in house check Jun-15)	In house check: Jun-18
Network Analyzer HP 8753E	US37390585 S4206	15-Oct-20 (in house check Oct-14)	In house check: Oct-15

Calibrated by: **Name: Leif Klynsner, Function: Laboratory Technician**

Approved by: **Name: Katja Pokovic, Function: Technical Manager**

Signature
Leif Klynsner
Katja Pokovic

Issued: October 6, 2021

This calibration certificate shall not be reproduced except in full without written approval of the laboratory.



Calibration Laboratory of

Schmid & Partner

Engineering AG

Zeughausstrasse 43, 8004 Zurich, Switzerland



S Schweizerischer Kalibrierdienst
C Service suisse d'étalonnage
S Servizio svizzero di taratura
S Swiss Calibration Service

Accredited by the Swiss Accreditation Service (SAS)

Accreditation No.: **SCS 0108**

The Swiss Accreditation Service is one of the signatories to the EA Multilateral Agreement for the recognition of calibration certificates

Glossary:

TSL	tissue simulating liquid
ConvF	sensitivity in TSL / NORM x,y,z
N/A	not applicable or not measured

Calibration is Performed According to the Following Standards:

- IEEE Std 1528-2013, "IEEE Recommended Practice for Determining the Peak Spatial-Averaged Specific Absorption Rate (SAR) in the Human Head from Wireless Communications Devices: Measurement Techniques", June 2013
- IEC 62209-2, "Procedure to determine the Specific Absorption Rate (SAR) for wireless communication devices used in close proximity to the human body (frequency range of 30 MHz to 6 GHz)", March 2010
- KDB 865664, "SAR Measurement Requirements for 100 MHz to 6 GHz"

Additional Documentation:

- DASY4/5 System Handbook

Methods Applied and Interpretation of Parameters:

- Measurement Conditions:** Further details are available from the Validation Report at the end of the certificate. All figures stated in the certificate are valid at the frequency indicated.
- Antenna Parameters with TSL:** The dipole is mounted with the spacer to position its feed point exactly below the center marking of the flat phantom section, with the arms oriented parallel to the body axis.
- Feed Point Impedance and Return Loss:** These parameters are measured with the dipole positioned under the liquid filled phantom. The impedance stated is transformed from the measurement at the SMA connector to the feed point. The Return Loss ensures low reflected power. No uncertainty required.
- Electrical Delay:** One-way delay between the SMA connector and the antenna feed point. No uncertainty required.
- SAR measured:** SAR measured at the stated antenna input power.
- SAR normalized:** SAR as measured, normalized to an input power of 1 W at the antenna connector.
- SAR for nominal TSL parameters:** The measured TSL parameters are used to calculate the nominal SAR result.

The reported uncertainty of measurement is stated as the standard uncertainty of measurement multiplied by the coverage factor $k=2$, which for a normal distribution corresponds to a coverage probability of approximately 95%.



Measurement Conditions

DASY system configuration, as far as not given on page 1.

DASY Version	DASY5	V52.8.8
Extrapolation	Advanced Extrapolation	
Phantom	Modular Flat Phantom V5.0	
Distance Dipole Center - TSL	10 mm	with Spacer
Zoom Scan Resolution	dx, dy = 4.0 mm, dz = 1.4 mm	Graded Ratio = 1.4 (Z direction)
Frequency	5200 MHz ± 1 MHz 5300 MHz ± 1 MHz 5600 MHz ± 1 MHz 5800 MHz ± 1 MHz	

Head TSL parameters at 5200 MHz

The following parameters and calculations were applied.

	Temperature	Permittivity	Conductivity
Nominal Head TSL parameters	22.0 °C	36.0	4.66 mho/m
Measured Head TSL parameters	(22.0 ± 0.2) °C	36.4 ± 6 %	4.57 mho/m ± 6 %
Head TSL temperature change during test	< 0.5 °C	----	----

SAR result with Head TSL at 5200 MHz

SAR averaged over 1 cm ³ (1 g) of Head TSL	Condition	
SAR measured	100 mW input power	8.06 W/kg
SAR for nominal Head TSL parameters	normalized to 1W	80.7 W/kg ± 19.9 % (k=2)

SAR averaged over 10 cm ³ (10 g) of Head TSL	condition	
SAR measured	100 mW input power	2.31 W/kg
SAR for nominal Head TSL parameters	normalized to 1W	23.1 W/kg ± 19.5 % (k=2)



Head TSL parameters at 5300 MHz

The following parameters and calculations were applied.

	Temperature	Permittivity	Conductivity
Nominal Head TSL parameters	22.0 °C	35.9	4.76 mho/m
Measured Head TSL parameters	(22.0 ± 0.2) °C	36.2 ± 6 %	4.68 mho/m ± 6 %
Head TSL temperature change during test	< 0.5 °C	----	----

SAR result with Head TSL at 5300 MHz

SAR averaged over 1 cm ³ (1 g) of Head TSL	Condition	
SAR measured	100 mW input power	8.26 W/kg
SAR for nominal Head TSL parameters	normalized to 1W	82.7 W / kg ± 19.9 % (k=2)

SAR averaged over 10 cm ³ (10 g) of Head TSL	condition	
SAR measured	100 mW input power	2.39 W/kg
SAR for nominal Head TSL parameters	normalized to 1W	23.9 W/kg ± 19.5 % (k=2)

Head TSL parameters at 5600 MHz

The following parameters and calculations were applied.

	Temperature	Permittivity	Conductivity
Nominal Head TSL parameters	22.0 °C	35.5	5.07 mho/m
Measured Head TSL parameters	(22.0 ± 0.2) °C	35.7 ± 6 %	5.03 mho/m ± 6 %
Head TSL temperature change during test	< 0.5 °C	----	----

SAR result with Head TSL at 5600 MHz

SAR averaged over 1 cm ³ (1 g) of Head TSL	Condition	
SAR measured	100 mW input power	8.69 W/kg
SAR for nominal Head TSL parameters	normalized to 1W	87.0 W/kg ± 19.9 % (k=2)

SAR averaged over 10 cm ³ (10 g) of Head TSL	condition	
SAR measured	100 mW input power	2.47 W/kg
SAR for nominal Head TSL parameters	normalized to 1W	24.7 W/kg ± 19.5 % (k=2)



Head TSL parameters at 5800 MHz

The following parameters and calculations were applied.

	Temperature	Permittivity	Conductivity
Nominal Head TSL parameters	22.0 °C	35.3	5.27 mho/m
Measured Head TSL parameters	(22.0 ± 0.2) °C	35.3 ± 6 %	5.26 mho/m ± 6 %
Head TSL temperature change during test	< 0.5 °C	----	----

SAR result with Head TSL at 5800 MHz

SAR averaged over 1 cm ³ (1 g) of Head TSL	Condition	
SAR measured	100 mW input power	8.20 W/kg
SAR for nominal Head TSL parameters	normalized to 1W	82.0 W/kg ± 19.9 % (k=2)

SAR averaged over 10 cm ³ (10 g) of Head TSL	condition	
SAR measured	100 mW input power	2.31 W/kg
SAR for nominal Head TSL parameters	normalized to 1W	23.1 W/kg ± 19.5 % (k=2)



Body TSL parameters at 5200 MHz

The following parameters and calculations were applied.

	Temperature	Permittivity	Conductivity
Nominal Body TSL parameters	22.0 °C	49.0	5.30 mho/m
Measured Body TSL parameters	(22.0 ± 0.2) °C	47.9 ± 6 %	5.35 mho/m ± 6 %
Body TSL temperature change during test	< 0.5 °C	----	----

SAR result with Body TSL at 5200 MHz

SAR averaged over 1 cm ³ (1 g) of Body TSL	Condition	
SAR measured	100 mW input power	7.81 W/kg
SAR for nominal Body TSL parameters	normalized to 1W	77.8 W/kg ± 19.9 % (k=2)

SAR averaged over 10 cm ³ (10 g) of Body TSL	condition	
SAR measured	100 mW input power	2.18 W/kg
SAR for nominal Body TSL parameters	normalized to 1W	21.7 W/kg ± 19.5 % (k=2)

Body TSL parameters at 5300 MHz

The following parameters and calculations were applied.

	Temperature	Permittivity	Conductivity
Nominal Body TSL parameters	22.0 °C	48.9	5.42 mho/m
Measured Body TSL parameters	(22.0 ± 0.2) °C	47.7 ± 6 %	5.49 mho/m ± 6 %
Body TSL temperature change during test	< 0.5 °C	----	----

SAR result with Body TSL at 5300 MHz

SAR averaged over 1 cm ³ (1 g) of Body TSL	Condition	
SAR measured	100 mW input power	7.88 W/kg
SAR for nominal Body TSL parameters	normalized to 1W	78.4 W/kg ± 19.9 % (k=2)

SAR averaged over 10 cm ³ (10 g) of Body TSL	condition	
SAR measured	100 mW input power	2.20 W/kg
SAR for nominal Body TSL parameters	normalized to 1W	21.9 W/kg ± 19.5 % (k=2)



Body TSL parameters at 5600 MHz

The following parameters and calculations were applied.

	Temperature	Permittivity	Conductivity
Nominal Body TSL parameters	22.0 °C	48.5	5.77 mho/m
Measured Body TSL parameters	(22.0 ± 0.2) °C	46.7 ± 6 %	5.99 mho/m ± 6 %
Body TSL temperature change during test	< 0.5 °C	----	----

SAR result with Body TSL at 5600 MHz

SAR averaged over 1 cm ³ (1 g) of Body TSL	Condition	
SAR measured	100 mW input power	8.20 W/kg
SAR for nominal Body TSL parameters	normalized to 1W	81.5 W/kg ± 19.9 % (k=2)

SAR averaged over 10 cm ³ (10 g) of Body TSL	condition	
SAR measured	100 mW input power	2.30 W/kg
SAR for nominal Body TSL parameters	normalized to 1W	22.8 W/kg ± 19.5 % (k=2)

Body TSL parameters at 5800 MHz

The following parameters and calculations were applied.

	Temperature	Permittivity	Conductivity
Nominal Body TSL parameters	22.0 °C	48.2	6.00 mho/m
Measured Body TSL parameters	(22.0 ± 0.2) °C	46.4 ± 6 %	6.27 mho/m ± 6 %
Body TSL temperature change during test	< 0.5 °C	----	----

SAR result with Body TSL at 5800 MHz

SAR averaged over 1 cm ³ (1 g) of Body TSL	Condition	
SAR measured	100 mW input power	7.88 W/kg
SAR for nominal Body TSL parameters	normalized to 1W	78.3 W/kg ± 19.9 % (k=2)

SAR averaged over 10 cm ³ (10 g) of Body TSL	condition	
SAR measured	100 mW input power	2.20 W/kg
SAR for nominal Body TSL parameters	normalized to 1W	21.8 W/kg ± 19.5 % (k=2)



Appendix (Additional assessments outside the scope of SCS 0108)**Antenna Parameters with Head TSL at 5200 MHz**

Impedance, transformed to feed point	48.1 Ω - 8.5 $\mu\Omega$
Return Loss	- 21.0 dB

Antenna Parameters with Head TSL at 5300 MHz

Impedance, transformed to feed point	50.2 Ω - 5.2 $\mu\Omega$
Return Loss	- 25.7 dB

Antenna Parameters with Head TSL at 5600 MHz

Impedance, transformed to feed point	54.8 Ω - 2.5 $\mu\Omega$
Return Loss	- 25.7 dB

Antenna Parameters with Head TSL at 5800 MHz

Impedance, transformed to feed point	53.0 Ω - 3.0 $\mu\Omega$
Return Loss	- 27.7 dB



Antenna Parameters with Body TSL at 5200 MHz

Impedance, transformed to feed point	48.6 Ω - 6.8 $j\Omega$
Return Loss	- 23.0 dB

Antenna Parameters with Body TSL at 5300 MHz

Impedance, transformed to feed point	49.0 Ω - 4.2 $j\Omega$
Return Loss	- 27.1 dB

Antenna Parameters with Body TSL at 5600 MHz

Impedance, transformed to feed point	56.2 Ω - 0.7 $j\Omega$
Return Loss	- 24.6 dB

Antenna Parameters with Body TSL at 5800 MHz

Impedance, transformed to feed point	55.9 Ω - 1.7 $j\Omega$
Return Loss	- 24.8 dB

General Antenna Parameters and Design

Electrical Delay (one direction)	1.199 ns
----------------------------------	----------

After long term use with 100W radiated power, only a slight warming of the dipole near the feedpoint can be measured.

The dipole is made of standard semirigid coaxial cable. The center conductor of the feeding line is directly connected to the second arm of the dipole. The antenna is therefore short-circuited for DC-signals. On some of the dipoles, small end caps are added to the dipole arms in order to improve matching when loaded according to the position as explained in the "Measurement Conditions" paragraph. The SAR data are not affected by this change. The overall dipole length is still according to the Standard.

No excessive force must be applied to the dipole arms, because they might bend or the soldered connections near the feedpoint may be damaged.

Additional EUT Data

Manufactured by	SPEAG
Manufactured on	June 06, 2013



DASY5 Validation Report for Head TSL

Date: 24.09.2021

Test Laboratory: SPEAG, Zurich, Switzerland

DUT: Dipole 5GHz; Type: D5GHzV2; Serial: D5GHzV2 - SN: 1160

Communication System: UID 0 - CW; Frequency: 5200 MHz, Frequency: 5300 MHz, Frequency: 5600 MHz, Frequency: 5800 MHz

Medium parameters used: $f = 5200$ MHz; $\sigma = 4.57$ S/m; $\epsilon_r = 36.4$; $\rho = 1000$ kg/m³, Medium parameters used: $f = 5300$ MHz; $\sigma = 4.68$ S/m; $\epsilon_r = 36.2$; $\rho = 1000$ kg/m³, Medium parameters used: $f = 5600$ MHz; $\sigma = 5.03$ S/m; $\epsilon_r = 35.7$; $\rho = 1000$ kg/m³, Medium parameters used: $f = 5800$ MHz; $\sigma = 5.26$ S/m; $\epsilon_r = 35.3$; $\rho = 1000$ kg/m³

Phantom section: Flat Section

Measurement Standard: DASY5 (IEEE/IEC/ANSI C63.19-2011)

DASY52 Configuration:

- Probe: EX3DV4 - SN3503; ConvF(5.51, 5.51, 5.51); Calibrated: 30.12.2021, ConvF(5.21, 5.21, 5.21); Calibrated: 30.12.2021, ConvF(4.92, 4.92, 4.92); Calibrated: 30.12.2021, ConvF(4.9, 4.9, 4.9); Calibrated: 30.12.2021,
- Sensor-Surface: 1.4mm (Mechanical Surface Detection)
- Electronics: DAE4 Sn601; Calibrated: 17.08.2021
- Phantom: Flat Phantom 5.0 (front); Type: QD000P50AA; Serial: 1001
- DASY52 52.8.8(1222); SEMCAD X 14.6.10(7331)

Dipole Calibration for Head Tissue/Pin=100mW, dist=10mm, f=5200 MHz/Zoom Scan,**dist=1.4mm (8x8x7)/Cube 0:** Measurement grid: dx=4mm, dy=4mm, dz=1.4mm

Reference Value = 64.41 V/m; Power Drift = 0.08 dB

Peak SAR (extrapolated) = 29.3 W/kg

SAR(1 g) = 8.06 W/kg; SAR(10 g) = 2.31 W/kg

Maximum value of SAR (measured) = 18.7 W/kg

Dipole Calibration for Head Tissue/Pin=100mW, dist=10mm, f=5300 MHz/Zoom Scan,**dist=1.4mm (8x8x7)/Cube 0:** Measurement grid: dx=4mm, dy=4mm, dz=1.4mm

Reference Value = 65.31 V/m; Power Drift = 0.05 dB

Peak SAR (extrapolated) = 31.1 W/kg

SAR(1 g) = 8.26 W/kg; SAR(10 g) = 2.39 W/kg

Maximum value of SAR (measured) = 19.4 W/kg

Dipole Calibration for Head Tissue/Pin=100mW, dist=10mm, f=5600 MHz/Zoom Scan,**dist=1.4mm (8x8x7)/Cube 0:** Measurement grid: dx=4mm, dy=4mm, dz=1.4mm

Reference Value = 65.34 V/m; Power Drift = 0.03 dB

Peak SAR (extrapolated) = 34.7 W/kg

SAR(1 g) = 8.69 W/kg; SAR(10 g) = 2.47 W/kg

Maximum value of SAR (measured) = 21.0 W/kg



Dipole Calibration for Head Tissue/Pin=100mW, dist=10mm, f=5800 MHz/Zoom Scan,

dist=1.4mm (8x8x7)/Cube 0: Measurement grid: dx=4mm, dy=4mm, dz=1.4mm

Reference Value = 62.41 V/m; Power Drift = 0.03 dB

Peak SAR (extrapolated) = 34.5 W/kg

SAR(1 g) = 8.2 W/kg; SAR(10 g) = 2.31 W/kg

Maximum value of SAR (measured) = 20.5 W/kg

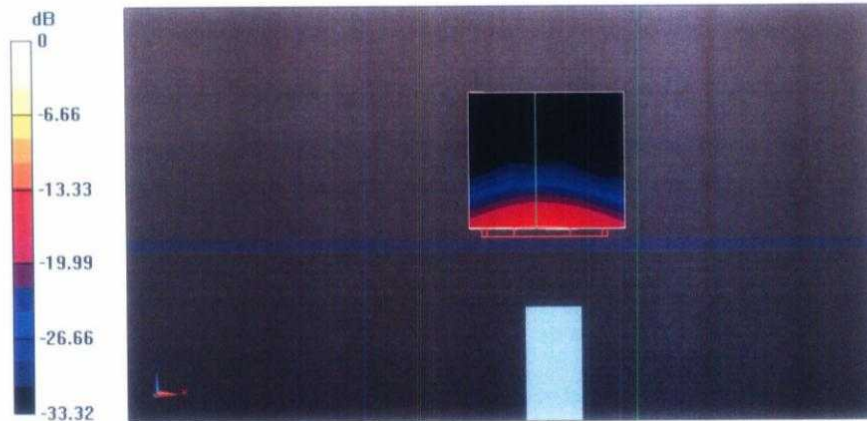

0 dB = 18.7 W/kg = 12.72 dBW/kg



Impedance Measurement Plot for Head TSL

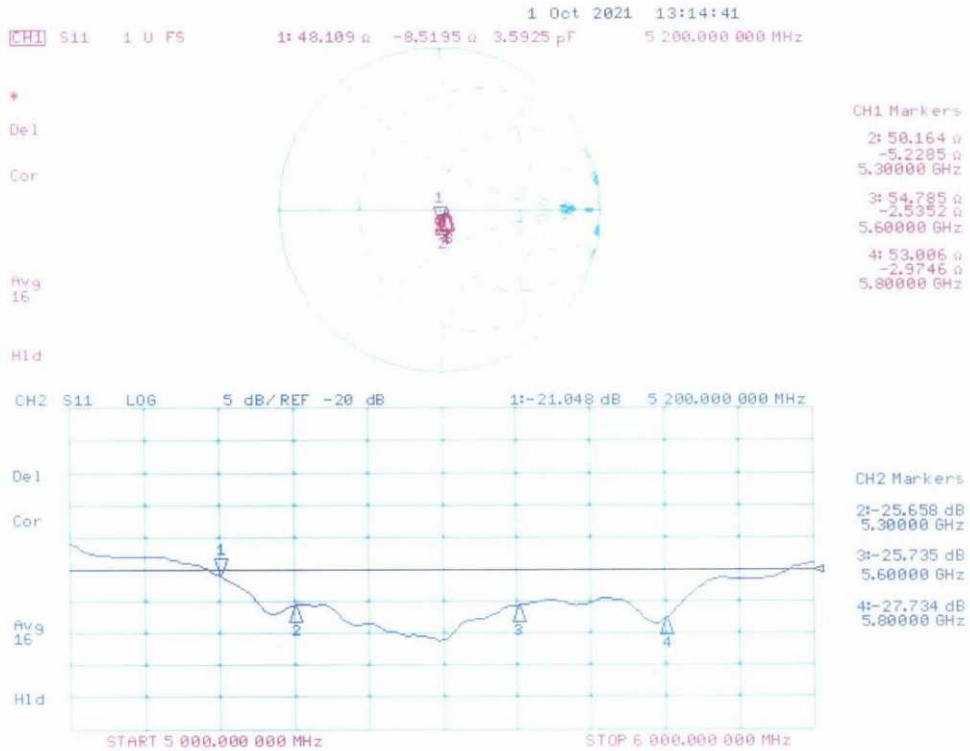

DASY5 Validation Report for Body TSL

Date: 05.10.2021

Test Laboratory: SPEAG, Zurich, Switzerland

DUT: Dipole 5GHz; Type: D5GHZV2; Serial: D5GHZV2 - SN: 1160

Communication System: UID 0 - CW; Frequency: 5200 MHz, Frequency: 5300 MHz, Frequency: 5600 MHz, Frequency: 5800 MHz

Medium parameters used: $f = 5200$ MHz; $\sigma = 5.35$ S/m; $\epsilon_r = 47.9$; $\rho = 1000$ kg/m³, Medium parameters used: $f = 5300$ MHz; $\sigma = 5.49$ S/m; $\epsilon_r = 47.7$; $\rho = 1000$ kg/m³, Medium parameters used: $f = 5600$ MHz; $\sigma = 5.99$ S/m; $\epsilon_r = 46.7$; $\rho = 1000$ kg/m³, Medium parameters used: $f = 5800$ MHz; $\sigma = 6.27$ S/m; $\epsilon_r = 46.4$; $\rho = 1000$ kg/m³

Phantom section: Flat Section

Measurement Standard: DASY5 (IEEE/IEC/ANSI C63.19-2011)

DASY52 Configuration:

- Probe: EX3DV4 - SN3503; ConvF(4.95, 4.95, 4.95); Calibrated: 30.12.2021, ConvF(4.78, 4.78, 4.78); Calibrated: 30.12.2021; ConvF(4.35, 4.35, 4.35); Calibrated: 30.12.2021, ConvF(4.32, 4.32, 4.32); Calibrated: 30.12.2021;
- Sensor-Surface: 1.4mm (Mechanical Surface Detection)
- Electronics: DAE4 Sn601; Calibrated: 17.08.2021
- Phantom: Flat Phantom 5.0 (back); Type: QD000P50AA; Serial: 1002
- DASY52 52.8.8(1222); SEMCAD X 14.6.10(7331)

Dipole Calibration for Body Tissue/Pin=100mW, dist=10mm, f=5200 MHz/Zoom Scan, dist=1.4mm (8x8x7)/Cube 0: Measurement grid: dx=4mm, dy=4mm, dz=1.4mm
Reference Value = 67.32 V/m; Power Drift = -0.04 dB
Peak SAR (extrapolated) = 30.4 W/kg
SAR(1 g) = 7.81 W/kg; SAR(10 g) = 2.18 W/kg
Maximum value of SAR (measured) = 18.2 W/kg

Dipole Calibration for Body Tissue/Pin=100mW, dist=10mm, f=5300 MHz/Zoom Scan, dist=1.4mm (8x8x7)/Cube 0: Measurement grid: dx=4mm, dy=4mm, dz=1.4mm
Reference Value = 67.22 V/m; Power Drift = -0.06 dB
Peak SAR (extrapolated) = 31.6 W/kg
SAR(1 g) = 7.88 W/kg; SAR(10 g) = 2.2 W/kg
Maximum value of SAR (measured) = 18.8 W/kg

Dipole Calibration for Body Tissue/Pin=100mW, dist=10mm, f=5600 MHz/Zoom Scan, dist=1.4mm (8x8x7)/Cube 0: Measurement grid: dx=4mm, dy=4mm, dz=1.4mm
Reference Value = 67.36 V/m; Power Drift = -0.03 dB
Peak SAR (extrapolated) = 36.6 W/kg
SAR(1 g) = 8.2 W/kg; SAR(10 g) = 2.3 W/kg
Maximum value of SAR (measured) = 20.2 W/kg



Dipole Calibration for Body Tissue/Pin=100mW, dist=10mm, f=5800 MHz/Zoom Scan,
dist=1.4mm (8x8x7)/Cube 0: Measurement grid: dx=4mm, dy=4mm, dz=1.4mm
Reference Value = 65.22 V/m; Power Drift = -0.03 dB
Peak SAR (extrapolated) = 37.1 W/kg
SAR(1 g) = 7.88 W/kg; SAR(10 g) = 2.2 W/kg
Maximum value of SAR (measured) = 19.7 W/kg

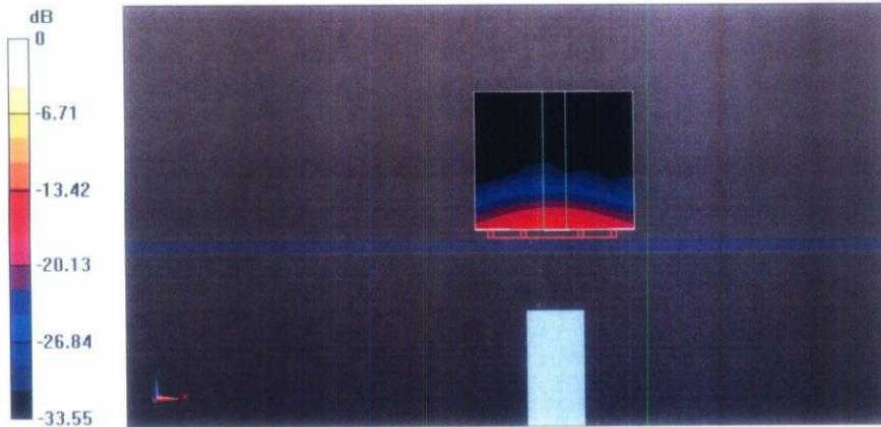

0 dB = 18.2 W/kg = 12.60 dBW/kg



Impedance Measurement Plot for Body TSL

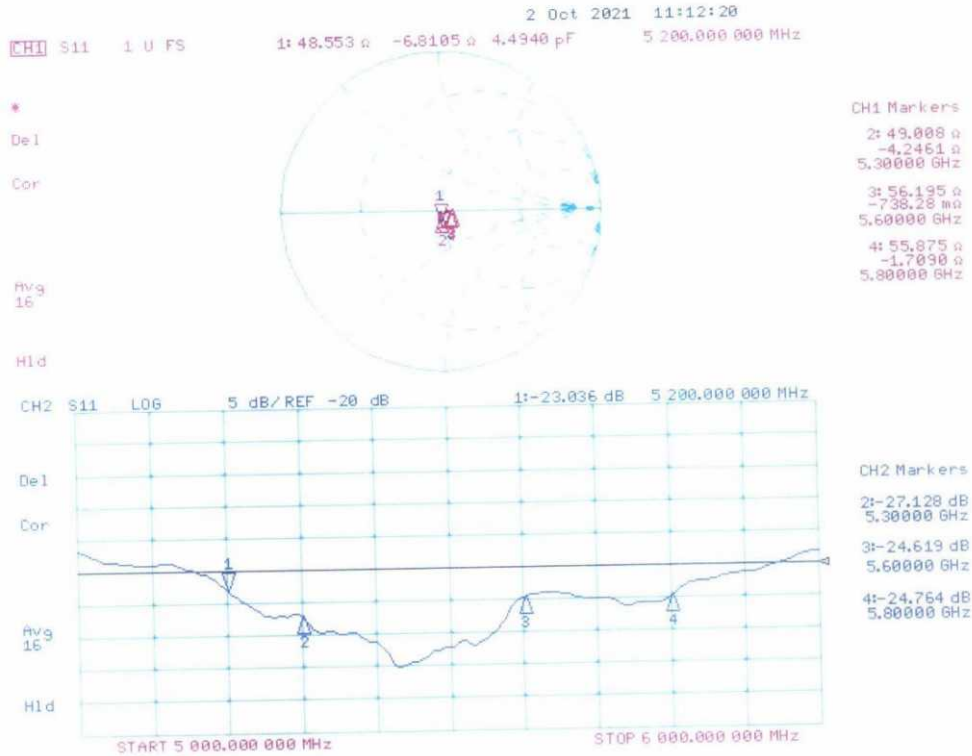

Extended Dipole Calibrations

Referring to KDB865664 D01, if dipoles are verified in return loss (<-20dB, within 20% of prior calibration), and in impedance (within 5 ohm of prior calibration), the annual calibration is not necessary and the calibration interval can be extended.

Head-2450						
Date of measurement	Return-loss (dB)	Delta (%)	Real Impedance (ohm)	Delta (ohm)	Imaginary impedance (ohm)	Delta (ohm)
2021-06-21	-25.88		54.65		2.81	
2022-06-21	-26.12	0.93	54.79	0.14	2.94	0.13
2023-06-21	-26.15	1.04	54.88	0.23	3.05	0.24

Body-2450						
Date of measurement	Return-loss (dB)	Delta (%)	Real Impedance (ohm)	Delta (ohm)	Imaginary impedance (ohm)	Delta (ohm)
2021-06-21	-27.36		50.75		4.29	
2022-06-21	-27.68	1.17	51.38	0.63	4.66	0.37
2023-06-21	-27.89	1.94	51.67	0.92	4.58	0.29

Head-5200						
Date of measurement	Return-loss (dB)	Delta (%)	Real Impedance (ohm)	Delta (ohm)	Imaginary impedance (ohm)	Delta (ohm)
2021-10-08	-21.05		48.11		-8.52	
2022-10-08	-21.31	1.24	48.37	0.26	-9.78	1.26
2023-10-08	-21.57	2.47	49.53	1.42	-10.24	1.72

Body-5200						
Date of measurement	Return-loss (dB)	Delta (%)	Real Impedance (ohm)	Delta (ohm)	Imaginary impedance (ohm)	Delta (ohm)
2021-10-08	-23.04		48.55		-6.81	
2022-10-08	-23.41	1.61	48.93	0.38	-7.39	0.58
2023-10-08	-24.12	4.69	49.82	1.27	-6.97	0.16



Head-5300						
Date of measurement	Return-loss (dB)	Delta (%)	Real Impedance (ohm)	Delta (ohm)	Imaginary impedance (ohm)	Delta (ohm)
2021-10-08	-25.66		50.16		-5.23	
2022-10-08	-26.17	1.99	52.23	2.07	-6.11	0.88
2023-10-08	-26.53	3.39	51.86	1.70	-5.88	0.65

Body-5300						
Date of measurement	Return-loss (dB)	Delta (%)	Real Impedance (ohm)	Delta (ohm)	Imaginary impedance (ohm)	Delta (ohm)
2021-10-08	-27.13		49.01		-4.25	
2022-10-08	-27.48	1.29	49.63	0.62	-5.29	1.04
2023-10-08	-28.13	3.69	50.33	1.32	-5.31	1.06

The return loss is <-20dB, within 20% of prior calibration; the impedance is within 5ohm of prior calibration. Therefore the verification result should support extended calibration.

*****END OF REPORT*****

