



FCC 47 CFR PART 15 SUBPART C

TEST REPORT

For

DBScar

Model: DBScar-DI Adapter, DBScar-CI Adapter

Brand: LAUNCH

Test Report Number:

C121019Z01-RP1

Prepared for

Launch Tech Co., Ltd.

**Launch Industrial Park, North of Wuhe Rd., Banxuegang, Longgang,
Shenzhen, China**

Prepared by

COMPLIANCE CERTIFICATION SERVICES (SHENZHEN) INC.

**No.10-1, Mingkeda Logistics Park, No.18, Huanguan South Rd.,
Guan Lan Town, Baoan District, Shenzhen China**

TEL: 86-755-28055000

FAX: 86-755-28055221

Issued Date: November 7,2012



TESTING CERT #2861.01

Note: This report shall not be reproduced except in full, without the written approval of Compliance Certification Services Inc. This document may be altered or revised by Compliance Certification Services Inc. personnel only, and shall be noted in the revision section of the document. The client should not use it to claim product endorsement by TAF, A2LA, NVLAP, NIST or any government agencies. The test result of this report relate only to the tested sample identified in this report.



Revision History

Rev.	Issue No.	Revisions	Effect Page	Revised By
00	C121019Z01-RP1	Initial Issue	ALL	Anna Liu



TABLE OF CONTENTS

1. TEST RESULT CERTIFICATION4

2. EUT DESCRIPTION.....5

3. TEST METHODOLOGY.....6

 3.1 DESCRIPTION OF TEST MODES.....6

4. FACILITIES AND ACCREDITATIONS7

 4.1 FACILITIES.....7

 4.2 ACCREDITATIONS.....7

 4.3 MEASUREMENT UNCERTAINTY7

5. SETUP OF EQUIPMENT UNDER TEST8

 5.1 SETUP CONFIGURATION OF EUT8

 5.2 SUPPORT EQUIPMENT8

6. FCC PART 15.247 REQUIREMENTS9

 6.1 20dB BANDWIDTH.....9

 6.2 PEAK POWER.....14

 6.3 PEAK POWER SPECTRAL DENSITY15

 6.4 BAND EDGES MEASUREMENT17

 6.5 FREQUENCY SEPARATION27

 6.6 NUMBER OF HOPPING FREQUENCY30

 6.7 TIME OF OCCUPANCY (DWELL TIME).....33

 6.8 SPURIOUS EMISSIONS.....40

 6.9 POWERLINE CONDUCTED EMISSIONS58



1. TEST RESULT CERTIFICATION

Product:	DBScar
Model:	DBScar-DI Adapter, DBScar-CI Adapter
Brand:	LAUNCH
Tested:	October 19~November 7,2012
Applicant:	Launch Tech Co., Ltd. Launch Industrial Park, North of Wuhe Rd., Banxuegang, Longgang, Shenzhen, China
Manufacturer:	Launch Tech Co., Ltd. Launch Industrial Park, North of Wuhe Rd., Banxuegang, Longgang, Shenzhen, China

APPLICABLE STANDARDS	
STANDARD	TEST RESULT
FCC 47 CFR Part 15 Subpart C	No non-compliance noted

We hereby certify that:

The above equipment was tested by Compliance Certification Services Inc. The test data, data evaluation, test procedures, and equipment configurations shown in this report were made in accordance with the procedures given in ANSI C63.4:2009 and the energy emitted by the sample EUT tested as described in this report is in compliance with conducted and radiated emission limits of FCC Rules Part 15.207, 15.209 and 15.247.

The test results of this report relate only to the tested sample EUT identified in this report.

Approved by:

Tom Gan
Supervisor of EMC Dept.
Compliance Certification Service Inc.

Reviewed by:

Ruby Zhang
Supervisor of Report Dept.
Compliance Certification Service Inc.



2. EUT DESCRIPTION

Product	DBScar
Model Number	DBScar-DI Adapter, DBScar-CI Adapter
Brand	LAUNCH
Model Discrepancy	Just their model color was different. DBScar-DI Adapter is white and DBScar-CI Adapter is red.
Identify Number	C121019Z01-RP1
Power Supply	DC12V supplied by DC Power
Received Date	October 19,2012
Frequency Range	2402 ~ 2480 MHz
Transmit Power	GFSK : -1.30dBm 8DPSK :-1.89dBm
Modulation Technique	FHSS (GFSK for 1Mbps, $\pi/4$ -DQPSK for 2Mbps, 8DPSK for 3Mbps)
Number of Channels	79 Channels
Antenna Specification	Multilayer Ceramic Antenna with 2dBi gain(Max)
Temperature Range	-40°C ~ +85°C

Note: This submittal(s) (test report) is intended for FCC ID: XUJDBSCARI filing to comply with Section 15.207, 15.209 and 15.247 of the FCC Part 15, Subpart C Rules.



3. TEST METHODOLOGY

3.1 DESCRIPTION OF TEST MODES

The EUT has been tested under operating condition.

Test program used to control the EUT for staying in continuous transmitting and receiving mode is programmed.

The following test mode(s) were scanned during the preliminary test below 1G:

Test Item	Test mode	Worse mode
Conducted Emission	Not applicable, since the EUT powered by DC power.	
Radiated Emission	Mode 1: TX	<input checked="" type="checkbox"/>

Above 1G, Channel Low (2402MHz) · Mid (2441MHz) and High (2480MHz) were chosen for full testing for GFSK and 8DPSK.



4. FACILITIES AND ACCREDITATIONS

4.1 FACILITIES

All measurement facilities used to collect the measurement data are located at

**No.10-1, Mingkeda Logistics Park, No.18, Huanguan South Rd.,
Guan Lan Town, Baoan District, Shenzhen, China**

The sites are constructed in conformance with the requirements of ANSI C63.4:2009, ANSI C63.7 and CISPR Publication 22. All receiving equipment conforms to CISPR Publication 16-1, "Radio Interference Measuring Apparatus and Measurement Methods."

4.2 ACCREDITATIONS

Our laboratories are accredited and approved by the following accreditation body according to ISO/IEC 17025.

USA	A2LA
China	CNAS

The measuring facility of laboratories has been authorized or registered by the following approval agencies.

USA	FCC
Japan	VCCI(C-3478, R-3135, T-652)
Canada	INDUSTRY CANADA
Taiwan	BSMI
Norway	Nemko

Copies of granted accreditation certificates are available for downloading from our web site, <http://www.ccsrf.com>

4.3 MEASUREMENT UNCERTAINTY

Where relevant, the following measurement uncertainty levels have been estimated for tests performed on the EUT as specified in CISPR 16-4-2:

Measurement	Frequency	Uncertainty
Conducted emissions	9kHz~30MHz	+/- 3.18dB
Radiated emissions	30MHz ~ 200MHz	+/- 3.79dB
	200MHz ~1000MHz	+/- 3.62dB
	Above 1000MHz	+/- 5.04dB
Band Edges	+/-0.182 dB	

This uncertainty represents an expanded uncertainty expressed at approximately the 95% confidence level using a coverage factor of k=2.

The measured result is above (below) the specification limit by a margin less than the measurement uncertainty; it is therefore not possible to state compliance based on the 95% level of confidence. However, the result indicates that compliance (non-compliance) is more probable than non-compliance) with the specification limit.



5. SETUP OF EQUIPMENT UNDER TEST

5.1 SETUP CONFIGURATION OF EUT

See test photographs attached in Appendix 1 for the actual connections between EUT and support equipment.

5.2 SUPPORT EQUIPMENT

No.	Equipment	Model No.	Serial No.	FCC ID	Brand	Data Cable	Power Cord
1	Notebook	PP24L	N/A	N/A	DELL	Shielded 1.50m	Unshielded 1.80m

Notes:

Grounding was established in accordance with the manufacturer's requirements and conditions for the intended use.



6. FCC PART 15.247 REQUIREMENTS

6.1 20dB BANDWIDTH

None; for reporting purpose only.

MEASUREMENT EQUIPMENT USED

Name of Equipment	Manufacturer	Model	Serial Number	Last Calibration	Due Calibration
Spectrum Analyzer	Agilent	E4446A	US44300399	03/19/2012	03/19/2013

Remark: Each piece of equipment is scheduled for calibration once a year.

TEST CONFIGURATION

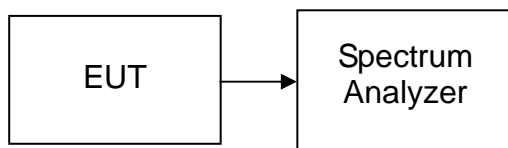

TEST PROCEDURE

1. Place the EUT on the table and set it in the transmitting mode.
2. Remove the antenna from the EUT, then connect a low loss RF cable from antenna port to the spectrum analyzer.
3. Set the spectrum analyzer as RBW=30kHz, VBW=30kHz, Span=3MHz, Sweep = auto.
4. Mark the peak frequency and 20dB (upper and lower) frequency.
5. Repeat until all the test channels are investigated.

TEST RESULTS

No non-compliance noted



Test plot (GFSK)

20dB Bandwidth (CH Low)

Agilent

R T

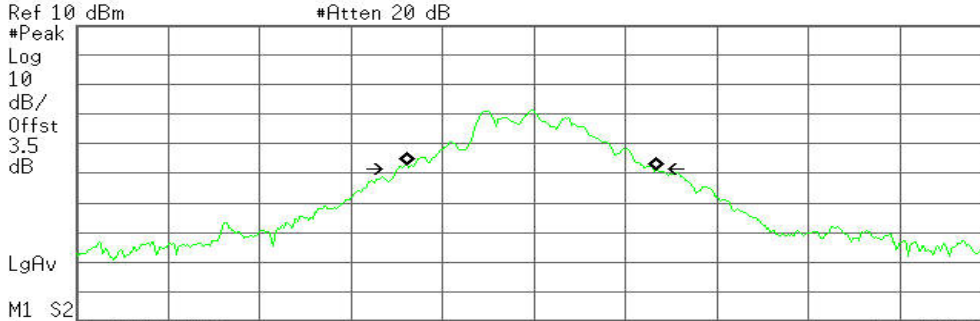

Ref 10 dBm #Atten 20 dB
 #Peak Log 10 dB/Offst 3.5 dB
 LgAv
 M1 S2
 Center 2.402 000 GHz Span 3 MHz
 #Res BW 30 kHz VBW 30 kHz Sweep 4.04 ms (601 pts)

Occupied Bandwidth
 816.8727 kHz

Occ BW % Pwr 99.00 %
 x dB -20.00 dB

Transmit Freq Error -8.845 kHz
 x dB Bandwidth 836.698 kHz

20dB Bandwidth (CH Mid)

Agilent

R T

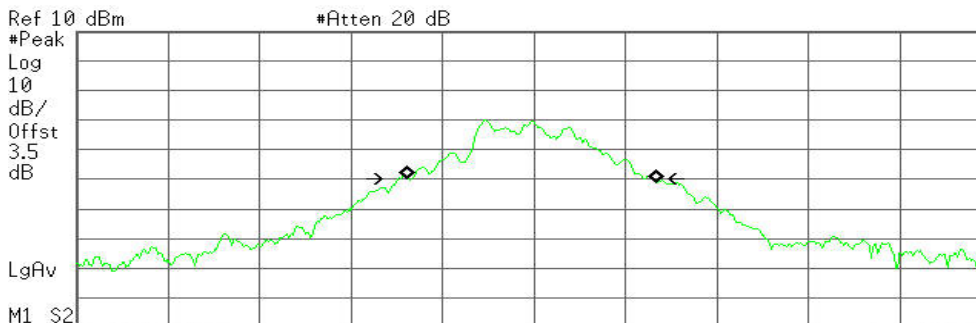

Ref 10 dBm #Atten 20 dB
 #Peak Log 10 dB/Offst 3.5 dB
 LgAv
 M1 S2
 Center 2.441 000 GHz Span 3 MHz
 #Res BW 30 kHz VBW 30 kHz Sweep 4.04 ms (601 pts)

Occupied Bandwidth
 816.3025 kHz

Occ BW % Pwr 99.00 %
 x dB -20.00 dB

Transmit Freq Error -7.444 kHz
 x dB Bandwidth 833.765 kHz



20dB Bandwidth (CH High)

Agilent

R T

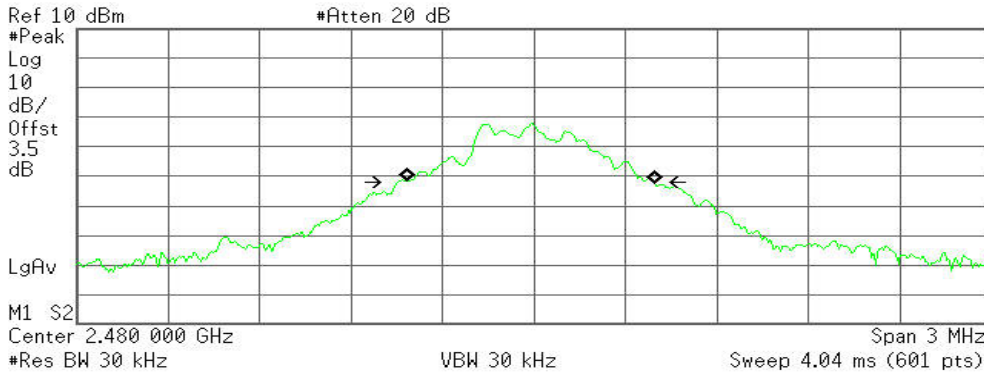

Occupied Bandwidth
812.9556 kHz

Occ BW % Pwr 99.00 %
x dB -20.00 dB

Transmit Freq Error -9.645 kHz
x dB Bandwidth 843.490 kHz



Test plot (8DPSK)

20dB Bandwidth (CH Low)

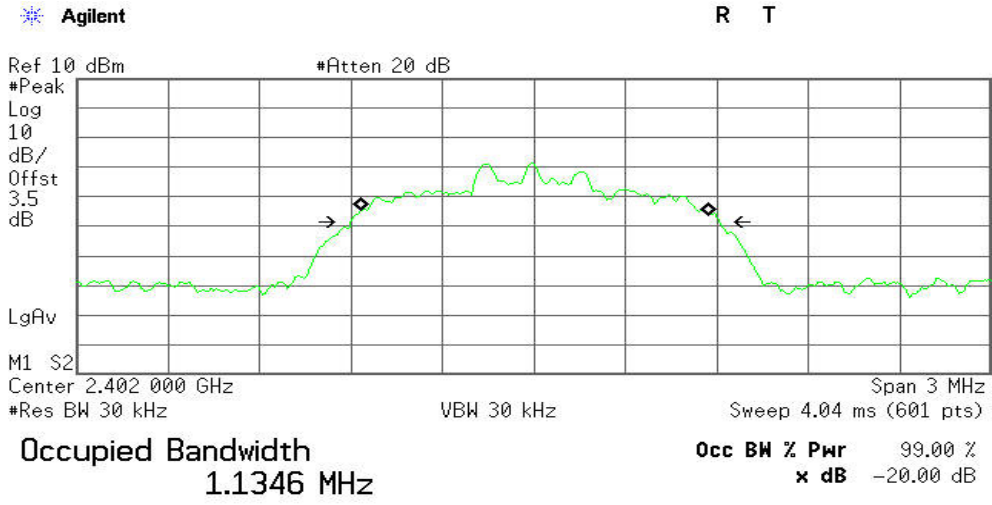

Transmit Freq Error 2.654 kHz
x dB Bandwidth 1.213 MHz

20dB Bandwidth (CH Mid)

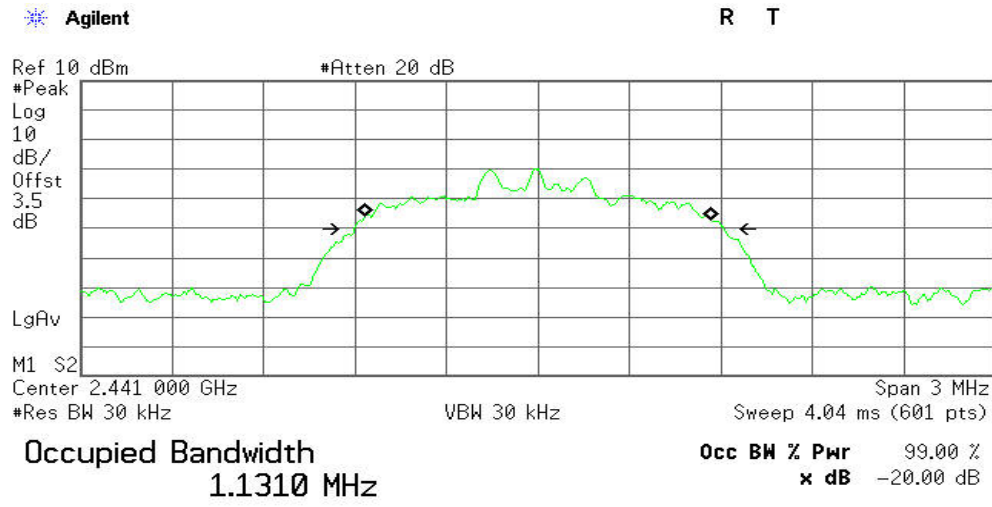

Transmit Freq Error 1.445 kHz
x dB Bandwidth 1.212 MHz



20dB Bandwidth (CH High)

Agilent

R T

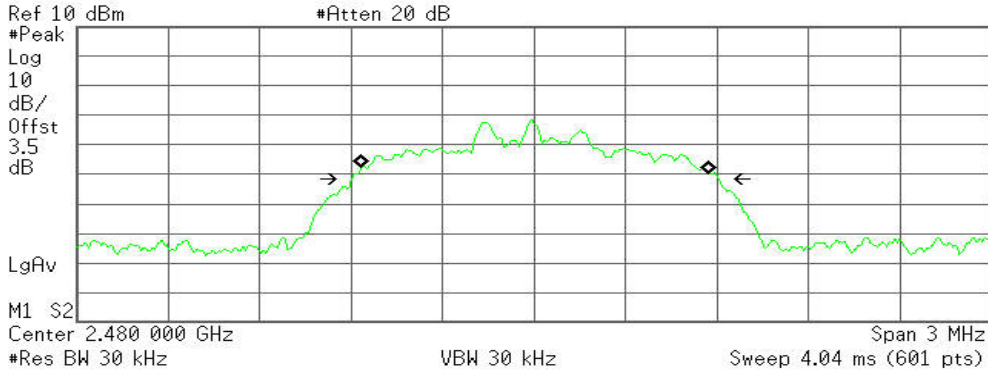

Occupied Bandwidth
1.1314 MHz

Occ BW % Pwr 99.00 %
x dB -20.00 dB

Transmit Freq Error 2.351 kHz
x dB Bandwidth 1.204 MHz



6.2 PEAK POWER

LIMIT

The maximum peak output power of the intentional radiator shall not exceed the following:

1. For frequency hopping systems operating in the 2400-2483.5 MHz band employing at least 75 non-overlapping hopping channels, and all frequency hopping systems in the 5725-5850 MHz band: 1 watt. For all other frequency hopping systems in the 2400-2483.5 MHz band: 0.125 watts.
2. Except as shown in paragraphs (b)(3) (i), (ii) and (iii) of this section, if transmitting antennas of directional gain greater than 6dBi are used the peak output power from the intentional radiator shall be reduced below the stated values in paragraphs (b)(1) or (b)(2) of this section, as appropriate, by the amount in dB that the directional gain of the antenna exceeds 6dBi.
3. The conducted output power limit specified in paragraph (b) of this section is based on the use of antennas with directional gains that do not exceed 6 dBi. Except as shown in paragraph (c) of this section, if transmitting antennas of directional gain greater than 6 dBi are used, the conducted output power from the intentional radiator shall be reduced below the stated values in paragraphs (b)(1), (b)(2), and (b)(3) of this section, as appropriate, by the amount in dB that the directional gain of the antenna exceeds 6 dBi.

MEASUREMENT EQUIPMENT USED

Name of Equipment	Manufacturer	Model	Serial Number	Last Calibration	Due Calibration
Power Meter	Anritsu	ML2487A	6K00001491	03/19/2012	03/19/2013
Spectrum Analyzer	Agilent	E4446A	US44300399	03/19/2012	03/19/2013
Power Sensor	Anritsu	MA2411B	1126150	01/27/2012	01/27/2013

Remark: Each piece of equipment is scheduled for calibration once a year.

Test Configuration

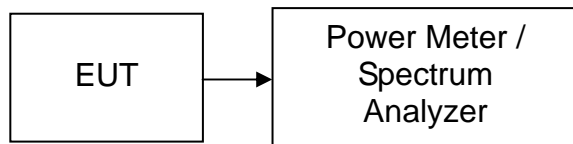

TEST PROCEDURE

The transmitter output is connected to the RF Power Meter. The RF Power Meter is set to the peak power detection.



TEST RESULTS

No non-compliance noted

Test Data

GFSK

Channel	Frequency (MHz)	Reading Power (dBm)	Factor (dB)	Output Power (dBm)	Output Power (W)	Limit (W)	Result
Low	2402	-4.80	3.50	-1.30	0.00074	1	PASS
Mid	2441	-4.94	3.50	-1.44	0.00072		PASS
High	2480	-5.08	3.50	-1.58	0.00070		PASS

8DPSK

Channel	Frequency (MHz)	Reading Power (dBm)	Factor (dB)	Output Power (dBm)	Output Power (W)	Limit (W)	Result
Low	2402	-5.39	3.50	-1.89	0.00065	1	PASS
Mid	2441	-5.41	3.50	-1.91	0.00064		PASS
High	2480	-5.57	3.50	-2.07	0.00062		PASS



6.3 PEAK POWER SPECTRAL DENSITY

LIMIT

1. For direct sequence systems, the peak power spectral density conducted from the intentional radiator to the antenna shall not be greater than 8dBm in any 3kHz band during any time interval of continuous transmission.
2. The direct sequence operating of the hybrid system, with the frequency hopping operation turned off, shall comply with the power density requirements of paragraph (d) of this section.

MEASUREMENT EQUIPMENT USED

Name of Equipment	Manufacturer	Model	Serial Number	Last Calibration	Due Calibration
Spectrum Analyzer	Agilent	E4446A	US44300399	03/19/2012	03/19/2013

Remark: Each piece of equipment is scheduled for calibration once a year.

Test Configuration

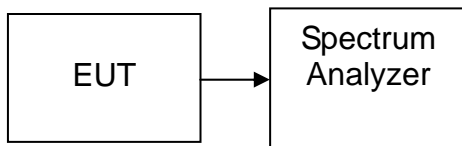

TEST PROCEDURE

1. Place the EUT on the table and set it in transmitting mode.
2. Remove the antenna from the EUT and then connect a low loss RF cable from the antenna port to the spectrum analyzer.
3. Set the spectrum analyzer as RBW = 3kHz, VBW = 10kHz, Span = 300kHz, Sweep=100s
4. Record the max. reading.
5. Repeat the above procedure until the measurements for all frequencies are completed.

TEST RESULTS

Not applicable. Since EUT is the Bluetooth device.



6.4 BAND EDGES MEASUREMENT

LIMIT

According to §15.247(c), in any 100 kHz bandwidth outside the frequency bands in which the spread spectrum intentional radiator is operating, the radio frequency power that is produced by the intentional radiator shall be at least 20dB below that in the 100kHz bandwidth within the band that contains the highest level of the desired power. In addition, radiated emissions which fall in the restricted bands, as defined in §15.205(a), must also comply with the radiated emission limits specified in 15.209(a).

MEASUREMENT EQUIPMENT USED

Radiated Emission Test Site 966(2)					
Name of Equipment	Manufacturer	Model Number	Serial Number	Last Calibration	Due Calibration
PSA Series Spectrum Analyzer	Agilent	E4446A	US44300399	03/19/2012	03/19/2013
ESCI EMI TEST RECEIVER.ESCI	ROHDE&SCHWARZ	ESCI	100783	03/17/2012	03/17/2013
Amplifier	MITEQ	AM-1604-3000	1123808	03/18/2012	03/18/2013
Turn Table	EMCO	2081-1.21	N/A	N.C.R	N.C.R
Controller	CT	N/A	N/A	N.C.R	N.C.R
High Noise Amplifier	Agilent	8449B	3008A01838	03/18/2012	03/18/2013
Bilog Antenna	SCHAFFNER	CBL6143	5082	03/17/2012	03/17/2013
Horn Antenna	SCHWARZBECK	BBHA9120	D286	03/17/2012	03/17/2013
Loop Antenna	A、R、A	PLA-1030/B	1029	03/23/2012	03/23/2013
Temp. / Humidity Meter	VICTOR	VC230	N/A	03/19/2012	03/19/2013
Antenna Tower	SUNOL	TLT2	N/A	N.C.R	N.C.R
Test S/W	FARAD	LZ-RF / CCS-SZ-3A2			

Test Configuration

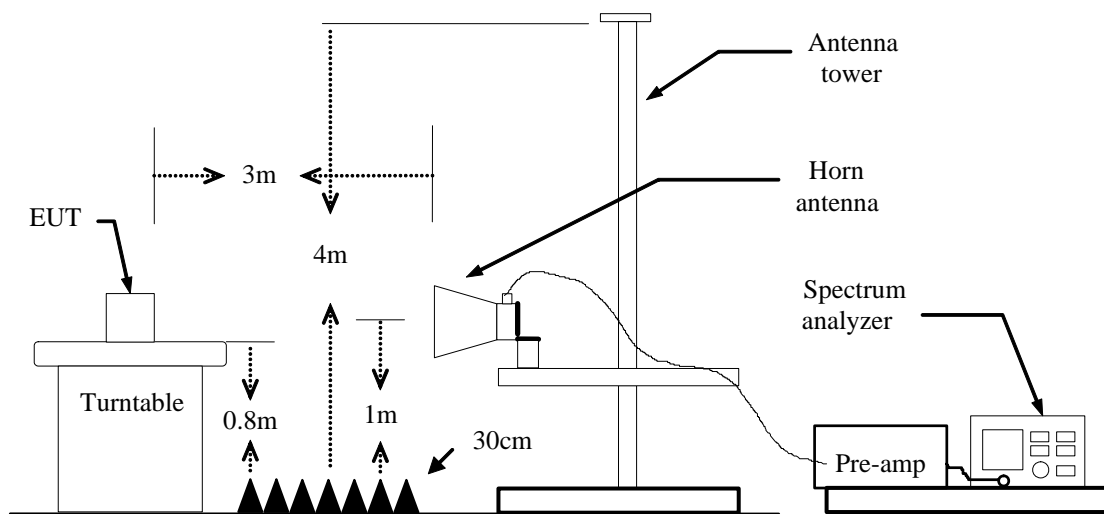



TEST PROCEDURE

1. The EUT is placed on a turntable, which is 0.8m above the ground plane.
2. The turntable shall be rotated for 360 degrees to determine the position of maximum emission level.
3. EUT is set 3m away from the receiving antenna, which is varied from 1m to 4m to find out the highest emission.
4. Set the spectrum analyzer in the following setting in order to capture the lower and upper band-edges of the emission:
 - (a) PEAK: RBW=VBW=1MHz / Sweep=AUTO
 - (b) AVERAGE: RBW=1MHz / VBW=510Hz / Sweep=AUTO
5. Repeat the procedures until all the PEAK and AVERAGE versus POLARIZATION are measured.

TEST RESULTS

Refer to attach spectrum analyzer data chart.



Test Data (GFSK)

Band Edges (CH-Low)

Detector mode: Peak

Polarity: Vertical

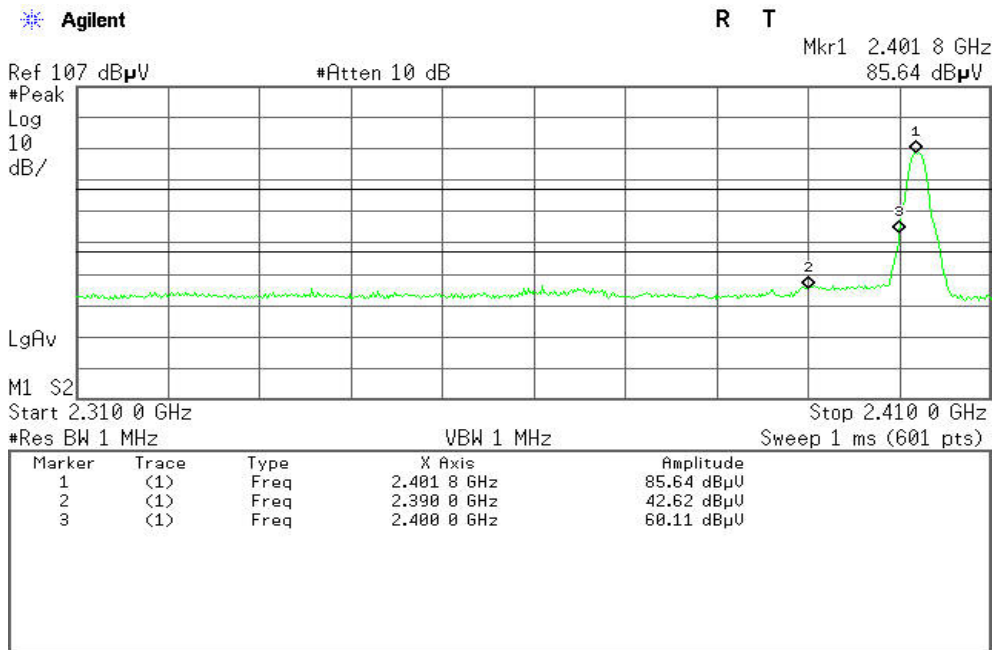

Detector mode: Average

Polarity: Vertical

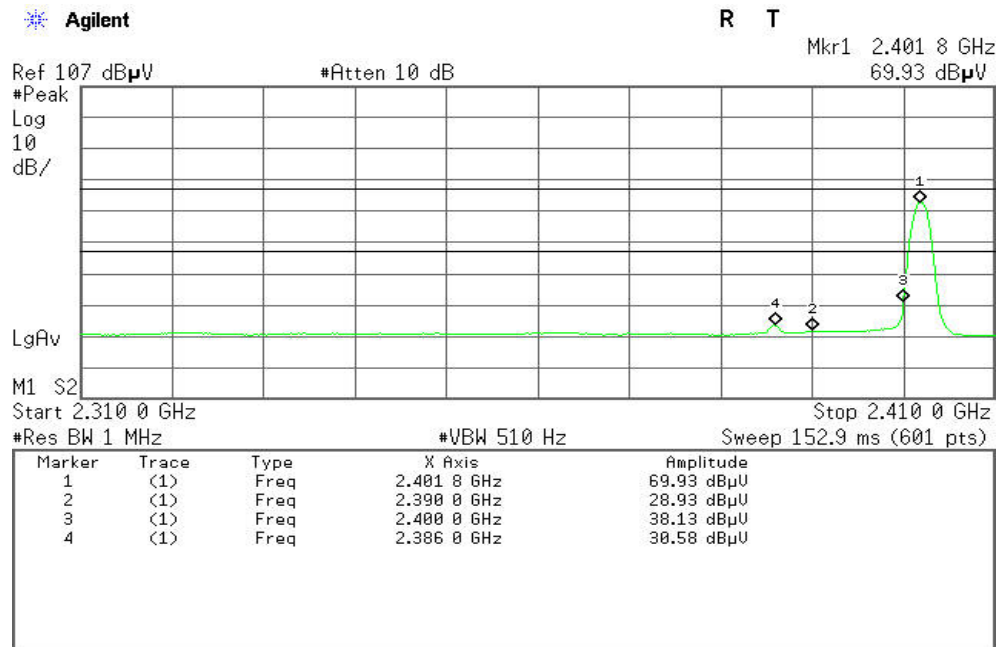



Detector mode: Peak

Polarity: Horizontal

Agilent

R T

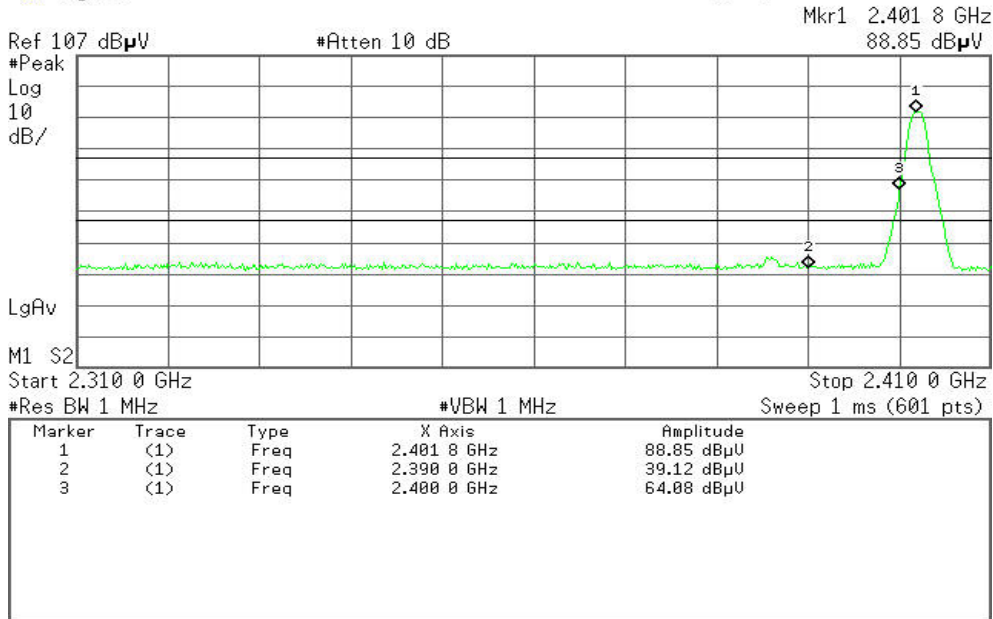

Detector mode: Average

Polarity: Horizontal

Agilent

R T

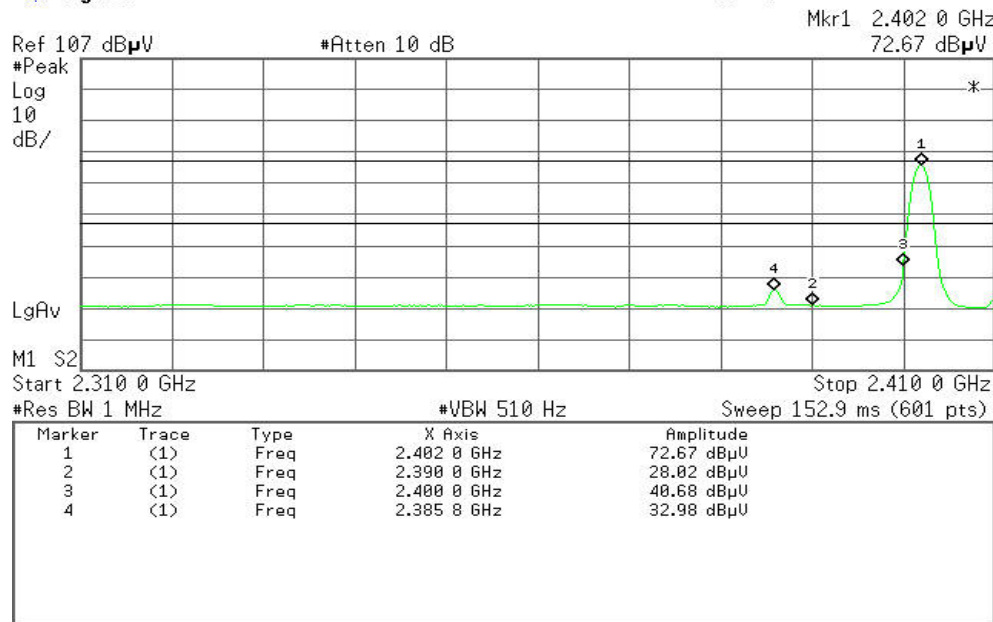



Band Edges (CH-High)

Detector mode: Peak

Polarity: Vertical

Agilent

R T

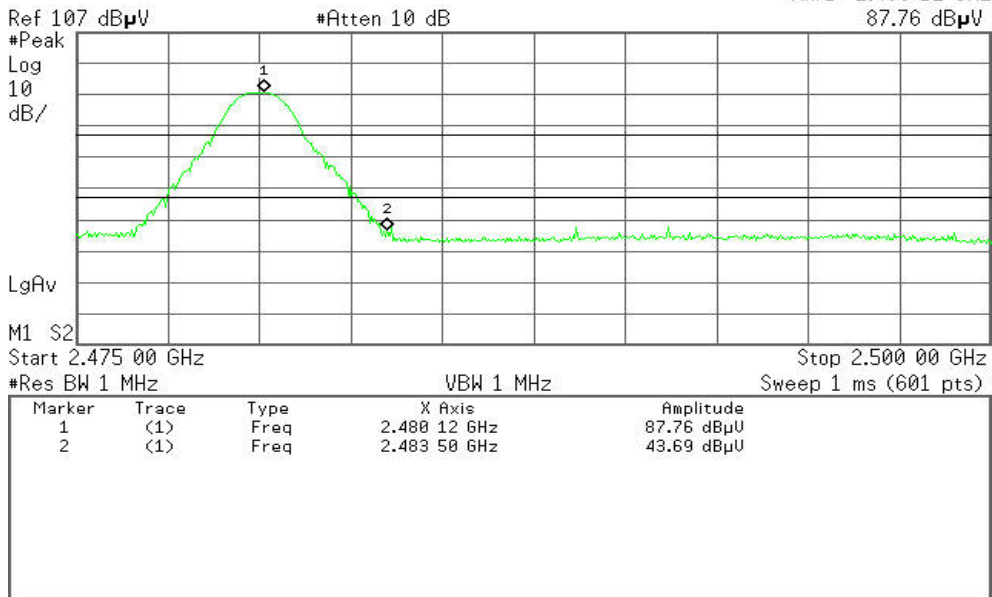

Detector mode: Average

Polarity: Vertical

Agilent

R T

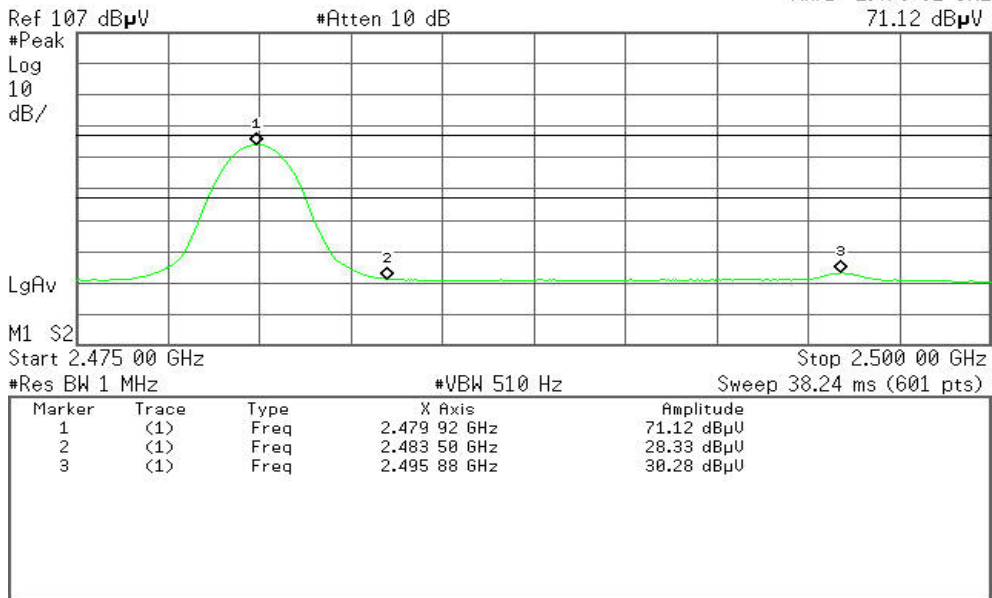



Detector mode: Peak

Polarity: Horizontal

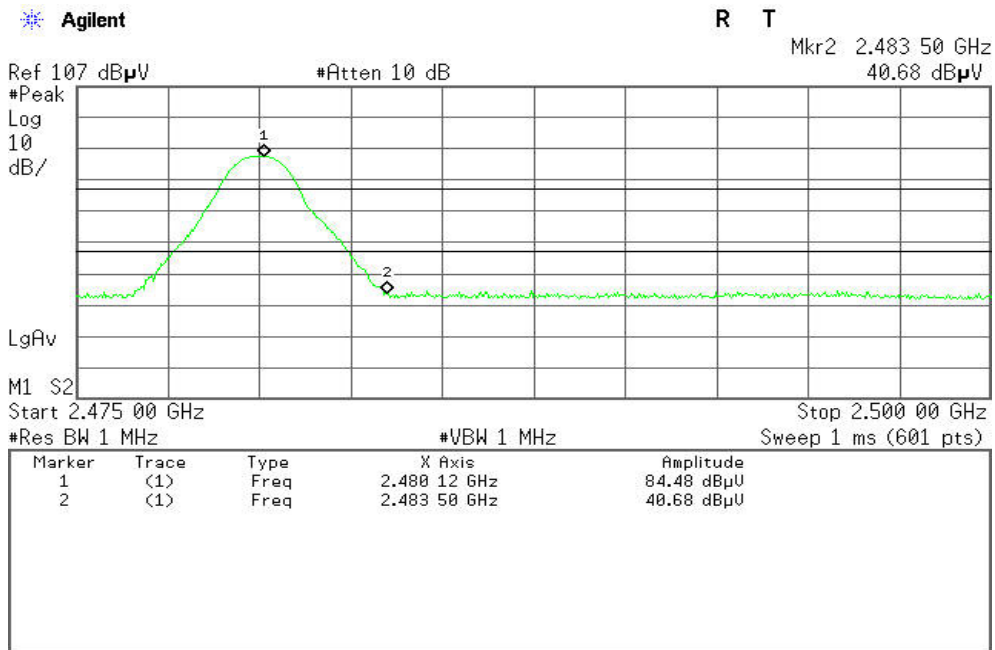

Detector mode: Average

Polarity: Horizontal

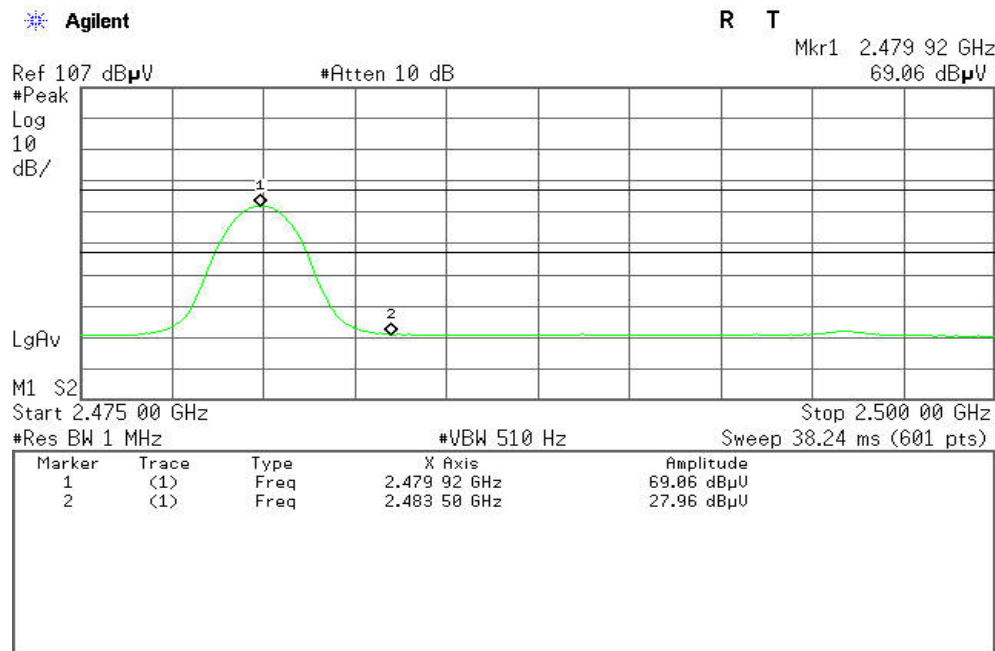



Test Data (8DPSK)

Band Edges (CH-Low)

Detector mode: Peak

Polarity: Vertical

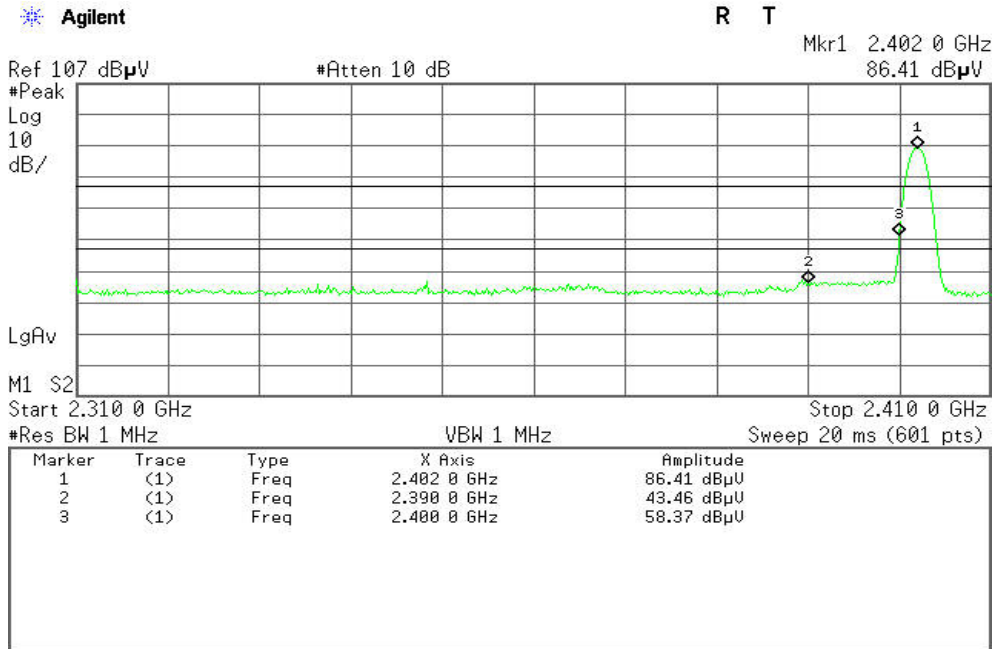

Detector mode: Average

Polarity: Vertical

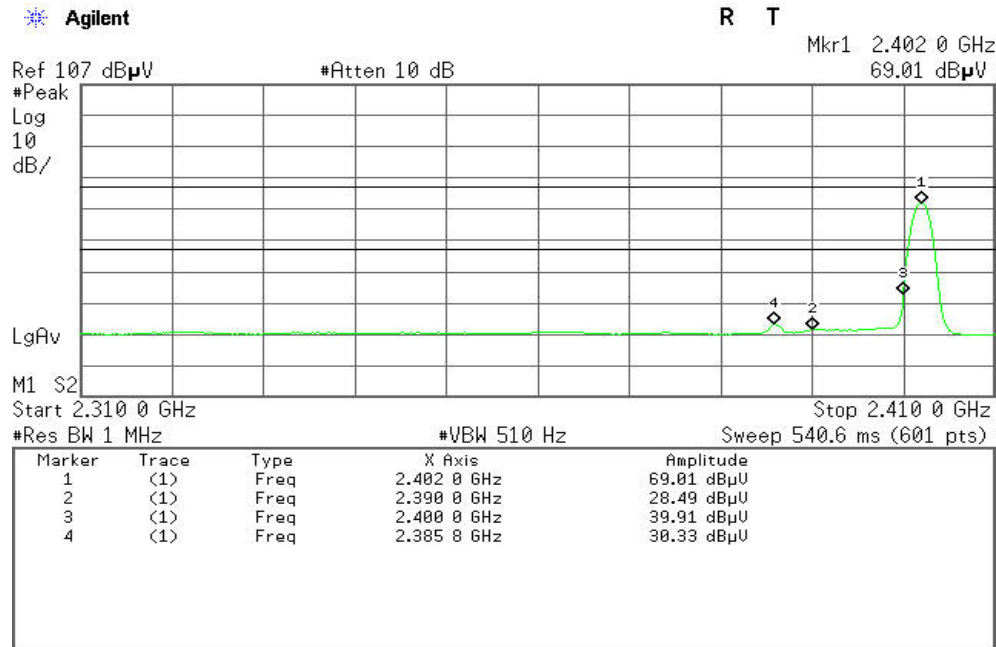



Detector mode: Peak

Polarity: Horizontal

Agilent

R T

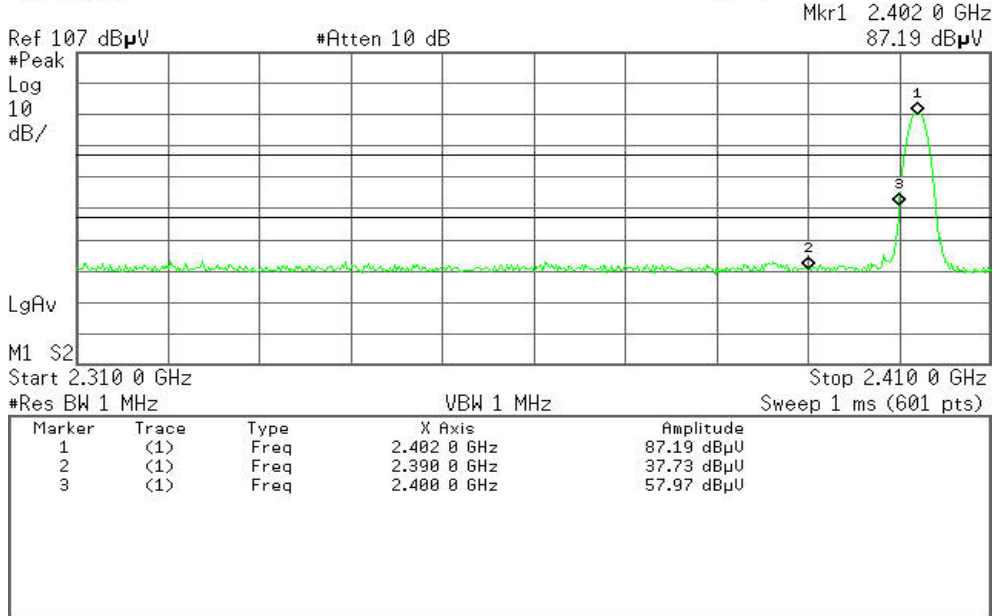

Detector mode: Average

Polarity: Horizontal

Agilent

R T

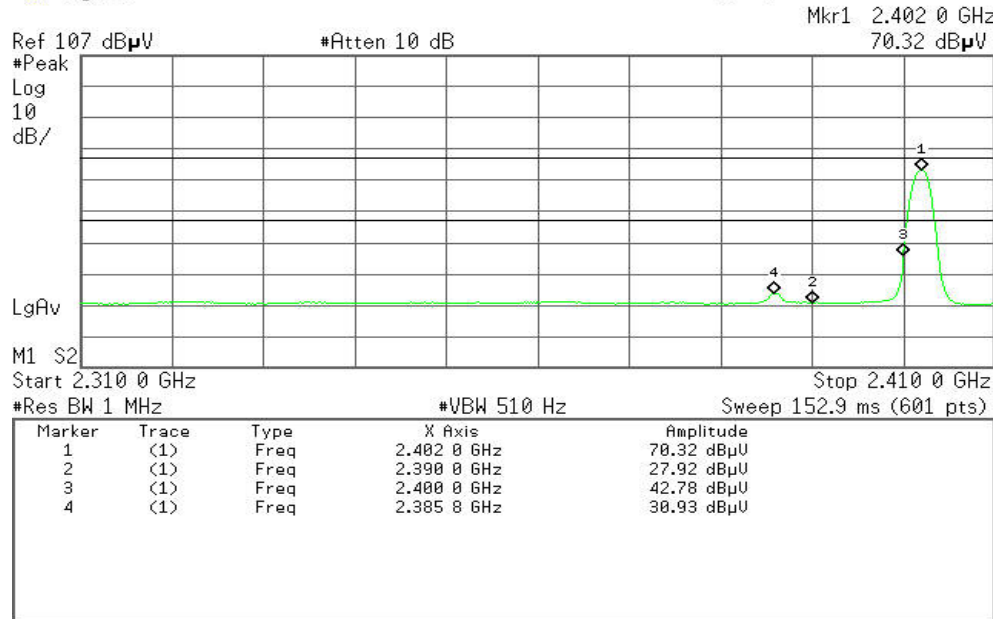



Band Edges (CH-High)

Detector mode: Peak

Polarity: Vertical

Agilent

R T

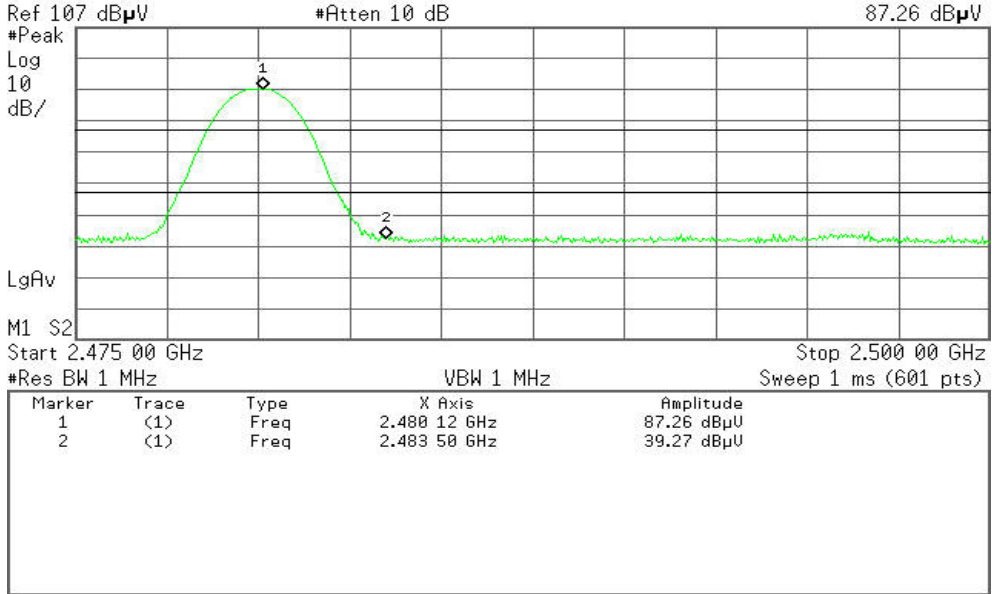

Detector mode: Average

Polarity: Vertical

Agilent

R T

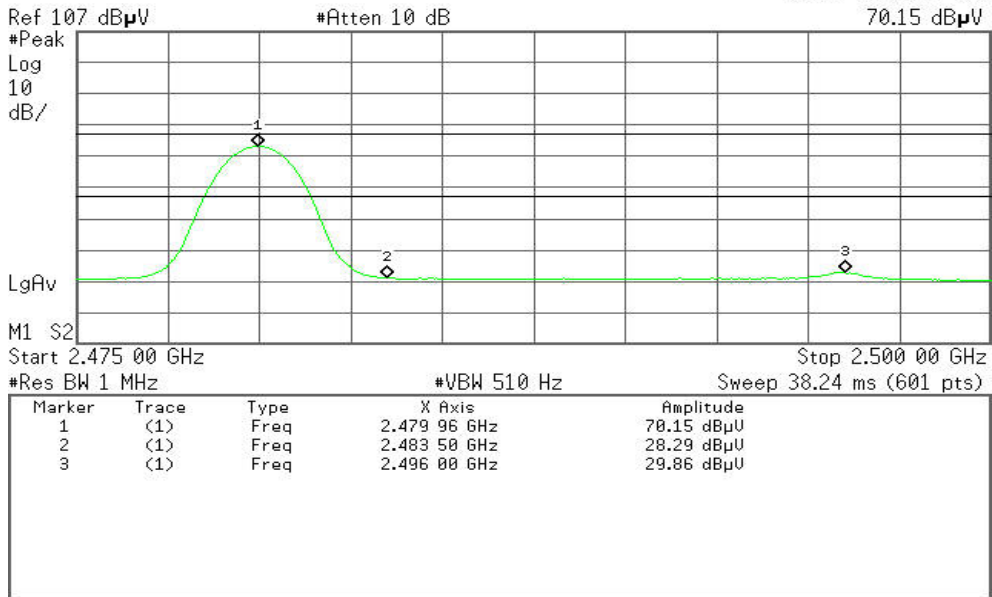



Detector mode: Peak

Polarity: Horizontal

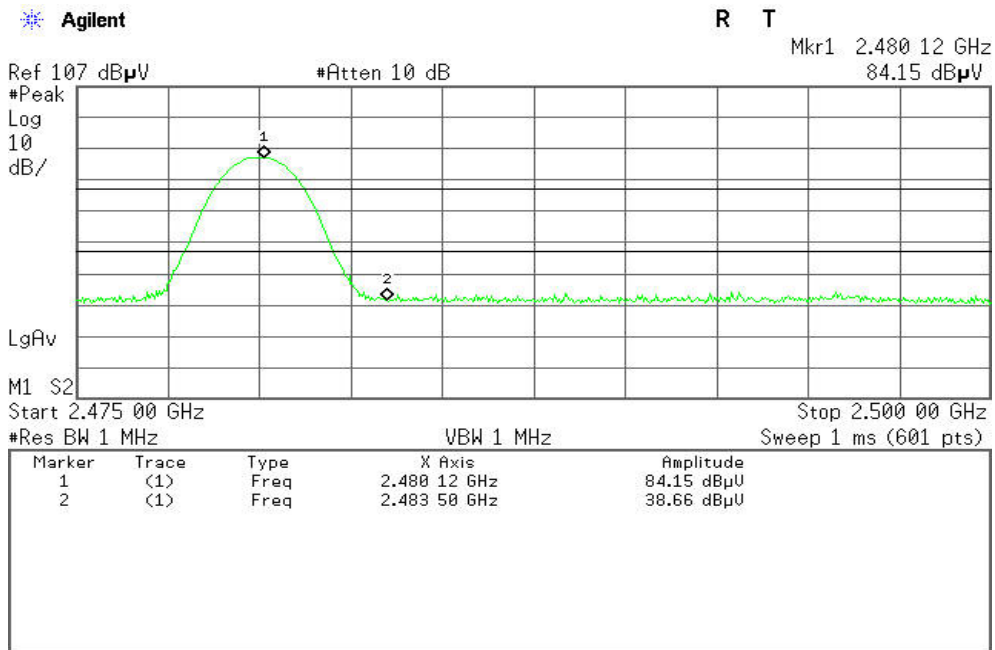

Detector mode: Average

Polarity: Horizontal

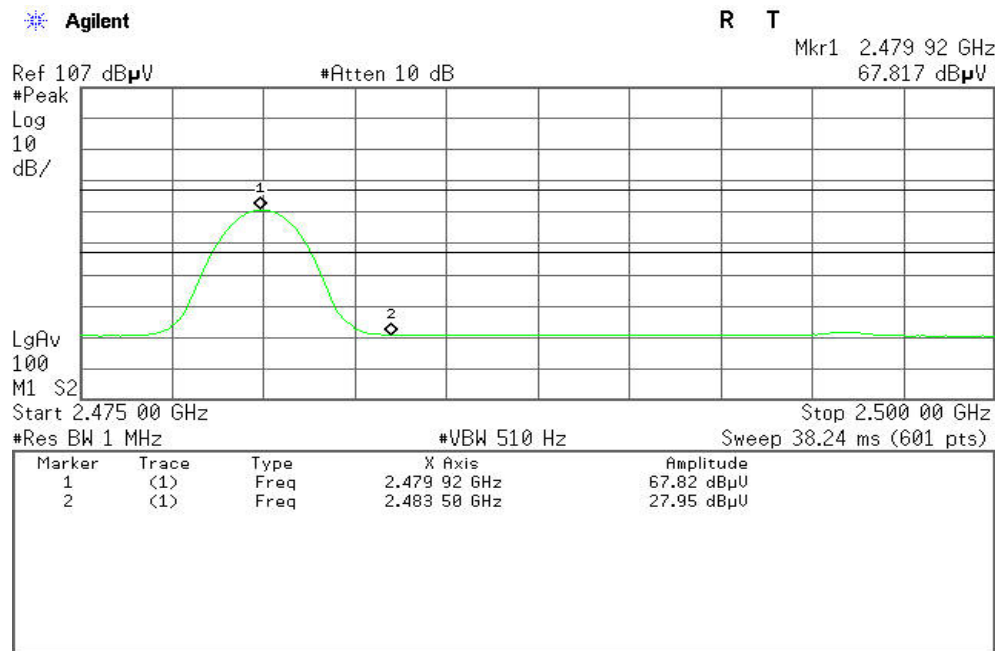



6.5 FREQUENCY SEPARATION

LIMIT

According to §15.247(a)(1), Frequency hopping systems shall have hopping channel carrier frequencies separated by a minimum of 25 kHz or the 20 dB bandwidth of the hopping channel, whichever is greater. Alternatively, frequency hopping systems operating in the 2400-2483.5 MHz band may have hopping channel carrier frequencies that are separated by 25 kHz or two-thirds of the 20 dB bandwidth of the hopping channel, whichever is greater, provided the systems operate with an output power no greater than 125 mW.

MEASUREMENT EQUIPMENT USED

Name of Equipment	Manufacturer	Model	Serial Number	Last Calibration	Due Calibration
Spectrum Analyzer	Agilent	E4446A	US44300399	03/19/2012	03/19/2013

Remark: Each piece of equipment is scheduled for calibration once a year.

Test Configuration

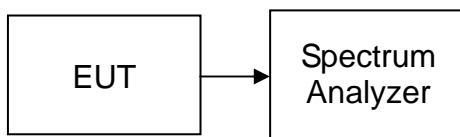

TEST PROCEDURE

1. Place the EUT on the table and set it in transmitting mode.
2. Remove the antenna from the EUT and then connect a low loss RF cable from the antenna port to the spectrum analyzer.
3. Set center frequency of spectrum analyzer = middle of hopping channel.
4. Set the spectrum analyzer as RBW=30kHz, VBW=30kHz, Adjust Span to 4 MHz, Sweep = auto.
5. Max hold. Mark 3 Peaks of hopping channel and record the 3 peaks frequency.

TEST RESULTS

No non-compliance noted

Test Data

GFSK

Channel Separation (MHz)	Two-thirds of the 20 dB Bandwidth (kHz)	Channel Separation Limit	Result
1.000	562.327	> Two-thirds of the 20 dB Bandwidth	Pass

8DPSK

Channel Separation (MHz)	Two-thirds of the 20 dB Bandwidth (kHz)	Channel Separation Limit	Result
1.000	808.667	> Two-thirds of the 20 dB Bandwidth	Pass



GFSK

Test Plot

Measurement of Channel Separation

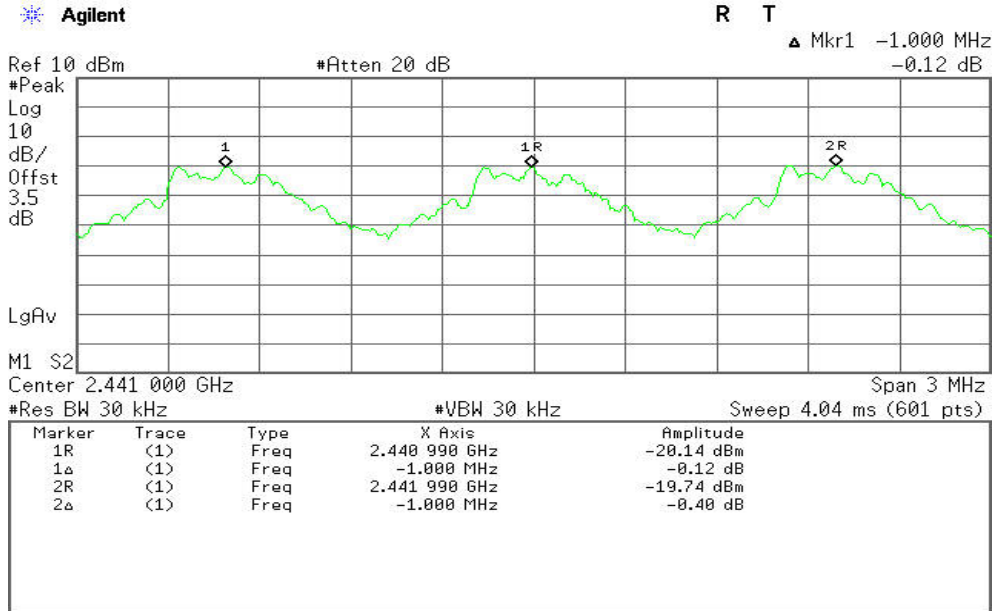

20 dB bandwidth(CH High)

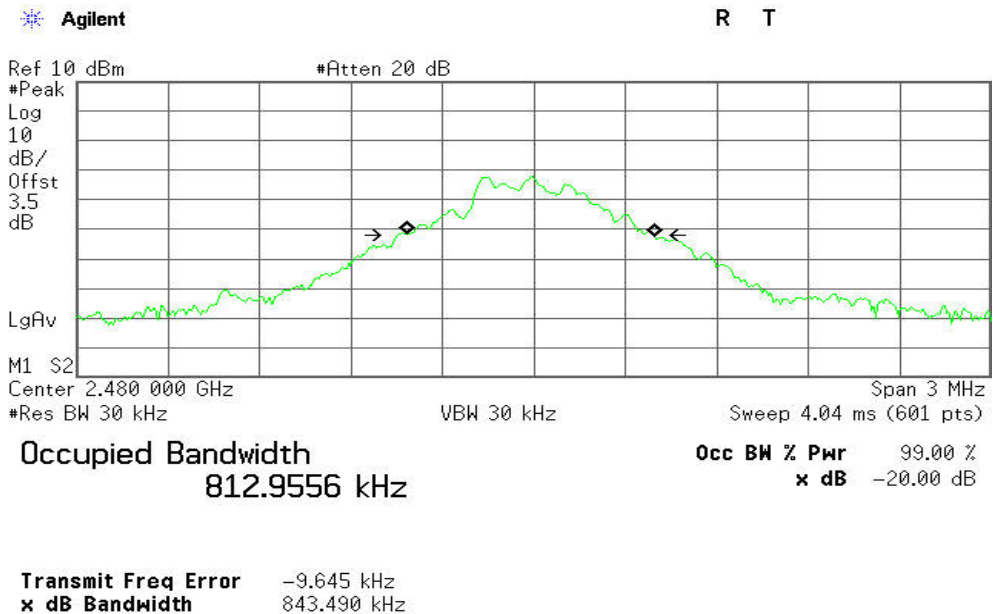



8DPSK

Test Plot

Measurement of Channel Separation

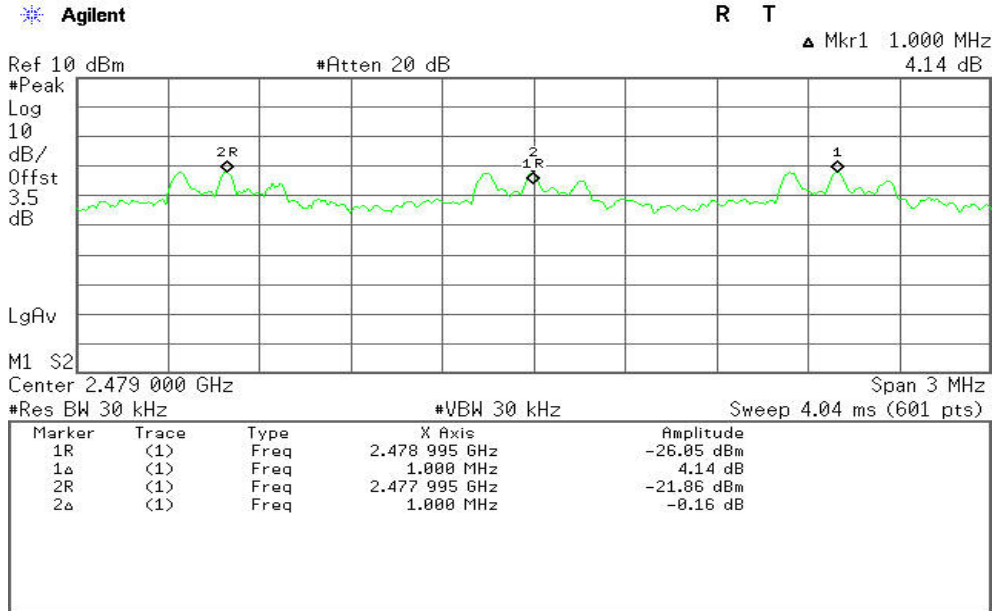

20 dB bandwidth(CH Low)

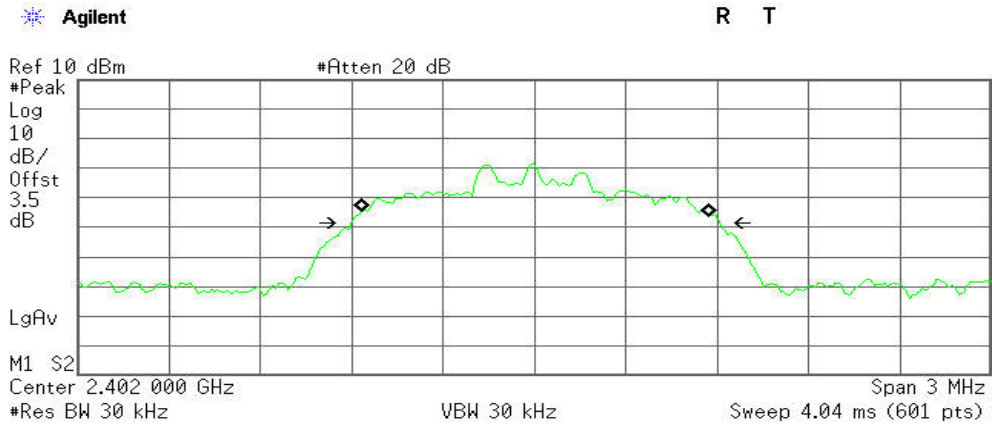

Occupied Bandwidth
1.1346 MHz

Occ BW % Pwr 99.00 %
x dB -20.00 dB

Transmit Freq Error 2.654 kHz
x dB Bandwidth 1.213 MHz



6.6 NUMBER OF HOPPING FREQUENCY

LIMIT

According to §15.247(a)(1)(ii), Frequency hopping systems operating in the 2400MHz-2483.5 MHz bands shall use at least 15 hopping frequencies.

MEASUREMENT EQUIPMENT USED

Name of Equipment	Manufacturer	Model	Serial Number	Last Calibration	Due Calibration
Spectrum Analyzer	Agilent	E4446A	US44300399	03/19/2012	03/19/2013

Remark: Each piece of equipment is scheduled for calibration once a year.

Test Configuration

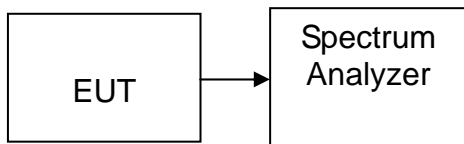

TEST PROCEDURE

1. Place the EUT on the table and set it in transmitting mode.
2. Remove the antenna from the EUT and then connect a low loss RF cable from the antenna port to the spectrum analyzer.
3. Set spectrum analyzer Start=2400MHz, Stop = 2441.5MHz, Sweep = 1ms and Start=2441.5MHz, Stop = 2483.5MHz, Sweep = 1ms.
4. Set the spectrum analyzer as RBW, VBW=300kHz,
5. Max hold, view and count how many channel in the band.

TEST RESULTS

No non-compliance noted

Test Data

Result (No. of CH)	Limit (No. of CH)	Result
79	>15	PASS



Test Plot (GFSK)

Channel Number

2.400 GHz – 2.4415 GHz

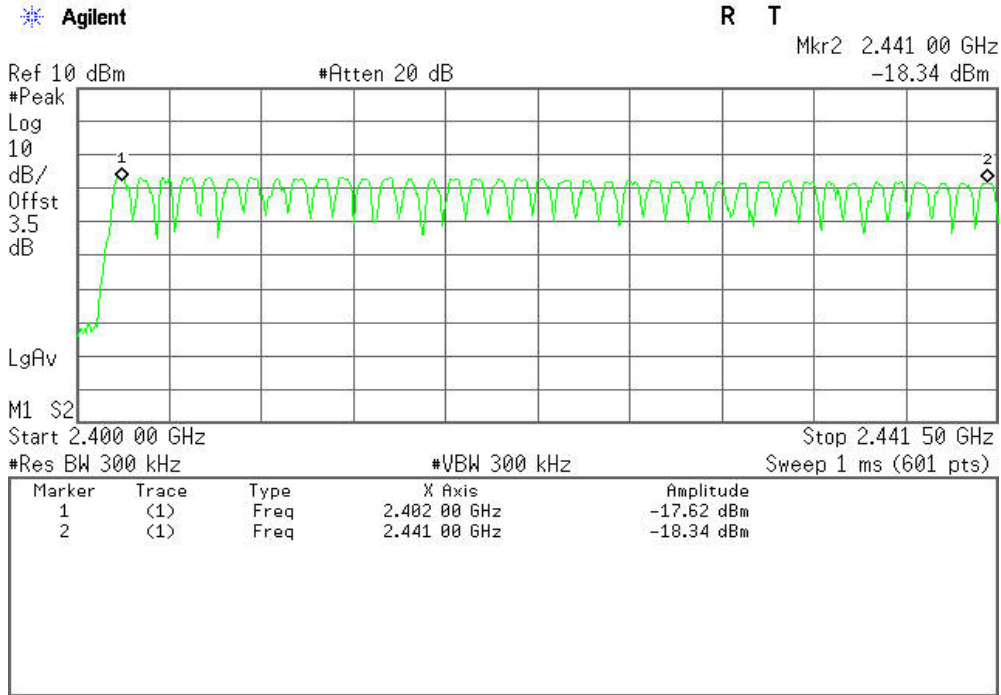

2.4415 GHz –2.4830 GHz

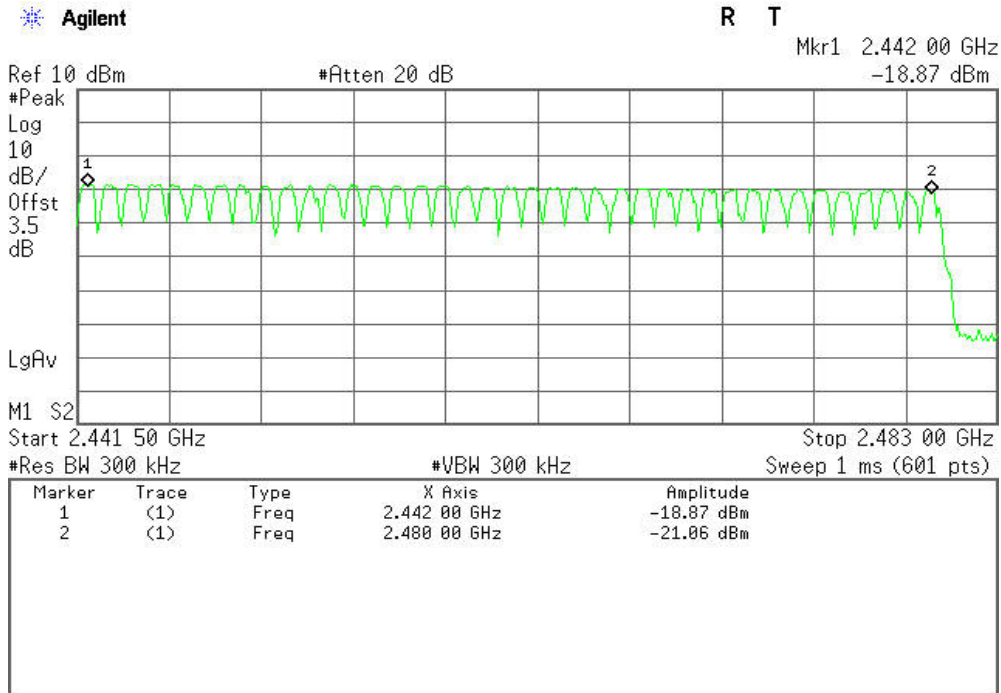



Test Plot (8DPSK)

Channel Number

2.400 GHz – 2.4415 GHz

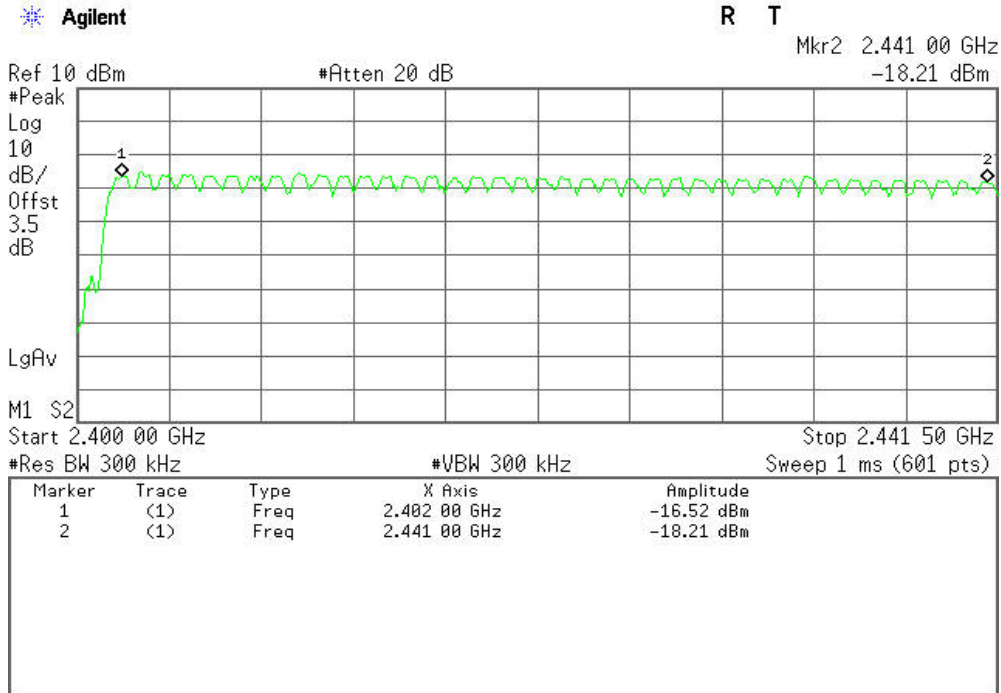

2.4415 GHz –2.4835 GHz

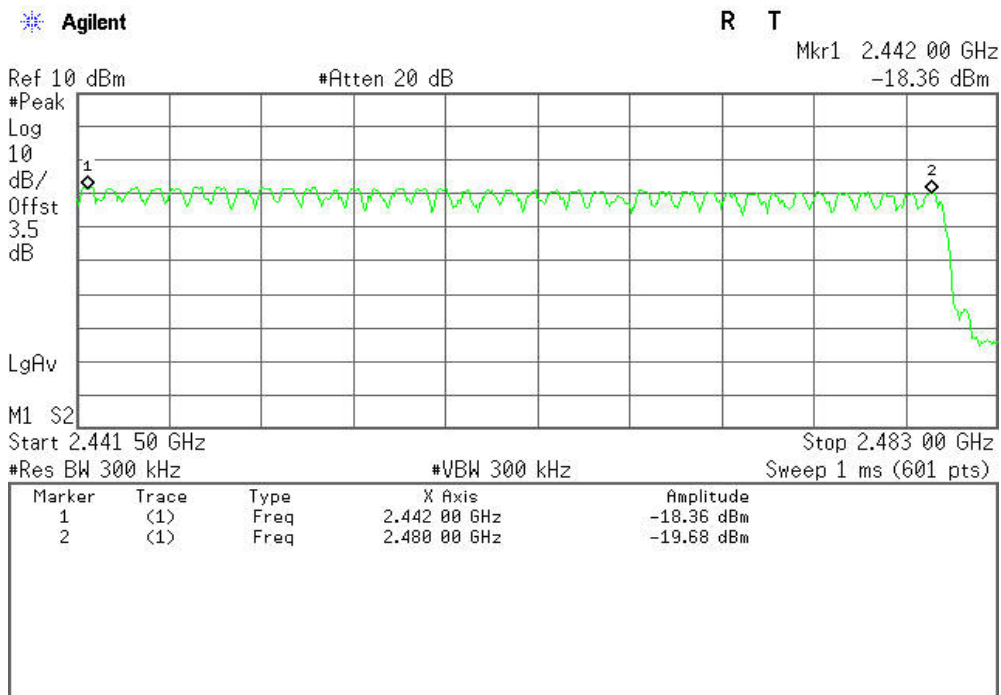



6.7 TIME OF OCCUPANCY (DWELL TIME)

LIMIT

According to §15.247(a)(1)(iii), Frequency hopping systems operating in the 2400MHz-2483.5 MHz bands. The average time of occupancy on any channels shall not greater than 0.4 s within a period 0.4 s multiplied by the number of hopping channels employed.

MEASUREMENT EQUIPMENT USED

Name of Equipment	Manufacturer	Model	Serial Number	Last Calibration	Due Calibration
Spectrum Analyzer	Agilent	E4446A	US44300399	03/19/2012	03/19/2013

Remark: Each piece of equipment is scheduled for calibration once a year.

Test Configuration

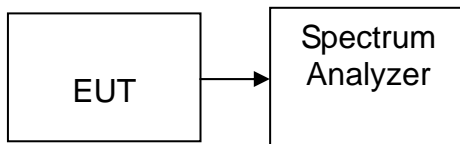

TEST PROCEDURE

1. Place the EUT on the table and set it in transmitting mode.
2. Remove the antenna from the EUT and then connect a low loss RF cable from the antenna port to the spectrum analyzer.
3. Set center frequency of spectrum analyzer = operating frequency.
4. Set the spectrum analyzer as RBW, VBW=1MHz, Span = 0Hz, Sweep = auto.
5. Repeat above procedures until all frequency measured were complete.



TEST RESULTS

No non-compliance noted

Test Data

GFSK

DH 1

CH Mid: $0.398 * (1600/2)/79 * 31.6 = 127.360$ (ms)

CH	Pulse Time (ms)	Total of Dwell (ms)	Period Time (s)	Limit (ms)	Result
Mid	0.398	127.360	31.60	400.00	PASS

DH 3

CH Mid: $1.650 * (1600/4)/79 * 31.6 = 264.000$ (ms)

CH	Pulse Time (ms)	Total of Dwell (ms)	Period Time (s)	Limit (ms)	Result
Mid	1.650	264.000	31.60	400.00	PASS

DH 5

CH Mid: $2.900 * (1600/6)/79 * 31.6 = 309.333$ (ms)

CH	Pulse Time (ms)	Total of Dwell (ms)	Period Time (s)	Limit (ms)	Result
Mid	2.900	309.333	31.60	400.00	PASS



Test Data

8DPSK

DH 1

CH Mid: $0.408 * (1600/2)/79 * 31.6 = 130.560$ (ms)

CH	Pulse Time (ms)	Total of Dwell (ms)	Period Time (s)	Limit (ms)	Result
Mid	0.408	130.560	31.60	400.00	PASS

DH 3

CH Mid: $1.660 * (1600/4)/79 * 31.6 = 265.600$ (ms)

CH	Pulse Time (ms)	Total of Dwell (ms)	Period Time (s)	Limit (ms)	Result
Mid	1.660	265.600	31.60	400.00	PASS

DH 5

CH Mid: $2.908 * (1600/6)/79 * 31.6 = 310.187$ (ms)

CH	Pulse Time (ms)	Total of Dwell (ms)	Period Time (s)	Limit (ms)	Result
Mid	2.908	310.187	31.60	400.00	PASS



Test Plot

GFSK

DH 1

(CH Mid)

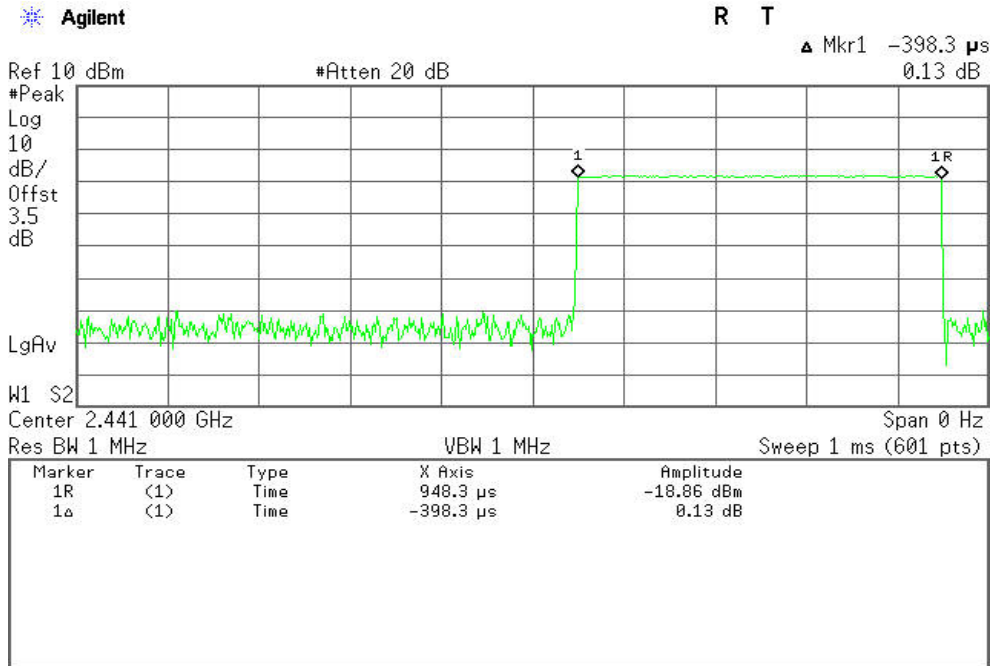

DH 3

(CH Mid)

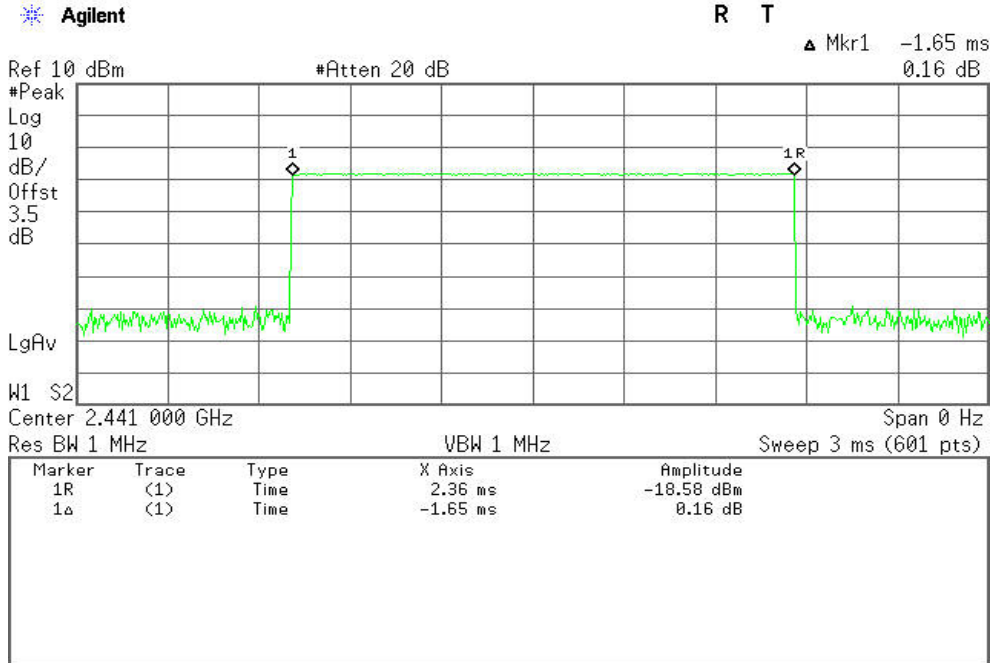



DH 5

(CH Mid)

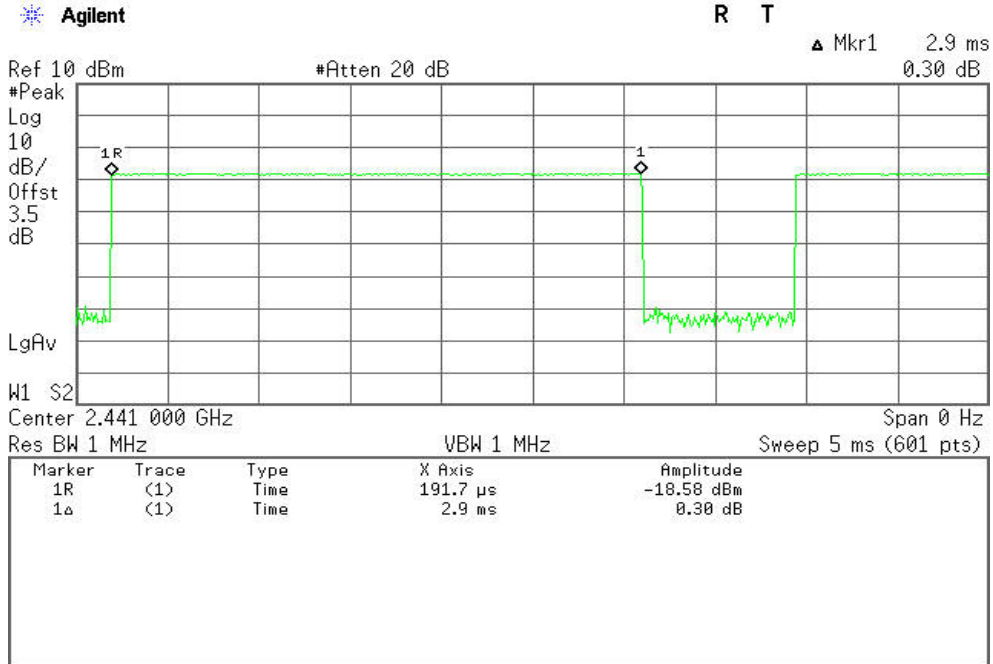



Test Plot
8DPSK

DH 1

(CH Mid)

Agilent

R T

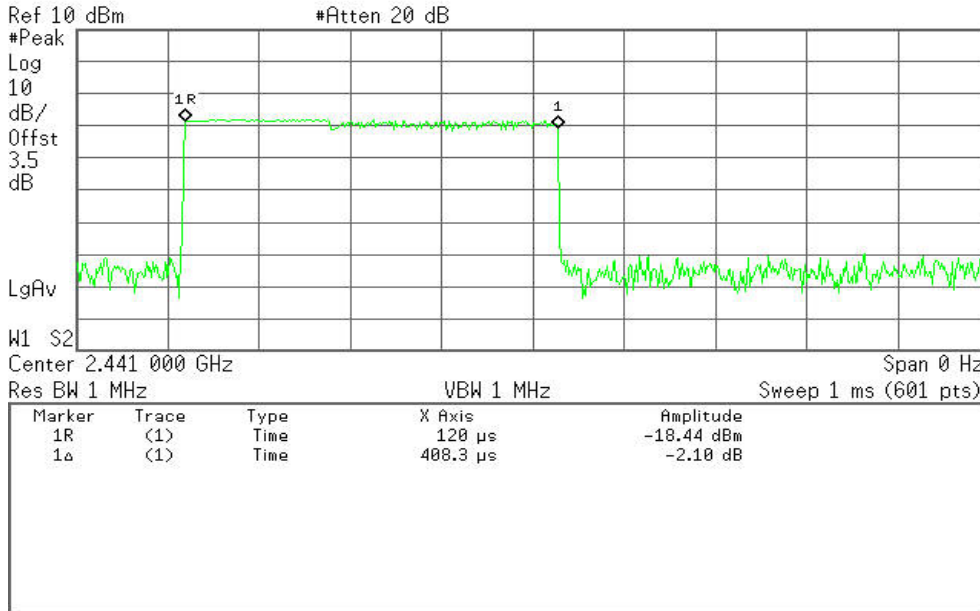

DH 3

(CH Mid)

Agilent

R T

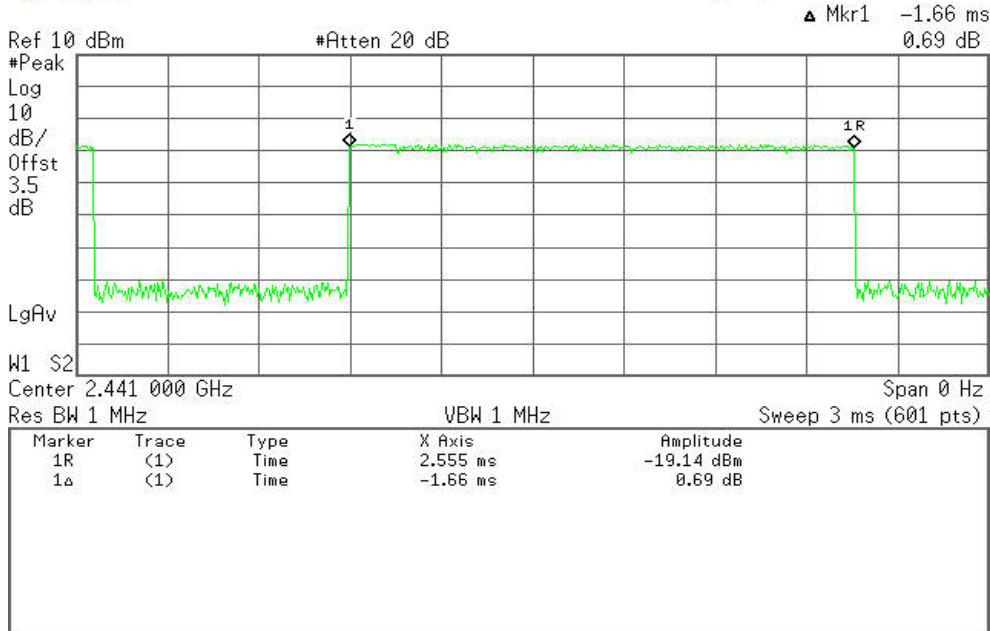



DH 5

(CH Mid)

Agilent

R T

▲ Mkr1 -2.908 ms
0.62 dB

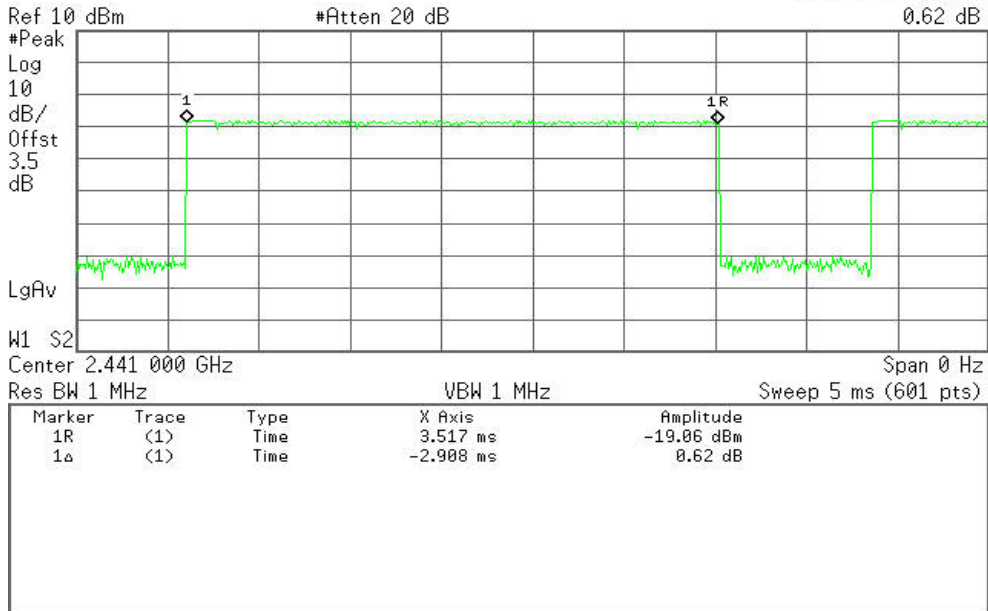



6.8 SPURIOUS EMISSIONS

6.8.1. Conducted Measurement

LIMIT

In any 100 kHz bandwidth outside the frequency band in which the spread spectrum or digitally modulated intentional radiator is operating, the radio frequency power that is produced by the intentional radiator shall be at least 20 dB below that in the 100 kHz bandwidth within the band that contains the highest level of the desired power, based on either an RF conducted or a radiated measurement. Attenuation below the general limits specified in Section 15.209(a) is not required. In addition, radiated emissions which fall in the restricted bands, as defined in Section 15.205(a), must also comply with the radiated emission limits specified in Section 15.209(a) (see Section 15.205(c)).

MEASUREMENT EQUIPMENT USED

Name of Equipment	Manufacturer	Model	Serial Number	Last Calibration	Due Calibration
Spectrum Analyzer	Agilent	E4446A	US44300399	03/19/2012	03/19/2013

Remark: Each piece of equipment is scheduled for calibration once a year.

Test Configuration

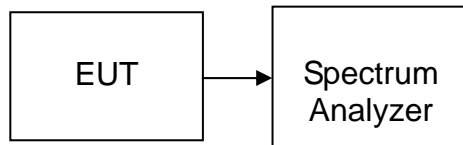

TEST PROCEDURE

Conducted RF measurements of the transmitter output were made to confirm that the EUT antenna port conducted emissions meet the specified limit and to identify any spurious signals that require further investigation or measurements on the radiated emissions site.

The transmitter output is connected to the spectrum analyzer. The resolution bandwidth is set to 100 kHz. The video bandwidth is set to 100 kHz.

Measurements are made over the 30MHz to 26GHz range with the transmitter set to the lowest, middle, and highest channels.

TEST RESULTS

No non-compliance noted



Test Plot (GFSK)

CH Low

30MHz ~2.9GHz

Agilent

R T

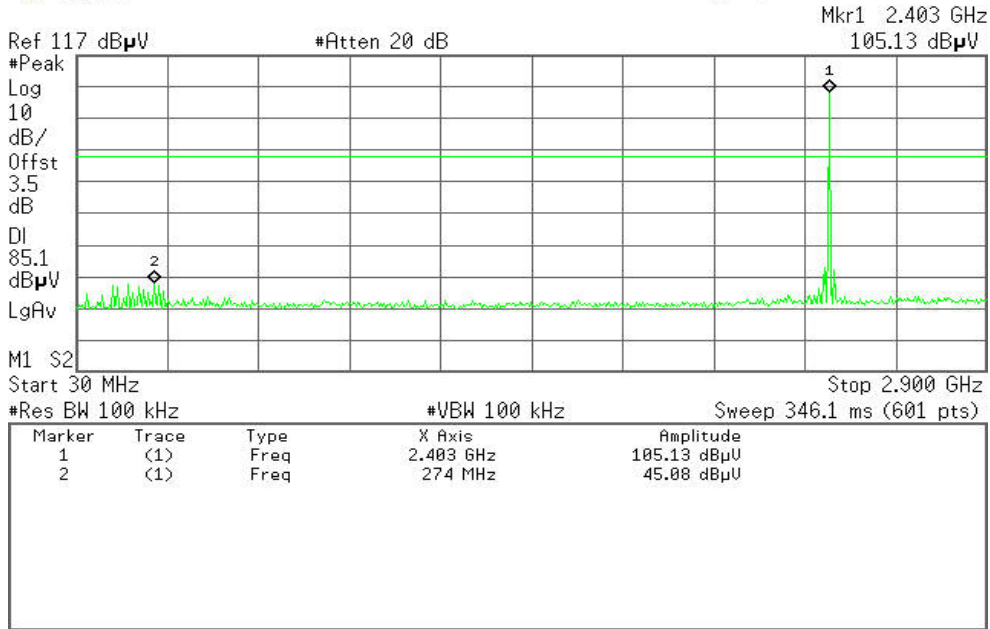

2.9GHz ~26.5GHz

Agilent

R T

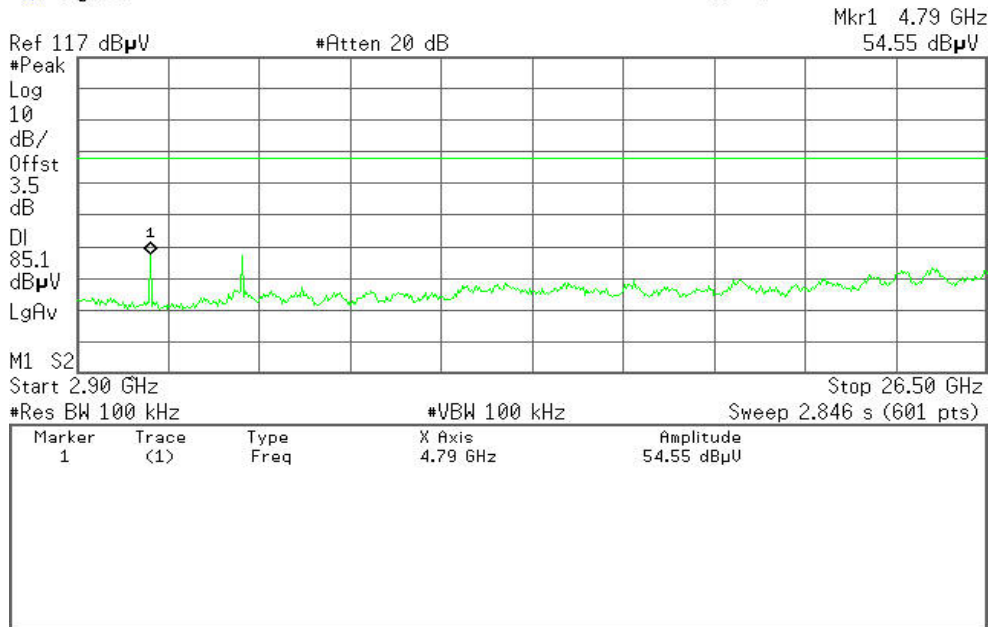



CH Mid

30MHz ~ 2.9GHz

Agilent

R T

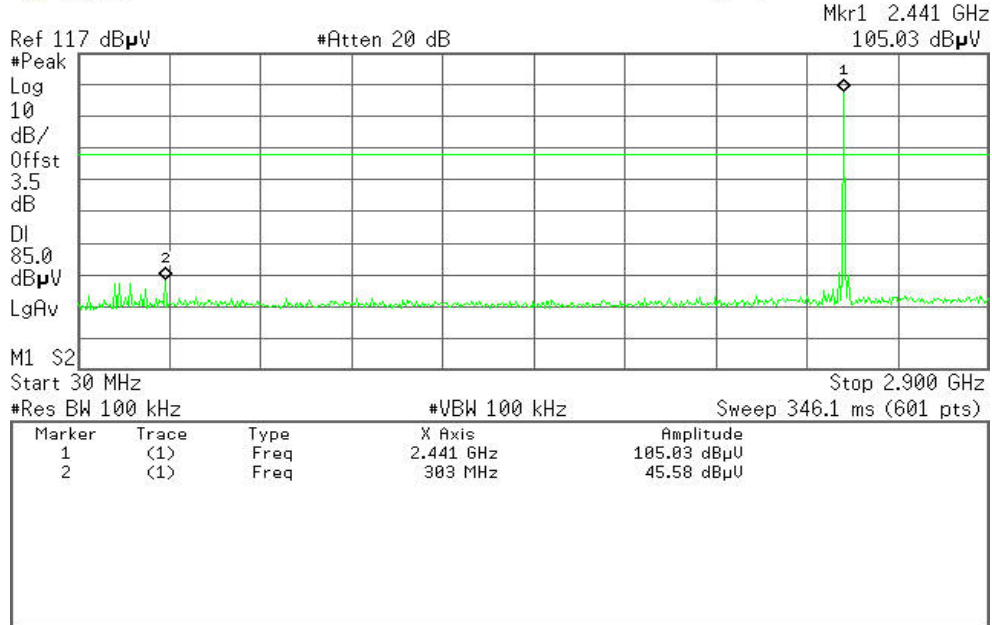

2.9GHz ~ 26.5GHz

Agilent

R T

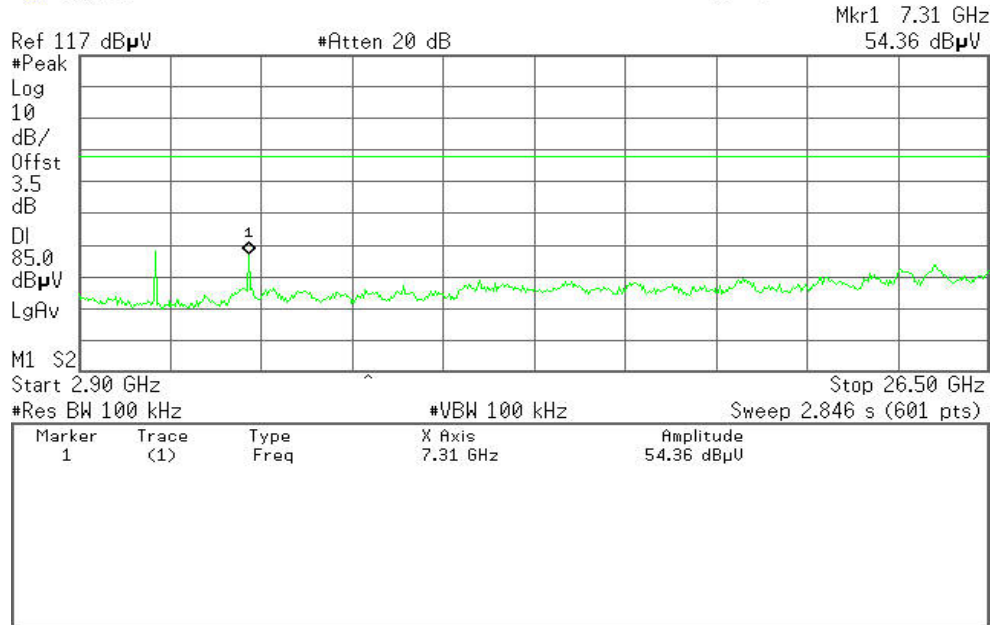



CH High

30MHz ~ 2.9GHz

Agilent

R T

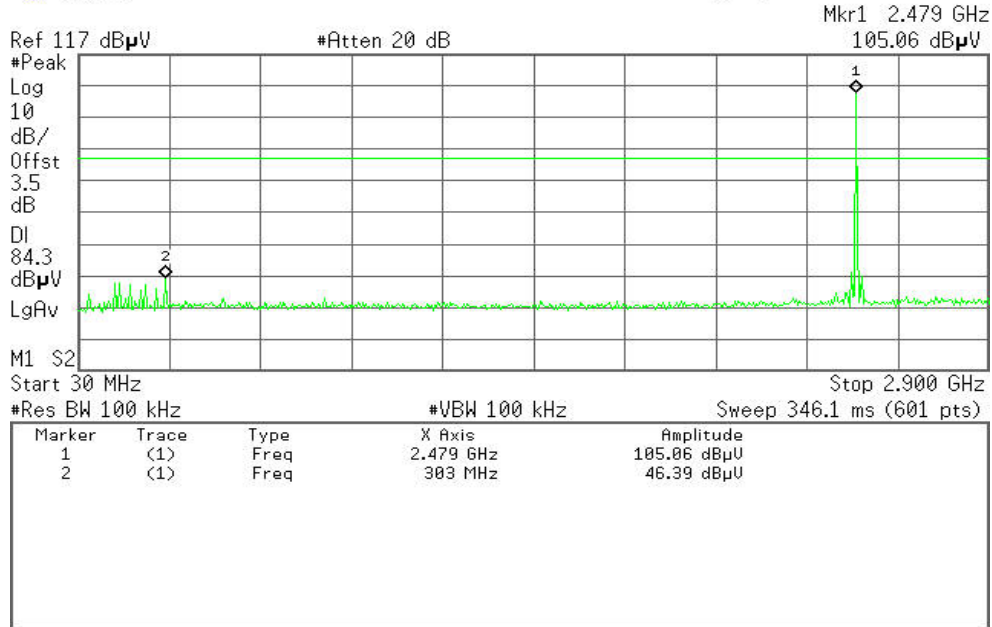

2.9GHz ~ 26.5GHz

Agilent

R T

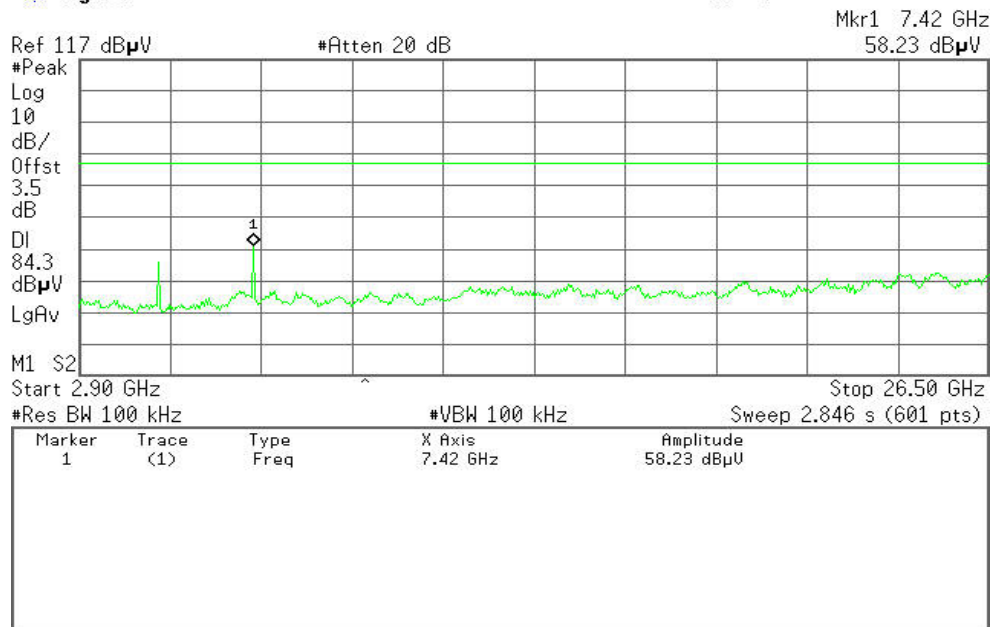



Test Plot (8DPSK)

CH Low

30MHz ~2.9GHz

Agilent

R T

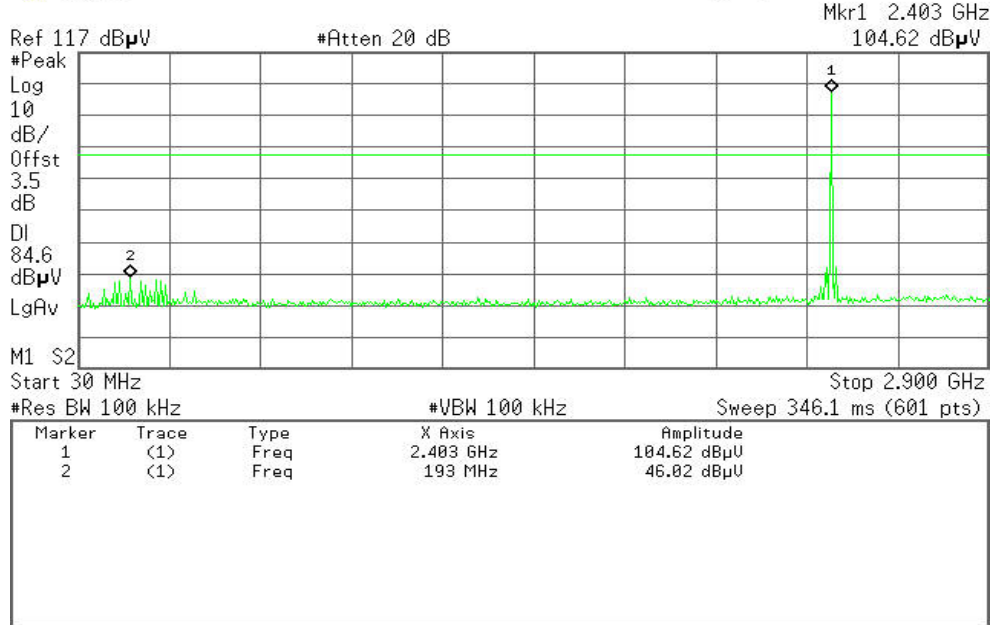

2.9GHz ~26.5GHz

Agilent

R T

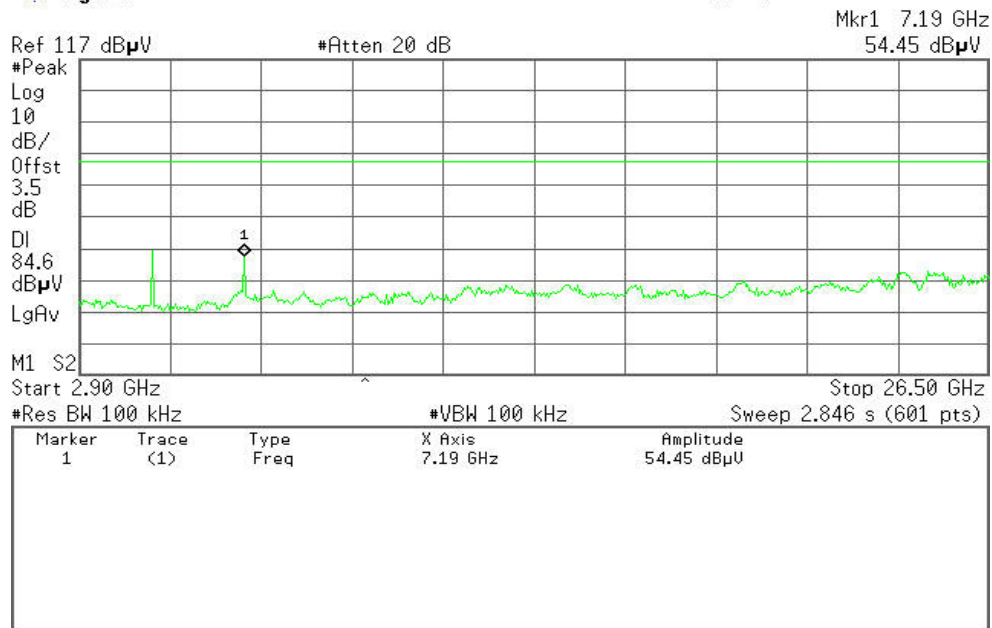



CH Mid

30MHz ~ 2.9GHz

Agilent

R T

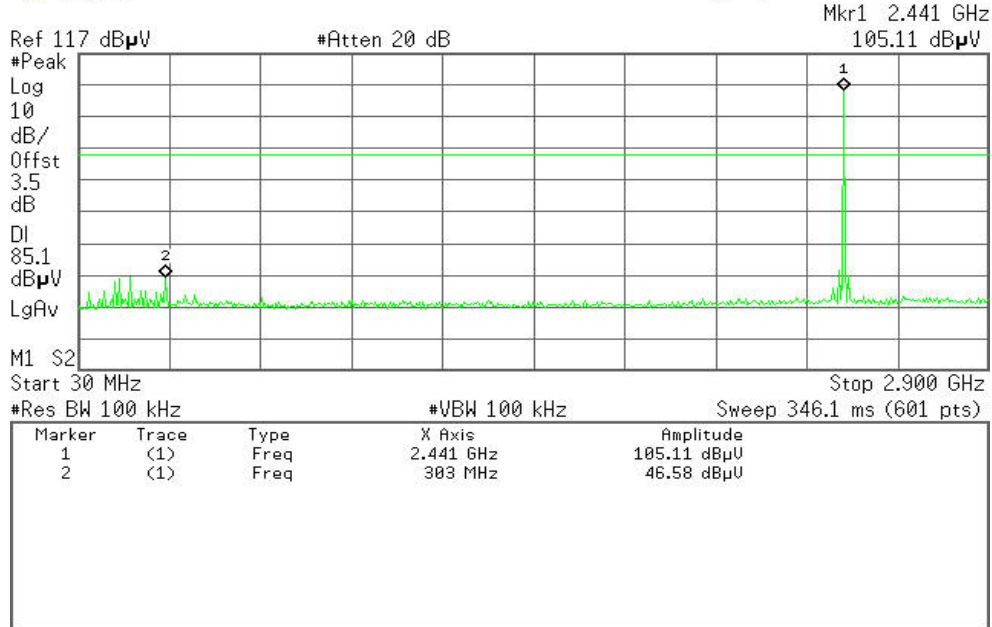

2.9GHz ~ 26.5GHz

Agilent

R T

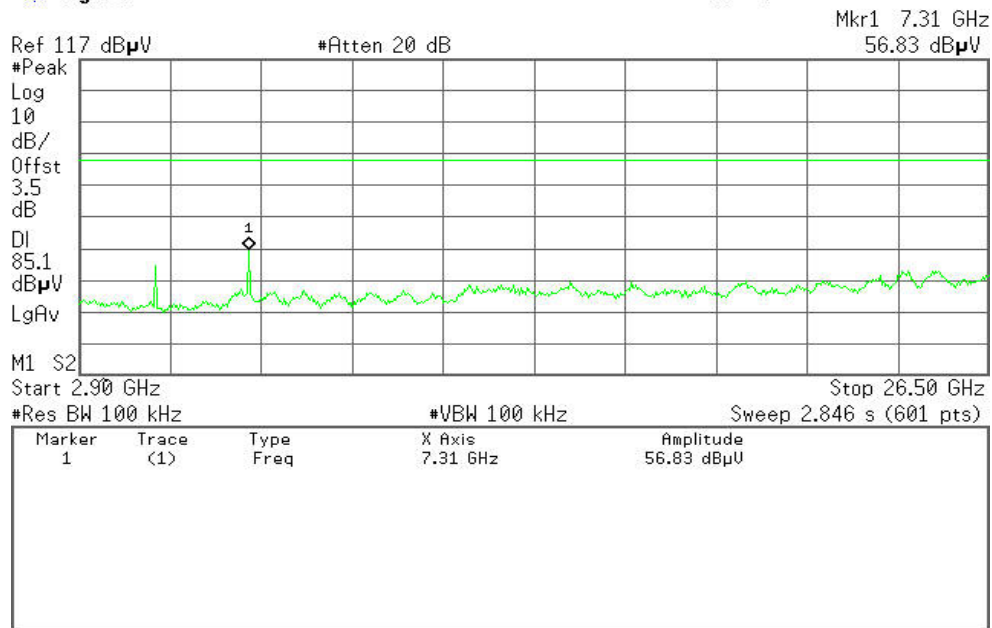



CH High

30MHz ~ 2.9GHz

Agilent

R T

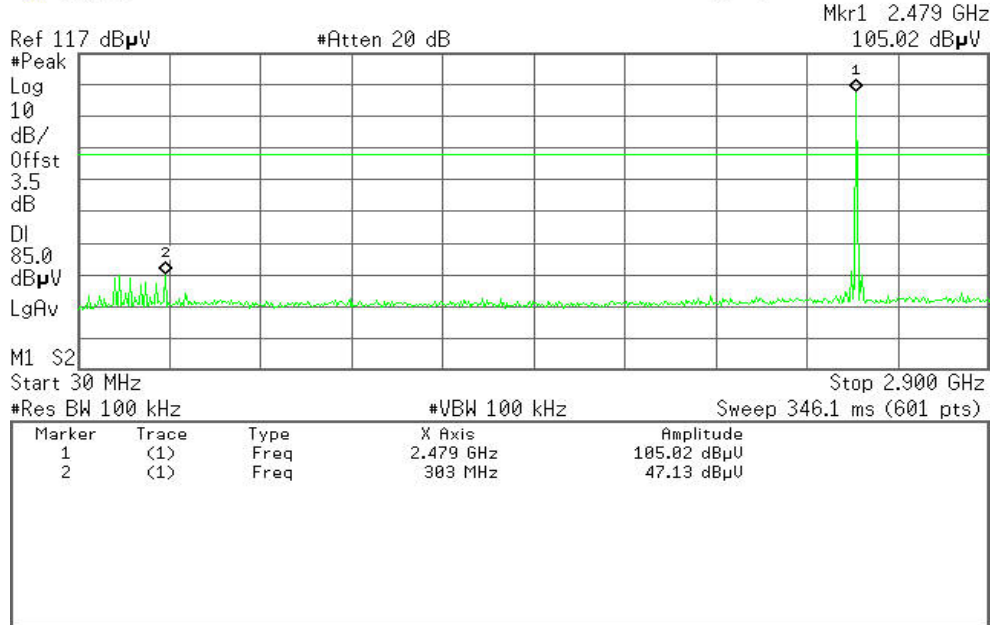

2.9GHz ~ 26.5GHz

Agilent

R T

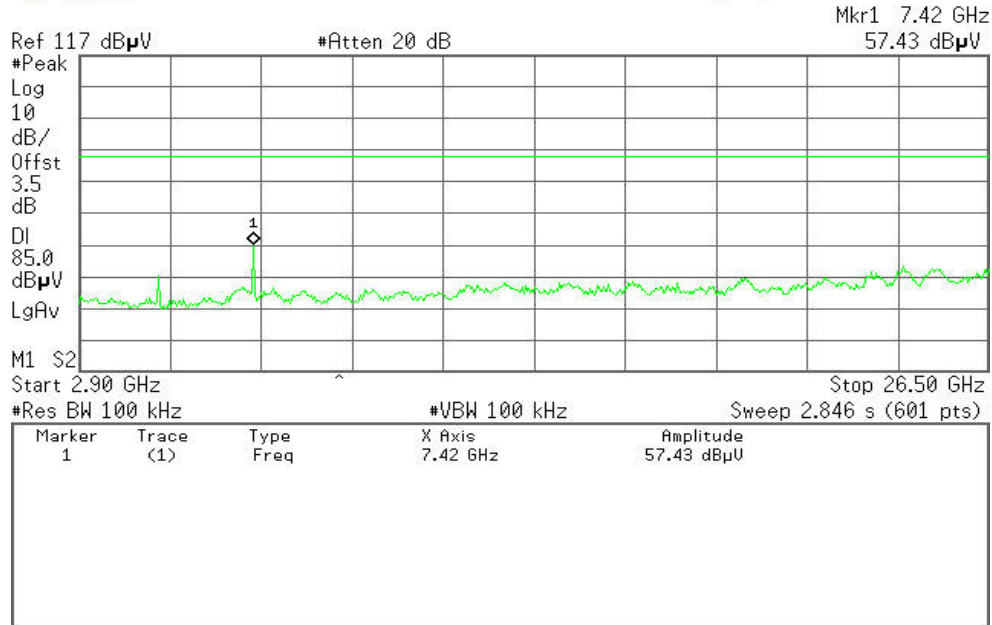



6.8.2. Radiated Emissions

LIMIT

1. Except as provided elsewhere in this Subpart, the emissions from an intentional radiator shall not exceed the field strength levels specified in the following table:

Frequency (MHz)	Field Strength (mV/m)	Measurement Distance (m)
0.009-0.490	2400/F(kHz)	300
0.490-1.705	24000/F(kHz)	30
1.705-30.0	30	30
30-88	100*	3
88-216	150*	3
216-960	200*	3
Above 960	500	3

Note: Except as provided in paragraph (g), fundamental emissions from intentional radiators operating under this Section shall not be located in the frequency bands 54-72 MHz, 76-88 MHz, 174-216 MHz or 470-806 MHz. However, operation within these frequency bands is permitted under other sections of this Part, e.g., Sections 15.231 and 15.241.

2. In the above emission table, the tighter limit applies at the band edges.

Frequency (Hz)	Field Strength (μ V/m at 3-meter)	Field Strength (dB μ V/m at 3-meter)
30-88	100	40
88-216	150	43.5
216-960	200	46
Above 960	500	54



MEASUREMENT EQUIPMENT USED

Radiated Emission Test Site 966(2)					
Name of Equipment	Manufacturer	Model Number	Serial Number	Last Calibration	Due Calibration
PSA Series Spectrum Analyzer	Agilent	E4446A	US44300399	03/19/2012	03/19/2013
ESCI EMI TEST RECEIVER.ESCI	ROHDE&SCHWARZ	ESCI	100783	03/17/2012	03/17/2013
Amplifier	MITEQ	AM-1604-3000	1123808	03/18/2012	03/18/2013
Turn Table	EMCO	2081-1.21	N/A	N.C.R	N.C.R
Controller	CT	N/A	N/A	N.C.R	N.C.R
High Noise Amplifier	Agilent	8449B	3008A01838	03/18/2012	03/18/2013
Bilog Antenna	SCHAFFNER	CBL6143	5082	03/17/2012	03/17/2013
Horn Antenna	SCHWARZBECK	BBHA9120	D286	03/17/2012	03/17/2013
Loop Antenna	A. R. A	PLA-1030/B	1029	03/23/2012	03/23/2013
Temp. / Humidity Meter	VICTOR	VC230	N/A	03/19/2012	03/19/2013
Antenna Tower	SUNOL	TLT2	N/A	N.C.R	N.C.R
Test S/W	FARAD	LZ-RF / CCS-SZ-3A2			

Remark: Each piece of equipment is scheduled for calibration once a year.



Test Configuration

Below 1 GHz

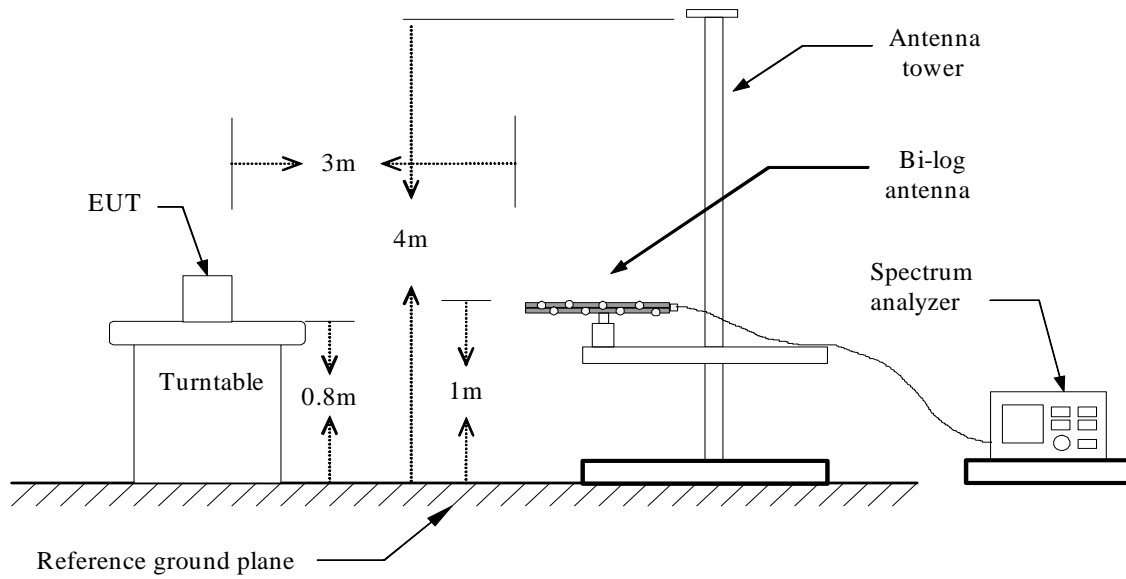

Above 1 GHz

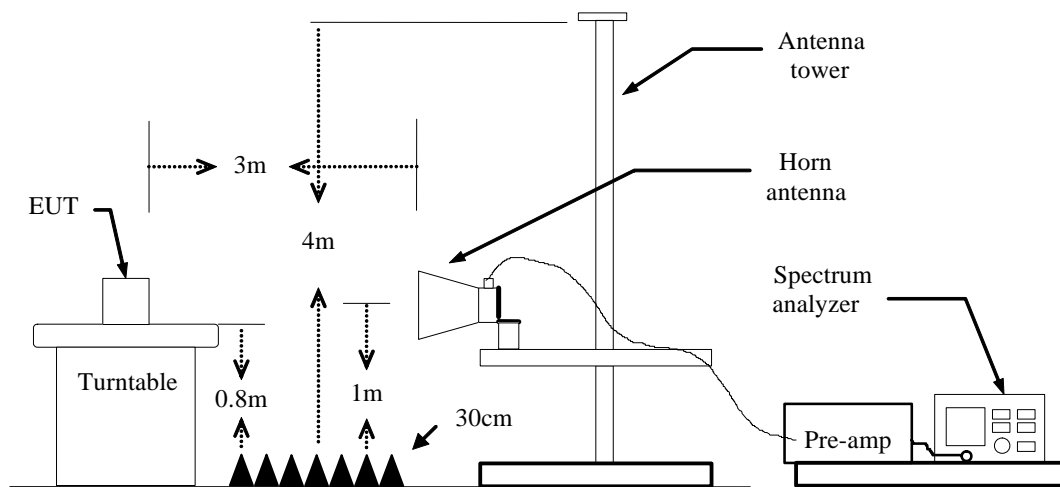



TEST PROCEDURE

1. The EUT is placed on a turntable, which is 0.8m above ground plane.
2. The turntable shall be rotated for 360 degrees to determine the position of maximum emission level.
3. EUT is set 3m away from the receiving antenna, which is varied from 1m to 4m to find out the highest emissions.
4. Maximum procedure was performed on the six highest emissions to ensure EUT compliance.
5. And also, each emission was to be maximized by changing the polarization of receiving antenna both horizontal and vertical.
6. Repeat above procedures until the measurements for all frequencies are complete.



TEST RESULTS

Below 1 GHz

Operation Mode: TX

Test Date: October 31,2012

Temperature: 24°C

Tested by: Leevin Li

Humidity: 52% RH

Polarity: Ver. / Hor.

Table with 8 columns: Frequency (MHz), Reading (dBµV), Correction Factor (dB/m), Result (dBµV/m), Limit (dBµV/m), Margin (dB), Antenna Pole (V/H), Remark. It contains 15 rows of test data.

**Remark: No emission found between lowest internal used/generated frequency to 30MHz.

Notes:

- 1. Measuring frequencies from 9kHz to the 1GHz.
2. Radiated emissions measured in frequency range from 30MHz to 1GHz were made with an instrument using Peak/Quasi-peak detector mode.
3. Data of measurement within this frequency range shown " --- " in the table above means the reading of emissions are attenuated more than 20dB below the permissible limits or the field strength is too small to be measured.
4. The IF bandwidth of SPA between 30MHz to 1GHz was 120kHz.
5. Frequency (MHz) = Emission frequency in MHz
Reading (dBuV) = Receiver reading
Correction Factor(dB/m) = Antenna factor + Cable loss – Amplifier gain
Actual FS (dBuV/m) = Reading (dBuV) + Corr. Factor (dB/m)
Limit (dBuV/m) = Limit stated in standard
Margin(dB) = Measured (dBuV/m) – Limits (dBuV/m)
Antenna Pole(V/H) = Current carrying line of reading



Above 1 GHz

GFSK

Operation

TX(CH Low)

Test Date: October 27,2012

Mode:

Temperature: 24°C

Tested by: Leevin Li

Humidity: 52% RH

Polarity: Ver. / Hor.

Frequency (MHz)	Reading (dBµV)	Correction Factor (dB/m)	Result (dBµV/m)	Limit (dBµV/m)	Margin (dB)	Antenna Pole (V/H)	Remark
1452.3600	55.66	-8.05	47.61	74.00	-26.39	V	peak
3407.4750	46.47	-3.96	42.51	74.00	-31.49	V	peak
4342.5300	46.00	-1.04	44.96	74.00	-29.04	V	peak
4965.9000	45.55	1.16	46.71	74.00	-27.29	V	peak
5305.9200	45.44	1.53	46.97	74.00	-27.03	V	peak
6949.3500	45.96	6.09	52.05	74.00	-21.95	V	peak
1452.3600	51.31	-8.05	43.26	74.00	-30.74	H	Peak
4370.8650	45.32	-0.93	44.39	74.00	-29.61	H	Peak
4880.8950	44.64	0.78	45.42	74.00	-28.58	H	Peak
5164.2450	45.48	1.51	46.99	74.00	-27.01	H	Peak
6042.6300	44.98	3.22	48.20	74.00	-25.80	H	Peak
7431.0450	45.09	7.61	52.70	74.00	-21.30	H	Peak

Notes:

1. Measuring frequencies from 1 GHz to the 10th harmonic of highest fundamental frequency.
2. Measurements above show only up to 6 maximum emissions noted, or would be lesser if no specific emissions from the EUT are recorded (ie: margin>20dB from the applicable limit) and considered that's already beyond the background noise floor.
3. Radiated emissions measured in frequency above 1000MHz were made with an instrument using Peak detector mode and average detector mode of the emission shown in Actual FS column.
4. Spectrum setting:
 - a. Peak Setting 1GHz - 26GHz, RBW = 1MHz, VBW = 1MHz, Sweep time = 200 ms.
 - b. AV Setting 1GH z- 26GHz, RBW = 1MHz, VBW = 10Hz, Sweep time = 200 ms.
5. Frequency (MHz) = Emission frequency in MHz
 Reading (dBµV/m) =Uncorrected Analyzer / Receiver Reading
 Correction Factor (dB) = Antenna factor + Cable loss – Amplifier gain
 Limit (dBµV/m) = Limit stated in standard
 Margin (dB) = Result (dBµV/m)- Limit (dBµV/m)
 Pk = Peak Reading
 AV. = Average Reading
 Remark = Mark Peak Reading or Average Reading



Operation Mode: TX(CH Mid)

Test Date: October 27,2012

Temperature: 24°C

Tested by: Leevin Li

Humidity: 52% RH

Polarity: Ver. / Hor.

Frequency (MHz)	Reading (dBµV)	Correction Factor (dB/m)	Result (dBµV/m)	Limit (dBµV/m)	Margin (dB)	Antenna Pole (V/H)	Remark
1452.3600	57.95	-8.05	49.90	74.00	-24.10	V	Peak
3265.8000	46.83	-4.06	42.77	74.00	-31.23	V	Peak
4144.1850	46.47	-1.85	44.62	74.00	-29.38	V	Peak
4824.2250	44.52	0.52	45.04	74.00	-28.96	V	Peak
5645.9400	45.45	2.13	47.58	74.00	-26.42	V	Peak
6552.6600	44.32	4.69	49.01	74.00	-24.99	V	Peak
1452.3600	49.60	-8.05	41.55	74.00	-32.45	H	Peak
3775.8300	45.96	-2.55	43.41	74.00	-30.59	H	Peak
4427.5350	45.73	-0.77	44.96	74.00	-29.04	H	Peak
5249.2500	45.33	1.54	46.87	74.00	-27.13	H	Peak
6099.3000	44.90	3.38	48.28	74.00	-25.72	H	Peak
7034.3550	45.17	6.53	51.70	74.00	-22.30	H	Peak

Notes:

1. Measuring frequencies from 1 GHz to the 10th harmonic of highest fundamental frequency.
2. Measurements above show only up to 6 maximum emissions noted, or would be lesser if no specific emissions from the EUT are recorded (ie: margin>20dB from the applicable limit) and considered that's already beyond the background noise floor.
3. Radiated emissions measured in frequency above 1000MHz were made with an instrument using Peak detector mode and average detector mode of the emission shown in Actual FS column.
4. Spectrum setting:
 - a. Peak Setting 1GHz - 26GHz, RBW = 1MHz, VBW = 1MHz, Sweep time = 200 ms.
 - b. AV Setting 1GH z- 26GHz, RBW = 1MHz, VBW = 10Hz, Sweep time = 200 ms.
5. Frequency (MHz) = Emission frequency in MHz
 Reading (dBµV/m) =Uncorrected Analyzer / Receiver Reading
 Correction Factor (dB) = Antenna factor + Cable loss – Amplifier gain
 Limit (dBµV/m) = Limit stated in standard
 Margin (dB) = Result (dBµV/m)- Limit (dBµV/m)
 Pk = Peak Reading
 AV = Average Reading
 Remark = Mark Peak Reading or Average Reading



Operation Mode: TX(CH High)

Test Date: October 27,2012

Temperature: 24 °C

Tested by: Leevin Li

Humidity: 52% RH

Polarity: Ver. / Hor.

Frequency (MHz)	Reading (dBµV)	Correction Factor (dB/m)	Result (dBµV/m)	Limit (dBµV/m)	Margin (dB)	Antenna Pole (V/H)	Remark
1452.3600	58.48	-8.05	50.43	74.00	-23.57	V	Peak
3010.7850	46.63	-4.23	42.40	74.00	-31.60	V	Peak
4144.1850	45.86	-1.85	44.01	74.00	-29.99	V	Peak
5249.2500	44.60	1.54	46.14	74.00	-27.86	V	Peak
6042.6300	44.85	3.22	48.07	74.00	-25.93	V	Peak
6949.3500	45.22	6.09	51.31	74.00	-22.69	V	Peak
1565.7000	49.04	-8.53	40.51	74.00	-33.49	H	Peak
3889.1700	47.22	-2.51	44.71	74.00	-29.29	H	Peak
4965.9000	45.08	1.16	46.24	74.00	-27.76	H	Peak
5702.6100	44.30	2.37	46.67	74.00	-27.33	H	Peak
6580.9950	44.20	4.77	48.97	74.00	-25.03	H	Peak
7204.3650	43.62	7.37	50.99	74.00	-23.01	H	Peak

Notes:

1. Measuring frequencies from 1 GHz to the 10th harmonic of highest fundamental frequency.
2. Measurements above show only up to 6 maximum emissions noted, or would be lesser if no specific emissions from the EUT are recorded (ie: margin>20dB from the applicable limit) and considered that's already beyond the background noise floor.
3. Radiated emissions measured in frequency above 1000MHz were made with an instrument using Peak detector mode and average detector mode of the emission shown in Actual FS column.
4. Spectrum setting:
 - a. Peak Setting 1GHz - 26GHz, RBW = 1MHz, VBW = 1MHz, Sweep time = 200 ms.
 - b. AV Setting 1GH z- 26GHz, RBW = 1MHz, VBW = 10Hz, Sweep time = 200 ms.
5. Frequency (MHz) = Emission frequency in MHz
 Reading (dBµV/m) =Uncorrected Analyzer / Receiver Reading
 Correction Factor (dB) = Antenna factor + Cable loss – Amplifier gain
 Limit (dBµV/m) = Limit stated in standard
 Margin (dB) = Result (dBµV/m)- Limit (dBµV/m)
 Pk = Peak Reading
 AV = Average Reading
 Remark = Mark Peak Reading or Average Reading



8DPSK

Operation Mode:

TX(CH Low)

Test Date: October 27,2012

Temperature: 24°C

Tested by: Leevin Li

Humidity: 52% RH

Polarity: Ver. / Hor.

Frequency (MHz)	Reading (dBµV)	Correction Factor (dB/m)	Result (dBµV/m)	Limit (dBµV/m)	Margin (dB)	Antenna Pole (V/H)	Remark
1254.0150	55.94	-8.49	47.45	74.00	-26.55	V	Peak
1452.3600	55.94	-8.05	47.89	74.00	-26.11	V	Peak
2699.1000	48.29	-5.44	42.85	74.00	-31.15	V	Peak
3662.4900	46.25	-2.85	43.40	74.00	-30.60	V	Peak
4994.2350	45.63	1.29	46.92	74.00	-27.08	V	Peak
6836.0100	43.72	5.62	49.34	74.00	-24.66	V	Peak
1367.3550	48.64	-7.98	40.66	74.00	-33.34	H	Peak
2982.4500	47.71	-4.31	43.40	74.00	-30.60	H	Peak
4314.1950	45.63	-1.15	44.48	74.00	-29.52	H	Peak
5815.9500	44.41	2.80	47.21	74.00	-26.79	H	Peak
6580.9950	45.73	4.77	50.50	74.00	-23.50	H	Peak
6836.0100	45.17	5.62	50.79	74.00	-23.21	H	Peak

Notes:

1. Measuring frequencies from 1 GHz to the 10th harmonic of highest fundamental frequency.
2. Measurements above show only up to 6 maximum emissions noted, or would be lesser if no specific emissions from the EUT are recorded (ie: margin>20dB from the applicable limit) and considered that's already beyond the background noise floor.
3. Radiated emissions measured in frequency above 1000MHz were made with an instrument using Peak detector mode and average detector mode of the emission shown in Actual FS column.
4. Spectrum setting:
 - a. Peak Setting 1GHz - 26GHz, RBW = 1MHz, VBW = 1MHz, Sweep time = 200 ms.
 - b. AV Setting 1GH z- 26GHz, RBW = 1MHz, VBW = 10Hz, Sweep time = 200 ms.
5. Frequency (MHz) = Emission frequency in MHz
 Reading (dBµV/m) =Uncorrected Analyzer / Receiver Reading
 Correction Factor (dB) = Antenna factor + Cable loss – Amplifier gain
 Limit (dBµV/m) = Limit stated in standard
 Margin (dB) = Result (dBµV/m)- Limit (dBµV/m)
 Pk = Peak Reading
 AV. = Average Reading
 Remark = Mark Peak Reading or Average Reading



Operation Mode: TX(CH Mid)

Test Date: October 27,2012

Temperature: 24°C

Tested by: Leevin Li

Humidity: 52% RH

Polarity: Ver. / Hor.

Frequency (MHz)	Reading (dBµV)	Correction Factor (dB/m)	Result (dBµV/m)	Limit (dBµV/m)	Margin (dB)	Antenna Pole (V/H)	Remark
1452.3600	57.61	-8.05	49.56	74.00	-24.44	V	Peak
2897.4450	47.14	-4.65	42.49	74.00	-31.51	V	Peak
4285.8600	45.28	-1.25	44.03	74.00	-29.97	V	Peak
5050.9050	45.75	1.38	47.13	74.00	-26.87	V	Peak
5504.2650	45.80	1.73	47.53	74.00	-26.47	V	Peak
6155.9700	44.04	3.55	47.59	74.00	-26.41	V	Peak
1452.3600	49.00	-8.05	40.95	74.00	-33.05	H	Peak
2982.4500	46.55	-4.31	42.24	74.00	-31.76	H	Peak
3804.1650	45.30	-2.49	42.81	74.00	-31.19	H	Peak
4200.8550	45.70	-1.58	44.12	74.00	-29.88	H	Peak
5079.2400	44.95	1.41	46.36	74.00	-27.64	H	Peak
5844.2850	44.75	2.85	47.60	74.00	-26.40	H	Peak

Notes:

- Measuring frequencies from 1 GHz to the 10th harmonic of highest fundamental frequency.
- Measurements above show only up to 6 maximum emissions noted, or would be lesser if no specific emissions from the EUT are recorded (ie: margin>20dB from the applicable limit) and considered that's already beyond the background noise floor.
- Radiated emissions measured in frequency above 1000MHz were made with an instrument using Peak detector mode and average detector mode of the emission shown in Actual FS column.
- Spectrum setting:
 - Peak Setting 1GHz - 26GHz, RBW = 1MHz, VBW = 1MHz, Sweep time = 200 ms.
 - AV Setting 1GH z- 26GHz, RBW = 1MHz, VBW = 10Hz, Sweep time = 200 ms.
- Frequency (MHz) = Emission frequency in MHz

Reading (dBµV/m) =Uncorrected Analyzer / Receiver Reading

Correction Factor (dB) = Antenna factor + Cable loss – Amplifier gain

Limit (dBµV/m) = Limit stated in standard

Margin (dB) = Result (dBµV/m)- Limit (dBµV/m)

Pk = Peak Reading

AV = Average Reading

Remark = Mark Peak Reading or Average Reading



Operation Mode: TX(CH High)

Test Date: October 27,2012

Temperature: 24 °C

Tested by: Leevin Li

Humidity: 52% RH

Polarity: Ver. / Hor.

Frequency (MHz)	Reading (dBµV)	Correction Factor (dB/m)	Result (dBµV/m)	Limit (dBµV/m)	Margin (dB)	Antenna Pole (V/H)	Remark
1254.0150	55.65	-8.49	47.16	74.00	-26.84	V	Peak
1480.6950	57.49	-8.17	49.32	74.00	-24.68	V	Peak
4229.1900	45.57	-1.47	44.10	74.00	-29.90	V	Peak
4739.2200	44.55	0.15	44.70	74.00	-29.30	V	Peak
5815.9500	44.49	2.80	47.29	74.00	-26.71	V	Peak
6495.9900	44.20	4.53	48.73	74.00	-25.27	V	Peak
1339.0200	48.27	-8.10	40.17	74.00	-33.83	H	Peak
3265.8000	46.69	-4.06	42.63	74.00	-31.37	H	Peak
4144.1850	45.00	-1.85	43.15	74.00	-30.85	H	Peak
5220.9150	45.36	1.55	46.91	74.00	-27.09	H	Peak
5929.2900	45.54	2.98	48.52	74.00	-25.48	H	Peak
7147.6950	44.08	7.10	51.18	74.00	-22.82	H	Peak

Notes:

1. Measuring frequencies from 1 GHz to the 10th harmonic of highest fundamental frequency.
2. Measurements above show only up to 6 maximum emissions noted, or would be lesser if no specific emissions from the EUT are recorded (ie: margin>20dB from the applicable limit) and considered that's already beyond the background noise floor.
3. Radiated emissions measured in frequency above 1000MHz were made with an instrument using Peak detector mode and average detector mode of the emission shown in Actual FS column.
4. Spectrum setting:
 - a. Peak Setting 1GHz - 26GHz, RBW = 1MHz, VBW = 1MHz, Sweep time = 200 ms.
 - b. AV Setting 1GH z- 26GHz, RBW = 1MHz, VBW = 10Hz, Sweep time = 200 ms.
5. Frequency (MHz) = Emission frequency in MHz
 Reading (dBµV/m) =Uncorrected Analyzer / Receiver Reading
 Correction Factor (dB) = Antenna factor + Cable loss – Amplifier gain
 Limit (dBµV/m) = Limit stated in standard
 Margin (dB) = Result (dBµV/m)- Limit (dBµV/m)
 Pk = Peak Reading
 AV. = Average Reading
 Remark = Mark Peak Reading or Average Reading



6.9 POWERLINE CONDUCTED EMISSIONS

LIMIT

For an intentional radiator which is designed to be connected to the public utility (AC) power line, the radio frequency voltage that is conducted back onto the AC power line on any frequency or frequencies within the band 150 kHz to 30 MHz shall not exceed 250 microvolts (The limit decreases linearly with the logarithm of the frequency in the range 0.15 MHz to 0.50 MHz). The limits at specific frequency range is listed as follows:

Frequency Range (MHz)	Limits (dBµV)	
	Quasi-peak	Average
0.15 to 0.50	66 to 56	56 to 46
0.50 to 5	56	46
5 to 30	60	50

Compliance with this provision shall be based on the measurement of the radio frequency voltage between each power line (LINE and NEUTRAL) and ground at the power terminals.

MEASUREMENT EQUIPMENT USED

Conducted Emission Test Site					
Name of Equipment	Manufacturer	Model Number	Serial Number	Last Calibration	Due Calibration
ESCI EMI TEST RECEIVER.ESCI	ROHDE&SCHWARZ	ESCI	100783	03/17/2012	03/17/2013
LISN (EUT)	SCHAFFNER	NNB42	2001/001	03/19/2012	03/19/2013
LISN	EMCO	3825/2	8901-1459	03/19/2012	03/19/2013
Temp. / Humidity Meter	VICTOR	HTC-1	2	03/20/2012	03/20/2013
Test S/W	FARAD	EZ-EMC/ CCS-3A1-CE			

Remark: Each piece of equipment is scheduled for calibration once a year.



Test Configuration

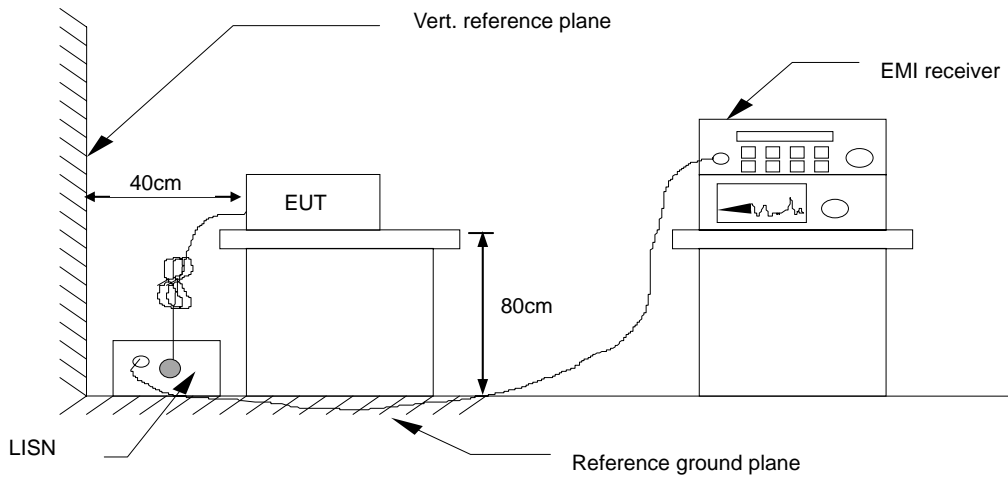

See test photographs attached in Appendix 1 for the actual connections between EUT and support equipment.

TEST PROCEDURE

1. The EUT was placed on a table, which is 0.8m above ground plane.
2. Maximum procedure was performed on the six highest emissions to ensure EUT compliance.
3. Repeat above procedures until all frequency measured were complete.

TEST RESULTS

Not applicable, since the EUT powered by DC power.