



WARNING



Study, understand and follow all instructions provided with this product. Read these instructions carefully before installing, operating, servicing or repairing this tool. Keep these instructions in a safe, accessible place.

Caution: To help prevent personal injury,

- Never use this tool for any application other than for which it was designed.
- Never alter or modify this tool in any way. Improper operation and / or maintenance of the tool, or modification of the tool could result in serious injury or death.
- Always perform automotive testing in a safe environment.
- Do not attempt to operate or observe the tool while driving a vehicle. Operating or observing the tool will cause driver distraction and could cause a fatal accident.
- Wear safety eye protection that meets ANSI standards.
- Keep clothing, hair, hands, tools, test equipment, etc. away from all moving or hot engine parts.
- Operate the vehicle in a well-ventilated work area: Exhaust gases are poisonous.
- Put blocks in front of the drive wheels and never leave the vehicle unattended while running tests.
- Use extreme caution when working around the ignition coil, distributor cap, ignition wires and spark plugs. These components create hazardous voltages when the engine is running.
- Put the transmission in P (for A/T) or N (for M/T), and make sure the parking brake is engaged.
- Keep a fire extinguisher suitable for gasoline / chemical / electrical fires nearby.
- Don't connect or disconnect any test equipment while the ignition is on or the engine is running.
- Keep this tool dry, clean, free from oil / water or grease. Use a mild detergent on a clean cloth to clean the outside of the tool, when necessary.

FCC STATEMENT

Any Changes or modifications not expressly approved by the party responsible for compliance could void the user's authority to operate the equipment.

This device complies with part 15 of the FCC Rules. Operation is subject to the following two conditions: (1) This device may not cause harmful interference, and (2) this device must accept any interference received, including interference that may cause undesired operation.

Note: This equipment has been tested and found to comply with the limits for a Class B digital device, pursuant to Part 15 of the FCC Rules. These limits are designed to provide reasonable protection against harmful interference in a residential installation.

This equipment generates, uses, and can radiate radio frequency energy, and if not installed and used in accordance with the instructions, may cause harmful interference to radio communications. However, there is no guarantee that interference will not occur in a particular installation. If this equipment does cause harmful interference to radio or television reception, which can be determined by turning the equipment off and on, the user is encouraged to try to correct the interference by one or more of the following measures:

- Reorient or relocate the receiving antenna.
- Increase the separation between the equipment and receiver.
- Connect the equipment into an outlet on a circuit different from that to which the receiver is connected.
- Consult the dealer or an experienced radio / TV technician for help.

Table of Contents

1. Introduction	1
2. General Information	3
2.1 On-Board Diagnostics (OBD) II	3
2.2 Diagnostic Trouble Codes (DTCs).....	3
2.3 Location of the Data Link Connector (DLC).....	4
2.4 OBD II Readiness Monitors	5
2.5 OBD II Monitor Readiness Status.....	6
2.6 OBD II Definitions	6
3. Product Descriptions	8
3.1 Components & Controls	8
3.2 Technical Specifications	9
3.3 Accessories Checklist.....	9
4. Initial Use	10
4.1 Powering Up The Tool	10
4.2 Getting Started	10
4.3 Job Menu.....	11
5. Diagnose	13
5.1 Connection	13
5.2 System Diagnosing.....	14
5.2.1 Smart Diagnosis (Auto-Detect).....	14
5.2.2 Manual Diagnosis	15
5.3 OBDII Diagnosis	23
5.4 History	25
5.5 Reset (Special Functions)	26
5.5.1 Download reset software	26
5.5.2 How to perform reset procedures?.....	27
6. Upgrade	28
7. Mail	29
8. Settings	30
8.1 Units of measurement	30

8.2 Automatic detection on connect.....	30
8.3 Brightness.....	30
8.4 Sound	30
8.5 Network	30
8.6 Time Zone.....	30
8.7 Language.....	30
8.8 Workshop information.....	31
8.9 Recovery	31
8.10 Clean Up.....	31
8.11 Screen Capture.....	31
8.12 About	31
8.13 Data	31
8.13.1 Diagnostic Record	31
8.13.2 Diagnostic Report.....	32
8.13.3 DTC Library	32
8.13.4 DLC (Data Link Connector) Location.....	33
8.13.5 Image.....	33
8.13.6 Feedback.....	33
8.13.7 Firmware Fix.....	34
8.13.8 User Manual	34
9. FAQ	35

1. Introduction

Creader Elite 200/202/205 is an evolutionary smart code reader for professional technicians or DIYers. It only applies to the passenger cars with 12V battery voltage.

It has the following functions and advantages:

- **Smart(Auto-Detect) Diagnosis:** Once the tool and the vehicle are properly connected, the system starts auto-detect process. Once the whole process is successfully finished, a diagnostic report will be automatically generated.
- **Manual Diagnosis:** If Auto-Detect failure occurs, manual diagnosis is also available. Diagnosis functions include: Version Information, Read DTCs, Clear DTCs and Read Data Stream (supports 3 display modes: Value, Graph and Merged).
- **OBD II Diagnosis:** 10 modes of OBD II test are supported, including EVAP, O2 Sensor, I/M Readiness, MIL Status, VIN Info, and On-board monitors testing etc.
- **Reset:** This function allows you to perform different kinds of common special functions.
- **One-Click Update:** Let you update your diagnostic software and APK online.
- **Mail:** This function allows you to purchase more diagnostic software with full system and full functions that are not pre-installed on this tool.
- **Diagnostic History:** This function provides a quick access to the tested vehicles and users can choose to view the test report or resume from the last operation, without starting from scratch.
- **Diagnostic Feedback:** Use this option to submit the vehicle issue to us for analysis and troubleshooting.
- **DTC Library:** Allows you to retrieve the definition of the diagnostic trouble code from the abundant DTC database.
- Displays battery real-time voltage once properly connected to the vehicle.

This tool is specially designed to work with all OBD II compliant vehicles, including Controller Area Network (CAN). It is required by EPA that all 1996 and newer vehicles (cars and light trucks) sold in the United States must be OBD II compliant and this includes all American, Asian and European vehicles.

A small number of 1994 and 1995 model year gasoline vehicles are OBD II compliant. To verify if a 1994 or 1995 vehicle is OBD II compliant, check the following:

1. Vehicle Emissions Control Information (VECI) Label. It is located under the hood or by the radiator of most vehicles. If the vehicle is OBD II compliant,

the label will designate “OBD II Certified”.

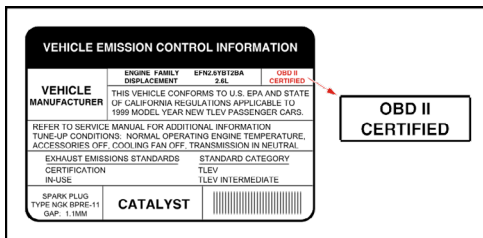

- Government regulations mandate that all OBD II compliant vehicles must have a “common” 16-pin Data Link Connector (DLC).

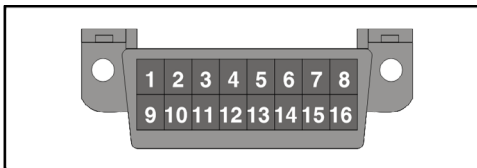

 Note: Some 1994 and 1995 vehicles have 16-pin connectors but are not OBD II compliant. Only those vehicles with a Vehicle Emissions Control Label stating “OBD II Certified” are OBD II compliant.

2. General Information

2.1 On-Board Diagnostics (OBD II)

The first generation of On-Board Diagnostics (OBD I) was developed by the California Air Resources Board (ARB) and implemented in 1988 to monitor some of the emission control components on vehicles. As technology evolved and the desire to improve the On-Board Diagnostic system increased, a new generation of On-Board Diagnostic system was developed. This second generation of On-Board Diagnostic regulations is called "OBD II".

The OBD II system is designed to monitor emission control systems and key engine components by performing either continuous or periodic tests of specific components and vehicle conditions. When a problem is detected, the OBD II system turns on a warning lamp (MIL) on the vehicle instrument panel to alert the driver typically by the phrase of "Check Engine" or "Service Engine Soon". The system will also store important information about the detected malfunction so that a technician can accurately find and fix the problem. Here below follow three pieces of such valuable information:

- 1) Whether the Malfunction Indicator Light (MIL) is commanded 'on' or 'off';
- 2) Which, if any, Diagnostic Trouble Codes (DTCs) are stored;
- 3) Readiness Monitor status.

2.2 Diagnostic Trouble Codes (DTCs)

OBD II Diagnostic Trouble Codes are codes that are stored by the on-board computer diagnostic system in response to a problem found in the vehicle. These codes identify a particular problem area and are intended to provide you with a guide as to where a fault might be occurring within a vehicle. OBD II Diagnostic Trouble Codes consist of a five-digit alphanumeric code. The first character, a letter, identifies which control system sets the code. The second character, a number, 0-3; other three characters, a hex character, 0-9 or A-F provide additional information on where the DTC originated and the operating conditions that caused it to set. Here below is an example to illustrate the structure of the digits:

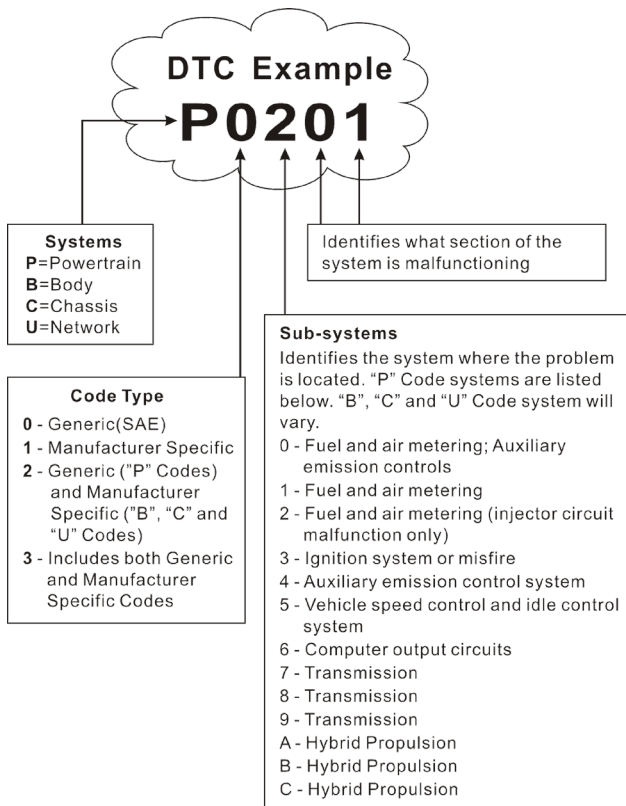

Figure 2-1 (P0201 - Injector circuit malfunction, Cylinder 1)

2.3 Location of the Data Link Connector (DLC)

The DLC (Data Link Connector or Diagnostic Link Connector) is typically a 16-pin connector where diagnostic code readers interface with the vehicle's on-board computer. The DLC is usually located 12 inches from the center of the instrument panel (dash), under or around the driver's side for most vehicles. If Data Link Connector is not located under dashboard, a label should be there telling location. For some Asian and European vehicles, the DLC is located behind the ashtray and the ashtray must be removed to access the connector. If

the DLC cannot be found, refer to the vehicle's service manual for the location.

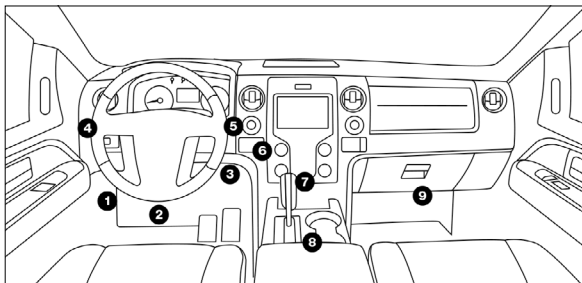

Figure 2-2

2.4 OBD II Readiness Monitors

An important part of a vehicle's OBD II system is the Readiness Monitors, which are indicators used to find out if all of the emissions components have been evaluated by the OBD II system. They are running periodic tests on specific systems and components to ensure that they are performing within allowable limits.

Currently, there are eleven OBD II Readiness Monitors (or I/M Monitors) defined by the U.S. Environmental Protection Agency (EPA). Not all monitors are supported in every vehicles and the exact number of monitors in any vehicle depends on the motor vehicle manufacturer's emissions control strategy.

Continuous Monitors -- Some of the vehicle components or systems are continuously tested by the vehicle's OBD II system, while others are tested only under specific vehicle operating conditions. The continuously monitored components listed below are always ready:

1. Misfire
2. Fuel System
3. Comprehensive Components (CCM)

Once the vehicle is running, the OBD II system is continuously checking the above components, monitoring key engine sensors, watching for engine misfire, and monitoring fuel demands.

Non-Continuous Monitors -- Unlike the continuous monitors, many emissions and engine system components require the vehicle to be operated under specific conditions before the monitor is ready. These monitors are termed non-continuous monitors and are listed below:

- 1) EGR System

- 2) O2 Sensors
- 3) Catalyst
- 4) Evaporative System
- 5) O2 Sensor Heater
- 6) Secondary Air Injection
- 7) Heated Catalyst
- 8) A/C system

2.5 OBD II Monitor Readiness Status

OBD II systems must indicate whether or not the vehicle's PCM's monitor system has completed testing on each component. Components that have been tested will be reported as "Ready", or "Complete", meaning they have been tested by the OBD II system. The purpose of recording readiness status is to allow inspectors to determine if the vehicle's OBD II system has tested all the components and / or systems.

The Powertrain Control Module (PCM) sets a monitor to "Ready" or "Complete" after an appropriate drive cycle has been performed. The drive cycle that enables a monitor and sets readiness codes to "Ready" varies for each individual monitor. Once a monitor is set as "Ready" or "Complete", it will remain in this state. A number of factors, including erasing of Diagnostic Trouble Codes (DTCs) with a code reader or a disconnected battery, can result in Readiness Monitors being set to "Not Ready". Since the three continuous monitors are constantly evaluating, they will be reported as "Ready" all of the time. If testing of a particular supported non-continuous monitor has not been completed, the monitor status will be reported as "Not Complete" or "Not Ready."

In order for the OBD monitor system to become ready, the vehicle should be driven under a variety of normal operating conditions. These operating conditions may include a mix of highway driving and stop and go, city type driving, and at least one overnight-off period. For specific information on getting your vehicle's OBD monitor system ready, please consult your vehicle owner's manual.

2.6 OBD II Definitions

Powertrain Control Module (PCM) -- OBD II terminology for the on-board computer that controls engine and drive train.

Malfunction Indicator Light (MIL) -- Malfunction Indicator Light (Service Engine Soon, Check Engine) is a term used for the light on the instrument panel. It is to alert the driver and / or the repair technician that there is a problem with one or more of vehicle's systems and may cause emissions to exceed federal

standards. If the MIL illuminates with a steady light, it indicates that a problem has been detected and the vehicle should be serviced as soon as possible. Under certain conditions, the dashboard light will blink or flash. This indicates a severe problem and flashing is intended to discourage vehicle operation. The vehicle onboard diagnostic system cannot turn the MIL off until the necessary repairs are completed or the condition no longer exists.

DTC -- Diagnostic Trouble Codes (DTC) that identifies which section of the emission control system has malfunctioned.

Enabling Criteria -- Also termed Enabling Conditions. They are the vehicle-specific events or conditions that must occur within the engine before the various monitors will set, or run. Some monitors require the vehicle to follow a prescribed "drive cycle" routine as part of the enabling criteria. Drive cycles vary among vehicles and for each monitor in any particular vehicle. Please refer to the vehicle's factory service manual for specific enabling procedures.

OBD II Drive Cycle -- A specific mode of vehicle operation that provides conditions required to set all the readiness monitors applicable to the vehicle to the "ready" condition. The purpose of completing an OBD II drive cycle is to force the vehicle to run its onboard diagnostics. Some form of a drive cycle needs to be performed after DTCs have been erased from the PCM's memory or after the battery has been disconnected. Running through a vehicle's complete drive cycle will "set" the readiness monitors so that future faults can be detected. Drive cycles vary depending on the vehicle and the monitor that needs to be reset. For vehicle specific drive cycle, consult the service manual.

Freeze Frame Data -- When an emissions related fault occurs, the OBD II system not only sets a code but also records a snapshot of the vehicle operating parameters to help in identifying the problem. This set of values is referred to as Freeze Frame Data and may include important engine parameters such as engine RPM, vehicle speed, air flow, engine load, fuel pressure, fuel trim value, engine coolant temperature, ignition timing advance, or closed loop status.

Fuel Trim (FT) - Feedback adjustments to the base fuel schedule. Short-term fuel trim refers to dynamic or instantaneous adjustments. Long-term fuel trim refers to much more gradual adjustments to the fuel calibration schedule than short-term trim adjustments. These long-term adjustments compensate for vehicle differences and gradual changes that occur over time.

3. Product Descriptions

3.1 Components & Controls

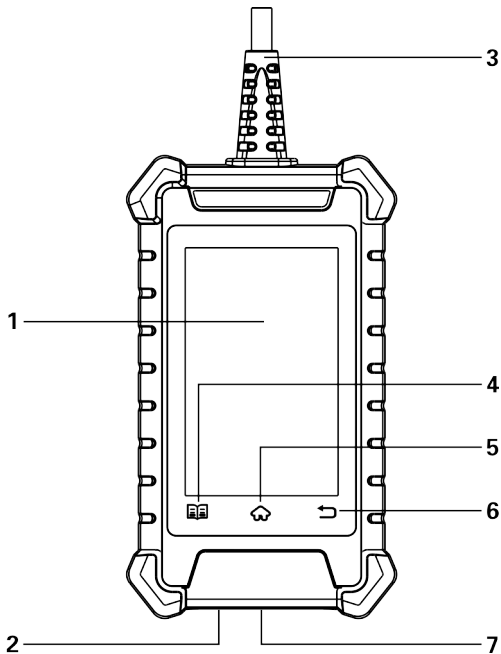





Figure 3-1

No.	Name	Descriptions
1	Touch screen	Indicates the test results.
2	Charging port	Connects it to the PC via the data cable to get power.
3	Diagnostic cable	Connects it to the vehicle's DLC port to power up the tool.

4	 Settings button	Quick dial to the Settings module.
5	 HOME button	Press to the home (Job menu) screen.
6	 BACK button	Exit the current program or return to the previous screen.
7	Memory card slot	Current disabled and only reserved for future use.

3.2 Technical Specifications

- Screen: 4" touch screen with a resolution of 480*800
- CPU: 4-core 1.3GHz processor
- RAM: 1GB
- ROM: 16GB
- WiFi: 802.11b/g/n 2.4GHz
- USB: TYPE C
- OBD II input voltage range: 9~18V
- Power up via:
 - DC 5V data cable or
 - Diagnostic cable through connection to vehicle's DLC
- Working temperature: -10 to 50°C (14 to 122 F°)
- Storage temperature: -20 to 70°C (-4 to 158 F°)

3.3 Accessories Checklist

For detailed accessory items, please consult from the local agency.

1. Creader Elite 200/202/205 tool
2. Data cable
3. User manual
4. Quick Start Guide

4. Initial Use

4.1 Powering Up The Tool

There are two methods available for powering up the tool:

Via Data Cable: Plug one end of the included data cable into the charging port of the tool, and the other end to the PC.

Via Diagnostic Cable: Insert the diagnostic cable into the vehicle's DLC port.

When the tool is powered on, the screen will automatically light up.

4.2 Getting Started

If it is the first time you have used this tool, you need to make some system settings.

1. Power on the tool. The screen displays a welcome page. Tap "Start" to go to next step.
2. Choose the desired system language, and tap "Next".
3. Choose the desired time zone, and tap "Next" to enter the WLAN setup screen.
4. Slide the switch to ON, the system starts searching for all available wireless LANs. Choose the desired WLAN access point / network,

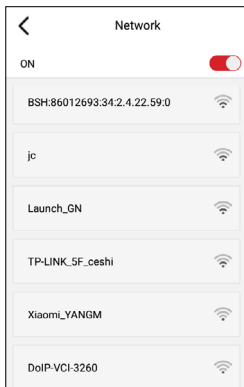



Fig. 4-1

- If the network you chose is open, you can connect directly.
- If the selected network is encrypted, you have to enter the right security

key (network password).

 Note: If you choose “Ignore” in WLAN setup, it will go into the date setting page. If the tool has been properly connected to the Internet, the system will automatically obtain the correct network date and time and navigate to step 5.

5. After the network connection is done, tap “Next Step” to configure workshop information. Input the required information, and tap “Next Step” to go to next step.

 Note: After you configured it, the system will append it on the report every time a report is successfully generated.

6. Carefully read all terms and conditions of the user agreement, check the box before the “Agree to all the above terms”, and tap “OK” finish the sign-up process and navigate to Job Menu.

4.3 Job Menu

It mainly includes the following function modules.

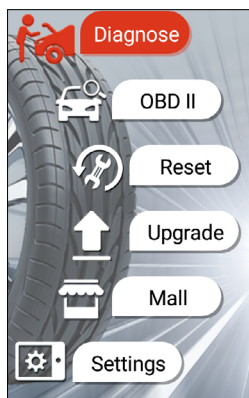



Fig. 4-2

Diagnose	Configures the tool to operate as a professional diagnostic tool.
-----------------	---

OBD II	This option presents a quick way to check for DTCs, isolate the cause of the illuminated Malfunction Indicator Lamp (MIL), check monitor status prior to emissions certification testing, verify repairs, and perform a number of other services that are emission-related.
Reset	This function allows you to perform different kinds of common special functions. Refer to Chapter 5.5 for details.
Upgrade	To update vehicle diagnostic software and APK.  Note: This function requires a stable network connection.
Mall	To subscribe extra vehicle diagnostic software or reset (special function) software that are not included within the tool.
Settings	To manage data and make some system settings, including Network setup, Workshop information and Brightness etc.

5. Diagnose

5.1 Connection

1. Turn the ignition off.

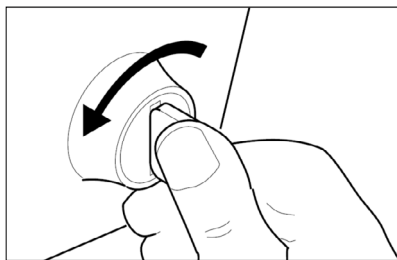

Figure 5-1

2. Locate vehicle's DLC port. See Figure 2-2 for possible DLC location.
3. Plug the diagnostic cable into the vehicle's DLC port.

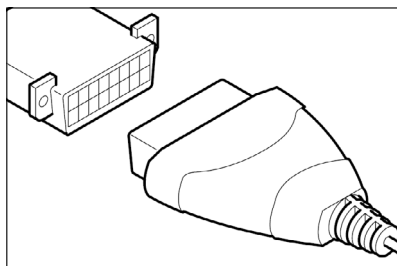

Figure 5-2

Notes:

- A plastic DLC cover may be found for some vehicles and you need to remove it before plugging the diagnostic cable.
 - The cable connector is keyed and will only fit one way. If you have problems connecting the cable connector to the DLC, rotate the connector 180° and try again.
-

5.2 System Diagnosing

This function is specially designed to diagnose electronic control systems of single vehicle model. Only two vehicle systems are supported: ABS (Anti-lock Braking System) and SRS (Supplemental Inflatable Restraint System).

5.2.1 Smart Diagnosis (Auto-Detect)

After connection, turn the ignition key on and the system enters auto-detect mode (🔧 Note: Please make sure the “Automatic detection on connect” in “Settings” is set as ON).

🔧 Note: To detect more and accurate VINs, a stable network connection is highly recommended for this function.

⚠ CAUTION: Don't connect or disconnect any test equipment with ignition on or engine running.

- Once the system successfully obtains the VIN (Vehicle Identification Number) information of the currently identified vehicle, it will continue scanning the vehicle systems. After the scanning is complete, a diagnostic report will be automatically generated in the **Settings -> Data -> Diagnostic Report**.
- If the tool failed to access the VIN information, the following popup will appear on the screen:

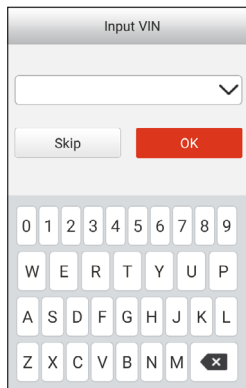

Fig. 5-3

Input the VIN, and tap “OK”, the system will automatically identify the vehicle model. If the vehicle VIN is successfully decoded, it will perform auto-

diagnosis until a diagnostic report is automatically output. Otherwise it will enter manual diagnosis mode. For details on manual diagnosis, see Chapter 5.2.2.

 Notes:

- The most recognizable location for this number is in the top left corner on the vehicle's dashboard. Other locations include the driver's door or post, and the firewall under the hood.
 - In general, vehicle identification numbers are standardized - all contain 17 characters. VIN characters may be capital letters A through Z and numbers 1 through 0; however, the letters I, O and Q are never used in order to avoid mistakes of misreading. No signs or spaces are allowed in the VIN.
-

5.2.2 Manual Diagnosis

If the tool can not obtain the VIN information, you can also perform vehicle diagnosis manually. In this mode, you need to execute the menu-driven command and then follow the on-screen instruction to proceed.

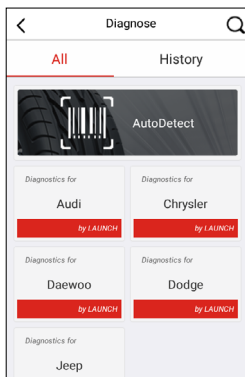

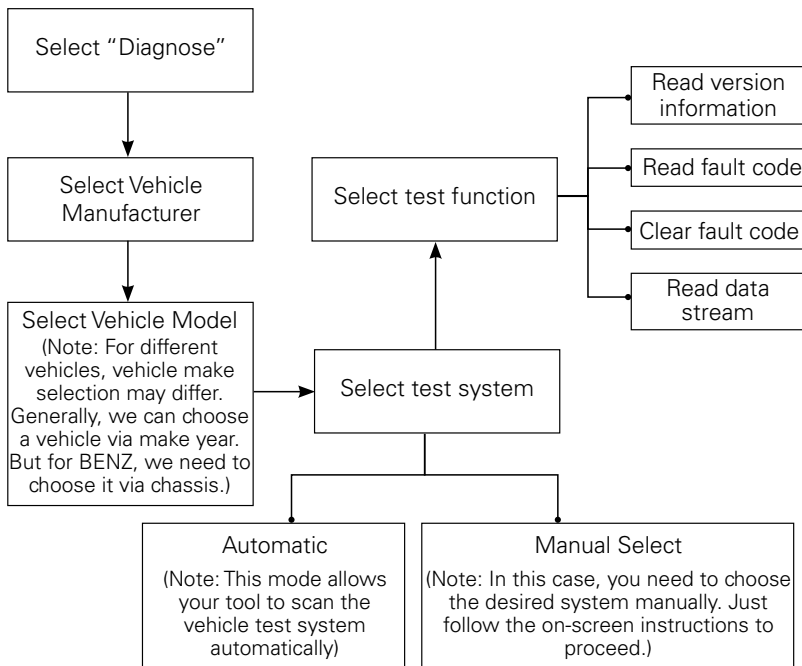



Fig. 5-4

 Note: For vehicles manufactured by different vendors, it is possible that it has different diagnostic menus. For details, please follow the instructions on the screen to proceed.

Refer to the flowchart illustrated as below to diagnose a vehicle manually:



Take Audi as an example to demonstrate how to diagnose a vehicle.

 Note: Illustrations used in this manual are samples, the actual testing screen may vary for each vehicle being tested. The following illustrations are based on the Audi with full systems. Vehicle diagnostic software with full systems and full functions can be purchased in the Mall.

- 1). Select diagnostic software version: Tap "Audi" to go to Step 2.
- 2). Select test item: Select the desired test item to proceed.

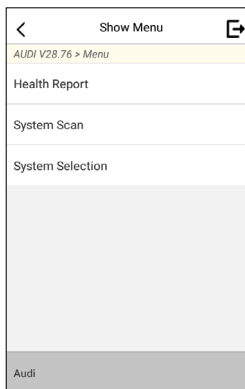

Fig. 5-5

5.2.2.1 Health Report (Quick Test)

This function varies from vehicle to vehicle. It enables you to quickly access all the electronic control units of the vehicle and generate a detailed report about vehicle health.

Tap “Health Report”, the system starts scanning the ECUs. Once the scanning is complete, the following screen will appear:

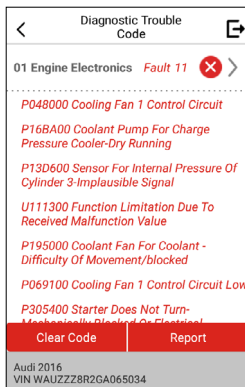

Fig. 5-6

In above figure, the tested system with fault code appears in red and the system with OK displays in black (normally).

On-Screen Buttons:

▼: Tap to display the details of DTCs existing in the current system. Tap ▲ to hide it.

Enter: Tap to select other test functions. For detailed operations, refer to Chapter 5.2.2.2 “System Selection”.

Report: Tap to save the diagnostic result as a report.

Clear DTC: Tap to clear the existing diagnostic trouble codes.

5.2.2.2 System Selection

This option allows you manually select the test system and function step by step. In Fig. 5-5, tap “System Selection”, and tap the desired system (take “ABS” for example) to jump to the test function page.

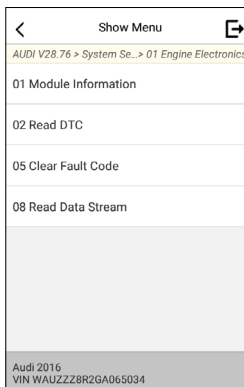



Fig. 5-7

 Note: Different vehicle has different diagnostic menus.

A. Version Information

This function is used to read the version information of system mode, vehicle VIN, software and ECU.

B. Read Fault Code

This function displays the detailed information of DTC records retrieved from the vehicle's control system.

In Fig. 5-7, tap “Read Fault Code”, the screen will display the diagnostic result.

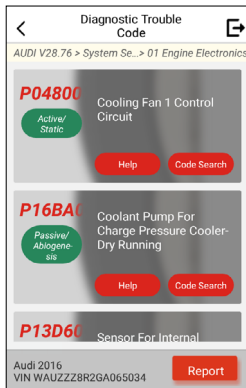



Fig. 5-8

 Note: Retrieving and using DTCs for troubleshooting vehicle operation is only one part of an overall diagnostic strategy. Never replace a part based only on the DTC definition. Each DTC has a set of testing procedures, instructions and flow charts that must be followed to confirm the location of the problem. This information can be found in the vehicle's service manual.

On-Screen Buttons:

Help: Tap to view the help information.

Code Search: Tap it to search for more information about the current DTC online.

Report: To save the current data in text format. All diagnostic reports can be accessed from **Settings -> Data -> Diagnostic Report**.

C. Clear Fault Code

After reading the retrieved codes from the vehicle and certain repairs have been carried out, you can use this function to erase the codes from the vehicle. Before performing this function, please be sure the vehicle's ignition key is in the ON position with the engine off.

E Notes:

1. If you plan to take the vehicle to a Service Center for repair, DO NOT erase the codes from the vehicle's computer. If data is erased, valuable information that might help the technician troubleshoot the problem will also be erased.
2. Clearing DTCs does not fix the problem(s) that caused the code(s) to be set. If proper repairs to correct the problem that caused the code(s) to be set are not made, the code(s) will appear again and the check engine light will illuminate as soon as the problem that cause the DTC to set manifests itself.

D. Read Data Stream

This option retrieves and displays live data and parameters from the vehicle's ECU.

In Fig. 5-7, tap "Read Data Stream", the system will display data stream items.

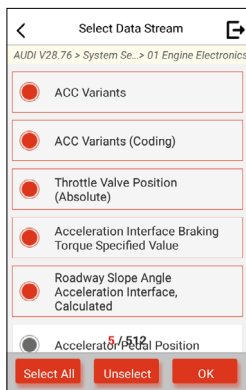

Fig. 5-9

On-Screen Buttons:

Select All: Tap it to select all items of the current page. To select certain data stream item, just check the box before the item name.

Unselect: Tap it to deselect all data stream items.

OK: Tap it to confirm and jump to the next step.

After selecting the desired items, tap "OK" to enter the data stream reading page.

Name	Value	
Acceleration, Raw Value		
Acc Grv SWORD	0.01 g	
Vehicle Inclination Acceleration Angle, Raw Value		
Acc SWORD	0.001 m/s ²	
Status, Incline Angle	(1 / 3)	

Fig. 5-10

Notes:

1. If the value of the data stream item is out of the range of the standard (reference) value, the whole line will display in red. If it complies with the reference value, it displays in blue (normal mode).
2. The indicator 1/X shown on the bottom of the screen stands for the current page / total page number. Swipe the screen from the right / left to advance /return to the next / previous page.

There are 3 types of display modes available for data viewing, allowing you to view various types of parameters in the most suitable way.

- Value – this is the default mode which displays the parameters in texts and shows in list format.
- Graph – displays the parameters in waveform graphs.
- Combine – this option is mostly used in graph merge status for data comparison. In this case, different items are marked in different colors.

On-Screen Buttons:

Tap it to view the waveform graph of the current data stream item.

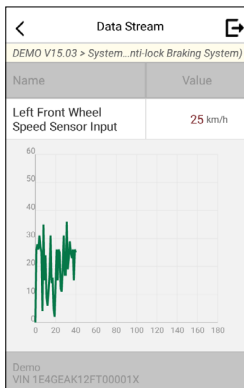

Fig. 5-11

Combine: Tap it, a pull-down list of the data stream items appears on the screen. Select the necessary items (Max. 4 items can be selected at the same time) and the screen will display the waveforms corresponding to these items immediately.

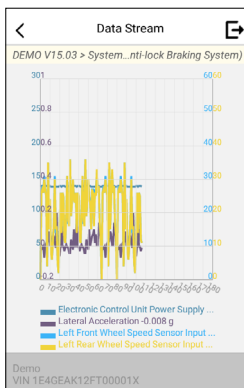

Fig. 5-12

Report: Tap to save the current data as a diagnostic report. All diagnostic reports can be accessed from **Settings -> Data -> Diagnostic Report**. The tool logs the Date of Report (the date and time at which the report was created) and assigns a unique Report #.

Record: Tap to record and save Live Data. Recorded Live Data can serve as

valuable information to help you in troubleshooting and diagnosing vehicle problems. The saved file follows the naming rule: It begins with vehicle type, and then the record starting time and ends with .x431 (To differentiate between files, please configure the accurate system time). All diagnostic records can be viewed by tapping **Settings -> Data -> Diagnostic Record**.

5.3 OBDII Diagnosis

This option presents a quick way to check for DTCs, isolate the cause of the illuminated Malfunction Indicator Lamp (MIL), check monitor status prior to emissions certification testing, verify repairs, and perform a number of other services that are emission-related.

On the Job menu, press [OBD II] to enter system, the screen will automatically navigate to the Monitor status screen.

Tap [OK], the following function list appears.

1. Read Codes

This option is used to identify which section of the emission control system has malfunctioned.

2. Erase Codes

After reading the retrieved codes from the vehicle and certain repairs have been carried out, you can use this function to erase the codes from the vehicle. Before performing this function, please be sure the vehicle's ignition key is in the ON position with the engine off.



Notes:

- Before performing this function, make sure to retrieve and record the trouble codes.
- After clearing, you should retrieve trouble codes once more or turn ignition on and retrieve codes again. If there are still some trouble codes in the system, please troubleshoot the code using a factory diagnosis guide, then clear the code and recheck.

3. I/M Readiness

An important part of a vehicle's OBD II system is the Readiness Monitors, which are indicators used to find out if all of the emissions components have been evaluated by the OBD II system. They are running periodic tests on specific systems and components to ensure that they are performing within allowable limits.

Currently, there are eleven OBD II Readiness Monitors (or I/M Monitors) defined

by the U.S. Environmental Protection Agency (EPA). Not all monitors are supported in every vehicles and the exact number of monitors in any vehicle depends on the motor vehicle manufacturer's emissions control strategy.

Continuous Monitors -- Some of the vehicle components or systems are continuously tested by the vehicle's OBD II system, while others are tested only under specific vehicle operating conditions. The continuously monitored components listed below are always ready:

1. Misfire
2. Fuel System
3. Comprehensive Components (CCM)

Once the vehicle is running, the OBD II system is continuously checking the above components, monitoring key engine sensors, watching for engine misfire, and monitoring fuel demands.

Non-Continuous Monitors -- Unlike the continuous monitors, many emissions and engine system components require the vehicle to be operated under specific conditions before the monitor is ready. These monitors are termed non-continuous monitors and are listed below:

- 1) EGR System
- 2) O2 Sensors
- 3) Catalyst
- 4) Evaporative System
- 5) O2 Sensor Heater
- 6) Secondary air Injection
- 7) Heated Catalyst
- 8) A/C system

I/M refers to Inspection and Maintenance that is legislated by the Government to meet federal clean-air standards. I/M Readiness indicates whether or not the various emissions-related systems on the vehicle are operating properly and are ready for Inspection and Maintenance testing.

The purpose of the I/M Readiness Monitor Status is to indicate which of the vehicle's Monitors have run and completed their diagnosis and testing, and which ones have not yet run and completed testing and diagnosis of their designated sections of the vehicle's emissions system.

The I/M Readiness Monitor Status function also can be used (after repair of a fault has been performed) to confirm that the repair has been performed correctly, and / or to check for Monitor Run Status.

This function can also be done by tapping [I/M Readiness] directly on the Job Menu.

4. Data Stream

This option retrieves and displays live data and parameters from the vehicle's ECU.

5. View Freeze Frame

When an emission-related fault occurs, certain vehicle conditions are recorded by the on-board computer. This information is referred to as freeze frame data. Freeze Data is a snapshot of the operating conditions at the time of an emission-related fault.



Note: If DTCs were erased, Freeze Data may not be stored in vehicle memory depending on vehicle.

6. O2 sensor test

The results of O2 sensor test are not live values but instead the results of the ECU's last O2 sensor test. For live O2 sensor readings, refer to any of the live sensor screens such as Graph Screen.

Not all test values are applicable to all vehicles. Therefore, the list generated will vary depending on vehicle. In addition, not all vehicles support the Oxygen Sensors screen.

7. On-board monitor test

This function can be utilized to read the results of on-board diagnostic monitoring tests for specific components / systems.

8. EVAP System Test

The EVAP test function lets you initiate a leak test for the vehicle's EVAP system. The tool does not perform the leak test, but signals to vehicle's on-board computer to initiate the test. Before using the system test function, refer to the vehicle's service repair manual to determine the procedures necessary to stop the test.

9. Vehicle Info

This option displays the vehicle information, such as VIN (Vehicle Identification Number), CID (Calibration ID) and CVN (Calibration Verification Number).

5.4 History

Generally once a vehicle diagnosis is performed, the tool will record the every

details of diagnostic session. The History function provides direct access to the previously tested vehicles and users can resume from the last operation, without the necessity of starting from scratch.

Tap “History” on the Diagnose main menu screen, all diagnostic records will be listed on the screen in date sequence.

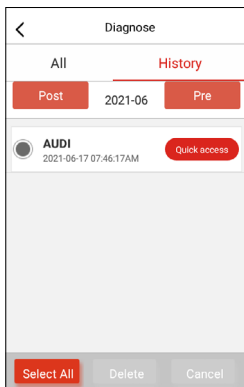

Fig. 5-13

- Tap certain vehicle model to view the details of the last diagnostic report.
- To delete certain diagnostic history, select it and then tap “Delete”. To delete all historical records, tap “Select All” and then tap “Delete”.
- Tap “Quick access” to directly navigate to the function selection page of last diagnostic operation. Choose the desired option to proceed.

5.5 Reset (Special Functions)

In addition to powerful diagnostic function, Creader Elite 202/Creader Elite 205 also features different kinds of reset functions.

5.5.1 Download reset software

The available reset procedures depends on your opt.

For Creader Elite 200, no special function software packages are preset for download and use. Go to “Mall” on the Job menu to purchase it if necessary.

For Creader Elite 202, total two special function software packages are available for download and use free of charge.

For Creader Elite 205, total five special function software packages are available for download and use free of charge.

To subscribe other special function software for Creader Elite 202/Creader Elite 205, go to “Mail” on the Job menu to purchase it.

For initial use, user needs to select and download the desired reset software.

Tap “Reset”, all available reset software will be listed on the screen. Select the desired reset software and tap “OK”, the system will navigate to the update center to download.

5.5.2 How to perform reset procedures?

There are two methods to reset service lamp: Manual Reset or Auto Reset. Auto Reset follows the principle of sending command from the tool to vehicle's ECU to do resetting. While using Manual Reset, users just follow the on-screen instructions to select appropriate execution options, enter correct data or values, and perform necessary actions, the system will guide you through the complete performance for various service operations.

Follow the flowchart shown as below to perform resetting.

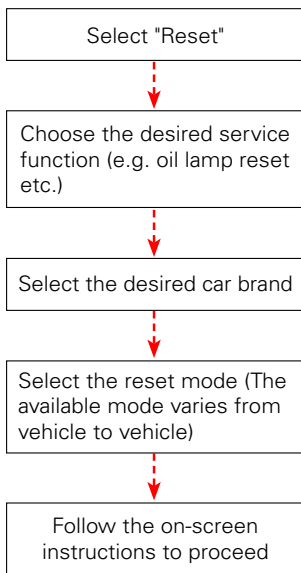

6. Upgrade

This function allows you to update the diagnostic app and software. All software is updated periodically.

It is recommended to check regularly for updates and install the latest software version for the best service, functions and experience.

 Note: Make sure the Wi-Fi connection is strong and stable while updating.

Tap “Upgrade” on the Job menu to enter the update center.

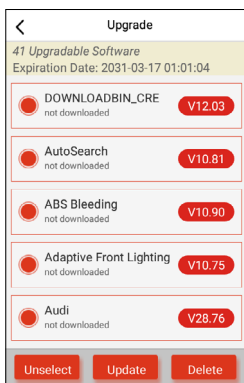

Fig. 6-1

By default, all diagnostic software is selected.

To deselect certain software, tap “Unselect”, and then check the box next to vehicle model.

Tap “Update” to start downloading. It may take several minutes to finish, please be patient.

Once download is finished, the software packages will be installed automatically.

7. Mall

This function allows you to subscribe other vehicle diagnostic software and reset software that are not pre-installed on the tool.

All diagnostic software in the mall covers full systems and full functions (excluding online programming and coding etc). Different vehicle software is tagged with different price.

Tap "Mall" to open the online software mall. Select the target software and follow the on-screen instructions to finish the transaction.



Note: The software service belongs to the virtual goods. It becomes immediately effective from the date of the successful transaction and it does not accept the refund. When making payment, please double check the order information.

The subscribed software can be free to use for one year. After it expires, it will become disabled and user needs to renew the subscription to activate it.

8. Settings

8.1 Units of measurement

It is designed to set the measurement unit. Metric System and English System are available.

8.2 Automatic detection on connect

This option enables you to determine whether to start an automatic VIN detection once the tool is properly connected to the vehicle's DLC.

8.3 Brightness

This item allows you to set the screen brightness.



Note: Reducing the brightness of the screen is helpful to conserve the power of the tool.

8.4 Sound

This option lets you adjust the volume and other sound settings.

8.5 Network



Note: Once WLAN is set as ON, the tool will consume more power. While it keeps unused, please set it off to save power. While WLAN keeps unused, please turn it off to conserve battery power.

The tool has built-in WLAN module that can be used to get online. Once you're online, you can register your tool and update diagnostic software & APK.

Slide the switch to ON, the system starts searching for all available wireless LANs. Choose the desired WLAN access point / network to connect.

8.6 Time Zone

This option allows you to set the time zone.

8.7 Language

The tool supports multiple languages. You can use this option to change the system language to the target language.

8.8 Workshop information

This option allows you to add a personalized tag on the diagnostic reports.

 Note: After you configured it, the system will append it on the report every time a report is successfully generated.

8.9 Recovery

Use this item to reset this tool to the default factory setting.

 Warning: Resetting may cause data loss. Before doing so, please be careful to perform this operation.

8.10 Clean Up

This option allows user to clear some cache files and free up some storage space. After clean up, the tool will reboot automatically.

8.11 Screen Capture

When set as ON, a floating screenshot icon will appear on the screen. Tap it to capture the current screen. All screenshots are saved under **Settings -> Data -> Image**.

8.12 About

This option displays the hardware configuration information of the tool and license agreement.

8.13 Data

8.13.1 Diagnostic Record

If a user records the running parameters or waveform graphs while reading data stream, it will be saved as diagnostic records and appear under this tab.

Tap “Diagnostic Record” to enter and select the desired data stream items, and tap “OK” to jump to the playback page.

On-Screen Buttons:

Graph – displays the parameters in waveform graphs.

Combine – this option is mostly used in graph merge status for data comparison. In this case, different items are marked in different colors.

Value – this is the default mode which displays the parameters in texts and shows in list format.

Frame Playback – plays back the recorded data stream items frame by frame. Once it is in frame playback mode, this button changes into “Auto Playback”.

8.13.2 Diagnostic Report

This module stores all diagnostic reports generated in process of vehicle diagnosis.

All the diagnostic reports are sorted by Date and Make. If there are too many reports stored, tap  (Search) to filter and quickly locate it.

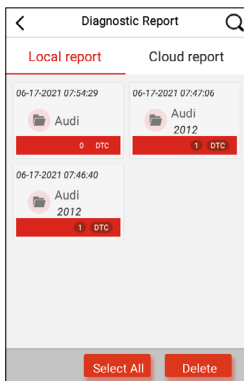

Fig. 7-1

- To select a certain report, just check the box at the right lower corner of the report. To select all reports, tap “Select All”. To deselect all, tap “Unselect”.
- Tap it to view its details.
- Select the desired report and then tap “Delete” to delete it.

8.13.3 DTC Library

This option enables you to retrieve the detailed description of certain DTC from the local DTC database.

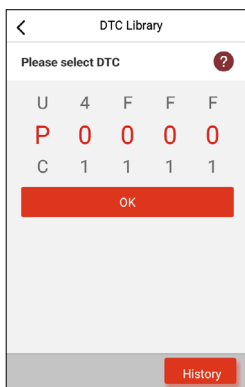

Fig. 7-2

Swipe the screen upwards / downwards to alter the value, then press [OK] button, the screen will display definition of the DTC.

8.13.4 DLC (Data Link Connector) Location

This option helps you to find the location of the vehicle's DLC.

8.13.5 Image

This option allows you to view and manage all screenshots.

8.13.6 Feedback

This item allows you to feedback your diagnostic problems to us for analysis and troubleshooting.

Tap "Feedback", the following 3 options will be displayed on the screen.

A. Feedback

Tap a tested vehicle model to enter the feedback screen.

- 1) Tap "Choose File" to open the target folder and choose the desired diagnostic logs.
- 2) Choose the failure type and fill in the detailed failure description in the blank text box and telephone or email address. After inputting, tap "Submit Result" to send it to us.

B. History

Tap it to view all diagnostic feedback records. Different process states are

marked with different colors.

C. Offline list

Tap it to display all diagnostic feedback logs which have not been submitted successfully due to network failure. Once the tool gets a stable network signal, it will be uploaded to the remote server automatically.

8.13.7 Firmware Fix

Use this item to upgrade and fix diagnostic firmware. During fixing, please do not cut power or switch to other interfaces.

8.13.8 User Manual

The user manual is integrated on the tool for your easier check and reference.

9. FAQ

Here we list some frequently asked questions and answers related to this tool.

1 System halts when reading data stream. What is the reason?

It may be caused by a slackened connector. Please turn this tool off, firmly connect the connector, and switch it on again.

2 Screen of the tool flashes at engine ignition start.

Caused by electromagnetic disturbing, and this is normal phenomenon.

3 There is no response when communicating with on-board computer.

Please confirm the proper voltage of power supply and check if the throttle has been closed, the transmission is in the neutral position, and the water is in proper temperature.

4 What to do if the system fails to start auto VIN detection?

Please check the following possible reasons:

- Whether the tool is properly connected to the vehicle's DLC port.
- Whether the "Automatic detection on Connect" switch is OFF. If yes, slide it to ON.

5 Why are there so many fault codes?

Usually, it's caused by poor connection or fault circuit grounding.

6 How to upgrade the system?

1. Switch the tool on and ensure a stable internet connection.
2. Tap "Settings" on the Job Menu, select "About" -> "Version", and tap "Detect the System Version" to enter the system upgrading page.
3. Follow the on-screen instructions step by step to finish the process. It may take several minutes depending on the internet speed, please be patient. After upgrade is successfully finished, the tool will automatically restart and enters the Job menu.

If you have any questions on the operation of the unit, please contact customer service number: +86-755-84557891.

Statement:

We reserve the rights to make any change to product designs and specifications without notice. The actual object may differ a little from the descriptions in the manual in physical appearance, color and configuration. We have tried our best to make the descriptions and illustrations in the manual as accurate as possible, and defects are inevitable, if you have any question, please contact local dealer or after-sale service center, we shall not bear any responsibility arising from misunderstandings.

The device has been evaluated to meet general RF exposure requirement. The SAR limit of USA (FCC) is 1.6 W/kg averaged over one gram of tissue. Device types Professional Diagnostic Tool with model Creader Elite 200,

Creader Elite xyy ("x=0-9 or A-Z, "yy" =00-99 or blank), Millennium X,

Creader EURxx("xx"=01-99), Creader Elite xyzabcdefg("xyzabcdefg"=Any

letter) (FCC ID: XUJCRE305) has also been tested against this SAR limit.

The highest reported SAR values for body is 1.13W/kg. This device was tested for typical body operations with the back of the handset kept 0mm from the body. The use of accessories that do not satisfy these requirements may not comply with FCC RF exposure requirements, and should be avoided.