

# FCC Test Report

Product Name : WiFi HD Baby Cam

Model No. : TV-IP745SIC

FCC ID. : XU8TVIP745SIC

Applicant : TRENDnet, INC

Address : 20675 Manhattan Place, Torrance, CA 90501 U.S.A.

Date of Receipt : 2014/07/25

Issued Date : 2014/09/10

Report No. : 1470566R-RFUSP26V00

Report Version : V1.0



The test results relate only to the samples tested.

The test report shall not be reproduced except in full without the written approval of QuieTek Corporation.

## Test Report Certification

Issued Date : 2014/09/10

Report No. : 1470566R-RFUSP26V00

# Quietek

Product Name : WiFi HD Baby Cam  
Applicant : TRENDnet, INC  
Address : 20675 Manhattan Place, Torrance, CA 90501 U.S.A.  
Model No. : TV-IP745SIC  
FCC ID. : XU8TVIP745SIC  
EUT Test Voltage : AC 100-240V, 50/60Hz  
Trade Name : TRENDnet  
Applicable Standard : FCC CFR Title 47 Part 15 Subpart C Section 15.247: 2013  
ANSI C63.4: 2009  
Test Result : Complied

The test results relate only to the samples tested.

The test report shall not be reproduced except in full without the written approval of Quietek Corporation.

Documented By : Fonbo Fang  
( Fonbo Fang / Engineering Adm. Assistant )

Reviewed By : JuBo Shen  
( JuBo Shen / Engineer)

Approved By : Roy Wang  
( Roy Wang / Director )

## Laboratory Information

We, **Quietek Corporation**, are an independent RF consultancy that was established the whole facility in our laboratories. The test facility has been accredited/accepted (audited or listed) by the following related bodies in compliance with ISO 17025 specified testing scopes:

<b>Taiwan R.O.C.</b>	<b>:</b>	<b>TAF, Accreditation Number: 1313</b> <b>NCC, Certificate No : NCC-RCB-07</b>
<b>USA</b>	<b>:</b>	<b>FCC, Registration Number: 365520</b>
<b>Canada</b>	<b>:</b>	<b>IC, Submission No: 150981</b>

The related certificate for our laboratories about the test site and management system can be downloaded from Quietek Corporation's Web Site:<http://www.quietek.com/tw/ctg/cts/accreditations.htm>

The address and introduction of Quietek Corporation's laboratories can be founded in our Web site : <http://www.quietek.com/>

If you have any comments, Please don't hesitate to contact us. Our contact information is as below:

### **HsinChu Testing Laboratory:**

No.75-2, 3rd Lin, Wangye Keng, Yonghxing Tsuen, Qionglin Shiang, Hsinchu County 307, Taiwan, R.O.C.  
 TEL:+886-3-592-8858 / FAX:+886-3-592-8859                      E-Mail : [service@quietek.com](mailto:service@quietek.com)

### **Linkou Testing Laboratory:**

No.5-22, Ruishukeng, Linkou Dist., New Taipei City 24451, Taiwan, R.O.C.  
 TEL : 886-2-8601-3788 / FAX : 886-2-8601-3789                      E-Mail : [service@quietek.com](mailto:service@quietek.com)

## TABLE OF CONTENTS

Description	Page
1. General Information.....	6
1.1. EUT Description .....	6
1.2. Test Mode .....	10
1.3. Tested System Details .....	11
1.4. Configuration of tested System .....	11
1.5. EUT Exercise Software .....	12
1.6. Test Facility.....	13
2. Conducted Emission .....	14
2.1. Test Equipment.....	14
2.2. Test Setup .....	14
2.3. Limits .....	15
2.4. Test Procedure .....	15
2.5. Test Specification.....	15
2.6. Uncertainty .....	15
2.7. Test Result.....	16
2.8. Test Photo .....	18
3. Peak Power Output .....	19
3.1. Test Equipment.....	19
3.2. Test Setup .....	19
3.3. Test procedures .....	19
3.4. Limits .....	19
3.5. Test Specification.....	19
3.6. Uncertainty .....	19
3.7. Test Result.....	20
4. Radiated Emission .....	32
4.1. Test Equipment.....	32
4.2. Test Setup .....	32
4.3. Limits .....	33
4.4. Test Procedure .....	33
4.5. Test Specification.....	33
4.6. Uncertainty .....	33
4.7. Test Result.....	34
4.8. Test Photo .....	59
5. RF antenna conducted test .....	61
5.1. Test Equipment.....	61
5.2. Test Setup .....	61
5.3. Limits .....	62
5.4. Test Procedure .....	62

---

5.5.	Test Specification.....	62
5.6.	Uncertainty .....	62
5.7.	Test Result.....	63
6.	Radiated Emission Band Edge.....	90
6.1.	Test Equipment.....	90
6.2.	Test Setup .....	90
6.3.	Limits .....	91
6.4.	Test Procedure .....	91
6.5.	Test Specification.....	91
6.6.	Uncertainty .....	91
6.7.	Test Result.....	92
7.	DTS Bandwidth .....	116
7.1.	Test Equipment.....	116
7.2.	Test Setup .....	116
7.3.	Test Procedures .....	116
7.4.	Limits .....	116
7.5.	Test Specification.....	116
7.6.	Uncertainty .....	116
7.7.	Test Result.....	117
8.	Occupied Bandwidth .....	126
8.1.	Test Equipment.....	126
8.2.	Test Setup .....	126
8.3.	Test Procedures .....	126
8.4.	Limits .....	126
8.5.	Test Specification.....	126
8.6.	Uncertainty .....	126
8.7.	Test Result.....	127
9.	Power Density .....	136
9.1.	Test Equipment.....	136
9.2.	Test Setup .....	136
9.3.	Limits .....	136
9.4.	Test Procedures .....	136
9.5.	Test Specification.....	136
9.6.	Uncertainty .....	137
9.7.	Test Result.....	138
	Attachement.....	147
	EUT Photograph.....	147

## 1. General Information

### 1.1. EUT Description

Product Name	WiFi HD Baby Cam
Trade Name	TRENDnet
Model No.	TV-IP745SIC
Frequency Range/Channel Number -IEEE 802.11b/g & IEEE 802.11n (20MHz)_2.4GHz	2412~2462MHz / 11 Channels
Type of Modulation (IEEE 802.11b)	Direct Sequence Spread Spectrum (DSSS)
Type of Modulation (IEEE 802.11g/n)	Orthogonal Frequency Division Multiplexing (OFDM)
Data Speed (IEEE 802.11b)	1Mbps, 2Mbps, 5.5Mbps, 11Mbps
Data Speed (IEEE 802.11g)	6Mbps,9Mbps,12Mbps,18Mbps,24Mbps,36Mbps,48Mbps,54Mbps
Data Speed (IEEE 802.11n)	Support a subset of the combination of GI, MCS 0~MCS 7 and bandwidth defined in HT20
Antenna Gain	2.93 dBi
Antenna Type	PCB Antenna(1TX, 1RX)

Component	
Power Adapter	AMIGO, AMS1-0501200FU I/P: 100-240~50/60Hz 0.2A O/P: 5V $\equiv$ 1.2A Cable Out: Non-Shielded, 3.0m

ANT-TX / RX & Bandwidth

ANT-TX / RX	TX		RX	
	20MHz	40MHz	20MHz	40MHz
IEEE802.11b	✓		✓	
IEEE802.11g	✓		✓	
IEEE802.11n	✓		✓	

**(1TX /1RX)**

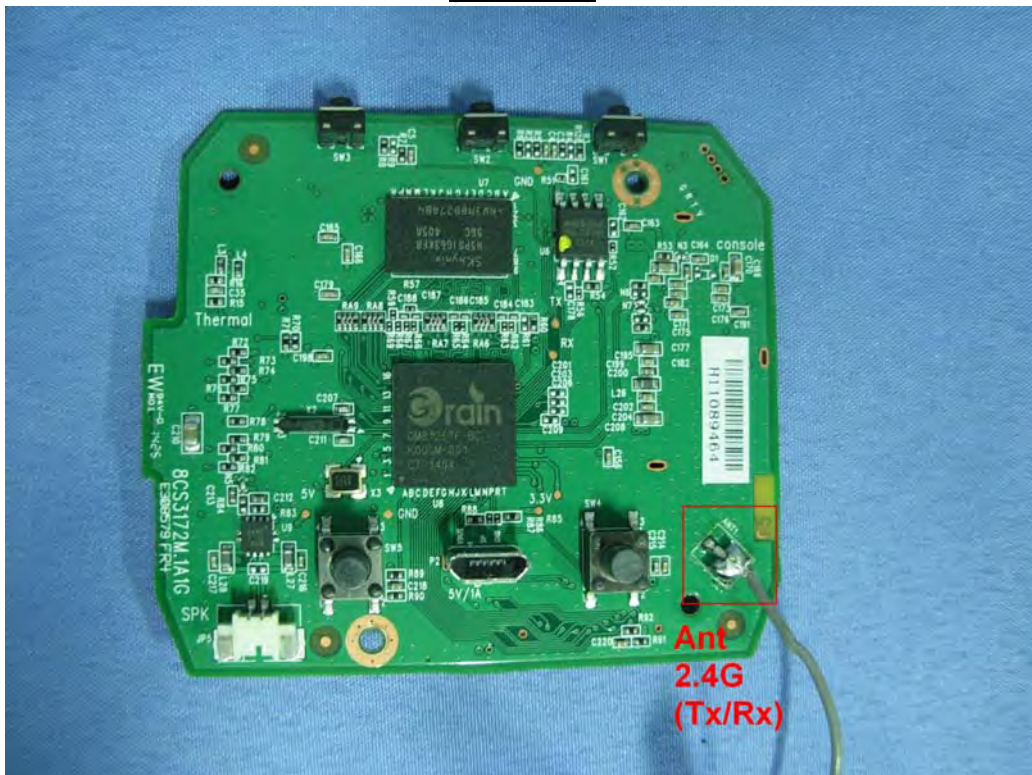

**IEEE 802.11n**

MCS Index	Modulation	R	N <sub>BPSCS</sub>	N <sub>CBPS</sub>		N <sub>DBPS</sub>		Data Rate(Mb/s)			
				20MHz	40MHz	20MHz	40MHz	800ns GI		400ns GI	
								20MHz	40MHz	20MHz	40MHz
0	BPSK	1/2	1	52	108	26	54	6.5	13.5	7.2	15.0
1	QPSK	1/2	2	104	216	52	108	13.0	27.0	14.4	30.0
2	QPSK	3/4	2	104	216	78	162	19.5	40.5	21.7	45.0
3	16-QAM	1/2	4	208	432	104	216	26.0	54.0	28.9	60.0
4	16-QAM	3/4	4	208	432	156	324	39.0	81.0	43.3	90.0
5	64-QAM	2/3	6	312	648	208	432	52.0	108.0	57.8	120.0
6	64-QAM	3/4	6	312	648	234	486	58.5	121.5	65.0	135.0
7	64-QAM	5/6	6	312	648	260	540	65.0	135.0	72.2	150.0

Note 1: Support of 400ns GI is optional on transmit and receive.

Table 1 – MCS parameters for TX Antenna number = 1

Symbol	Explanation
R	Code rate
N <sub>BPSC</sub>	Number of coded bits per single carrier
N <sub>CBPS</sub>	Number of coded bits per symbol
N <sub>DBPS</sub>	Number of data bits per symbol
GI	guard interval



## IEEE 802.11b/g &amp; IEEE 802.11n (20MHz)

Working Frequency of Each Channel							
Channel	Frequency	Channel	Frequency	Channel	Frequency	Channel	Frequency
001	2412 MHz	002	2417 MHz	003	2422 MHz	004	2427 MHz
005	2432 MHz	006	2437 MHz	007	2442 MHz	008	2447 MHz
009	2452 MHz	010	2457 MHz	011	2462 MHz		

## Note:

1. This device is the WiFi HD Baby Cam including 2.4GHz b/g/n (1x1) transmitting and receiving function.
2. These test results on a sample of the device are for the purpose of demonstrating Compliance with Part 15 Subpart C Paragraph 15.247.
3. Regards to the frequency band operation; the lowest , middle and highest frequency of channel were selected to perform the test, and then shown on this report.
4. This device is a composite device in accordance with Part 15 regulations. The receiving function receiving was tested and its test report number is 1470566R-RFUSP01V00 under Declaration of Conformity.

**1.2. Test Mode**

Quietek has verified the construction and function in typical operation. The preliminary tests were performed in different data rate, and to find the worst condition, which was shown in this test report. The following table is the final test mode.

TX	Mode 1: Transmit
----	------------------

Test Items	Modulation	Channel	Antenna	Result
Conducted Emission	11n(20MHz)	6	0	Complies
Peak Power Output	b/g	1/ 6/ 11	0	Complies
	11n(20MHz)	1/ 6/ 11	0	Complies
Radiated Emission	b/g	1/ 6/ 11	0	Complies
	11n(20MHz)	1/ 6/ 11	0	Complies
RF antenna conducted test	b/g	1/ 6/ 11	0	Complies
	11n(20MHz)	1/ 6/ 11	0	Complies
DTS Bandwidth	b/g	1/ 6/ 11	0	Complies
	11n(20MHz)	1/ 6/ 11	0	Complies
Radiated Emission Band Edge	b/g	1/ 6/ 11	0	Complies
	11n(20MHz)	1/ 6/ 11	0	Complies
Occupied Bandwidth	b/g	1/ 6/ 11	0	Complies
	11n(20MHz)	1/ 6/ 11	0	Complies
Power Density	b/g	1/ 6/ 11	0	Complies
	11n(20MHz)	1/ 6/ 11	0	Complies

### 1.3. Tested System Details

The types for all equipments, plus descriptions of all cables used in the tested system (including inserted cards) are:

Product	Manufacturer	Model No.	Serial No.	Power Cord
1 Fixture	Alpha	N/A	N/A	--
2 Notebook PC	ACER	MS2296	LUSCV0213911503 32C2000	Non-Shielded, 2.5m one ferrite core bonded

### 1.4. Configuration of tested System

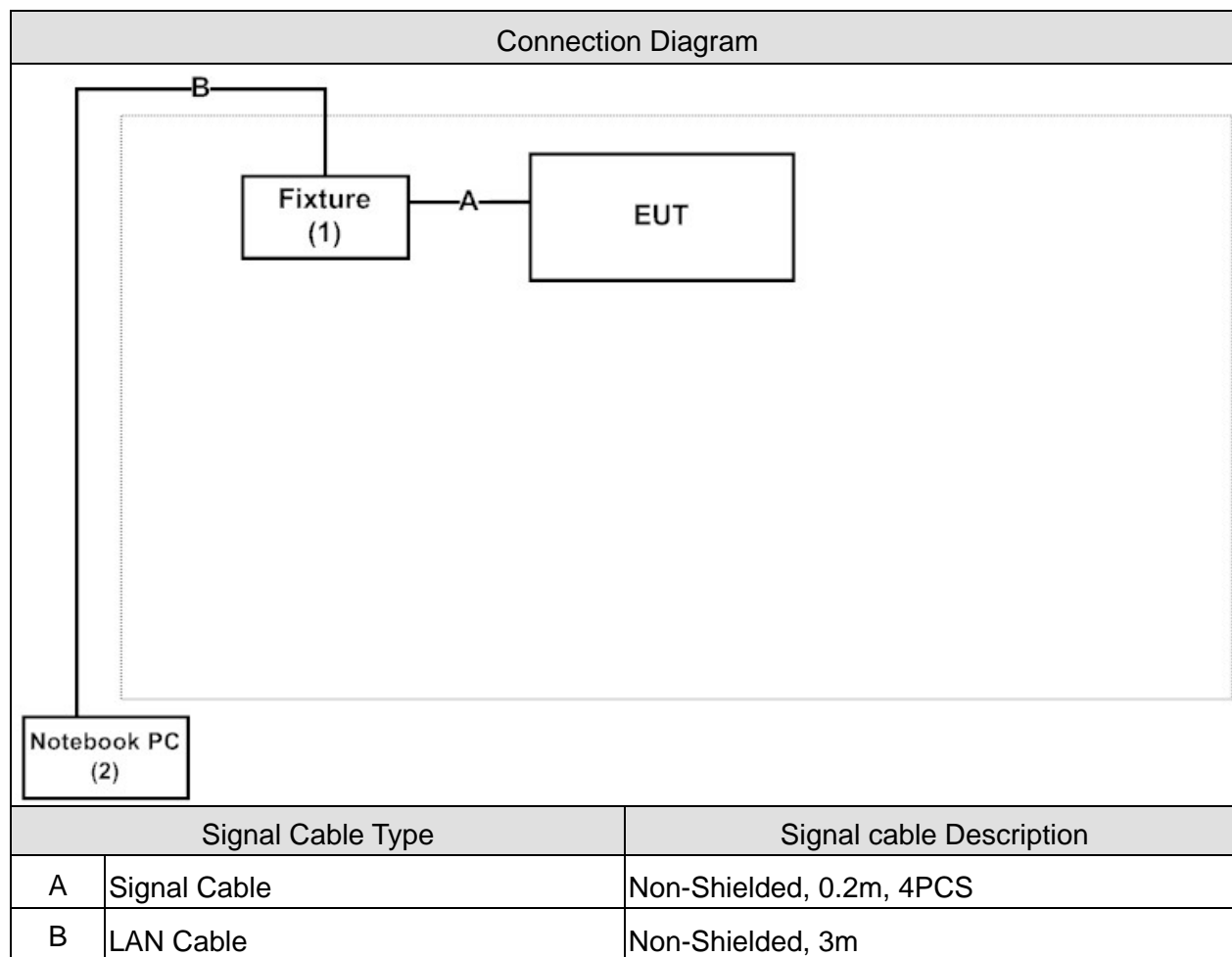

**1.5. EUT Exercise Software**

1	Test system is in accord with EUT user manual (refer to 1.4 configuration of tested system)
2	Execute the Telnet command on the Notebook.
3	Configure the test mode, the test channel, and the data rate.
4	Make the EUT to start the continuous transmitting.
5	Verify that the EUT works properly.

## 1.6. Test Facility

Ambient conditions in the laboratory:

Items	Test Item	Required (IEC 68-1)	Actual
Temperature (°C)	FCC PART 15 C 15.207 Conducted Emission	15 - 35	20
Humidity (%RH)		25 - 75	50
Barometric pressure (mbar)		860 - 1060	950-1000
Temperature (°C)	FCC PART 15 C 15.247 Peak Power Output	15 - 35	25
Humidity (%RH)		25 - 75	45
Barometric pressure (mbar)		860 - 1060	950-1000
Temperature (°C)	FCC PART 15 C 15.247 Radiated Emission	15 - 35	20
Humidity (%RH)		25 - 75	50
Barometric pressure (mbar)		860 - 1060	950-1000
Temperature (°C)	FCC PART 15 C 15.247 RF antenna conducted test	15 - 35	25
Humidity (%RH)		25 - 75	45
Barometric pressure (mbar)		860 - 1060	950-1000
Temperature (°C)	FCC PART 15 C 15.247 Band Edge	15 - 35	20
Humidity (%RH)		25 - 75	50
Barometric pressure (mbar)		860 - 1060	950-1000
Temperature (°C)	FCC PART 15 C 15.247 DTS Bandwidth	15 - 35	25
Humidity (%RH)		25 - 75	45
Barometric pressure (mbar)		860 - 1060	950-1000
Temperature (°C)	FCC PART 15 C 15.247 Occupied Bandwidth	15 - 35	25
Humidity (%RH)		25 - 75	45
Barometric pressure (mbar)		860 - 1060	950-1000
Temperature (°C)	FCC PART 15 C 15.247 Power Density	15 - 35	25
Humidity (%RH)		25 - 75	45
Barometric pressure (mbar)		860 - 1060	950-1000

**2. Conducted Emission**

**2.1. Test Equipment**

The following test equipments are used during the test:

Conducted Emission / SR2

Instrument	Manufacturer	Model No.	Serial No	Next Cal. Date
Artificial Mains Network	R&S	ENV4200	848411/010	2015/02/09
LISN	R&S	ENV216	100092	2015/08/24
Test Receiver	R&S	ESCS 30	825442/014	2015/07/13
Coaxial Cable	Harbour	RG-400	SR2	2015/08/14
Quietek EMI system	Quietek	Version 2.2	SR2	N/A

Note: 1. All equipments that need to calibrate are with calibration period of 1 year.

**2.2. Test Setup**

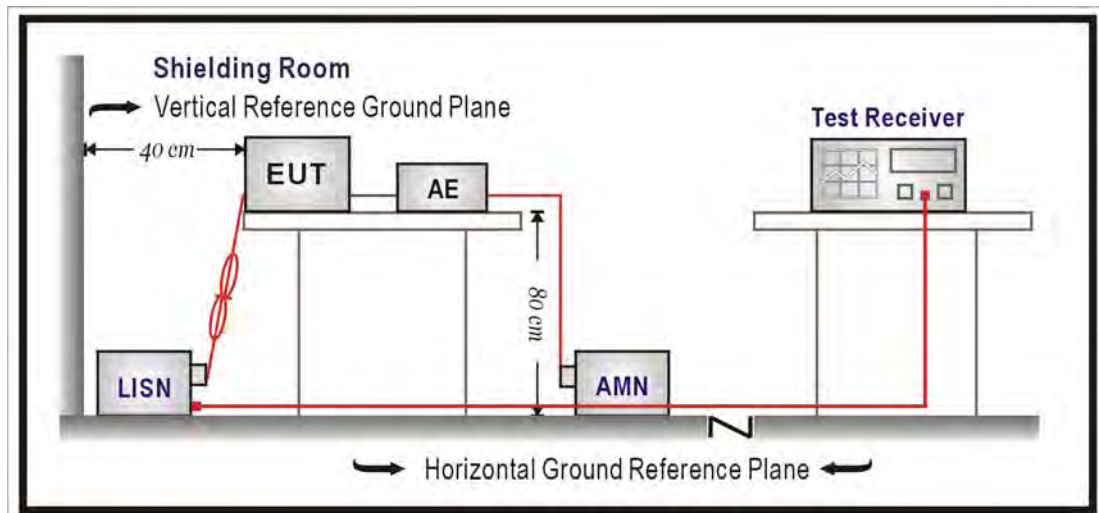

**2.3. Limits**

<b>FCC Part 15 Subpart C Paragraph 15.207 Limits (dBuV)</b>		
Frequency MHz	QP	AV
0.15 - 0.50	66-56	56-46
0.50 - 5.0	56	46
5.0 - 30	60	50

Remarks: In the above table, the tighter limit applies at the band edges.

**2.4. Test Procedure**

The EUT was setup according to ANSI C63.4: 2009 and tested according to DTS test procedure of KDB558074 for compliance to FCC 47CFR 15.247 requirements.

The EUT was placed on a platform of nominal size, 1 m by 1.5 m, raised 80 cm above the conducting ground plane. The vertical conducting plane was located 40 cm to the rear of the EUT. All other surfaces of EUT were at least 80 cm from any other grounded conducting surface. The EUT and simulators are connected to the main power through a line impedance stabilization network (LISN). The LISN provides a 50 ohm /50uH coupling impedance for the measuring equipment. The peripheral devices are also connected to the main power through a LISN. (Please refer to the block diagram of the test setup and photographs.)

Each current-carrying conductor of the EUT power cord, except the ground (safety) conductor, was individually connected through a LISN to the input power source.

The excess length of the power cord between the EUT and the LISN receptacle were folded back and forth at the center of the lead to form a bundle not exceeding 40 cm in length.

Conducted emissions were investigated over the frequency range from 0.15MHz to 30MHz using a receiver bandwidth of 9 kHz.

**2.5. Test Specification**

According to FCC Part 15 Subpart C Paragraph 15.207: 2013

**2.6. Uncertainty**

The measurement uncertainty is defined as  $\pm 2.26$  dB.

2.7. Test Result

Site : SR2	Time : 2014/08/25 - 20:28
Limit : CISPR_B_00M_QP	Margin : 10
Probe : SR2_LISN(16A)-3_0822 - Line1	Power : AC 120V / 60Hz
EUT : WiFi HD Baby Cam	Note : 802.11n 20MHz_CH06

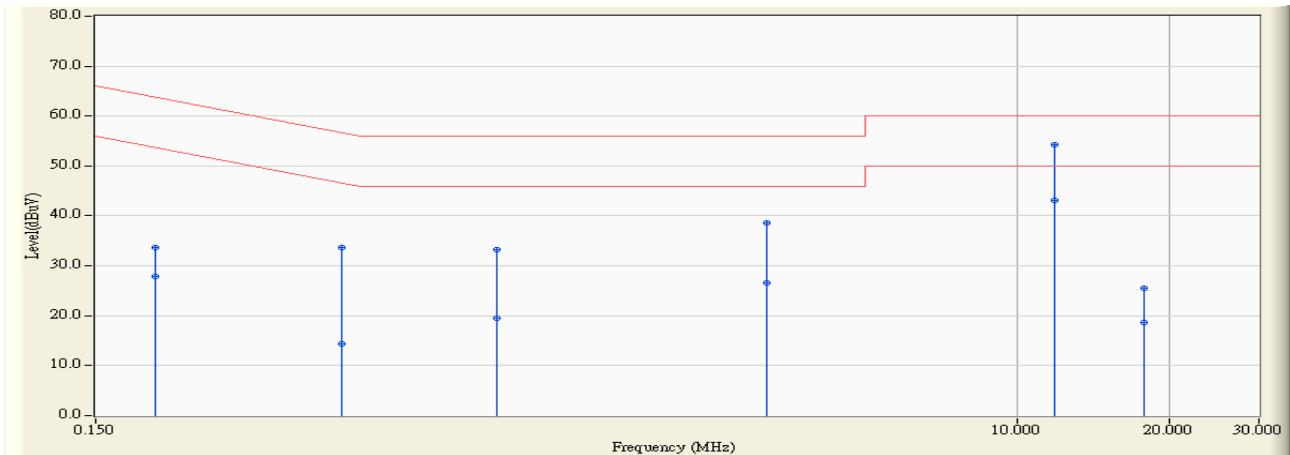

	Frequency (MHz)	Correct Factor (dB)	Reading Level (dBuV)	Measure Level (dBuV)	Margin (dB)	Limit (dBuV)	Detector Type
1	0.197	9.644	23.980	33.624	-30.117	63.741	QUASPEAK
2	0.197	9.644	18.230	27.874	-25.867	53.741	AVERAGE
3	0.459	9.719	24.040	33.759	-22.959	56.718	QUASPEAK
4	0.459	9.719	4.630	14.349	-32.369	46.718	AVERAGE
5	0.931	9.739	23.510	33.249	-22.751	56.000	QUASPEAK
6	0.931	9.739	9.710	19.449	-26.551	46.000	AVERAGE
7	3.193	9.896	28.610	38.506	-17.494	56.000	QUASPEAK
8	3.193	9.896	16.740	26.636	-19.364	46.000	AVERAGE
9	* 11.826	10.157	44.070	54.227	-5.773	60.000	QUASPEAK
10	11.826	10.157	32.870	43.027	-6.973	50.000	AVERAGE
11	17.752	10.130	15.330	25.460	-34.540	60.000	QUASPEAK
12	17.752	10.130	8.530	18.660	-31.340	50.000	AVERAGE

Note:

1. All Reading Levels are Quasi-Peak and average value.
2. " \* ", means this data is the worst emission level.
3. Measurement Level = Reading Level + Correct Factor.



Site : SR2	Time : 2014/08/25 - 20:31
Limit : CISPR_B_00M_QP	Margin : 10
Probe : SR2_LISN(16A)-3_0822 - Line2	Power : AC 120V / 60Hz
EUT : WiFi HD Baby Cam	Note : 802.11n 20MHz_CH06

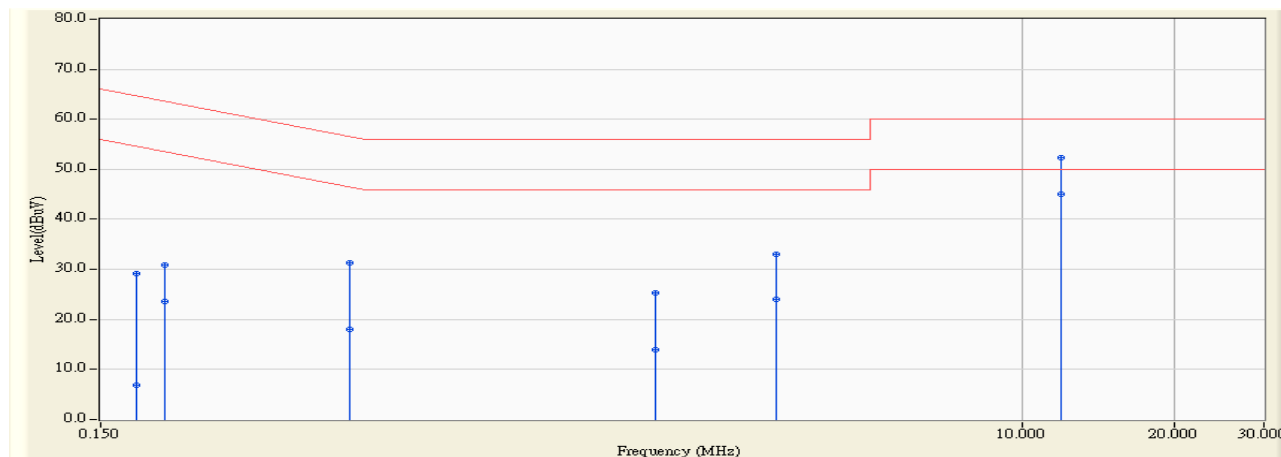

	Frequency (MHz)	Correct Factor (dB)	Reading Level (dBuV)	Measure Level (dBuV)	Margin (dB)	Limit (dBuV)	Detector Type
1	0.177	9.628	19.590	29.218	-35.392	64.609	QUASPEAK
2	0.177	9.628	-2.800	6.828	-47.782	54.609	AVERAGE
3	0.201	9.634	21.190	30.824	-32.754	63.578	QUASPEAK
4	0.201	9.634	13.890	23.524	-30.054	53.578	AVERAGE
5	0.466	9.701	21.530	31.231	-25.346	56.578	QUASPEAK
6	0.466	9.701	8.300	18.001	-28.576	46.578	AVERAGE
7	1.877	9.817	15.590	25.406	-30.594	56.000	QUASPEAK
8	1.877	9.817	4.180	13.996	-32.004	46.000	AVERAGE
9	3.255	9.885	23.250	33.134	-22.866	56.000	QUASPEAK
10	3.255	9.885	14.150	24.034	-21.966	46.000	AVERAGE
11	11.896	10.191	42.050	52.241	-7.759	60.000	QUASPEAK
12	* 11.896	10.191	34.930	45.121	-4.879	50.000	AVERAGE

**Note:**

1. All Reading Levels are Quasi-Peak and average value.
2. " \* ", means this data is the worst emission level.
3. Measurement Level = Reading Level + Correct Factor.

**3. Peak Power Output**

**3.1. Test Equipment**

The following test equipments are used during the test:

Peak Power Output / SR7

Instrument	Manufacturer	Model No.	Serial No	Next Cal. Date
Spectrum Analyzer	Agilent	N9010A-EXA	US47140172	2015/07/14

Note: 1. All equipments that need to calibrate are with calibration period of 1 year.

**3.2. Test Setup**

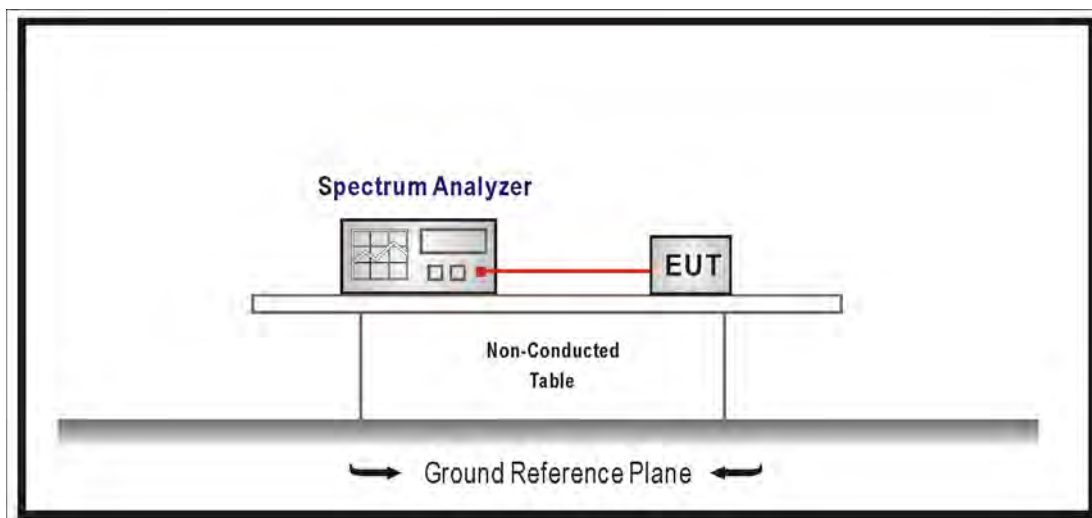

**3.3. Test procedures**

The EUT was tested according to DTS test procedure section 9.1.2 of KDB558074 v03r02 measurement to FCC 47CFR 15.247 requirements.

**3.4. Limits**

The maximum peak power shall be less 1 Watt.

**3.5. Test Specification**

According to FCC Part 15 Subpart C Paragraph 15.247: 2013

**3.6. Uncertainty**

The measurement uncertainty is defined as  $\pm 1.27$  dB.

**3.7. Test Result**

Product	WiFi HD Baby Cam		
Test Item	Peak Power Output		
Test Mode	Mode 1: Transmit		
Date of Test	2014/08/16	Test Site	SR7

IEEE 802.11b, ANT 0				
Channel No.	Frequency (MHz)	Measure Level (dBm)	Limit (dBm)	Result
1	2412	18.65	≤ 30	Pass
6	2437	18.41	≤ 30	Pass
11	2462	18.58	≤ 30	Pass

The worst emission of data rate is 1Mbps.

Peak Power Output (dBm)						
Channel No	Frequency (MHz)	Data Rate (Mbps)				Required Limit
		1	2	5.5	11	
1	2412	18.65	--	--	--	1 Watt=30dBm
6	2437	18.41	18.39	18.35	18.25	1 Watt=30dBm
11	2462	18.58	--	--	--	1 Watt=30dBm

Note: Measure Level =Reading value + cable loss

## Channel 1

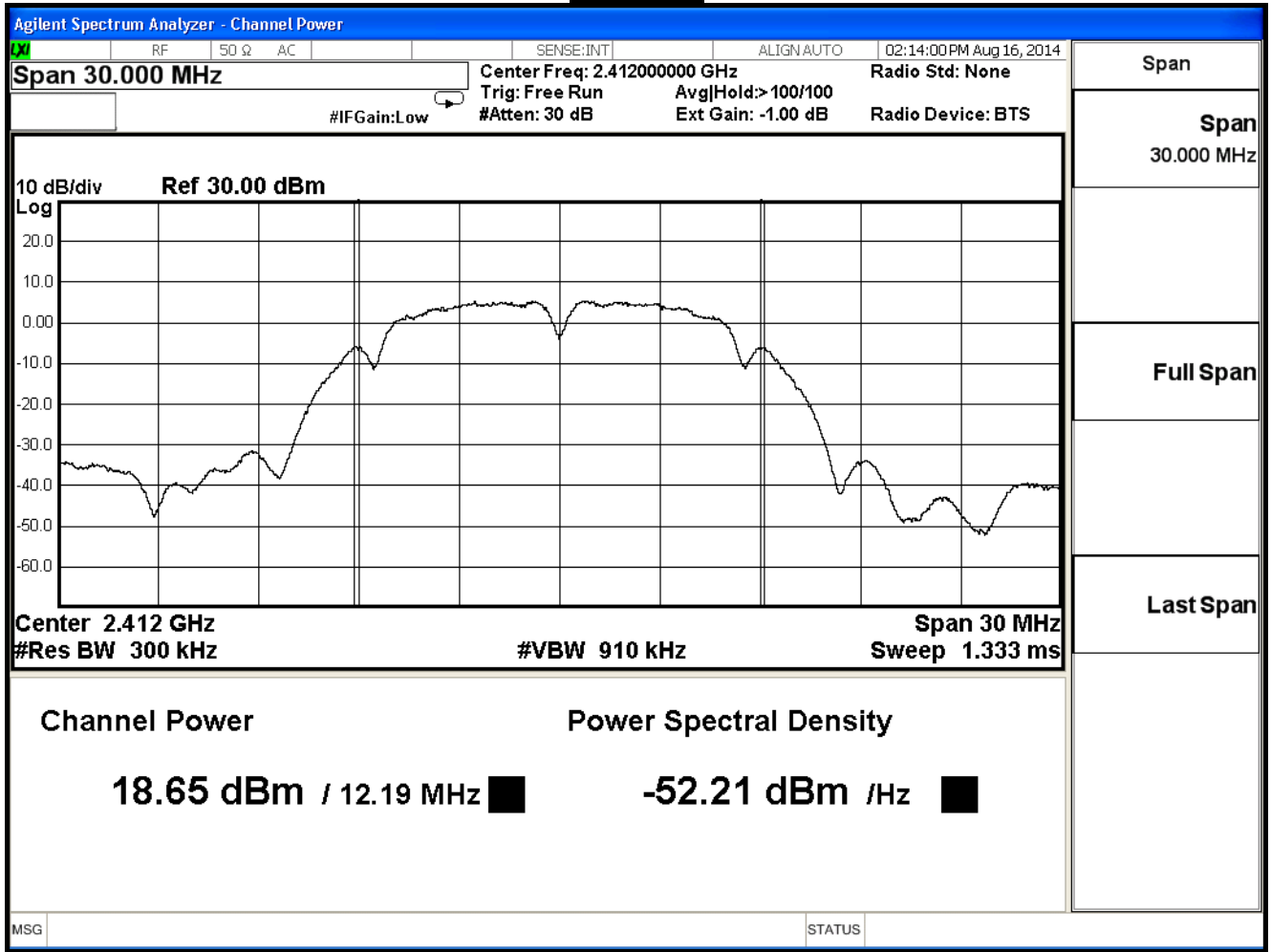

Channel 6

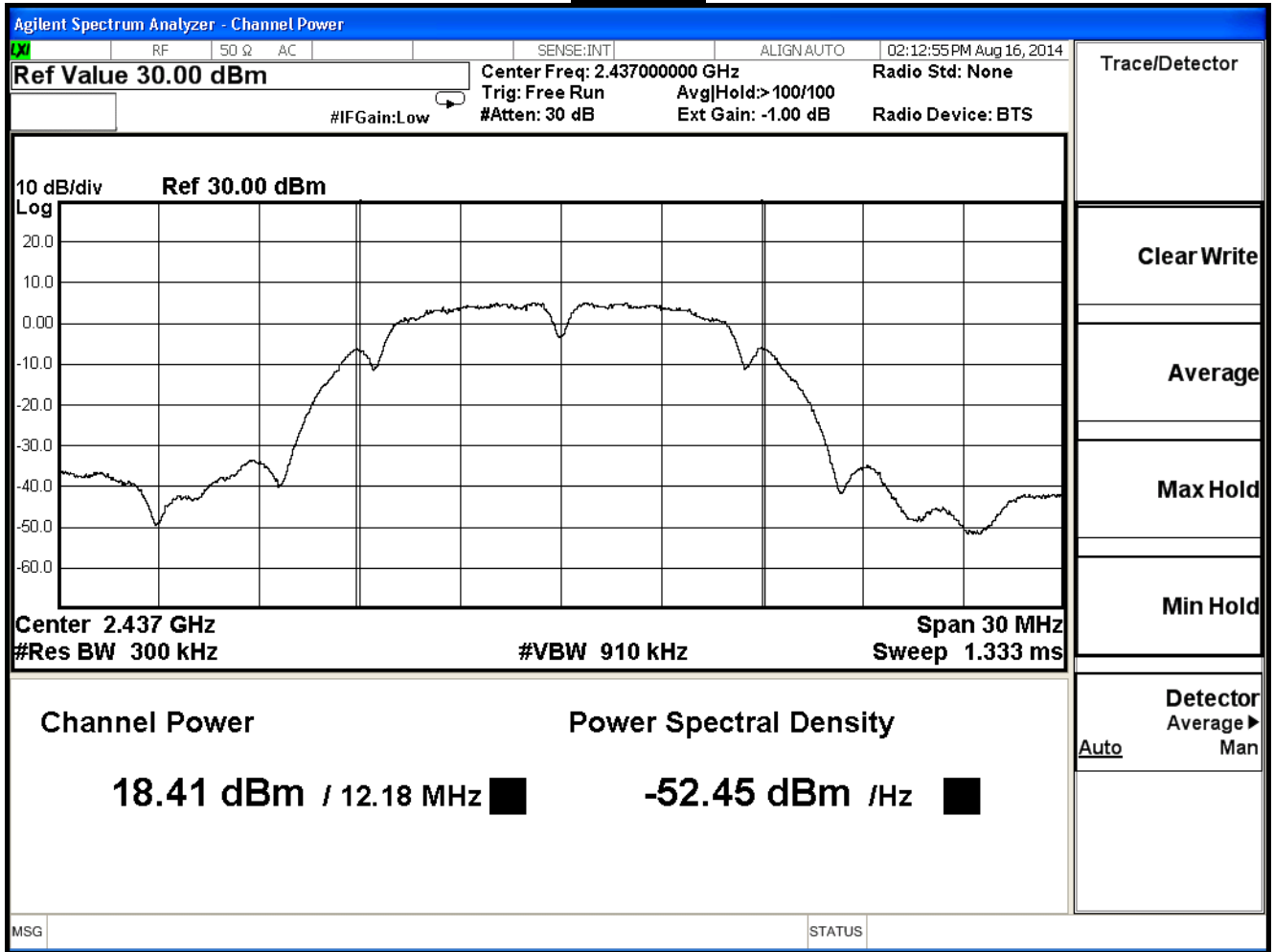

Channel 11

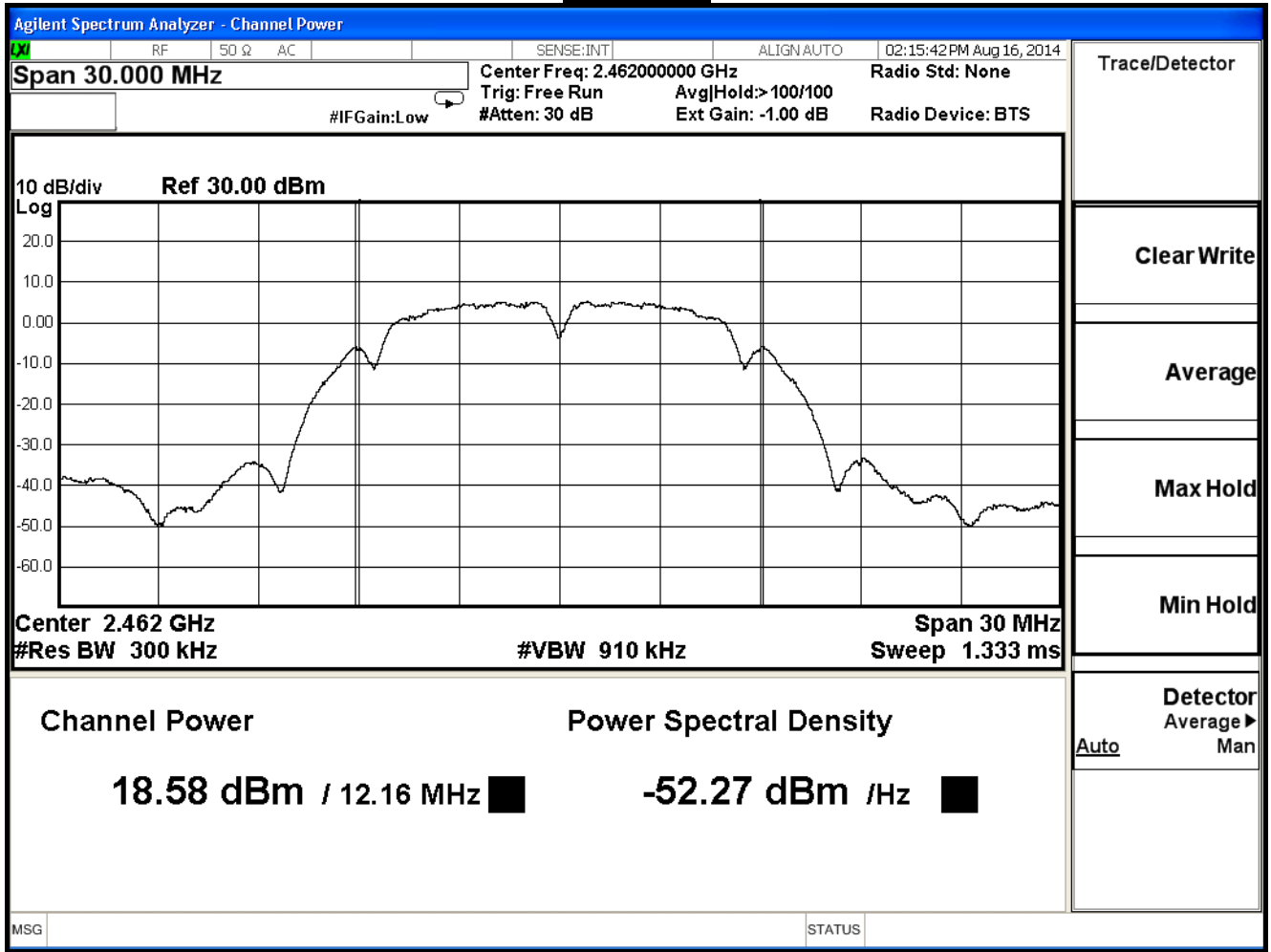

Product	WiFi HD Baby Cam		
Test Item	Peak Power Output		
Test Mode	Mode 1: Transmit		
Date of Test	2014/08/16	Test Site	SR7

IEEE 802.11g, ANT 0				
Channel No.	Frequency (MHz)	Measure Level (dBm)	Limit (dBm)	Result
1	2412	14.58	≤ 30	Pass
6	2437	18.64	≤ 30	Pass
11	2462	13.21	≤ 30	Pass

The worst emission of data rate is 6Mbps.

Peak Power Output (dBm)									
Channel No	Frequency (MHz)	Data Rate							Required Limit
		6	12	18	24	36	48	54	
1	2412	14.58	--	--	--	--	--	--	1 Watt=30dBm
6	2437	18.64	18.54	18.43	18.17	17.93	17.71	17.47	1 Watt=30dBm
11	2462	13.21	--	--	--	--	--	--	1 Watt=30dBm

Note: Measure Level =Reading value + cable loss

## Channel 1

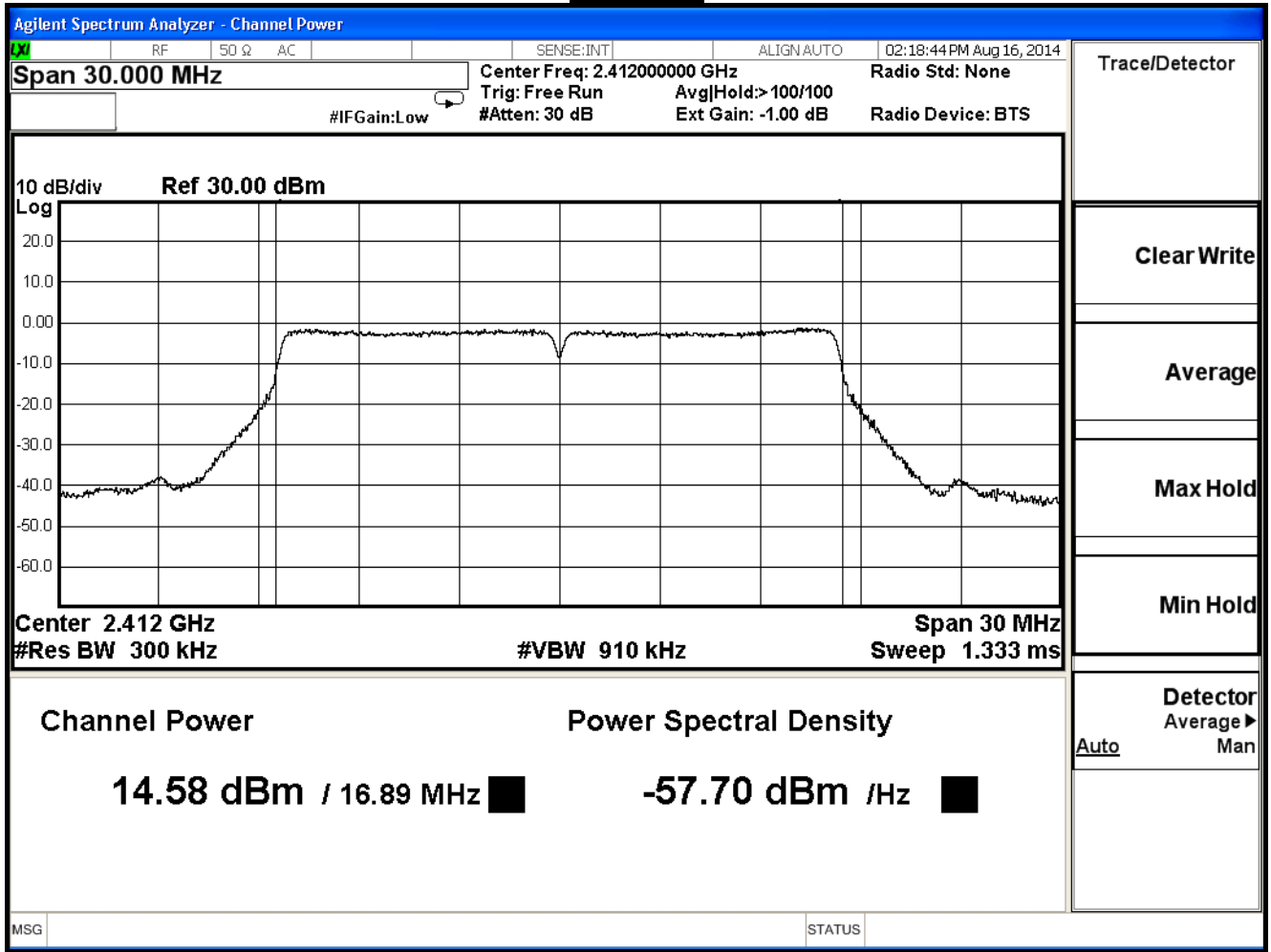



## Channel 6

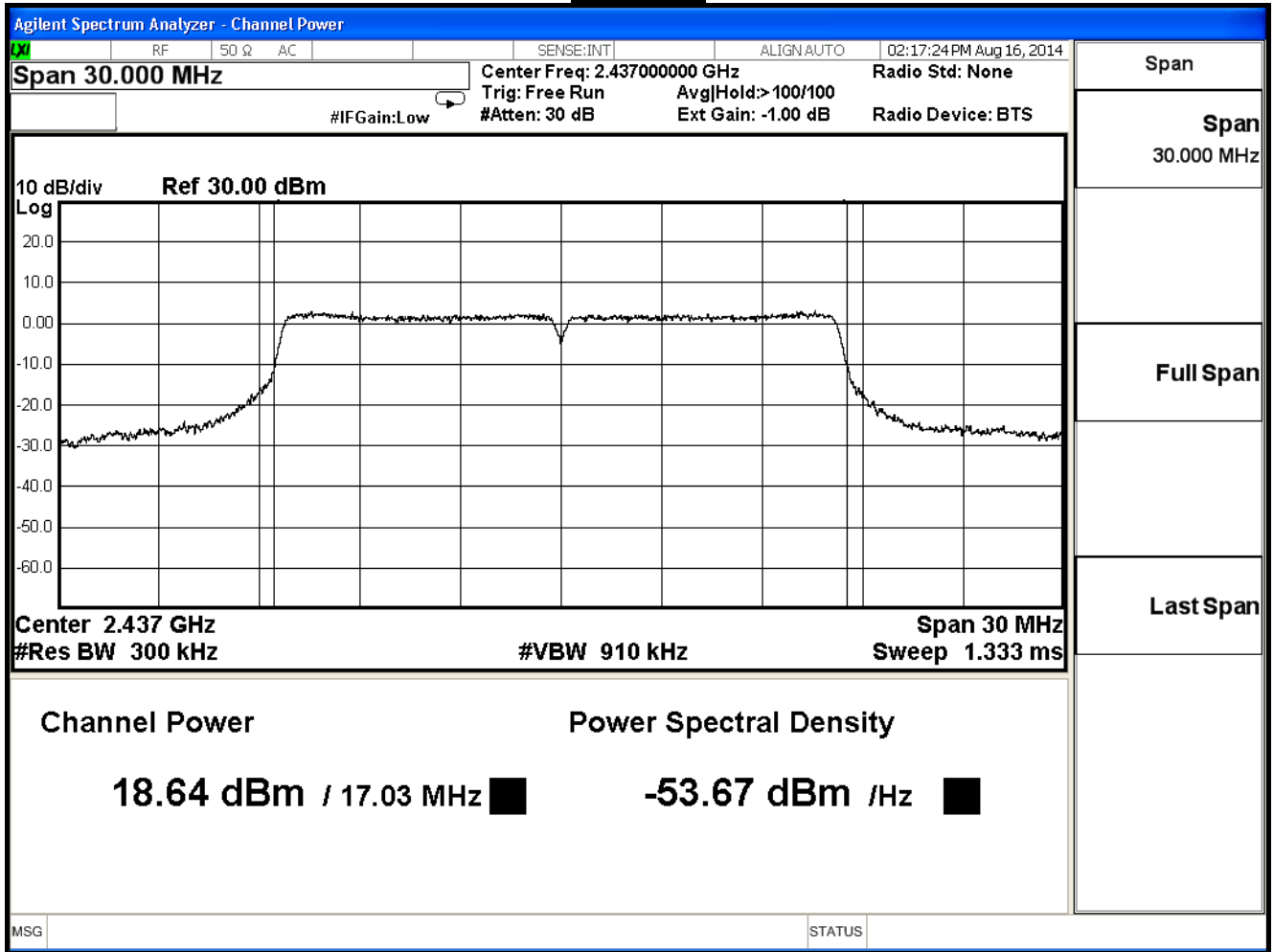

Channel 11

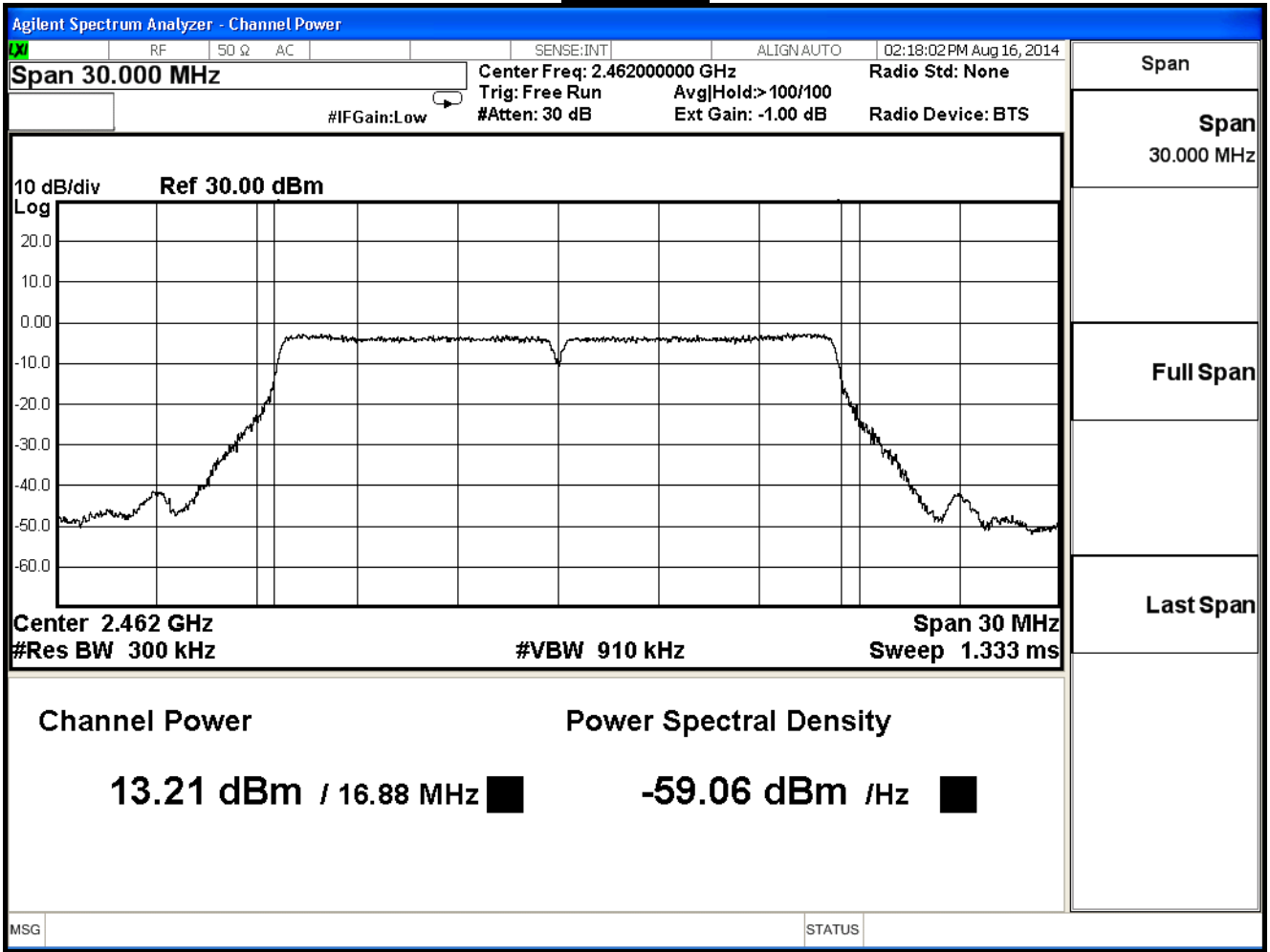

Product	WiFi HD Baby Cam		
Test Item	Peak Power Output		
Test Mode	Mode 1: Transmit		
Date of Test	2014/08/16	Test Site	SR7

IEEE 802.11n 20MHz, ANT 0

Channel No.	Frequency (MHz)	Measure Level (dBm)	Limit (dBm)	Result
1	2412	13.00	≤ 30	Pass
6	2437	16.83	≤ 30	Pass
11	2462	12.63	≤ 30	Pass

The worst emission of data rate is 6.5 Mbps.

Peak Power Output (dBm)										
MCS Index		0	1	2	3	4	5	6	7	Required Limit
Channel No	Frequency (MHz)	Data Rate								
		6.5	13	19.5	26	39	52	58.5	65	
1	2412	13	--	--	--	--	--	--	--	1Watt=30dBm
6	2437	16.83	16.59	16.39	16.28	16.15	16.03	15.79	15.68	1Watt=30dBm
11	2462	12.63	--	--	--	--	--	--	--	1Watt=30dBm

Note: Measure Level = Reading value + cable loss

Channel 1

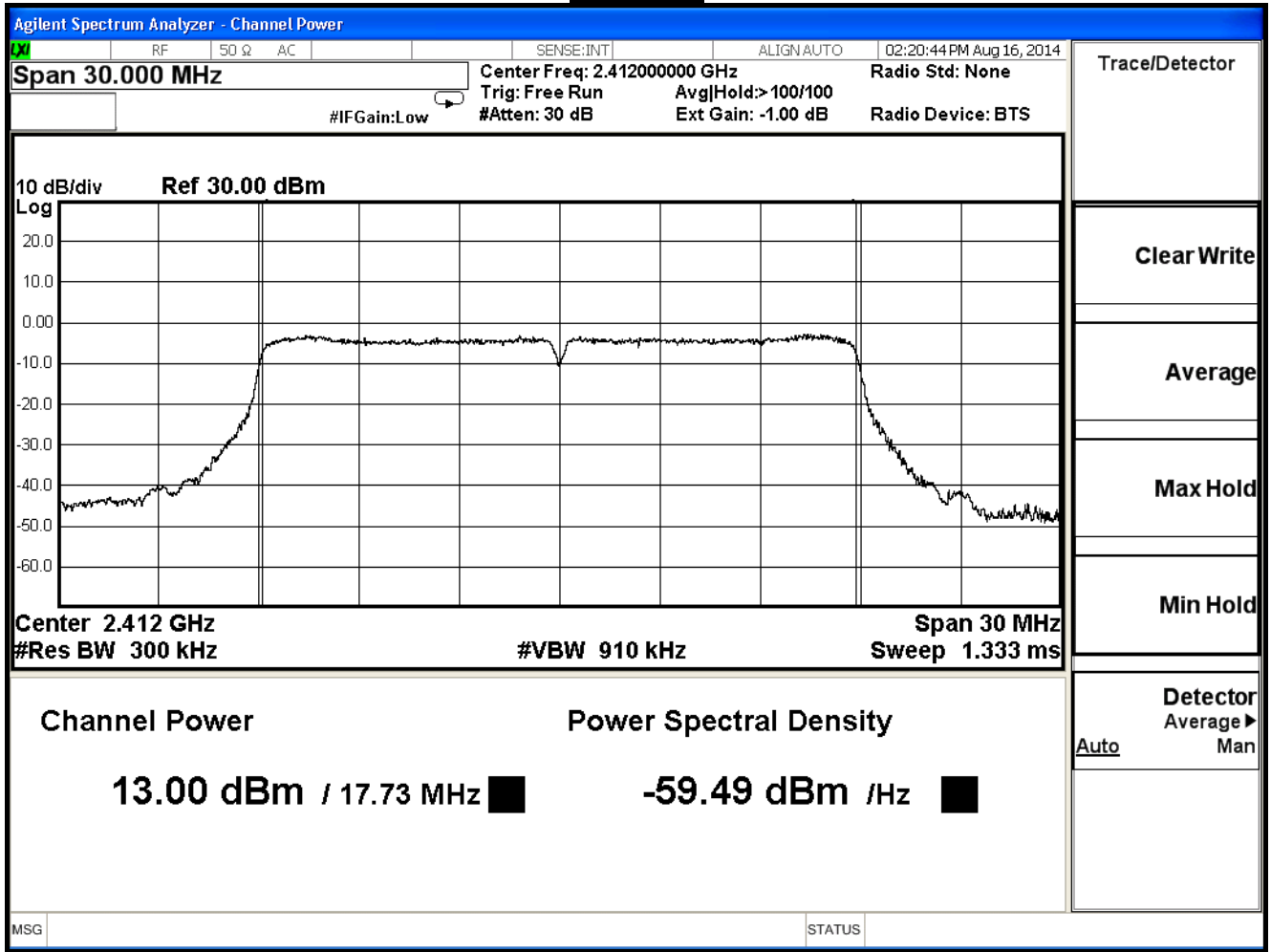

## Channel 6

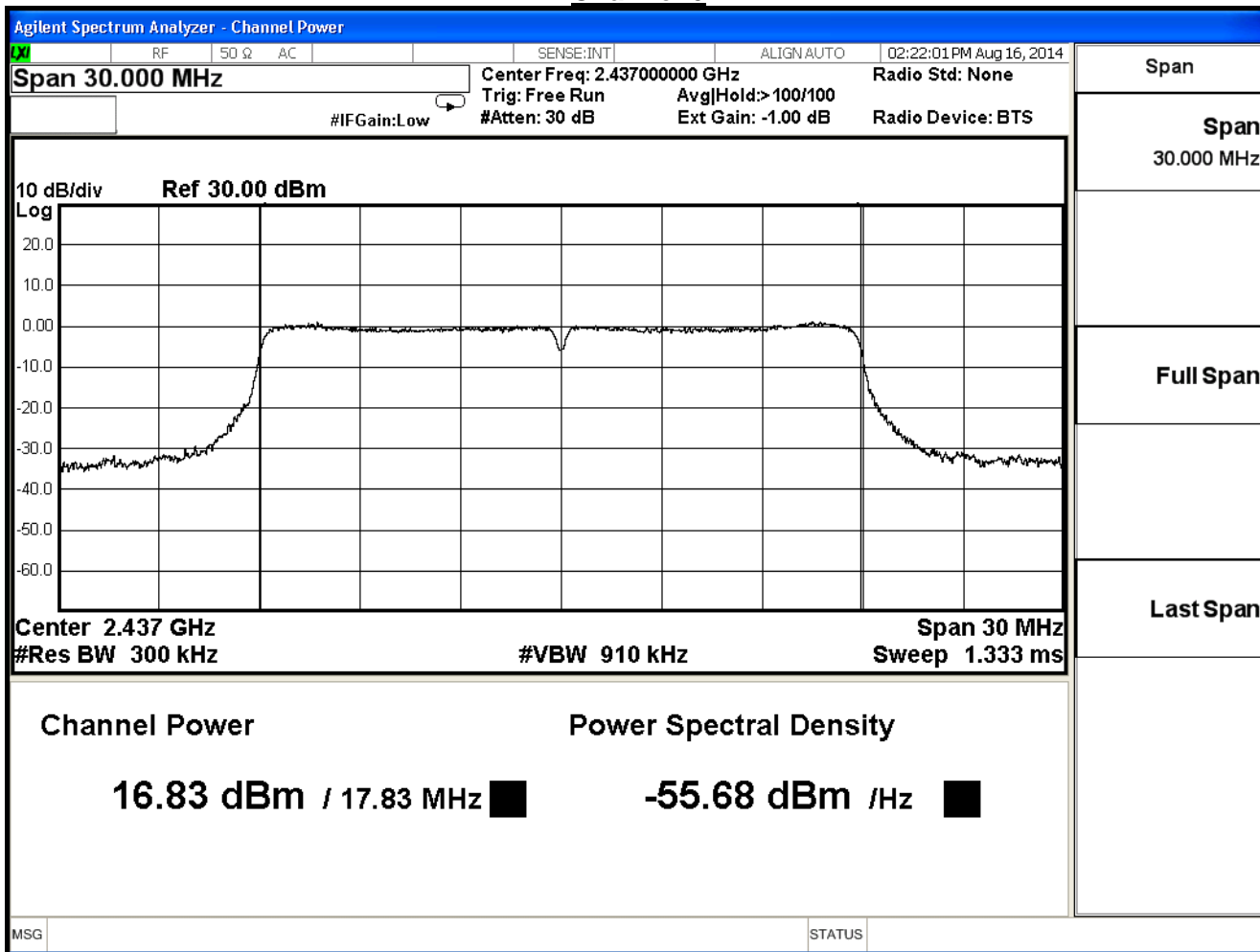

Channel 11

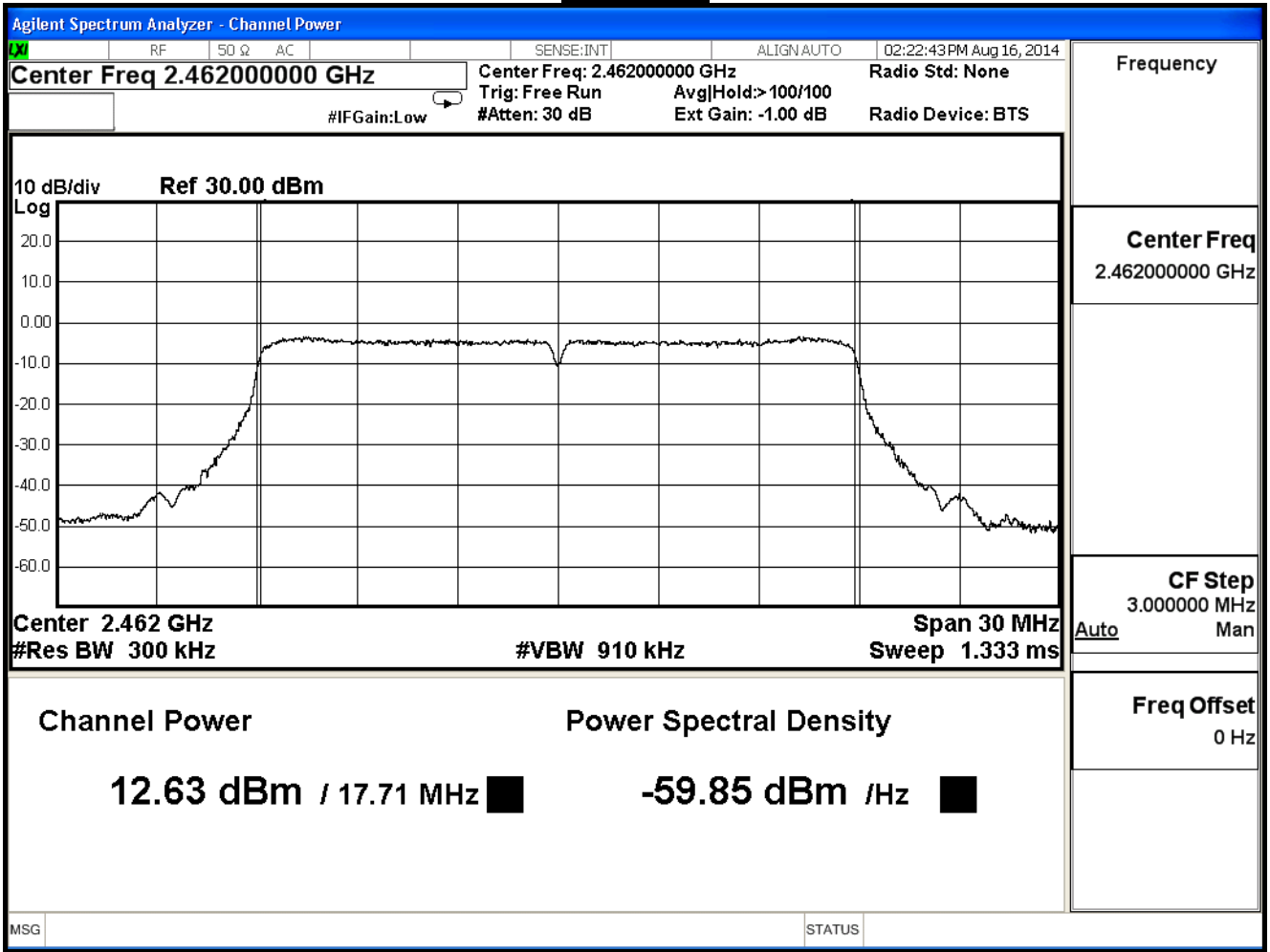

4. Radiated Emission

4.1. Test Equipment

The following test equipments are used during the test:

Radiated Emission / CB1

Instrument	Manufacturer	Model No.	Serial No	Next Cal. Date
Bilog Antenna	SCHAFFNER	CBL6112B	2895(CB1)	2015/08/14
Double Ridged Guide Horn Antenna	Schwarzback	BBHA 9120	D743	2015/02/12
Pre-Amplifier	MITEQ	AMF-4D-005180-24-10P	888003	2015/06/02
Pre-Amplifier	QuieTek	AP-025C	CHM-0706049	2015/02/06
Spectrum Analyzer	Agilent	E4440A	MY46187335	2015/01/12
k Type Cable	Huber Suhner	Sucoflex 102	25623/2	2015/02/10

Note: 1. All equipments that need to calibrate are with calibration period of 1 year.

4.2. Test Setup

Under 1GHz Test Setup:

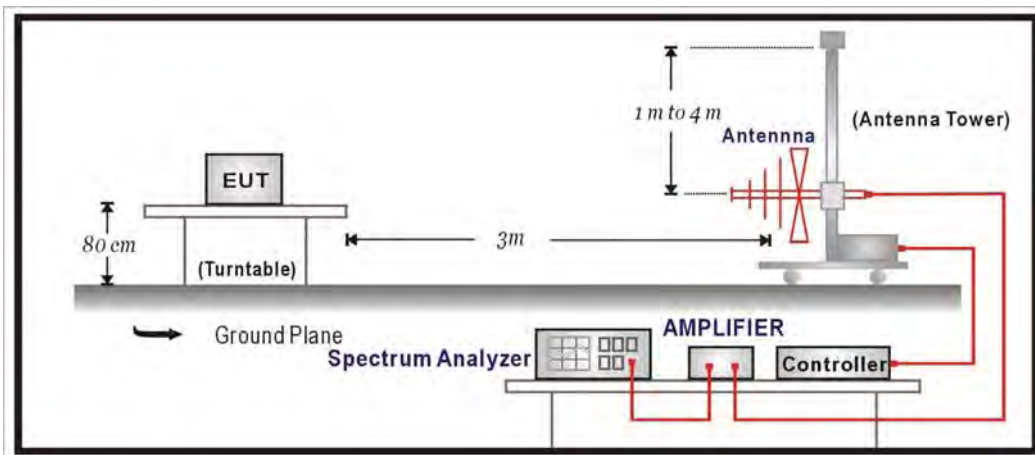

Above 1GHz Test Setup:

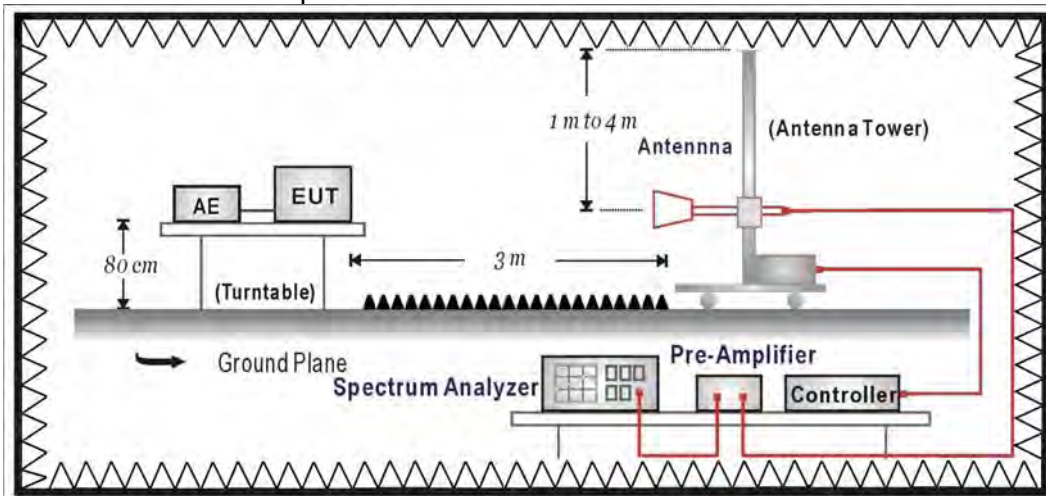

**4.3. Limits**

Emissions radiated outside of the specified frequency bands, except for harmonics, shall be attenuated by at least 20dB below the level of the fundamental or to the general radiated emission limits in paragraph 15.209, whichever is the lesser attenuation.

<b>FCC Part 15 Subpart C Paragraph 15.209 Limits</b>		
Frequency MHz	dBuV/m	dBuV/m
30-88	100	40
88-216	150	43.5
216-960	200	46
Above 960	500	54

Remarks: E field strength (dBuV/m) = 20 log E field strength (uV/m)

**4.4. Test Procedure**

The EUT was setup according to ANSI C63.4: 2009 and tested according to DTS test procedure of KDB558074 v03r01 for compliance to FCC 47CFR 15.247 requirements. The EUT and its simulators are placed on a turn table which is 0.8 meter above ground. The turn table can rotate 360 degrees to determine the position of the maximum emission level. The antenna can move up and down between 1 meter and 4 meters to find out the maximum emission level.

Both horizontal and vertical polarization of the antenna are set on measurement. In order to find the maximum emission, all of the interface cables must be manipulated according to ANSI C63.4: 2009 on radiated measurement.

On any frequency or frequencies below or equal to 1000 MHz, the limits shown are based on measuring equipment employing a quasi-peak detector function and on any frequency or frequencies above 1000 MHz the radiated limits shown are based upon the use of measurement instrumentation employing an average detector function. When average radiated emission measurement are included emission measurement below 1000 MHz, there also is a limit on the radio frequency emissions, as measured using instrumentation with a peak detector function, corresponding to 20 dB above the maximum permitted average limit. The bandwidth below 1GHz setting on the field strength meter is 120 kHz and above 1GHz is 1MHz.

**4.5. Test Specification**

According to FCC Part 15 Subpart C Paragraph 15.247: 2013

**4.6. Uncertainty**

The measurement uncertainty

30MHz~1GHz as ±3.43dB

1GHz~26.5Ghz as ±3.65dB



## 4.7. Test Result

### 30MHz-1GHz Spurious

Site : CB1	Time : 2014/08/23 - 12:51
Limit : FCC_CLASS_B_03M_QP	Margin : 6
Probe : CB1_FCC_30M-1G-4_9161 - HORIZONTAL	Power : AC 120V/60Hz
EUT : WiFi HD Baby Cam	Note : 802.11b_CH6

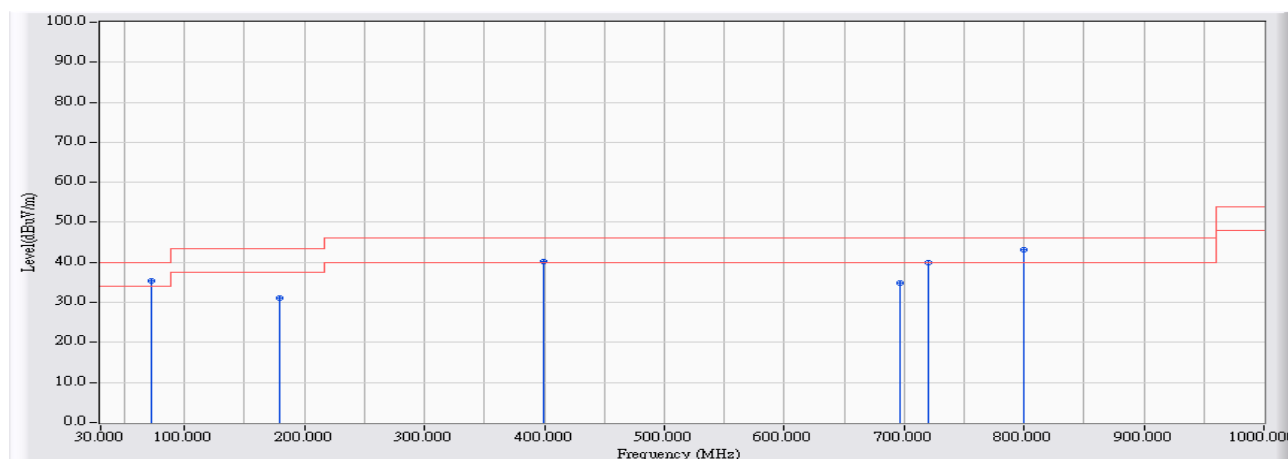

	Frequency (MHz)	Correct Factor (dB)	Reading Level (dBuV)	Measure Level (dBuV/m)	Margin (dB)	Limit (dBuV/m)	Detector Type
1	71.710	-24.777	60.164	35.386	-4.614	40.000	QUASPEAK
2	179.380	-18.359	49.421	31.062	-12.438	43.500	QUASPEAK
3	399.570	-16.531	56.741	40.209	-5.791	46.000	QUASPEAK
4	696.390	-9.344	44.072	34.728	-11.272	46.000	QUASPEAK
5	719.670	-9.304	49.134	39.830	-6.170	46.000	QUASPEAK
6	* 800.180	-8.477	51.681	43.204	-2.796	46.000	QUASPEAK

Note:

1. All Reading Levels are Quasi-Peak value.
2. “ \* ”, means this data is the worst emission level.
3. Measurement Level = Reading Level + Correct Factor.

Site : CB1	Time : 2014/08/23 - 12:51
Limit : FCC_CLASS_B_03M_QP	Margin : 6
Probe : CB1_FCC_30M-1G-4_9161 - VERTICAL	Power : AC 120V/60Hz
EUT : WiFi HD Baby Cam	Note : 802.11b_CH6

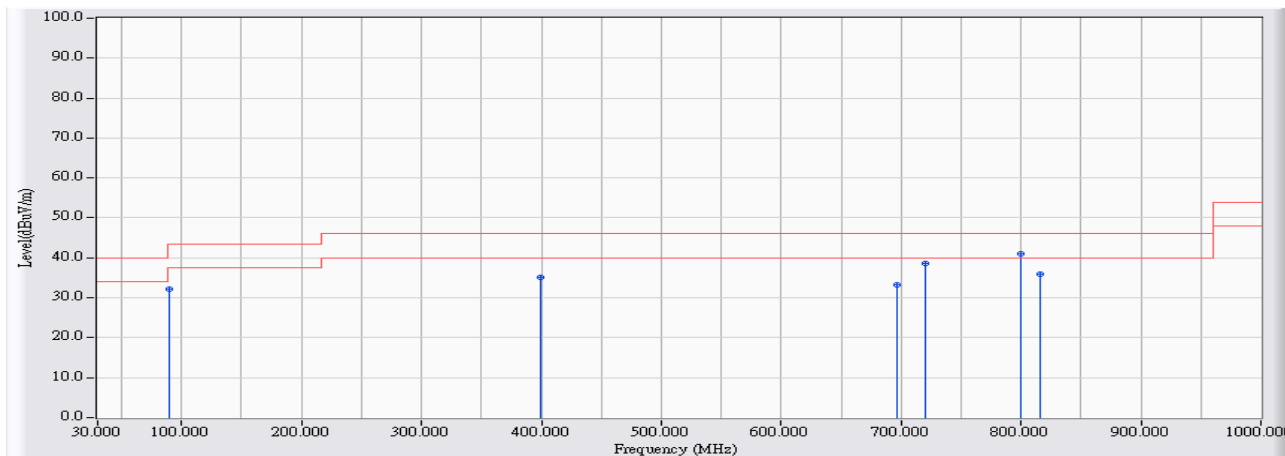

	Frequency (MHz)	Correct Factor (dB)	Reading Level (dBuV)	Measure Level (dBuV/m)	Margin (dB)	Limit (dBuV/m)	Detector Type
1	90.140	-21.465	53.544	32.079	-11.421	43.500	QUASPEAK
2	399.570	-16.531	51.760	35.228	-10.772	46.000	QUASPEAK
3	696.390	-9.344	42.624	33.280	-12.720	46.000	QUASPEAK
4	719.670	-9.304	47.891	38.587	-7.413	46.000	QUASPEAK
5	* 800.180	-8.477	49.414	40.937	-5.063	46.000	QUASPEAK
6	815.700	-8.278	44.236	35.958	-10.042	46.000	QUASPEAK

**Note:**

1. All Reading Levels are Quasi-Peak value.
2. “ \* ”, means this data is the worst emission level.
3. Measurement Level = Reading Level + Correct Factor.

Site : CB1	Time : 2014/08/23 - 12:51
Limit : FCC_CLASS_B_03M_QP	Margin : 6
Probe : CB1_FCC_30M-1G-4_9161 - HORIZONTAL	Power : AC 120V/60Hz
EUT : WiFi HD Baby Cam	Note : 802.11g_CH6

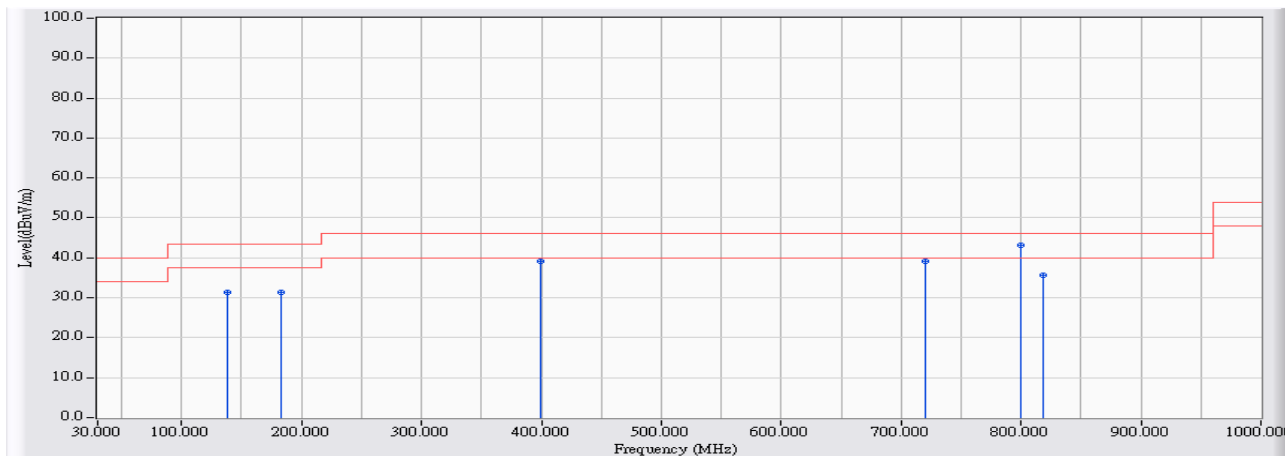

	Frequency (MHz)	Correct Factor (dB)	Reading Level (dBuV)	Measure Level (dBuV/m)	Margin (dB)	Limit (dBuV/m)	Detector Type
1	138.640	-17.248	48.554	31.305	-12.195	43.500	QUASPEAK
2	183.260	-18.967	50.253	31.286	-12.214	43.500	QUASPEAK
3	399.570	-16.531	55.683	39.151	-6.849	46.000	QUASPEAK
4	719.670	-9.304	48.494	39.190	-6.810	46.000	QUASPEAK
5	* 800.180	-8.477	51.539	43.062	-2.938	46.000	QUASPEAK
6	818.610	-8.241	43.840	35.599	-10.401	46.000	QUASPEAK

**Note:**

1. All Reading Levels are Quasi-Peak value.
2. “ \* ”, means this data is the worst emission level.
3. Measurement Level = Reading Level + Correct Factor.

Site : CB1	Time : 2014/08/23 - 12:52
Limit : FCC_CLASS_B_03M_QP	Margin : 6
Probe : CB1_FCC_30M-1G-4_9161 - VERTICAL	Power : AC 120V/60Hz
EUT : WiFi HD Baby Cam	Note : 802.11g_CH6

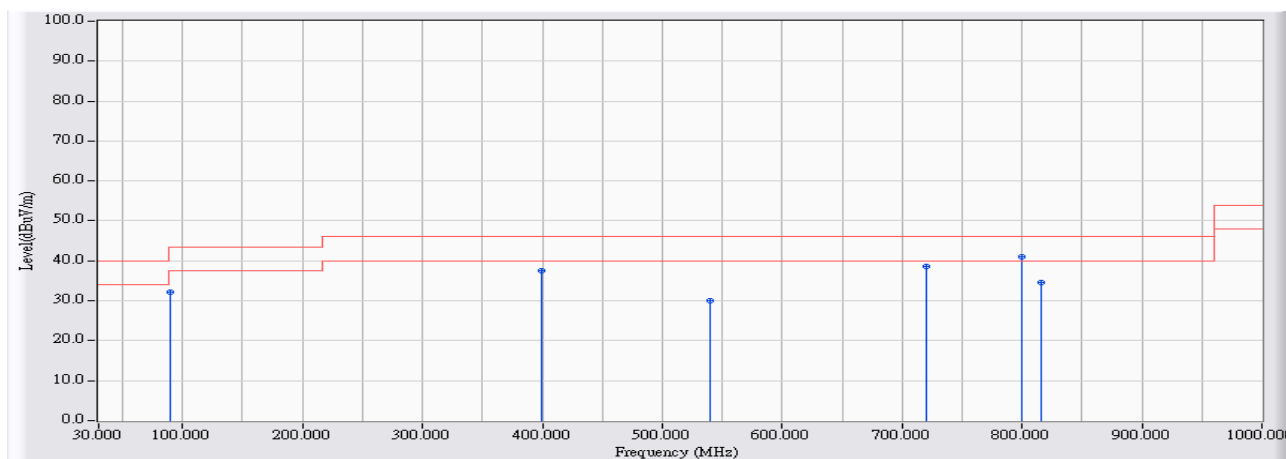

	Frequency (MHz)	Correct Factor (dB)	Reading Level (dBuV)	Measure Level (dBuV/m)	Margin (dB)	Limit (dBuV/m)	Detector Type
1	90.140	-21.465	53.520	32.055	-11.445	43.500	QUASPEAK
2	399.570	-16.531	54.178	37.646	-8.354	46.000	QUASPEAK
3	540.220	-13.519	43.513	29.994	-16.006	46.000	QUASPEAK
4	719.670	-9.304	47.837	38.533	-7.467	46.000	QUASPEAK
5	* 800.180	-8.477	49.575	41.098	-4.902	46.000	QUASPEAK
6	815.700	-8.278	42.879	34.601	-11.399	46.000	QUASPEAK

**Note:**

1. All Reading Levels are Quasi-Peak value.
2. “ \* ”, means this data is the worst emission level.
3. Measurement Level = Reading Level + Correct Factor.

Site : CB1	Time : 2014/08/23 - 12:52
Limit : FCC_CLASS_B_03M_QP	Margin : 6
Probe : CB1_FCC_30M-1G-4_9161 - HORIZONTAL	Power : AC 120V/60Hz
EUT : WiFi HD Baby Cam	Note : 802.11n 20MHz_CH6

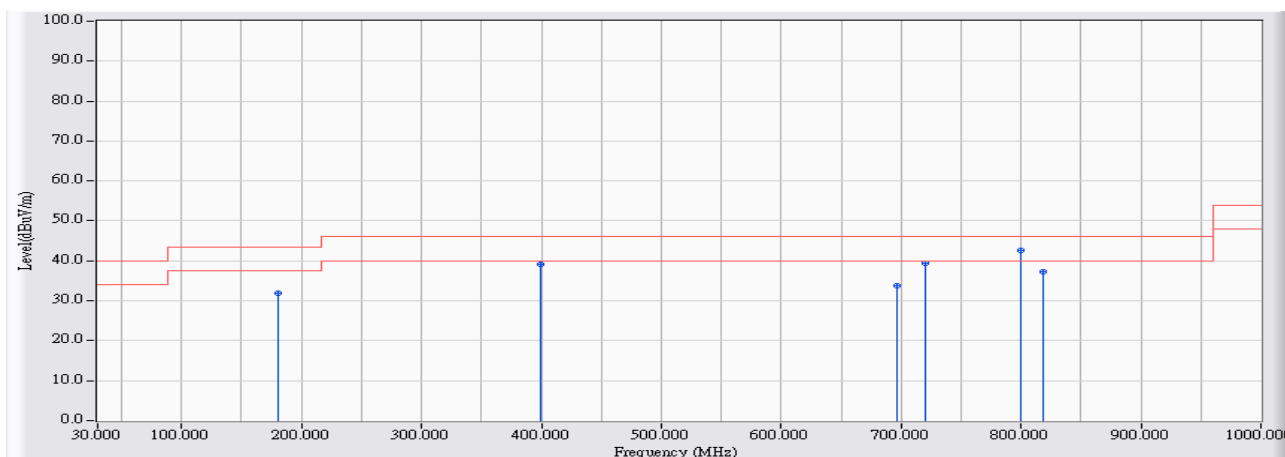

	Frequency (MHz)	Correct Factor (dB)	Reading Level (dBuV)	Measure Level (dBuV/m)	Margin (dB)	Limit (dBuV/m)	Detector Type
1	180.350	-18.510	50.357	31.847	-11.653	43.500	QUASPEAK
2	399.570	-16.531	55.790	39.258	-6.742	46.000	QUASPEAK
3	696.390	-9.344	43.048	33.704	-12.296	46.000	QUASPEAK
4	719.670	-9.304	48.613	39.309	-6.691	46.000	QUASPEAK
5	* 800.180	-8.477	51.031	42.554	-3.446	46.000	QUASPEAK
6	818.610	-8.241	45.501	37.260	-8.740	46.000	QUASPEAK

**Note:**

1. All Reading Levels are Quasi-Peak value.
2. “ \* ”, means this data is the worst emission level.
3. Measurement Level = Reading Level + Correct Factor.

Site : CB1	Time : 2014/08/23 - 12:52
Limit : FCC_CLASS_B_03M_QP	Margin : 6
Probe : CB1_FCC_30M-1G-4_9161 - VERTICAL	Power : AC 120V/60Hz
EUT : WiFi HD Baby Cam	Note : 802.11n 20MHz_CH6

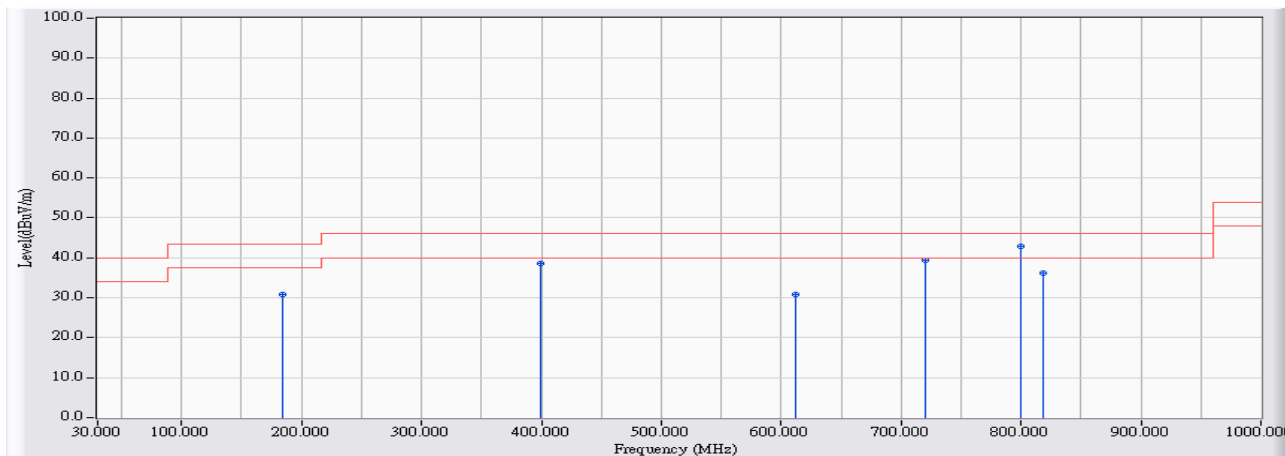

	Frequency (MHz)	Correct Factor (dB)	Reading Level (dBuV)	Measure Level (dBuV/m)	Margin (dB)	Limit (dBuV/m)	Detector Type
1	184.230	-19.119	50.074	30.955	-12.545	43.500	QUASPEAK
2	399.570	-16.531	55.039	38.507	-7.493	46.000	QUASPEAK
3	612.000	-12.033	42.921	30.888	-15.112	46.000	QUASPEAK
4	719.670	-9.304	48.596	39.292	-6.708	46.000	QUASPEAK
5	* 800.180	-8.477	51.278	42.801	-3.199	46.000	QUASPEAK
6	818.610	-8.241	44.390	36.149	-9.851	46.000	QUASPEAK

**Note:**

1. All Reading Levels are Quasi-Peak value.
2. “ \* ”, means this data is the worst emission level.
3. Measurement Level = Reading Level + Correct Factor.

Above 1GHz Spurious

Site : CB1	Time : 2014/08/15 - 10:34
Limit : FCC_SpartC_15.247_H_03M_PK	Margin : 6
Probe : CB1_FCC_EFS_1-18G-1_0901 - HORIZONTAL	Power : AC 120V/60Hz
EUT : WIFI HD BABY CAM	Note : 802.11b_CH01

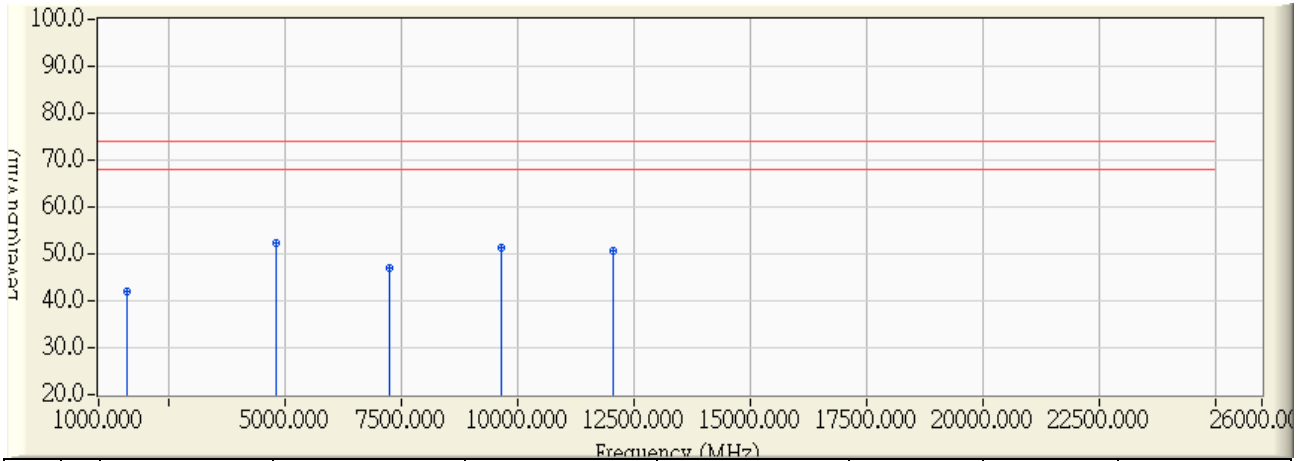

	Frequency (MHz)	Correct Factor (dB)	Reading Level (dBuV)	Measure Level (dBuV/m)	Margin (dB)	Limit (dBuV/m)	Detector Type
1	1600.230	-8.711	50.570	41.858	-32.142	74.000	PEAK
2	* 4824.010	-0.534	53.020	52.486	-21.514	74.000	PEAK
3	7237.590	5.522	41.600	47.122	-26.878	74.000	PEAK
4	9648.170	9.447	41.820	51.267	-22.733	74.000	PEAK
5	12062.680	11.099	39.600	50.699	-23.301	74.000	PEAK

Note:

1. All readings above 1GHz are performed with peak and/or average measurements as necessary.
2. Peak measurements: RBW = 1MHz, VBW = 3 MHz, Sweep: Auto.
3. Average measurements: RBW = 1MHz, VBW = 10 Hz, Sweep: Auto.
4. “ \* ”, means this data is the worst emission level.
5. Measurement Level = Reading Level + Correct Factor.
6. The average measurement was not performed when the peak measured data under the limit of average detection.
7. The Emission above 18GHz were not included is because their levels are too low.

Site : CB1	Time : 2014/08/15 - 10:46
Limit : FCC_SpartC_15.247_H_03M_PK	Margin : 6
Probe : CB1_FCC_EFS_1-18G-1_0901 - VERTICAL	Power : AC 120V/60Hz
EUT : WIFI HD BABY CAM	Note : 802.11b_CH01

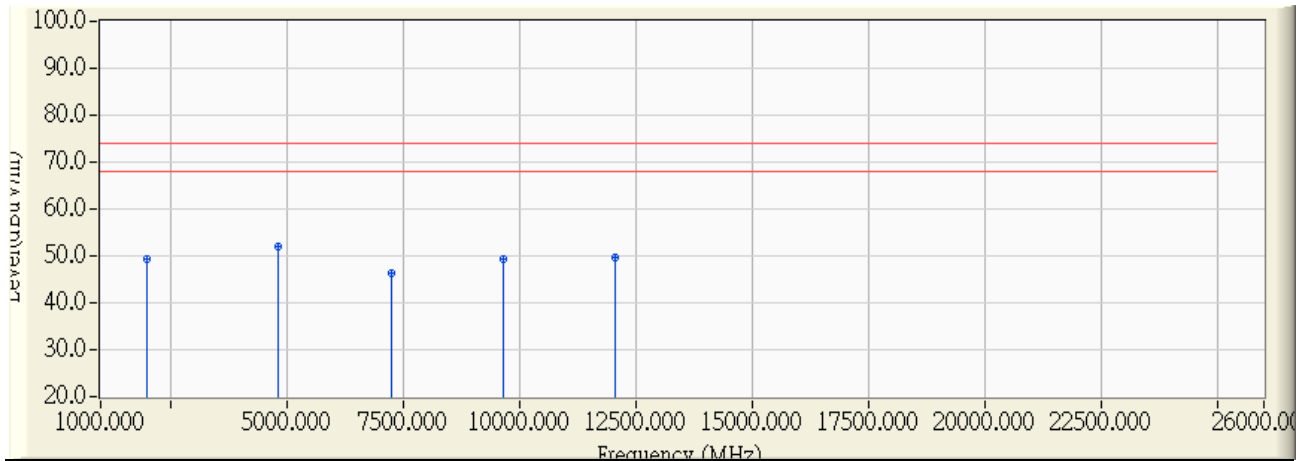

	Frequency (MHz)	Correct Factor (dB)	Reading Level (dBuV)	Measure Level (dBuV/m)	Margin (dB)	Limit (dBuV/m)	Detector Type
1	1999.000	-7.226	56.480	49.253	-24.747	74.000	PEAK
2	* 4824.030	-0.534	52.460	51.926	-22.074	74.000	PEAK
3	7237.220	5.521	40.730	46.251	-27.749	74.000	PEAK
4	9648.060	9.446	39.880	49.326	-24.674	74.000	PEAK
5	12061.940	11.100	38.630	49.729	-24.271	74.000	PEAK

**Note:**

1. All readings above 1GHz are performed with peak and/or average measurements as necessary.
2. Peak measurements: RBW = 1MHz, VBW = 3 MHz, Sweep: Auto.
3. Average measurements: RBW = 1MHz, VBW = 10 Hz, Sweep: Auto.
4. “ \* ”, means this data is the worst emission level.
5. Measurement Level = Reading Level + Correct Factor.
6. The average measurement was not performed when the peak measured data under the limit of average detection.
7. The Emission above 18GHz were not included is because their levels are too low.



Site : CB1	Time : 2014/08/15 - 10:53
Limit : FCC_SpartC_15.247_H_03M_PK	Margin : 6
Probe : CB1_FCC_EFS_1-18G-1_0901 - HORIZONTAL	Power : AC 120V/60Hz
EUT : WIFI HD BABY CAM	Note : 802.11b_CH06

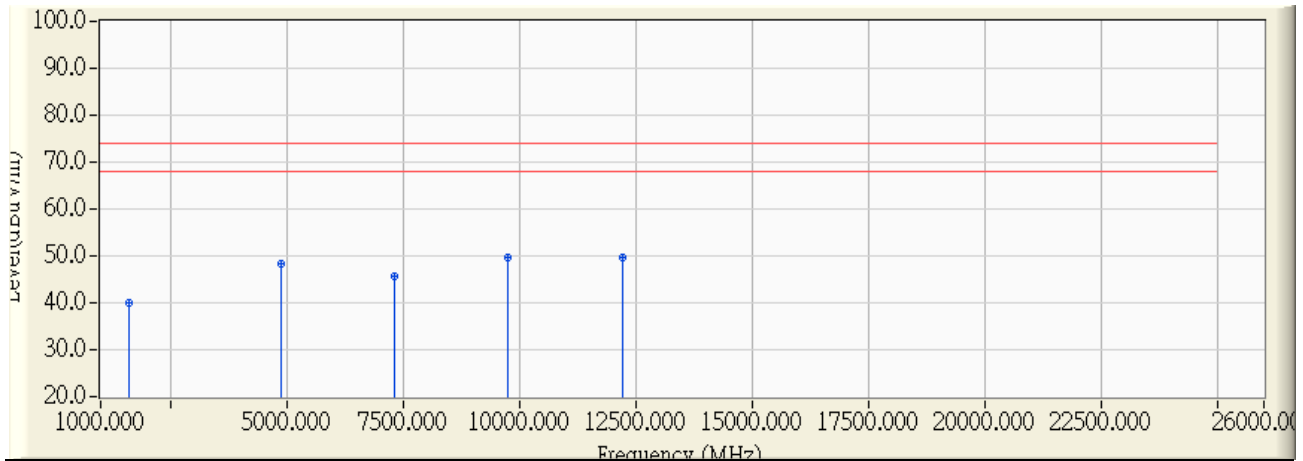

	Frequency (MHz)	Correct Factor (dB)	Reading Level (dBuV)	Measure Level (dBuV/m)	Margin (dB)	Limit (dBuV/m)	Detector Type
1	1600.000	-8.713	48.800	40.087	-33.913	74.000	PEAK
2	4874.015	-0.412	48.870	48.458	-25.542	74.000	PEAK
3	7309.805	5.679	39.890	45.568	-28.432	74.000	PEAK
4	* 9747.845	10.093	39.650	49.742	-24.258	74.000	PEAK
5	12202.050	11.036	38.550	49.585	-24.415	74.000	PEAK

**Note:**

1. All readings above 1GHz are performed with peak and/or average measurements as necessary.
2. Peak measurements: RBW = 1MHz, VBW = 3 MHz, Sweep: Auto.
3. Average measurements: RBW = 1MHz, VBW = 10 Hz, Sweep: Auto.
4. “ \* ”, means this data is the worst emission level.
5. Measurement Level = Reading Level + Correct Factor.
6. The average measurement was not performed when the peak measured data under the limit of average detection.
7. The Emission above 18GHz were not included is because their levels are too low.

Site : CB1	Time : 2014/08/15 - 11:14
Limit : FCC_SpartC_15.247_H_03M_PK	Margin : 6
Probe : CB1_FCC_EFS_1-18G-1_0901 - VERTICAL	Power : AC 120V/60Hz
EUT : WIFI HD BABY CAM	Note : 802.11b_CH06

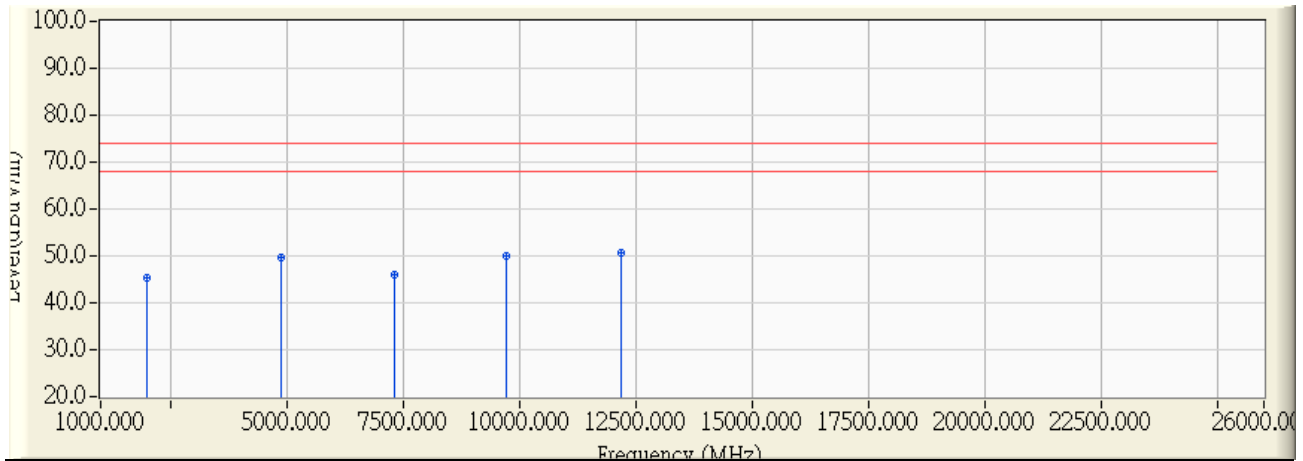

	Frequency (MHz)	Correct Factor (dB)	Reading Level (dBuV)	Measure Level (dBuV/m)	Margin (dB)	Limit (dBuV/m)	Detector Type
1	2000.000	-7.217	52.680	45.463	-28.537	74.000	PEAK
2	4873.975	-0.412	50.170	49.758	-24.242	74.000	PEAK
3	7299.850	5.657	40.360	46.017	-27.983	74.000	PEAK
4	9724.000	9.938	40.010	49.948	-24.052	74.000	PEAK
5	* 12195.275	11.038	39.740	50.778	-23.222	74.000	PEAK

**Note:**

1. All readings above 1GHz are performed with peak and/or average measurements as necessary.
2. Peak measurements: RBW = 1MHz, VBW = 3 MHz, Sweep: Auto.
3. Average measurements: RBW = 1MHz, VBW = 10 Hz, Sweep: Auto.
4. “ \* ”, means this data is the worst emission level.
5. Measurement Level = Reading Level + Correct Factor.
6. The average measurement was not performed when the peak measured data under the limit of average detection.
7. The Emission above 18GHz were not included is because their levels are too low.

Site : CB1	Time : 2014/08/15 - 11:27
Limit : FCC_SpartC_15.247_H_03M_PK	Margin : 6
Probe : CB1_FCC_EFS_1-18G-1_0901 - HORIZONTAL	Power : AC 120V/60Hz
EUT : WIFI HD BABY CAM	Note : 802.11b_CH11

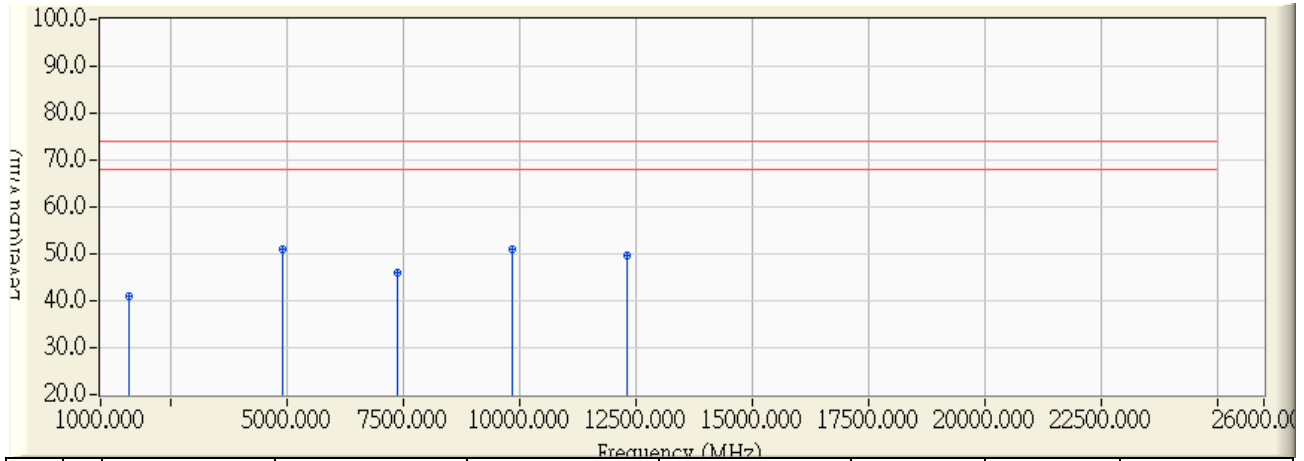

	Frequency (MHz)	Correct Factor (dB)	Reading Level (dBuV)	Measure Level (dBuV/m)	Margin (dB)	Limit (dBuV/m)	Detector Type
1	1600.000	-8.713	49.630	40.917	-33.083	74.000	PEAK
2	* 4924.012	-0.290	51.370	51.080	-22.920	74.000	PEAK
3	7386.270	5.844	40.090	45.934	-28.066	74.000	PEAK
4	9847.925	10.741	40.150	50.890	-23.110	74.000	PEAK
5	12307.940	10.987	38.690	49.677	-24.323	74.000	PEAK

**Note:**

1. All readings above 1GHz are performed with peak and/or average measurements as necessary.
2. Peak measurements: RBW = 1MHz, VBW = 3 MHz, Sweep: Auto.
3. Average measurements: RBW = 1MHz, VBW = 10 Hz, Sweep: Auto.
4. “ \* ”, means this data is the worst emission level.
5. Measurement Level = Reading Level + Correct Factor.
6. The average measurement was not performed when the peak measured data under the limit of average detection.
7. The Emission above 18GHz were not included is because their levels are too low.

Site : CB1	Time : 2014/08/15 - 11:36
Limit : FCC_SpartC_15.247_H_03M_PK	Margin : 6
Probe : CB1_FCC_EFS_1-18G-1_0901 - VERTICAL	Power : AC 120V/60Hz
EUT : WIFI HD BABY CAM	Note : 802.11b_CH11

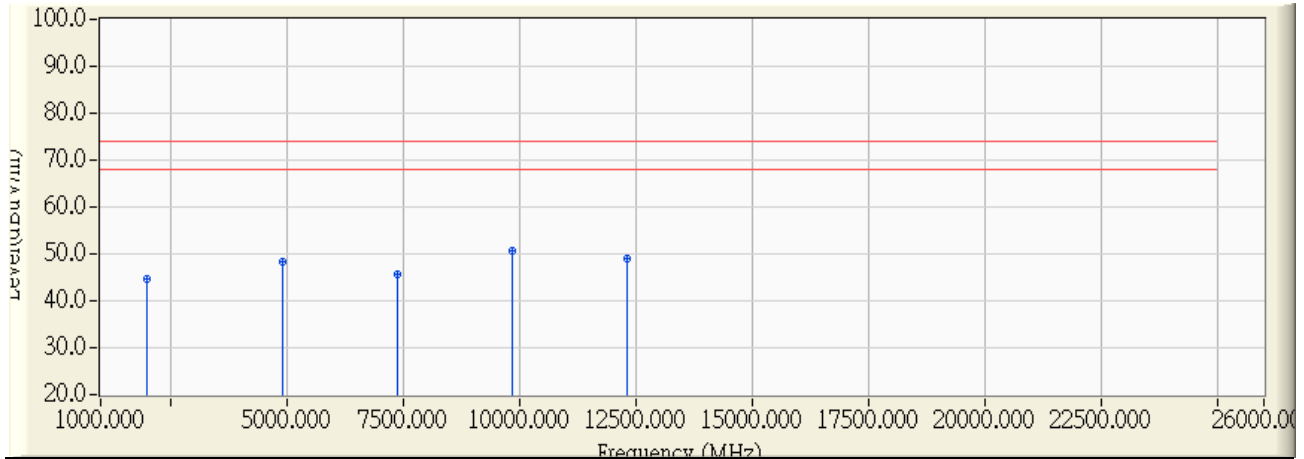

	Frequency (MHz)	Correct Factor (dB)	Reading Level (dBuV)	Measure Level (dBuV/m)	Margin (dB)	Limit (dBuV/m)	Detector Type
1	2000.000	-7.217	51.860	44.643	-29.357	74.000	PEAK
2	4923.950	-0.290	48.620	48.330	-25.670	74.000	PEAK
3	7383.360	5.838	39.870	45.708	-28.292	74.000	PEAK
4	* 9847.885	10.740	39.940	50.680	-23.320	74.000	PEAK
5	12305.470	10.989	38.070	49.058	-24.942	74.000	PEAK

**Note:**

1. All readings above 1GHz are performed with peak and/or average measurements as necessary.
2. Peak measurements: RBW = 1MHz, VBW = 3 MHz, Sweep: Auto.
3. Average measurements: RBW = 1MHz, VBW = 10 Hz, Sweep: Auto.
4. “ \* ”, means this data is the worst emission level.
5. Measurement Level = Reading Level + Correct Factor.
6. The average measurement was not performed when the peak measured data under the limit of average detection.
7. The Emission above 18GHz were not included is because their levels are too low.

Site : CB1	Time : 2014/08/15 - 11:43
Limit : FCC_SpartC_15.247_H_03M_PK	Margin : 6
Probe : CB1_FCC_EFS_1-18G-1_0901 - HORIZONTAL	Power : AC 120V/60Hz
EUT : WIFI HD BABY CAM	Note : 802.11g_CH01

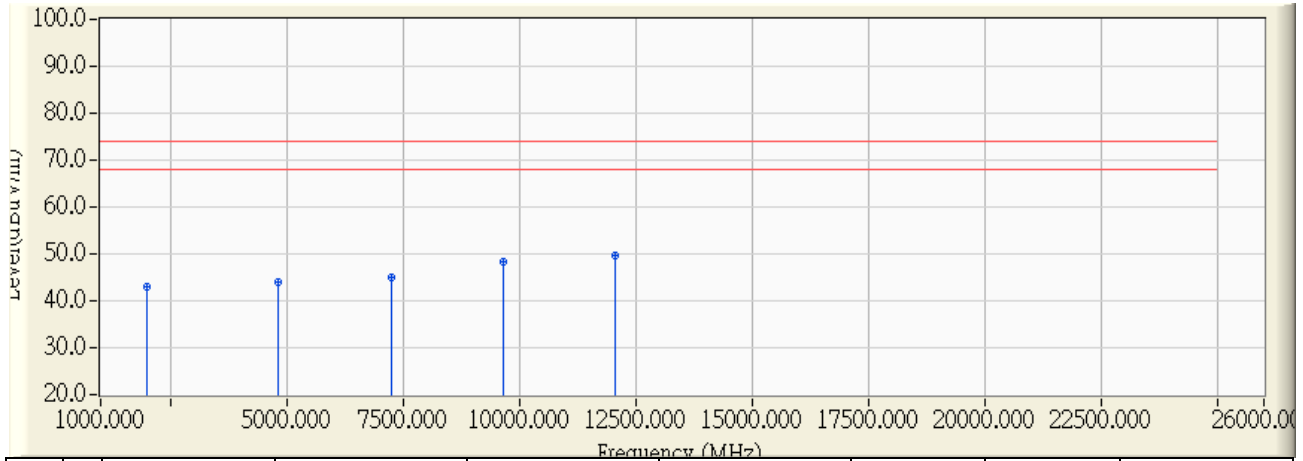

	Frequency (MHz)	Correct Factor (dB)	Reading Level (dBuV)	Measure Level (dBuV/m)	Margin (dB)	Limit (dBuV/m)	Detector Type
1	1999.000	-7.226	50.080	42.853	-31.147	74.000	PEAK
2	4821.650	-0.540	44.510	43.971	-30.029	74.000	PEAK
3	7258.125	5.567	39.490	45.057	-28.943	74.000	PEAK
4	9657.950	9.511	38.800	48.310	-25.690	74.000	PEAK
5	* 12059.625	11.100	38.550	49.650	-24.350	74.000	PEAK

**Note:**

1. All readings above 1GHz are performed with peak and/or average measurements as necessary.
2. Peak measurements: RBW = 1MHz, VBW = 3 MHz, Sweep: Auto.
3. Average measurements: RBW = 1MHz, VBW = 10 Hz, Sweep: Auto.
4. “ \* ”, means this data is the worst emission level.
5. Measurement Level = Reading Level + Correct Factor.
6. The average measurement was not performed when the peak measured data under the limit of average detection.
7. The Emission above 18GHz were not included is because their levels are too low.

Site : CB1	Time : 2014/08/15 - 11:50
Limit : FCC_SpartC_15.247_H_03M_PK	Margin : 6
Probe : CB1_FCC_EFS_1-18G-1_0901 - VERTICAL	Power : AC 120V/60Hz
EUT : WIFI HD BABY CAM	Note : 802.11g_CH01

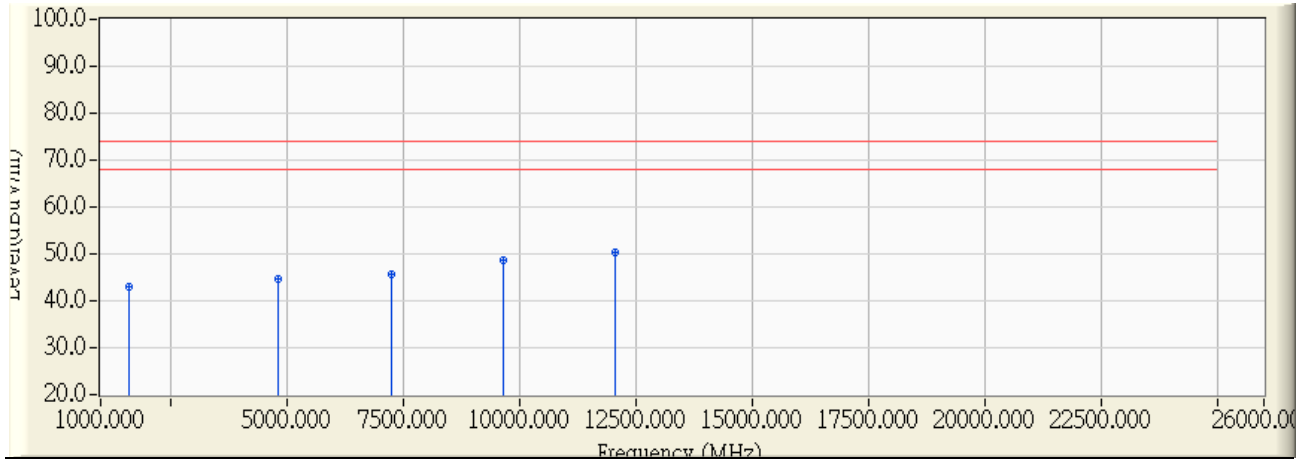

	Frequency (MHz)	Correct Factor (dB)	Reading Level (dBuV)	Measure Level (dBuV/m)	Margin (dB)	Limit (dBuV/m)	Detector Type
1	1600.000	-8.713	51.810	43.097	-30.903	74.000	PEAK
2	4828.250	-0.524	45.090	44.567	-29.433	74.000	PEAK
3	7238.750	5.524	39.990	45.515	-28.485	74.000	PEAK
4	9645.560	9.430	39.180	48.610	-25.390	74.000	PEAK
5	* 12063.240	11.099	39.200	50.298	-23.702	74.000	PEAK

**Note:**

1. All readings above 1GHz are performed with peak and/or average measurements as necessary.
2. Peak measurements: RBW = 1MHz, VBW = 3 MHz, Sweep: Auto.
3. Average measurements: RBW = 1MHz, VBW = 10 Hz, Sweep: Auto.
4. “ \* ”, means this data is the worst emission level.
5. Measurement Level = Reading Level + Correct Factor.
6. The average measurement was not performed when the peak measured data under the limit of average detection.
7. The Emission above 18GHz were not included is because their levels are too low.

Site : CB1	Time : 2014/08/15 - 12:01
Limit : FCC_SpartC_15.247_H_03M_PK	Margin : 6
Probe : CB1_FCC_EFS_1-18G-1_0901 - HORIZONTAL	Power : AC 120V/60Hz
EUT : WIFI HD BABY CAM	Note : 802.11g_CH06

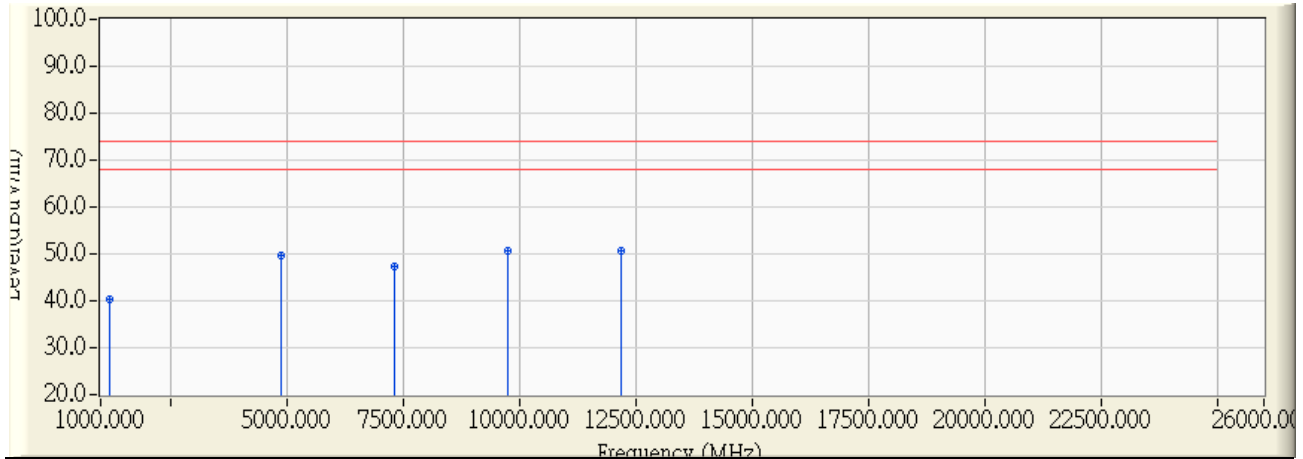

	Frequency (MHz)	Correct Factor (dB)	Reading Level (dBuV)	Measure Level (dBuV/m)	Margin (dB)	Limit (dBuV/m)	Detector Type
1	1199.500	-10.502	50.740	40.238	-33.762	74.000	PEAK
2	4871.625	-0.418	50.250	49.833	-24.167	74.000	PEAK
3	7307.675	5.674	41.730	47.404	-26.596	74.000	PEAK
4	* 9753.300	10.128	40.590	50.718	-23.282	74.000	PEAK
5	12178.375	11.046	39.490	50.536	-23.464	74.000	PEAK

Note:

1. All readings above 1GHz are performed with peak and/or average measurements as necessary.
2. Peak measurements: RBW = 1MHz, VBW = 3 MHz, Sweep: Auto.
3. Average measurements: RBW = 1MHz, VBW = 10 Hz, Sweep: Auto.
4. “ \* ”, means this data is the worst emission level.
5. Measurement Level = Reading Level + Correct Factor.
6. The average measurement was not performed when the peak measured data under the limit of average detection.
7. The Emission above 18GHz were not included is because their levels are too low.

Site : CB1	Time : 2014/08/15 - 13:08
Limit : FCC_SpartC_15.247_H_03M_PK	Margin : 6
Probe : CB1_FCC_EFS_1-18G-1_0901 - VERTICAL	Power : AC 120V/60Hz
EUT : WIFI HD BABY CAM	Note : 802.11g_CH06

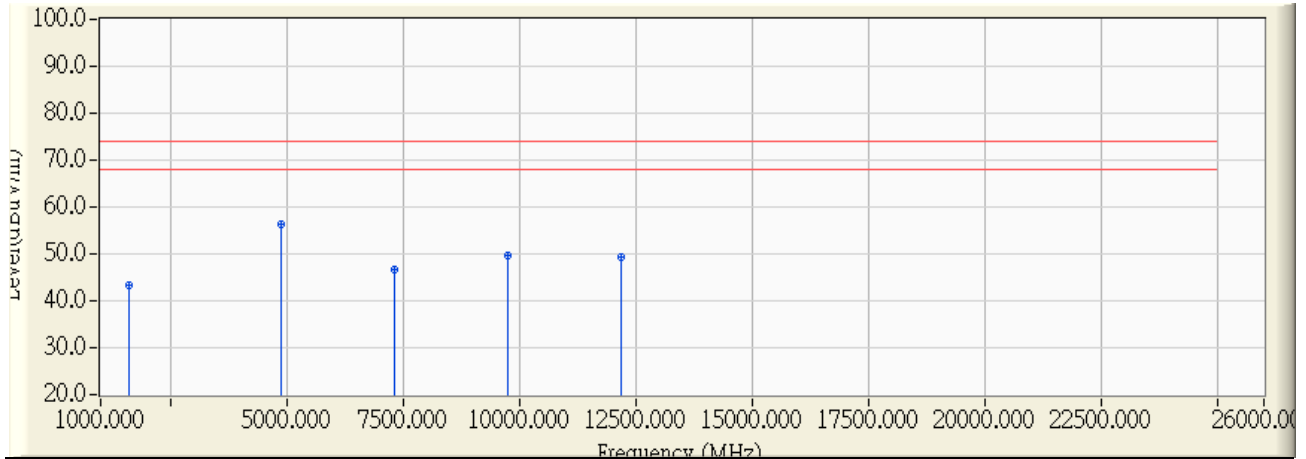

	Frequency (MHz)	Correct Factor (dB)	Reading Level (dBuV)	Measure Level (dBuV/m)	Margin (dB)	Limit (dBuV/m)	Detector Type
1	1600.000	-8.713	52.000	43.287	-30.713	74.000	PEAK
2	* 4878.100	-0.402	56.580	56.178	-17.822	74.000	PEAK
3	7310.000	5.679	41.140	46.819	-27.181	74.000	PEAK
4	9755.475	10.142	39.690	49.832	-24.168	74.000	PEAK
5	12191.125	11.040	38.330	49.370	-24.630	74.000	PEAK

**Note:**

1. All readings above 1GHz are performed with peak and/or average measurements as necessary.
2. Peak measurements: RBW = 1MHz, VBW = 3 MHz, Sweep: Auto.
3. Average measurements: RBW = 1MHz, VBW = 10 Hz, Sweep: Auto.
4. “ \* ”, means this data is the worst emission level.
5. Measurement Level = Reading Level + Correct Factor.
6. The average measurement was not performed when the peak measured data under the limit of average detection.
7. The Emission above 18GHz were not included is because their levels are too low.



Site : CB1	Time : 2014/08/15 - 13:09
Limit : FCC_SpartC_15.247_H_03M_AV	Margin : 6
Probe : CB1_FCC_EFS_1-18G-1_0901 - VERTICAL	Power : AC 120V/60Hz
EUT : WIFI HD BABY CAM	Note : 802.11g_CH06

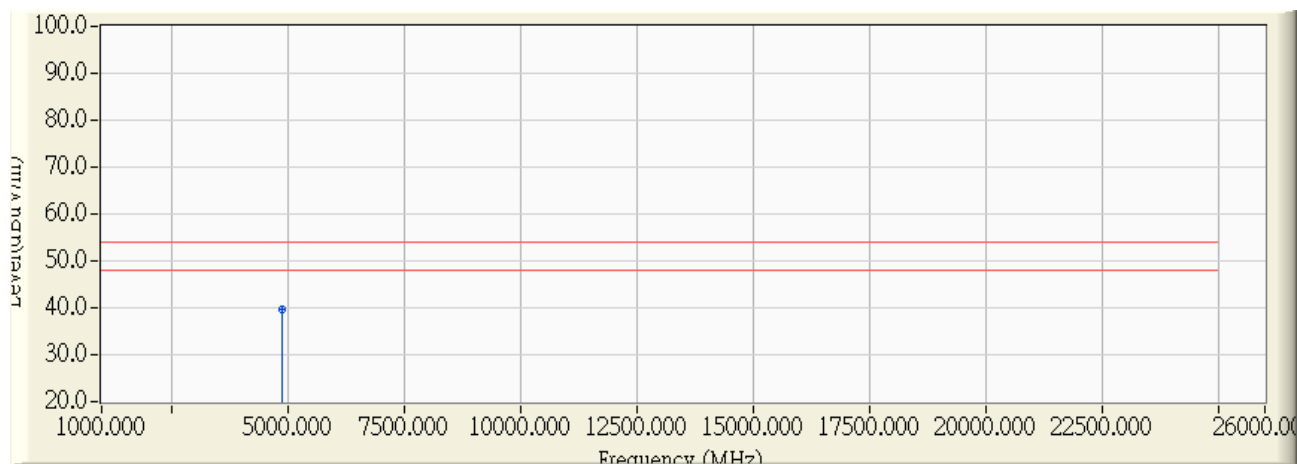

		Frequency (MHz)	Correct Factor (dB)	Reading Level (dBuV)	Measure Level (dBuV/m)	Margin (dB)	Limit (dBuV/m)	Detector Type
1	*	4873.850	-0.412	40.050	39.638	-14.362	54.000	AVERAGE

**Note:**

1. All readings above 1GHz are performed with peak and/or average measurements as necessary.
2. Peak measurements: RBW = 1MHz, VBW = 3 MHz, Sweep: Auto.
3. Average measurements: RBW = 1MHz, VBW = 10 Hz, Sweep: Auto.
4. “ \* ”, means this data is the worst emission level.
5. Measurement Level = Reading Level + Correct Factor.
6. The average measurement was not performed when the peak measured data under the limit of average detection.
7. The Emission above 18GHz were not included is because their levels are too low.

Site : CB1	Time : 2014/08/15 - 13:22
Limit : FCC_SpartC_15.247_H_03M_PK	Margin : 6
Probe : CB1_FCC_EFS_1-18G-1_0901 - HORIZONTAL	Power : AC 120V/60Hz
EUT : WIFI HD BABY CAM	Note : 802.11g_CH11

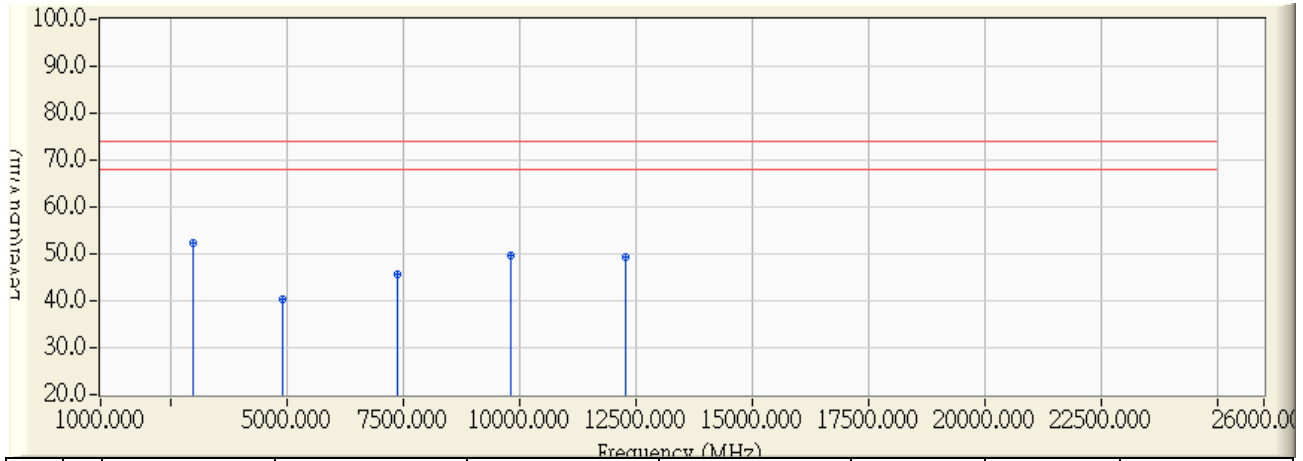

		Frequency (MHz)	Correct Factor (dB)	Reading Level (dBuV)	Measure Level (dBuV/m)	Margin (dB)	Limit (dBuV/m)	Detector Type
1	*	2990.500	-4.023	56.490	52.468	-21.532	74.000	PEAK
2		4922.475	-0.293	40.650	40.356	-33.644	74.000	PEAK
3		7365.450	5.799	39.830	45.629	-28.371	74.000	PEAK
4		9826.975	10.605	38.920	49.525	-24.475	74.000	PEAK
5		12294.925	10.993	38.440	49.433	-24.567	74.000	PEAK

Note:

1. All readings above 1GHz are performed with peak and/or average measurements as necessary.
2. Peak measurements: RBW = 1MHz, VBW = 3 MHz, Sweep: Auto.
3. Average measurements: RBW = 1MHz, VBW = 10 Hz, Sweep: Auto.
4. “ \* ”, means this data is the worst emission level.
5. Measurement Level = Reading Level + Correct Factor.
6. The average measurement was not performed when the peak measured data under the limit of average detection.
7. The Emission above 18GHz were not included is because their levels are too low.

Site : CB1	Time : 2014/08/15 - 13:30
Limit : FCC_SpartC_15.247_H_03M_PK	Margin : 6
Probe : CB1_FCC_EFS_1-18G-1_0901 - VERTICAL	Power : AC 120V/60Hz
EUT : WIFI HD BABY CAM	Note : 802.11g_CH11

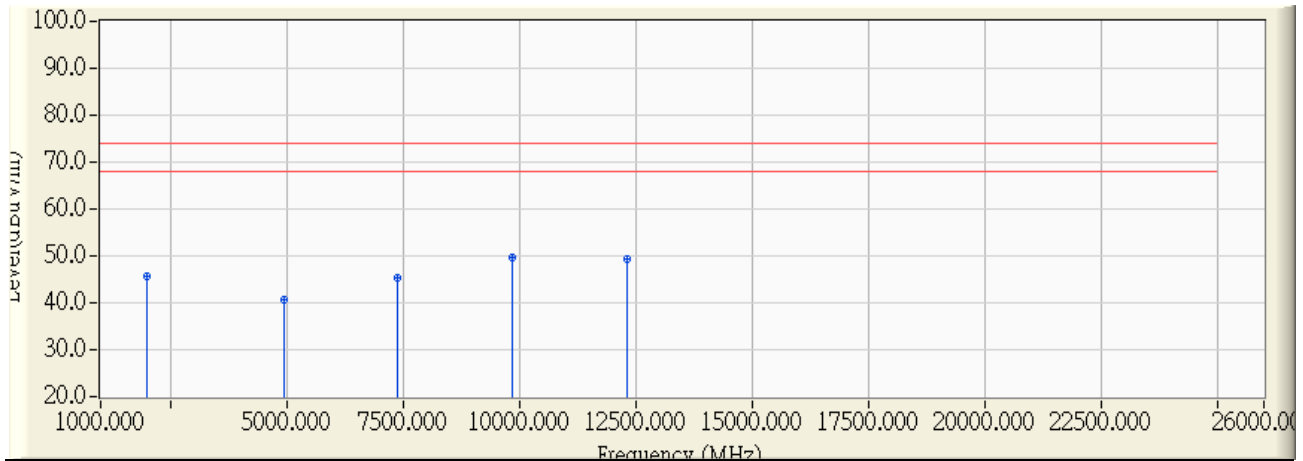

	Frequency (MHz)	Correct Factor (dB)	Reading Level (dBuV)	Measure Level (dBuV/m)	Margin (dB)	Limit (dBuV/m)	Detector Type
1	2000.000	-7.217	52.810	45.593	-28.407	74.000	PEAK
2	4927.650	-0.281	41.070	40.789	-33.211	74.000	PEAK
3	7367.075	5.802	39.460	45.262	-28.738	74.000	PEAK
4	* 9835.650	10.661	38.950	49.611	-24.389	74.000	PEAK
5	12310.825	10.985	38.460	49.445	-24.555	74.000	PEAK

Note:

1. All readings above 1GHz are performed with peak and/or average measurements as necessary.
2. Peak measurements: RBW = 1MHz, VBW = 3 MHz, Sweep: Auto.
3. Average measurements: RBW = 1MHz, VBW = 10 Hz, Sweep: Auto.
4. “ \* ”, means this data is the worst emission level.
5. Measurement Level = Reading Level + Correct Factor.
6. The average measurement was not performed when the peak measured data under the limit of average detection.
7. The Emission above 18GHz were not included is because their levels are too low.

Site : CB1	Time : 2014/08/15 - 13:43
Limit : FCC_SpartC_15.247_H_03M_PK	Margin : 6
Probe : CB1_FCC_EFS_1-18G-1_0901 - HORIZONTAL	Power : AC 120V/60Hz
EUT : WIFI HD BABY CAM	Note : 802.11n 20MHz_CH01

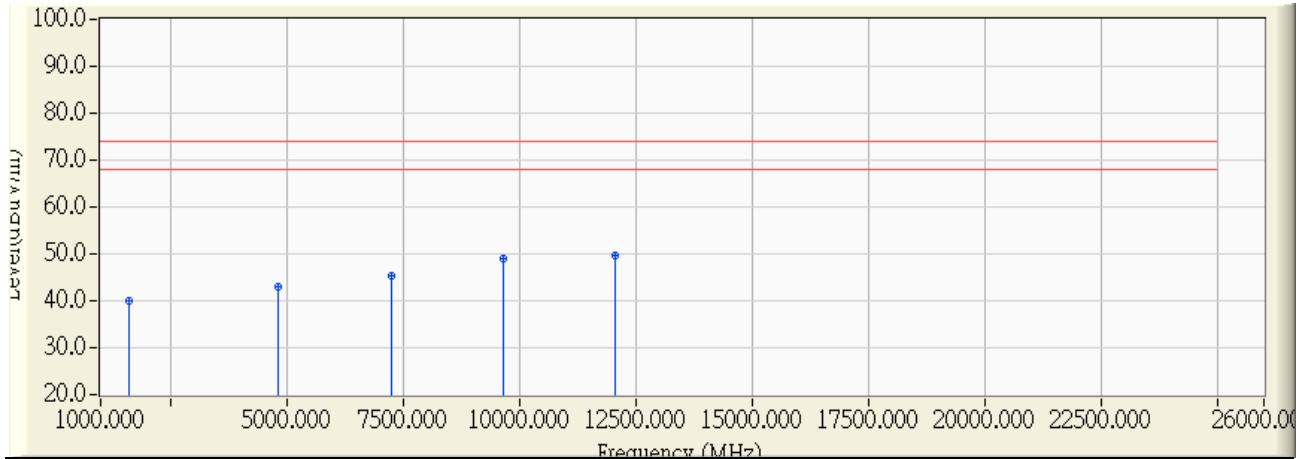

	Frequency (MHz)	Correct Factor (dB)	Reading Level (dBuV)	Measure Level (dBuV/m)	Margin (dB)	Limit (dBuV/m)	Detector Type
1	1600.000	-8.713	48.790	40.077	-33.923	74.000	PEAK
2	4826.825	-0.527	43.440	42.913	-31.087	74.000	PEAK
3	7259.700	5.569	39.760	45.330	-28.670	74.000	PEAK
4	9667.400	9.572	39.400	48.972	-25.028	74.000	PEAK
5	* 12057.100	11.101	38.420	49.521	-24.479	74.000	PEAK

**Note:**

1. All readings above 1GHz are performed with peak and/or average measurements as necessary.
2. Peak measurements: RBW = 1MHz, VBW = 3 MHz, Sweep: Auto.
3. Average measurements: RBW = 1MHz, VBW = 10 Hz, Sweep: Auto.
4. “ \* ”, means this data is the worst emission level.
5. Measurement Level = Reading Level + Correct Factor.
6. The average measurement was not performed when the peak measured data under the limit of average detection.
7. The Emission above 18GHz were not included is because their levels are too low.

Site : CB1	Time : 2014/08/16 - 09:55
Limit : FCC_SpartC_15.247_H_03M_PK	Margin : 6
Probe : CB1_FCC_EFS_1-18G-1_0901 - VERTICAL	Power : AC 120V/60Hz
EUT : WIFI HD BABY CAM	Note : 802.11n 20MHz_CH01

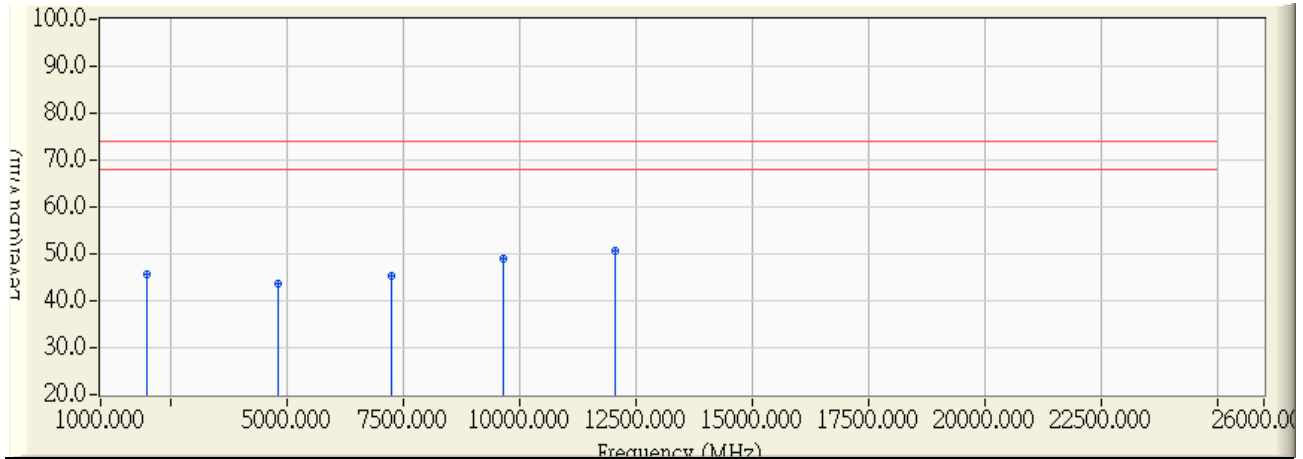

	Frequency (MHz)	Correct Factor (dB)	Reading Level (dBuV)	Measure Level (dBuV/m)	Margin (dB)	Limit (dBuV/m)	Detector Type
1	2000.000	-7.217	53.000	45.783	-28.217	74.000	PEAK
2	4824.400	-0.532	44.120	43.587	-30.413	74.000	PEAK
3	7240.330	5.528	39.870	45.398	-28.602	74.000	PEAK
4	9651.200	9.466	39.370	48.837	-25.163	74.000	PEAK
5	* 12051.130	11.104	39.400	50.504	-23.496	74.000	PEAK

**Note:**

1. All readings above 1GHz are performed with peak and/or average measurements as necessary.
2. Peak measurements: RBW = 1MHz, VBW = 3 MHz, Sweep: Auto.
3. Average measurements: RBW = 1MHz, VBW = 10 Hz, Sweep: Auto.
4. “ \* ”, means this data is the worst emission level.
5. Measurement Level = Reading Level + Correct Factor.
6. The average measurement was not performed when the peak measured data under the limit of average detection.
7. The Emission above 18GHz were not included is because their levels are too low.

Site : CB1	Time : 2014/08/16 - 10:03
Limit : FCC_SpartC_15.247_H_03M_PK	Margin : 6
Probe : CB1_FCC_EFS_1-18G-1_0901 - HORIZONTAL	Power : AC 120V/60Hz
EUT : WIFI HD BABY CAM	Note : 802.11n 20MHz_CH06

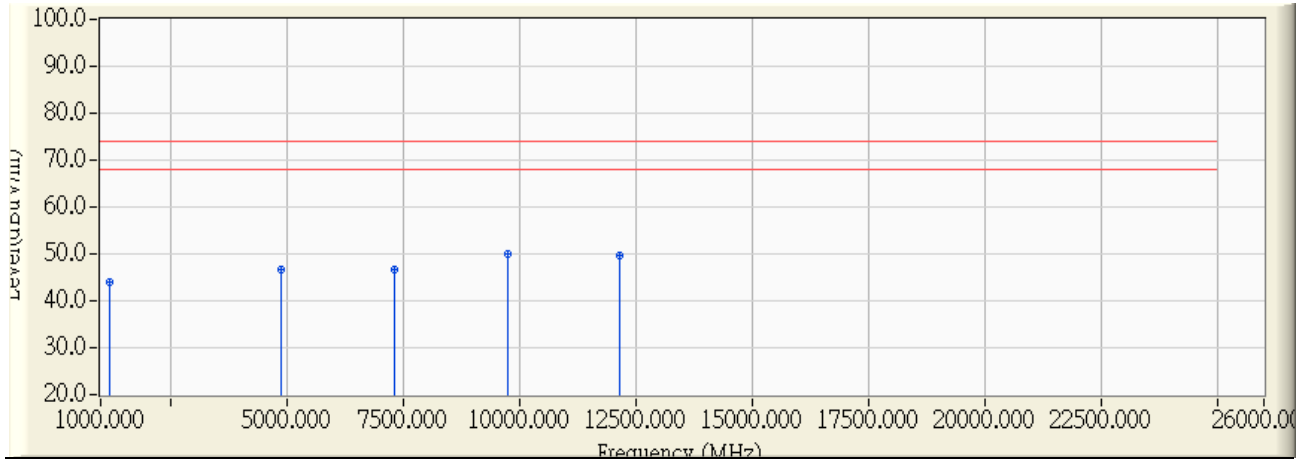

	Frequency (MHz)	Correct Factor (dB)	Reading Level (dBuV)	Measure Level (dBuV/m)	Margin (dB)	Limit (dBuV/m)	Detector Type
1	1200.000	-10.500	54.570	44.071	-29.929	74.000	PEAK
2	4877.080	-0.404	47.090	46.686	-27.314	74.000	PEAK
3	7308.250	5.675	40.990	46.665	-27.335	74.000	PEAK
4	* 9754.830	10.138	39.710	49.848	-24.152	74.000	PEAK
5	12160.580	11.055	38.610	49.664	-24.336	74.000	PEAK

**Note:**

1. All readings above 1GHz are performed with peak and/or average measurements as necessary.
2. Peak measurements: RBW = 1MHz, VBW = 3 MHz, Sweep: Auto.
3. Average measurements: RBW = 1MHz, VBW = 10 Hz, Sweep: Auto.
4. “ \* ”, means this data is the worst emission level.
5. Measurement Level = Reading Level + Correct Factor.
6. The average measurement was not performed when the peak measured data under the limit of average detection.
7. The Emission above 18GHz were not included is because their levels are too low.

Site : CB1	Time : 2014/08/16 - 10:11
Limit : FCC_SpartC_15.247_H_03M_PK	Margin : 6
Probe : CB1_FCC_EFS_1-18G-1_0901 - VERTICAL	Power : AC 120V/60Hz
EUT : WIFI HD BABY CAM	Note : 802.11n 20MHz_CH06

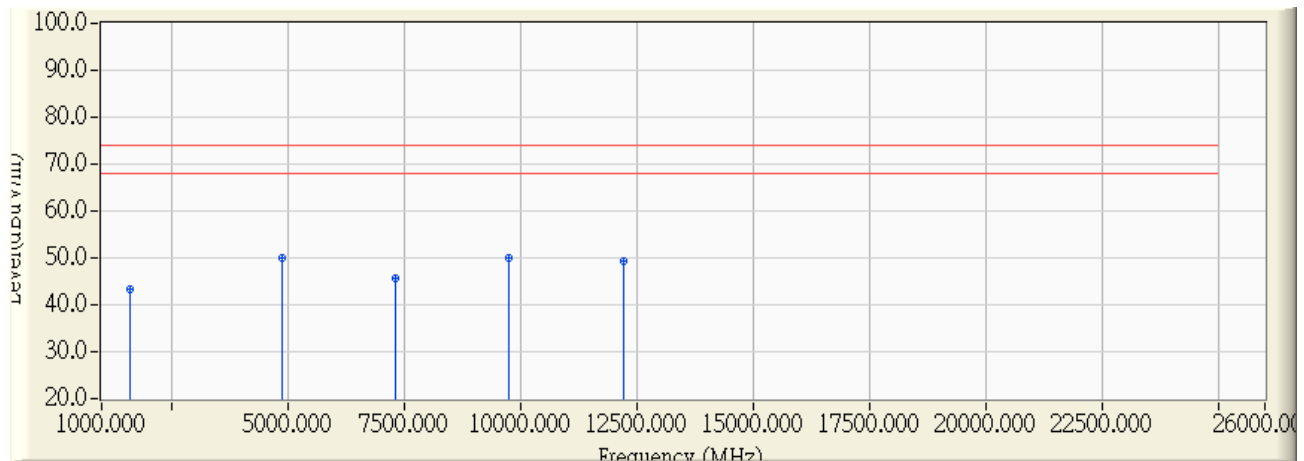

	Frequency (MHz)	Correct Factor (dB)	Reading Level (dBuV)	Measure Level (dBuV/m)	Margin (dB)	Limit (dBuV/m)	Detector Type
1	1600.000	-8.713	52.090	43.377	-30.623	74.000	PEAK
2	* 4877.000	-0.404	50.250	49.846	-24.154	74.000	PEAK
3	7307.420	5.674	40.020	45.693	-28.307	74.000	PEAK
4	9762.750	10.190	39.650	49.839	-24.161	74.000	PEAK
5	12206.830	11.033	38.290	49.323	-24.677	74.000	PEAK

**Note:**

1. All readings above 1GHz are performed with peak and/or average measurements as necessary.
2. Peak measurements: RBW = 1MHz, VBW = 3 MHz, Sweep: Auto.
3. Average measurements: RBW = 1MHz, VBW = 10 Hz, Sweep: Auto.
4. “ \* ”, means this data is the worst emission level.
5. Measurement Level = Reading Level + Correct Factor.
6. The average measurement was not performed when the peak measured data under the limit of average detection.
7. The Emission above 18GHz were not included is because their levels are too low.

Site : CB1	Time : 2014/08/16 - 10:20
Limit : FCC_SpartC_15.247_H_03M_PK	Margin : 6
Probe : CB1_FCC_EFS_1-18G-1_0901 - HORIZONTAL	Power : AC 120V/60Hz
EUT : WIFI HD BABY CAM	Note : 802.11n 20MHz_CH11

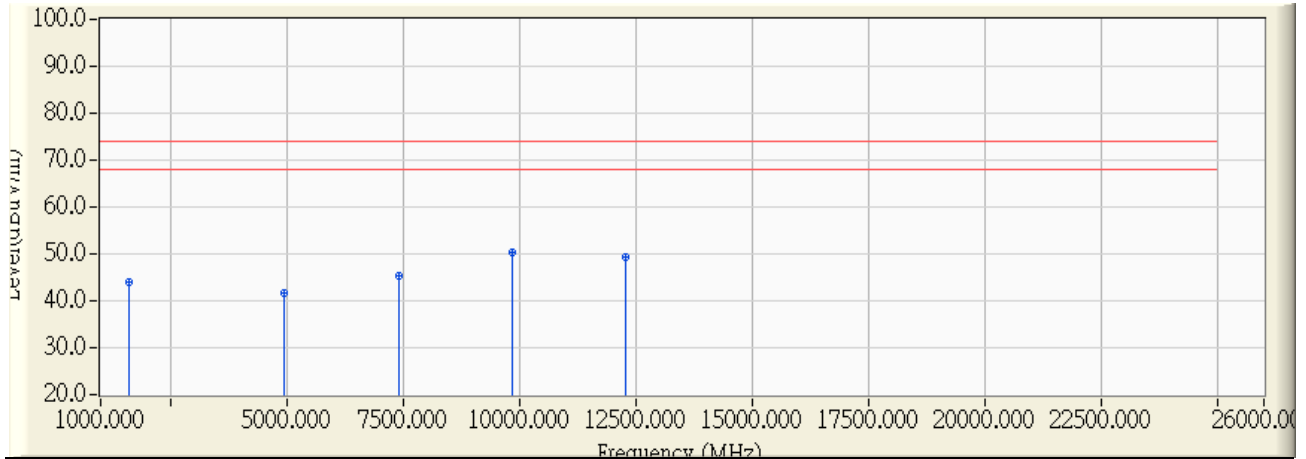

	Frequency (MHz)	Correct Factor (dB)	Reading Level (dBuV)	Measure Level (dBuV/m)	Margin (dB)	Limit (dBuV/m)	Detector Type
1	1600.000	-8.713	52.560	43.847	-30.153	74.000	PEAK
2	4926.500	-0.284	41.850	41.566	-32.434	74.000	PEAK
3	7399.500	5.872	39.480	45.353	-28.647	74.000	PEAK
4	* 9839.330	10.684	39.620	50.305	-23.695	74.000	PEAK
5	12292.670	10.994	38.370	49.364	-24.636	74.000	PEAK

**Note:**

1. All readings above 1GHz are performed with peak and/or average measurements as necessary.
2. Peak measurements: RBW = 1MHz, VBW = 3 MHz, Sweep: Auto.
3. Average measurements: RBW = 1MHz, VBW = 10 Hz, Sweep: Auto.
4. “ \* ”, means this data is the worst emission level.
5. Measurement Level = Reading Level + Correct Factor.
6. The average measurement was not performed when the peak measured data under the limit of average detection.
7. The Emission above 18GHz were not included is because their levels are too low.



Site : CB1	Time : 2014/08/16 - 10:27
Limit : FCC_SpartC_15.247_H_03M_PK	Margin : 6
Probe : CB1_FCC_EFS_1-18G-1_0901 - VERTICAL	Power : AC 120V/60Hz
EUT : WIFI HD BABY CAM	Note : 802.11n 20MHz_CH11

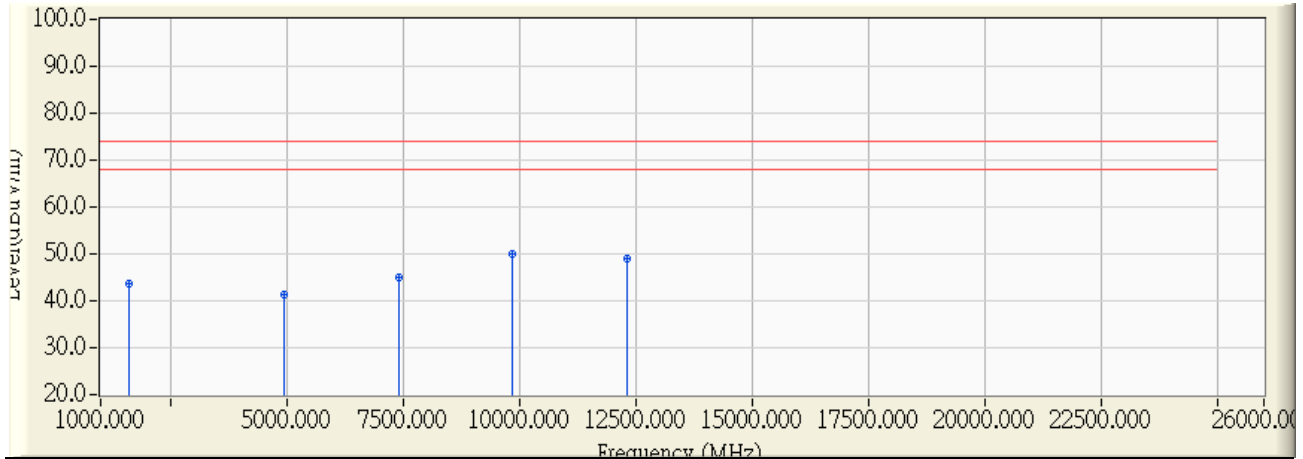

	Frequency (MHz)	Correct Factor (dB)	Reading Level (dBuV)	Measure Level (dBuV/m)	Margin (dB)	Limit (dBuV/m)	Detector Type
1	1600.000	-8.713	52.270	43.557	-30.443	74.000	PEAK
2	4929.750	-0.275	41.500	41.224	-32.776	74.000	PEAK
3	7398.330	5.871	39.270	45.140	-28.860	74.000	PEAK
4	* 9834.830	10.656	39.270	49.926	-24.074	74.000	PEAK
5	12306.580	10.987	38.060	49.047	-24.953	74.000	PEAK

Note:

1. All readings above 1GHz are performed with peak and/or average measurements as necessary.
2. Peak measurements: RBW = 1MHz, VBW = 3 MHz, Sweep: Auto.
3. Average measurements: RBW = 1MHz, VBW = 10 Hz, Sweep: Auto.
4. “ \* ”, means this data is the worst emission level.
5. Measurement Level = Reading Level + Correct Factor.
6. The average measurement was not performed when the peak measured data under the limit of average detection.
7. The Emission above 18GHz were not included is because their levels are too low.

**5. RF antenna conducted test**

**5.1. Test Equipment**

The following test equipments are used during the test:

**RF antenna conducted test / SR7**

Instrument	Manufacturer	Model No.	Serial No	Next Cal. Date
Spectrum Analyzer	Agilent	N9010A-EXA	US47140172	2015/07/14

Note: 1. All equipments that need to calibrate are with calibration period of 1 year.

**5.2. Test Setup**

RF Antenna Conducted Measurement:

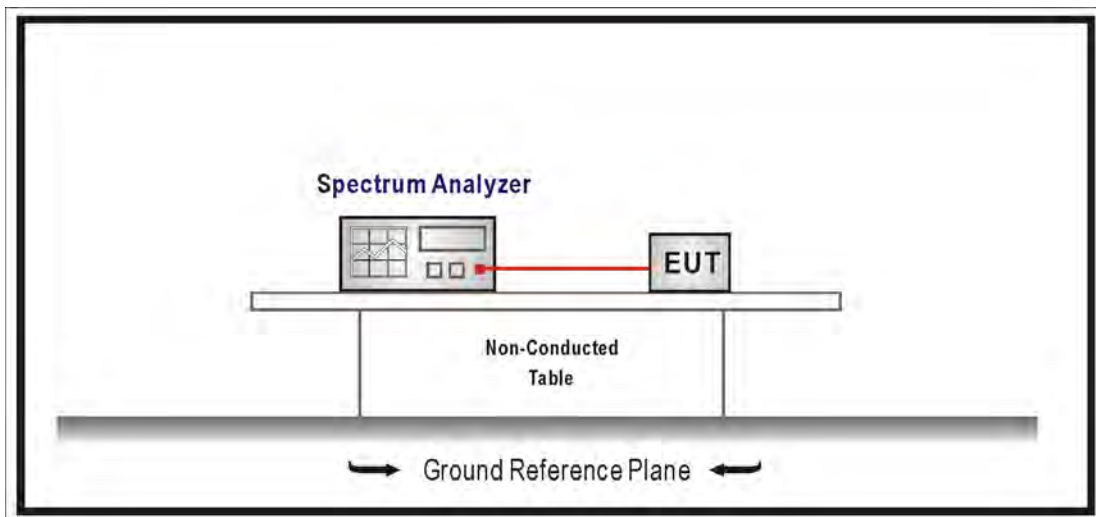

### 5.3. Limits

In any 100 kHz bandwidth outside the frequency band in which the spread spectrum or digitally modulated intentional radiator is operating, the radio frequency power that is produced by the intentional radiator shall be at least 20 dB below that in the 100 kHz bandwidth within the band that contains the highest level of the desired power, based on either an RF conducted or a radiated measurement, provided the transmitter demonstrates compliance with the peak conducted power limits. If the transmitter complies with the conducted power limits based on the use of RMS averaging over a time interval, as permitted under paragraph of this section, the attenuation required under this paragraph shall be 30 dB instead of 20 dB. Attenuation below the general limits specified in § 15.209(a) is not required. In addition, radiated emissions which fall in the restricted bands, as defined in § 15.205(a), must also comply with the radiated emission limits specified in § 15.209(a) (see § 15.205(c)).

### 5.4. Test Procedure

The EUT was setup according to ANSI C63.4: 2009 and tested according to DTS test procedure section 11.0 of KDB558074 v03r02 for compliance to FCC 47CFR 15.247 requirements. Set RBW = 100 kHz, Set VBW > RBW, scan up through 10th harmonic.

### 5.5. Test Specification

According to FCC Part 15 Subpart C Paragraph 15.247: 2013

### 5.6. Uncertainty

Conducted is defined as  $\pm 1.27$ dB

## 5.7. Test Result

Product	WiFi HD Baby Cam		
Test Item	RF antenna conducted test		
Test Mode	Mode 1: Transmit		
Date of Test	2014/08/23	Test Site	SR7

IEEE 802.11b, ANT 0				
Channel No.	Frequency (MHz)	Measure Level (dBc)	Limit (dBc)	Result
1	2412	53.332	≥ 30	Pass
6	2437	63.151	≥ 30	Pass
11	2462	60.076	≥ 30	Pass

### Channel 01 (2412MHz)

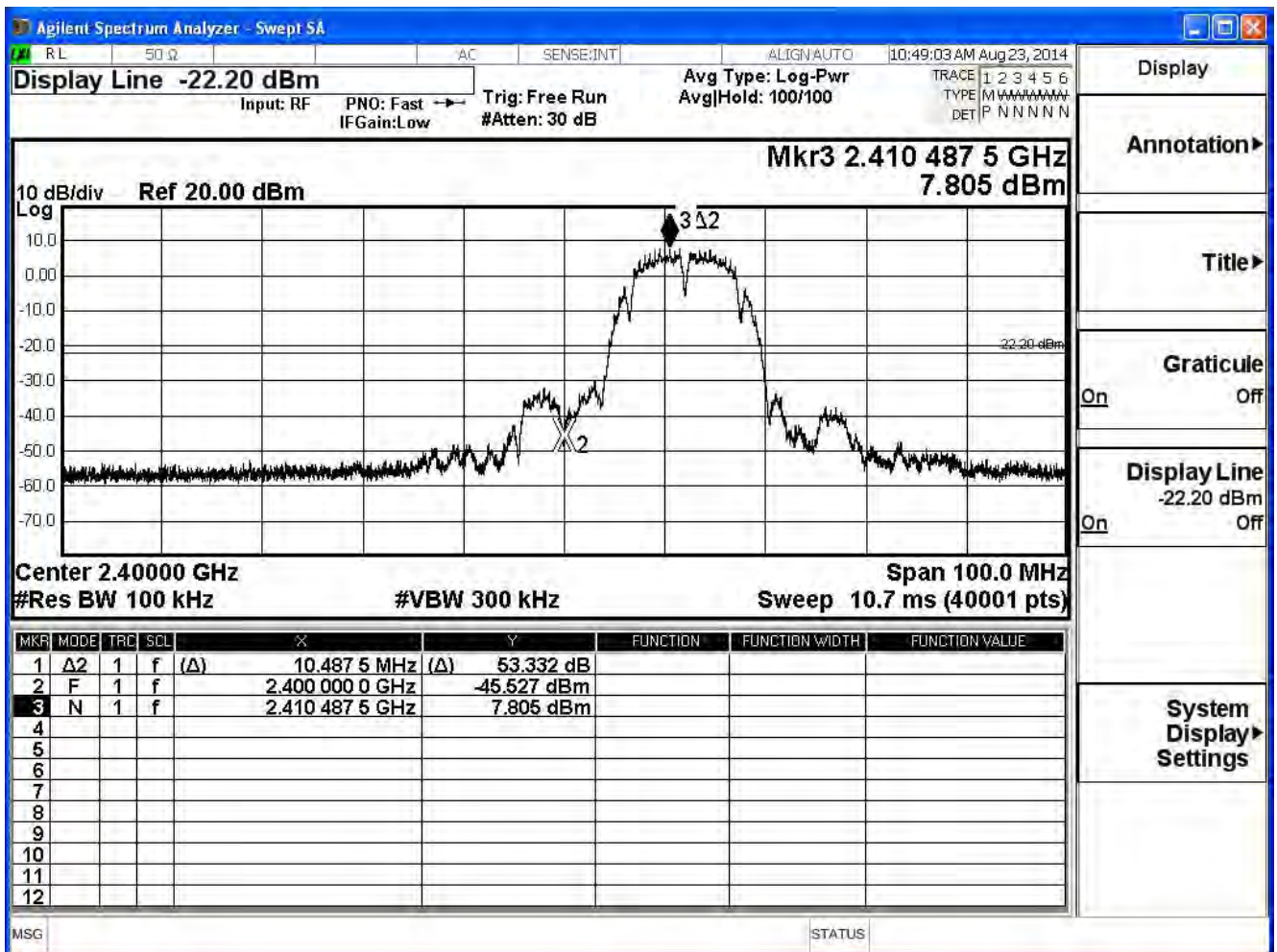

Channel 6 (2437MHz)

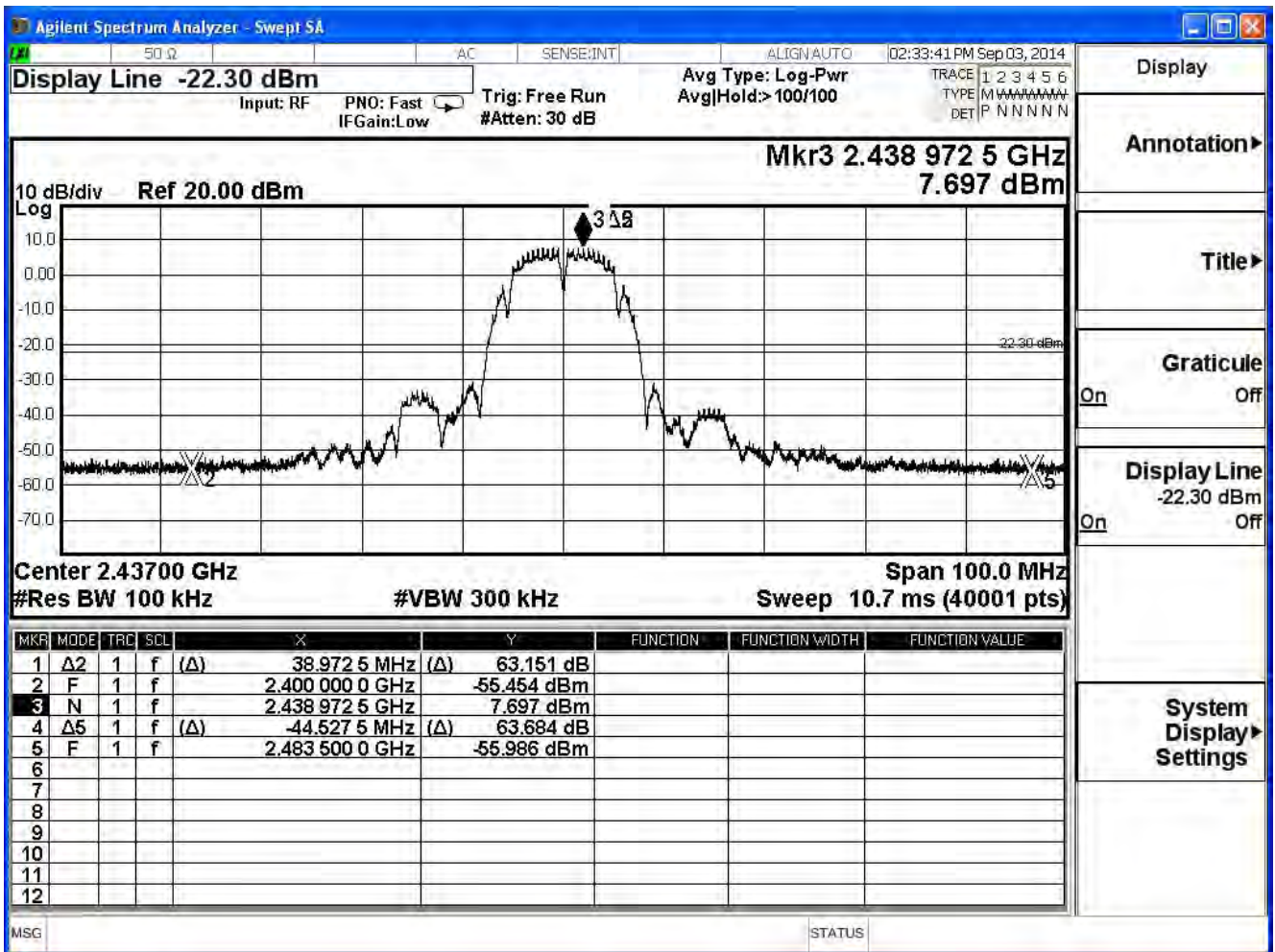

## Channel 11 (2462MHz)

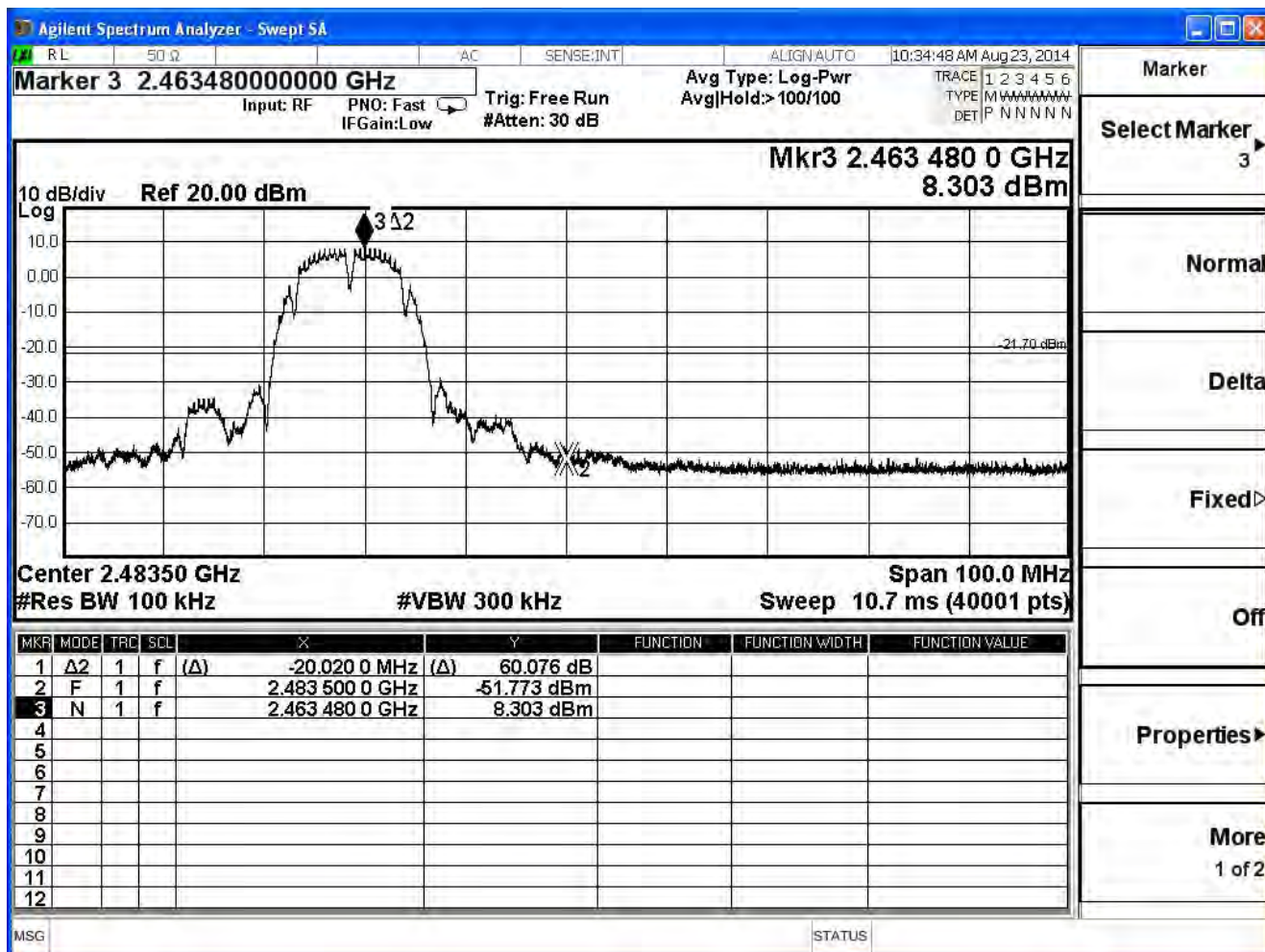

Product	WiFi HD Baby Cam		
Test Item	RF antenna conducted test		
Test Mode	Mode 1: Transmit		
Date of Test	2014/08/23	Test Site	SR7

IEEE 802.11g, ANT 0				
Channel No.	Frequency (MHz)	Measure Level (dBc)	Limit (dBc)	Result
1	2412	41.534	≥ 30	Pass
6	2437	52.138	≥ 30	Pass
11	2462	54.838	≥ 30	Pass

### Channel 01 (2412MHz)

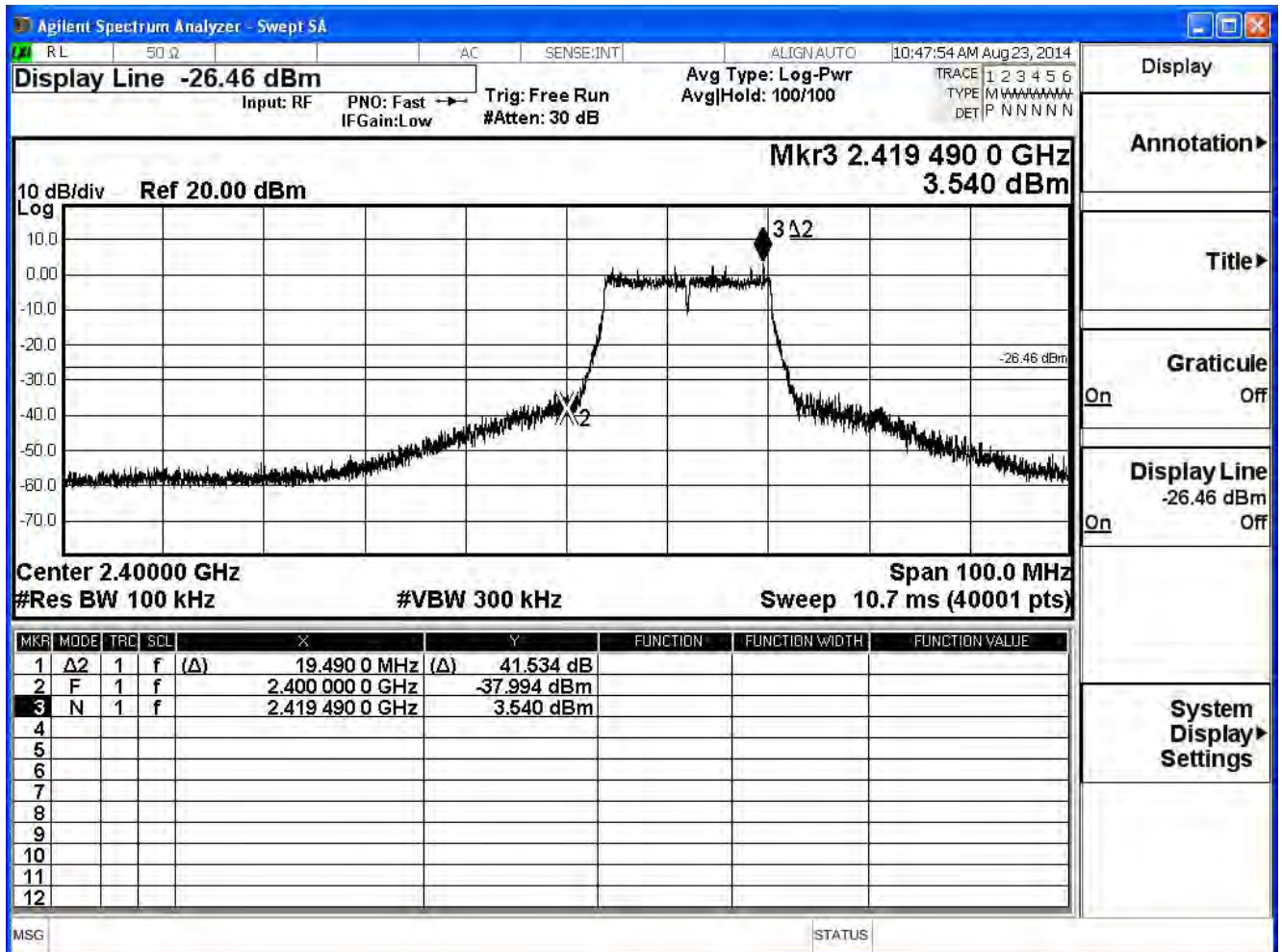

## Channel 6 (2437MHz)

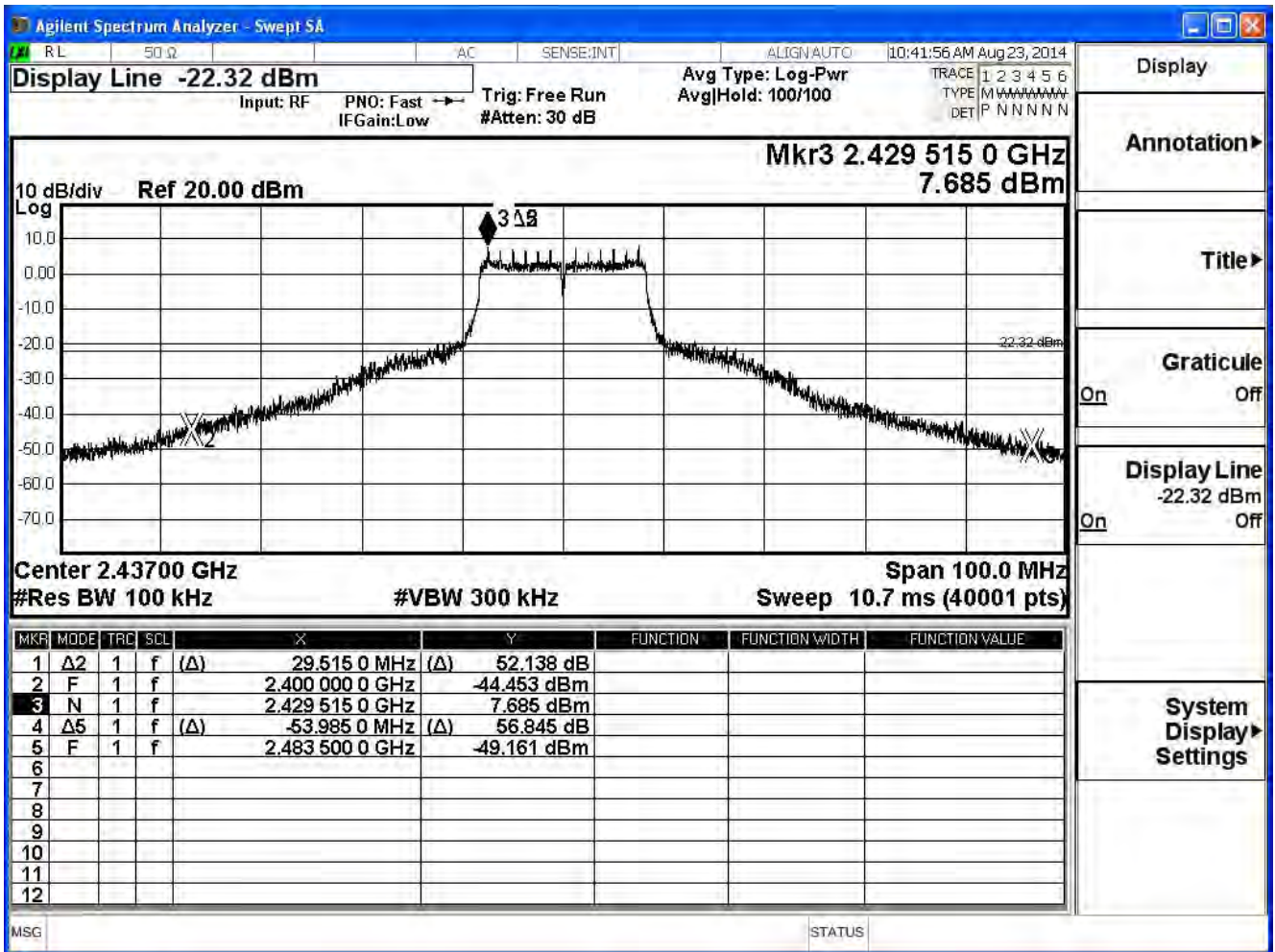



## Channel 11 (2462MHz)

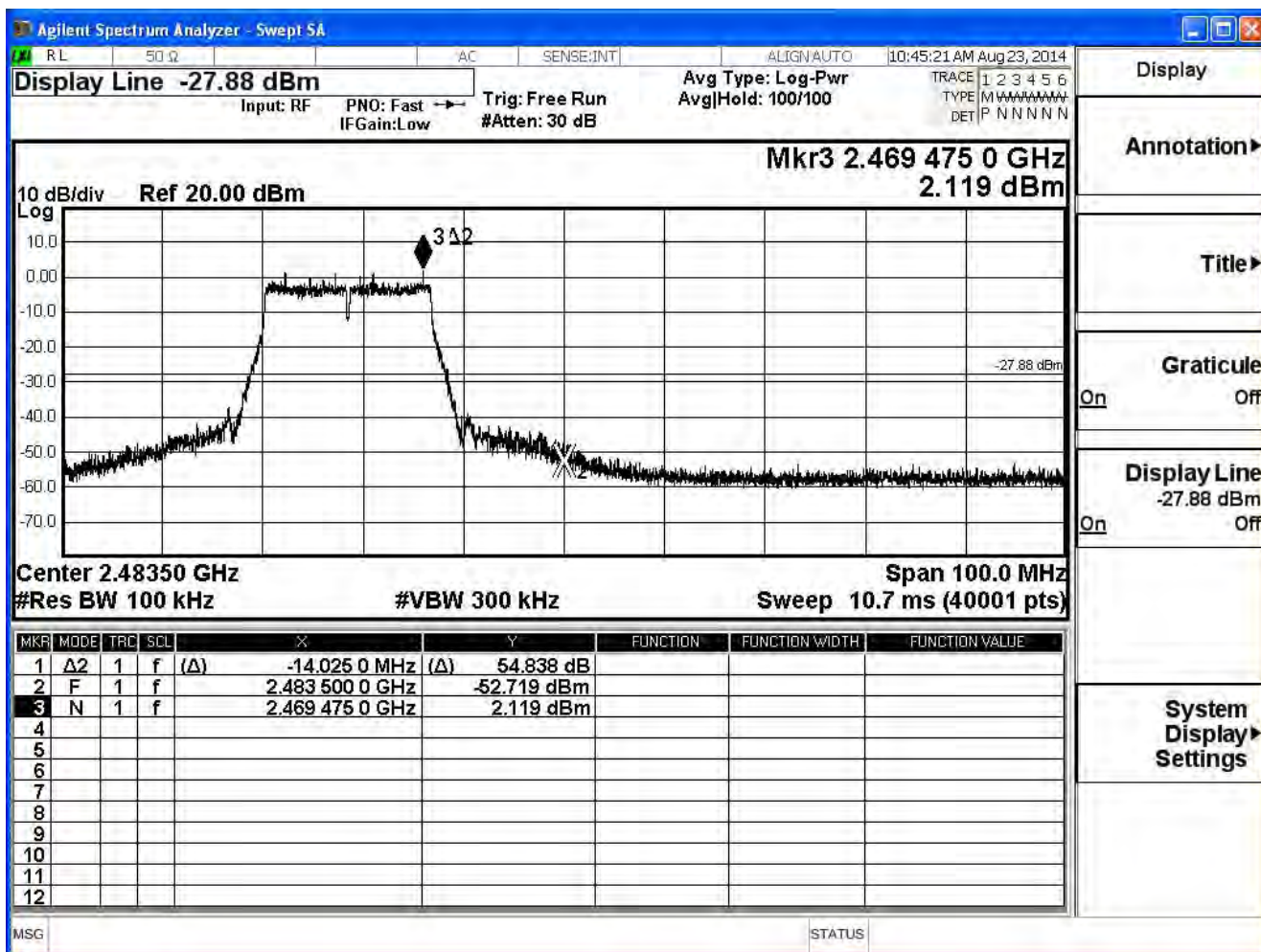

Product	WiFi HD Baby Cam		
Test Item	RF antenna conducted test		
Test Mode	Mode 1: Transmit		
Date of Test	2014/08/23	Test Site	SR7

IEEE 802.11n (20MHz), ANT 0				
Channel No.	Frequency (MHz)	Measure Level (dBc)	Limit (dBc)	Result
1	2412	41.187	$\geq 30$	Pass
6	2437	56.035	$\geq 30$	Pass
11	2462	50.667	$\geq 30$	Pass

### Channel 1 (2412MHz)

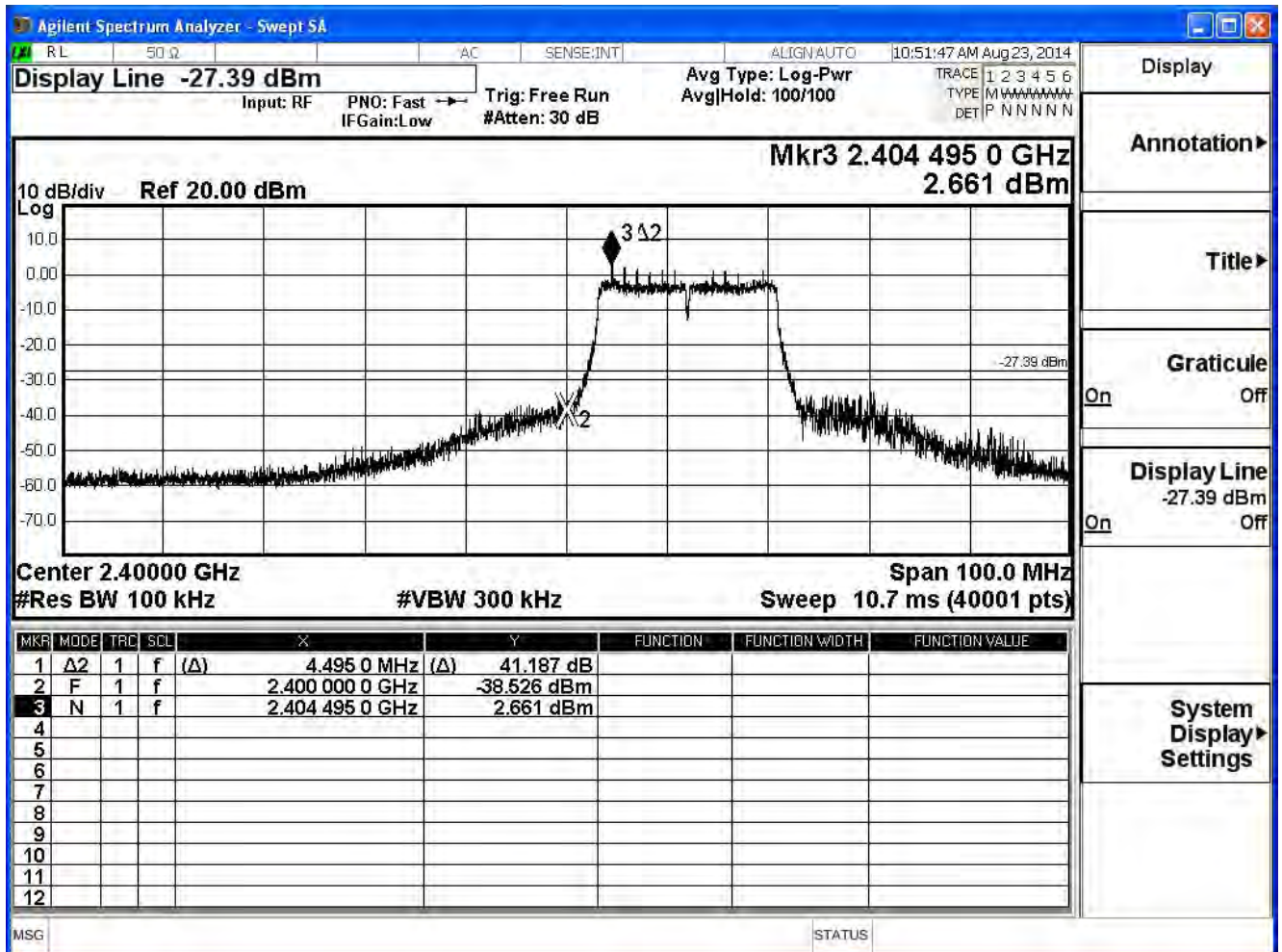

Channel 6 (2437MHz)

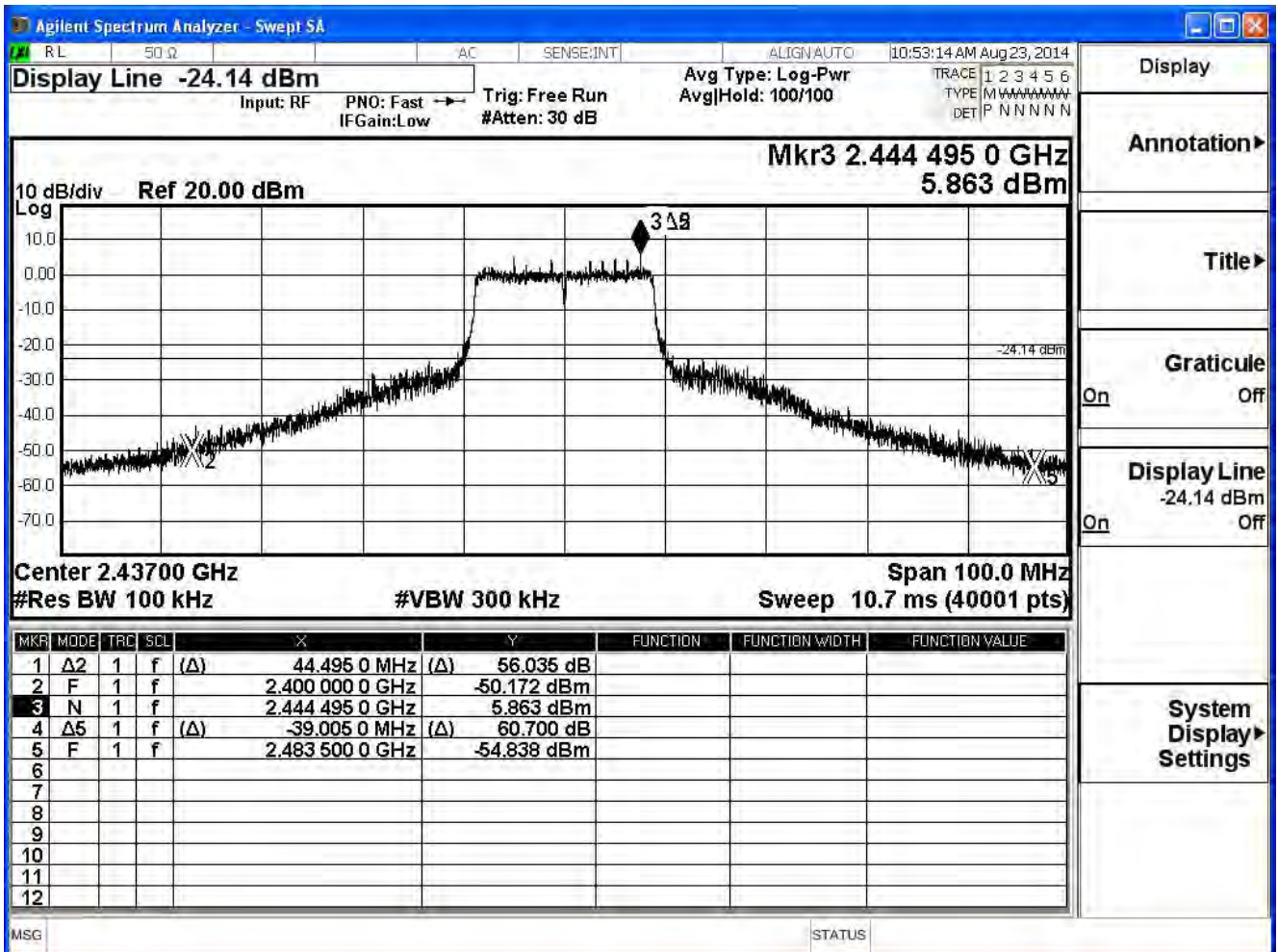

## Channel 11 (2462MHz)

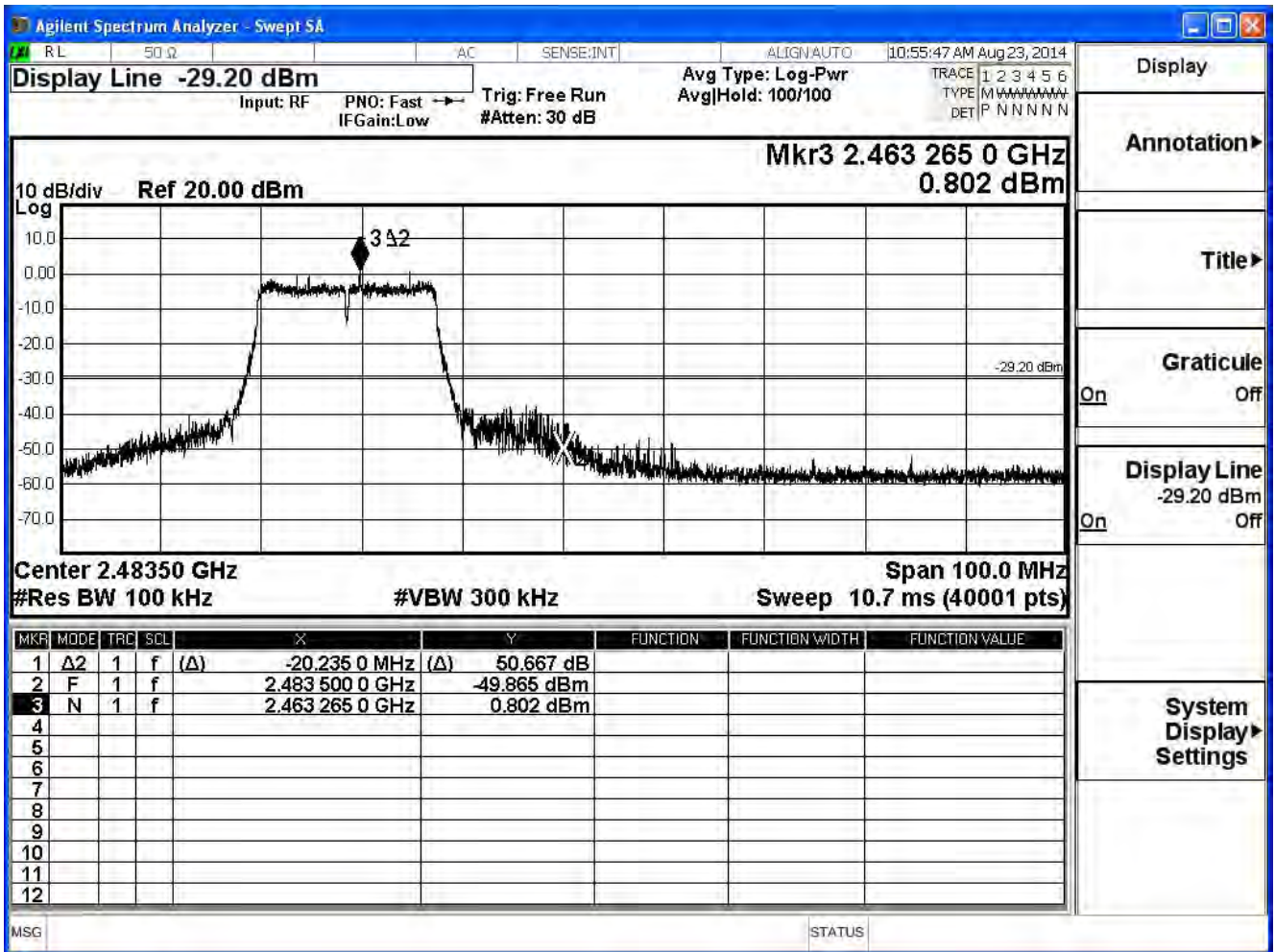

2412MHz (30MHz-1GHz)-802.11b

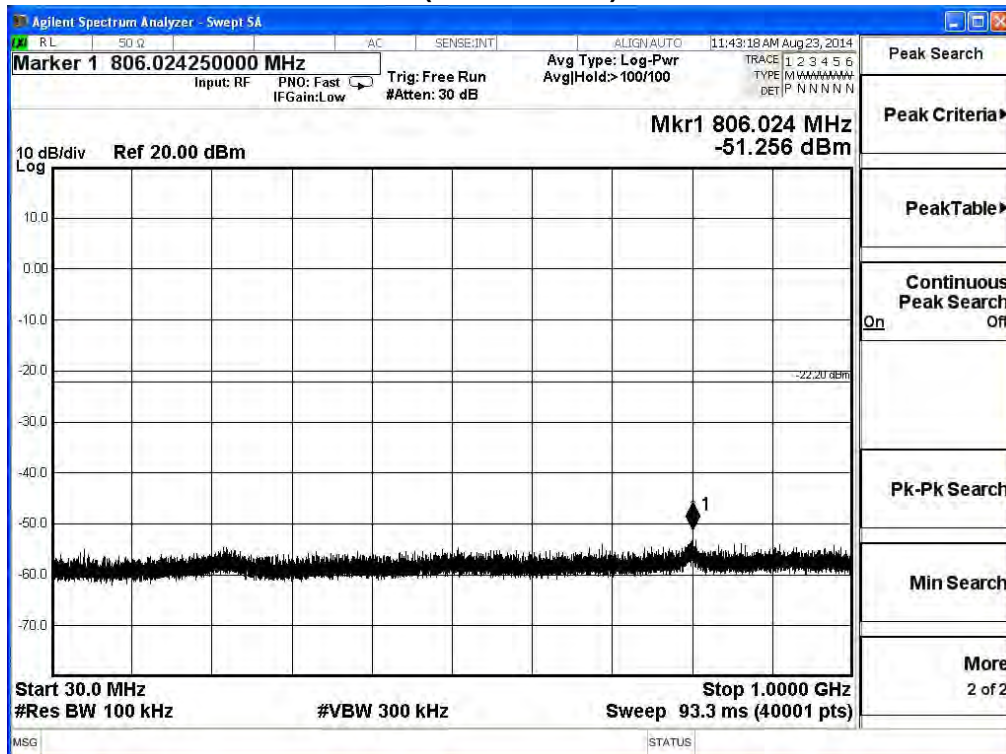

2412MHz (1GHz-8GHz) -802.11b

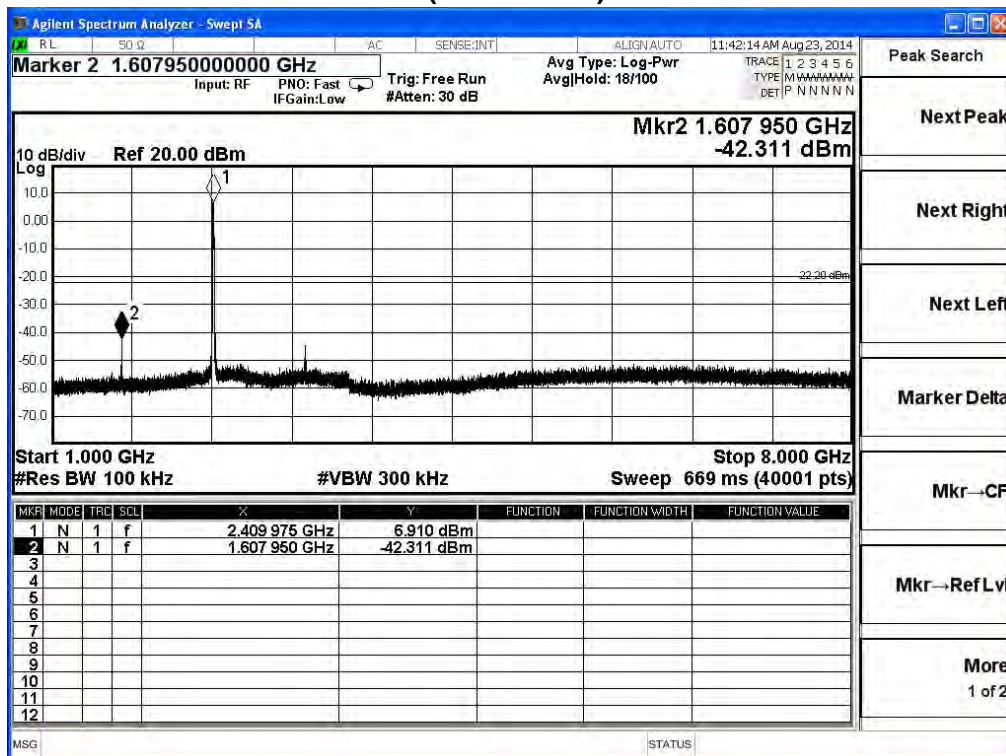

2412MHz (8GHz-16GHz) -802.11b

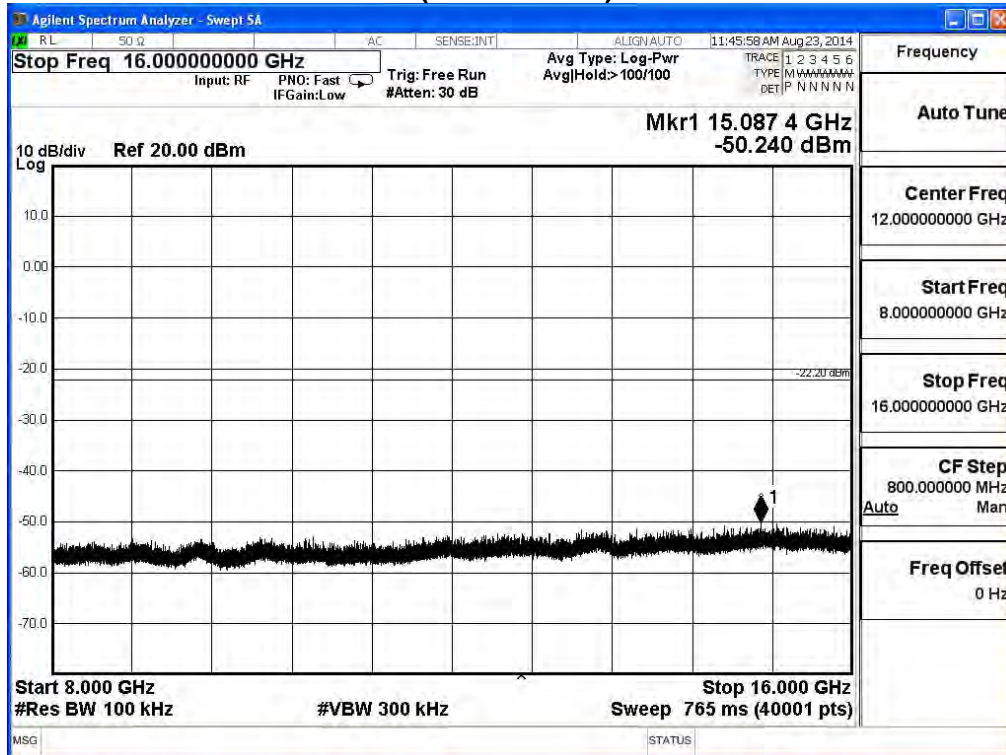

2412MHz (16GHz-25GHz) -802.11b

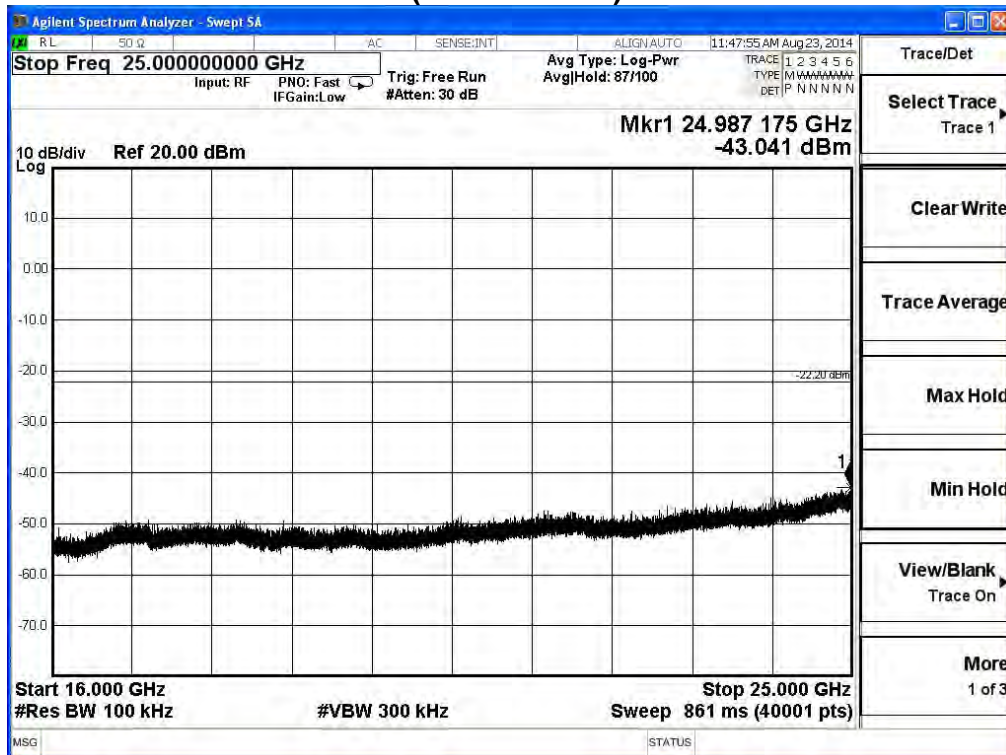

2437MHz (30MHz-1GHz)-802.11b

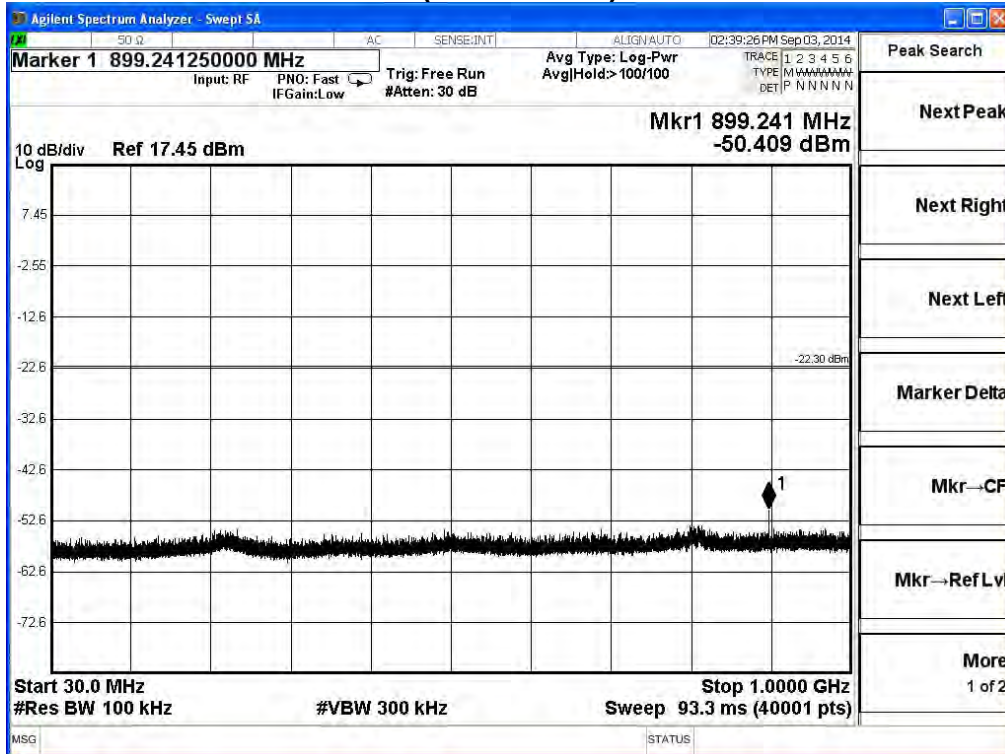

2437MHz (1GHz-8GHz) -802.11b

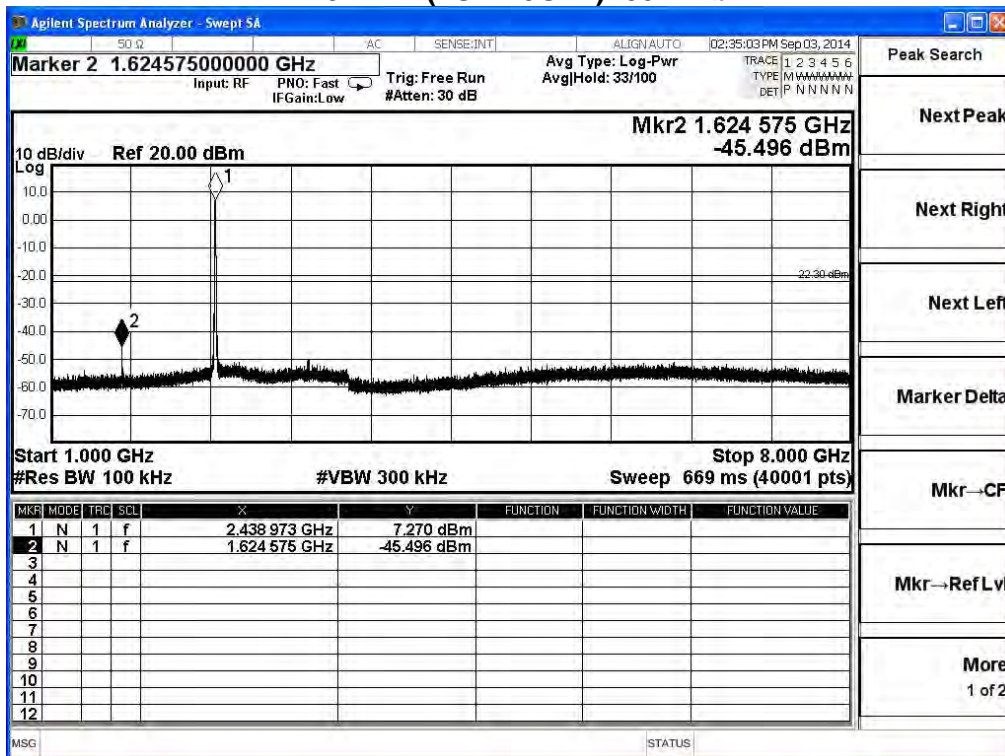

2437MHz (8GHz-16GHz) -802.11b

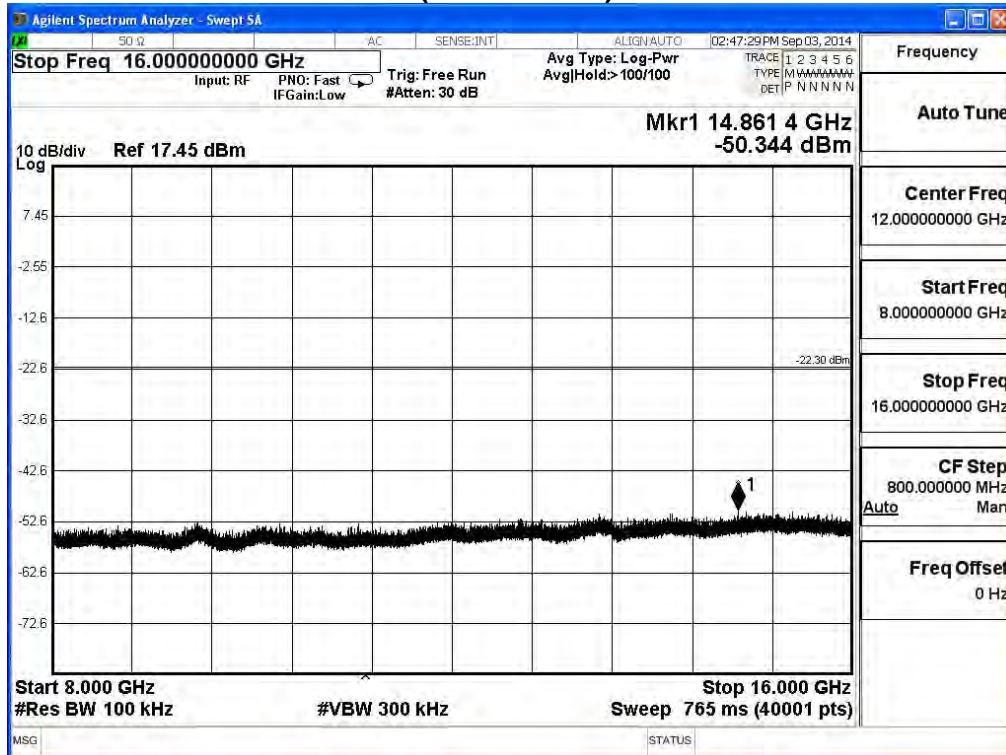

2437MHz (16GHz-25GHz) -802.11b

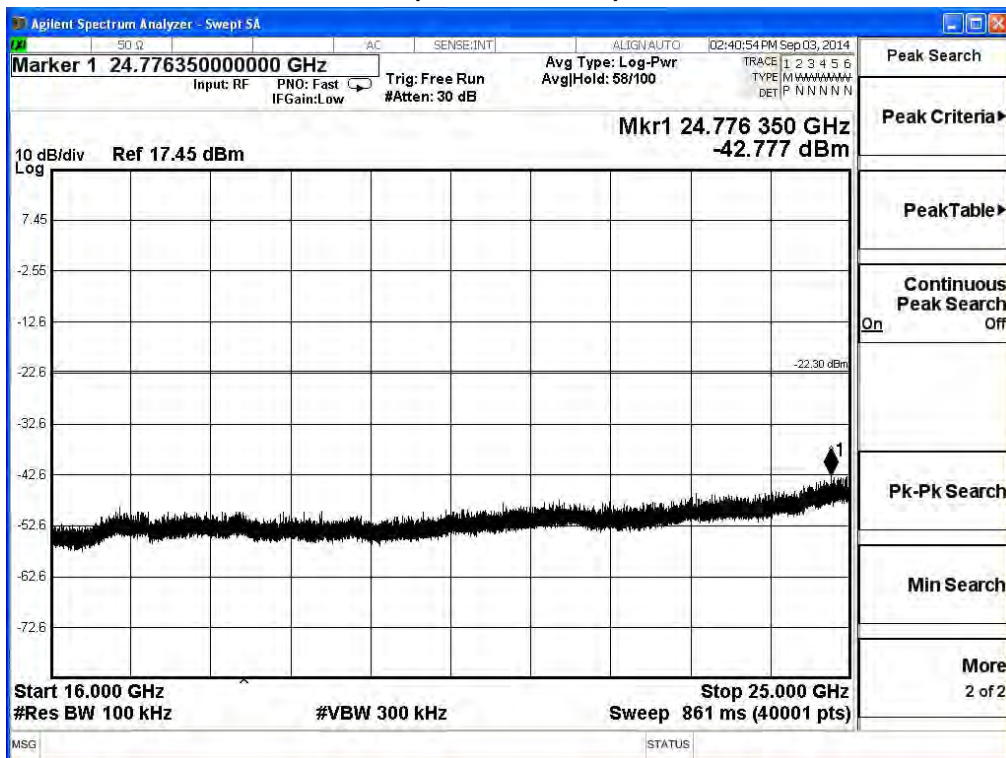



2462MHz (30MHz-1GHz)-802.11b

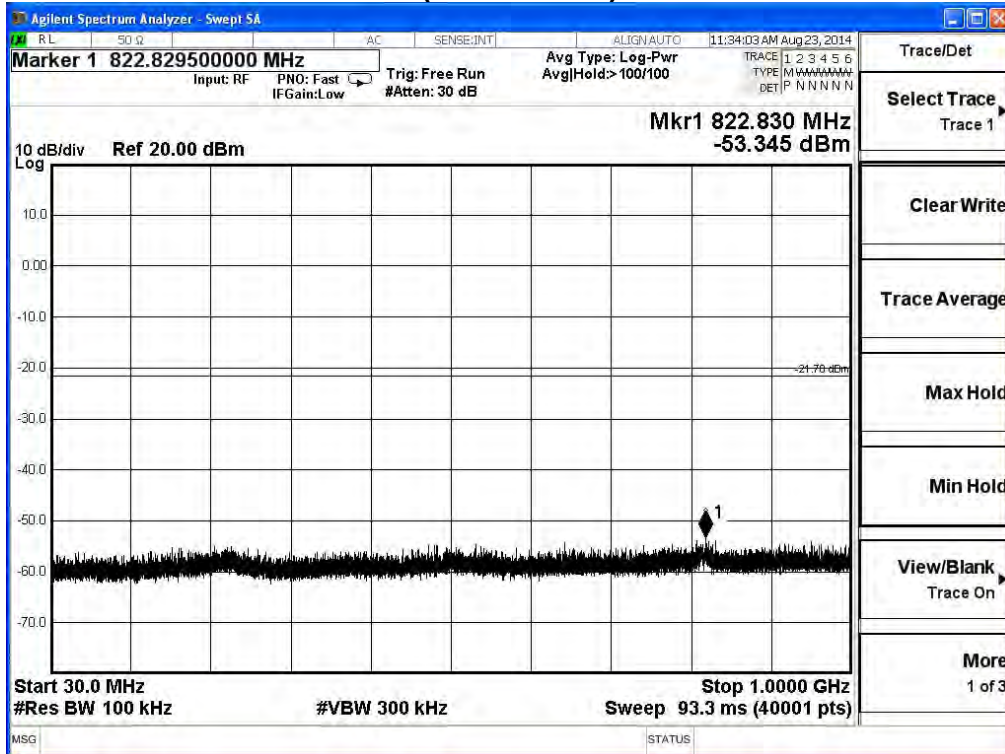

2462MHz (1GHz-8GHz) -802.11b

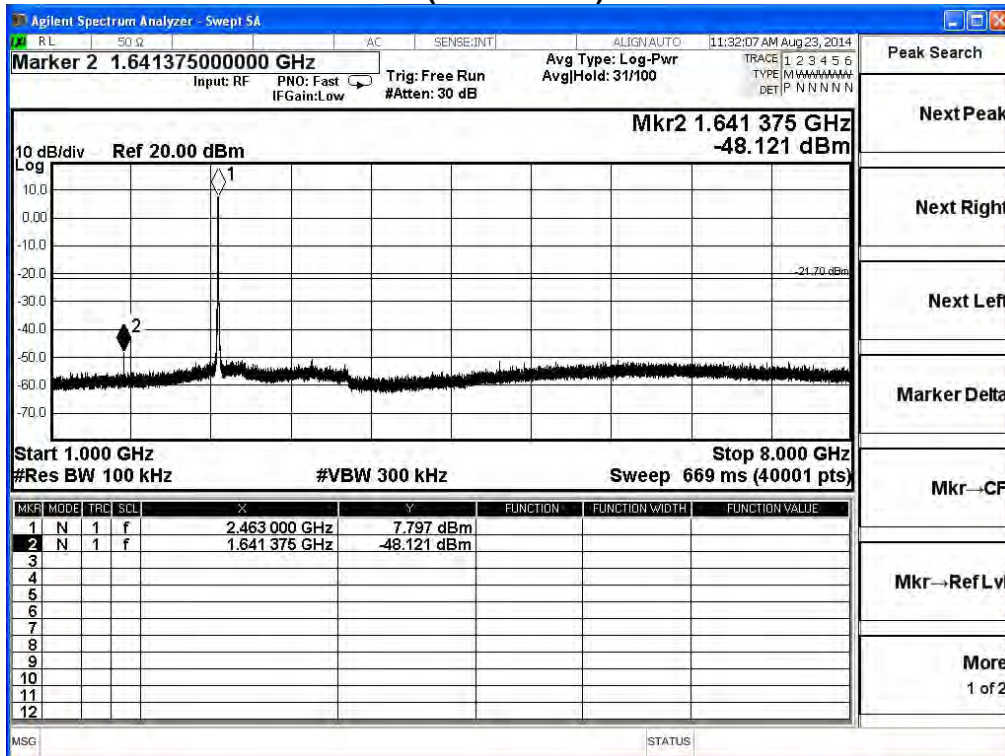

2462MHz (8GHz-16GHz) -802.11b

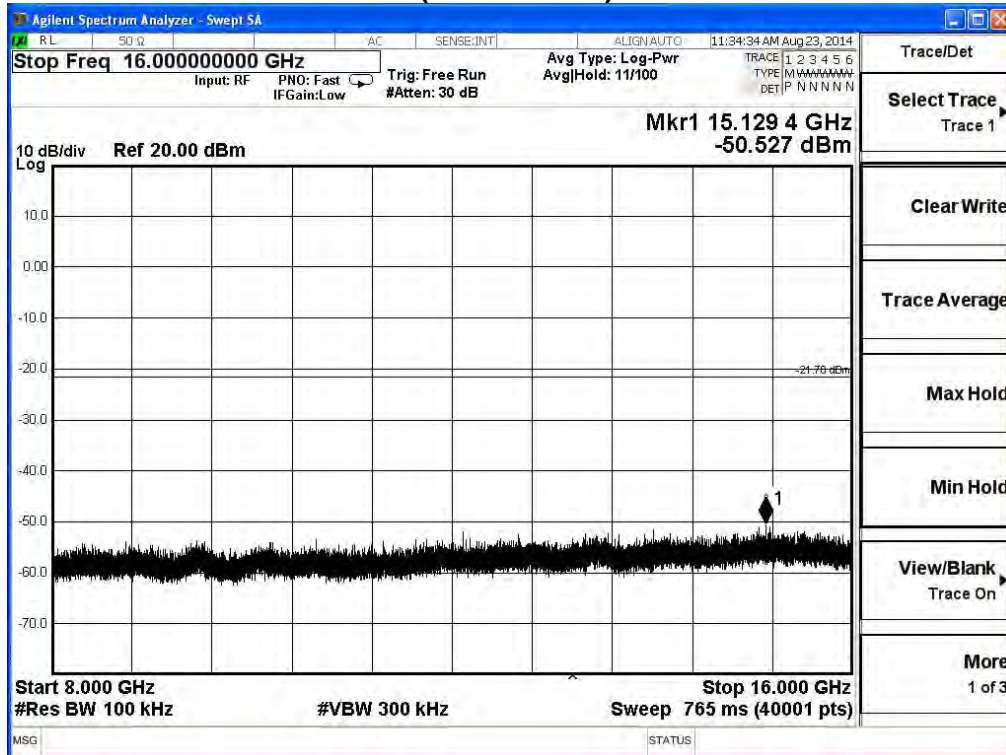

2462MHz (16GHz-25GHz) -802.11b

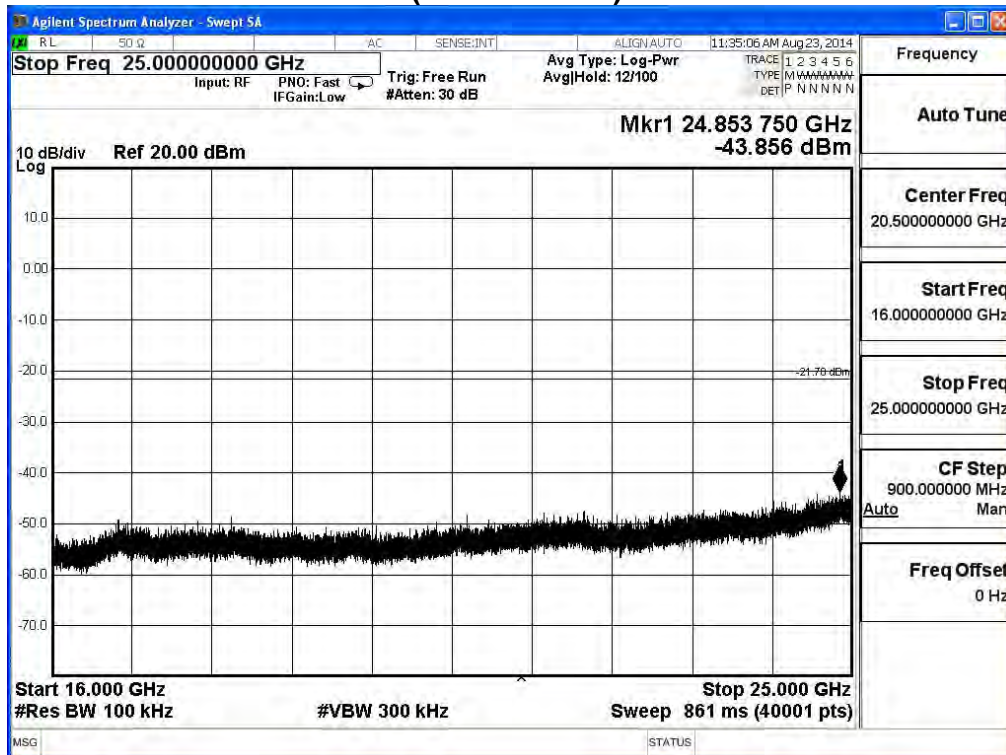

2412MHz (30MHz-1GHz)-802.11g

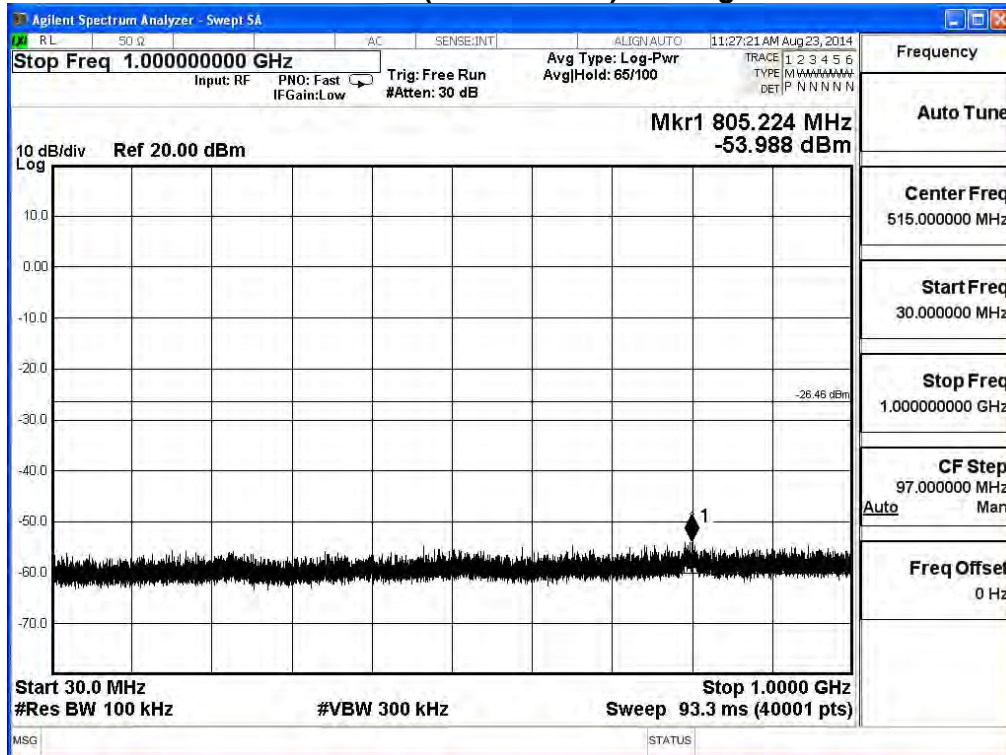

2412MHz (1GHz-8GHz) -802.11g

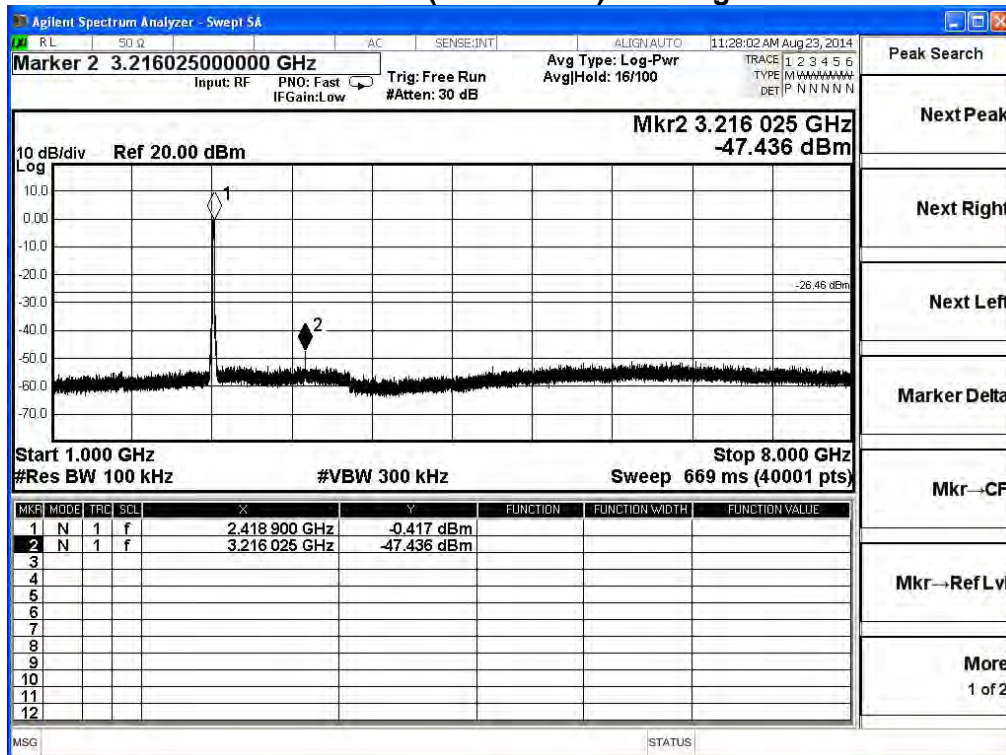

2412MHz (8GHz-16GHz) -802.11g

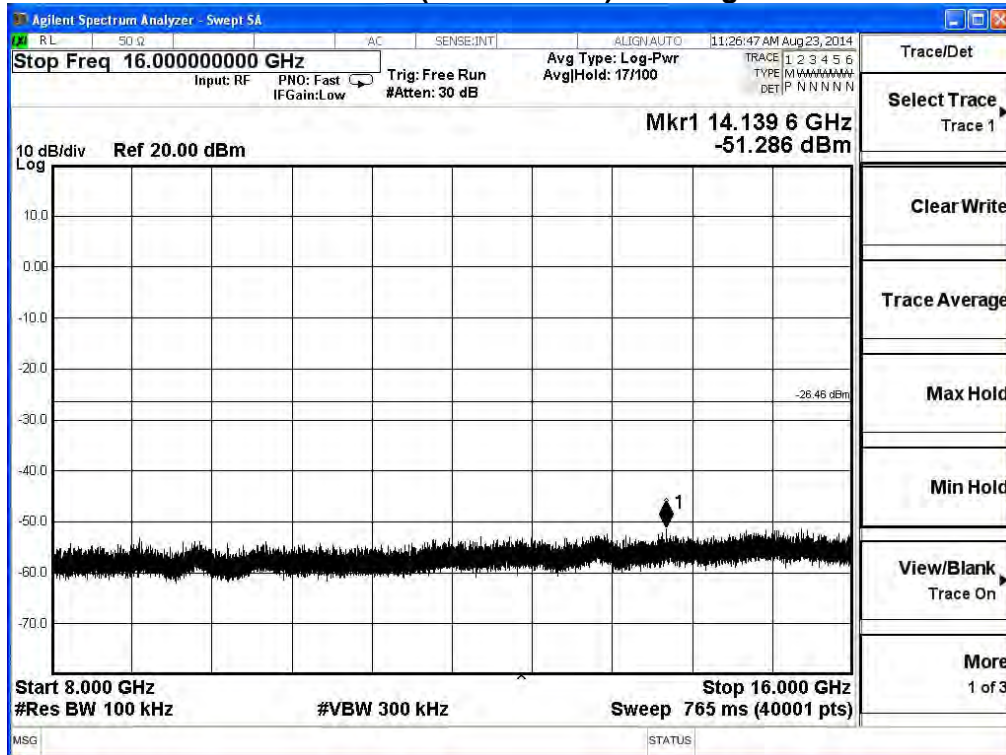

2412MHz (16GHz-25GHz) -802.11g

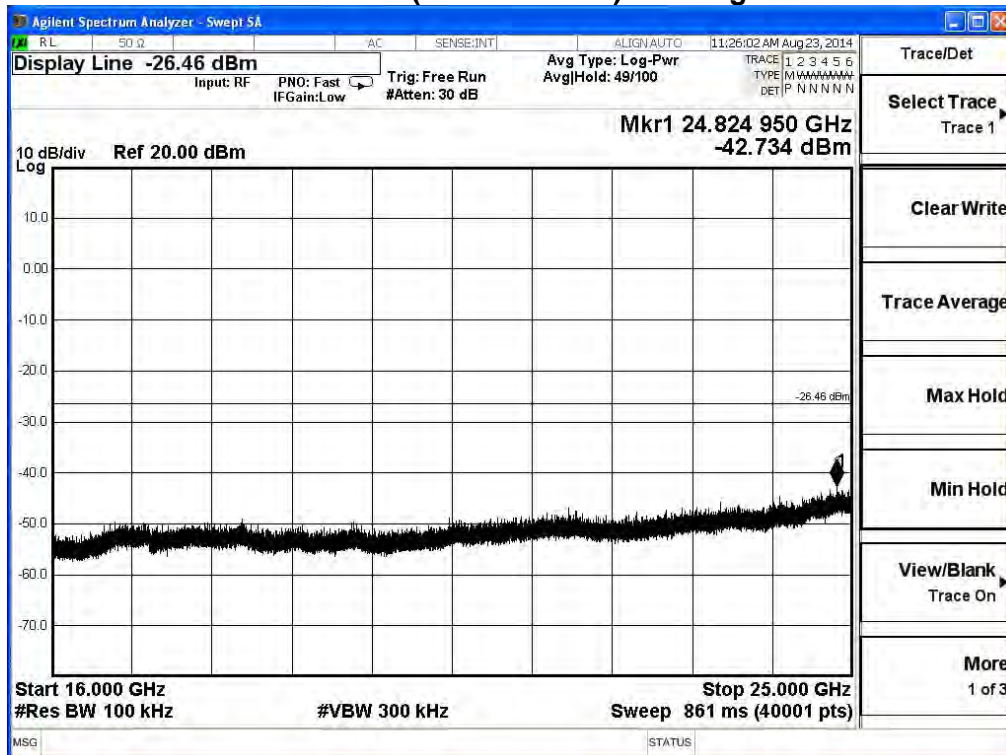

2437MHz (30MHz-1GHz)-802.11g

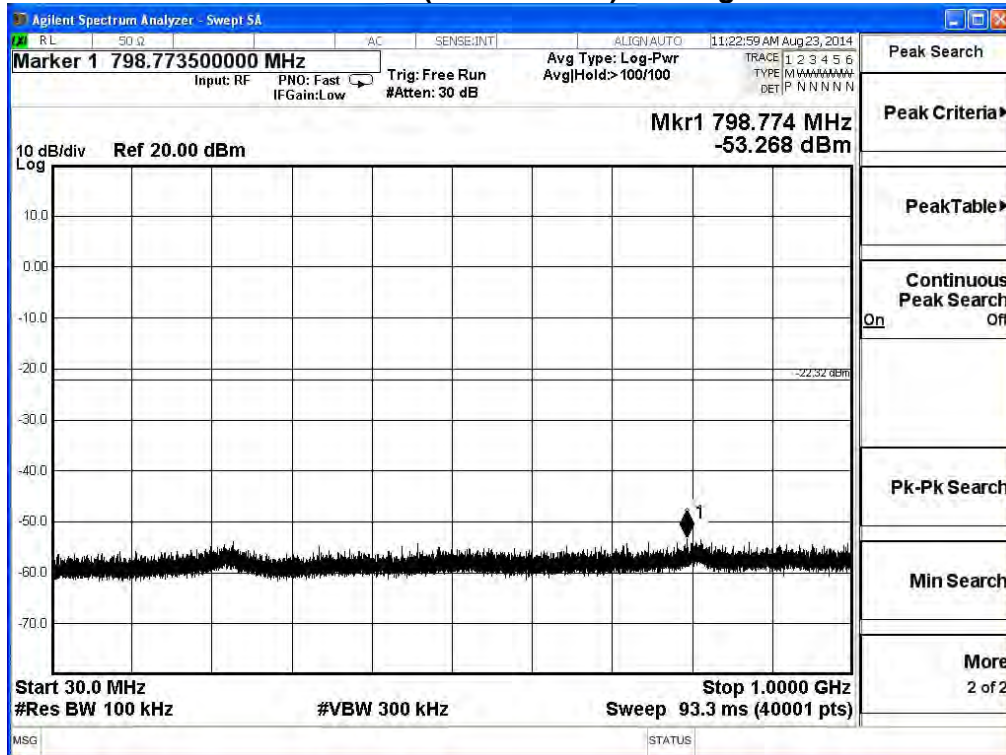

2437MHz (1GHz-8GHz) -802.11g

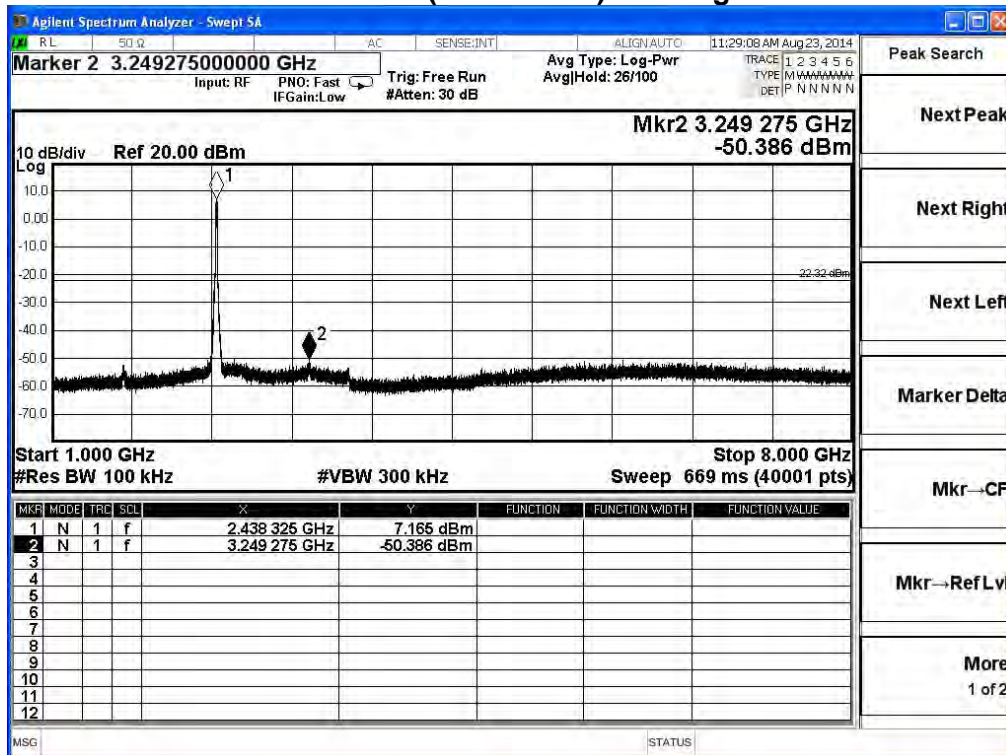

2437MHz (8GHz-16GHz) -802.11g

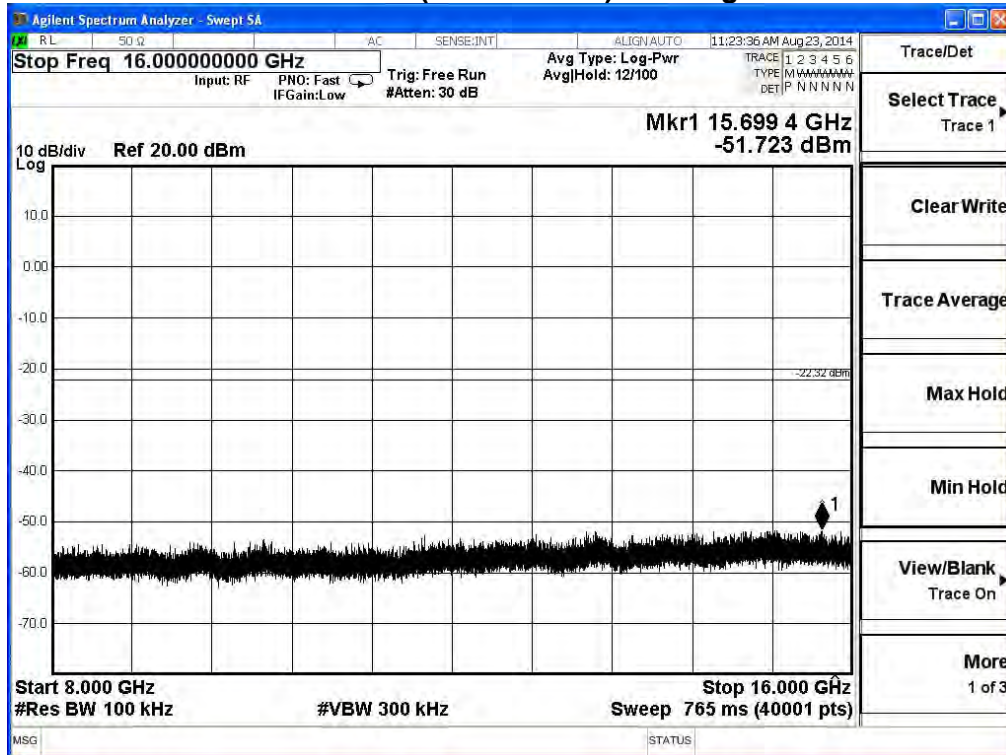

2437MHz (16GHz-25GHz) -802.11g

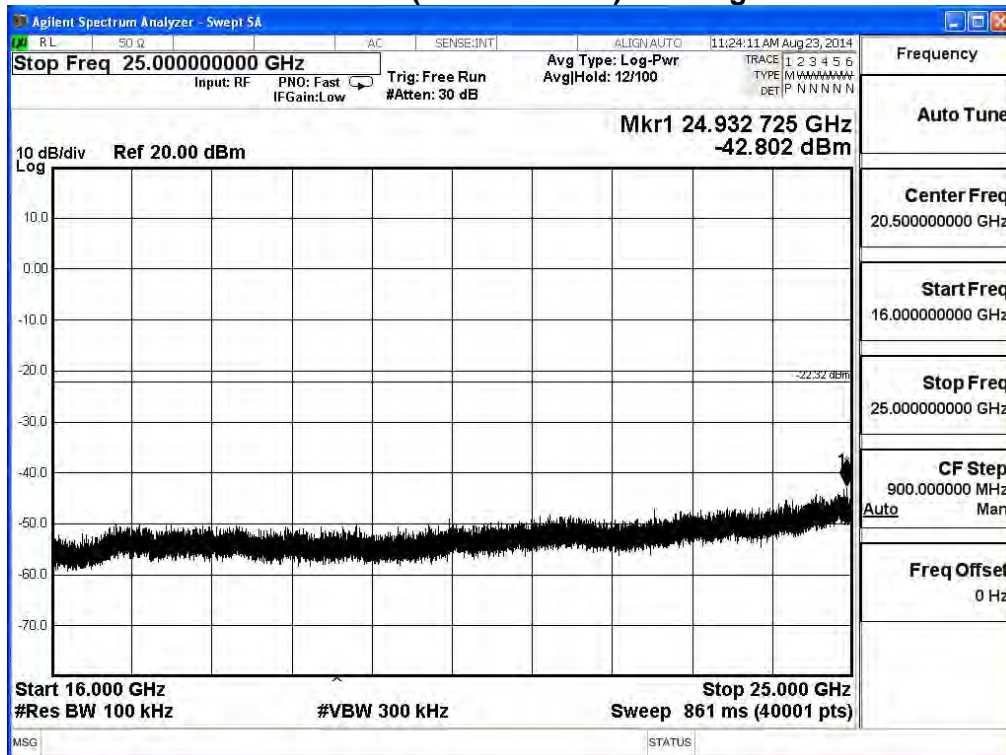

2462MHz (30MHz-1GHz)-802.11g

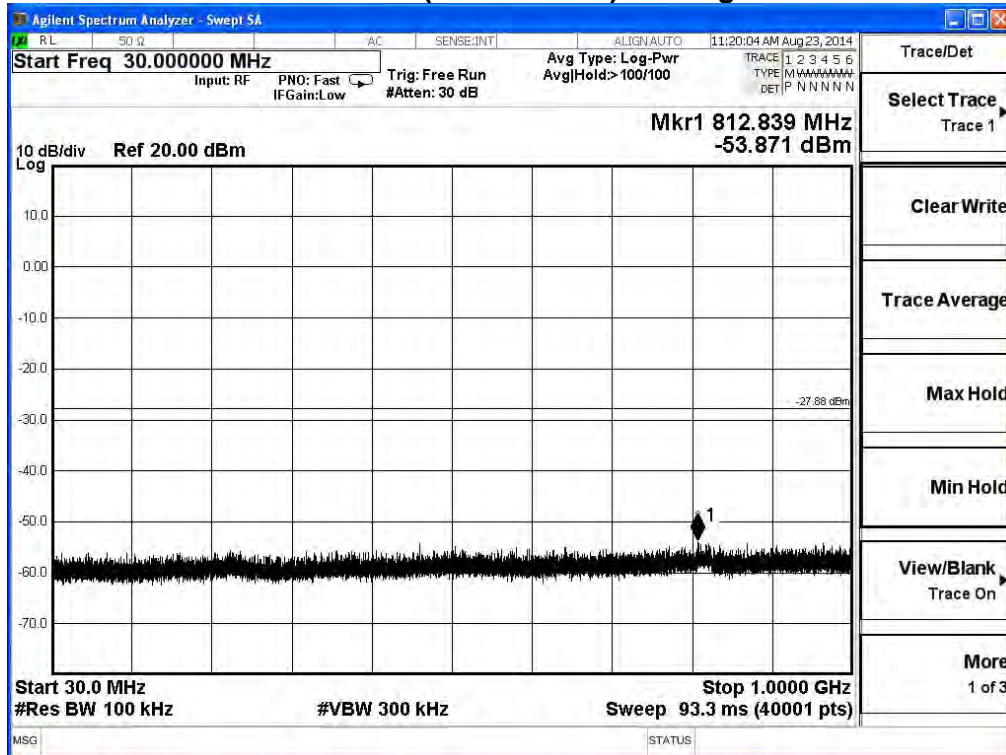

2462MHz (1GHz-8GHz) -802.11g

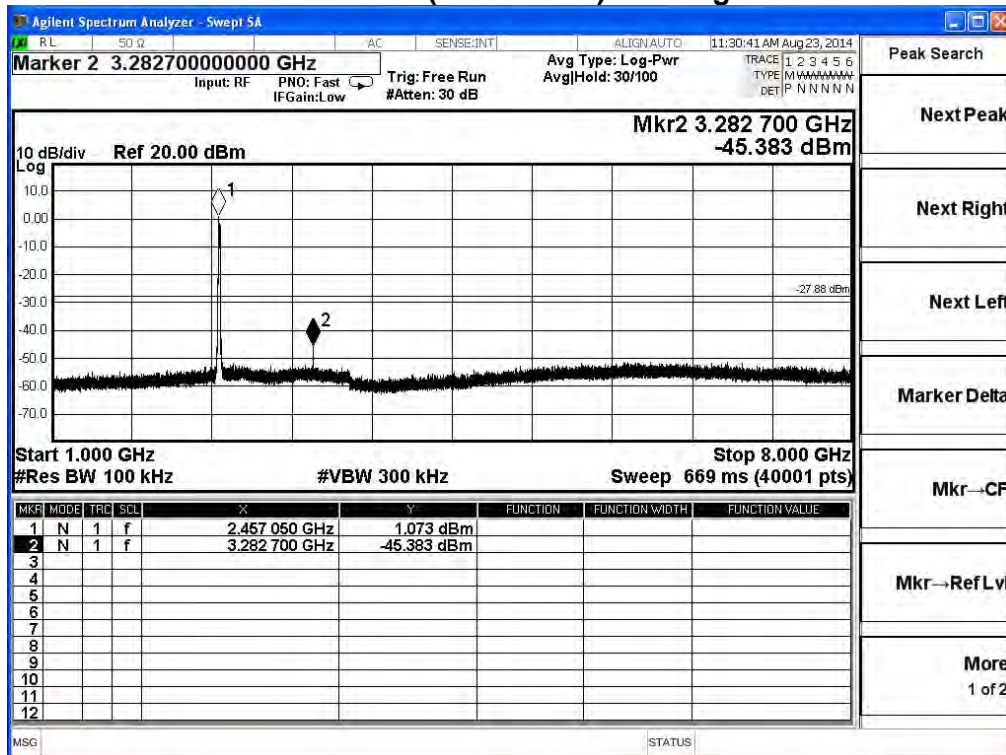

2462MHz (8GHz-16GHz) -802.11g

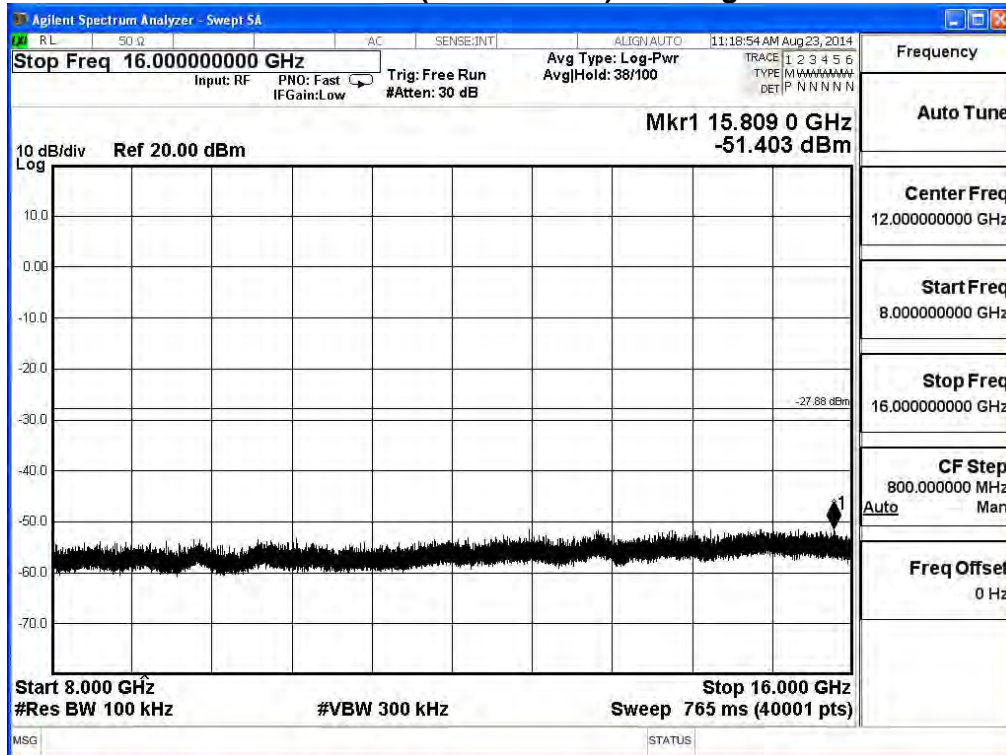

2462MHz (16GHz-25GHz) -802.11g

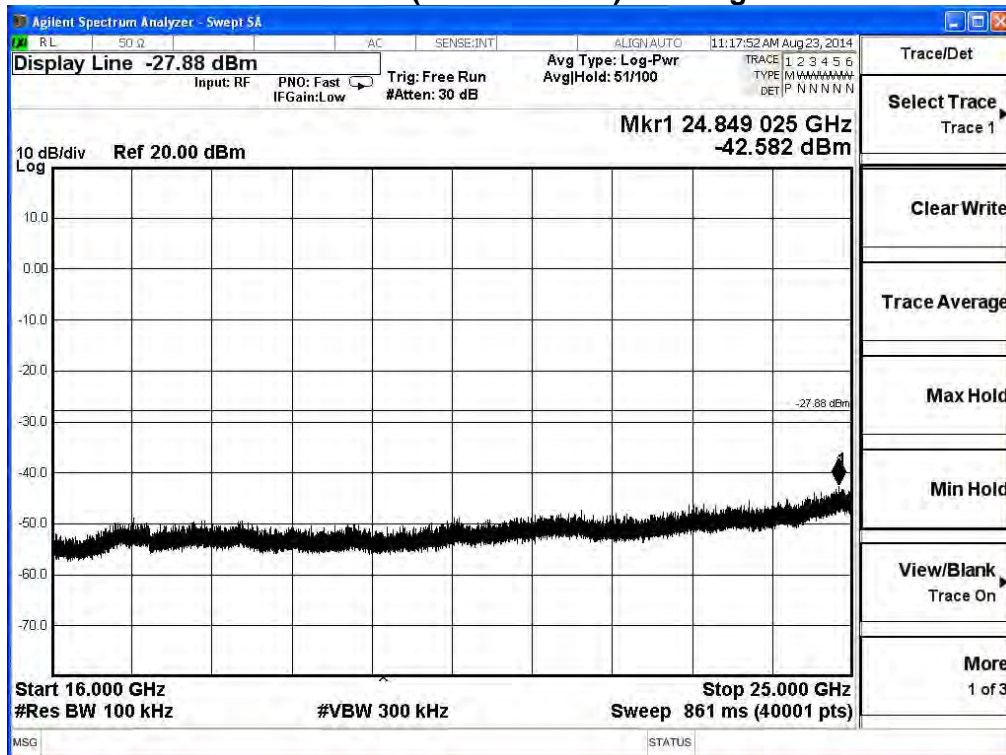



2412MHz (30MHz-1GHz)- 802.11n (20MHz)

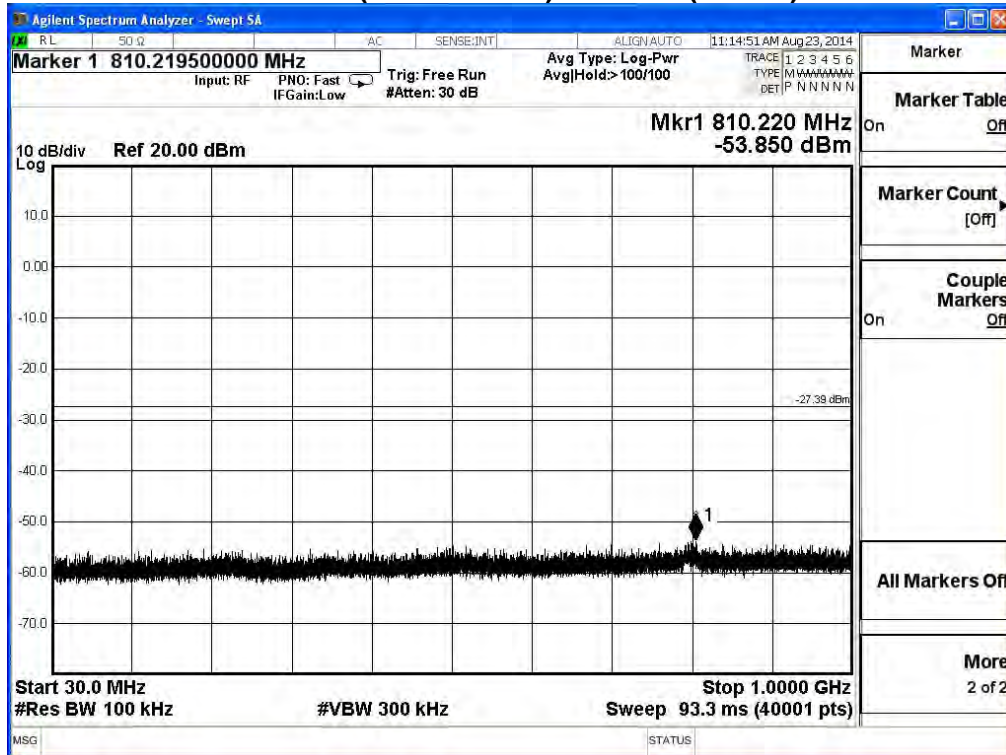

2412MHz (1GHz-8GHz) -802.11n (20MHz)

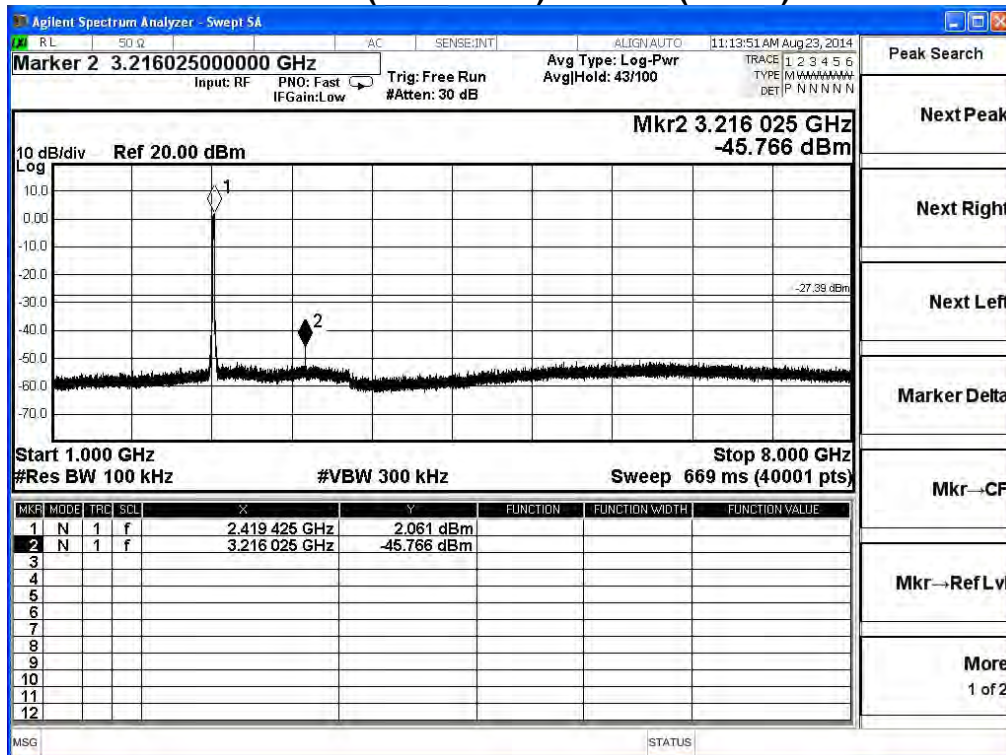

2412MHz (8GHz-16GHz) -802.11n (20MHz)

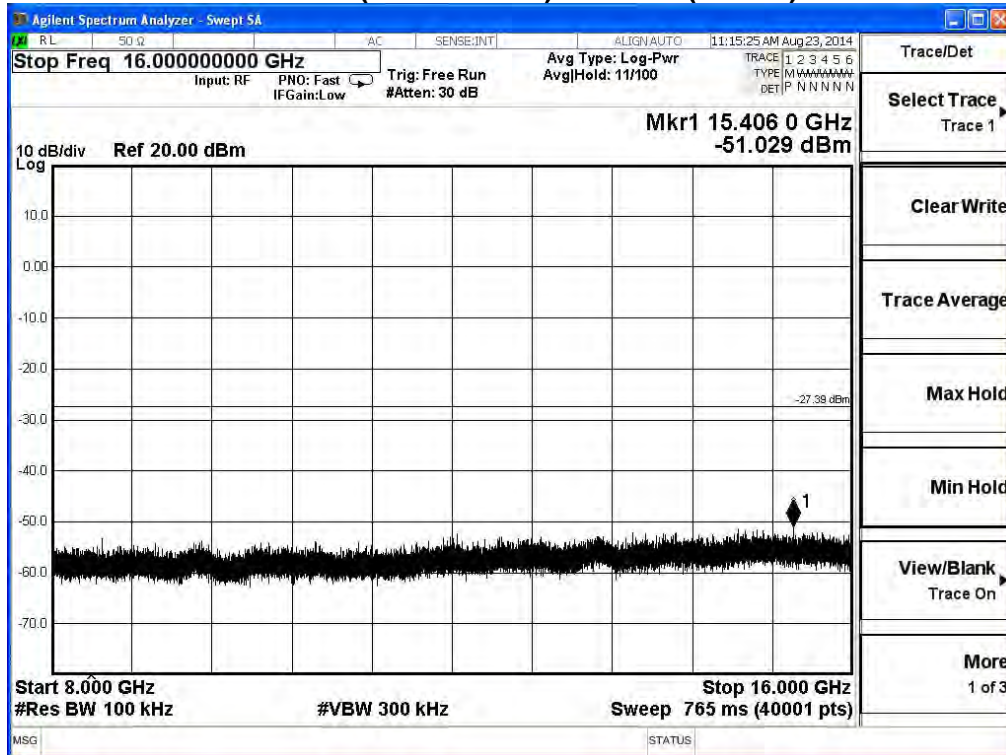

2412MHz (16GHz-25GHz) -802.11n (20MHz)

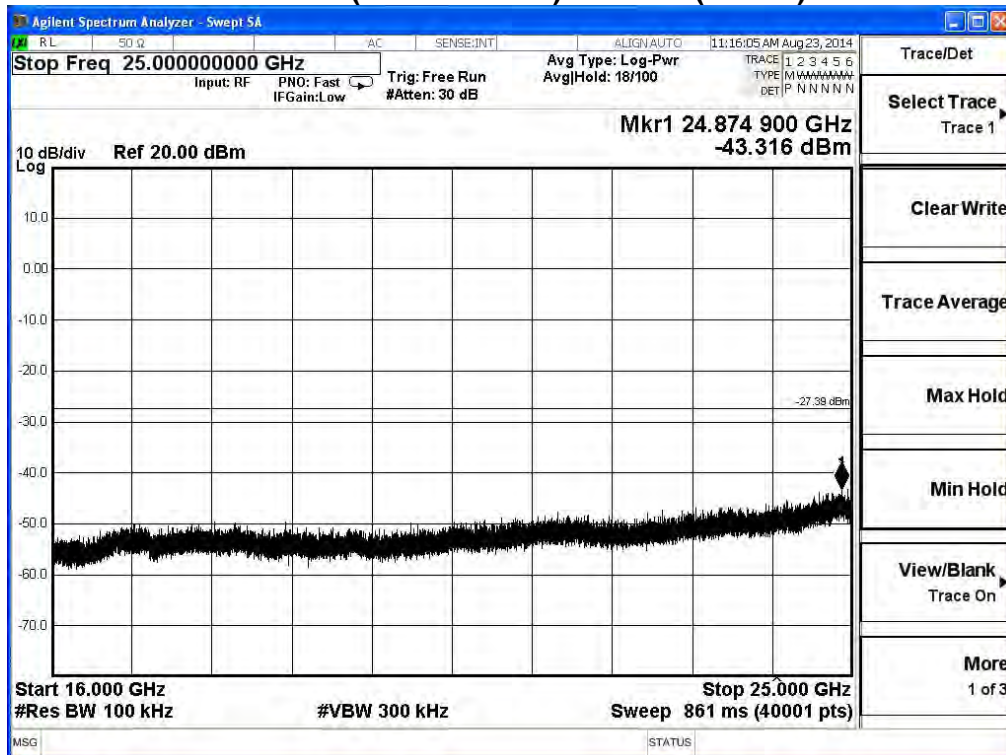

2437MHz (30MHz-1GHz)- 802.11n (20MHz)

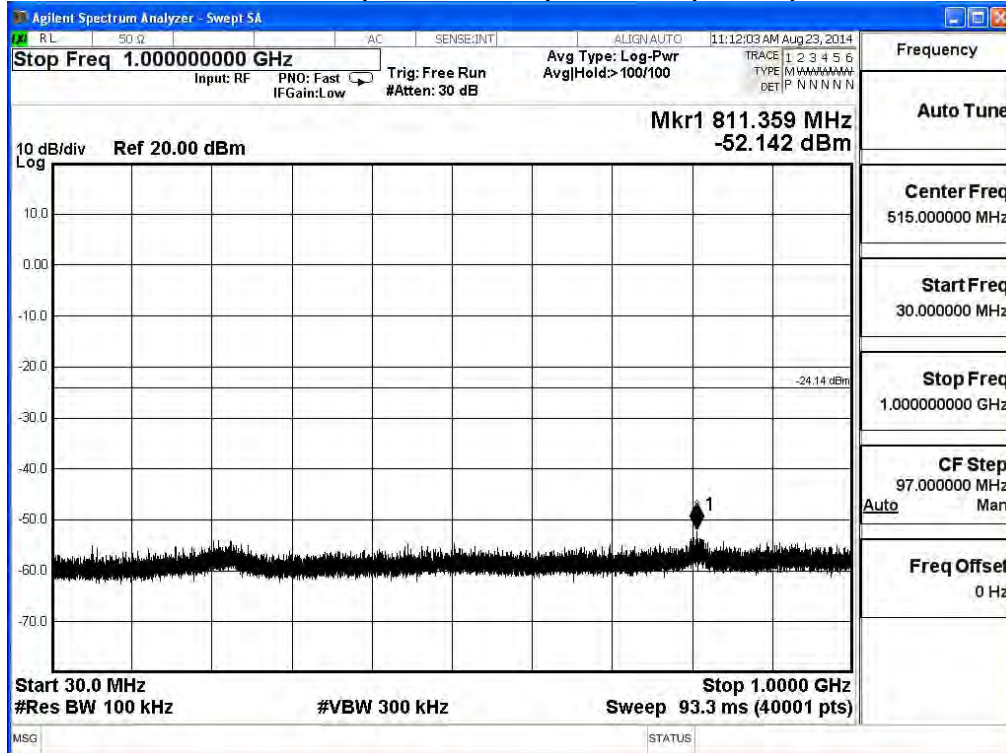

2437MHz (1GHz-8GHz) -802.11n (20MHz)

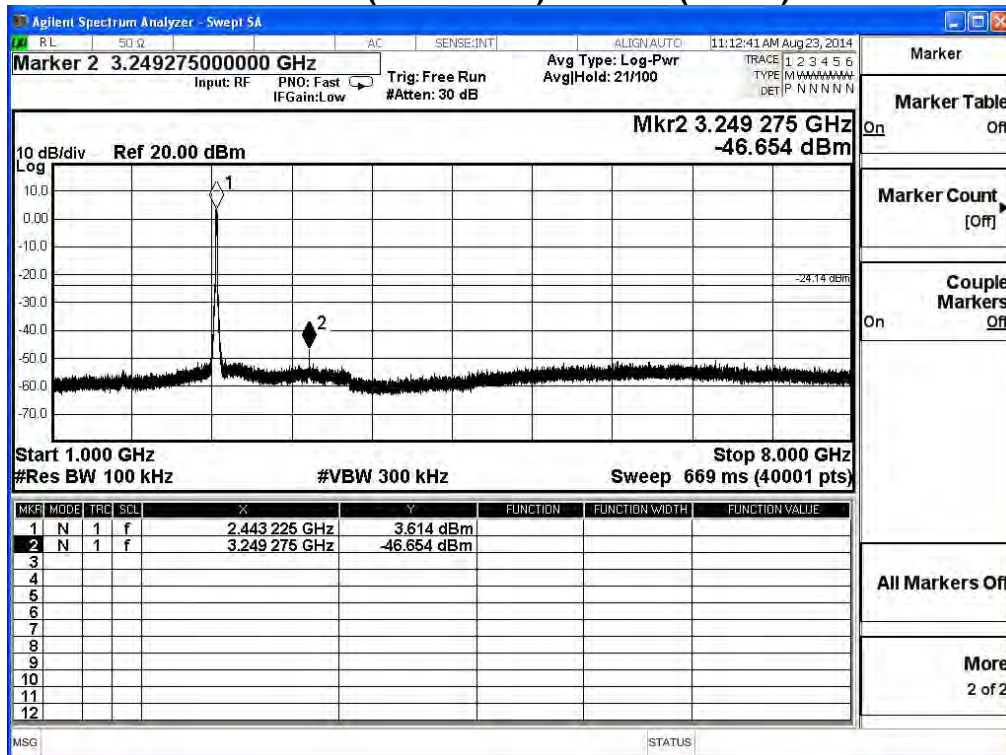

2437MHz (8GHz-16GHz) -802.11n (20MHz)

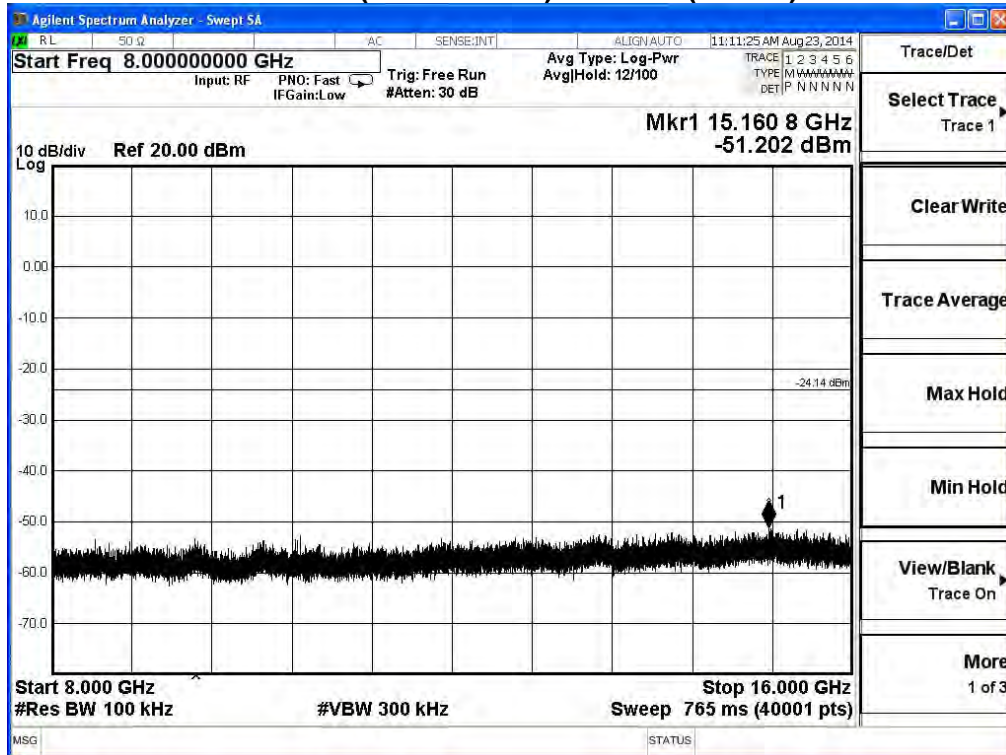

2437MHz (16GHz-25GHz) -802.11n (20MHz)

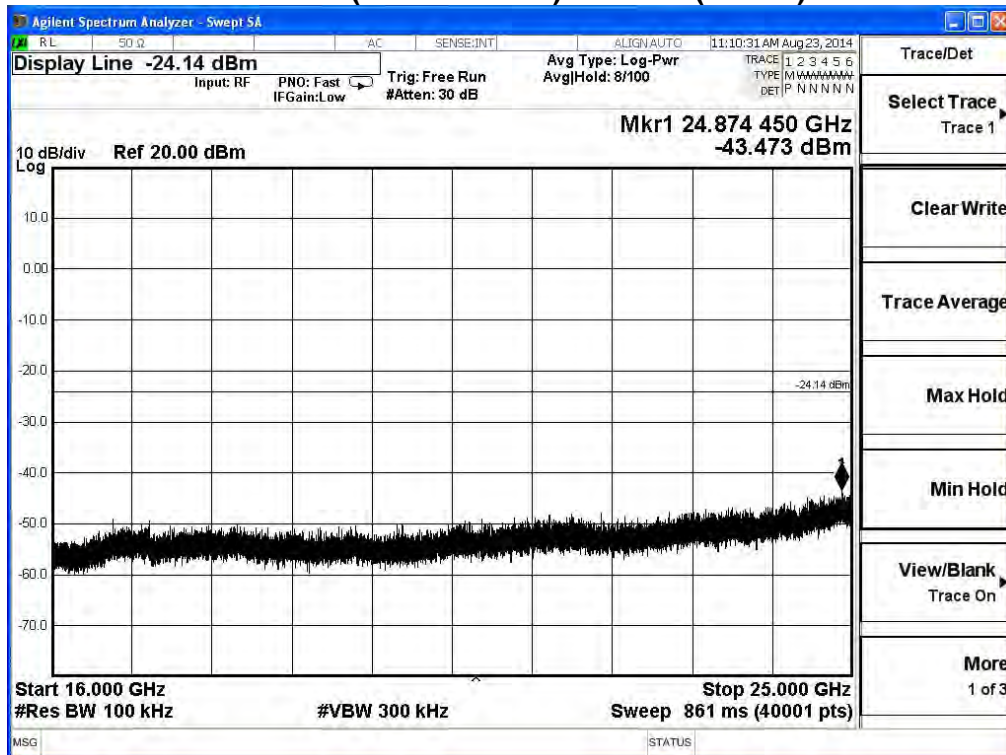

2462MHz (30MHz-1GHz)- 802.11n (20MHz)

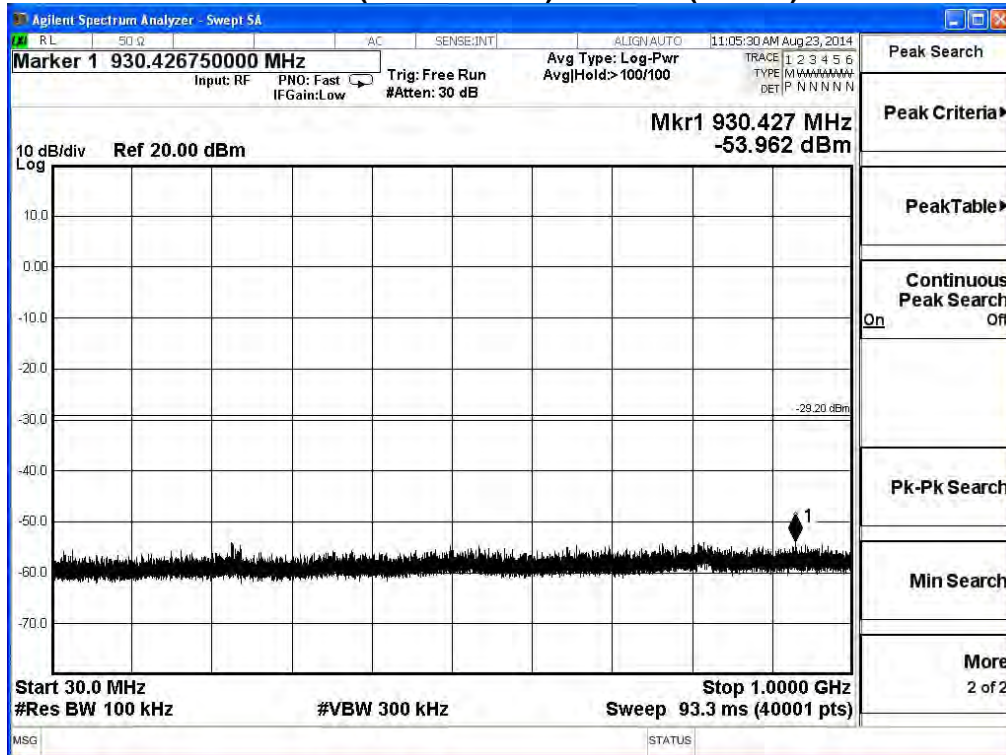

2462MHz (1GHz-8GHz) -802.11n (20MHz)

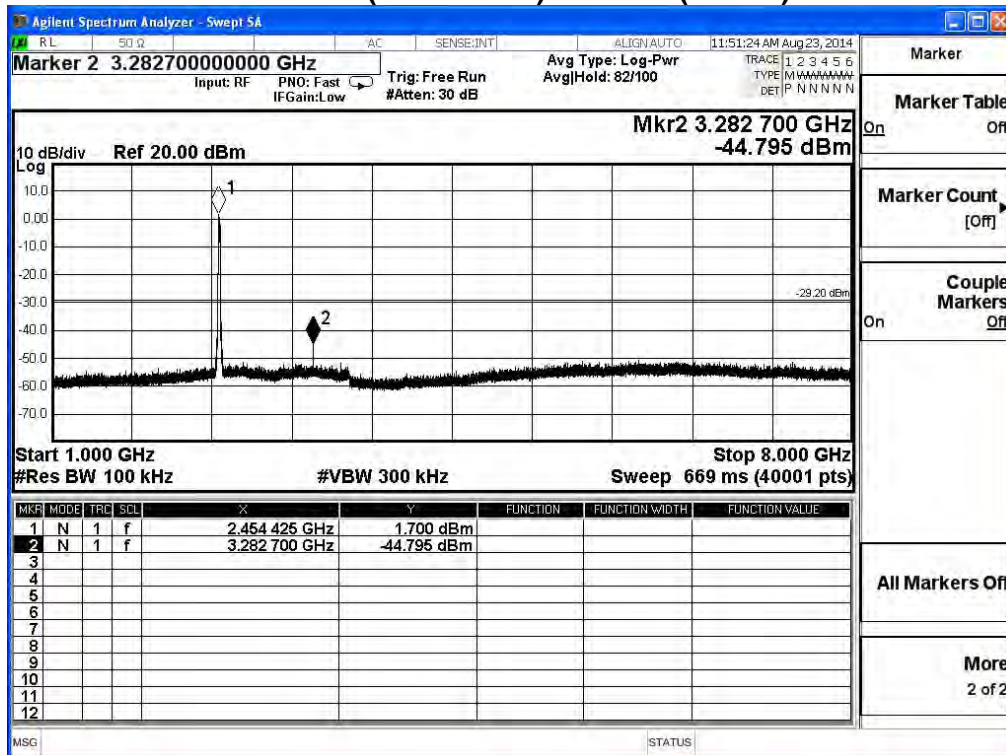

2462MHz (8GHz-16GHz) -802.11n (20MHz)

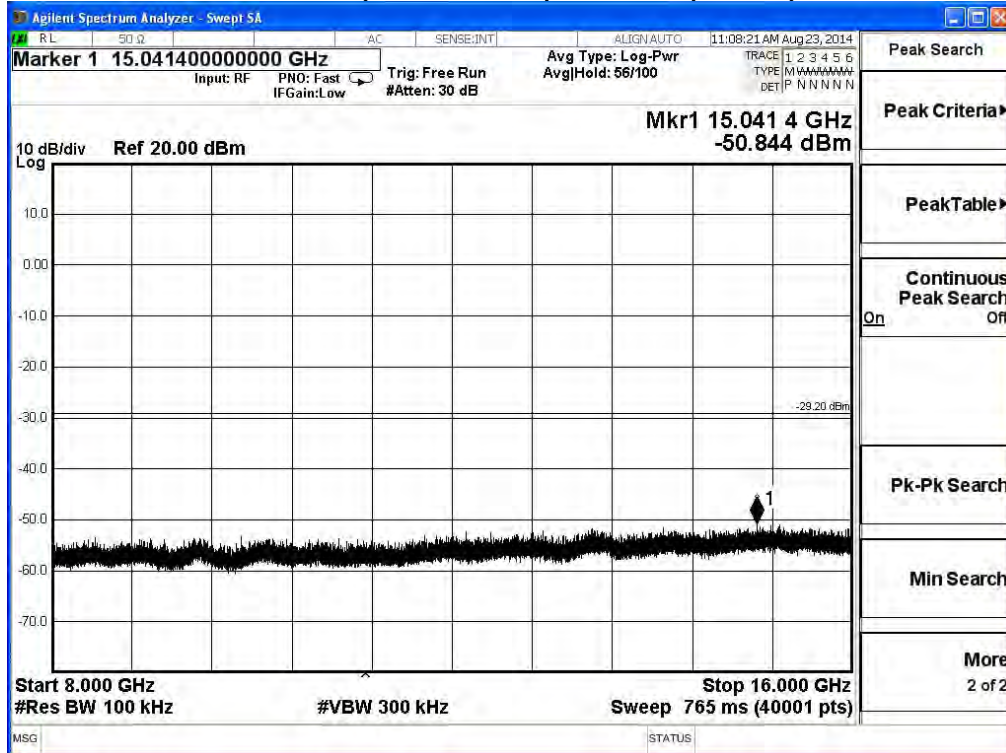

2462MHz (16GHz-25GHz) -802.11n (20MHz)

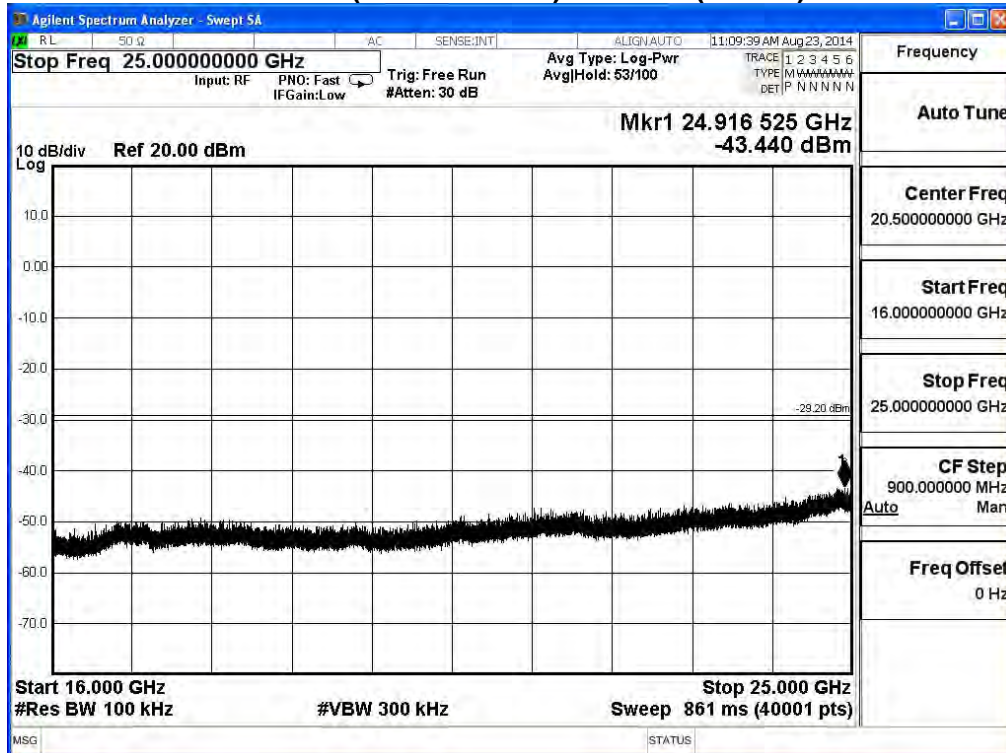

## 6. Radiated Emission Band Edge

### 6.1. Test Equipment

The following test equipments are used during the test:

Radiated Emission Band Edge / CB1

Instrument	Manufacturer	Model No.	Serial No	Next Cal. Date
Double Ridged Guide Horn Antenna	Schwarzback	BBHA 9120	D743	2015/02/12
Spectrum Analyzer	Agilent	E4440A	MY46187335	2015/01/12
k Type Cable	Huber Suhner	Sucoflex 102	25623/2	2015/02/10

Note: 1. All equipments that need to calibrate are with calibration period of 1 year.

### 6.2. Test Setup

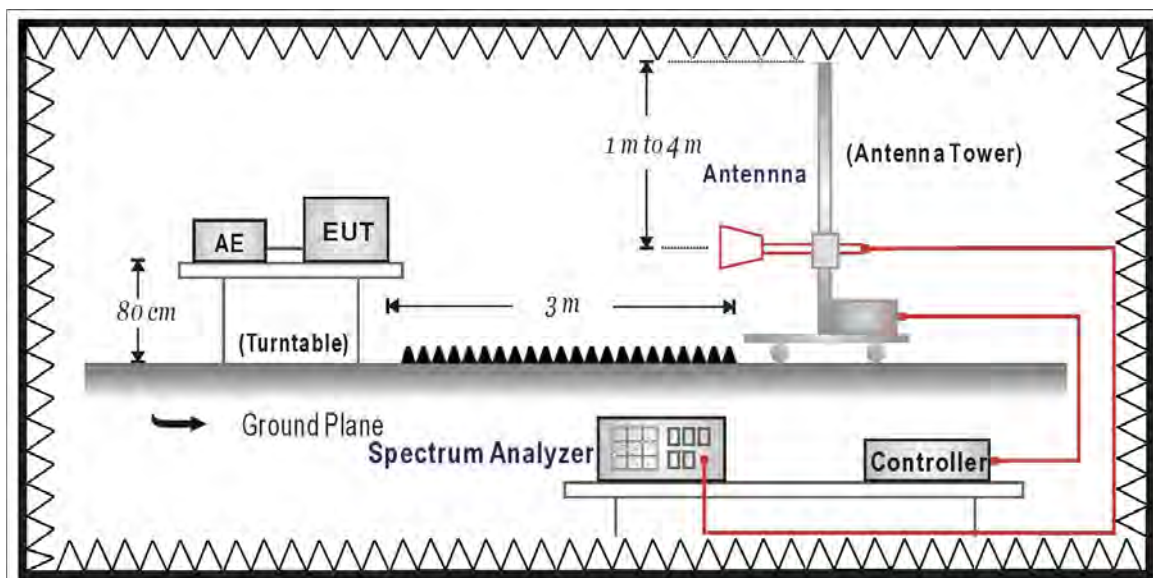

**6.3. Limits**

Emissions radiated outside of the specified frequency bands, except for harmonics, shall be attenuated by at least 20dB below the level of the fundamental or to the general radiated emission limits in paragraph 15.209, whichever is the lesser attenuation.

**6.4. Test Procedure**

The EUT was setup according to ANSI C63.4: 2009 and tested according to DTS test procedure of KDB558074 v03r01 for compliance to FCC 47CFR 15.247 requirements. The EUT and its simulators are placed on a turn table which is 0.8 meter above ground. The turn table can rotate 360 degrees to determine the position of the maximum emission level. The EUT was positioned such that the distance from antenna to the EUT was 3 meters.

The antenna can move up and down between 1 meter and 4 meters to find out the maximum emission level.

Both horizontal and vertical polarization of the antenna are set on measurement. In order to find the maximum emission, all of the interface cables must be manipulated according to ANSI C63.4: 2009 on radiated measurement.

**6.5. Test Specification**

According to FCC Part 15 Subpart C Paragraph 15.247: 2013

**6.6. Uncertainty**

The measurement uncertainty  
 $\pm 3.9$  dB above 1GHz



6.7. Test Result

Radiated is defined as

Site : CB1	Time : 2014/08/14 - 15:32
Limit : FCC_SpartC_15.209_03M_PK	Margin : 6
Probe : CB1_FCC_EFS_1-18G-1_0901 - VERTICAL	Power : AC 120V/60Hz
EUT : WIFI HD BABY CAM	Note : 802.11b_CH01

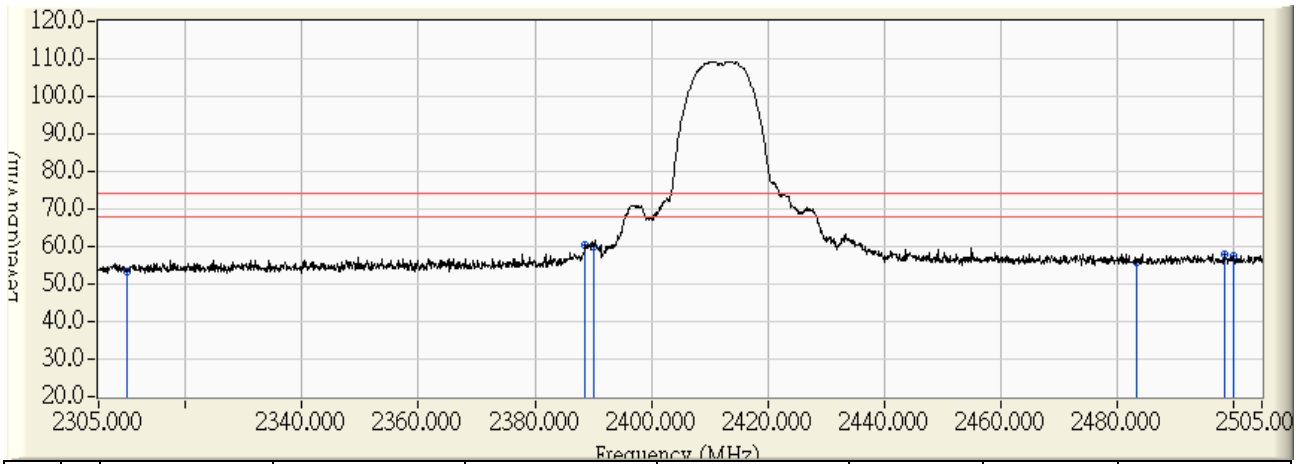

	Frequency (MHz)	Correct Factor (dB)	Reading Level (dBuV)	Measure Level (dBuV/m)	Margin (dB)	Limit (dBuV/m)	Detector Type
1	2310.000	30.411	22.791	53.202	-20.798	74.000	PEAK
2	* 2388.700	31.228	28.998	60.225	-13.775	74.000	PEAK
3	2390.000	31.241	28.727	59.968	-14.032	74.000	PEAK
4	2483.500	31.980	23.878	55.857	-18.143	74.000	PEAK
5	2498.500	31.939	26.000	57.939	-16.061	74.000	PEAK
6	2500.000	31.934	25.711	57.646	-16.354	74.000	PEAK

Note:

1. All readings above 1GHz are performed with peak and/or average measurements as necessary.
2. Peak measurements: RBW = 1MHz, VBW = 3 MHz, Sweep: Auto.
3. Average measurements: RBW = 1MHz, VBW = 10 Hz, Sweep: Auto.
4. “ \* ”, means this data is the worst emission level.
5. Measurement Level = Reading Level + Correct Factor.
6. The average measurement was not performed when the peak measured data under the limit of average detection.

Site : CB1	Time : 2014/08/14 - 15:31
Limit : FCC_SpartC_15.209_03M_AV	Margin : 6
Probe : CB1_FCC_EFS_1-18G-1_0901 - VERTICAL	Power : AC 120V/60Hz
EUT : WIFI HD BABY CAM	Note : 802.11b_CH01

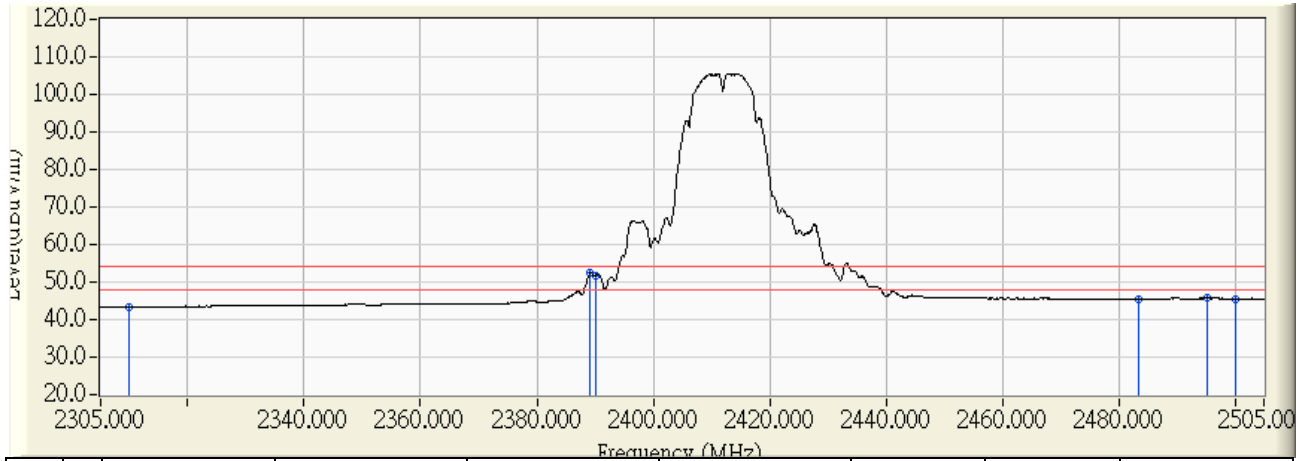

	Frequency (MHz)	Correct Factor (dB)	Reading Level (dBuV)	Measure Level (dBuV/m)	Margin (dB)	Limit (dBuV/m)	Detector Type
1	2310.000	30.411	12.972	43.383	-10.617	54.000	AVERAGE
2	* 2389.200	31.232	21.136	52.369	-1.631	54.000	AVERAGE
3	2390.000	31.241	20.531	51.772	-2.228	54.000	AVERAGE
4	2483.500	31.980	13.477	45.456	-8.544	54.000	AVERAGE
5	2495.200	31.948	13.721	45.669	-8.331	54.000	AVERAGE
6	2500.000	31.934	13.556	45.491	-8.509	54.000	AVERAGE

**Note:**

1. All readings above 1GHz are performed with peak and/or average measurements as necessary.
2. Peak measurements: RBW = 1MHz, VBW = 3 MHz, Sweep: Auto.
3. Average measurements: RBW = 1MHz, VBW = 10 Hz, Sweep: Auto.
4. “ \* ”, means this data is the worst emission level.
5. Measurement Level = Reading Level + Correct Factor.
6. The average measurement was not performed when the peak measured data under the limit of average detection.

Site : CB1	Time : 2014/08/14 - 15:35
Limit : FCC_SpartC_15.209_03M_PK	Margin : 6
Probe : CB1_FCC_EFS_1-18G-1_0901 - HORIZONTAL	Power : AC 120V/60Hz
EUT : WIFI HD BABY CAM	Note : 802.11b_CH01

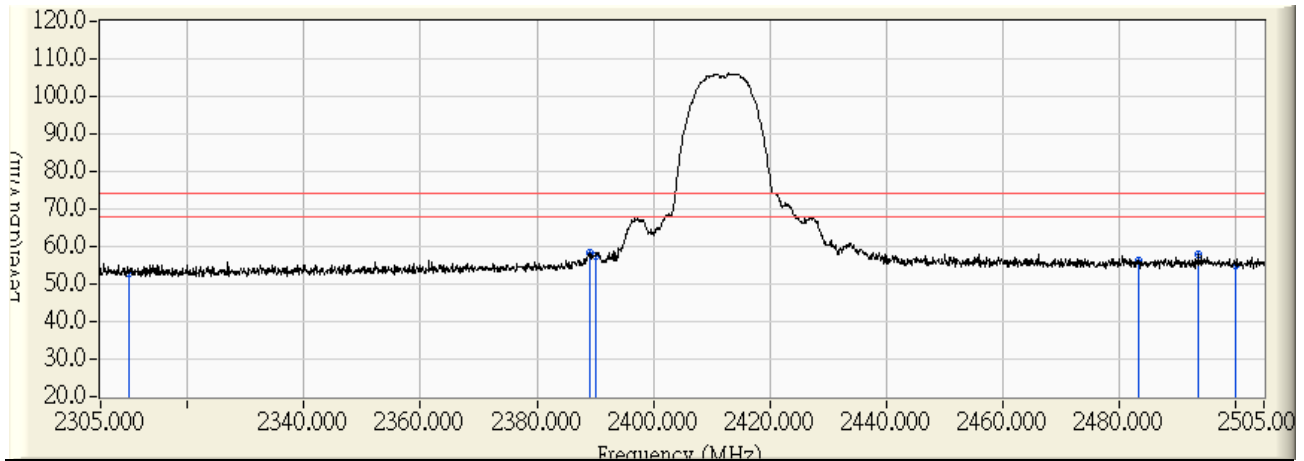

	Frequency (MHz)	Correct Factor (dB)	Reading Level (dBuV)	Measure Level (dBuV/m)	Margin (dB)	Limit (dBuV/m)	Detector Type
1	2310.000	30.411	22.692	53.103	-20.897	74.000	PEAK
2	* 2389.100	31.232	27.073	58.305	-15.695	74.000	PEAK
3	2390.000	31.241	26.171	57.412	-16.588	74.000	PEAK
4	2483.500	31.980	24.291	56.270	-17.730	74.000	PEAK
5	2493.700	31.952	25.975	57.927	-16.073	74.000	PEAK
6	2500.000	31.934	23.024	54.959	-19.041	74.000	PEAK

**Note:**

1. All readings above 1GHz are performed with peak and/or average measurements as necessary.
2. Peak measurements: RBW = 1MHz, VBW = 3 MHz, Sweep: Auto.
3. Average measurements: RBW = 1MHz, VBW = 10 Hz, Sweep: Auto.
4. “ \* ”, means this data is the worst emission level.
5. Measurement Level = Reading Level + Correct Factor.
6. The average measurement was not performed when the peak measured data under the limit of average detection.

Site : CB1	Time : 2014/08/14 - 15:36
Limit : FCC_SpartC_15.209_03M_AV	Margin : 6
Probe : CB1_FCC_EFS_1-18G-1_0901 - HORIZONTAL	Power : AC 120V/60Hz
EUT : WIFI HD BABY CAM	Note : 802.11b_CH01

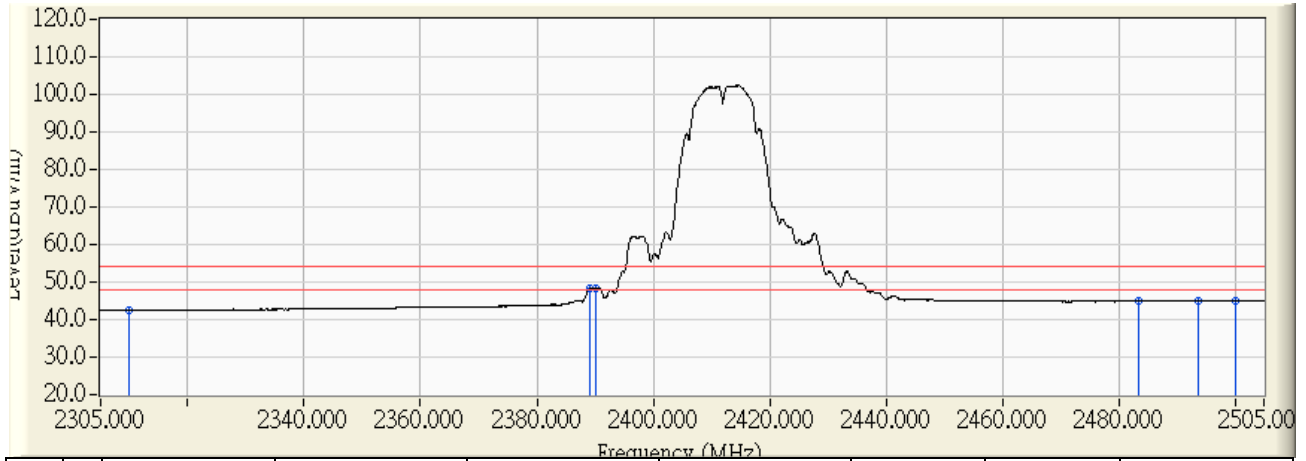

	Frequency (MHz)	Correct Factor (dB)	Reading Level (dBuV)	Measure Level (dBuV/m)	Margin (dB)	Limit (dBuV/m)	Detector Type
1	2310.000	30.411	12.057	42.468	-11.532	54.000	AVERAGE
2	* 2389.000	31.231	17.027	48.258	-5.742	54.000	AVERAGE
3	2390.000	31.241	16.968	48.209	-5.791	54.000	AVERAGE
4	2483.500	31.980	12.874	44.853	-9.147	54.000	AVERAGE
5	2493.600	31.952	12.962	44.914	-9.086	54.000	AVERAGE
6	2500.000	31.934	12.895	44.830	-9.170	54.000	AVERAGE

**Note:**

1. All readings above 1GHz are performed with peak and/or average measurements as necessary.
2. Peak measurements: RBW = 1MHz, VBW = 3 MHz, Sweep: Auto.
3. Average measurements: RBW = 1MHz, VBW = 10 Hz, Sweep: Auto.
4. “ \* ”, means this data is the worst emission level.
5. Measurement Level = Reading Level + Correct Factor.
6. The average measurement was not performed when the peak measured data under the limit of average detection.

Site : CB1	Time : 2014/08/14 - 15:54
Limit : FCC_SpartC_15.209_03M_PK	Margin : 6
Probe : CB1_FCC_EFS_1-18G-1_0901 - HORIZONTAL	Power : AC 120V/60Hz
EUT : WIFI HD BABY CAM	Note : 802.11b_CH11

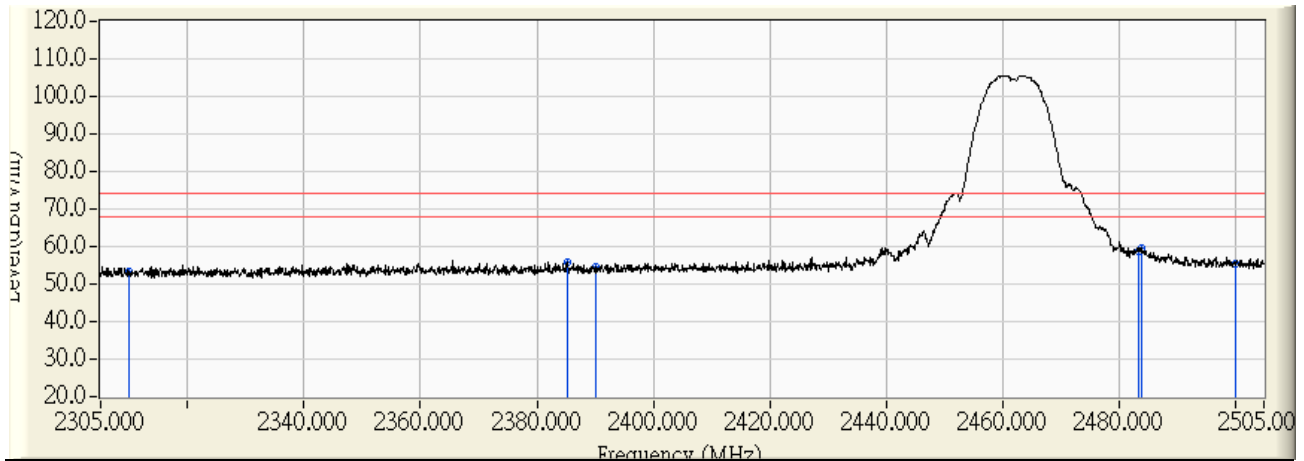

	Frequency (MHz)	Correct Factor (dB)	Reading Level (dBuV)	Measure Level (dBuV/m)	Margin (dB)	Limit (dBuV/m)	Detector Type
1	2310.000	30.411	22.886	53.297	-20.703	74.000	PEAK
2	2385.200	31.191	24.806	55.997	-18.003	74.000	PEAK
3	2390.000	31.241	23.142	54.383	-19.617	74.000	PEAK
4	2483.500	31.980	26.965	58.944	-15.056	74.000	PEAK
5	* 2483.900	31.978	27.562	59.540	-14.460	74.000	PEAK
6	2500.000	31.934	23.638	55.573	-18.427	74.000	PEAK

**Note:**

1. All readings above 1GHz are performed with peak and/or average measurements as necessary.
2. Peak measurements: RBW = 1MHz, VBW = 3 MHz, Sweep: Auto.
3. Average measurements: RBW = 1MHz, VBW = 10 Hz, Sweep: Auto.
4. “ \* ”, means this data is the worst emission level.
5. Measurement Level = Reading Level + Correct Factor.
6. The average measurement was not performed when the peak measured data under the limit of average detection.

Site : CB1	Time : 2014/08/14 - 15:55
Limit : FCC_SpartC_15.209_03M_AV	Margin : 6
Probe : CB1_FCC_EFS_1-18G-1_0901 - HORIZONTAL	Power : AC 120V/60Hz
EUT : WIFI HD BABY CAM	Note : 802.11b_CH11

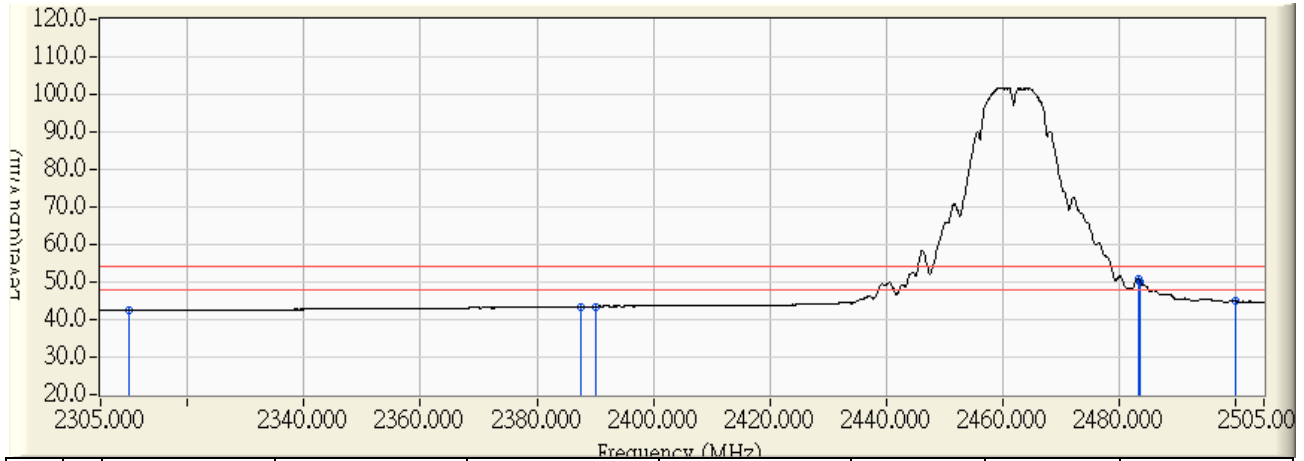

	Frequency (MHz)	Correct Factor (dB)	Reading Level (dBuV)	Measure Level (dBuV/m)	Margin (dB)	Limit (dBuV/m)	Detector Type
1	2310.000	30.411	12.086	42.497	-11.503	54.000	AVERAGE
2	2387.500	31.215	12.260	43.475	-10.525	54.000	AVERAGE
3	2390.000	31.241	12.257	43.498	-10.502	54.000	AVERAGE
4	* 2483.500	31.980	18.673	50.652	-3.348	54.000	AVERAGE
5	2483.800	31.978	17.940	49.919	-4.081	54.000	AVERAGE
6	2500.000	31.934	12.896	44.831	-9.169	54.000	AVERAGE

**Note:**

1. All readings above 1GHz are performed with peak and/or average measurements as necessary.
2. Peak measurements: RBW = 1MHz, VBW = 3 MHz, Sweep: Auto.
3. Average measurements: RBW = 1MHz, VBW = 10 Hz, Sweep: Auto.
4. “ \* ”, means this data is the worst emission level.
5. Measurement Level = Reading Level + Correct Factor.
6. The average measurement was not performed when the peak measured data under the limit of average detection.

Site : CB1	Time : 2014/08/14 - 15:51
Limit : FCC_SpartC_15.209_03M_PK	Margin : 6
Probe : CB1_FCC_EFS_1-18G-1_0901 - VERTICAL	Power : AC 120V/60Hz
EUT : WIFI HD BABY CAM	Note : 802.11b_CH11

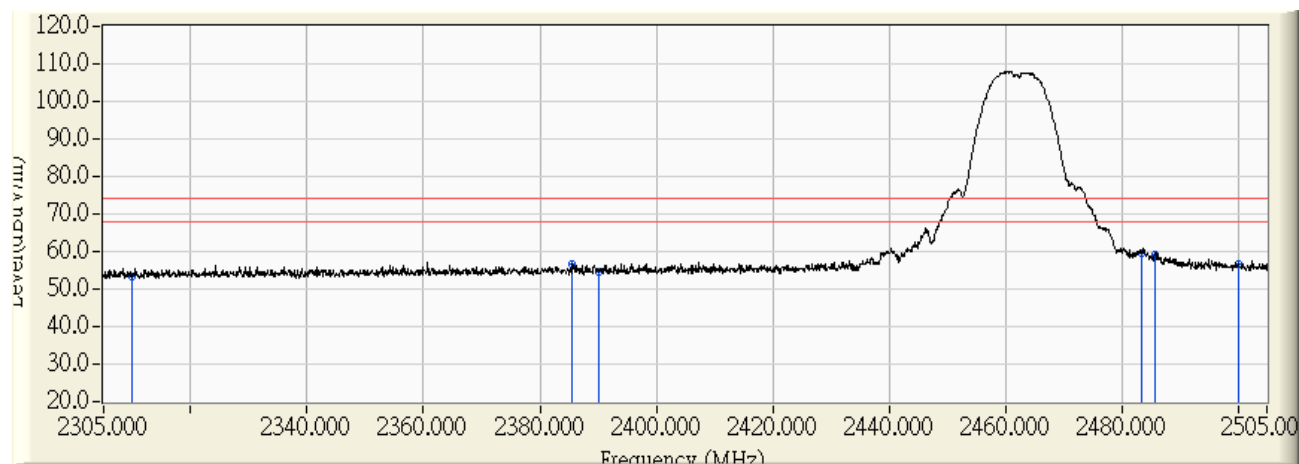

	Frequency (MHz)	Correct Factor (dB)	Reading Level (dBuV)	Measure Level (dBuV/m)	Margin (dB)	Limit (dBuV/m)	Detector Type
1	2310.000	30.411	22.933	53.344	-20.656	74.000	PEAK
2	2385.400	31.193	25.424	56.617	-17.383	74.000	PEAK
3	2390.000	31.241	23.439	54.680	-19.320	74.000	PEAK
4	* 2483.500	31.980	27.812	59.791	-14.209	74.000	PEAK
5	2485.700	31.973	27.056	59.029	-14.971	74.000	PEAK
6	2500.000	31.934	24.589	56.524	-17.476	74.000	PEAK

**Note:**

1. All readings above 1GHz are performed with peak and/or average measurements as necessary.
2. Peak measurements: RBW = 1MHz, VBW = 3 MHz, Sweep: Auto.
3. Average measurements: RBW = 1MHz, VBW = 10 Hz, Sweep: Auto.
4. “ \* ”, means this data is the worst emission level.
5. Measurement Level = Reading Level + Correct Factor.
6. The average measurement was not performed when the peak measured data under the limit of average detection.

Site : CB1	Time : 2014/08/14 - 15:50
Limit : FCC_SpartC_15.209_03M_AV	Margin : 6
Probe : CB1_FCC_EFS_1-18G-1_0901 - VERTICAL	Power : AC 120V/60Hz
EUT : WIFI HD BABY CAM	Note : 802.11b_CH11

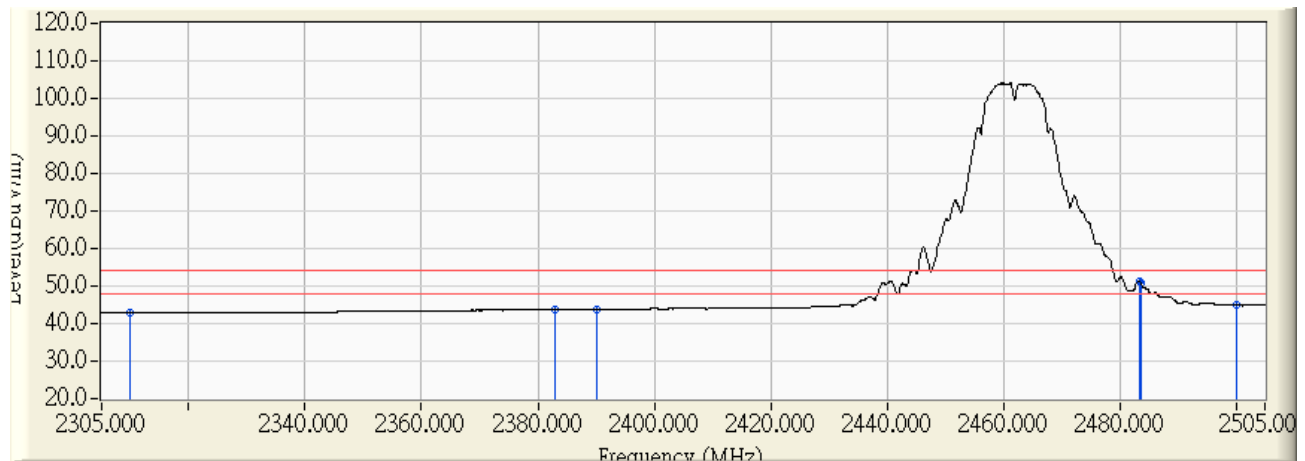

	Frequency (MHz)	Correct Factor (dB)	Reading Level (dBuV)	Measure Level (dBuV/m)	Margin (dB)	Limit (dBuV/m)	Detector Type
1	2310.000	30.411	12.389	42.800	-11.200	54.000	AVERAGE
2	2382.900	31.167	12.485	43.652	-10.348	54.000	AVERAGE
3	2390.000	31.241	12.639	43.880	-10.120	54.000	AVERAGE
4	* 2483.500	31.980	19.138	51.117	-2.883	54.000	AVERAGE
5	2483.600	31.979	18.913	50.892	-3.108	54.000	AVERAGE
6	2500.000	31.934	12.927	44.862	-9.138	54.000	AVERAGE

**Note:**

1. All readings above 1GHz are performed with peak and/or average measurements as necessary.
2. Peak measurements: RBW = 1MHz, VBW = 3 MHz, Sweep: Auto.
3. Average measurements: RBW = 1MHz, VBW = 10 Hz, Sweep: Auto.
4. “ \* ”, means this data is the worst emission level.
5. Measurement Level = Reading Level + Correct Factor.
6. The average measurement was not performed when the peak measured data under the limit of average detection.



Site : CB1	Time : 2014/08/14 - 16:27
Limit : FCC_SpartC_15.209_03M_PK	Margin : 6
Probe : CB1_FCC_EFS_1-18G-1_0901 - HORIZONTAL	Power : AC 120V/60Hz
EUT : WIFI HD BABY CAM	Note : 802.11g_CH01

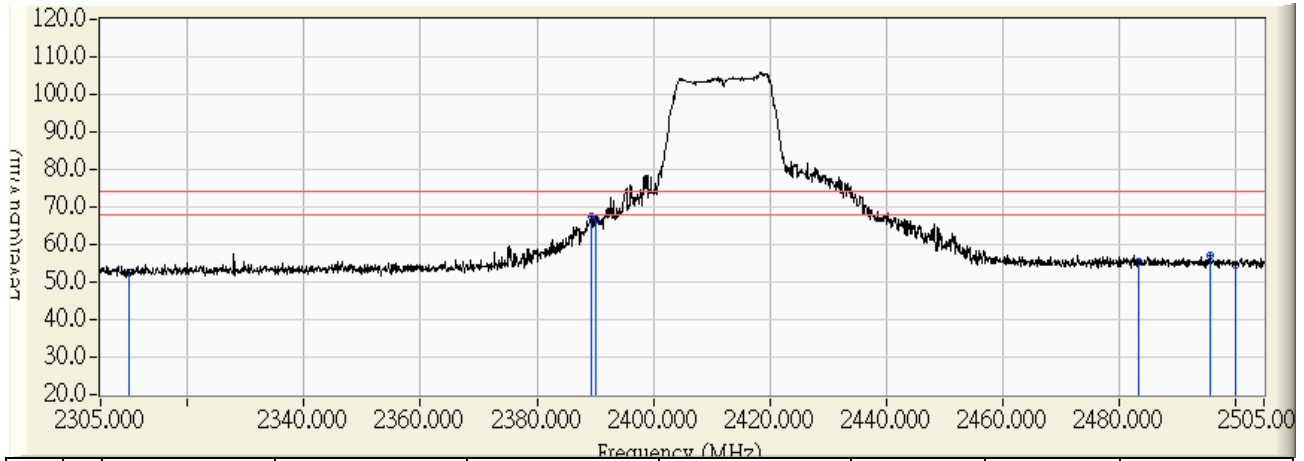

	Frequency (MHz)	Correct Factor (dB)	Reading Level (dBuV)	Measure Level (dBuV/m)	Margin (dB)	Limit (dBuV/m)	Detector Type
1	2310.000	30.411	22.157	52.568	-21.432	74.000	PEAK
2	* 2389.400	31.234	36.282	67.517	-6.483	74.000	PEAK
3	2390.000	31.241	35.304	66.545	-7.455	74.000	PEAK
4	2483.500	31.980	23.404	55.383	-18.617	74.000	PEAK
5	2495.700	31.946	25.109	57.055	-16.945	74.000	PEAK
6	2500.000	31.934	22.786	54.721	-19.279	74.000	PEAK

**Note:**

1. All readings above 1GHz are performed with peak and/or average measurements as necessary.
2. Peak measurements: RBW = 1MHz, VBW = 3 MHz, Sweep: Auto.
3. Average measurements: RBW = 1MHz, VBW = 10 Hz, Sweep: Auto.
4. “ \* ”, means this data is the worst emission level.
5. Measurement Level = Reading Level + Correct Factor.
6. The average measurement was not performed when the peak measured data under the limit of average detection.

Site : CB1	Time : 2014/08/14 - 16:28
Limit : FCC_SpartC_15.209_03M_AV	Margin : 6
Probe : CB1_FCC_EFS_1-18G-1_0901 - HORIZONTAL	Power : AC 120V/60Hz
EUT : WIFI HD BABY CAM	Note : 802.11g_CH01

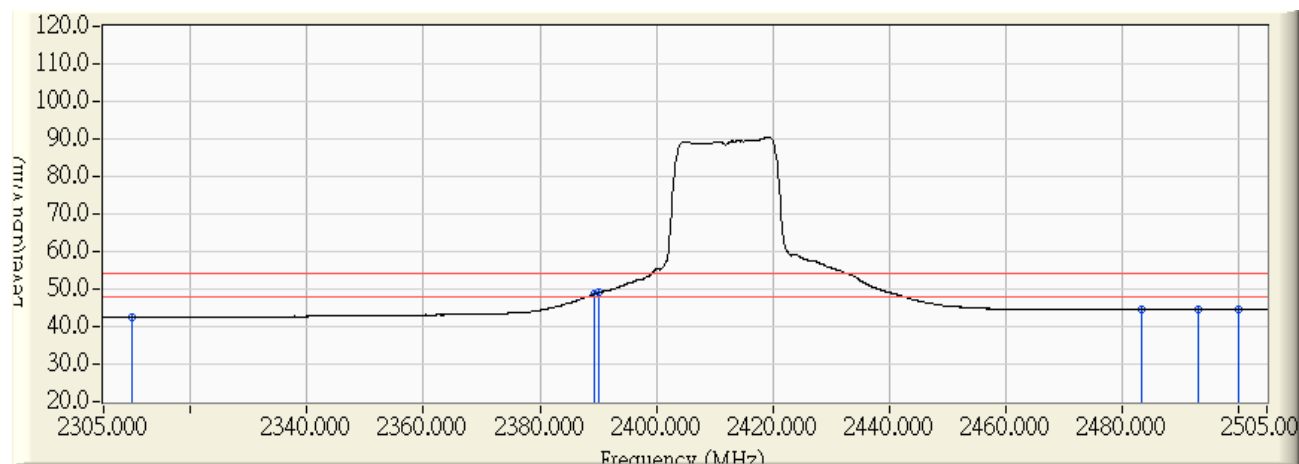

	Frequency (MHz)	Correct Factor (dB)	Reading Level (dBuV)	Measure Level (dBuV/m)	Margin (dB)	Limit (dBuV/m)	Detector Type
1	2310.000	30.411	11.946	42.357	-11.643	54.000	AVERAGE
2	2389.300	31.233	17.347	48.581	-5.419	54.000	AVERAGE
3	* 2390.000	31.241	17.754	48.995	-5.005	54.000	AVERAGE
4	2483.500	31.980	12.522	44.501	-9.499	54.000	AVERAGE
5	2493.100	31.954	12.566	44.519	-9.481	54.000	AVERAGE
6	2500.000	31.934	12.538	44.473	-9.527	54.000	AVERAGE

**Note:**

1. All readings above 1GHz are performed with peak and/or average measurements as necessary.
2. Peak measurements: RBW = 1MHz, VBW = 3 MHz, Sweep: Auto.
3. Average measurements: RBW = 1MHz, VBW = 10 Hz, Sweep: Auto.
4. “ \* ”, means this data is the worst emission level.
5. Measurement Level = Reading Level + Correct Factor.
6. The average measurement was not performed when the peak measured data under the limit of average detection.

Site : CB1	Time : 2014/08/14 - 16:22
Limit : FCC_SpartC_15.209_03M_PK	Margin : 6
Probe : CB1_FCC_EFS_1-18G-1_0901 - VERTICAL	Power : AC 120V/60Hz
EUT : WIFI HD BABY CAM	Note : 802.11g_CH01

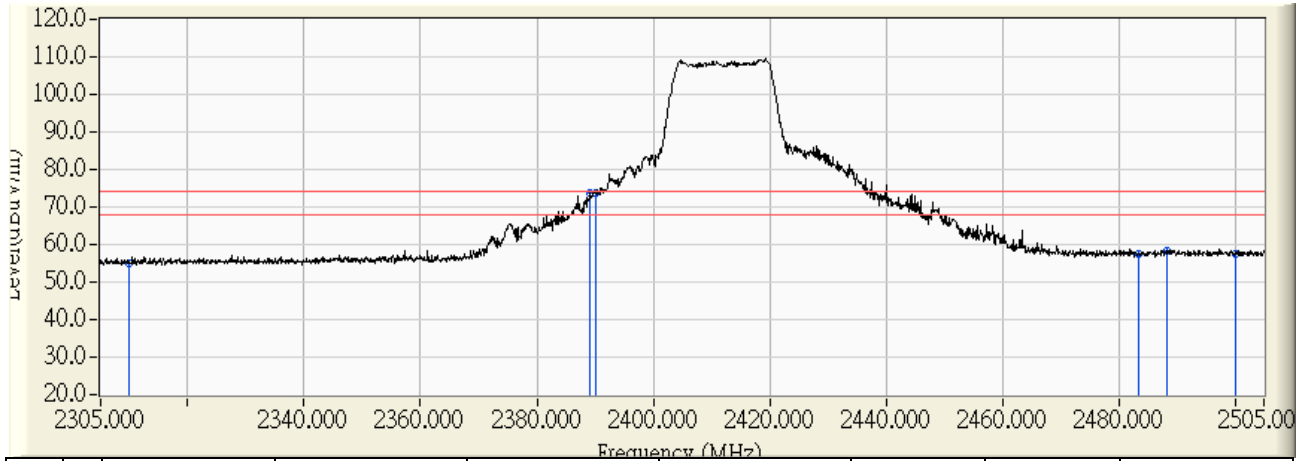

	Frequency (MHz)	Correct Factor (dB)	Reading Level (dBuV)	Measure Level (dBuV/m)	Margin (dB)	Limit (dBuV/m)	Detector Type
1	2310.000	30.411	24.513	54.924	-19.076	74.000	PEAK
2	2389.200	31.232	42.318	73.551	-0.449	74.000	PEAK
3	* 2390.000	31.241	42.696	73.937	-0.063	74.000	PEAK
4	2483.500	31.980	25.611	57.590	-16.410	74.000	PEAK
5	2488.300	31.966	26.237	58.203	-15.797	74.000	PEAK
6	2500.000	31.934	25.624	57.559	-16.441	74.000	PEAK

**Note:**

1. All readings above 1GHz are performed with peak and/or average measurements as necessary.
2. Peak measurements: RBW = 1MHz, VBW = 3 MHz, Sweep: Auto.
3. Average measurements: RBW = 1MHz, VBW = 10 Hz, Sweep: Auto.
4. “ \* ”, means this data is the worst emission level.
5. Measurement Level = Reading Level + Correct Factor.
6. The average measurement was not performed when the peak measured data under the limit of average detection.

Site : CB1	Time : 2014/08/14 - 16:24
Limit : FCC_SpartC_15.209_03M_AV	Margin : 6
Probe : CB1_FCC_EFS_1-18G-1_0901 - VERTICAL	Power : AC 120V/60Hz
EUT : WIFI HD BABY CAM	Note : 802.11g_CH01

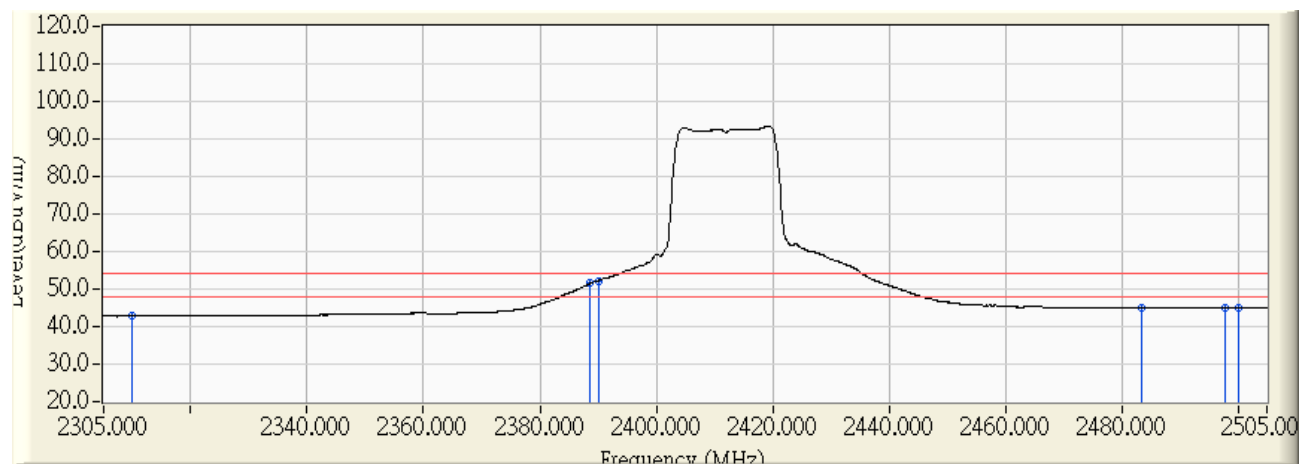

	Frequency (MHz)	Correct Factor (dB)	Reading Level (dBuV)	Measure Level (dBuV/m)	Margin (dB)	Limit (dBuV/m)	Detector Type
1	2310.000	30.411	12.354	42.765	-11.235	54.000	AVERAGE
2	2388.700	31.228	20.249	51.476	-2.524	54.000	AVERAGE
3	* 2390.000	31.241	21.042	52.283	-1.717	54.000	AVERAGE
4	2483.500	31.980	13.001	44.980	-9.020	54.000	AVERAGE
5	2497.700	31.941	13.048	44.989	-9.011	54.000	AVERAGE
6	2500.000	31.934	12.991	44.926	-9.074	54.000	AVERAGE

**Note:**

1. All readings above 1GHz are performed with peak and/or average measurements as necessary.
2. Peak measurements: RBW = 1MHz, VBW = 3 MHz, Sweep: Auto.
3. Average measurements: RBW = 1MHz, VBW = 10 Hz, Sweep: Auto.
4. “ \* ”, means this data is the worst emission level.
5. Measurement Level = Reading Level + Correct Factor.
6. The average measurement was not performed when the peak measured data under the limit of average detection.

Site : CB1	Time : 2014/08/14 - 16:55
Limit : FCC_SpartC_15.209_03M_PK	Margin : 6
Probe : CB1_FCC_EFS_1-18G-1_0901 - HORIZONTAL	Power : AC 120V/60Hz
EUT : WIFI HD BABY CAM	Note : 802.11g_CH11

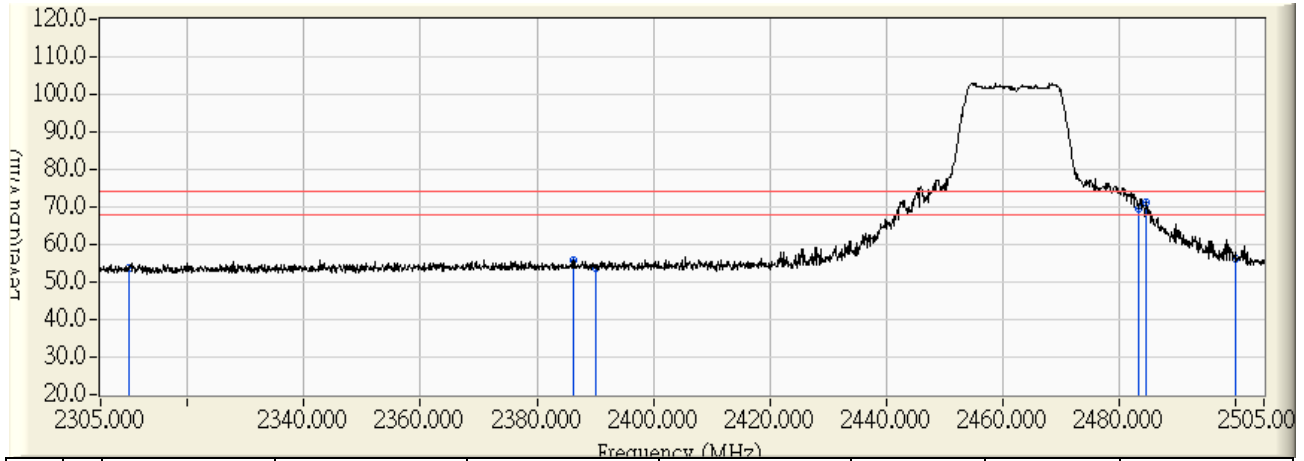

	Frequency (MHz)	Correct Factor (dB)	Reading Level (dBuV)	Measure Level (dBuV/m)	Margin (dB)	Limit (dBuV/m)	Detector Type
1	2310.000	30.411	23.286	53.697	-20.303	74.000	PEAK
2	2386.200	31.202	24.638	55.840	-18.160	74.000	PEAK
3	2390.000	31.241	22.590	53.831	-20.169	74.000	PEAK
4	2483.500	31.980	37.789	69.768	-4.232	74.000	PEAK
5	* 2484.700	31.976	39.480	71.456	-2.544	74.000	PEAK
6	2500.000	31.934	24.383	56.318	-17.682	74.000	PEAK

**Note:**

1. All readings above 1GHz are performed with peak and/or average measurements as necessary.
2. Peak measurements: RBW = 1MHz, VBW = 3 MHz, Sweep: Auto.
3. Average measurements: RBW = 1MHz, VBW = 10 Hz, Sweep: Auto.
4. “ \* ”, means this data is the worst emission level.
5. Measurement Level = Reading Level + Correct Factor.
6. The average measurement was not performed when the peak measured data under the limit of average detection.

Site : CB1	Time : 2014/08/14 - 16:56
Limit : FCC_SpartC_15.209_03M_AV	Margin : 6
Probe : CB1_FCC_EFS_1-18G-1_0901 - HORIZONTAL	Power : AC 120V/60Hz
EUT : WIFI HD BABY CAM	Note : 802.11g_CH11

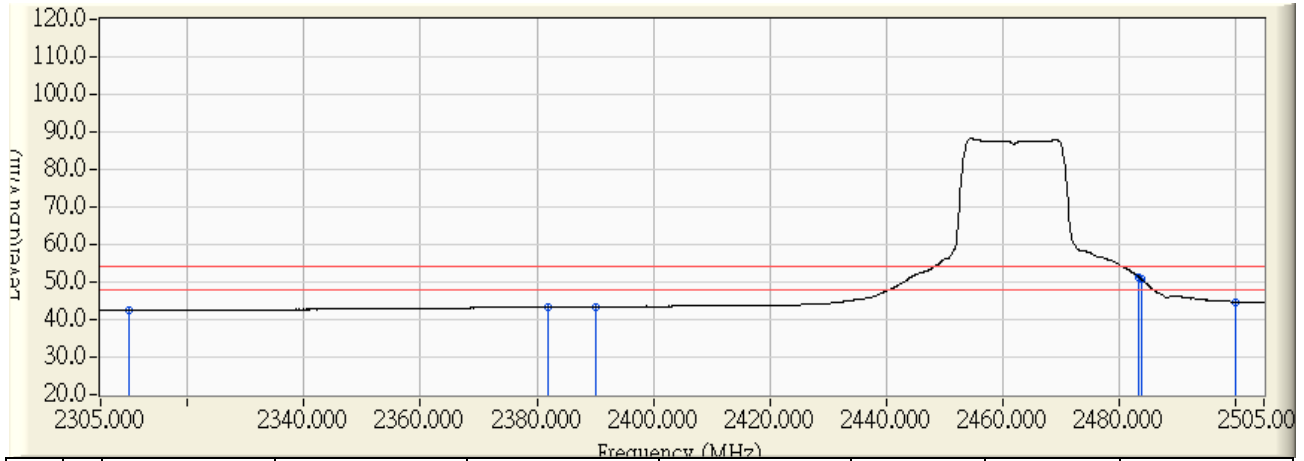

	Frequency (MHz)	Correct Factor (dB)	Reading Level (dBuV)	Measure Level (dBuV/m)	Margin (dB)	Limit (dBuV/m)	Detector Type
1	2310.000	30.411	11.982	42.393	-11.607	54.000	AVERAGE
2	2381.800	31.156	12.173	43.329	-10.671	54.000	AVERAGE
3	2390.000	31.241	12.191	43.432	-10.568	54.000	AVERAGE
4	* 2483.500	31.980	19.364	51.343	-2.657	54.000	AVERAGE
5	2483.900	31.978	18.763	50.741	-3.259	54.000	AVERAGE
6	2500.000	31.934	12.795	44.730	-9.270	54.000	AVERAGE

**Note:**

1. All readings above 1GHz are performed with peak and/or average measurements as necessary.
2. Peak measurements: RBW = 1MHz, VBW = 3 MHz, Sweep: Auto.
3. Average measurements: RBW = 1MHz, VBW = 10 Hz, Sweep: Auto.
4. “ \* ”, means this data is the worst emission level.
5. Measurement Level = Reading Level + Correct Factor.
6. The average measurement was not performed when the peak measured data under the limit of average detection.

Site : CB1	Time : 2014/08/14 - 16:50
Limit : FCC_SpartC_15.209_03M_PK	Margin : 6
Probe : CB1_FCC_EFS_1-18G-1_0901 - VERTICAL	Power : AC 120V/60Hz
EUT : WIFI HD BABY CAM	Note : 802.11g_CH11

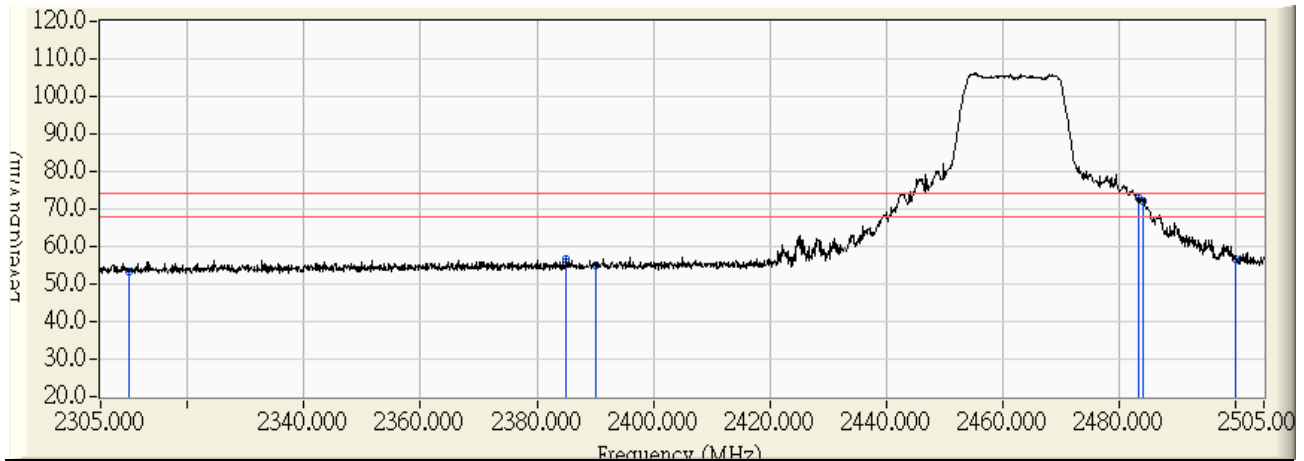

	Frequency (MHz)	Correct Factor (dB)	Reading Level (dBuV)	Measure Level (dBuV/m)	Margin (dB)	Limit (dBuV/m)	Detector Type
1	2310.000	30.411	22.761	53.172	-20.828	74.000	PEAK
2	2385.100	31.190	25.314	56.504	-17.496	74.000	PEAK
3	2390.000	31.241	23.660	54.901	-19.099	74.000	PEAK
4	* 2483.500	31.980	40.778	72.757	-1.243	74.000	PEAK
5	2484.200	31.977	40.039	72.017	-1.983	74.000	PEAK
6	2500.000	31.934	24.564	56.499	-17.501	74.000	PEAK

**Note:**

1. All readings above 1GHz are performed with peak and/or average measurements as necessary.
2. Peak measurements: RBW = 1MHz, VBW = 3 MHz, Sweep: Auto.
3. Average measurements: RBW = 1MHz, VBW = 10 Hz, Sweep: Auto.
4. “ \* ”, means this data is the worst emission level.
5. Measurement Level = Reading Level + Correct Factor.
6. The average measurement was not performed when the peak measured data under the limit of average detection.

Limit : FCC_SpartC_15.209_03M_AV	Margin : 6
Probe : CB1_FCC_EFS_1-18G-1_0901 - VERTICAL	Power : AC 120V/60Hz
EUT : WIFI HD BABY CAM	Note : 802.11g_CH11

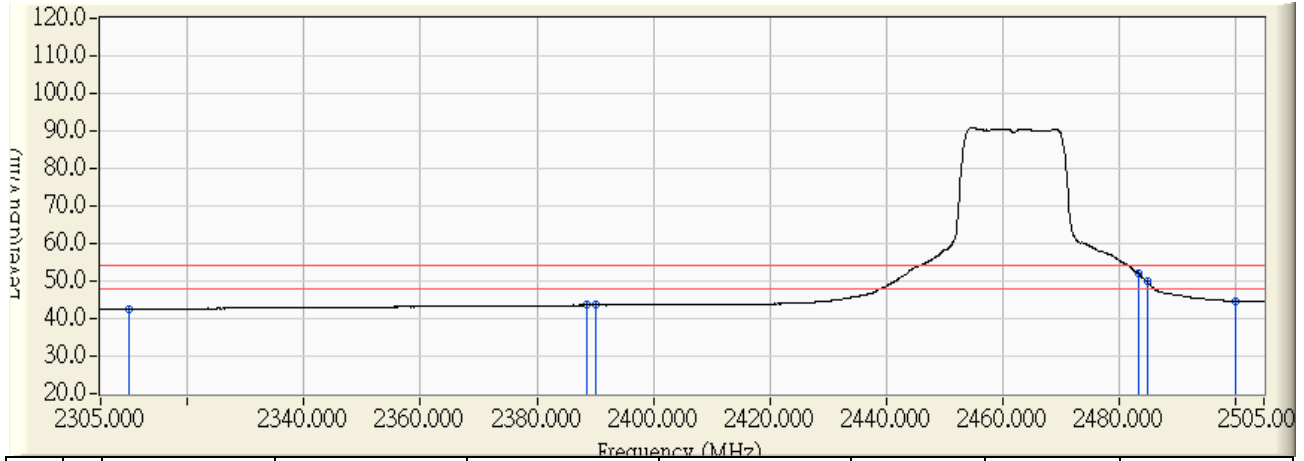

	Frequency (MHz)	Correct Factor (dB)	Reading Level (dBuV)	Measure Level (dBuV/m)	Margin (dB)	Limit (dBuV/m)	Detector Type
1	2310.000	30.411	12.124	42.535	-11.465	54.000	AVERAGE
2	2388.500	31.225	12.346	43.571	-10.429	54.000	AVERAGE
3	2390.000	31.241	12.333	43.574	-10.426	54.000	AVERAGE
4	* 2483.500	31.980	19.948	51.927	-2.073	54.000	AVERAGE
5	2484.900	31.976	17.854	49.830	-4.170	54.000	AVERAGE
6	2500.000	31.934	12.728	44.663	-9.337	54.000	AVERAGE

**Note:**

1. All readings above 1GHz are performed with peak and/or average measurements as necessary.
2. Peak measurements: RBW = 1MHz, VBW = 3 MHz, Sweep: Auto.
3. Average measurements: RBW = 1MHz, VBW = 10 Hz, Sweep: Auto.
4. “ \* ”, means this data is the worst emission level.
5. Measurement Level = Reading Level + Correct Factor.
6. The average measurement was not performed when the peak measured data under the limit of average detection.



Site : CB1	Time : 2014/08/14 - 17:14
Limit : FCC_SpartC_15.209_03M_PK	Margin : 6
Probe : CB1_FCC_EFS_1-18G-1_0901 - HORIZONTAL	Power : AC 120V/60Hz
EUT : WIFI HD BABY CAM	Note : 802.11n 20MHz_CH01

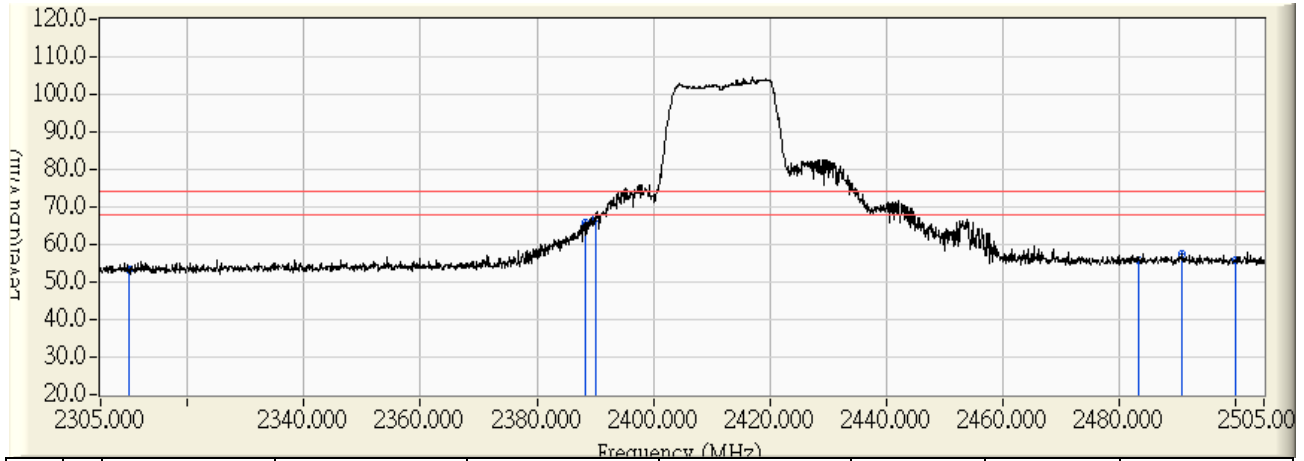

	Frequency (MHz)	Correct Factor (dB)	Reading Level (dBuV)	Measure Level (dBuV/m)	Margin (dB)	Limit (dBuV/m)	Detector Type
1	2310.000	30.411	22.967	53.378	-20.622	74.000	PEAK
2	2388.300	31.223	34.481	65.704	-8.296	74.000	PEAK
3	* 2390.000	31.241	35.694	66.935	-7.065	74.000	PEAK
4	2483.500	31.980	23.919	55.898	-18.102	74.000	PEAK
5	2491.000	31.959	25.641	57.600	-16.400	74.000	PEAK
6	2500.000	31.934	23.761	55.696	-18.304	74.000	PEAK

**Note:**

1. All readings above 1GHz are performed with peak and/or average measurements as necessary.
2. Peak measurements: RBW = 1MHz, VBW = 3 MHz, Sweep: Auto.
3. Average measurements: RBW = 1MHz, VBW = 10 Hz, Sweep: Auto.
4. “ \* ”, means this data is the worst emission level.
5. Measurement Level = Reading Level + Correct Factor.
6. The average measurement was not performed when the peak measured data under the limit of average detection.

Site : CB1	Time : 2014/08/14 - 17:15
Limit : FCC_SpartC_15.209_03M_AV	Margin : 6
Probe : CB1_FCC_EFS_1-18G-1_0901 - HORIZONTAL	Power : AC 120V/60Hz
EUT : WIFI HD BABY CAM	Note : 802.11n 20MHz_CH01

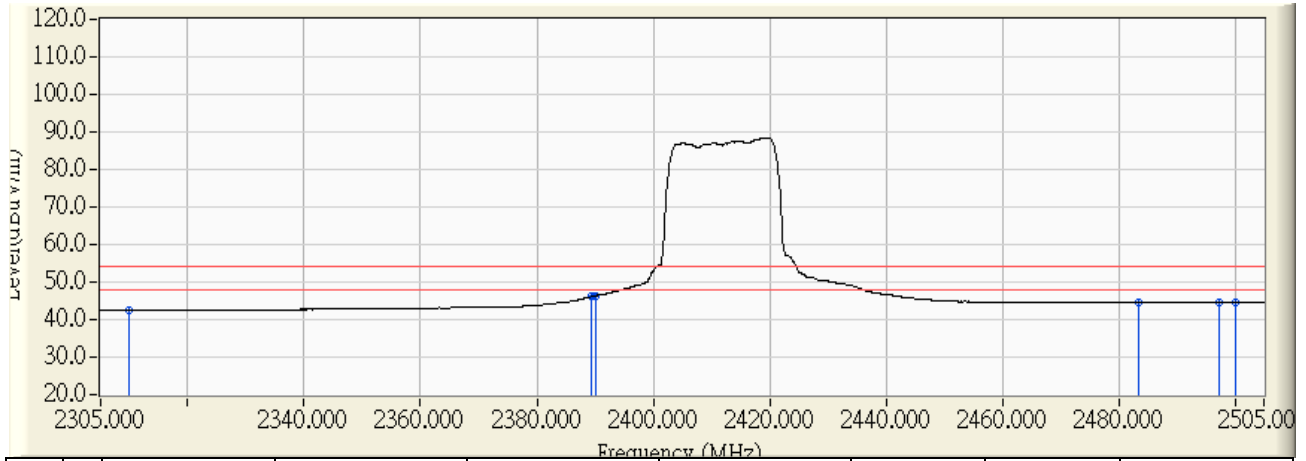

	Frequency (MHz)	Correct Factor (dB)	Reading Level (dBuV)	Measure Level (dBuV/m)	Margin (dB)	Limit (dBuV/m)	Detector Type
1	2310.000	30.411	11.951	42.362	-11.638	54.000	AVERAGE
2	2389.300	31.233	14.840	46.074	-7.926	54.000	AVERAGE
3	* 2390.000	31.241	15.029	46.270	-7.730	54.000	AVERAGE
4	2483.500	31.980	12.681	44.660	-9.340	54.000	AVERAGE
5	2497.200	31.942	12.700	44.642	-9.358	54.000	AVERAGE
6	2500.000	31.934	12.620	44.555	-9.445	54.000	AVERAGE

**Note:**

1. All readings above 1GHz are performed with peak and/or average measurements as necessary.
2. Peak measurements: RBW = 1MHz, VBW = 3 MHz, Sweep: Auto.
3. Average measurements: RBW = 1MHz, VBW = 10 Hz, Sweep: Auto.
4. “ \* ”, means this data is the worst emission level.
5. Measurement Level = Reading Level + Correct Factor.
6. The average measurement was not performed when the peak measured data under the limit of average detection.

Site : CB1	Time : 2014/08/14 - 17:05
Limit : FCC_SpartC_15.209_03M_PK	Margin : 6
Probe : CB1_FCC_EFS_1-18G-1_0901 - VERTICAL	Power : AC 120V/60Hz
EUT : WIFI HD BABY CAM	Note : 802.11n 20MHz_CH01

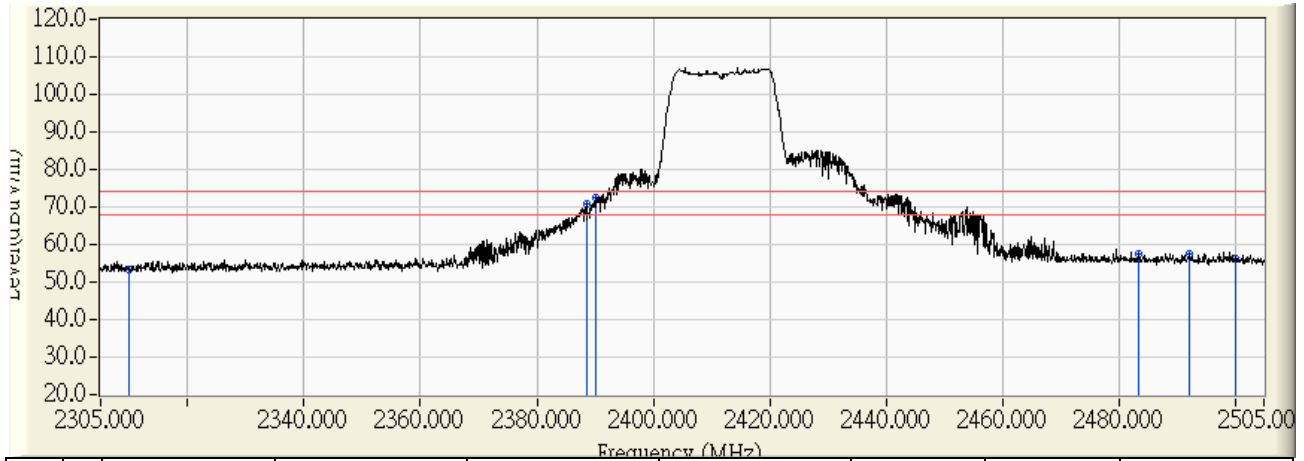

	Frequency (MHz)	Correct Factor (dB)	Reading Level (dBuV)	Measure Level (dBuV/m)	Margin (dB)	Limit (dBuV/m)	Detector Type
1	2310.000	30.411	22.778	53.189	-20.811	74.000	PEAK
2	2388.500	31.225	39.659	70.884	-3.116	74.000	PEAK
3	* 2390.000	31.241	41.077	72.318	-1.682	74.000	PEAK
4	2483.500	31.980	25.379	57.358	-16.642	74.000	PEAK
5	2492.100	31.956	25.426	57.382	-16.618	74.000	PEAK
6	2500.000	31.934	24.210	56.145	-17.855	74.000	PEAK

**Note:**

1. All readings above 1GHz are performed with peak and/or average measurements as necessary.
2. Peak measurements: RBW = 1MHz, VBW = 3 MHz, Sweep: Auto.
3. Average measurements: RBW = 1MHz, VBW = 10 Hz, Sweep: Auto.
4. “ \* ”, means this data is the worst emission level.
5. Measurement Level = Reading Level + Correct Factor.
6. The average measurement was not performed when the peak measured data under the limit of average detection.

Site : CB1	Time : 2014/08/14 - 17:06
Limit : FCC_SpartC_15.209_03M_AV	Margin : 6
Probe : CB1_FCC_EFS_1-18G-1_0901 - VERTICAL	Power : AC 120V/60Hz
EUT : WIFI HD BABY CAM	Note : 802.11n 20MHz_CH01

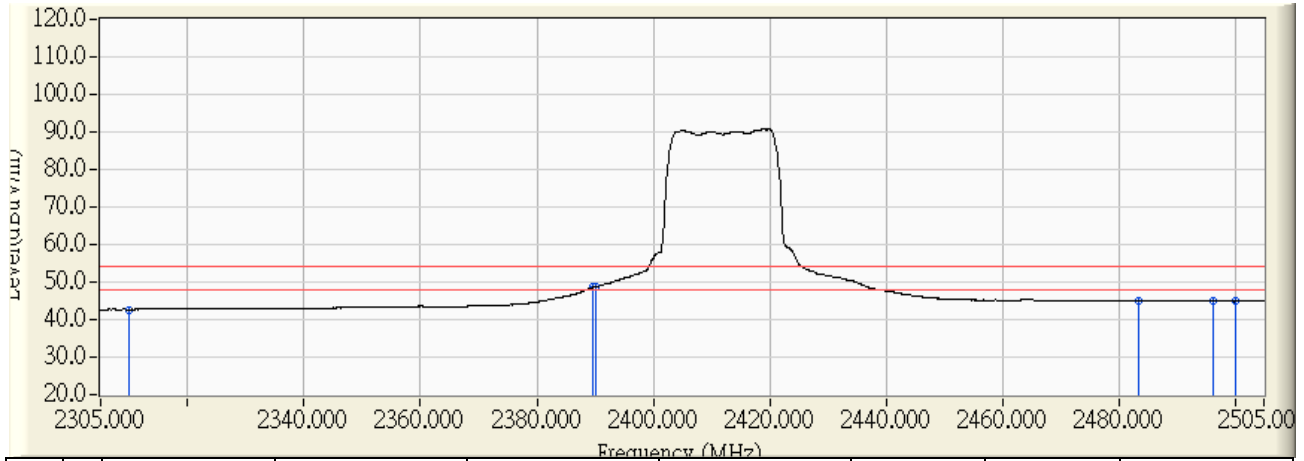

	Frequency (MHz)	Correct Factor (dB)	Reading Level (dBuV)	Measure Level (dBuV/m)	Margin (dB)	Limit (dBuV/m)	Detector Type
1	2310.000	30.411	12.282	42.693	-11.307	54.000	AVERAGE
2	2389.700	31.238	17.346	48.584	-5.416	54.000	AVERAGE
3	* 2390.000	31.241	17.403	48.644	-5.356	54.000	AVERAGE
4	2483.500	31.980	12.966	44.945	-9.055	54.000	AVERAGE
5	2496.200	31.945	12.966	44.911	-9.089	54.000	AVERAGE
6	2500.000	31.934	12.888	44.823	-9.177	54.000	AVERAGE

**Note:**

1. All readings above 1GHz are performed with peak and/or average measurements as necessary.
2. Peak measurements: RBW = 1MHz, VBW = 3 MHz, Sweep: Auto.
3. Average measurements: RBW = 1MHz, VBW = 10 Hz, Sweep: Auto.
4. “ \* ”, means this data is the worst emission level.
5. Measurement Level = Reading Level + Correct Factor.
6. The average measurement was not performed when the peak measured data under the limit of average detection.

Site : CB1	Time : 2014/08/14 - 18:20
Limit : FCC_SpartC_15.209_03M_PK	Margin : 6
Probe : CB1_FCC_EFS_1-18G-1_0901 - HORIZONTAL	Power : AC 120V/60Hz
EUT : WIFI HD BABY CAM	Note : 802.11n 20MHz_CH11

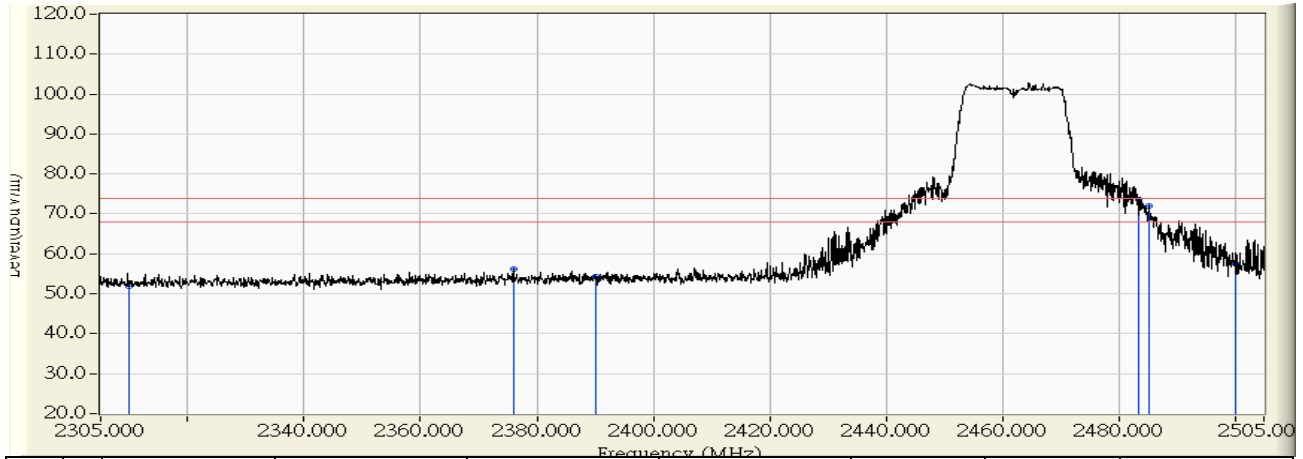

	Frequency (MHz)	Correct Factor (dB)	Reading Level (dBuV)	Measure Level (dBuV/m)	Margin (dB)	Limit (dBuV/m)	Detector Type
1	2310.000	30.411	21.504	51.915	-22.085	74.000	PEAK
2	2375.900	31.095	25.077	56.172	-17.828	74.000	PEAK
3	2390.000	31.241	23.077	54.318	-19.682	74.000	PEAK
4	* 2483.500	31.980	41.733	73.712	-0.288	74.000	PEAK
5	2485.200	31.975	39.963	71.938	-2.062	74.000	PEAK
6	2500.000	31.934	25.590	57.525	-16.475	74.000	PEAK

**Note:**

1. All readings above 1GHz are performed with peak and/or average measurements as necessary.
2. Peak measurements: RBW = 1MHz, VBW = 3 MHz, Sweep: Auto.
3. Average measurements: RBW = 1MHz, VBW = 10 Hz, Sweep: Auto.
4. “ \* ”, means this data is the worst emission level.
5. Measurement Level = Reading Level + Correct Factor.
6. The average measurement was not performed when the peak measured data under the limit of average detection.

Site : CB1	Time : 2014/08/14 - 18:21
Limit : FCC_SpartC_15.209_03M_AV	Margin : 6
Probe : CB1_FCC_EFS_1-18G-1_0901 - HORIZONTAL	Power : AC 120V/60Hz
EUT : WIFI HD BABY CAM	Note : 802.11n 20MHz_CH11

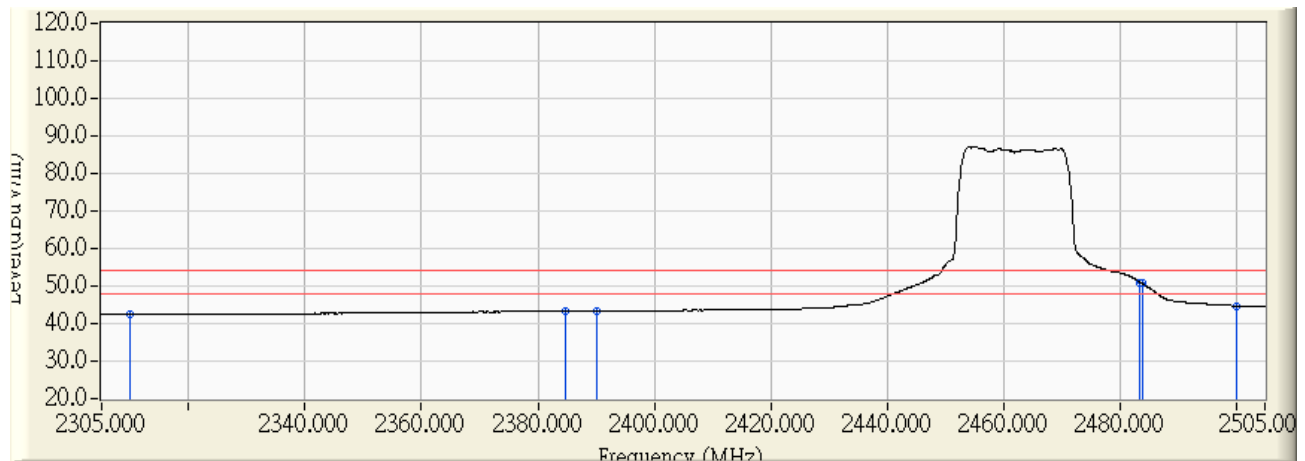

	Frequency (MHz)	Correct Factor (dB)	Reading Level (dBuV)	Measure Level (dBuV/m)	Margin (dB)	Limit (dBuV/m)	Detector Type
1	2310.000	30.411	11.961	42.372	-11.628	54.000	AVERAGE
2	2384.700	31.186	12.139	43.325	-10.675	54.000	AVERAGE
3	2390.000	31.241	12.170	43.411	-10.589	54.000	AVERAGE
4	* 2483.500	31.980	19.054	51.033	-2.967	54.000	AVERAGE
5	2483.900	31.978	18.708	50.686	-3.314	54.000	AVERAGE
6	2500.000	31.934	12.763	44.698	-9.302	54.000	AVERAGE

**Note:**

1. All readings above 1GHz are performed with peak and/or average measurements as necessary.
2. Peak measurements: RBW = 1MHz, VBW = 3 MHz, Sweep: Auto.
3. Average measurements: RBW = 1MHz, VBW = 10 Hz, Sweep: Auto.
4. “ \* ”, means this data is the worst emission level.
5. Measurement Level = Reading Level + Correct Factor.
6. The average measurement was not performed when the peak measured data under the limit of average detection.

Site : CB1	Time : 2014/08/14 - 18:14
Limit : FCC_SpartC_15.209_03M_PK	Margin : 6
Probe : CB1_FCC_EFS_1-18G-1_0901 - VERTICAL	Power : AC 120V/60Hz
EUT : WIFI HD BABY CAM	Note : 802.11n 20MHz_CH11

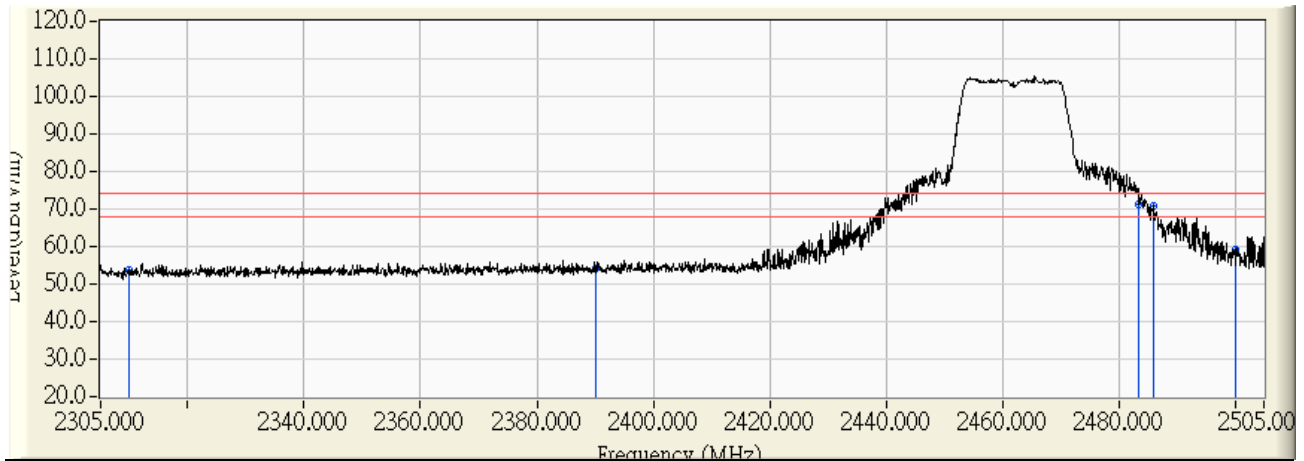

	Frequency (MHz)	Correct Factor (dB)	Reading Level (dBuV)	Measure Level (dBuV/m)	Margin (dB)	Limit (dBuV/m)	Detector Type
1	2310.000	30.411	23.345	53.756	-20.244	74.000	PEAK
2	2390.000	31.241	22.889	54.130	-19.870	74.000	PEAK
3	* 2483.500	31.980	39.393	71.372	-2.628	74.000	PEAK
4	2485.900	31.973	38.917	70.890	-3.110	74.000	PEAK
5	2500.000	31.934	27.382	59.317	-14.683	74.000	PEAK

**Note:**

1. All readings above 1GHz are performed with peak and/or average measurements as necessary.
2. Peak measurements: RBW = 1MHz, VBW = 3 MHz, Sweep: Auto.
3. Average measurements: RBW = 1MHz, VBW = 10 Hz, Sweep: Auto.
4. “ \* ”, means this data is the worst emission level.
5. Measurement Level = Reading Level + Correct Factor.
6. The average measurement was not performed when the peak measured data under the limit of average detection.

Site : CB1	Time : 2014/08/14 - 18:17
Limit : FCC_SpartC_15.209_03M_AV	Margin : 6
Probe : CB1_FCC_EFS_1-18G-1_0901 - VERTICAL	Power : AC 120V/60Hz
EUT : WIFI HD BABY CAM	Note : 802.11n 20MHz_CH11

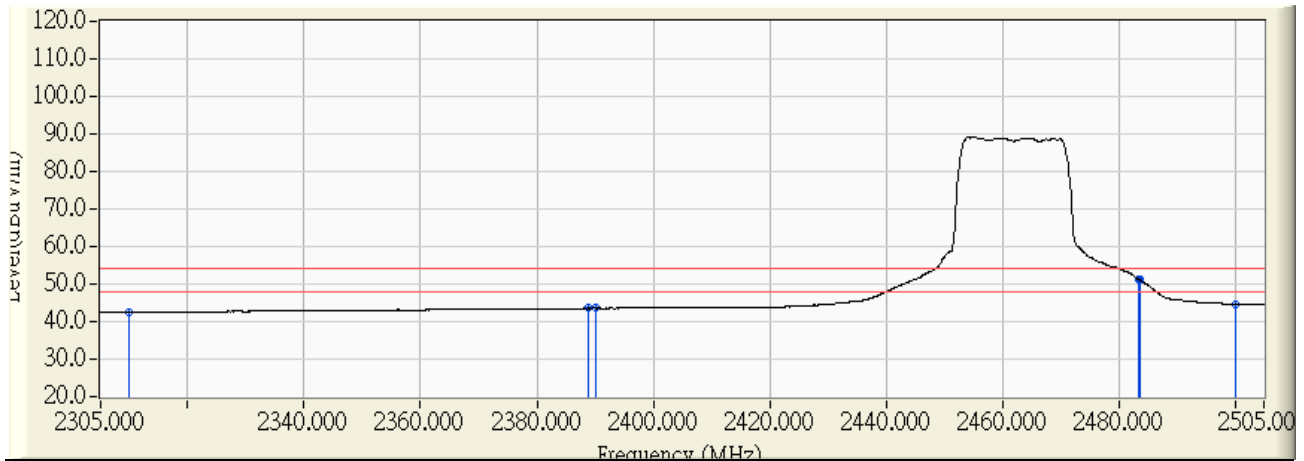

	Frequency (MHz)	Correct Factor (dB)	Reading Level (dBuV)	Measure Level (dBuV/m)	Margin (dB)	Limit (dBuV/m)	Detector Type
1	2310.000	30.411	12.067	42.478	-11.522	54.000	AVERAGE
2	2388.900	31.230	12.327	43.557	-10.443	54.000	AVERAGE
3	2390.000	31.241	12.301	43.542	-10.458	54.000	AVERAGE
4	* 2483.500	31.980	19.229	51.208	-2.792	54.000	AVERAGE
5	2483.600	31.979	19.142	51.121	-2.879	54.000	AVERAGE
6	2500.000	31.934	12.696	44.631	-9.369	54.000	AVERAGE

**Note:**

1. All readings above 1GHz are performed with peak and/or average measurements as necessary.
2. Peak measurements: RBW = 1MHz, VBW = 3 MHz, Sweep: Auto.
3. Average measurements: RBW = 1MHz, VBW = 10 Hz, Sweep: Auto.
4. “ \* ”, means this data is the worst emission level.
5. Measurement Level = Reading Level + Correct Factor.
6. The average measurement was not performed when the peak measured data under the limit of average detection.



**7. DTS Bandwidth**

**7.1. Test Equipment**

The following test equipments are used during the test:

**DTS Bandwidth / SR7**

Instrument	Manufacturer	Model No.	Serial No	Next Cal. Date
Spectrum Analyzer	Agilent	N9010A-EXA	US47140172	2015/07/14

Note: 1. All equipments that need to calibrate are with calibration period of 1 year.

**7.2. Test Setup**

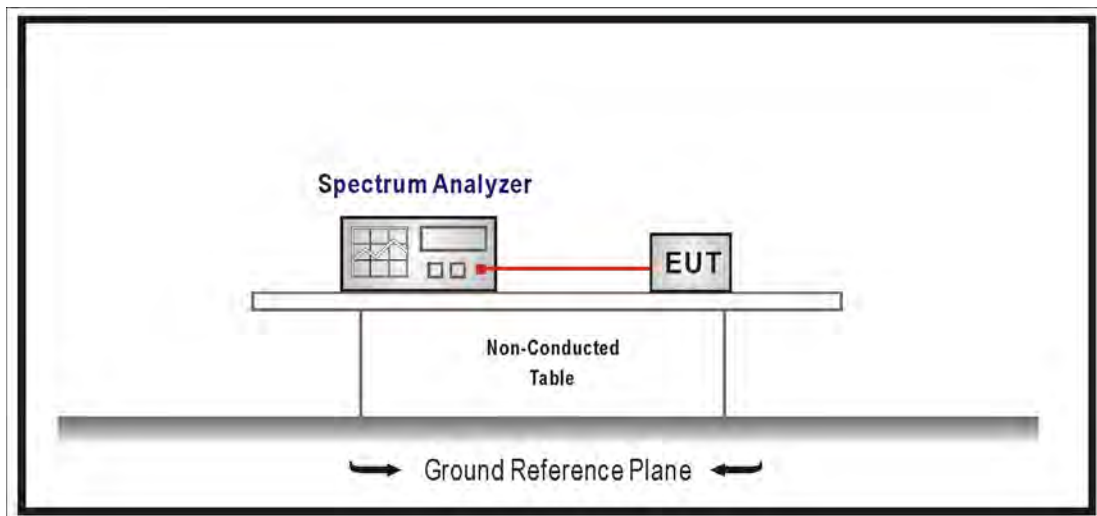

**7.3. Test Procedures**

The EUT was setup according to ANSI C63.10; tested procedure section 8.1 of KDB558074 v03r02 for compliance to FCC 47CFR 15.247 requirements. Set RBW = 100KHz, Set the VBW  $\geq 3 \times$  RBW, Sweep Time=Auto, Set Peak Detector.

**7.4. Limits**

The 6 dB bandwidth must be greater than 500 kHz.

**7.5. Test Specification**

According to FCC Part 15 Subpart C Paragraph 15.247: 2013

**7.6. Uncertainty**

The measurement uncertainty is defined as  $\pm 150$ Hz

## 7.7. Test Result

Product	WiFi HD Baby Cam		
Test Item	DTS Bandwidth		
Test Mode	Mode 1: Transmit		
Date of Test	2014/08/16	Test Site	SR7

IEEE 802.11n, ANT 0				
Channel No.	Frequency (MHz)	Measurement Level (MHz)	Required Limit (MHz)	Result
1	2412	10.08	$\geq 0.5$	Pass
6	2437	10.09	$\geq 0.5$	Pass
11	2462	10.09	$\geq 0.5$	Pass

### Channel 1

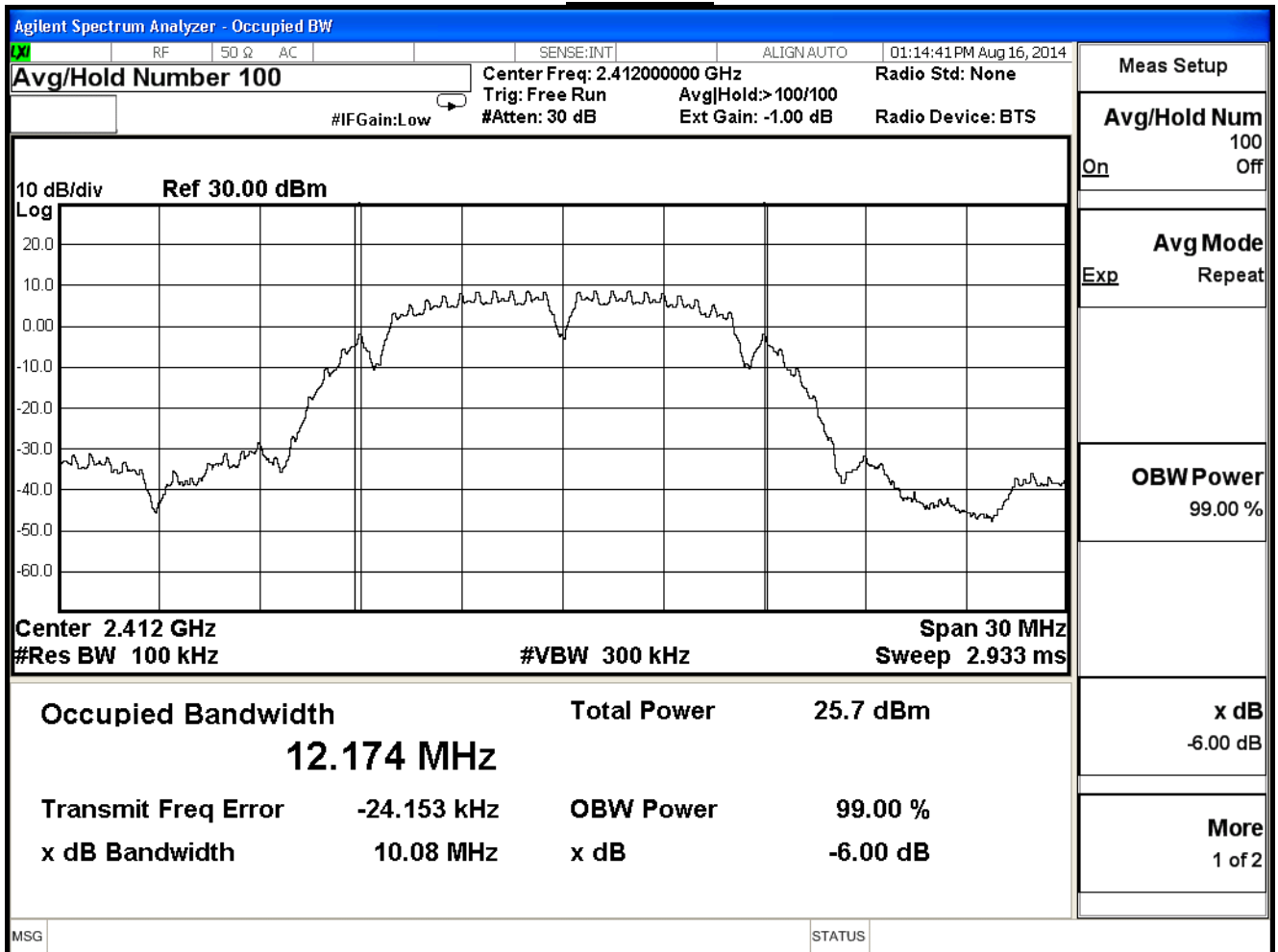

## Channel 6

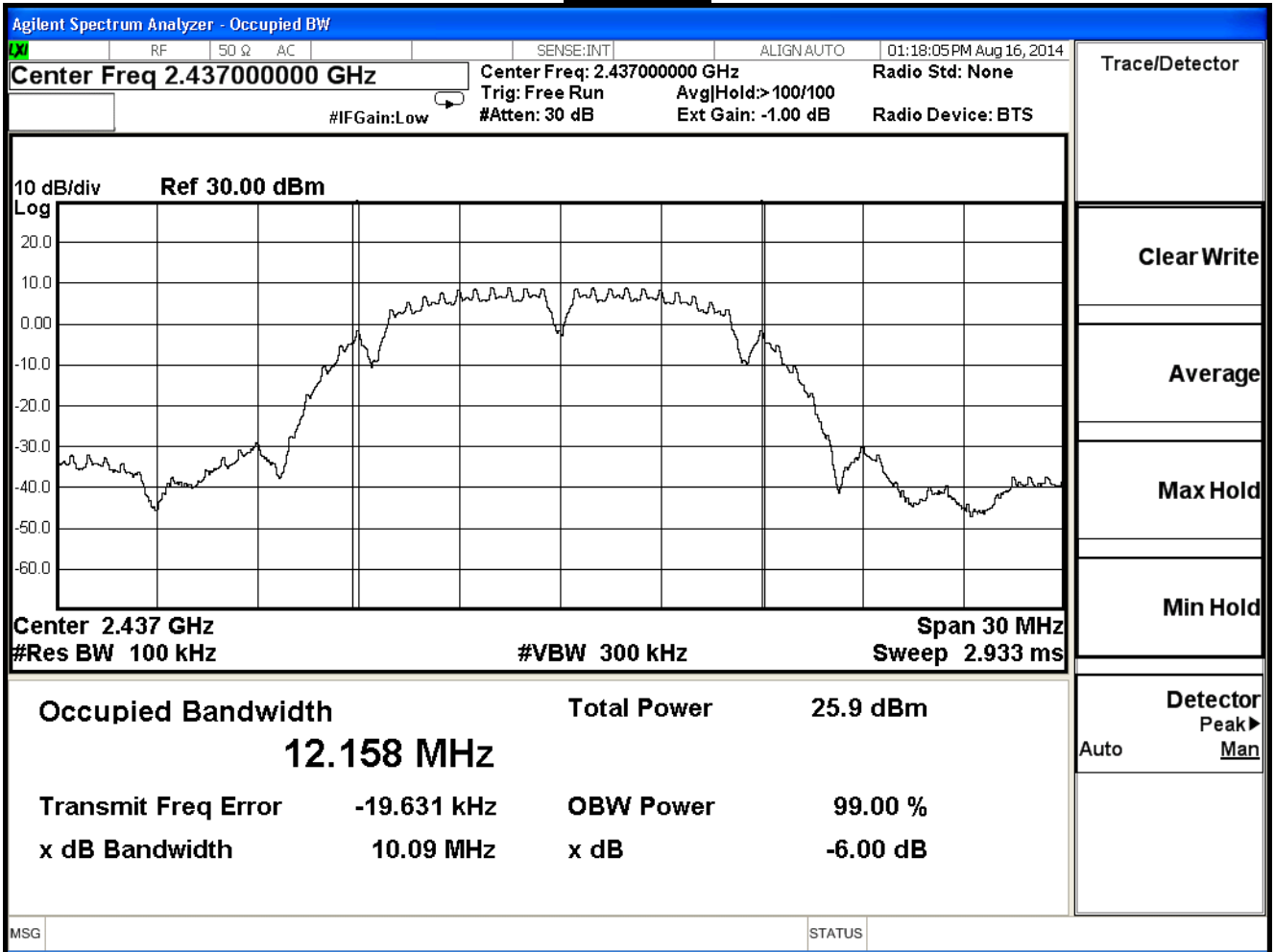

## Channel 11

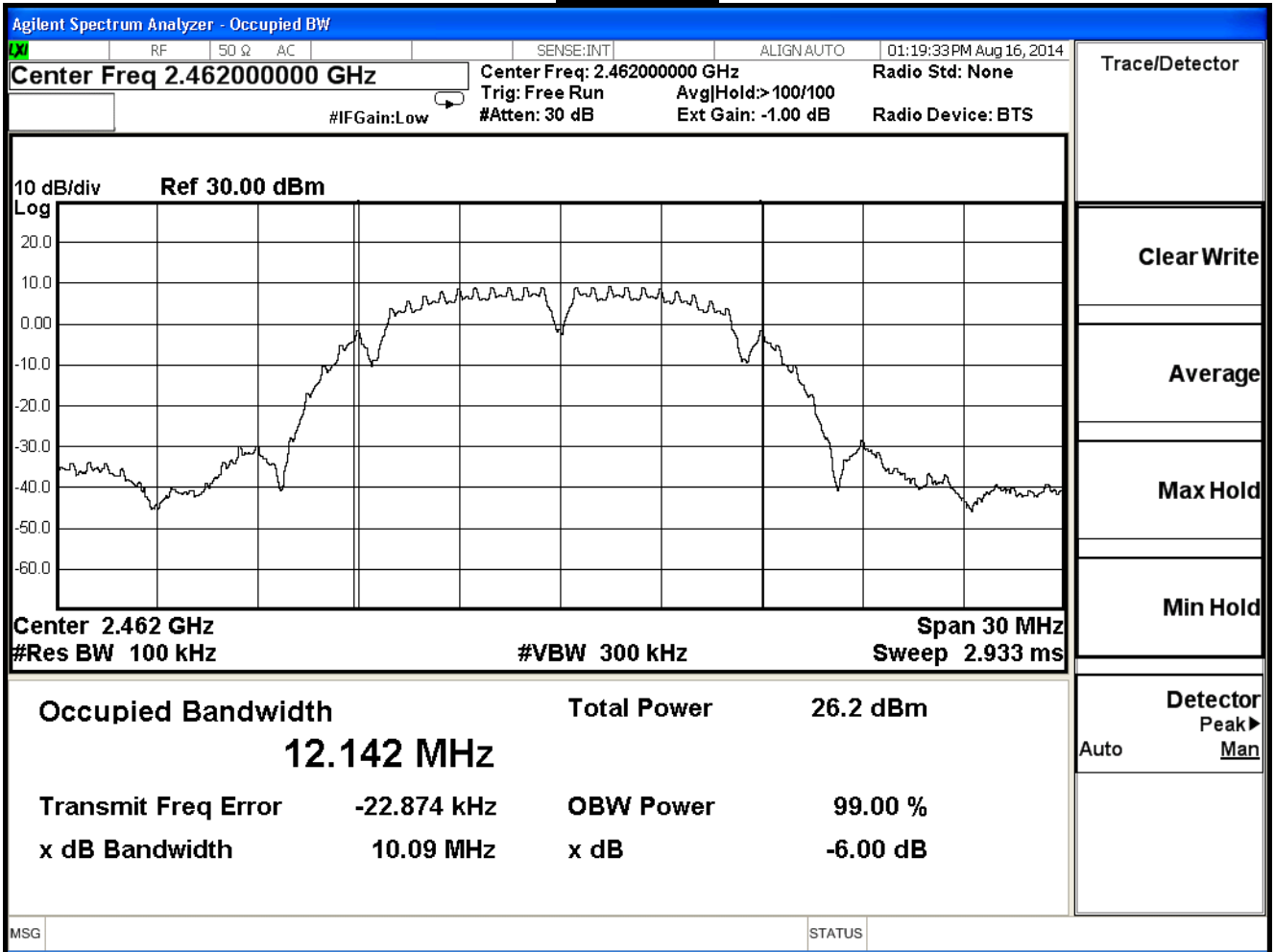

Product	WiFi HD Baby Cam		
Test Item	DTS Bandwidth		
Test Mode	Mode 1: Transmit		
Date of Test	2014/08/16	Test Site	SR7

IEEE 802.11g, ANT 0				
Channel No.	Frequency (MHz)	Measurement Level (MHz)	Required Limit (MHz)	Result
1	2412	16.40	$\geq 0.5$	Pass
6	2437	16.38	$\geq 0.5$	Pass
11	2462	16.41	$\geq 0.5$	Pass

### Channel 1

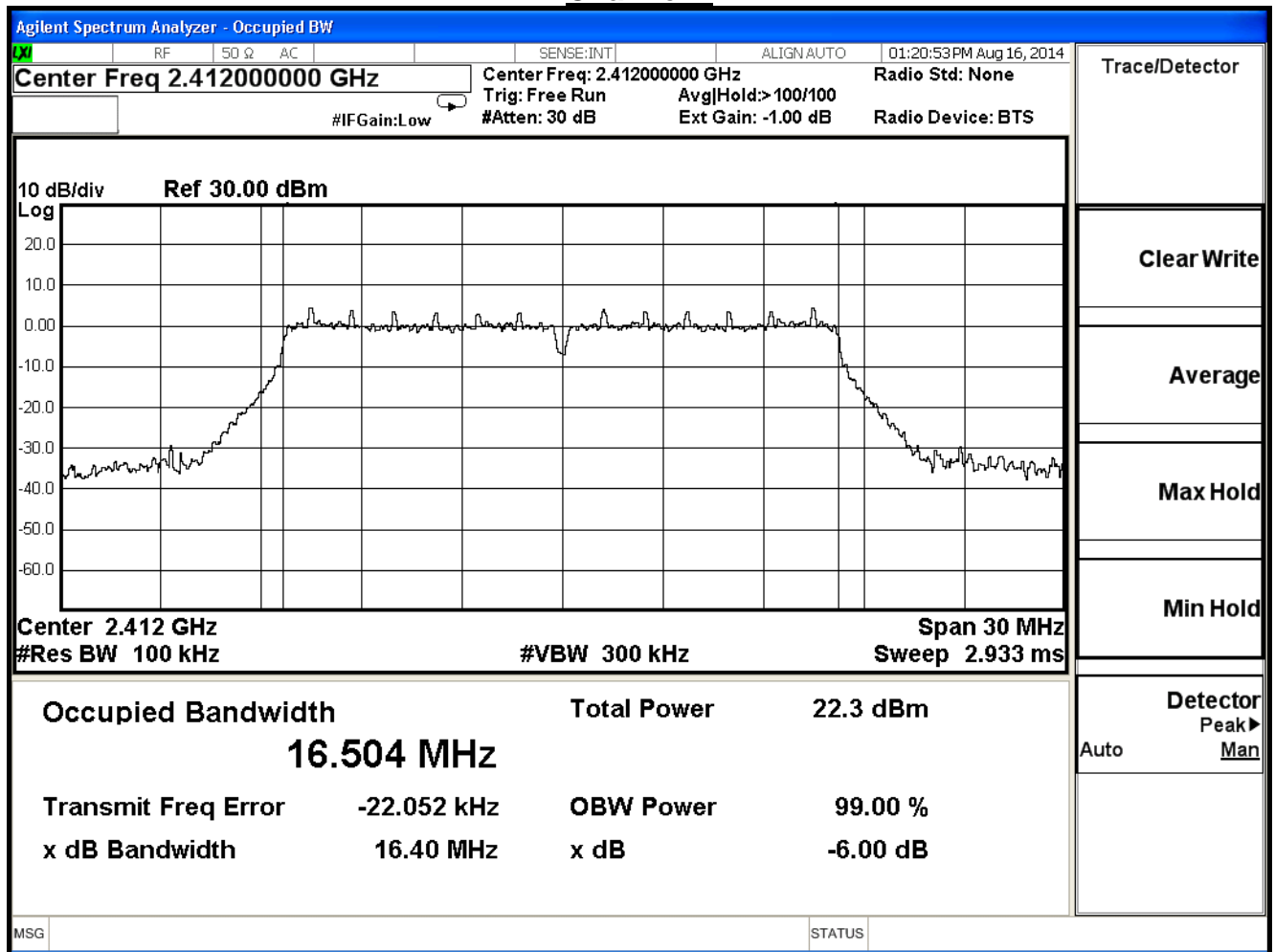

Channel 6

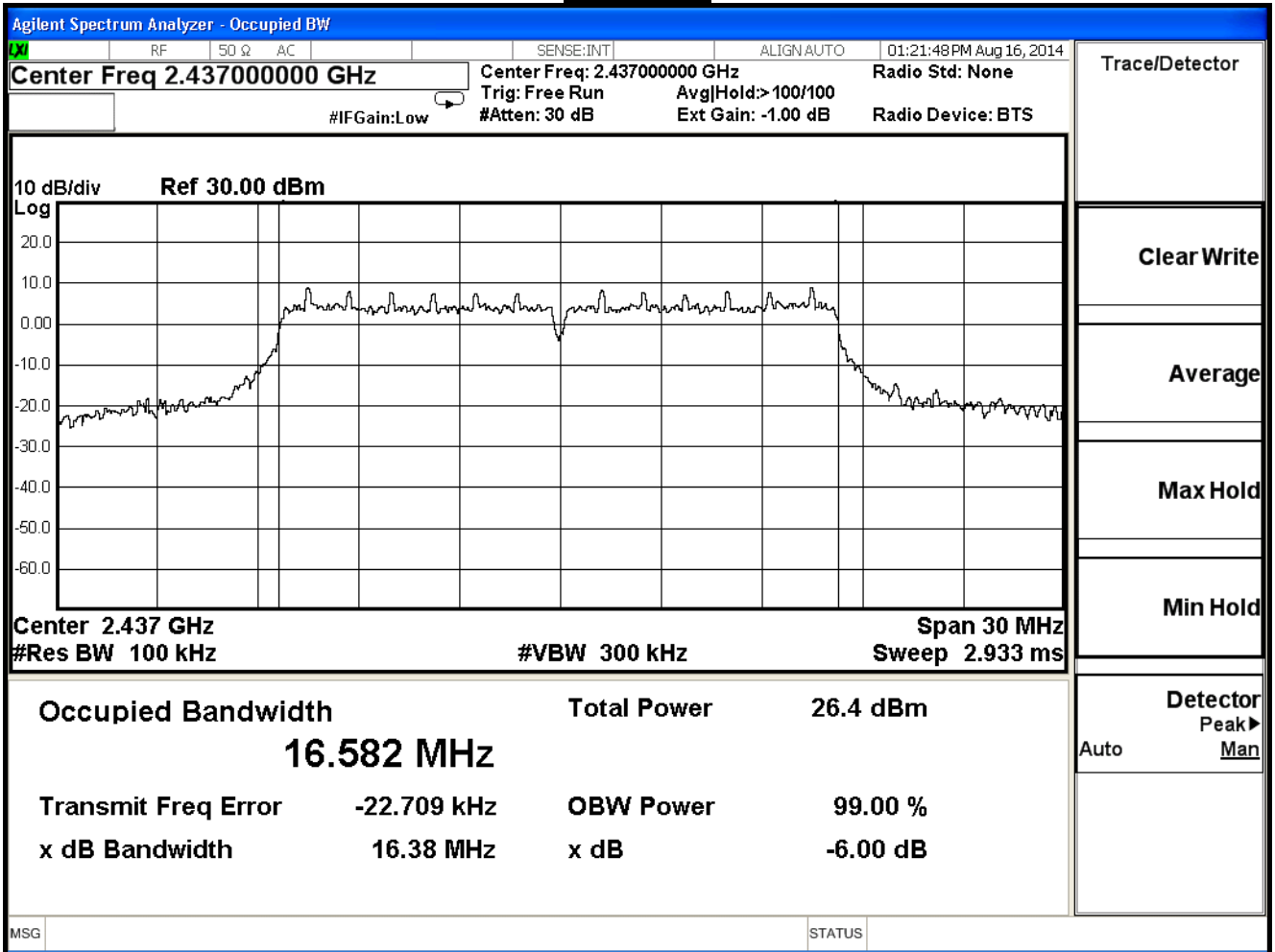

## Channel 11

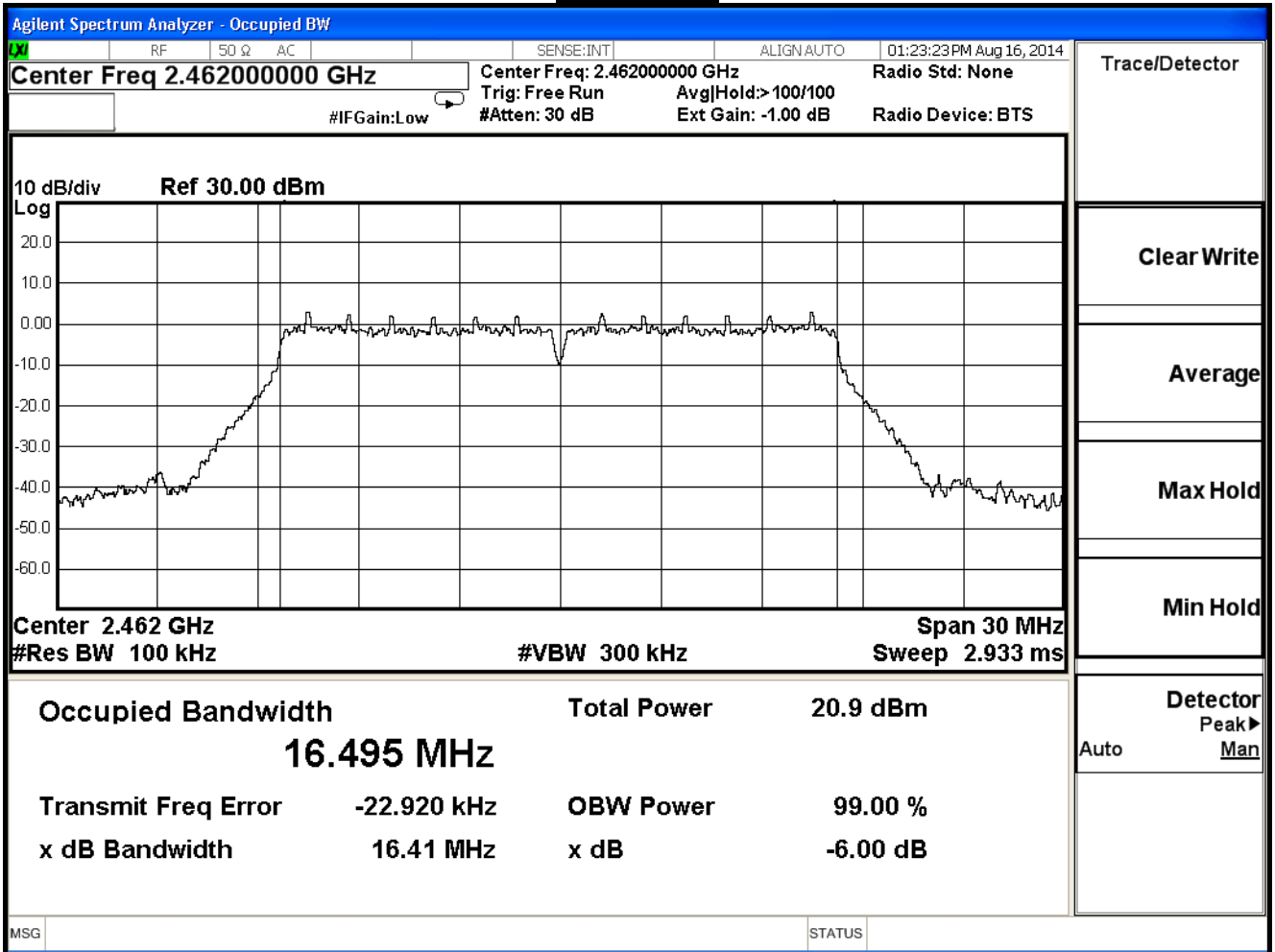

Product	WiFi HD Baby Cam		
Test Item	DTS Bandwidth		
Test Mode	Mode 1: Transmit		
Date of Test	2014/08/16	Test Site	SR7

IEEE 802.11n (20MHz), ANT 0				
Channel No.	Frequency (MHz)	Measurement Level (MHz)	Required Limit (MHz)	Result
1	2412	17.37	≥ 0.5	Pass
6	2437	17.20	≥ 0.5	Pass
11	2462	17.23	≥ 0.5	Pass

### Channel 1

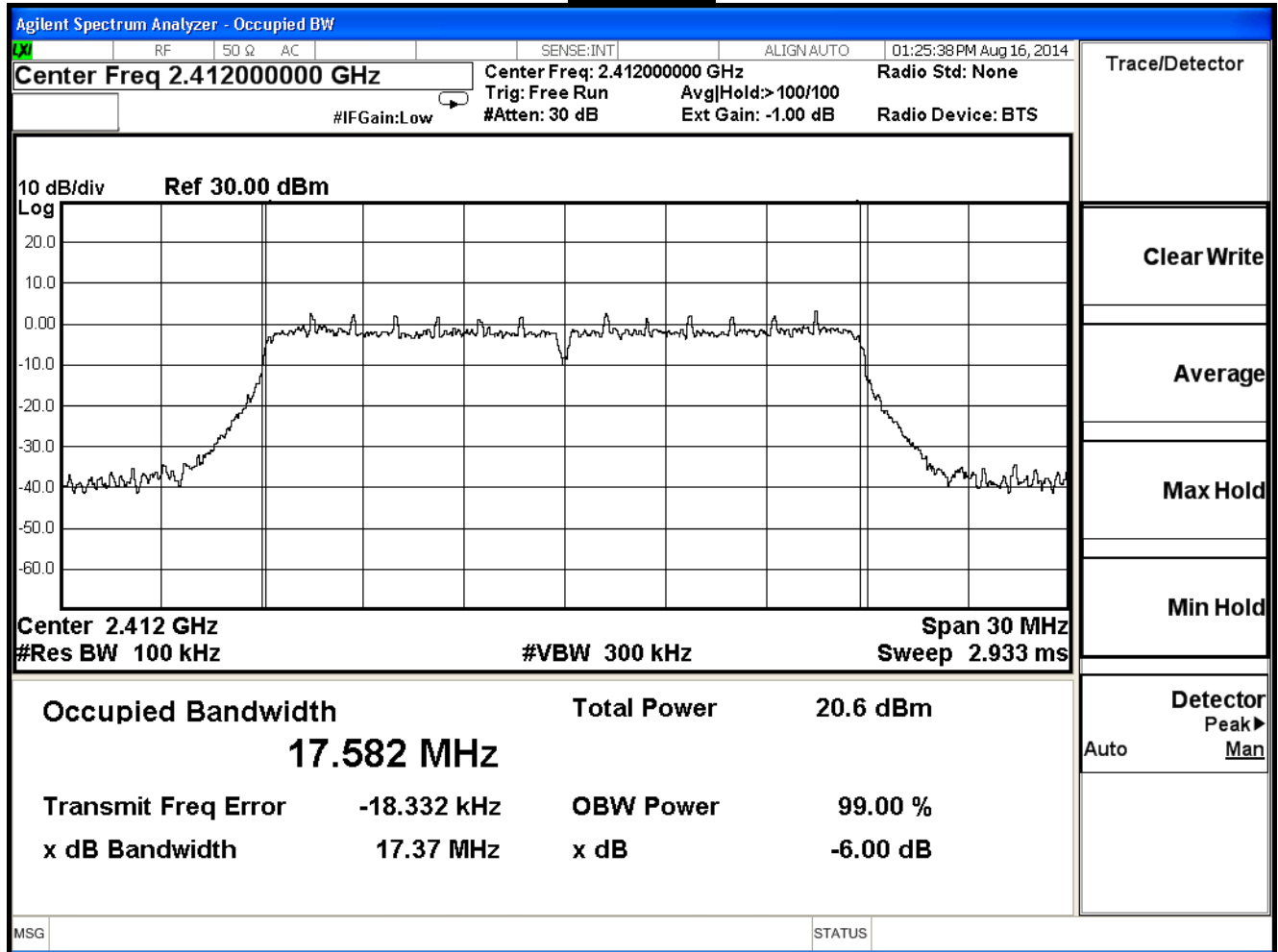



## Channel 6

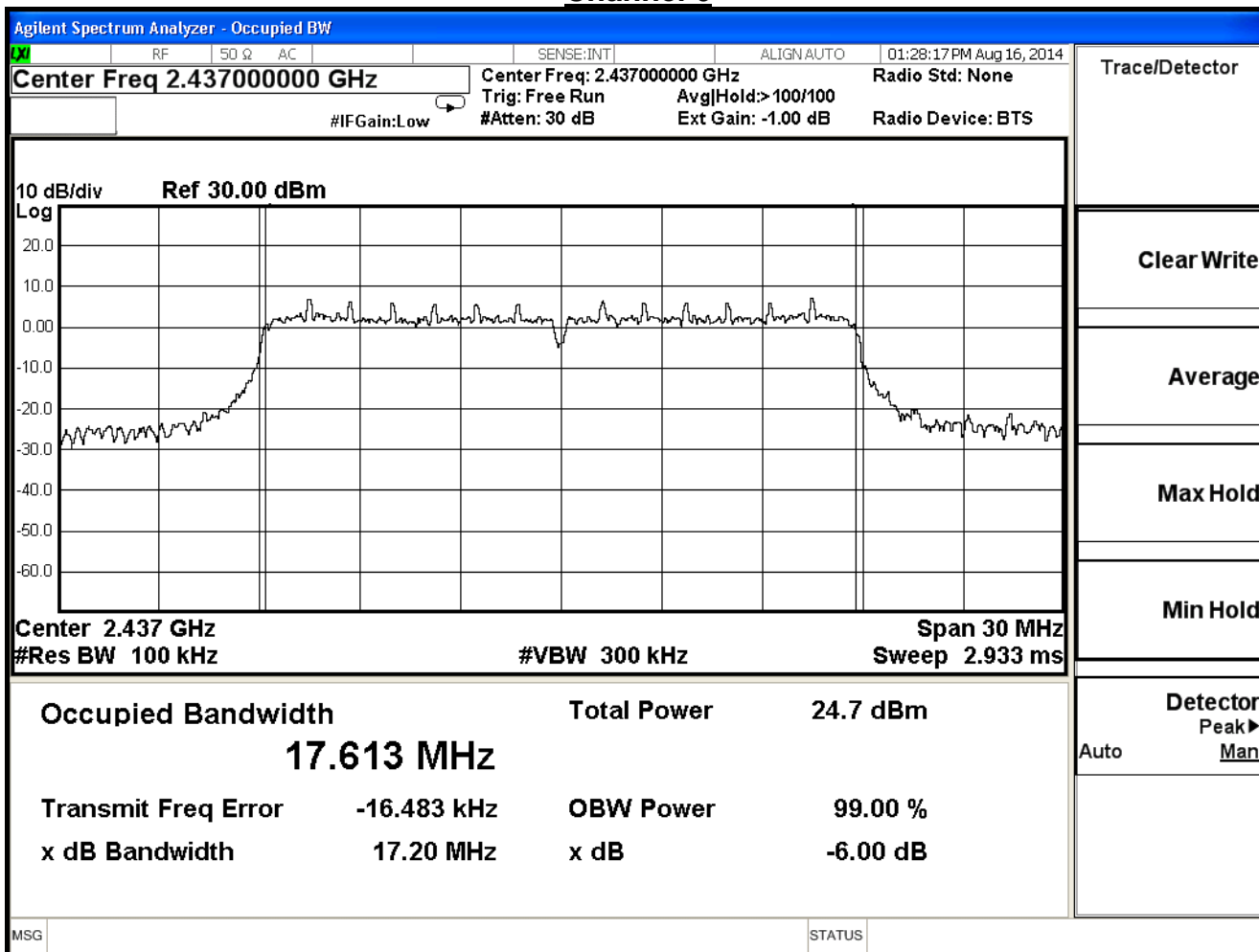

## Channel 11

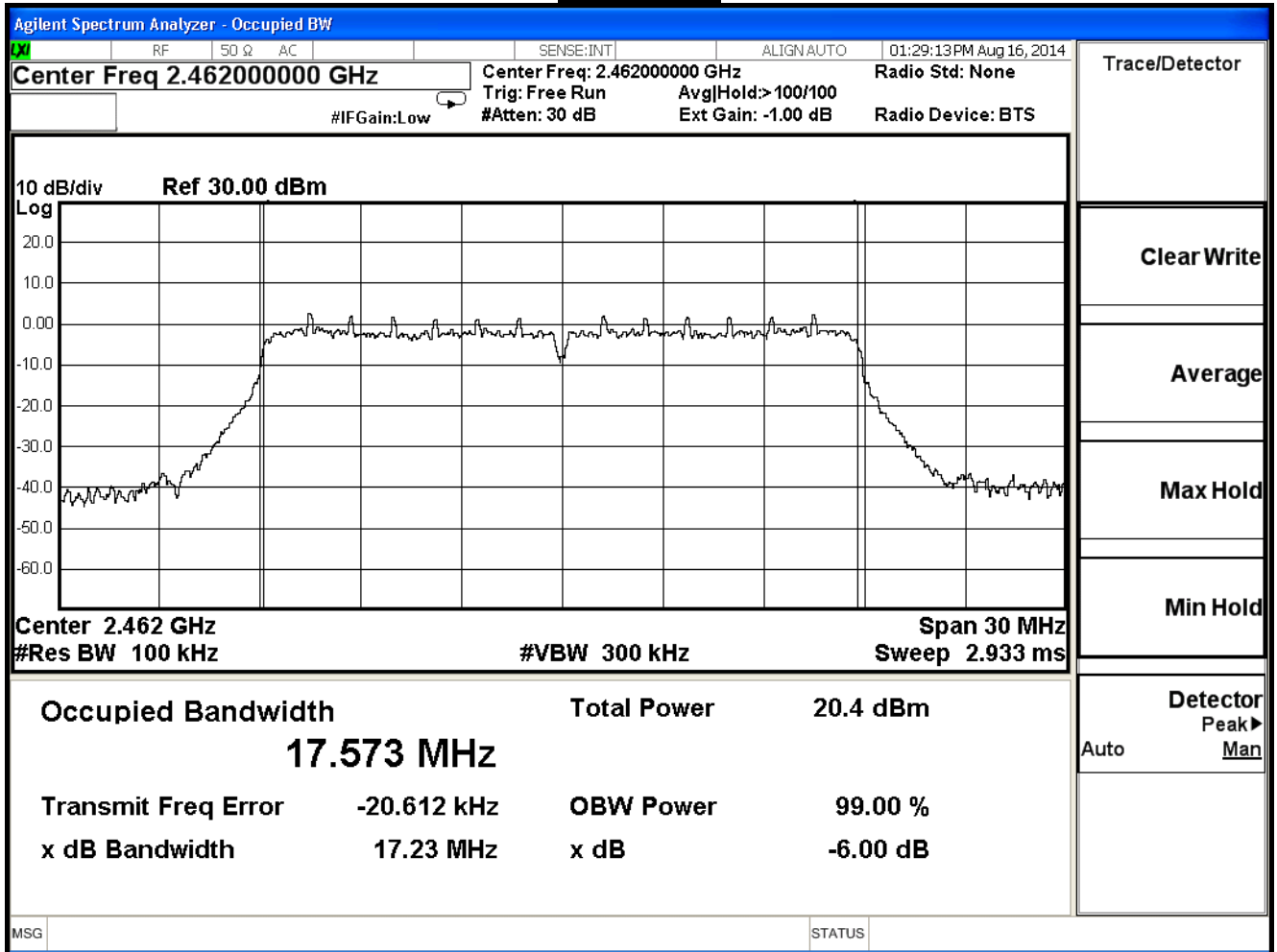

**8. Occupied Bandwidth**

**8.1. Test Equipment**

The following test equipments are used during the test:

Occupied Bandwidth / SR7

Instrument	Manufacturer	Model No.	Serial No	Next Cal. Date
Spectrum Analyzer	Agilent	N9010A-EXA	US47140172	2015/07/14

Note: 1. All equipments that need to calibrate are with calibration period of 1 year.

**8.2. Test Setup**

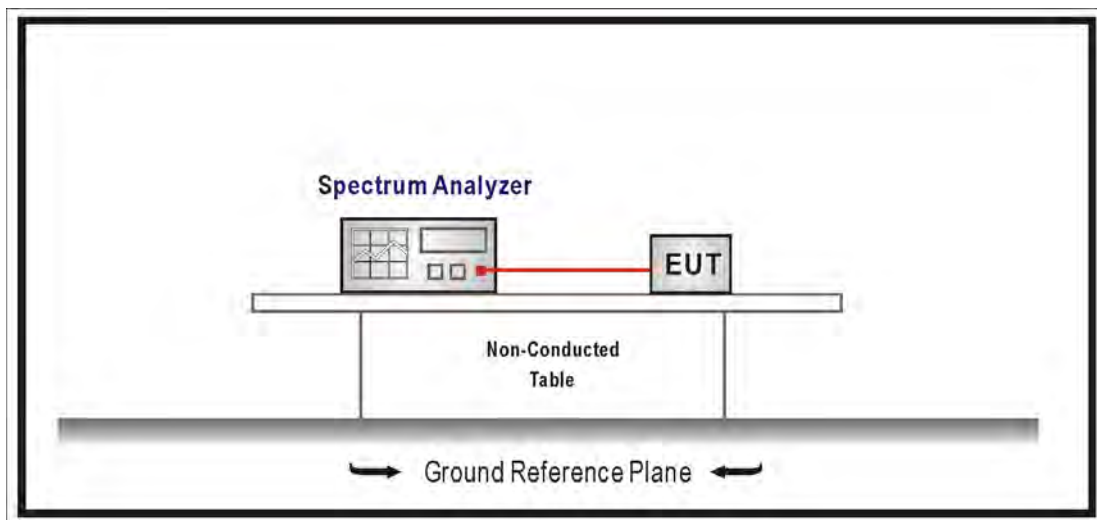

**8.3. Test Procedures**

The EUT was setup according to ANSI C63.4: 2009; tested according to DTS test procedure section 8.1 of KDB558074 v03r02 for compliance to FCC 47CFR 15.247 requirements. Set RBW = 100KHz, VBW  $\geq$  3xRBW, Sweep time=Auto, Set Peak detector.

**8.4. Limits**

N/A

**8.5. Test Specification**

According to FCC Part 15 Subpart C Paragraph 15.247: 2013

**8.6. Uncertainty**

The measurement uncertainty is defined as  $\pm$ 150Hz

## 8.7. Test Result

Product	WiFi HD Baby Cam		
Test Item	Occupied Bandwidth		
Test Mode	Mode 1: Transmit		
Date of Test	2014/08/16	Test Site	SR7

802.11 b, ANT 0

Channel No.	Frequency (MHz)	Measurement Level (MHz)	Required Limit (MHz)	Result
1	2412	12.190	--	Pass
6	2437	12.175	--	Pass
11	2462	12.160	--	Pass

### Channel 1

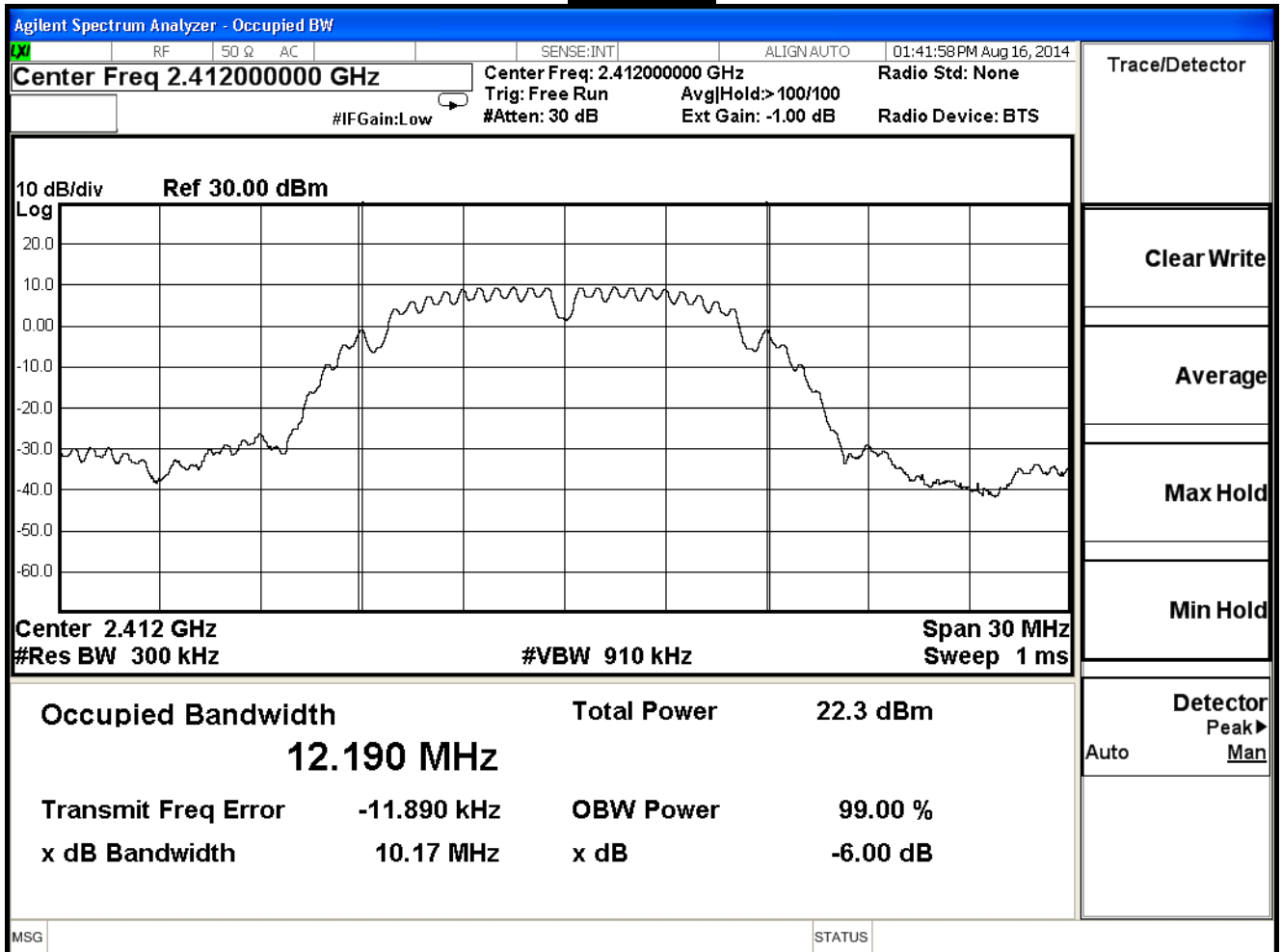

## Channel 6

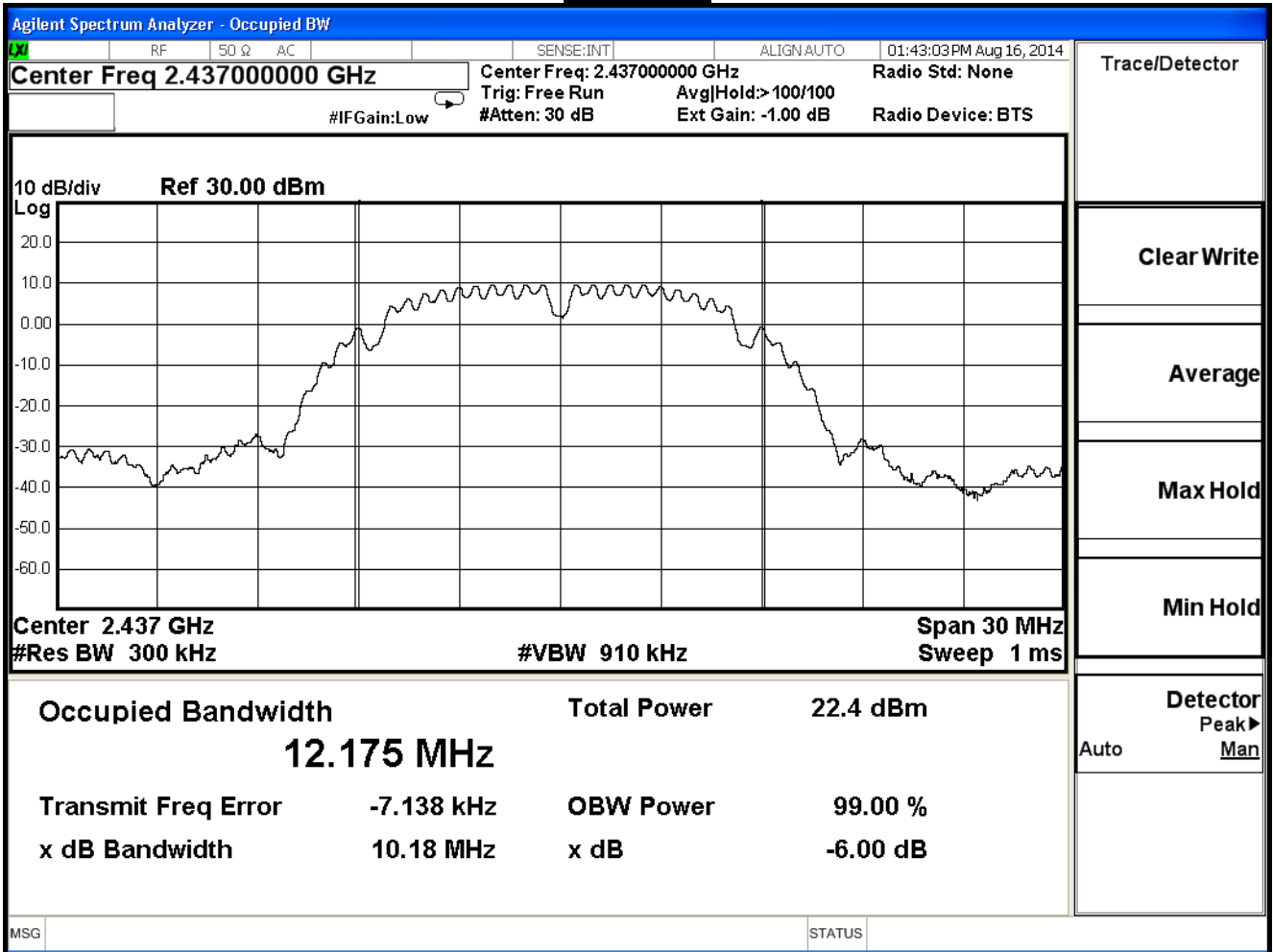

## Channel 11

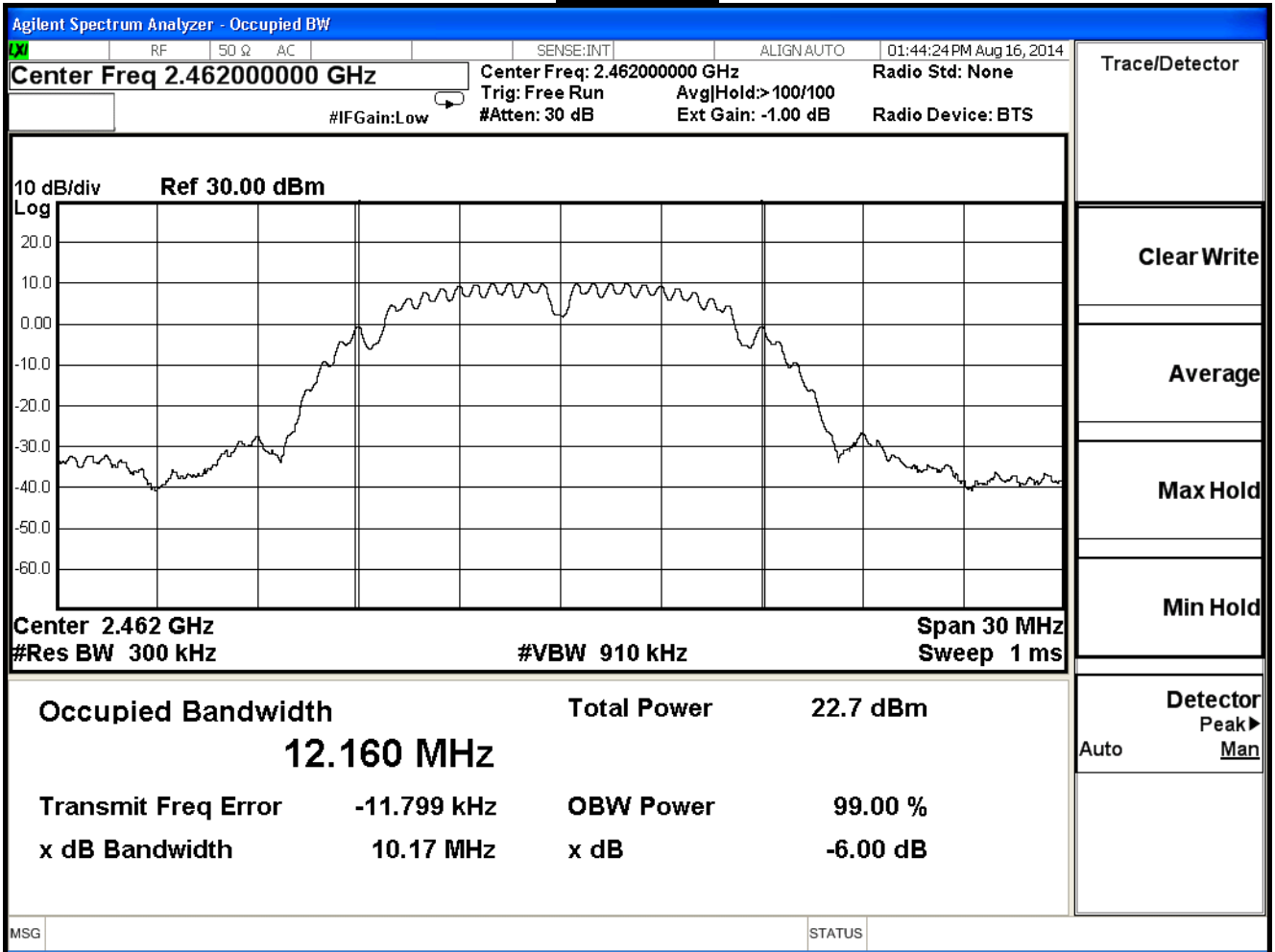

Product	WiFi HD Baby Cam		
Test Item	Occupied Bandwidth		
Test Mode	Mode 1: Transmit		
Date of Test	2014/08/16	Test Site	SR7

IEEE 802.11g, ANT 0				
Channel No.	Frequency (MHz)	Measurement Level (MHz)	Required Limit (MHz)	Result
1	2412	16.892	--	Pass
6	2437	17.028	--	Pass
11	2462	16.884	--	Pass

### Channel 1

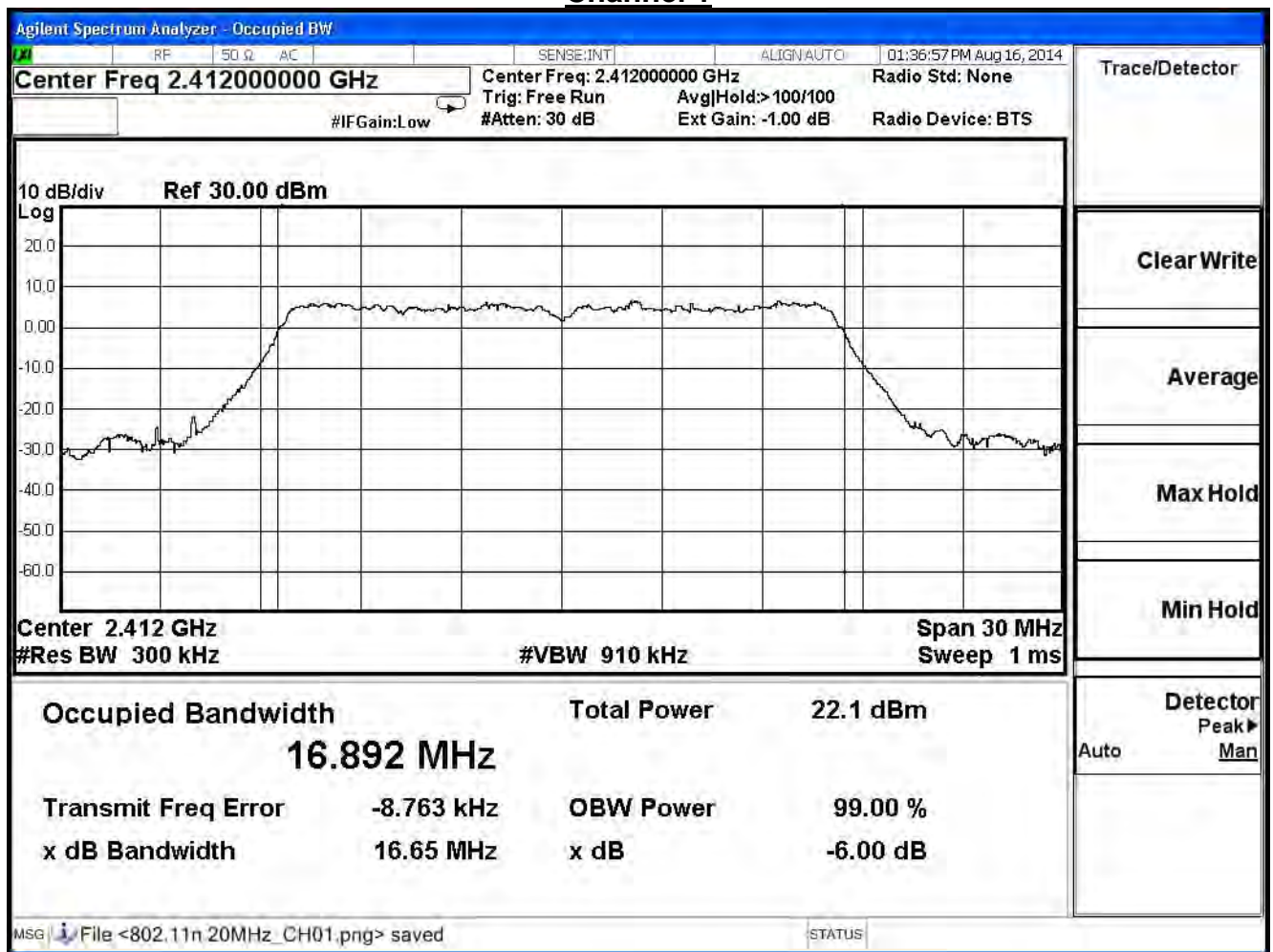

## Channel 6

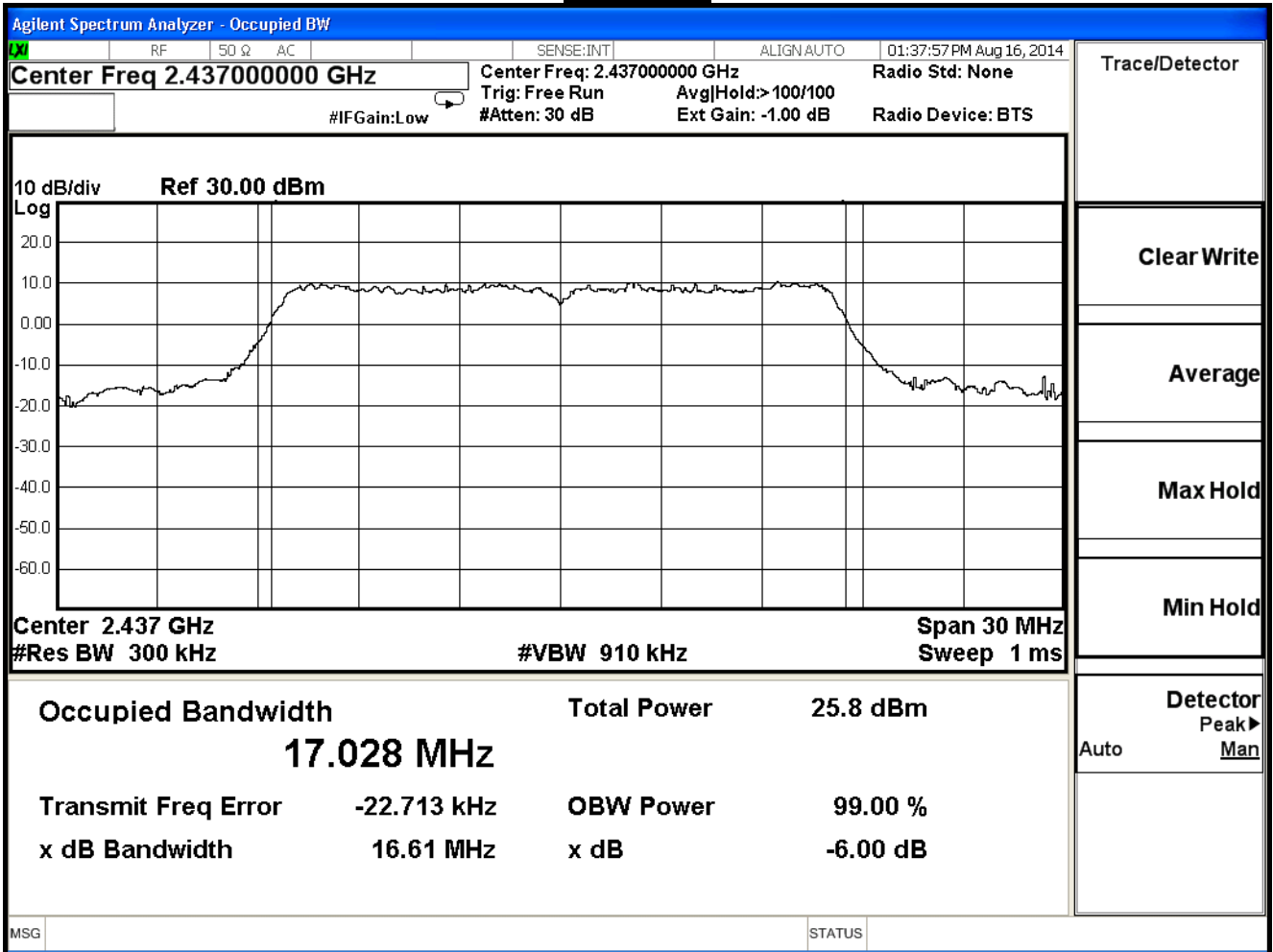



## Channel 11

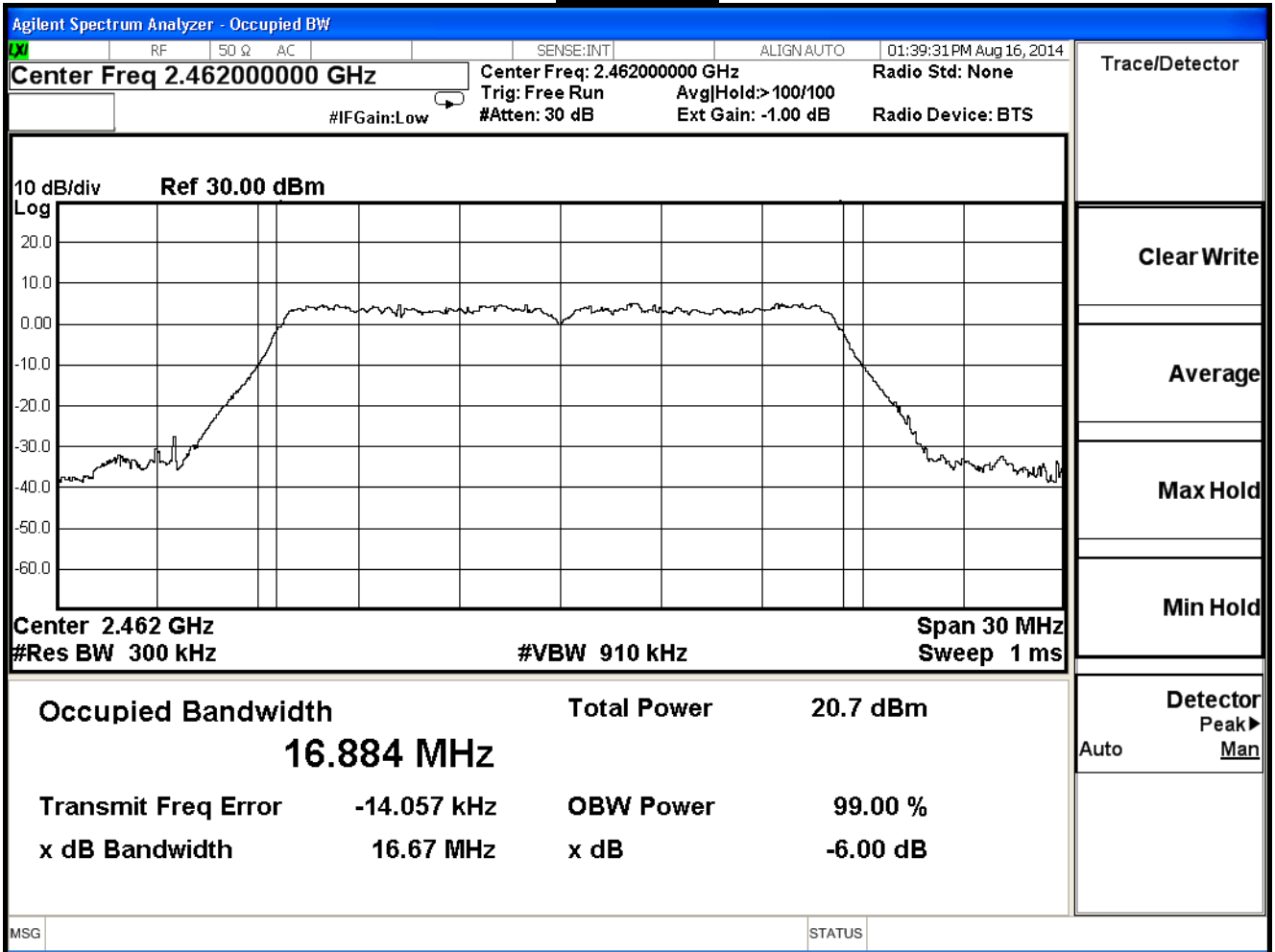

Product	WiFi HD Baby Cam		
Test Item	Occupied Bandwidth		
Test Mode	Mode 1: Transmit		
Date of Test	2014/08/16	Test Site	SR7

IEEE 802.11n (20MHz), ANT 0				
Channel No.	Frequency (MHz)	Measurement Level (MHz)	Required Limit (MHz)	Result
1	2412	17.728	--	Pass
6	2437	17.826	--	Pass
11	2462	17.711	--	Pass

### Channel 1

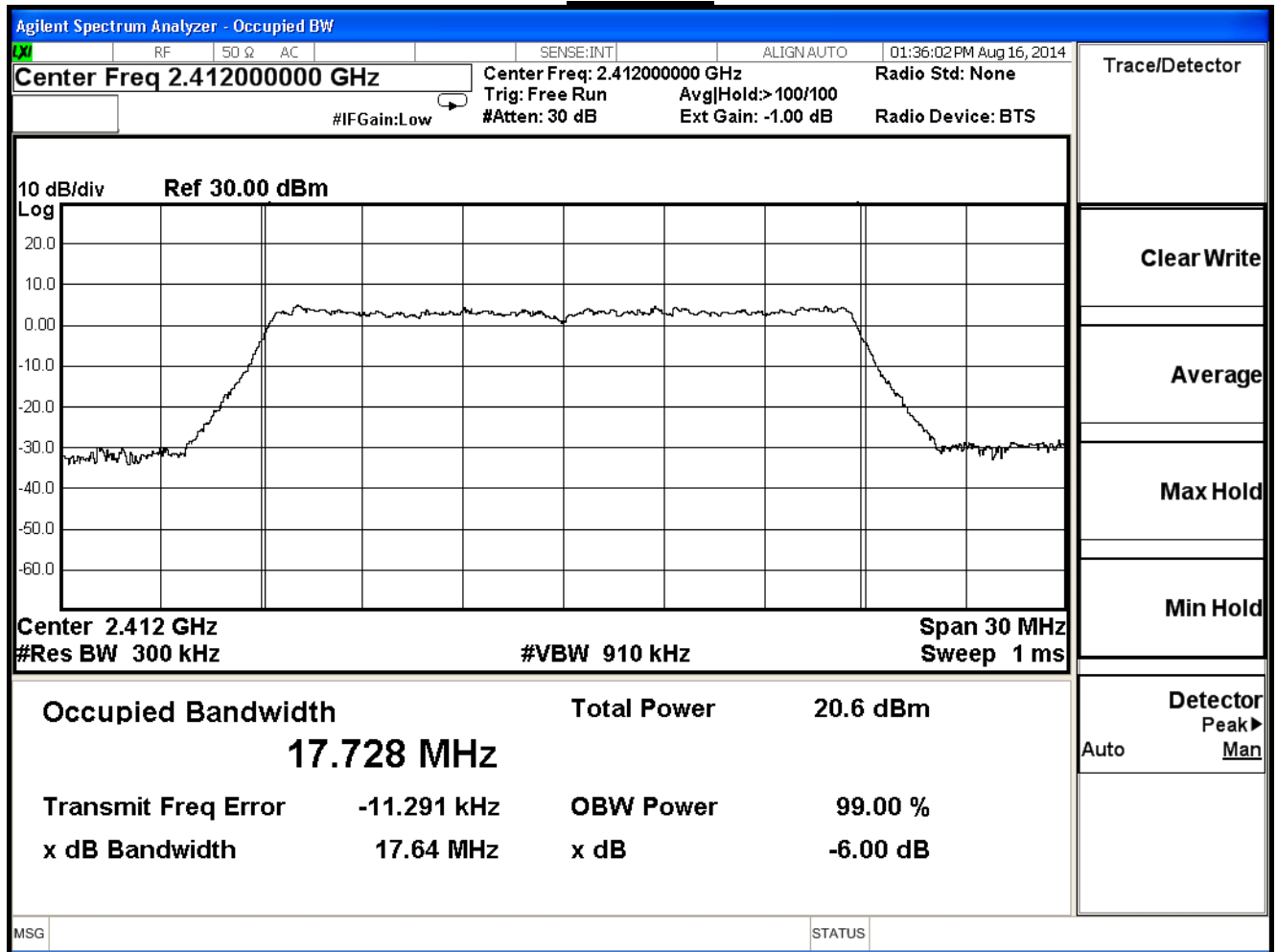

Channel 6

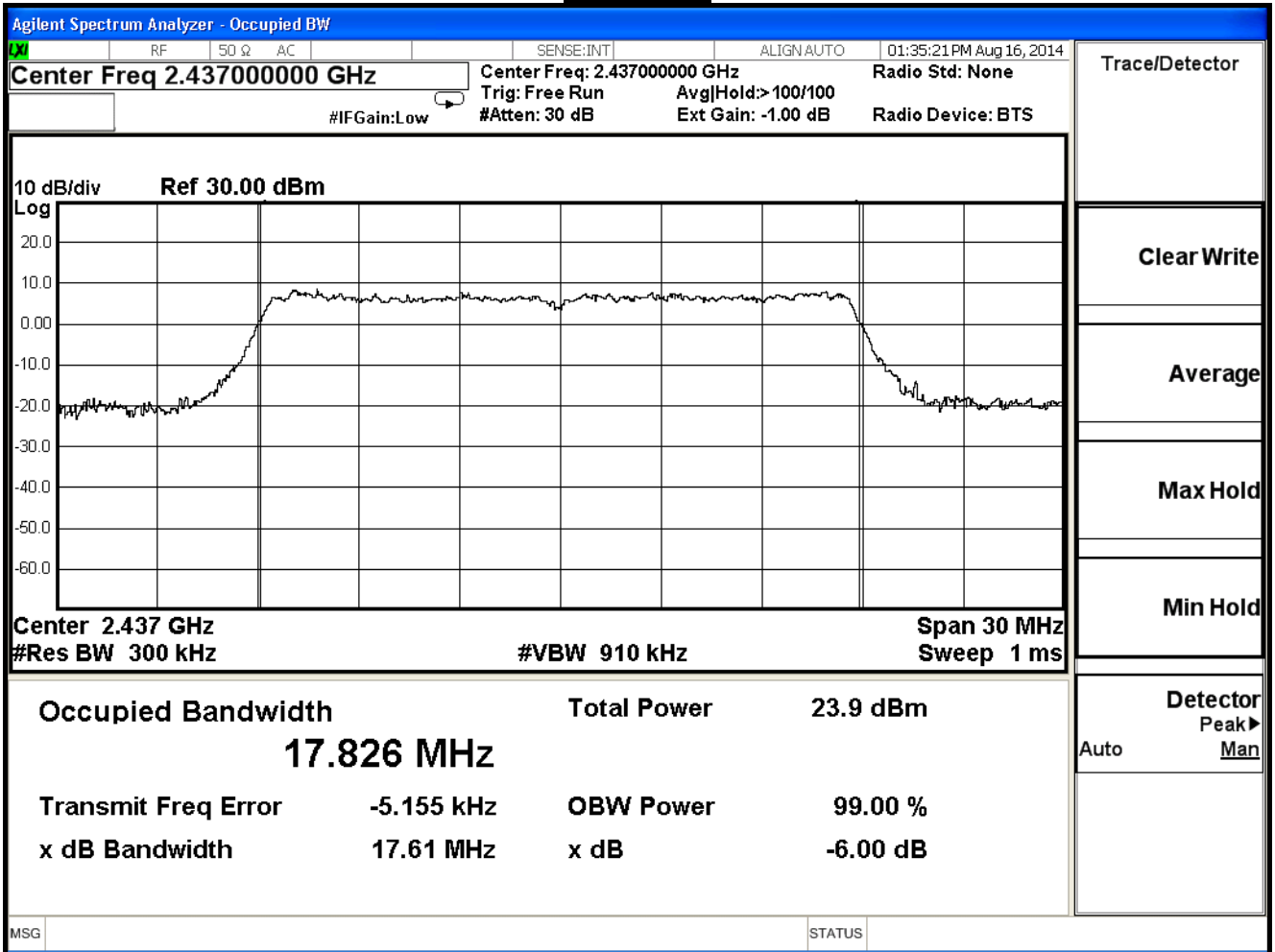

## Channel 11

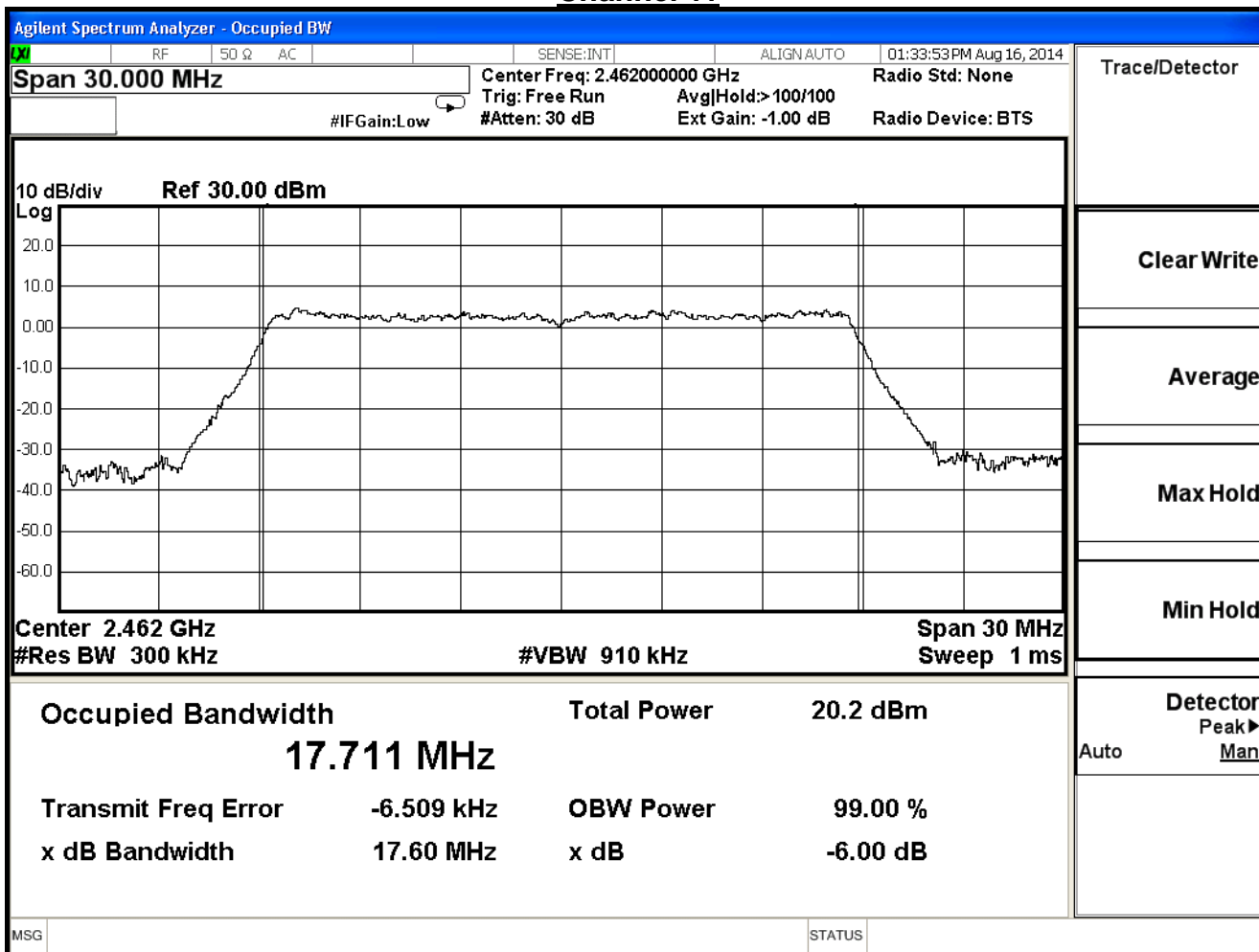

**9. Power Density**

**9.1. Test Equipment**

The following test equipment is used during the test:

**Power Density / SR7**

Instrument	Manufacturer	Model No.	Serial No	Next Cal. Date
Spectrum Analyzer	Agilent	N9010A-EXA	US47140172	2015/07/14

Note: 1. All equipments that need to calibrate are with calibration period of 1 year.

**9.2. Test Setup**

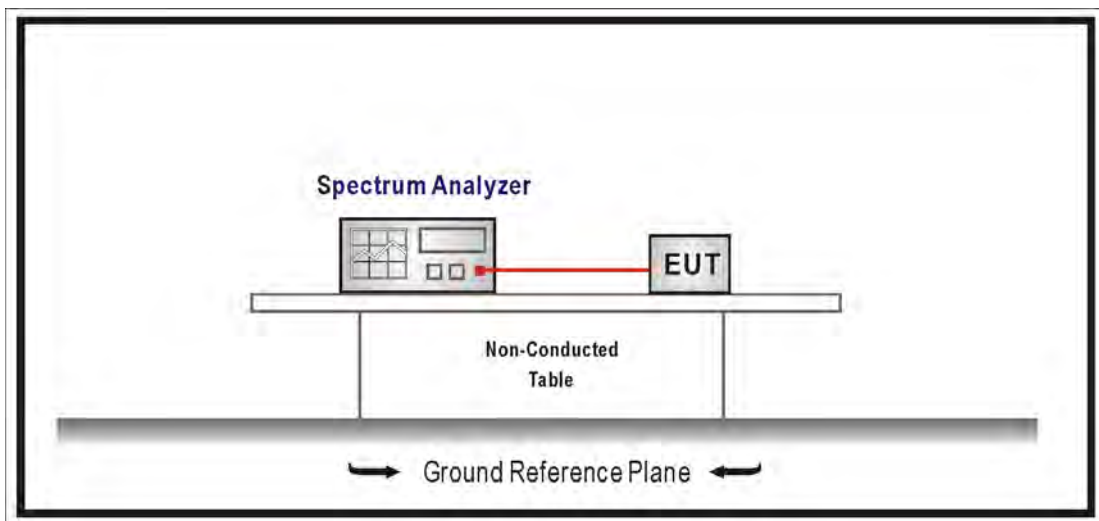

**9.3. Limits**

The peak power spectral density conducted from the intentional radiated to the antenna shall not be greater than +8dBm in any 3kHz band during any time interval of continuous transmission.

**9.4. Test Procedures**

The EUT was setup according to ANSI C63.4: 2009; tested according to DTS test procedure section 10.2 of KDB558074 v03r02 for compliance to FCC 47CFR 15.247 requirements. Set 3KHz  $\leq$  RBW  $\leq$  100 kHz, Set VBW  $\geq$  3xRBW, Sweep time=Auto, Set Peak detector; The tested according to section E)c) of KDB662911 v02v01.

**9.5. Test Specification**

According to FCC Part 15 Subpart C Paragraph 15.247: 2013

**9.6. Uncertainty**

The measurement uncertainty is defined as  $\pm 1.27\text{dB}$ .

## 9.7. Test Result

Product	WiFi HD Baby Cam		
Test Item	Power Density		
Test Mode	Mode 1: Transmit		
Date of Test	2014/08/16	Test Site	SR7

IEEE 802.11b, ANT 0				
Channel No.	Frequency (MHz)	Measure Level (dBm)	Limit (dBm)	Result
1	2412	-9.024	≤ 8	Pass
6	2437	-9.079	≤ 8	Pass
11	2462	-9.694	≤ 8	Pass

### Channel 1

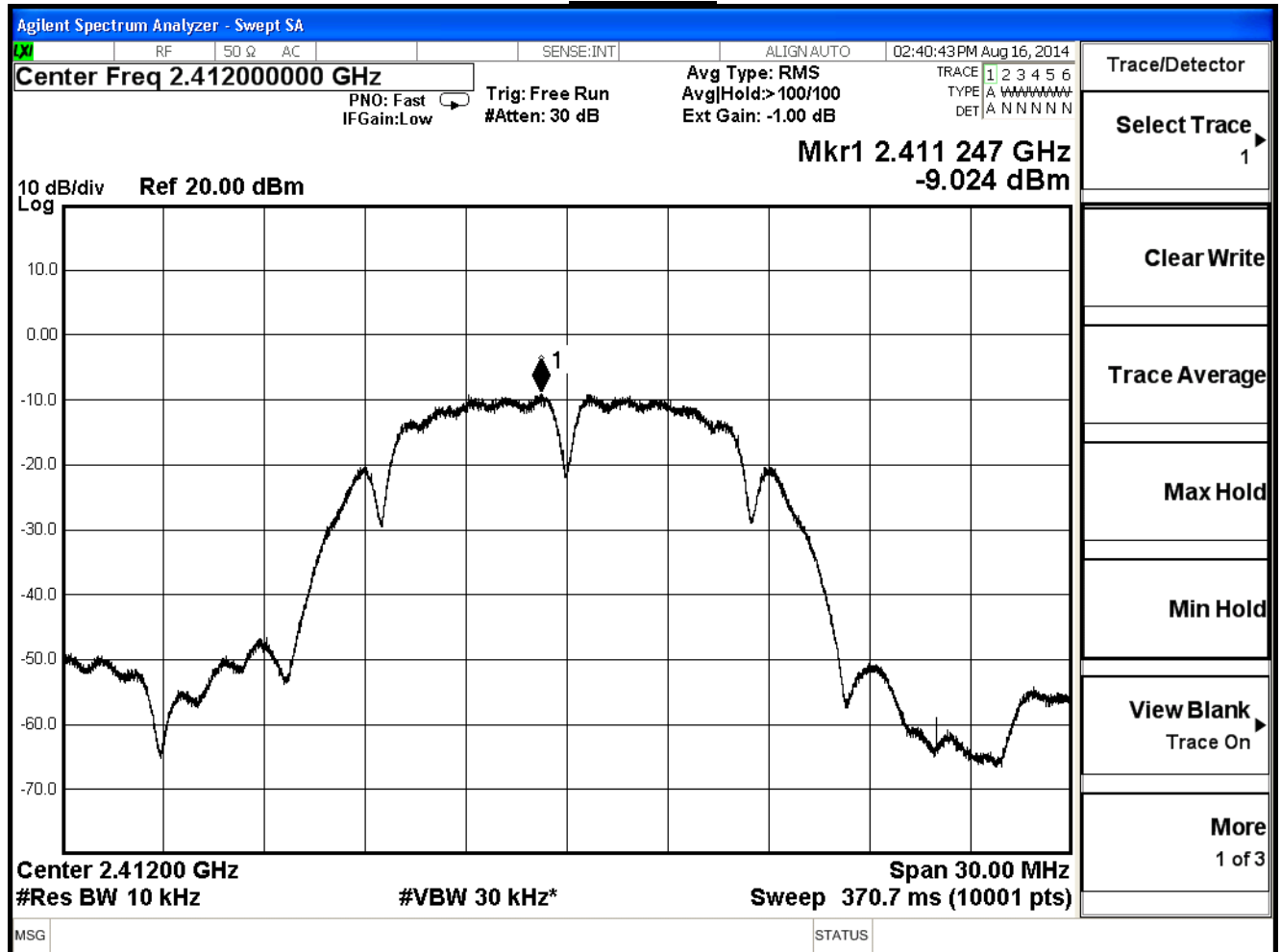

Channel 6

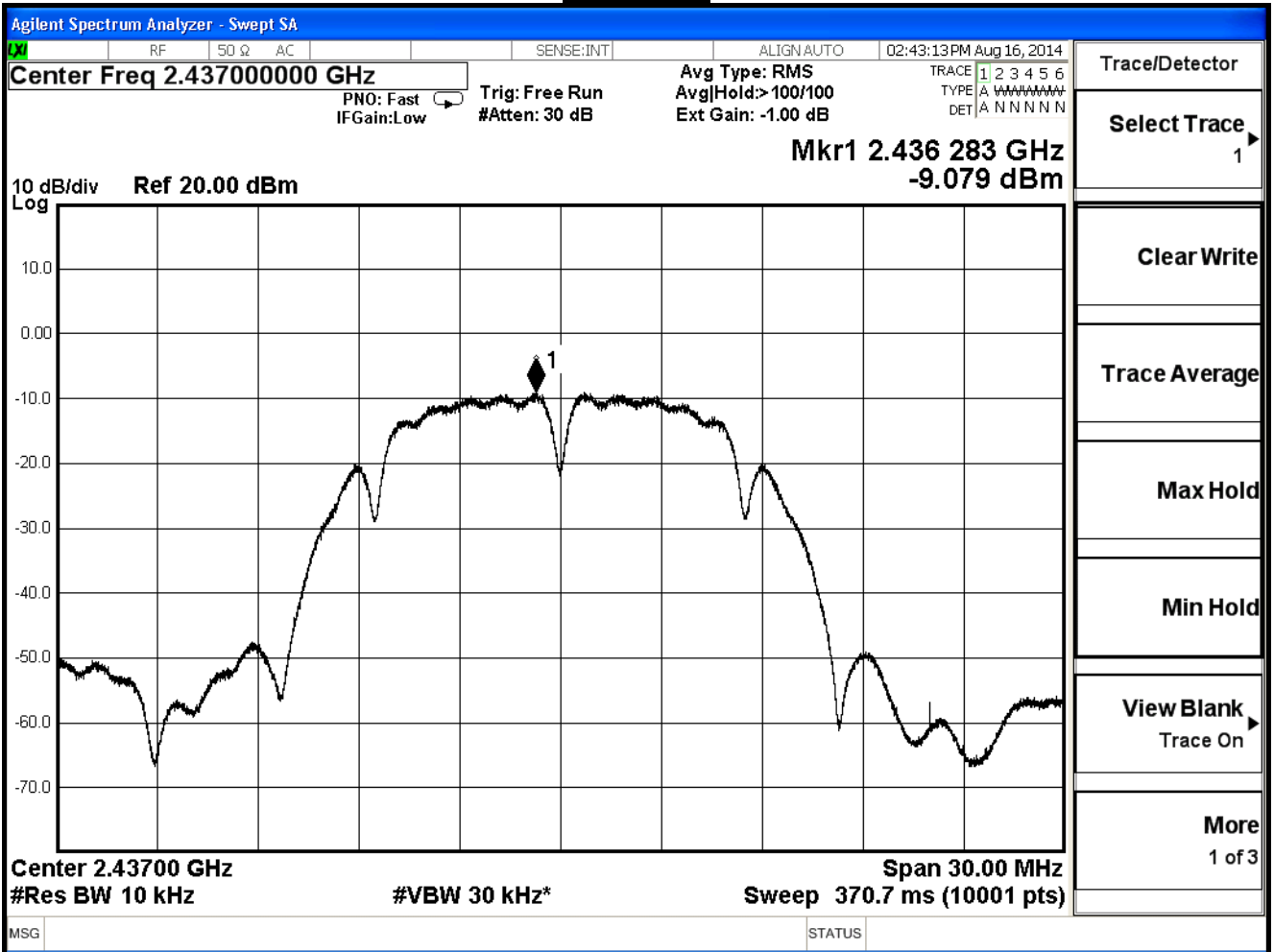



Channel 11

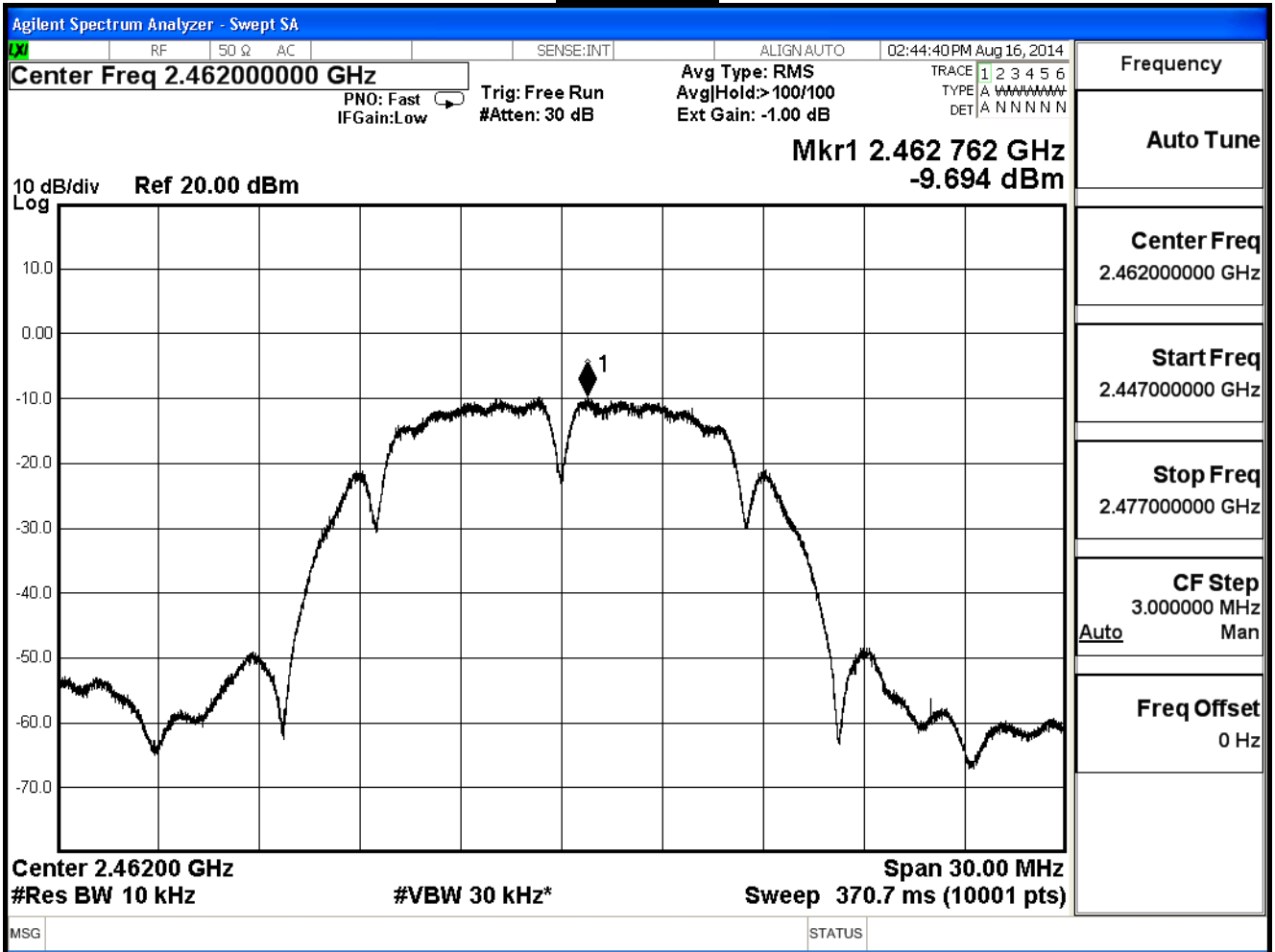

Product	WiFi HD Baby Cam		
Test Item	Power Density		
Test Mode	Mode 1: Transmit		
Date of Test	2014/08/16	Test Site	SR7

IEEE 802.11g, ANT 0				
Channel No.	Frequency (MHz)	Measurement (dBm)	Limit (dBm)	Result
1	2412	-13.934	≤ 8	Pass
6	2437	-9.371	≤ 8	Pass
11	2462	-15.765	≤ 8	Pass

### Channel 1

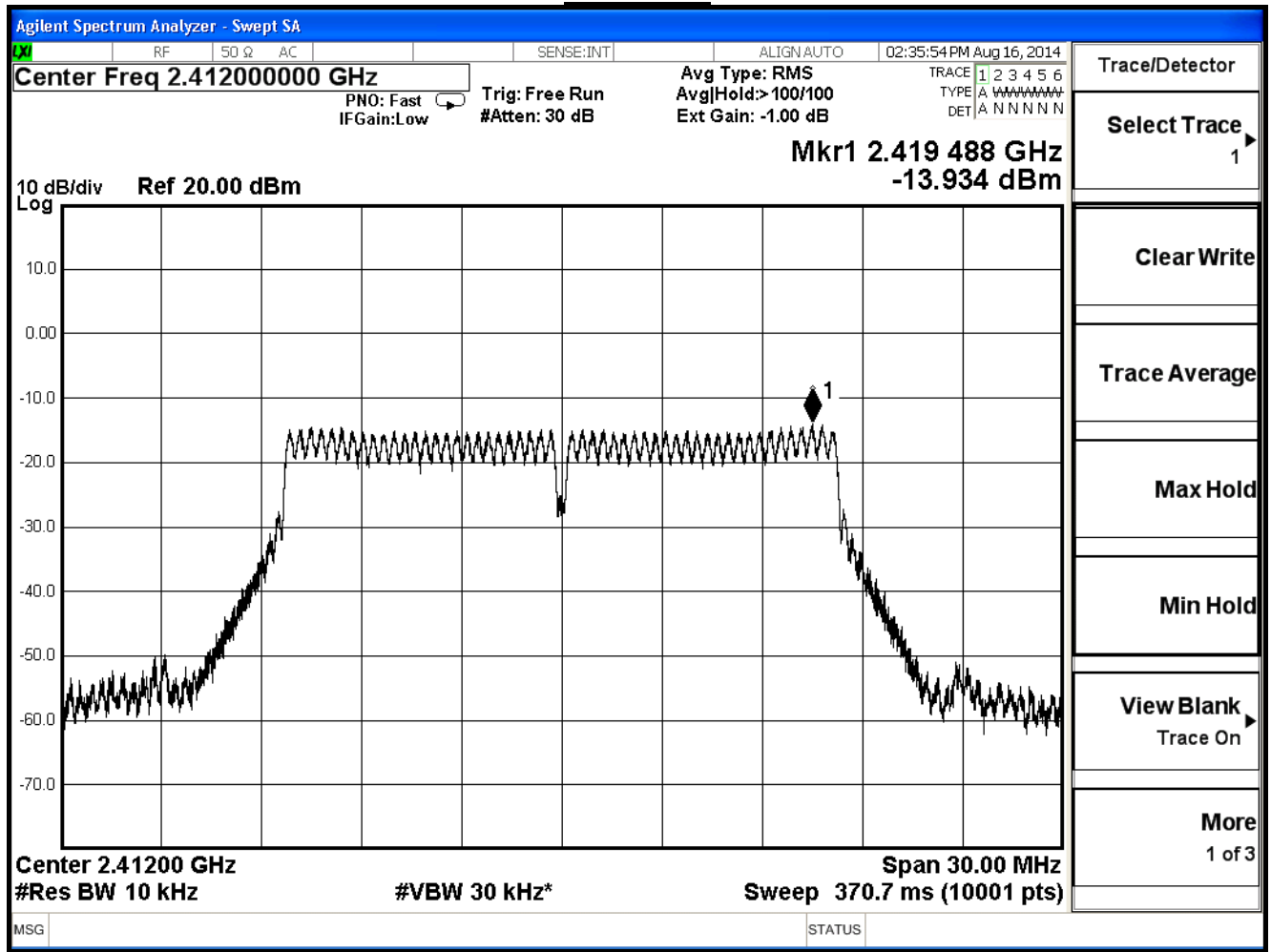

Channel 6

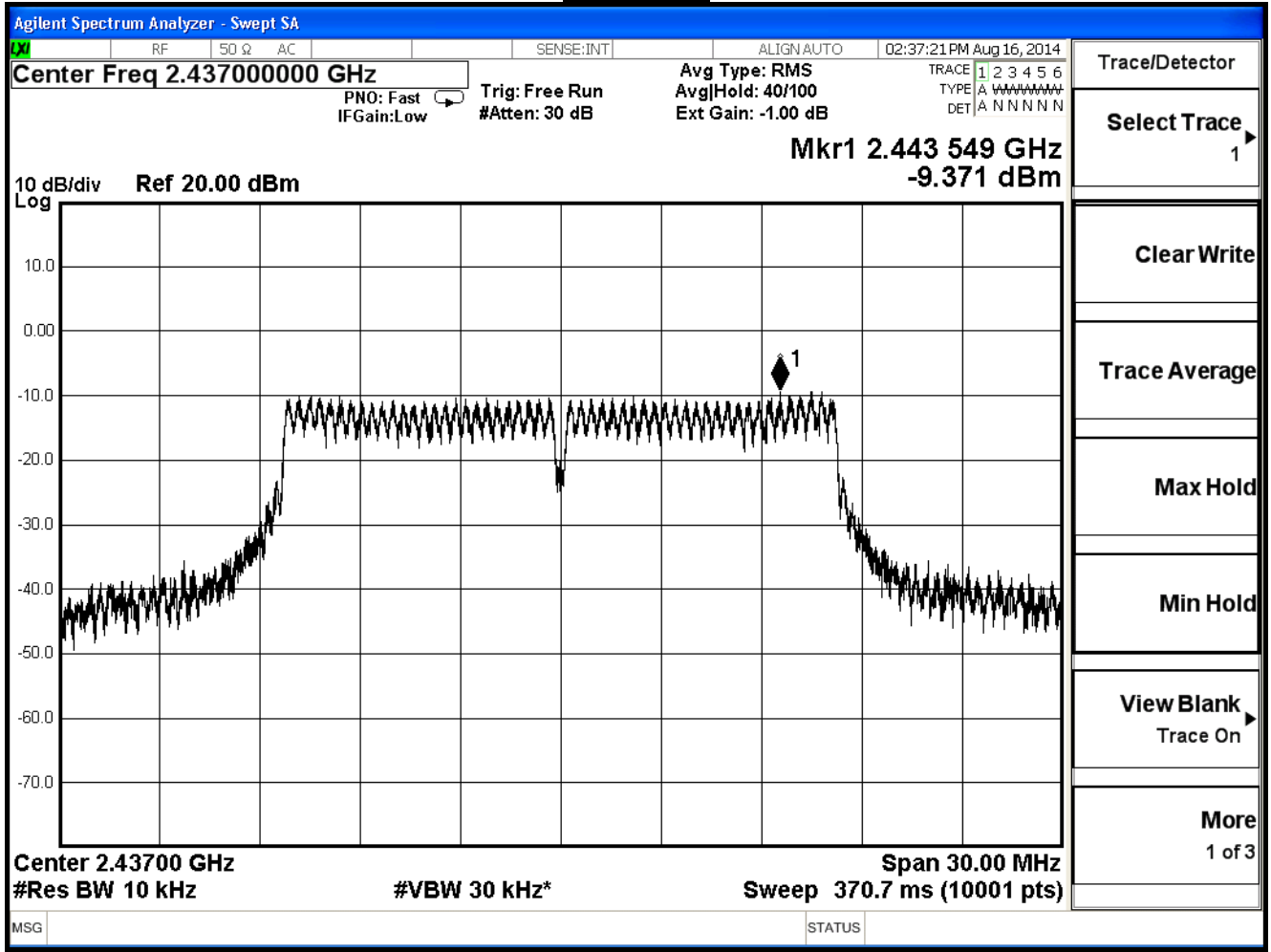

## Channel 11

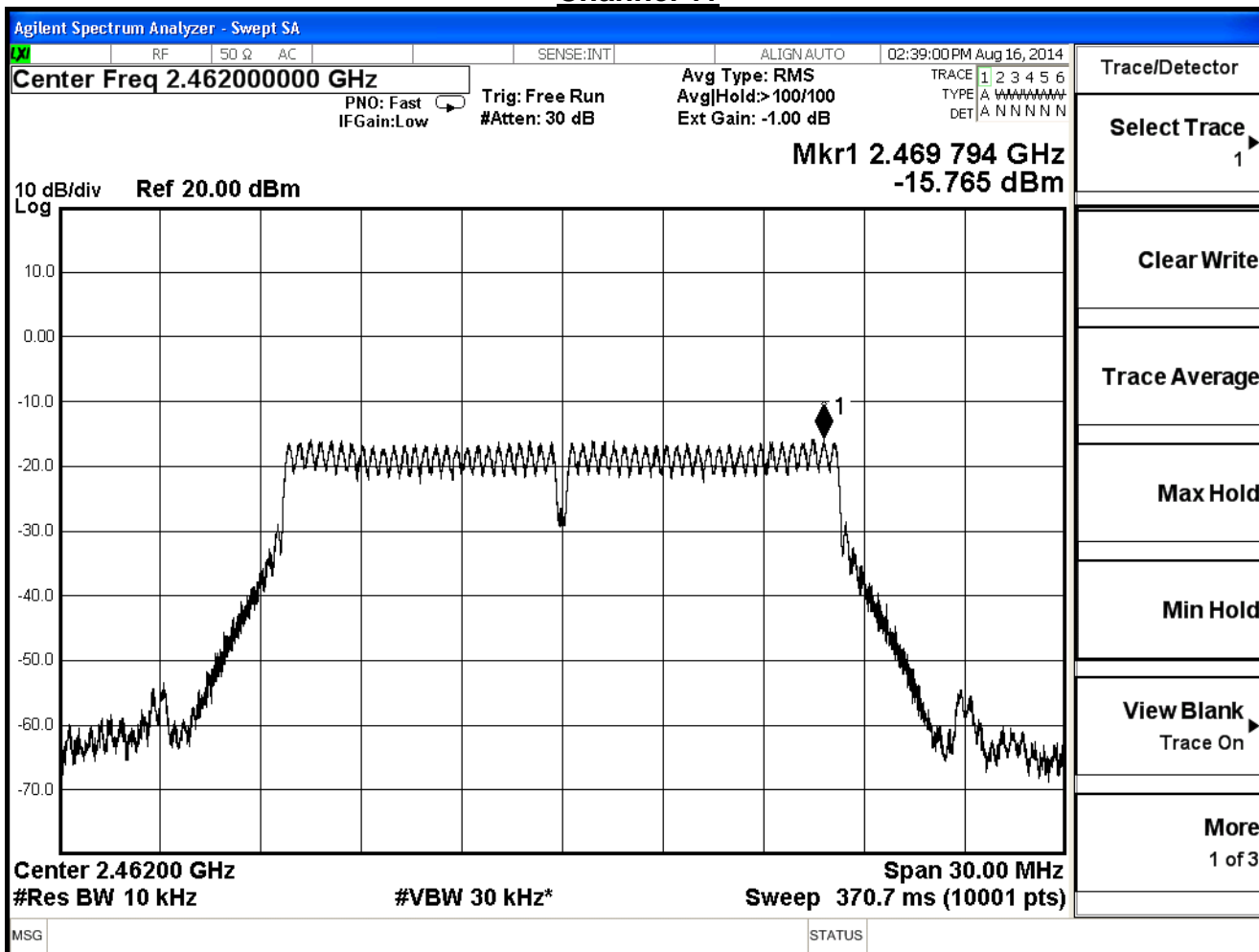

Product	WiFi HD Baby Cam		
Test Item	Power Density		
Test Mode	Mode 1: Transmit		
Date of Test	2014/08/16	Test Site	SR7

IEEE802.11n_20MHz, ANT 0				
Channel No.	Frequency (MHz)	Measure Level (dBm)	Limit (dBm)	Result
1	2412	-16.136	≤ 8	Pass
6	2437	-12.020	≤ 8	Pass
11	2462	-16.037	≤ 8	Pass

### Channel 1

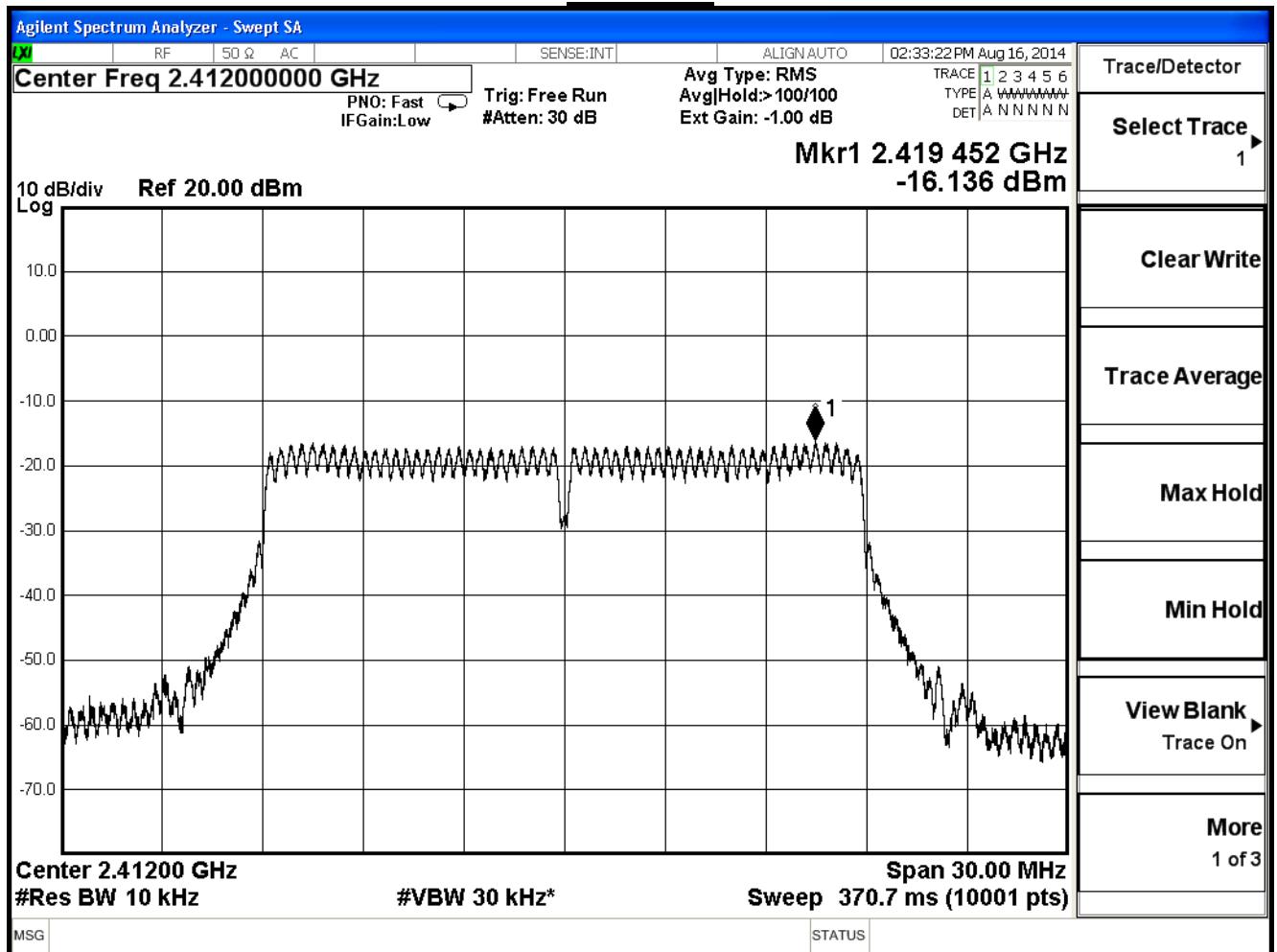

Channel 6

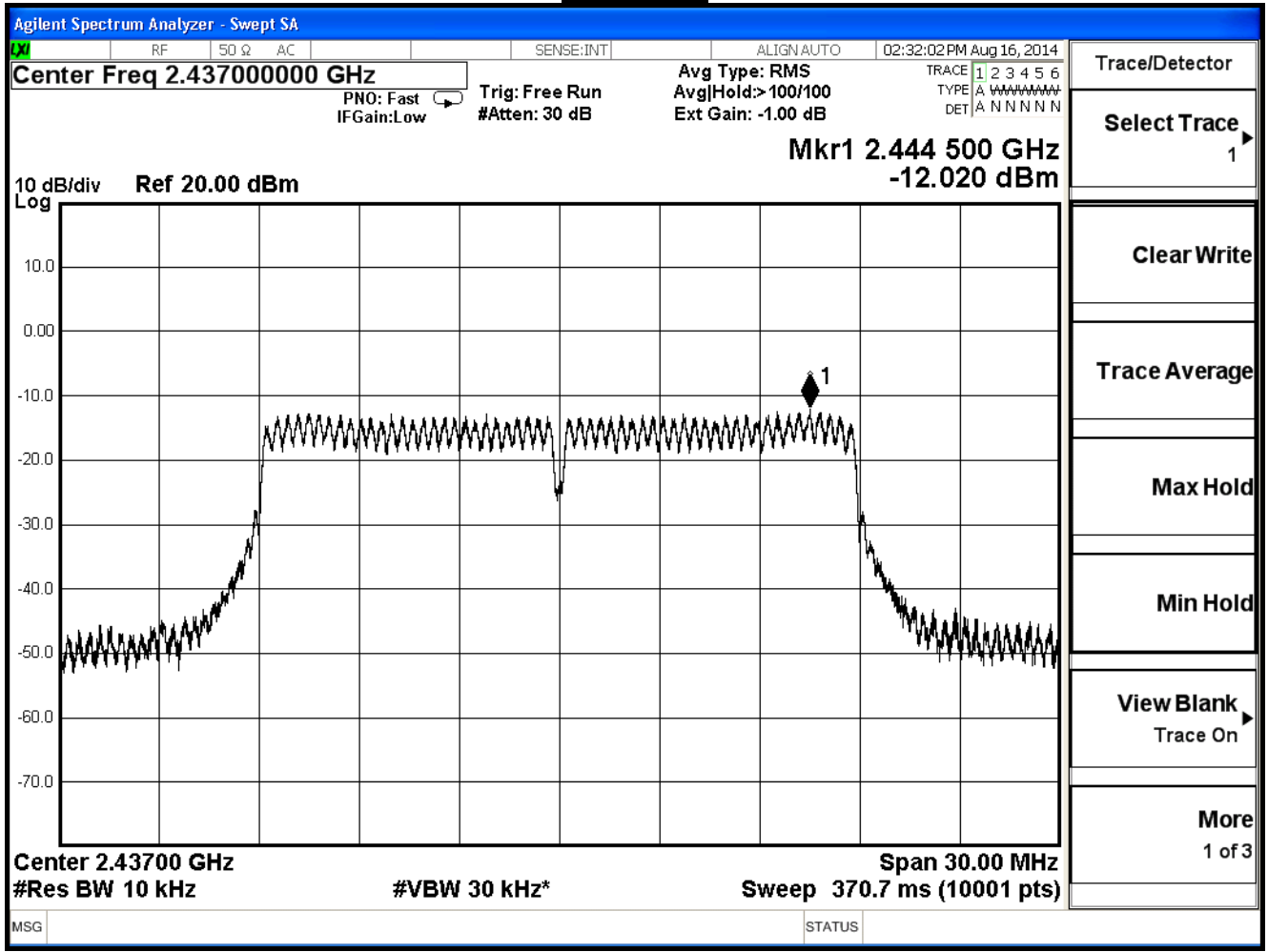

### Channel 11

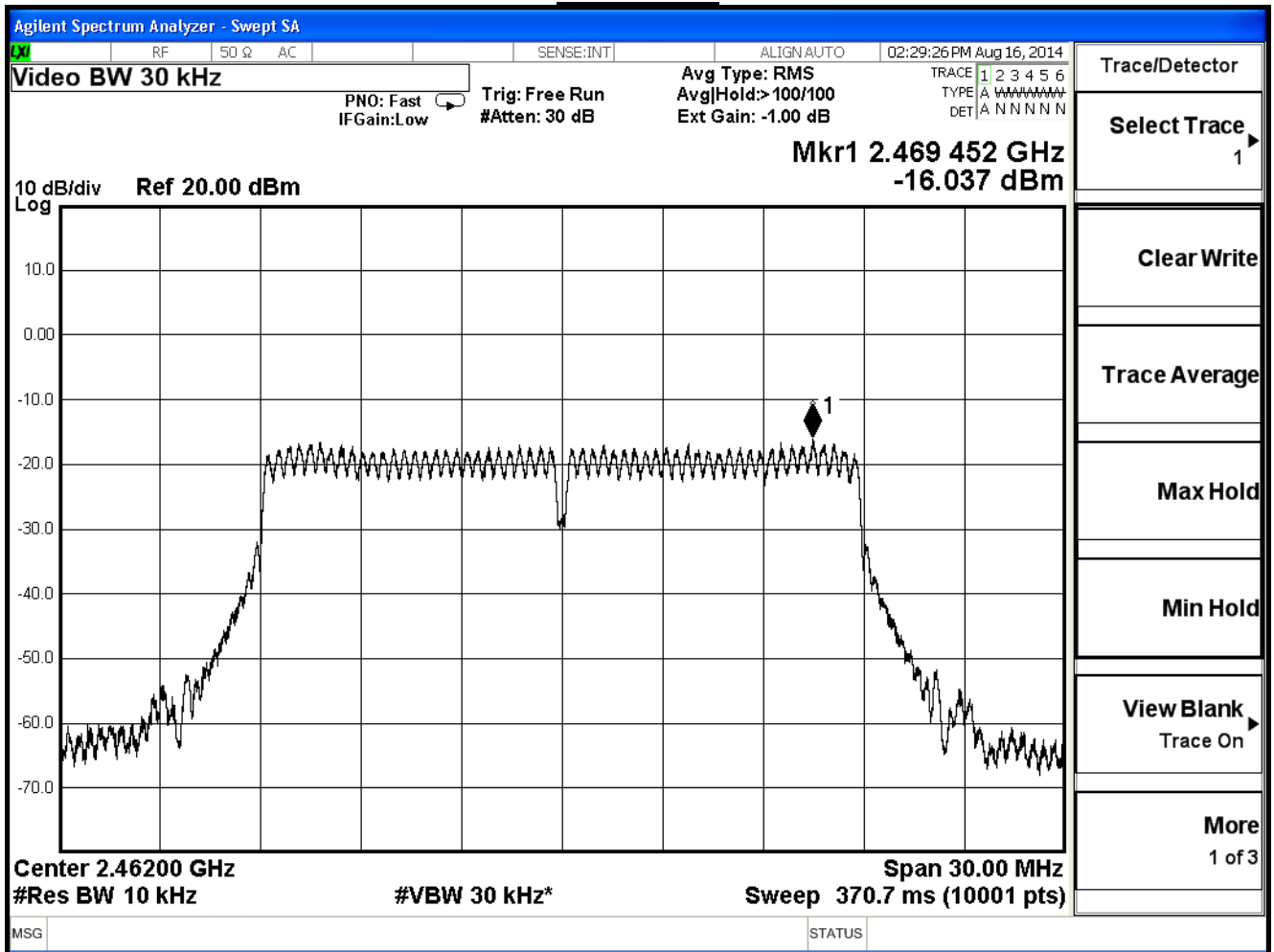

Trace/Detector

Select Trace 1

Clear Write

Trace Average

Max Hold

Min Hold

View Blank Trace On

More 1 of 3