



**FCC 47 CFR PART 15 SUBPART C AND ANSI C63.10:2009  
TEST REPORT (Class II Permissive Change Report)**

**For**

**WiFi Baby Cam**

**Model : TV-IP743SIC**

**Trade Name : TRENDnet**

**Issued for**

**TRENDnet, INC.**

**20675 Manhattan Place, Torrance, CA 90501 USA**

**Issued by**

**Compliance Certification Services Inc.  
Hsinchu Lab.**

**NO. 989-1 Wen Shan Rd., Shang Shan Village,  
Qionglin Shiang Hsinchu County 30741, Taiwan, R.O.C**

**TEL: +886-3-5921698**

**FAX: +886-3-5921108**

**<http://www.ccsrf.com>**

**E-Mail : [service@ccsrf.com](mailto:service@ccsrf.com)**

**Issued Date: June 30, 2014**



**Note:** *This report shall not be reproduced except in full, without the written approval of Compliance Certification Services Inc. This document may be altered or revised by Compliance Certification Services Inc. personnel only, and shall be noted in the revision section of the document. The client should not use it to claim product endorsement by TAF or any government agencies. The test results of this report relate only to the tested sample identified in this report.*



## Revision History

Rev.	Issue Date	Revisions	Effect Page	Revised By
00	06/30/2014	Initial Issue	All Page 84	Michelle Chiu



**TABLE OF CONTENTS**

<b>TITLE</b>	<b>PAGE NO.</b>
<b>1. TEST REPORT CERTIFICATION .....</b>	<b>4</b>
<b>2. EUT DESCRIPTION .....</b>	<b>5</b>
2.1 DESCRIPTION OF EUT & POWER.....	5
2.2 DESCRIPTION OF CLASS II CHANGE .....	6
<b>3. DESCRIPTION OF TEST MODES .....</b>	<b>7</b>
<b>4. TEST METHODOLOGY .....</b>	<b>8</b>
<b>5. FACILITIES AND ACCREDITATION .....</b>	<b>8</b>
5.1 FACILITIES .....	8
5.2 ACCREDITATIONS.....	8
5.3 MEASUREMENT UNCERTAINTY .....	9
<b>6. SETUP OF EQUIPMENT UNDER TEST.....</b>	<b>10-11</b>
<b>7. FCC PART 15.247 REQUIREMENTS .....</b>	<b>12</b>
7.1 6dB BANDWIDTH .....	12-20
7.2 MAXIMUM PEAK OUTPUT POWER .....	21-23
7.3 AVERAGE POWER .....	24-26
7.4 POWER SPECTRAL DENSITY .....	27-35
7.5 CONDUCTED SPURIOUS EMISSION .....	36-46
7.6 RADIATED EMISSION.....	47-74
7.7 CONDUCTED EMISSION.....	75-80
<b>APPENDIX EXTERNAL PHOTOS .....</b>	<b>81-84</b>



# 1. TEST REPORT CERTIFICATION

**Applicant** : TRENDnet, INC.  
**Address** : 20675 Manhattan Place, Torrance, CA 90501 USA  
**Equipment Under Test** : WiFi Baby Cam  
**Model** : TV-IP743SIC  
**Trade Name** : TRENDnet  
**Tested Date** : April 23 ~ June 17, 2014

APPLICABLE STANDARD	
Standard	Test Result
FCC Part 15 Subpart C AND ANSI C63.10:2009	PASS

WE HEREBY CERTIFY THAT: The above equipment has been tested by Compliance Certification Services Inc., and found compliance with the requirements set forth in the technical standards mentioned above. The results of testing in this report apply only to the product/system, which was tested. Other similar equipment will not necessarily produce the same results due to production tolerance and measurement uncertainties.

**Approved by:**

Sb. Lu  
Sr. Engineer

**Reviewed by:**

Gundam Lin  
Sr. Engineer



## 2. EUT DESCRIPTION

### 2.1 DESCRIPTION OF EUT & POWER

<b>Product Name</b>	WiFi Baby Cam
<b>Model Number</b>	TV-IP743SIC
<b>Identify Number</b>	T140423S02
<b>Received Date</b>	April 23, 2014
<b>Frequency Range</b>	IEEE 802.11b/g, 802.11n HT20 : 2412MHz ~ 2462MHz
<b>Transmit Power</b>	IEEE 802.11b : 22.57 dBm (0.1809W) IEEE 802.11g : 23.87 dBm (0.2439W) IEEE 802.11n HT20 : 22.88 dBm (0.1940W)
<b>Channel Spacing</b>	IEEE 802.11b/g, 802.11n HT20 : 5MHz
<b>Channel Number</b>	IEEE 802.11b/g, 802.11n HT20 : 11 Channels
<b>Transmit Data Rate</b>	IEEE 802.11b : 11, 5.5, 2, 1 Mbps IEEE 802.11g : 54, 48, 36, 24, 18, 12, 9, 6 Mbps IEEE 802.11nHT20 : 72.2, 65, 58.5, 57.8, 52, 43.3, 39, 28.9, 26, 21.7, 19.5, 14.4, 13, 7.2, 6.5Mbps
<b>Type of Modulation</b>	IEEE 802.11b : DSSS (CCK, DQPSK, DBPSK) IEEE 802.11g : OFDM (64QAM, 16QAM, QPSK, BPSK) IEEE 802.11n HT20 : OFDM (64QAM, 16QAM, QPSK, BPSK)
<b>Antenna Type</b>	PCB Antenna, Antenna Gain 3.55 dBi
<b>Power Rating</b>	5.0 Vdc
<b>Test Voltage</b>	120Vac, 60Hz
<b>DC Power Cable Type</b>	Non-shielded cable 1.5 m (Non-detachable)
<b>I/O Port</b>	Mini USB Port × 1

#### Power Adapter :

No.	Manufacturer	Model No.	Power Input	Power Output
1	AMIGO	AMS47-0501000FU	100-240Vac, 50/60Hz, 0.2A	5Vdc, 1A

#### Remark :

1. The sample selected for test was engineering sample that approximated to production product and was provided by manufacturer.
2. For more details, please refer to the User's manual of the EUT.
3. This submittal(s) (test report) is intended for FCC ID: XU8TVIP742743 filing to comply with Section 15.207, 15.209 and 15.247 of the FCC Part 15, Subpart C Rules.



## **2.2 DESCRIPTION OF CLASS II CHANGE**

The major change filed under this application is :

1. Change enclosure (Round change to square)
2. Change antenna (Original Antenna Gain : 1.93 dBi change to 3.55dBi and under the same RF output power )
3. Change product description (Wireless Cloud Baby Monitor change to WiFi Baby Cam)

The testing data please refer to section 7.



### 3. DESCRIPTION OF TEST MODES

The EUT (WiFi Baby Cam) had been tested under operating condition.  
IEEE 802.11 b/g, 802.11n HT20 mode : 1TX1RX.

#### Conducted Emission / Radiated Emission Test (Below 1 GHz)

1. The following test modes were scanned during the preliminary test:

No.	Pre-Test Mode
1	Normal Operating (Full Function)

2. After the preliminary scan, the following test mode was found to produce the highest emission level.

Final Test Mode		
Emission	Radiated Emission	Normal Operating (Full Function)
	Conducted Emission	

*Remark : Then, the above highest emission mode of the configuration of the EUT and cable was chosen for all final test items.*

#### Conducted / Radiated Emission Test (Above 1 GHz)

##### IEEE 802.11b, 802.11g, 802.11n HT20 mode

The EUT had been tested under operating condition.

There are three channels have been tested as following :

Channel	Frequency (MHz)
Low	2412
Middle	2437
High	2462

IEEE 802.11b mode : 1Mbps data rate (worst case) were chosen for full testing.

IEEE 802.11g mode : 6Mbps data rate (worst case) were chosen for full testing.

IEEE 802.11n HT20 mode : 6.5Mbps data rate (worst case) were chosen for full testing.



## 4. TEST METHODOLOGY

The tests documented in this report were performed in accordance with ANSI C63.10: 2009 and FCC CFR 47, 15.207, 15.209 and 15.247.

## 5. FACILITIES AND ACCREDITATION

### 5.1 FACILITIES

All measurement facilities used to collect the measurement data are located at

NO. 989-1 Wen Shan Rd., Shang Shan Village,  
Qionglin Shiang Hsinchu County 30741, Taiwan, R.O.C

The sites are constructed in conformance with the requirements of ANSI C63.10:2009 and CISPR 22. All receiving equipment conforms to CISPR 16-1-1, CISPR 16-1-2, CISPR 16-1-3, CISPR 16-1-4, CISPR 16-1-5.

### 5.2 ACCREDITATIONS

Our laboratories are accredited and approved by the following approval agencies according to ISO/IEC 17025.

<b>Taiwan</b>	TAF
---------------	-----

The measuring facility of laboratories has been authorized or registered by the following approval agencies.

<b>Canada</b>	INDUSTRY CANADA
<b>Japan</b>	VCCI
<b>Taiwan</b>	BSMI
<b>USA</b>	FCC MRA

Copies of granted accreditation certificates are available for downloading from our web site, <http://www.ccsrf.com>





### 5.3 MEASUREMENT UNCERTAINTY

The following table is for the measurement uncertainty, which is calculated as per the document CISPR 16-4-2.

PARAMETER	UNCERTAINTY
Semi Anechoic Chamber (966 Chamber_B) / Radiated Emission, 30 to 1000 MHz	+/- 3.97
Semi Anechoic Chamber (966 Chamber_B) / Radiated Emission, 1 to 18GHz	+/- 3.58
Semi Anechoic Chamber (966 Chamber_B) / Radiated Emission, 18 to 26 GHz	+/- 3.59
Semi Anechoic Chamber (966 Chamber_B) / Radiated Emission, 26 to 40 GHz	+/- 3.81
Conducted Emission (Mains Terminals), 9kHz to 30MHz	+/- 2.48

This uncertainty represents an expanded uncertainty expressed at approximately the 95% confidence level using a coverage factor of  $k=2$ .

Consistent with industry standard (e.g. CISPR 22, clause 11, Measurement Uncertainty) determining compliance with the limits shall be base on the results of the compliance measurement. Consequently the measure emissions being less than the maximum allowed emission result in this be a compliant test or passing test.

The acceptable measurement uncertainty value without requiring revision of the compliance statement is base on conducted and radiated emissions being less than  $U_{CISPR}$  which is 3.6dB and 5.2dB respectively. CCS values (called  $U_{Lab}$  in CISPR 16-4-2) is less than  $U_{CISPR}$  as shown in the table above. Therefore, MU need not be considered for compliance.



## 6. SETUP OF EQUIPMENT UNDER TEST

### SUPPORT EQUIPMENT

No.	Product	Manufacturer	Model No.	Serial No.
1	Notebook PC	HP	ProBook 4421s	CNF03242PJ

No.	Signal Cable Description
1	Non-shielded RJ-45 cable, 12m × 1

### SETUP DIAGRAM FOR TESTS

EUT & peripherals setup diagram is shown in appendix setup photos.

### EUT OPERATING CONDITION

#### **RF Mode :**

1. EUT & peripherals setup diagram is shown in appendix setup photos.
2. EUT link console fixture with LAN.
3. Console fixture link to notebook PC.
4. Run HyperTerminal-→Transfer mode : 38400→ Enter the command

TX Mode:

- ⇒ **Tx Data Rate:** 1Mbps Bandwidth 20 (IEEE 802.11b mode)  
6Mbps Bandwidth 20 (IEEE 802.11g mode)  
6.5Mbps Bandwidth 20 (IEEE 802.11n HT20 mode)
- ⇒ **Power control**  
IEEE 802.11b Channel Low (2412MHz) TX Power 27  
Key in-> #ate-tool tx 100000000 0 0 32 0 0 1 27  
IEEE 802.11b Channel Mid (2437MHz) TX Power 28  
Key in-> # ate-tool tx 100000000 0 0 32 0 0 6 28  
IEEE 802.11b Channel High (2462MHz) TX Power 30  
Key in-> # ate-tool tx 100000000 0 0 32 0 0 11 30  
IEEE 802.11g Channel Low (2412MHz) TX Power 19  
Key in-> # ate-tool tx 100000000 0 0 32 0 1 1 19  
IEEE 802.11g Channel Mid (2437MHz) TX Power 19  
Key in-> # ate-tool tx 100000000 0 0 32 0 1 6 19  
IEEE 802.11g Channel High (2462MHz) TX Power 17  
Key in-> # ate-tool tx 100000000 0 0 32 0 1 11 17



IEEE 802.11n HT20 Channel Low (2412MHz) TX Power 08

Key in-> # ate-tool tx 100000000 0 0 32 0 2 1 08

IEEE 802.11n HT20 Channel Mid (2437MHz) TX Power 18

Key in-> # ate-tool tx 100000000 0 0 32 0 2 6 18

IEEE 802.11n HT20 Channel High (2462MHz) TX Power 14

Key in-> # ate-tool tx 100000000 0 0 32 0 2 11 14

5. All of the functions are under run.

6. Start test.

**Normal Mode :**

All the equipment/cables were placed in the worst-case configuration to maximize the emission during the test. Grounding was established in accordance with the manufacturer's requirements and conditions for the intended use.

1. EUT & peripherals setup diagram is shown in appendix setup photos.

2. Notebook link to EUT by WiFi.

3. All of the functions are under run (Web display video).

4. Start test.



## 7. FCC PART 15.247 REQUIREMENTS

### 7.1 6dB BANDWIDTH

#### LIMITS

§ 15.247(a) (2) For direct sequence systems, the minimum 6dB bandwidth shall be at least 500kHz.

#### TEST EQUIPMENT

Name of Equipment	Manufacturer	Model	Serial Number	Calibration Due
Spectrum Analyzer	Agilent	E4446A	MY43360132	06/10/2014

*Remark: Each piece of equipment is scheduled for calibration once a year.*

#### TEST SETUP



#### TEST PROCEDURE

1. The transmitter output was connected to a spectrum analyzer.
2. Set RBW = 100 kHz.
3. Set the video bandwidth (VBW)  $\geq 3 \times$  RBW.
4. Detector = Peak.
5. Trace mode = max hold.
6. Sweep = auto couple.
7. Allow the trace to stabilize.
8. Measure the maximum width of the emission that is constrained by the frequencies associated with the two outermost amplitude points (upper and lower frequencies) that are attenuated by 6 dB relative to the maximum level measured in the fundamental emission.



**TEST RESULTS**

**IEEE 802.11b Mode**

Channel	Channel Frequency (MHz)	6dB Bandwidth (MHz)	Minimum Limit (kHz)	Pass / Fail
Low	2412	10.160	500	PASS
Middle	2437	10.150	500	PASS
High	2462	10.155	500	PASS

**IEEE 802.11g Mode**

Channel	Channel Frequency (MHz)	6dB Bandwidth (MHz)	Minimum Limit (kHz)	Pass / Fail
Low	2412	15.760	500	PASS
Middle	2437	15.690	500	PASS
High	2462	15.470	500	PASS

**IEEE 802.11n HT20 Mode**

Channel	Channel Frequency (MHz)	6dB Bandwidth (MHz)	Minimum Limit (kHz)	Pass / Fail
Low	2412	15.340	500	PASS
Middle	2437	15.460	500	PASS
High	2462	15.460	500	PASS



**6dB BANDWIDTH**

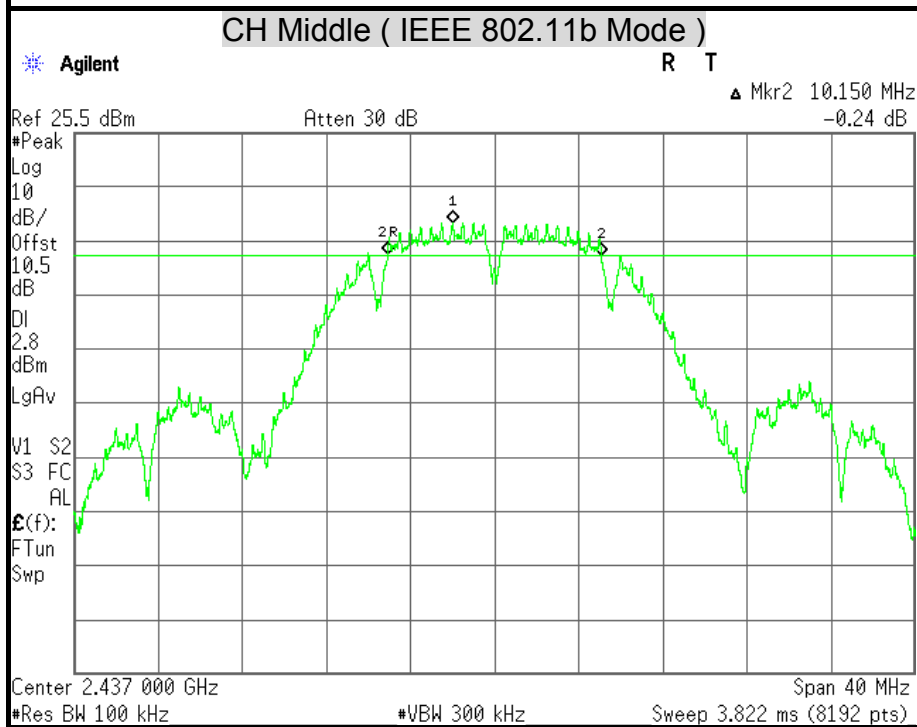
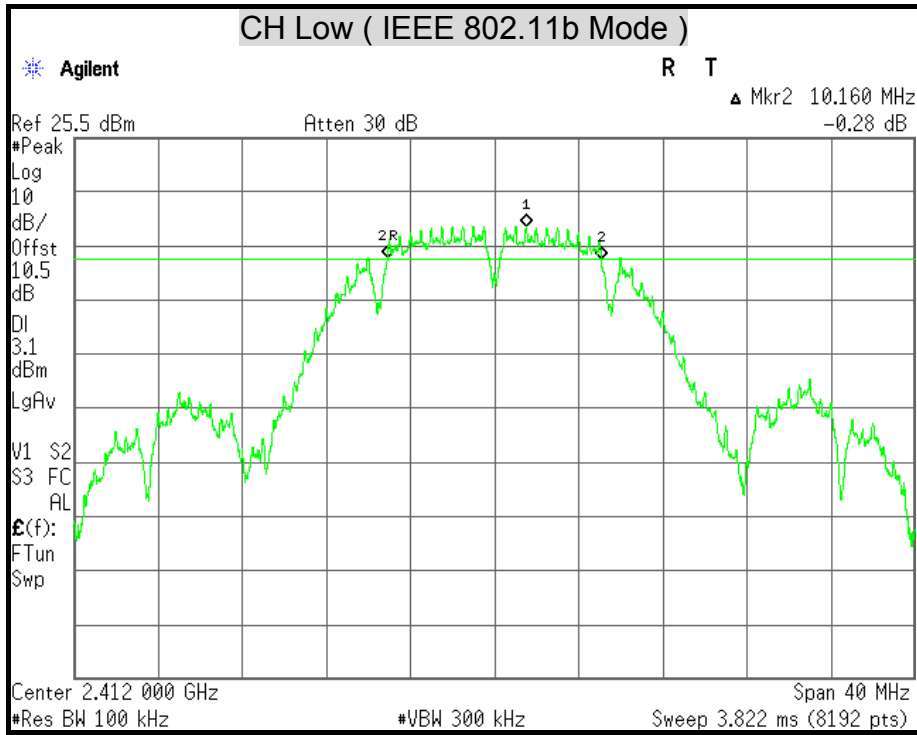

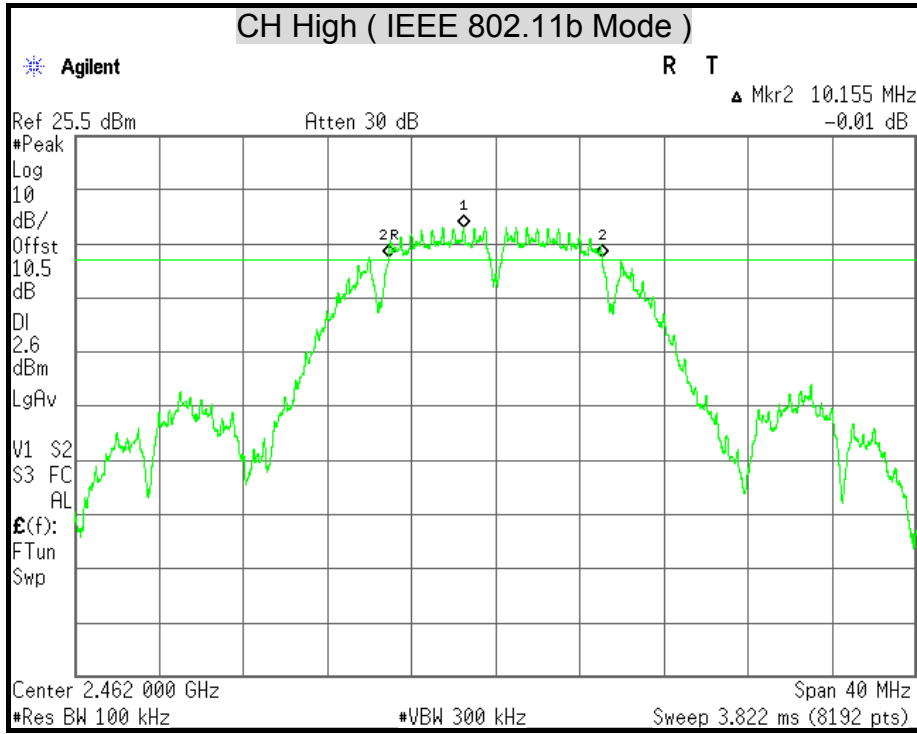

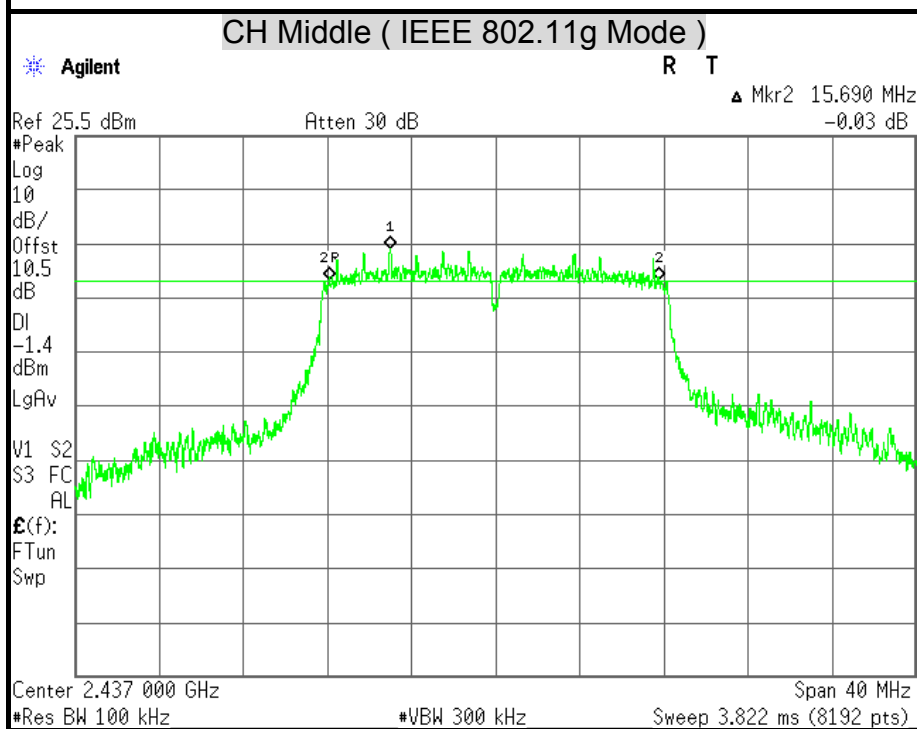
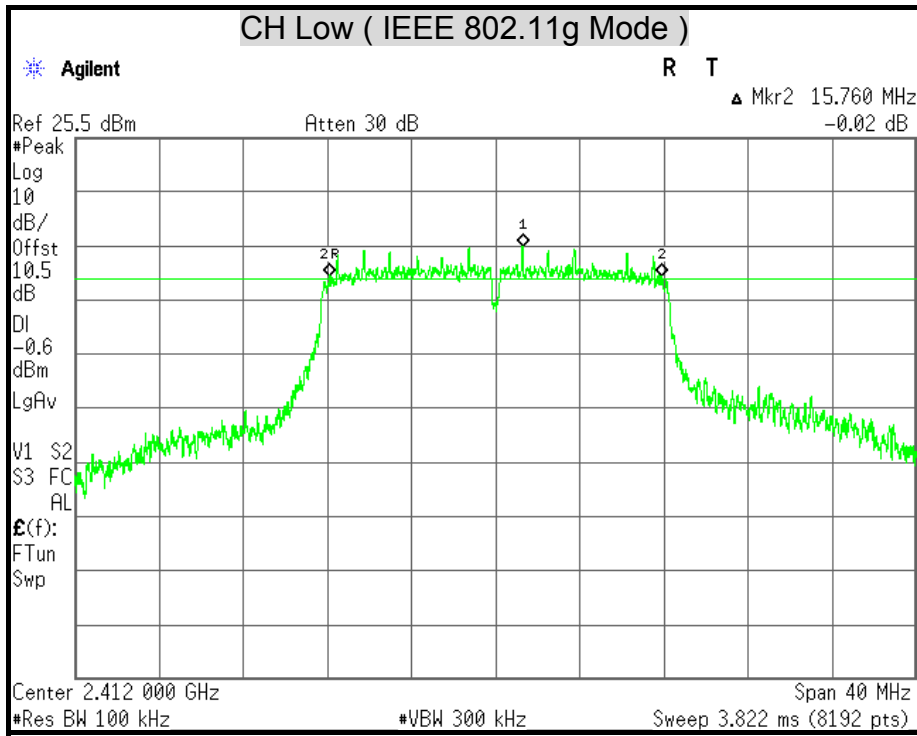



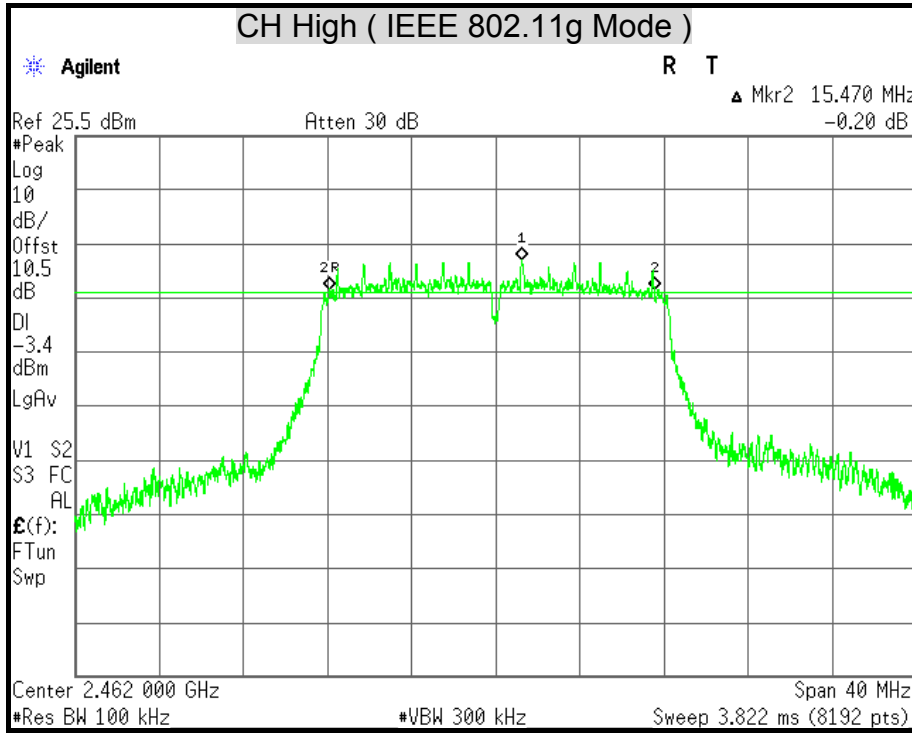

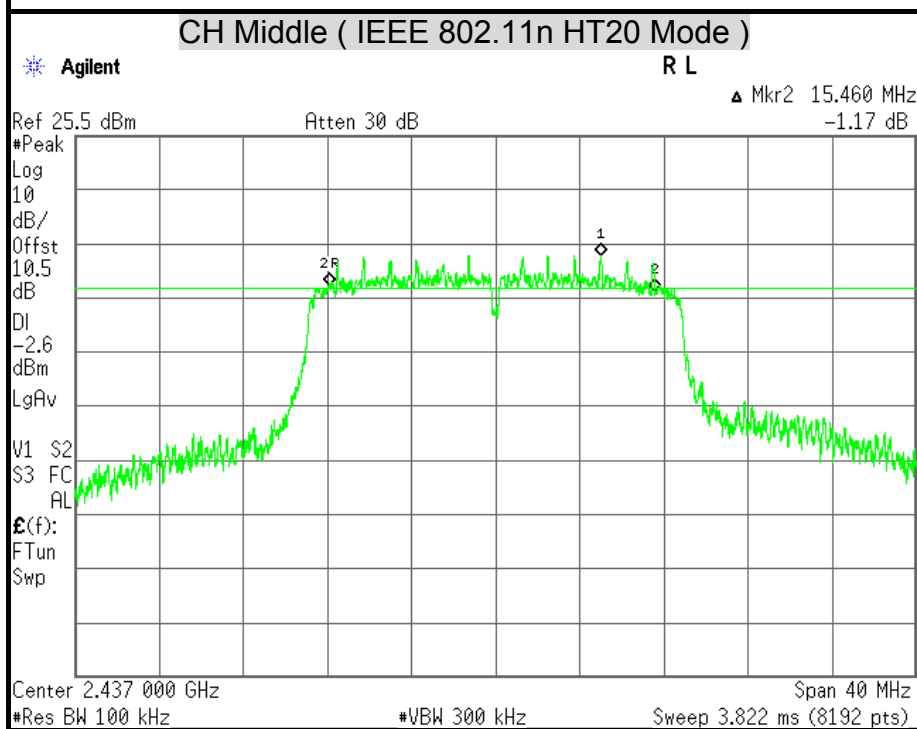
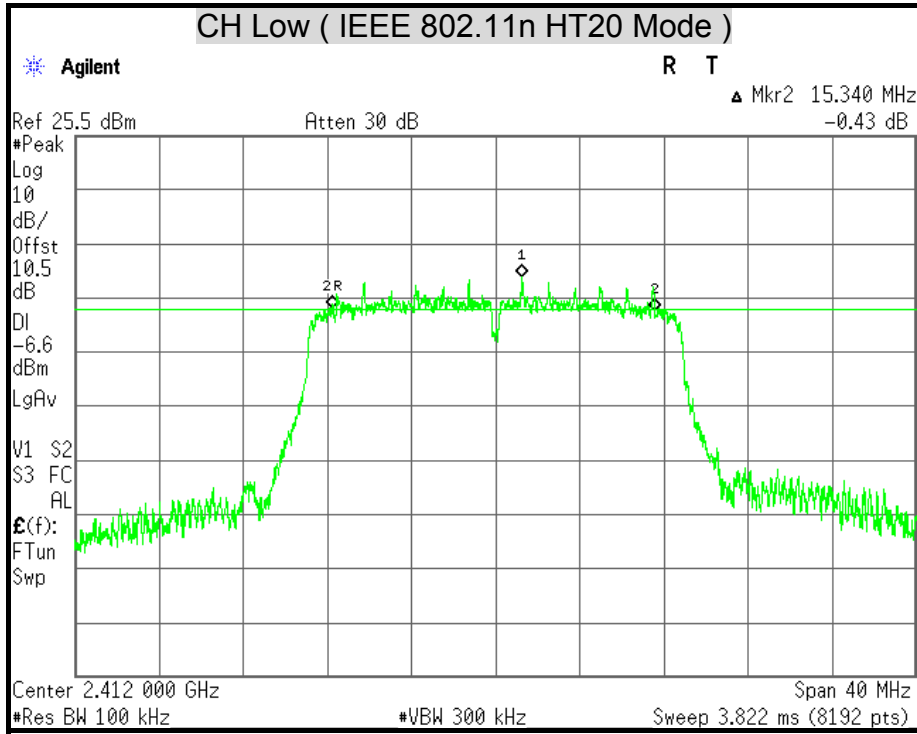

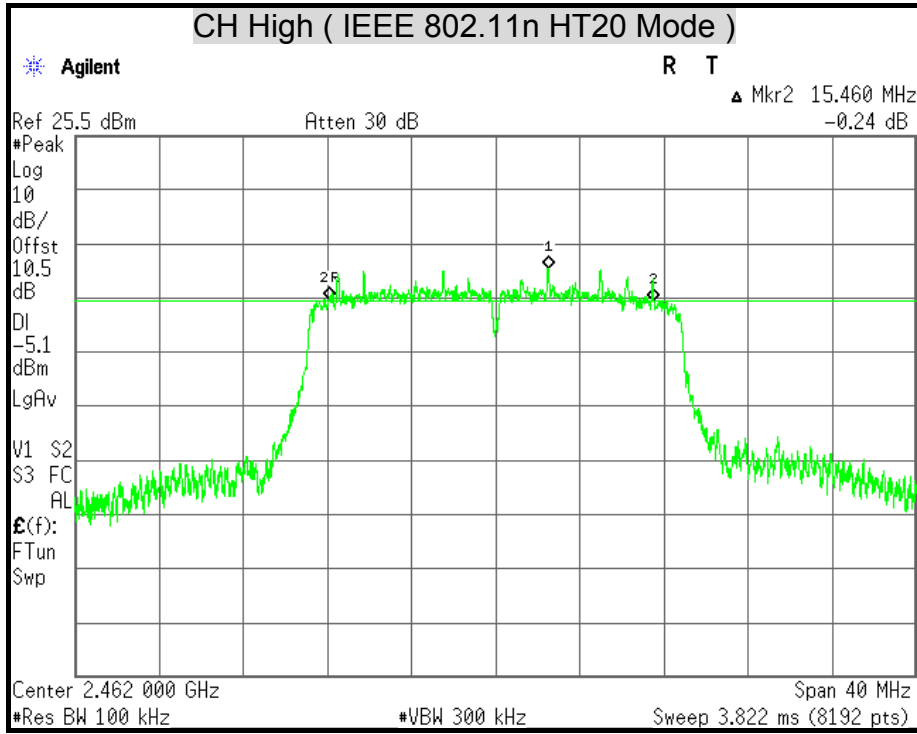



## 7.2 MAXIMUM PEAK OUTPUT POWER

### LIMITS

§ 15.247(b) The maximum peak output power of the intentional radiator shall not exceed the following :

§ 15.247(b) (3) For systems using digital modulation in the 902-928 MHz, 2400-2483.5 MHz, and 5725-5850 MHz bands : 1 watt.

§ 15.247(b) (4) Except as shown in paragraphs (c) of this section, if transmitting antennas of directional gain greater than 6 dBi are used the peak output power from the intentional radiator shall be reduced below the stated values in paragraphs (b)(1) or (b)(2), and (b)(3) of this section, as appropriate, by the amount in dB that the directional gain of the antenna exceeds 6 dBi.

### TEST EQUIPMENT

Name of Equipment	Manufacturer	Model	Serial Number	Calibration Due
Power Meter	Anritsu	ML2495A	1149001	12/06/2014
Power Sensor	Anritsu	MA2411B	1126148	12/06/2014

*Remark: Each piece of equipment is scheduled for calibration once a year.*

### TEST SETUP

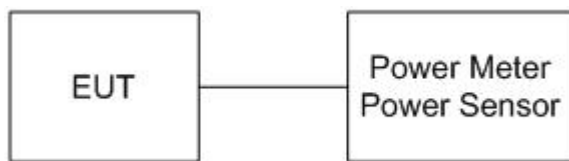

### TEST PROCEDURE

The transmitter output is connected to the power meter. The power meter is set to the peak power detection.



**TEST RESULTS**

**IEEE 802.11b Mode**

Channel	Channel Frequency (MHz)	Peak Power		Peak Power Limit		Pass / Fail
		(dBm)	(W)	(dBm)	(W)	
Low	2412	22.57	0.1809	30	1	PASS
Middle	2437	22.19	0.1656	30	1	PASS
High	2462	22.05	0.1601	30	1	PASS

**Remark:**

1. At final test to get the worst-case emission at 1Mbps.
2. The cable assembly insertion loss of 11.5 dB (including 10 dB pad and 1.5 dB cable) was Entered as an offset in the power meter to allow for direct reading of power.

**IEEE 802.11g Mode**

Channel	Channel Frequency (MHz)	Peak Power		Peak Power Limit		Pass / Fail
		(dBm)	(W)	(dBm)	(W)	
Low	2412	23.87	0.2439	30	1	PASS
Middle	2437	23.59	0.2283	30	1	PASS
High	2462	21.67	0.1469	30	1	PASS

**Remark:**

1. At final test to get the worst-case emission at 6Mbps.
2. The cable assembly insertion loss of 11.5 dB (including 10 dB pad and 1.5 dB cable) was Entered as an offset in the power meter to allow for direct reading of power.

**IEEE 802.11n HT20 Mode**

Channel	Channel Frequency (MHz)	Peak Power		Peak Power Limit		Pass / Fail
		(dBm)	(W)	(dBm)	(W)	
Low	2412	18.51	0.0710	30	1	PASS
Middle	2437	22.88	0.1940	30	1	PASS
High	2462	20.22	0.1052	30	1	PASS

**Remark:**

1. At final test to get the worst-case emission at 6.5Mbps.
2. The cable assembly insertion loss of 11.5 dB (including 10 dB pad and 1.5 dB cable) was Entered as an offset in the power meter to allow for direct reading of power.



### 7.3 AVERAGE POWER

#### LIMITS

None; for reporting purposes only.

#### TEST EQUIPMENT

Name of Equipment	Manufacturer	Model	Serial Number	Calibration Due
Power Meter	ANRITSU	ML2495A	1149001	12/06/2014
Power Sensor	ANRITSU	MA2411B	1126148	12/06/2014

*Remark: Each piece of equipment is scheduled for calibration once a year.*

#### TEST SETUP



#### TEST PROCEDURE

The transmitter output is connected to the power meter. The power meter is set to the average power detection.



**TEST RESULTS**

**IEEE 802.11b Mode**

Channel	Channel Frequency (MHz)	Average Power (dBm)
Low	2412	19.43
Middle	2437	19.01
High	2462	18.90

**Remark:**

1. At final test to get the worst-case emission at 1Mbps.
2. The cable assembly insertion loss of 11.5 dB (including 10 dB pad and 1.5 dB cable) was Entered as an offset in the power meter to allow for direct reading of power.

**IEEE 802.11g Mode**

Channel	Channel Frequency (MHz)	Average Power (dBm)
Low	2412	15.99
Middle	2437	15.84
High	2462	13.94

**Remark:**

1. At final test to get the worst-case emission at 6Mbps.
2. The cable assembly insertion loss of 11.5 dB (including 10 dB pad and 1.5 dB cable) was Entered as an offset in the power meter to allow for direct reading of power.

**IEEE 802.11n HT20 Mode**

Channel	Channel Frequency (MHz)	Average Power (dBm)
Low	2412	10.58
Middle	2437	14.86
High	2462	12.21

**Remark:**

1. At final test to get the worst-case emission at 6.5Mbps.
2. The cable assembly insertion loss of 11.5 dB (including 10 dB pad and 1.5 dB cable) was Entered as an offset in the power meter to allow for direct reading of power.



## 7.4 POWER SPECTRAL DENSITY

### LIMITS

§ 15.247(e) For digitally modulated systems, the power spectral density conducted from the intentional radiator to the antenna shall not greater than 8 dBm in any 3 kHz band during any time interval of continuous transmission.

### TEST EQUIPMENT

Name of Equipment	Manufacturer	Model	Serial Number	Calibration Due
Spectrum Analyzer	Agilent	E4446A	MY43360132	06/10/2014

*Remark: Each piece of equipment is scheduled for calibration once a year.*

### TEST SETUP



### TEST PROCEDURE

1. The transmitter output was connected to the spectrum analyzer.
2. Set analyzer center frequency to DTS channel center frequency.
3. Set the span to 1.5 times the DTS channel bandwidth.
4. Set the RBW to:  $3 \text{ kHz} \leq \text{RBW} \leq 100 \text{ kHz}$ .
5. Set the VBW  $\geq 3 \times \text{RBW}$ .
6. Detector = peak.
7. Sweep time = auto couple.
8. Trace mode = max hold.
9. Allow trace to fully stabilize.
10. Use the peak marker function to determine the maximum amplitude level within the RBW.
11. If measured value exceeds limit, reduce RBW (no less than 3 kHz) and repeat.





**TEST RESULTS**

**IEEE 802.11b Mode**

Channel	Channel Frequency (MHz)	Final RF Power Level in 3KHz BW (dBm)	Minimum Limit (dBm)	Pass / Fail
Low	2412	-6.83	8	PASS
Middle	2437	-6.87	8	PASS
High	2462	-6.77	8	PASS

**Remark:**

1. At final test to get the worst-case emission at 1Mbps.
2. The cable assembly insertion loss of 10.5 dB (including 10 dB pad and 0.5 dB cable) was Entered as an offset in the spectrum analyzer to allow for direct reading of power.

**IEEE 802.11g Mode**

Channel	Channel Frequency (MHz)	Final RF Power Level in 3KHz BW (dBm)	Minimum Limit (dBm)	Pass / Fail
Low	2412	-10.69	8	PASS
Middle	2437	-12.29	8	PASS
High	2462	-14.18	8	PASS

**Remark:**

1. At final test to get the worst-case emission at 6Mbps.
2. The cable assembly insertion loss of 10.5 dB (including 10 dB pad and 0.5 dB cable) was Entered as an offset in the spectrum analyzer to allow for direct reading of power.

**IEEE 802.11n HT20 Mode**

Channel	Channel Frequency (MHz)	Final RF Power Level in 3KHz BW (dBm)	Minimum Limit (dBm)	Pass / Fail
Low	2412	-16.73	8	PASS
Middle	2437	-12.83	8	PASS
High	2462	-15.51	8	PASS

**Remark:**

1. At final test to get the worst-case emission at 6.5Mbps.
2. The cable assembly insertion loss of 10.5 dB (including 10 dB pad and 0.5 dB cable) was Entered as an offset in the spectrum analyzer to allow for direct reading of power.



**POWER SPECTRAL DENSITY**

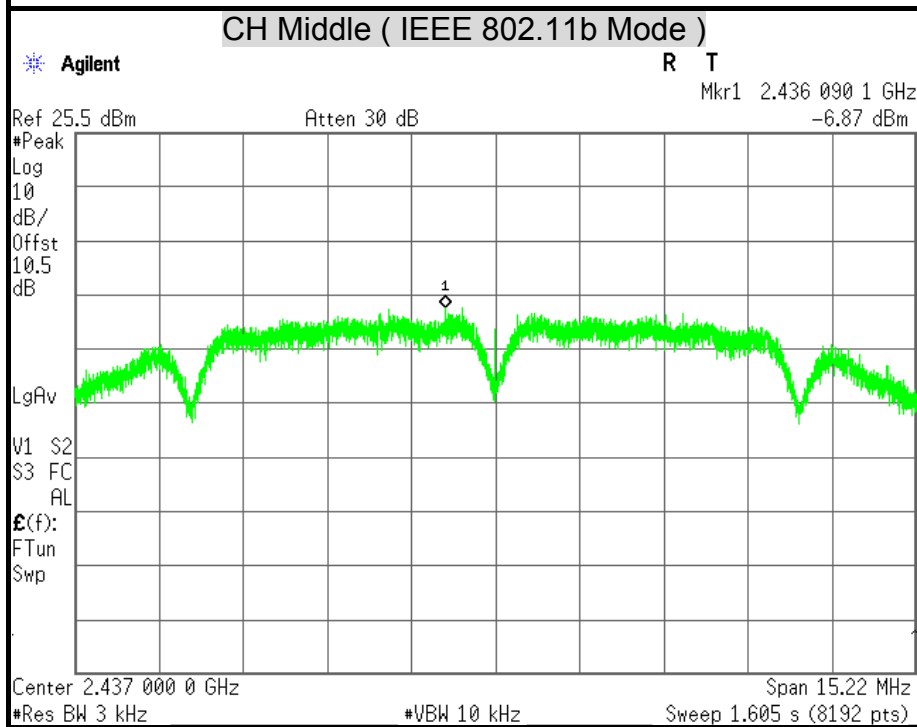
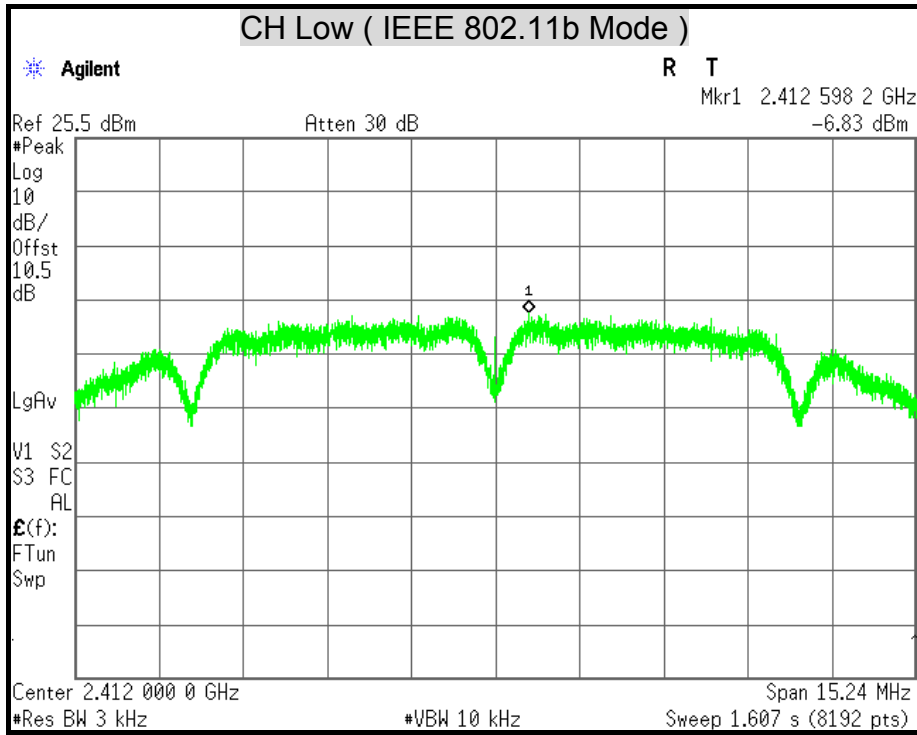

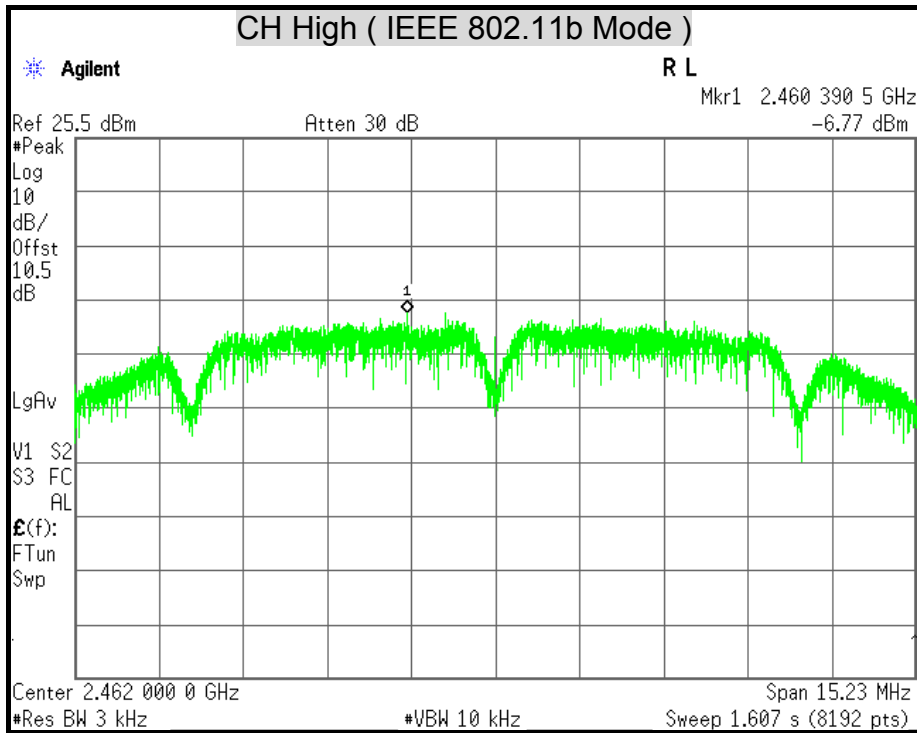

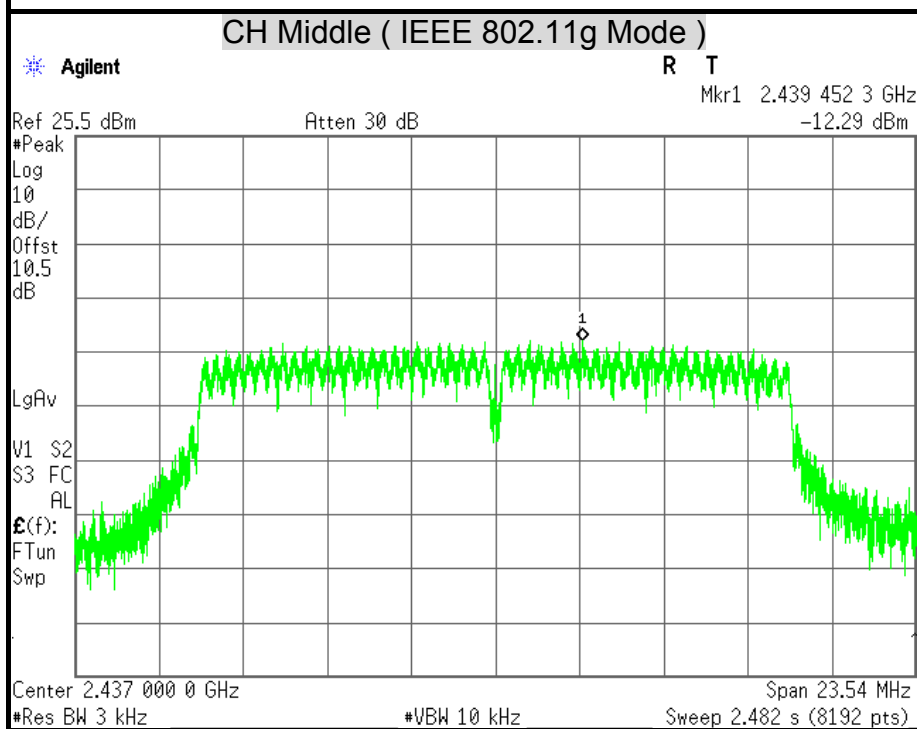
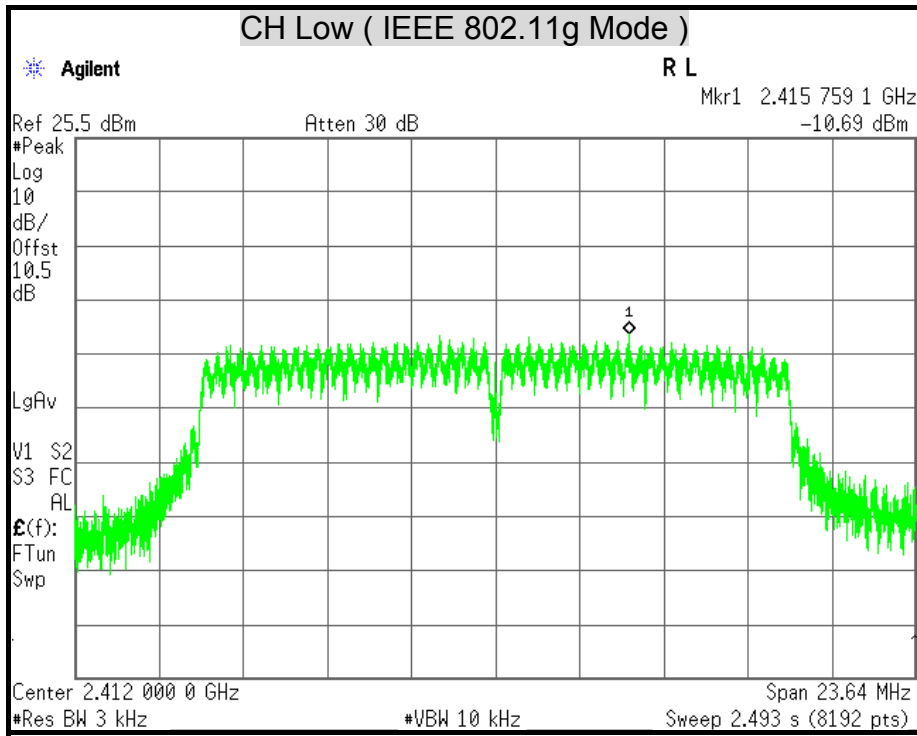

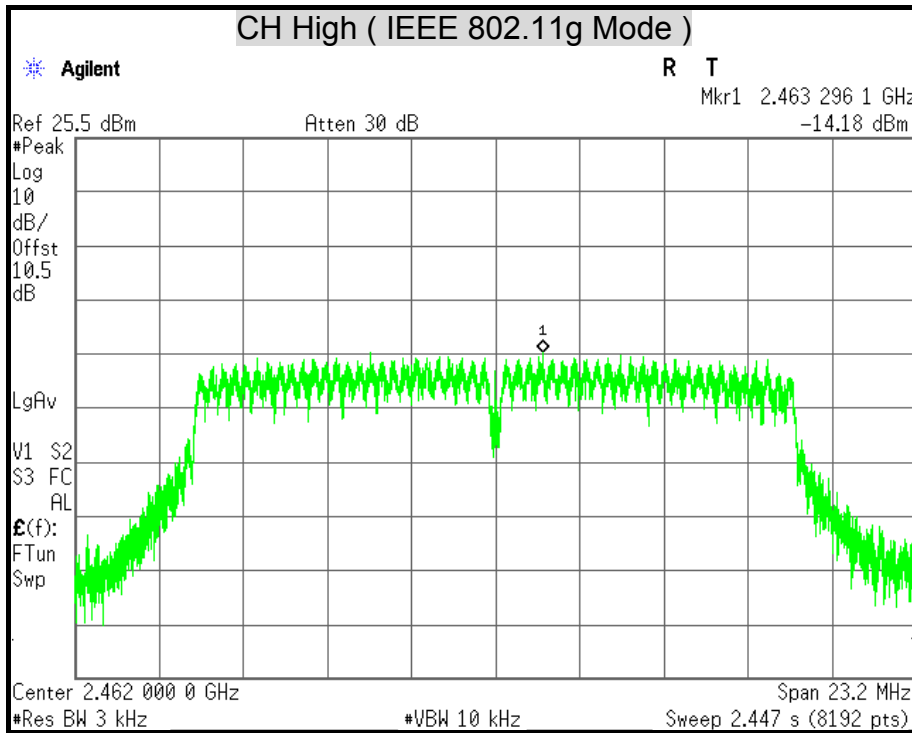

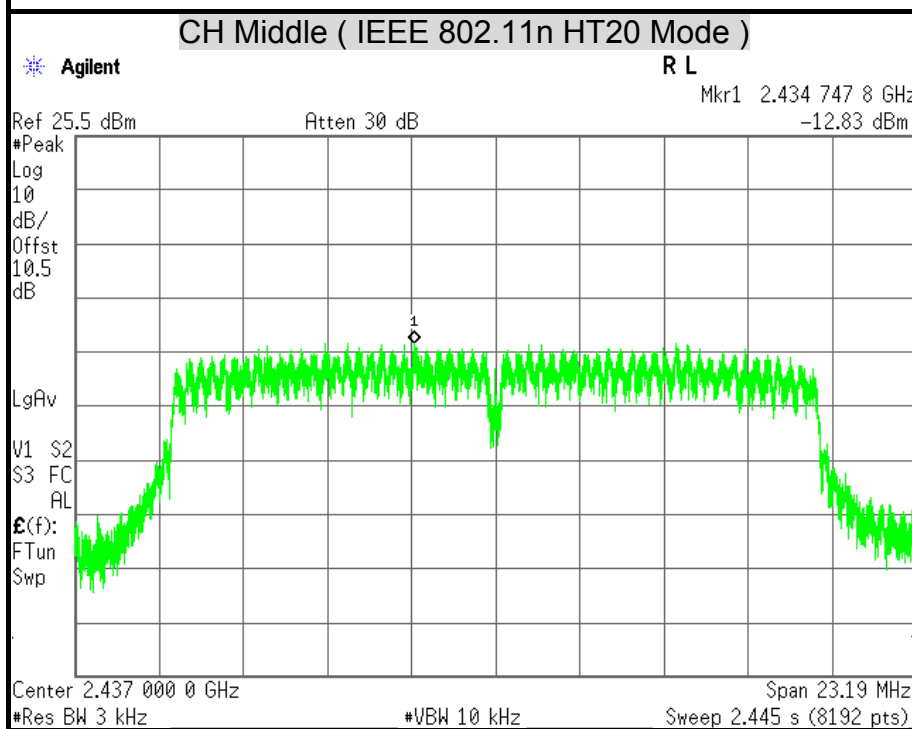
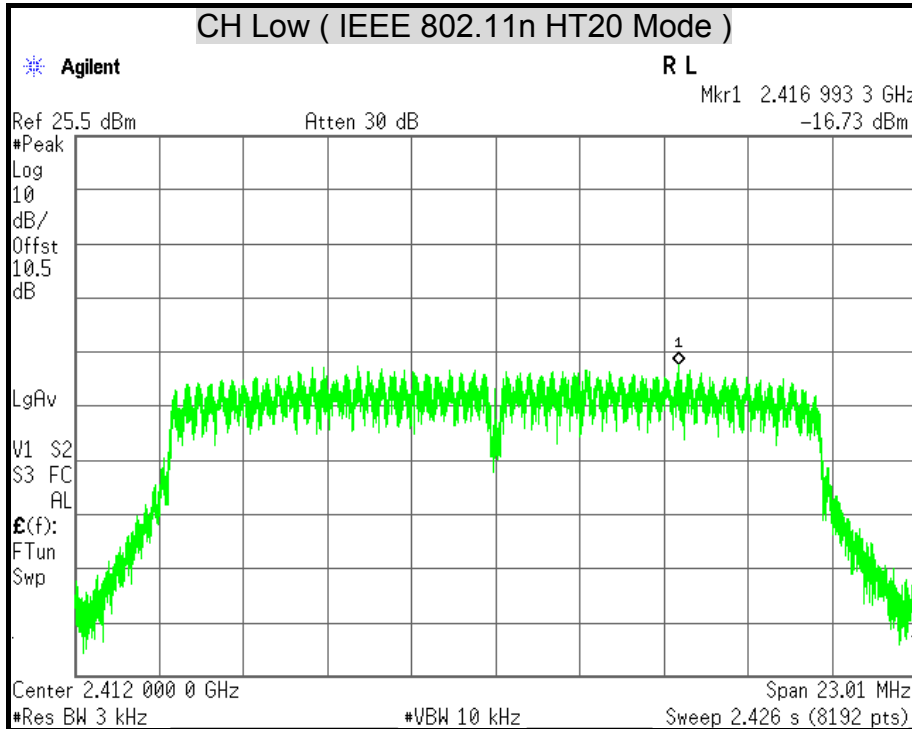

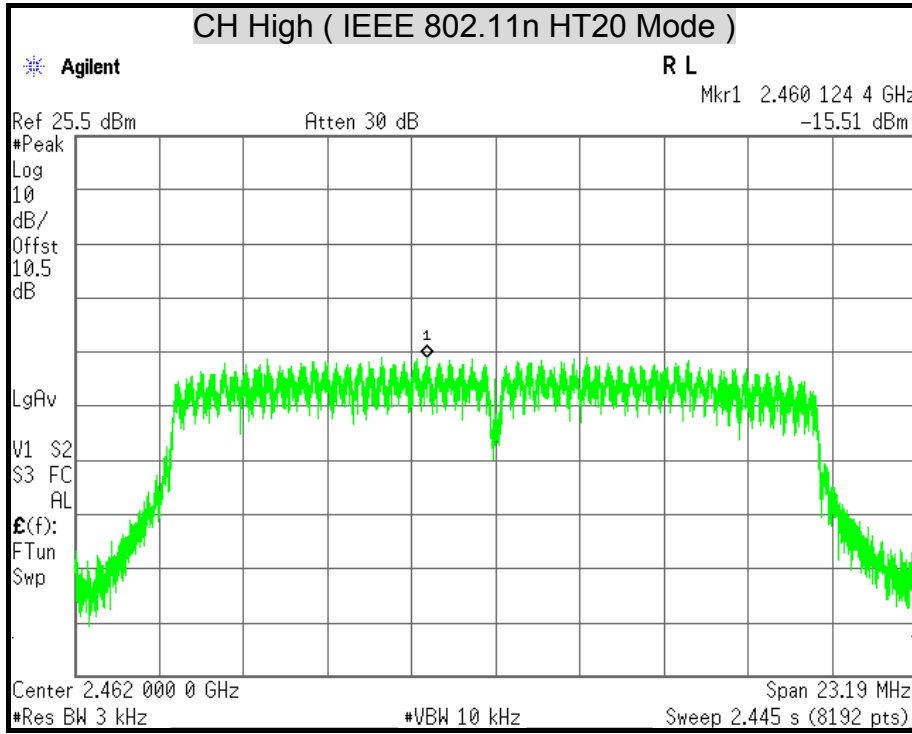



### 7.5 CONDUCTED SPURIOUS EMISSION

#### LIMITS

§ 15.247(d) In any 100 kHz bandwidth outside the frequency band in which the spread spectrum intentional radiator is operating, the radio frequency power that is produced by the intentional radiator shall be at least 20 dB below that in the 100 kHz bandwidth within the band that contains the highest level of the desired power, based on either an RF conducted or a radiated measurement. Attenuation below the general limits specified in § 15.209(a) is not required. In addition, radiated emissions which fall in the restricted bands, as defined in § 15.205(a), must also comply with the radiated emission limits specified in § 15.209(a) (see § 15.205(c)).

#### TEST EQUIPMENT

Name of Equipment	Manufacturer	Model	Serial Number	Calibration Due
Spectrum Analyzer	Agilent	E4446A	MY43360132	06/10/2014

*Remark: Each piece of equipment is scheduled for calibration once a year.*

#### TEST SETUP



#### TEST PROCEDURE

The transmitter output is connected to a spectrum analyzer. The resolution bandwidth is set to 100 kHz. The video bandwidth is set to 300 kHz.

The spectrum from 30 MHz to 26.5 GHz is investigated with the transmitter set to the lowest, middle, and highest channels in the 2.4 GHz band.





TEST RESULTS

OUT-OF-BAND SPURIOUS EMISSIONS-CONDUCTED MEASUREMENT

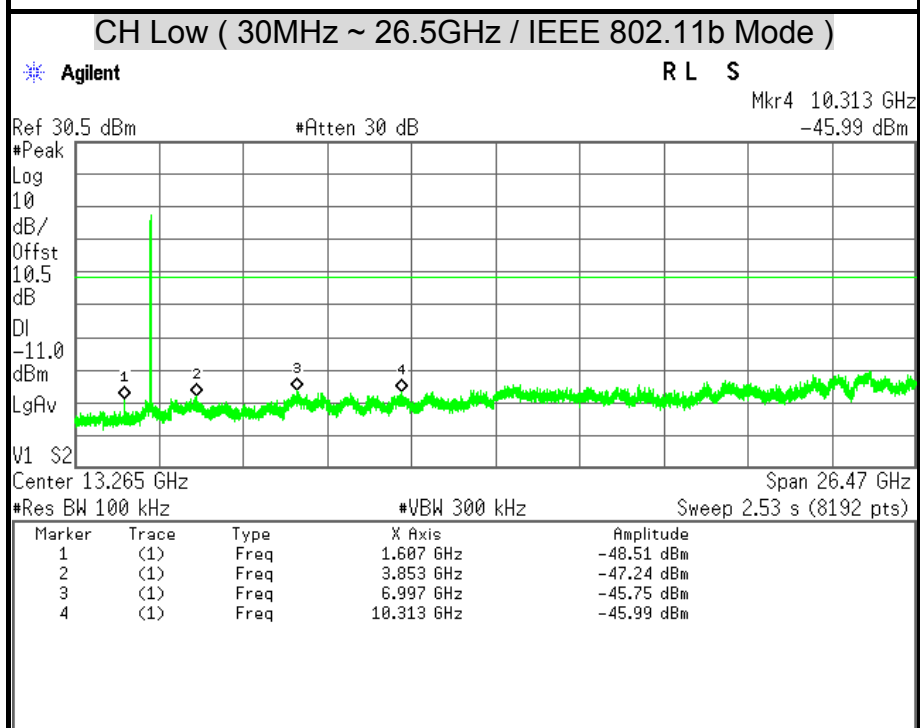
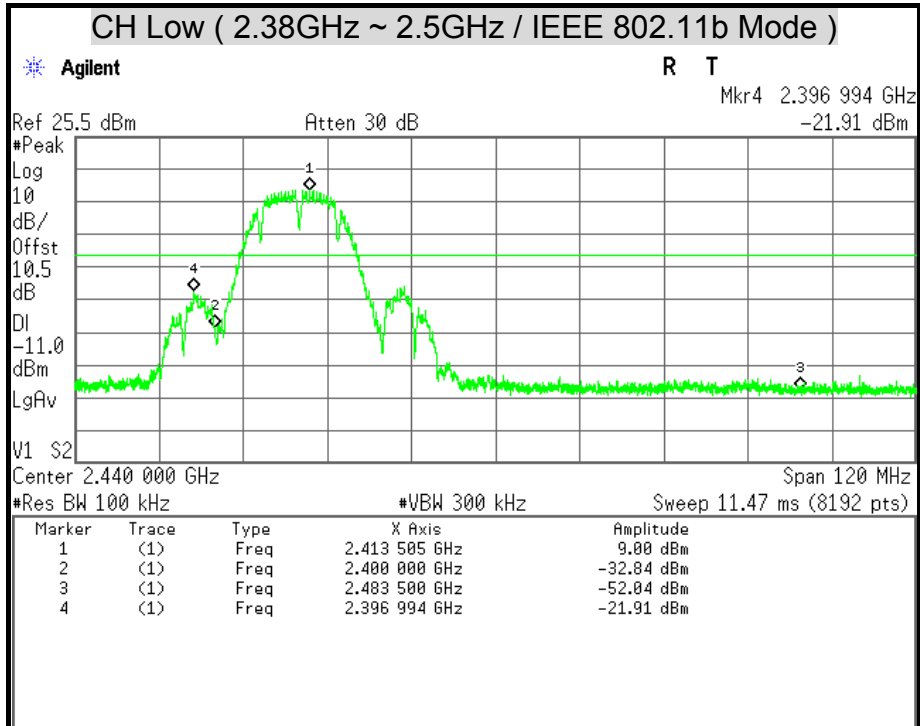

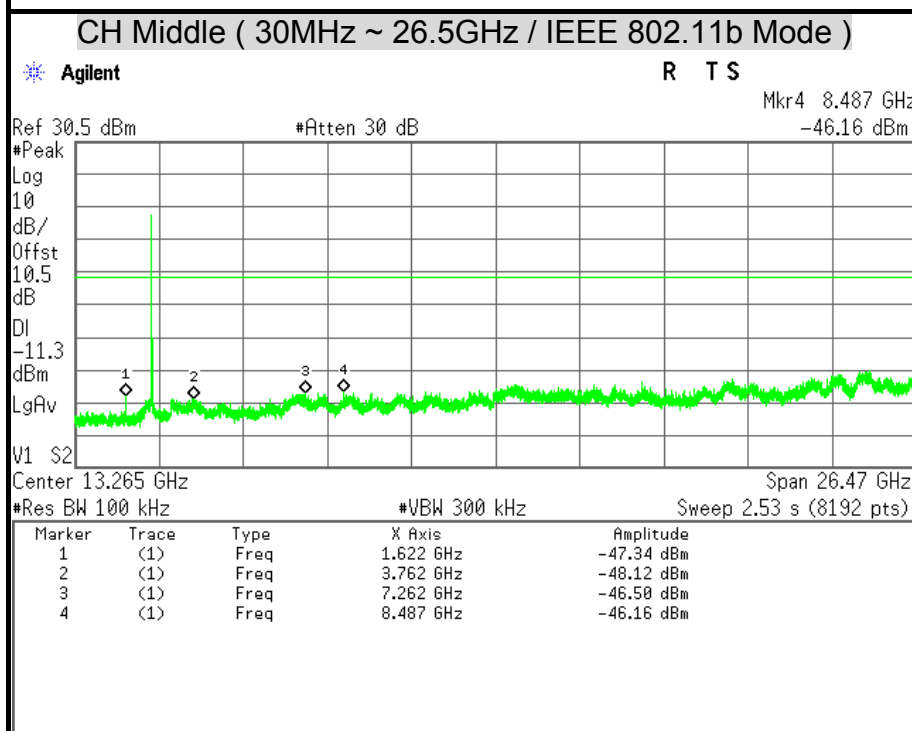
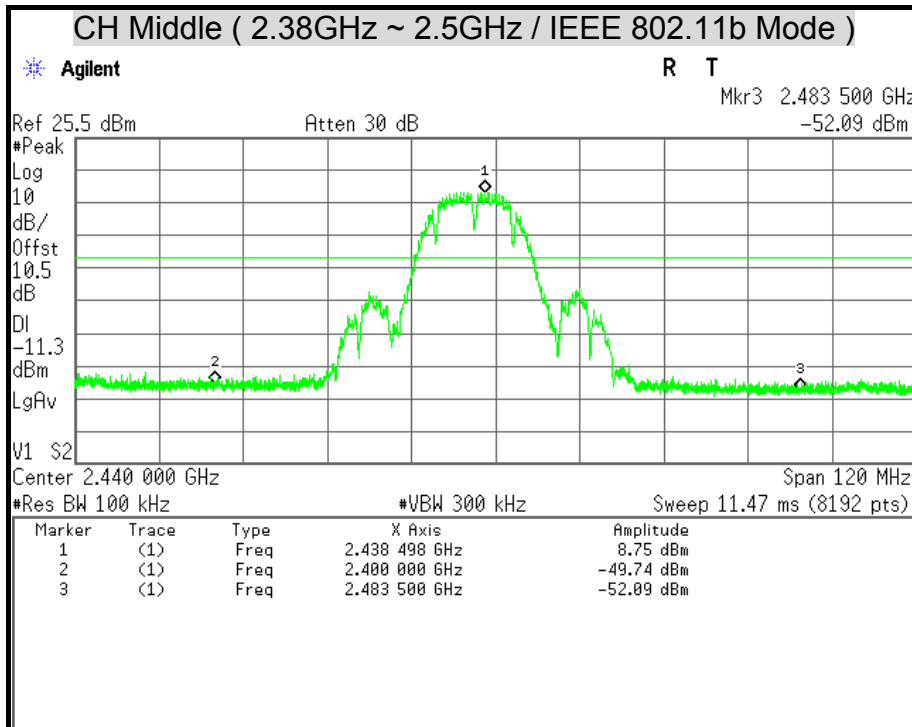

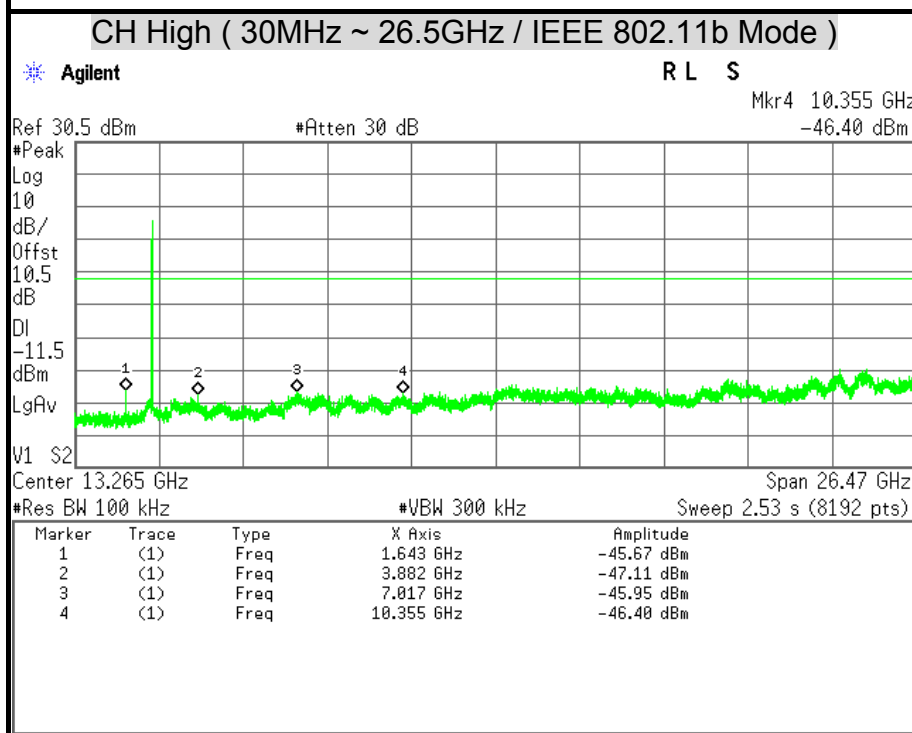
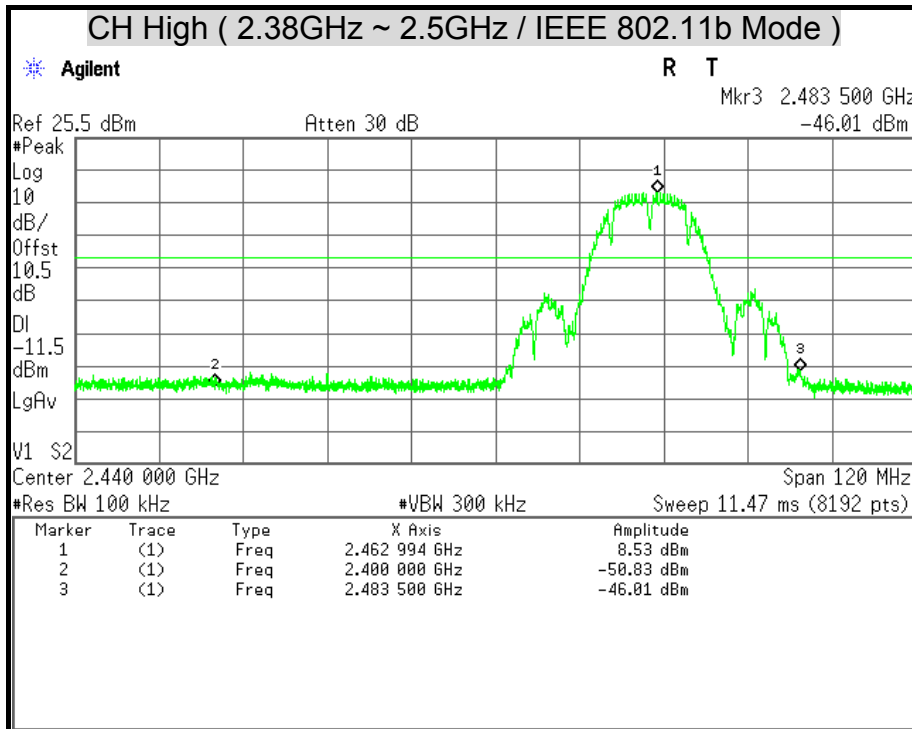

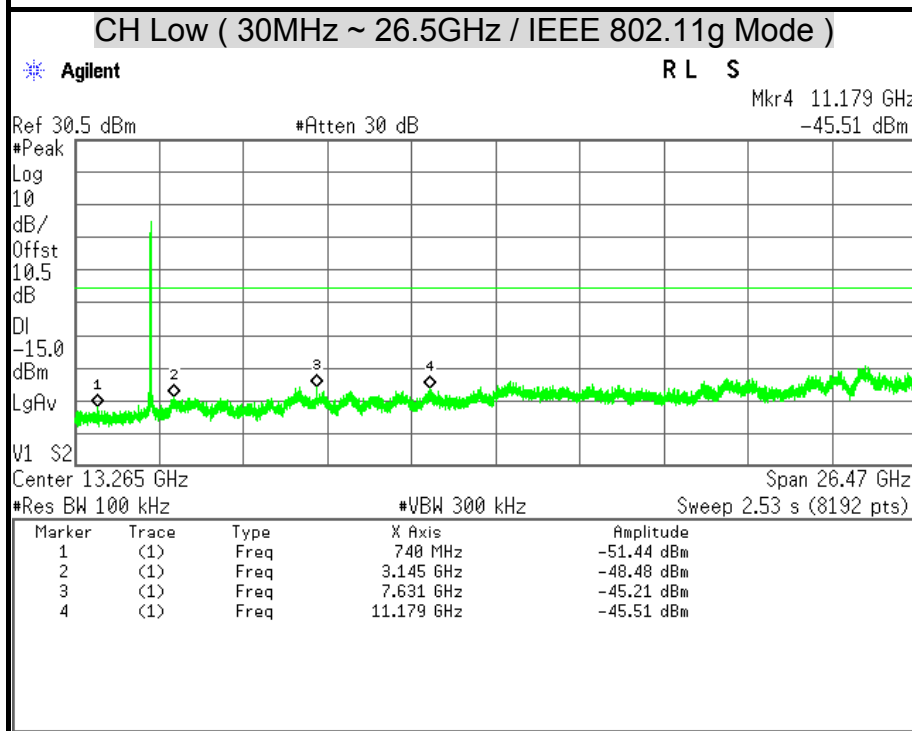
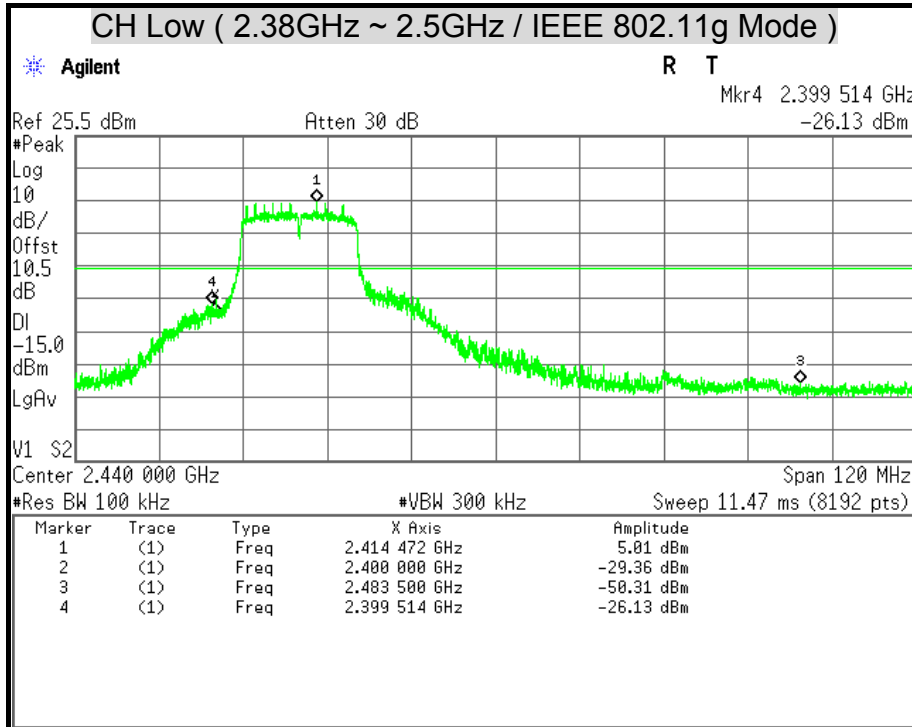

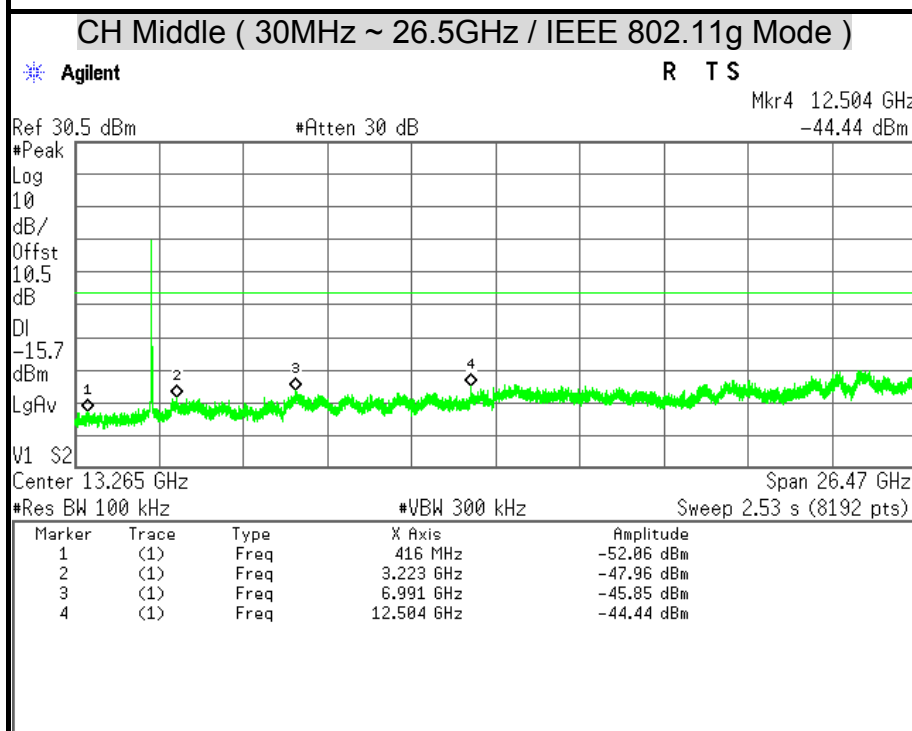
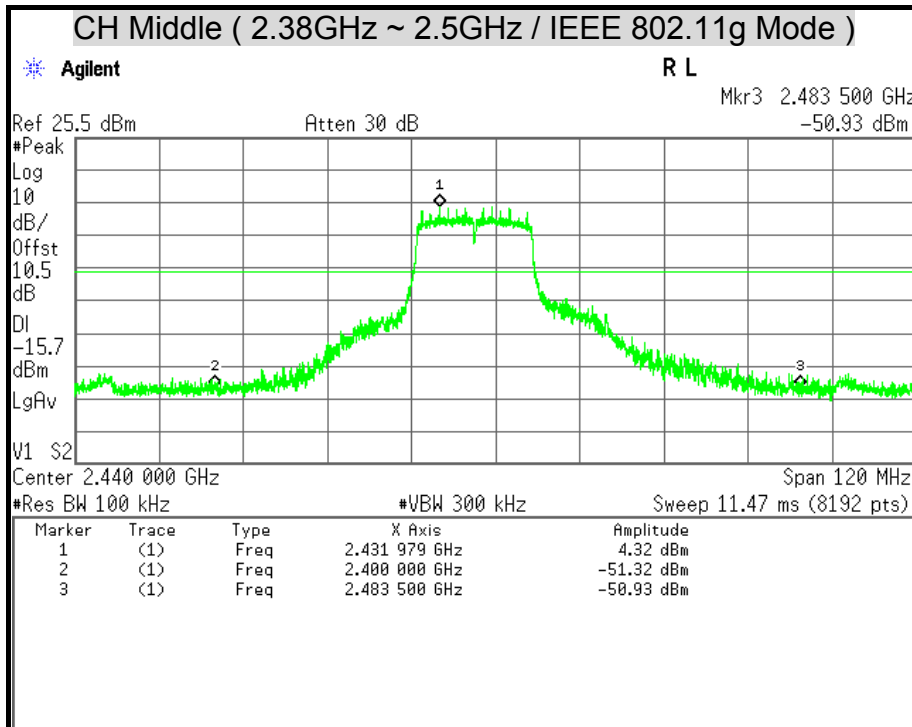

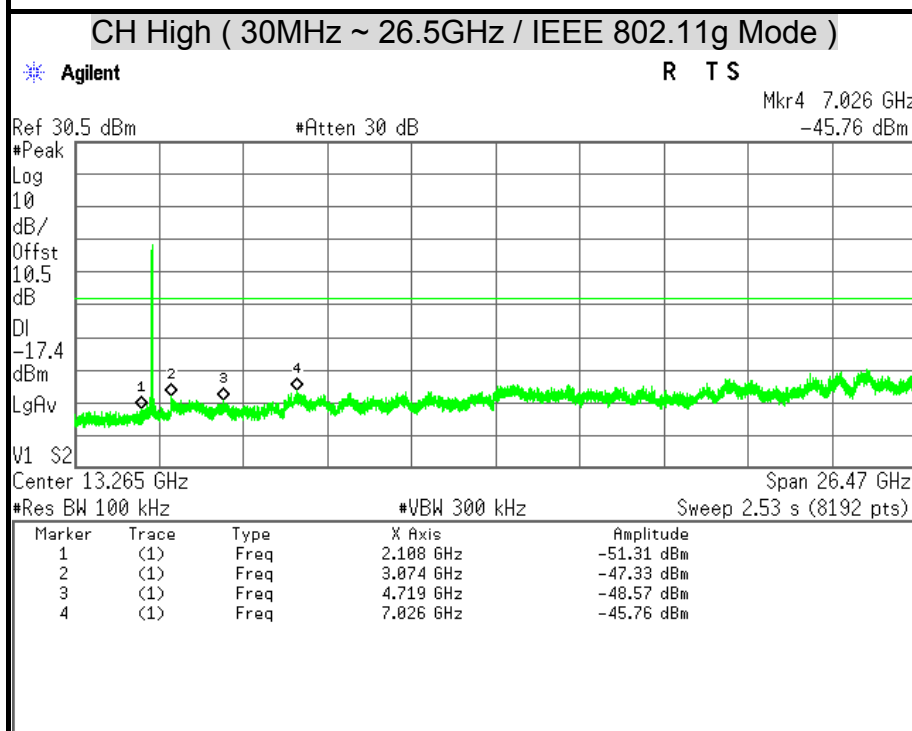
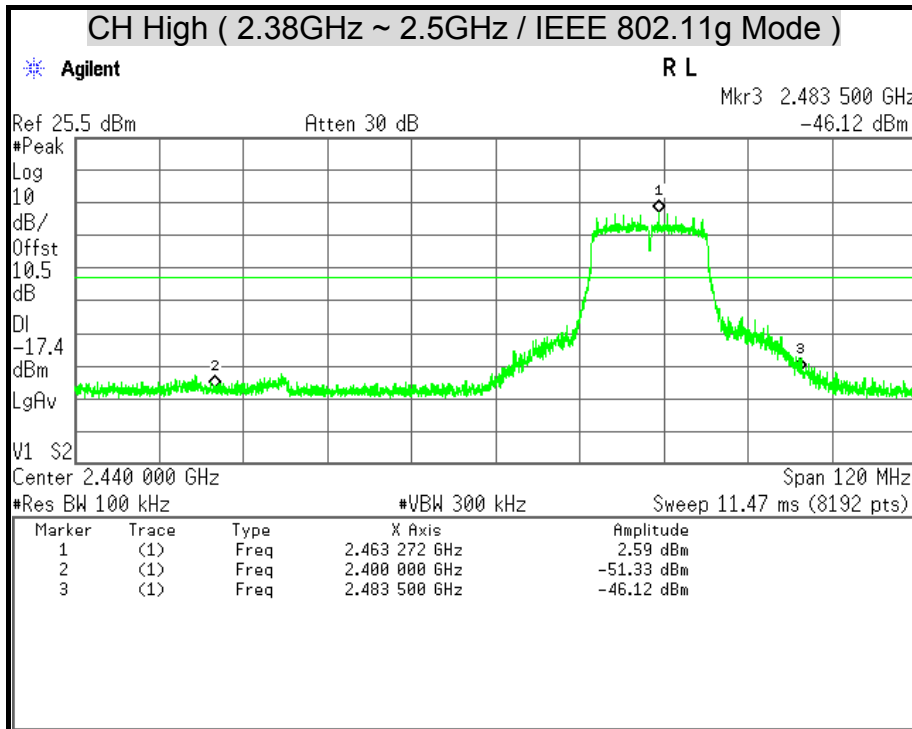

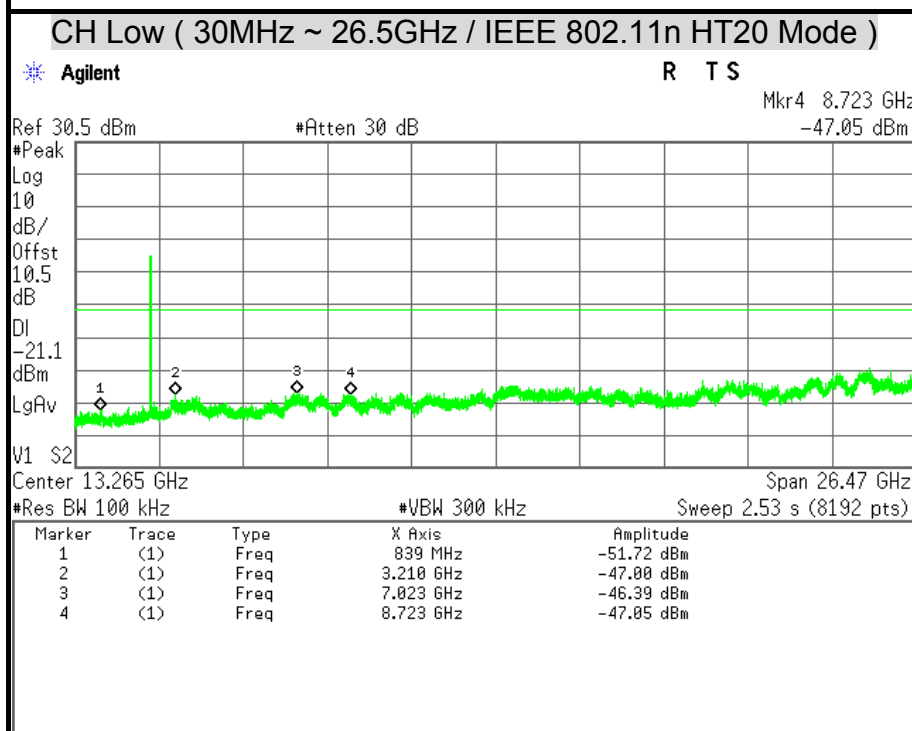
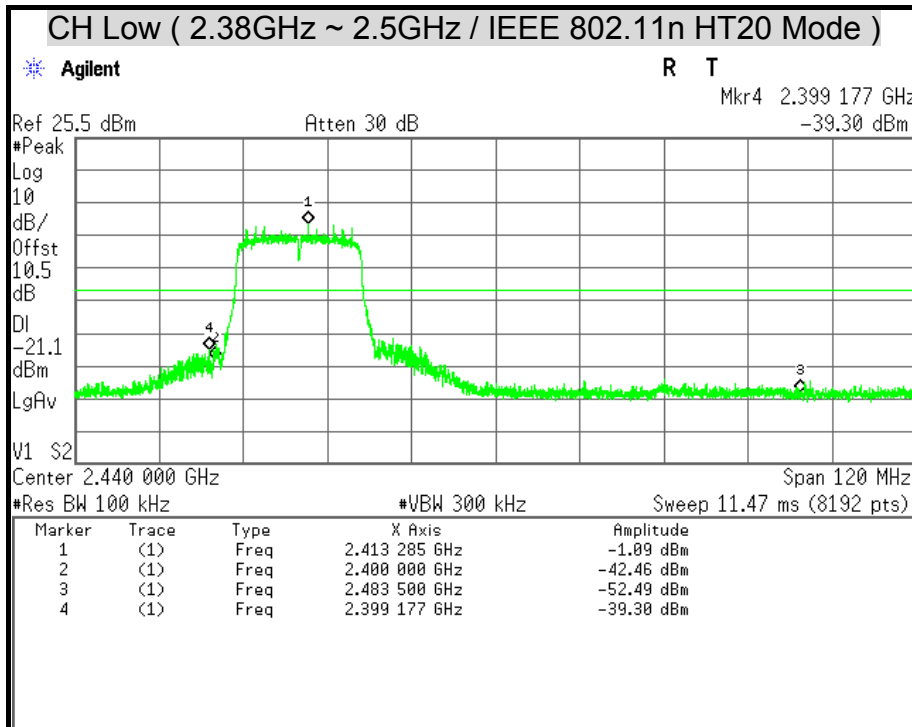

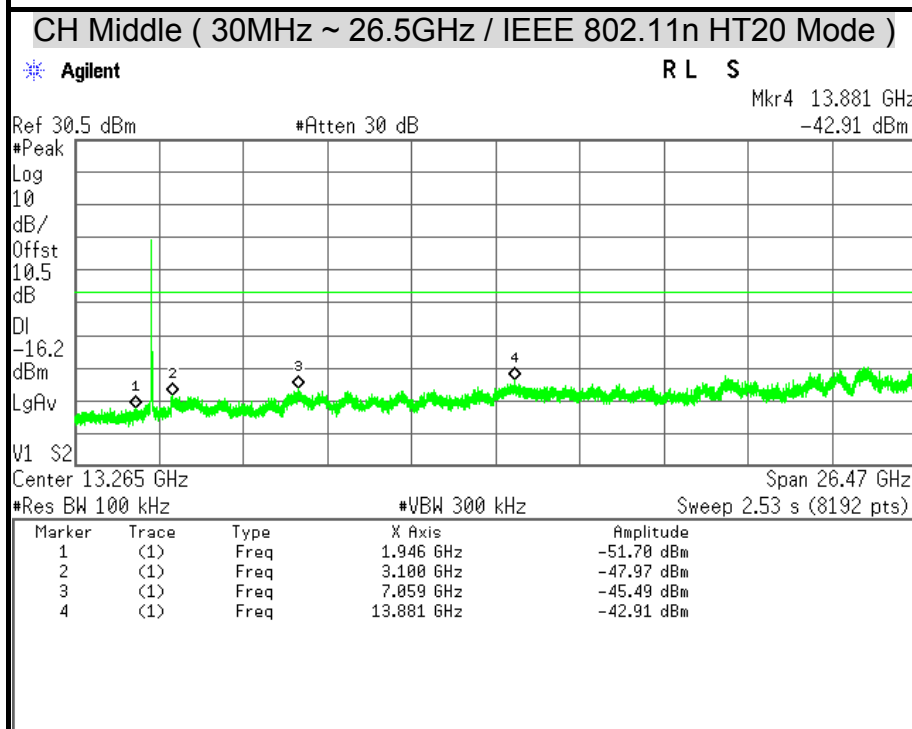
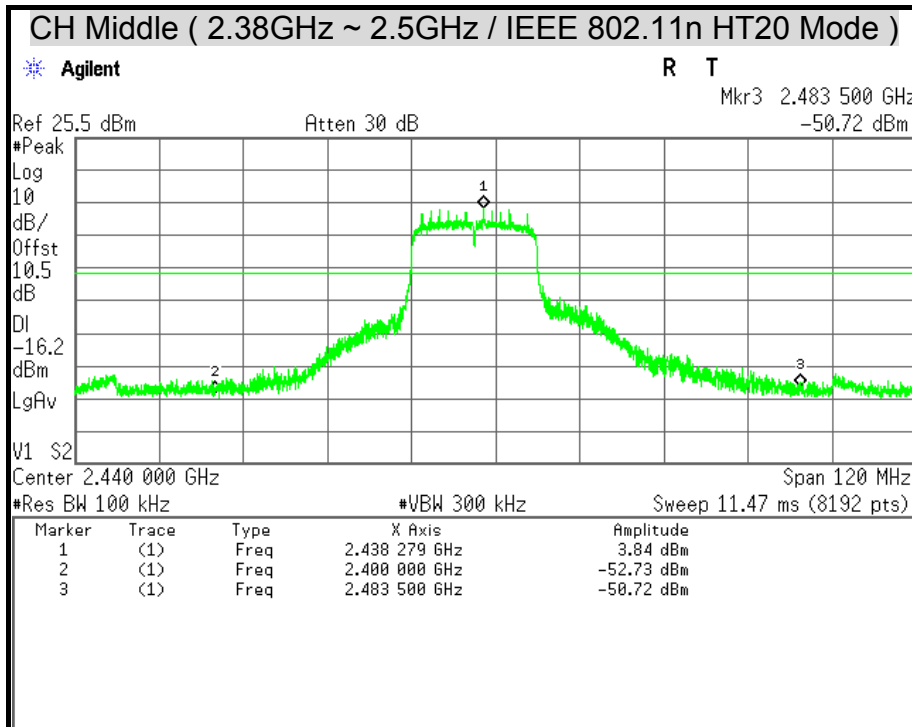



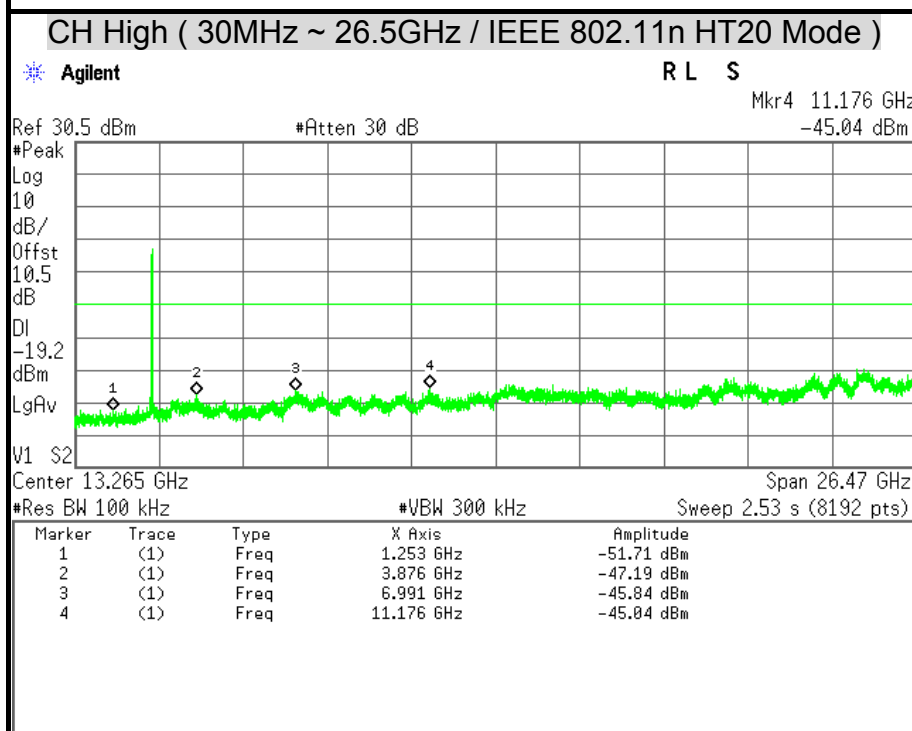
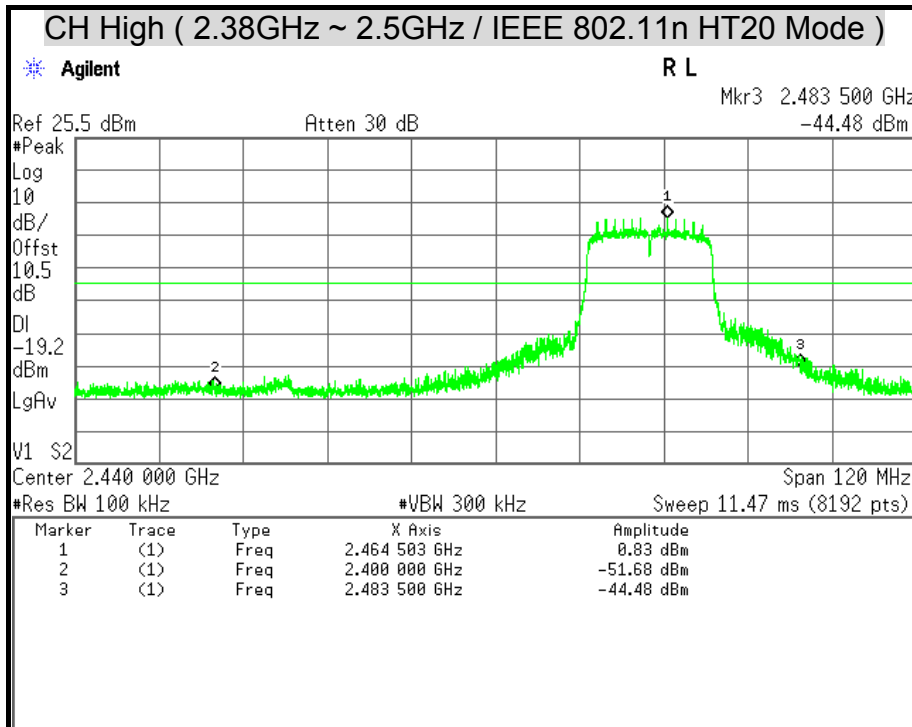



7.6 RADIATED EMISSION

LIMITS

(1) According to § 15.205 (a) Except as shown in paragraph (d) of this section, only spurious emissions are permitted in any of the frequency bands listed below:

MHz	MHz	MHz	GHz
0.090 - 0.110	16.42 - 16.423	399.9 - 410	4.5 - 5.15
<sup>1</sup> 0.495 - 0.505	16.69475 - 16.69525	608 - 614	5.35 - 5.46
2.1735 - 2.1905	16.80425 - 16.80475	960 - 1240	7.25 - 7.75
4.125 - 4.128	25.5 - 25.67	1300 - 1427	8.025 - 8.5
4.17725 - 4.17775	37.5 - 38.25	1435 - 1626.5	9.0 - 9.2
4.20725 - 4.20775	73 - 74.6	1645.5 - 1646.5	9.3 - 9.5
6.215 - 6.218	74.8 - 75.2	1660 - 1710	10.6 - 12.7
6.26775 - 6.26825	108 - 121.94	1718.8 - 1722.2	13.25 - 13.4
6.31175 - 6.31225	123 - 138	2200 - 2300	14.47 - 14.5
8.291 - 8.294	149.9 - 150.05	2310 - 2390	15.35 - 16.2
8.362 - 8.366	156.52475 - 156.52525	2483.5 - 2500	17.7 - 21.4
8.37625 - 8.38675	156.7 - 156.9	2655 - 2900	22.01 - 23.12
8.41425 - 8.41475	162.0125 - 167.17	3260 - 3267	23.6 - 24.0
12.29 - 12.293	167.72 - 173.2	3332 - 3339	31.2 - 31.8
12.51975 - 12.52025	240 - 285	3345.8 - 3338	36.43 - 36.5
12.57675 - 12.57725	322 - 335.4	3600 - 4400	( <sup>2</sup> )
13.36 - 13.41			

Remark:

- 1. <sup>1</sup> Until February 1, 1999, this restricted band shall be 0.490-0.510 MHz.
- 2. <sup>2</sup> Above 38.6

(2) According to § 15.205 (b) Except as provided in paragraphs (d) and (e), the field strength of emissions appearing within these frequency bands shall not exceed the limits shown in Section 15.209. At frequencies equal to or less than 1000 MHz, compliance with the limits in Section 15.209 shall be demonstrated using measurement instrumentation employing a CISPR quasi-peak detector. Above 1000 MHz, compliance with the emission limits in Section 15.209 shall be demonstrated based on the average value of the measured emissions. The provisions in Section 15.35 apply to these measurements.



(3) According to § 15.209 (a) Except as provided elsewhere in this Subpart, the emissions from an intentional radiator shall not exceed the field strength levels specified in the following table :

Frequency (MHz)	Field Strength (microvolts/meter)	Measurement Distance (meters)
0.009 – 0.490	2400/F(KHz)	300
0.490 – 1.705	24000/F(KHz)	30
1.705 – 30.0	30	30
30 - 88	100 **	3
88 - 216	150 **	3
216 - 960	200 **	3
Above 960	500	3

**Remark:** \*\*Except as provided in paragraph (g), fundamental emissions from intentional radiators operating under this Section shall not be located in the frequency bands 54-72 MHz, 76-88 MHz, 174-216 MHz or 470-806 MHz. However, operation within these frequency bands is permitted under other sections of this Part, e.g., Sections 15.231 and 15.241.

(4) According to § 15.209 (b) In the emission table above, the tighter limit applies at the band edges.

**TEST EQUIPMENT**

**Radiated Emission / 966Chamber\_B**

Name of Equipment	Manufacturer	Model	Serial Number	Calibration Due
Spectrum Analyzer	Agilent	E4446A	MY46180323	04/15/2015
EMI Test Receiver	ROHDE & SCHWARZ	ESCS 30	835418/008	10/16/2014
Broad-Band Horn Antenna	SCHWARZBECK	BBHA 9120 D	9120D-778	09/12/2014
Bi-log Antenna	SCHWARZBECK	VULB 9168	9168-250	09/12/2014
Double-Ridged Waveguide Horn	ETS-LINDGREN	3117	00078733	12/05/2014
Horn Antenna	COM-POWER	AH-840	03077	12/18/2014
Pre-Amplifier	Agilent	8447D	2944A10052	07/16/2014
Pre-Amplifier	Agilent	8449B	3008A01916	07/16/2014
LOOP Antenna	EMCO	6502	8905-2356	08/20/2014
Notch Filters Band Reject	Micro-Tronics	BRM05702-01	026	N.C.R

**Remark:** 1. Each piece of equipment is scheduled for calibration once a year.  
2. N.C.R = No Calibration Request.



**TEST SETUP**

The diagram below shows the test setup that is utilized to make the measurements for emission below 1GHz.

**9kHz ~ 30MHz**

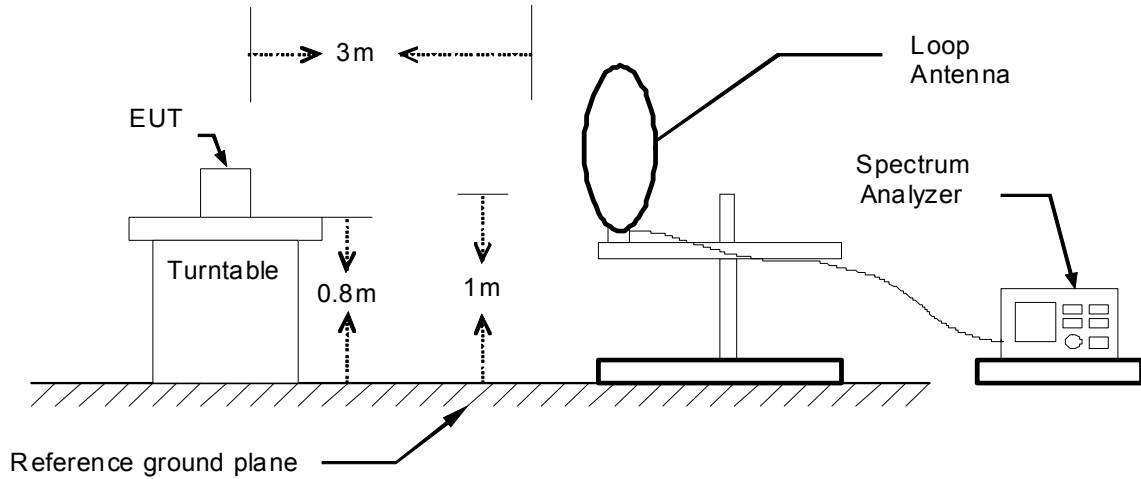

**30MHz ~ 1GHz**

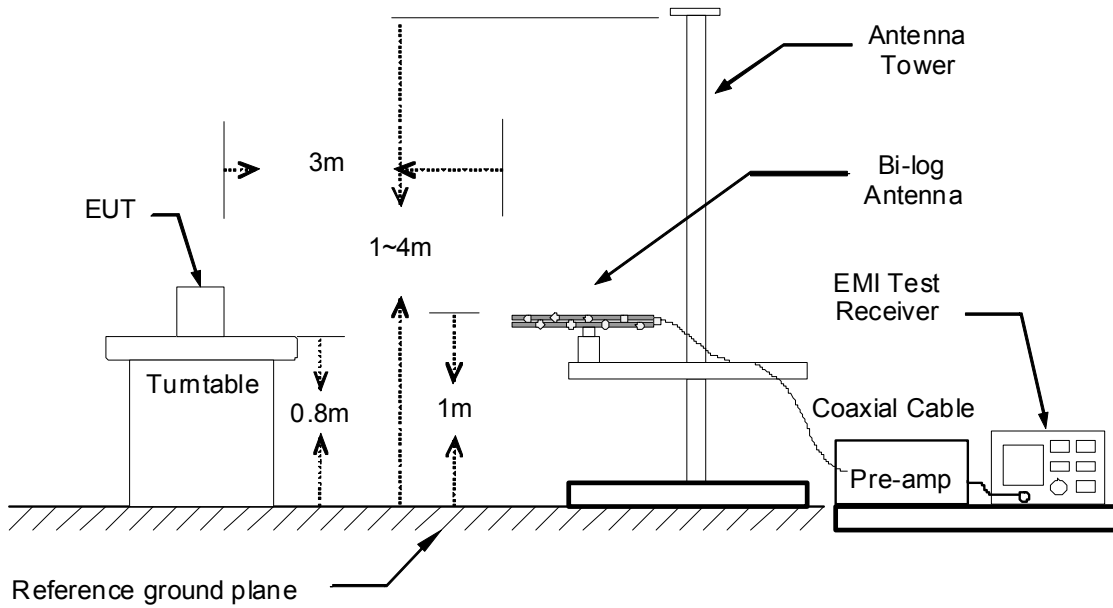



The diagram below shows the test setup that is utilized to make the measurements for emission above 1GHz.

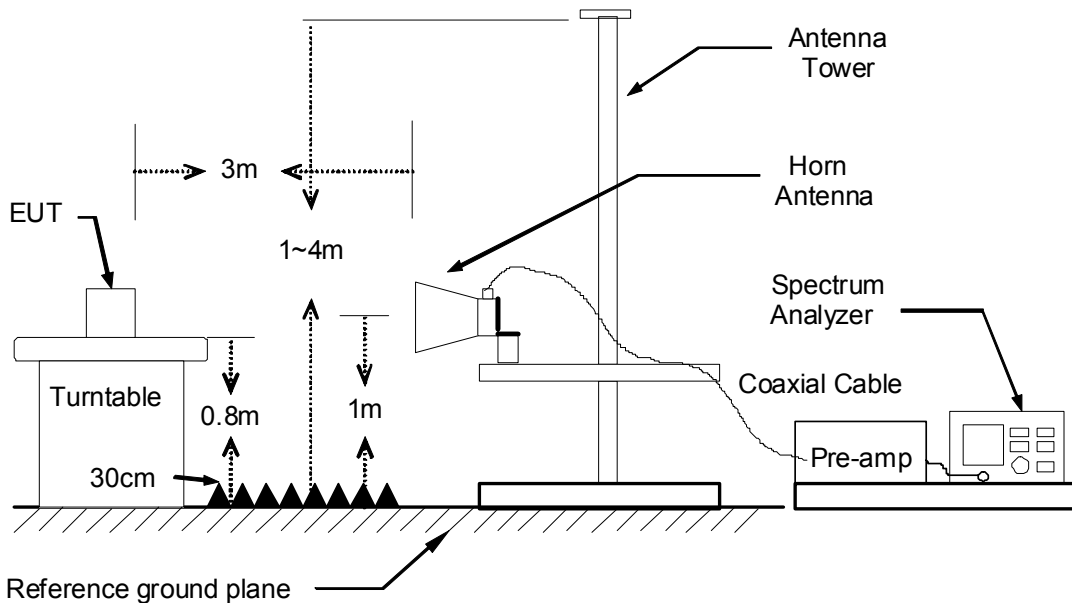

### **TEST PROCEDURE**

1. The EUT was placed on the top of a rotating table 0.8 meters above the ground. The table was rotated 360 degrees to determine the position of the highest radiation.
2. While measuring the radiated emission below 1GHz, the EUT was set 3 meters away from the interference-receiving antenna, which was mounted on the top of a variable-height antenna tower. While measuring the radiated emission above 1GHz, the EUT was set 3 meters away from the interference-receiving antenna.
3. The antenna is a broadband antenna, and its height is varied from one meter to four meters above the ground to determine the maximum value of the field strength. Both horizontal and vertical polarization of the antenna are set to make the measurement.
4. For each suspected emission, the EUT was arranged to its worst case and then the antenna was tuned to heights from 1 meter to 4 meters and the table was turned from 0 degrees to 360 degrees to find the maximum reading.
5. The test-receiver system was set to Peak Detect Function and Specified Bandwidth with Maximum Hold Mode.
6. If the emission level of the EUT in peak mode was 10 dB lower than the limit specified, then testing could be stopped and the peak values of the EUT would be reported. Otherwise the emissions that did not have 10 dB margin would be re-tested one by one using peak, quasi-peak or average method as specified and then reported in a data sheet.

#### **Remark :**

1. The resolution bandwidth and video bandwidth of test receiver/spectrum analyzer is 120 KHz for Peak detection (PK) and Quasi-peak detection (QP) at frequency below 1GHz.
2. The resolution bandwidth and video bandwidth of test receiver/spectrum analyzer is 1 MHz for Peak detection and frequency above 1GHz.
3. The resolution bandwidth of test receiver/spectrum analyzer is 1 MHz and the video bandwidth is 10 Hz for Average detection (AV) at frequency above 1GHz.



**TEST RESULTS**

**Below 1 GHz (9kHz ~ 30MHz)**

No emission found between lowest internal used/generated frequency to 30MHz.

**Below 1 GHz (30MHz ~ 1GHz)**

<b>Product Name</b>	WiFi Baby Cam	<b>Test By</b>	Rex Chiu
<b>Test Model</b>	TV-IP743SIC	<b>Test Date</b>	2014/05/06
<b>Test Mode</b>	Normal Operating (Full Function)	<b>Temp. &amp; Humidity</b>	20°C, 60%

966 Chamber_B at 3Meter / Horizontal						
Frequency (MHz)	Reading (dBµV)	Correction Factor (dB/m)	Result (dBµV/m)	Limit (dBµV/m)	Margin (dB)	Remark
37.76	40.03	-14.73	25.30	40.00	-14.70	Peak
154.16	36.37	-13.55	22.82	43.50	-20.68	Peak
191.99	38.24	-15.50	22.74	43.50	-20.76	Peak
399.57	42.38	-9.94	32.44	46.00	-13.56	Peak
800.18	43.49	-3.09	40.40	46.00	-5.60	Peak
960.23	31.46	-0.40	31.06	54.00	-22.94	Peak

966 Chamber_B at 3Meter / Vertical						
Frequency (MHz)	Reading (dBµV)	Correction Factor (dB/m)	Result (dBµV/m)	Limit (dBµV/m)	Margin (dB)	Remark
38.73	49.00	-14.61	34.39	40.00	-5.61	QP
117.30	46.01	-16.45	29.56	43.50	-13.94	Peak
399.57	42.13	-9.94	32.19	46.00	-13.81	Peak
610.06	41.23	-5.86	35.37	46.00	-10.63	Peak
700.27	39.96	-4.73	35.23	46.00	-10.77	Peak
800.18	45.53	-3.09	42.44	46.00	-3.56	Peak

**Remark:**

1. Quasi-peak test would be performed if the peak result were greater than the quasi-peak limit.
2. Data of measurement within this frequency range shown " --- " in the table above means the reading of emissions are attenuated more than 20dB below the permissible limits or the field strength is too small to be measured.
3. Correction Factor (dB/m) = Antenna Factor (dB/m) + Cable Loss (dB) – PreAmp.Gain (dB)
4. Result (dBuV/m) = Reading (dBuV) + Correction Factor (dB/m)
5. Margin (dB) = Remark result (dBuV/m) - Quasi-peak limit (dBuV/m).



Above 1 GHz

<b>Product Name</b>	WiFi Baby Cam	<b>Test By</b>	Waternil Guan
<b>Test Model</b>	TV-IP743SIC	<b>Test Date</b>	2014/04/24
<b>Test Mode</b>	IEEE 802.11b TX / CH Low	<b>Temp. &amp; Humidity</b>	26°C, 57%

966 Chamber_B at 3Meter / Horizontal									
Frequency (MHz)	Reading-PK (dBuV)	Reading-AV (dBuV)	Correction Factor (dB/m)	Result-PK (dBuV/m)	Result-AV (dBuV/m)	Limit-PK (dBuV/m)	Limit-AV (dBuV/m)	Margin (dB)	Remark
1190.00	51.06	---	-2.89	48.17	---	74.00	54.00	-5.83	Peak
1600.00	54.57	---	-1.96	52.61	---	74.00	54.00	-1.39	Peak
1870.00	49.63	---	0.59	50.22	---	74.00	54.00	-3.78	Peak
3195.00	45.08	---	4.24	49.32	---	74.00	54.00	-4.68	Peak
3735.00	40.83	---	5.13	45.97	---	74.00	54.00	-8.03	Peak
4830.00	42.84	---	8.09	50.93	---	74.00	54.00	-3.07	Peak

966 Chamber_B at 3Meter / Vertical									
Frequency (MHz)	Reading-PK (dBuV)	Reading-AV (dBuV)	Correction Factor (dB/m)	Result-PK (dBuV/m)	Result-AV (dBuV/m)	Limit-PK (dBuV/m)	Limit-AV (dBuV/m)	Margin (dB)	Remark
1296.00	50.58	---	-2.89	47.69	---	74.00	54.00	-6.31	Peak
1600.00	51.52	---	-1.96	49.56	---	74.00	54.00	-4.44	Peak
2308.00	56.42	44.70	2.43	58.85	47.13	74.00	54.00	-6.87	AVG
3210.00	43.68	---	4.25	47.93	---	74.00	54.00	-6.07	Peak
3870.00	41.30	---	5.50	46.80	---	74.00	54.00	-7.20	Peak
4830.00	41.55	---	8.09	49.64	---	74.00	54.00	-4.36	Peak

Remark:

1. Measuring frequencies from 1 GHz to the 10th harmonic of highest fundamental frequency.
2. Average test would be performed if the peak result were greater than the average limit.
3. Data of measurement within this frequency range shown " --- " in the table above means the reading of emissions are attenuated more than 20dB below the permissible limits or the field strength is too small to be measured.
4. Measurements above show only up to 6 maximum emissions noted, or would be lesser, with " N/A " remark, if no specific emissions from the EUT are recorded (ie: margin>20dB from the applicable limit) and considered that's already beyond the background noise floor.
5. Result = Reading + Correction Factor  
Margin = Result - Limit  
Remark Peak = Result(PK) - Limit(AV)  
Remark AVG = Result(AV) - Limit(AV)



<b>Product Name</b>	WiFi Baby Cam	<b>Test By</b>	Waternil Guan
<b>Test Model</b>	TV-IP743SIC	<b>Test Date</b>	2014/04/24
<b>Test Mode</b>	IEEE 802.11b TX / CH Middle	<b>Temp. &amp; Humidity</b>	26°C, 57%

966 Chamber_B at 3Meter / Horizontal									
Frequency (MHz)	Reading-PK (dBuV)	Reading-AV (dBuV)	Correction Factor (dB/m)	Result-PK (dBuV/m)	Result-AV (dBuV/m)	Limit-PK (dBuV/m)	Limit-AV (dBuV/m)	Margin (dB)	Remark
1600.00	53.41	---	-1.96	51.45	---	74.00	54.00	-2.55	Peak
1624.00	51.71	---	-1.73	49.98	---	74.00	54.00	-4.02	Peak
2308.00	52.30	40.14	2.43	54.73	42.57	74.00	54.00	-11.43	AVG
3195.00	45.36	---	4.24	49.60	---	74.00	54.00	-4.40	Peak
4530.00	40.09	---	7.47	47.56	---	74.00	54.00	-6.44	Peak
4875.00	41.74	---	8.18	49.92	---	74.00	54.00	-4.08	Peak

966 Chamber_B at 3Meter / Vertical									
Frequency (MHz)	Reading-PK (dBuV)	Reading-AV (dBuV)	Correction Factor (dB/m)	Result-PK (dBuV/m)	Result-AV (dBuV/m)	Limit-PK (dBuV/m)	Limit-AV (dBuV/m)	Margin (dB)	Remark
1600.00	51.23	---	-1.96	49.28	---	74.00	54.00	-4.72	Peak
1762.00	49.72	---	-0.43	49.29	---	74.00	54.00	-4.71	Peak
2290.00	58.42	46.37	2.39	60.81	48.76	74.00	54.00	-5.24	AVG
3150.00	43.16	---	4.20	47.36	---	74.00	54.00	-6.64	Peak
4545.00	40.09	---	7.50	47.59	---	74.00	54.00	-6.41	Peak
4875.00	40.36	---	8.18	48.54	---	74.00	54.00	-5.46	Peak

**Remark:**

1. Measuring frequencies from 1 GHz to the 10th harmonic of highest fundamental frequency.
2. Average test would be performed if the peak result were greater than the average limit.
3. Data of measurement within this frequency range shown " --- " in the table above means the reading of emissions are attenuated more than 20dB below the permissible limits or the field strength is too small to be measured.
4. Measurements above show only up to 6 maximum emissions noted, or would be lesser, with " N/A " remark, if no specific emissions from the EUT are recorded (ie: margin>20dB from the applicable limit) and considered that's already beyond the background noise floor.
5. Result = Reading + Correction Factor  
Margin = Result - Limit  
Remark Peak = Result(PK) - Limit(AV)  
Remark AVG = Result(AV) - Limit(AV)





<b>Product Name</b>	WiFi Baby Cam	<b>Test By</b>	Waternil Guan
<b>Test Model</b>	TV-IP743SIC	<b>Test Date</b>	2014/04/24
<b>Test Mode</b>	IEEE 802.11b TX / CH High	<b>Temp. &amp; Humidity</b>	26°C, 57%

**966 Chamber\_B at 3Meter / Horizontal**

Frequency (MHz)	Reading-PK (dBuV)	Reading-AV (dBuV)	Correction Factor (dB/m)	Result-PK (dBuV/m)	Result-AV (dBuV/m)	Limit-PK (dBuV/m)	Limit-AV (dBuV/m)	Margin (dB)	Remark
1600.00	53.06	---	-1.96	51.11	---	74.00	54.00	-2.89	Peak
1642.00	53.93	---	-1.56	52.37	---	74.00	54.00	-1.63	Peak
2320.00	54.57	43.18	2.45	57.02	45.63	74.00	54.00	-8.37	AVG
3195.00	44.66	---	4.24	48.90	---	74.00	54.00	-5.10	Peak
3780.00	41.70	---	5.26	46.96	---	74.00	54.00	-7.04	Peak
4920.00	41.62	---	8.28	49.89	---	74.00	54.00	-4.11	Peak

**966 Chamber\_B at 3Meter / Vertical**

Frequency (MHz)	Reading-PK (dBuV)	Reading-AV (dBuV)	Correction Factor (dB/m)	Result-PK (dBuV/m)	Result-AV (dBuV/m)	Limit-PK (dBuV/m)	Limit-AV (dBuV/m)	Margin (dB)	Remark
1600.00	51.11	---	-1.96	49.15	---	74.00	54.00	-4.85	Peak
1642.00	51.52	---	-1.56	49.96	---	74.00	54.00	-4.04	Peak
2348.00	57.51	46.66	2.51	60.02	49.17	74.00	54.00	-4.83	AVG
3225.00	42.15	---	4.26	46.42	---	74.00	54.00	-7.58	Peak
4920.00	40.26	---	8.28	48.53	---	74.00	54.00	-5.47	Peak
4980.00	40.79	---	8.40	49.19	---	74.00	54.00	-4.81	Peak

**Remark:**

1. Measuring frequencies from 1 GHz to the 10th harmonic of highest fundamental frequency.
2. Average test would be performed if the peak result were greater than the average limit.
3. Data of measurement within this frequency range shown " --- " in the table above means the reading of emissions are attenuated more than 20dB below the permissible limits or the field strength is too small to be measured.
4. Measurements above show only up to 6 maximum emissions noted, or would be lesser, with " N/A " remark, if no specific emissions from the EUT are recorded (ie: margin>20dB from the applicable limit) and considered that's already beyond the background noise floor.
5. Result = Reading + Correction Factor  
Margin = Result - Limit  
Remark Peak = Result(PK) - Limit(AV)  
Remark AVG = Result(AV) - Limit(AV)



<b>Product Name</b>	WiFi Baby Cam	<b>Test By</b>	Waternil Guan
<b>Test Model</b>	TV-IP743SIC	<b>Test Date</b>	2014/04/24
<b>Test Mode</b>	IEEE 802.11g TX / CH Low	<b>Temp. &amp; Humidity</b>	26°C, 57%

966 Chamber_B at 3Meter / Horizontal									
Frequency (MHz)	Reading-PK (dBuV)	Reading-AV (dBuV)	Correction Factor (dB/m)	Result-PK (dBuV/m)	Result-AV (dBuV/m)	Limit-PK (dBuV/m)	Limit-AV (dBuV/m)	Margin (dB)	Remark
1058.00	51.25	---	-2.88	48.37	---	74.00	54.00	-5.63	Peak
1320.00	50.51	---	-2.89	47.62	---	74.00	54.00	-6.38	Peak
1600.00	52.75	---	-1.96	50.80	---	74.00	54.00	-3.20	Peak
3195.00	45.28	---	4.24	49.52	---	74.00	54.00	-4.48	Peak
4560.00	40.03	---	7.53	47.56	---	74.00	54.00	-6.44	Peak
4845.00	39.78	---	8.12	47.90	---	74.00	54.00	-6.10	Peak

966 Chamber_B at 3Meter / Vertical									
Frequency (MHz)	Reading-PK (dBuV)	Reading-AV (dBuV)	Correction Factor (dB/m)	Result-PK (dBuV/m)	Result-AV (dBuV/m)	Limit-PK (dBuV/m)	Limit-AV (dBuV/m)	Margin (dB)	Remark
1346.00	50.04	---	-2.89	47.15	---	74.00	54.00	-6.85	Peak
1600.00	50.78	---	-1.96	48.83	---	74.00	54.00	-5.17	Peak
2288.00	53.31	40.87	2.39	55.70	43.26	74.00	54.00	-10.74	AVG
3210.00	43.94	---	4.25	48.19	---	74.00	54.00	-5.81	Peak
4560.00	39.76	---	7.53	47.29	---	74.00	54.00	-6.71	Peak
4935.00	40.89	---	8.31	49.19	---	74.00	54.00	-4.81	Peak

**Remark:**

1. Measuring frequencies from 1 GHz to the 10th harmonic of highest fundamental frequency.
2. Average test would be performed if the peak result were greater than the average limit.
3. Data of measurement within this frequency range shown " --- " in the table above means the reading of emissions are attenuated more than 20dB below the permissible limits or the field strength is too small to be measured.
4. Measurements above show only up to 6 maximum emissions noted, or would be lesser, with " N/A " remark, if no specific emissions from the EUT are recorded (ie: margin>20dB from the applicable limit) and considered that's already beyond the background noise floor.
5. Result = Reading + Correction Factor  
Margin = Result - Limit  
Remark Peak = Result(PK) - Limit(AV)  
Remark AVG = Result(AV) - Limit(AV)



<b>Product Name</b>	WiFi Baby Cam	<b>Test By</b>	Waternil Guan
<b>Test Model</b>	TV-IP743SIC	<b>Test Date</b>	2014/04/24
<b>Test Mode</b>	IEEE 802.11g TX / CH Middle	<b>Temp. &amp; Humidity</b>	26°C, 57%

966 Chamber_B at 3Meter / Horizontal									
Frequency (MHz)	Reading-PK (dBuV)	Reading-AV (dBuV)	Correction Factor (dB/m)	Result-PK (dBuV/m)	Result-AV (dBuV/m)	Limit-PK (dBuV/m)	Limit-AV (dBuV/m)	Margin (dB)	Remark
1082.00	50.51	---	-2.88	47.63	---	74.00	54.00	-6.37	Peak
1186.00	50.01	---	-2.89	47.12	---	74.00	54.00	-6.88	Peak
1600.00	53.09	---	-1.96	51.13	---	74.00	54.00	-2.87	Peak
3195.00	44.19	---	4.24	48.43	---	74.00	54.00	-5.57	Peak
4560.00	40.46	---	7.53	48.00	---	74.00	54.00	-6.00	Peak
4875.00	39.14	---	8.18	47.33	---	74.00	54.00	-6.67	Peak

966 Chamber_B at 3Meter / Vertical									
Frequency (MHz)	Reading-PK (dBuV)	Reading-AV (dBuV)	Correction Factor (dB/m)	Result-PK (dBuV/m)	Result-AV (dBuV/m)	Limit-PK (dBuV/m)	Limit-AV (dBuV/m)	Margin (dB)	Remark
1194.00	49.52	---	-2.89	46.63	---	74.00	54.00	-7.37	Peak
1600.00	51.39	---	-1.96	49.43	---	74.00	54.00	-4.57	Peak
2384.00	57.92	47.71	2.58	60.50	50.29	74.00	54.00	-3.71	AVG
3255.00	42.62	---	4.29	46.91	---	74.00	54.00	-7.09	Peak
4620.00	40.30	---	7.66	47.96	---	74.00	54.00	-6.04	Peak
4875.00	39.01	---	8.18	47.19	---	74.00	54.00	-6.81	Peak

**Remark:**

1. Measuring frequencies from 1 GHz to the 10th harmonic of highest fundamental frequency.
2. Average test would be performed if the peak result were greater than the average limit.
3. Data of measurement within this frequency range shown " --- " in the table above means the reading of emissions are attenuated more than 20dB below the permissible limits or the field strength is too small to be measured.
4. Measurements above show only up to 6 maximum emissions noted, or would be lesser, with " N/A " remark, if no specific emissions from the EUT are recorded (ie: margin>20dB from the applicable limit) and considered that's already beyond the background noise floor.
5. Result = Reading + Correction Factor  
Margin = Result - Limit  
Remark Peak = Result(PK) - Limit(AV)  
Remark AVG = Result(AV) - Limit(AV)



<b>Product Name</b>	WiFi Baby Cam	<b>Test By</b>	Waternil Guan
<b>Test Model</b>	TV-IP743SIC	<b>Test Date</b>	2014/04/24
<b>Test Mode</b>	IEEE 802.11g TX / CH High	<b>Temp. &amp; Humidity</b>	26°C, 57%

**966 Chamber\_B at 3Meter / Horizontal**

Frequency (MHz)	Reading-PK (dBuV)	Reading-AV (dBuV)	Correction Factor (dB/m)	Result-PK (dBuV/m)	Result-AV (dBuV/m)	Limit-PK (dBuV/m)	Limit-AV (dBuV/m)	Margin (dB)	Remark
1012.00	51.16	---	-2.88	48.28	---	74.00	54.00	-5.72	Peak
1170.00	50.58	---	-2.89	47.69	---	74.00	54.00	-6.31	Peak
2016.00	48.96	---	1.85	50.81	---	74.00	54.00	-3.19	Peak
3195.00	44.43	---	4.24	48.67	---	74.00	54.00	-5.33	Peak
4335.00	40.27	---	6.90	47.16	---	74.00	54.00	-6.84	Peak
4920.00	39.44	---	8.28	47.71	---	74.00	54.00	-6.29	Peak

**966 Chamber\_B at 3Meter / Vertical**

Frequency (MHz)	Reading-PK (dBuV)	Reading-AV (dBuV)	Correction Factor (dB/m)	Result-PK (dBuV/m)	Result-AV (dBuV/m)	Limit-PK (dBuV/m)	Limit-AV (dBuV/m)	Margin (dB)	Remark
1236.00	50.45	---	-2.89	47.56	---	74.00	54.00	-6.44	Peak
1600.00	51.28	---	-1.96	49.32	---	74.00	54.00	-4.68	Peak
2342.00	52.84	42.91	2.50	55.34	45.41	74.00	54.00	-8.59	AVG
3345.00	43.20	---	4.36	47.56	---	74.00	54.00	-6.44	Peak
4920.00	39.12	---	8.28	47.39	---	74.00	54.00	-6.61	Peak
5040.00	40.55	---	8.51	49.06	---	74.00	54.00	-4.94	Peak

**Remark:**

1. Measuring frequencies from 1 GHz to the 10th harmonic of highest fundamental frequency.
2. Average test would be performed if the peak result were greater than the average limit.
3. Data of measurement within this frequency range shown " --- " in the table above means the reading of emissions are attenuated more than 20dB below the permissible limits or the field strength is too small to be measured.
4. Measurements above show only up to 6 maximum emissions noted, or would be lesser, with " N/A " remark, if no specific emissions from the EUT are recorded (ie: margin>20dB from the applicable limit) and considered that's already beyond the background noise floor.
5. Result = Reading + Correction Factor  
Margin = Result - Limit  
Remark Peak = Result(PK) - Limit(AV)  
Remark AVG = Result(AV) - Limit(AV)



<b>Product Name</b>	WiFi Baby Cam	<b>Test By</b>	Waternil Guan
<b>Test Model</b>	TV-IP743SIC	<b>Test Date</b>	2014/04/24
<b>Test Mode</b>	IEEE 802.11n HT20 TX / CH Low	<b>Temp. &amp; Humidity</b>	26°C, 57%

**966 Chamber\_B at 3Meter / Horizontal**

Frequency (MHz)	Reading-PK (dBuV)	Reading-AV (dBuV)	Correction Factor (dB/m)	Result-PK (dBuV/m)	Result-AV (dBuV/m)	Limit-PK (dBuV/m)	Limit-AV (dBuV/m)	Margin (dB)	Remark
1128.00	50.82	---	-2.89	47.94	---	74.00	54.00	-6.06	Peak
1600.00	53.17	---	-1.96	51.21	---	74.00	54.00	-2.79	Peak
2298.00	49.14	---	2.41	51.55	---	74.00	54.00	-2.45	Peak
3210.00	44.77	---	4.25	49.02	---	74.00	54.00	-4.98	Peak
4305.00	40.53	---	6.81	47.34	---	74.00	54.00	-6.66	Peak
4815.00	39.23	---	8.06	47.29	---	74.00	54.00	-6.71	Peak

**966 Chamber\_B at 3Meter / Vertical**

Frequency (MHz)	Reading-PK (dBuV)	Reading-AV (dBuV)	Correction Factor (dB/m)	Result-PK (dBuV/m)	Result-AV (dBuV/m)	Limit-PK (dBuV/m)	Limit-AV (dBuV/m)	Margin (dB)	Remark
1218.00	49.99	---	-2.89	47.10	---	74.00	54.00	-6.90	Peak
1600.00	50.94	---	-1.96	48.98	---	74.00	54.00	-5.02	Peak
1914.00	48.65	---	1.01	49.66	---	74.00	54.00	-4.34	Peak
3210.00	43.45	---	4.25	47.70	---	74.00	54.00	-6.30	Peak
3870.00	41.44	---	5.50	46.95	---	74.00	54.00	-7.05	Peak
4800.00	39.02	---	8.03	47.05	---	74.00	54.00	-6.95	Peak

**Remark:**

1. Measuring frequencies from 1 GHz to the 10th harmonic of highest fundamental frequency.
2. Average test would be performed if the peak result were greater than the average limit.
3. Data of measurement within this frequency range shown " --- " in the table above means the reading of emissions are attenuated more than 20dB below the permissible limits or the field strength is too small to be measured.
4. Measurements above show only up to 6 maximum emissions noted, or would be lesser, with " N/A " remark, if no specific emissions from the EUT are recorded (ie: margin>20dB from the applicable limit) and considered that's already beyond the background noise floor.
5. Result = Reading + Correction Factor  
Margin = Result - Limit  
Remark Peak = Result(PK) - Limit(AV)  
Remark AVG = Result(AV) - Limit(AV)



<b>Product Name</b>	WiFi Baby Cam	<b>Test By</b>	Waternil Guan
<b>Test Model</b>	TV-IP743SIC	<b>Test Date</b>	2014/04/24
<b>Test Mode</b>	IEEE 802.11n HT20 TX / CH Middle	<b>Temp. &amp; Humidity</b>	26°C, 57%

966 Chamber_B at 3Meter / Horizontal									
Frequency (MHz)	Reading-PK (dBuV)	Reading-AV (dBuV)	Correction Factor (dB/m)	Result-PK (dBuV/m)	Result-AV (dBuV/m)	Limit-PK (dBuV/m)	Limit-AV (dBuV/m)	Margin (dB)	Remark
1204.00	50.45	---	-2.89	47.56	---	74.00	54.00	-6.44	Peak
1600.00	53.40	---	-1.96	51.45	---	74.00	54.00	-2.55	Peak
2386.00	54.64	41.89	2.58	57.22	44.47	74.00	54.00	-9.53	AVG
3195.00	45.18	---	4.24	49.42	---	74.00	54.00	-4.58	Peak
4200.00	41.10	---	6.48	47.58	---	74.00	54.00	-6.42	Peak
4890.00	41.35	---	8.21	49.57	---	74.00	54.00	-4.43	Peak

966 Chamber_B at 3Meter / Vertical									
Frequency (MHz)	Reading-PK (dBuV)	Reading-AV (dBuV)	Correction Factor (dB/m)	Result-PK (dBuV/m)	Result-AV (dBuV/m)	Limit-PK (dBuV/m)	Limit-AV (dBuV/m)	Margin (dB)	Remark
1600.00	51.54	---	-1.96	49.59	---	74.00	54.00	-4.41	Peak
2384.00	57.31	47.51	2.58	59.89	50.09	74.00	54.00	-3.91	AVG
2484.00	60.30	45.68	2.78	63.08	48.46	74.00	54.00	-5.54	AVG
3255.00	44.02	---	4.29	48.31	---	74.00	54.00	-5.69	Peak
4260.00	40.87	---	6.67	47.54	---	74.00	54.00	-6.46	Peak
4875.00	38.65	---	8.18	46.83	---	74.00	54.00	-7.17	Peak

**Remark:**

1. Measuring frequencies from 1 GHz to the 10th harmonic of highest fundamental frequency.
2. Average test would be performed if the peak result were greater than the average limit.
3. Data of measurement within this frequency range shown " --- " in the table above means the reading of emissions are attenuated more than 20dB below the permissible limits or the field strength is too small to be measured.
4. Measurements above show only up to 6 maximum emissions noted, or would be lesser, with " N/A " remark, if no specific emissions from the EUT are recorded (ie: margin>20dB from the applicable limit) and considered that's already beyond the background noise floor.
5. Result = Reading + Correction Factor  
Margin = Result - Limit  
Remark Peak = Result(PK) - Limit(AV)  
Remark AVG = Result(AV) - Limit(AV)



<b>Product Name</b>	WiFi Baby Cam	<b>Test By</b>	Waternil Guan
<b>Test Model</b>	TV-IP743SIC	<b>Test Date</b>	2014/04/24
<b>Test Mode</b>	IEEE 802.11n HT20 TX / CH High	<b>Temp. &amp; Humidity</b>	26°C, 57%

966 Chamber_B at 3Meter / Horizontal									
Frequency (MHz)	Reading-PK (dBuV)	Reading-AV (dBuV)	Correction Factor (dB/m)	Result-PK (dBuV/m)	Result-AV (dBuV/m)	Limit-PK (dBuV/m)	Limit-AV (dBuV/m)	Margin (dB)	Remark
1474.00	50.02	---	-2.90	47.12	---	74.00	54.00	-6.88	Peak
1600.00	52.73	---	-1.96	50.77	---	74.00	54.00	-3.23	Peak
2380.00	49.03	---	2.57	51.60	---	74.00	54.00	-2.40	Peak
3195.00	45.20	---	4.24	49.44	---	74.00	54.00	-4.56	Peak
3900.00	41.36	---	5.59	46.95	---	74.00	54.00	-7.05	Peak
4935.00	39.93	---	8.31	48.24	---	74.00	54.00	-5.76	Peak

966 Chamber_B at 3Meter / Vertical									
Frequency (MHz)	Reading-PK (dBuV)	Reading-AV (dBuV)	Correction Factor (dB/m)	Result-PK (dBuV/m)	Result-AV (dBuV/m)	Limit-PK (dBuV/m)	Limit-AV (dBuV/m)	Margin (dB)	Remark
1600.00	51.33	---	-1.96	49.38	---	74.00	54.00	-4.62	Peak
2346.00	49.96	---	2.51	52.47	---	74.00	54.00	-1.53	Peak
2860.00	48.59	---	3.72	52.32	---	74.00	54.00	-1.68	Peak
3285.00	42.94	---	4.31	47.26	---	74.00	54.00	-6.74	Peak
4410.00	40.89	---	7.13	48.02	---	74.00	54.00	-5.98	Peak
4920.00	40.03	---	8.28	48.30	---	74.00	54.00	-5.70	Peak

**Remark:**

1. Measuring frequencies from 1 GHz to the 10th harmonic of highest fundamental frequency.
2. Average test would be performed if the peak result were greater than the average limit.
3. Data of measurement within this frequency range shown " --- " in the table above means the reading of emissions are attenuated more than 20dB below the permissible limits or the field strength is too small to be measured.
4. Measurements above show only up to 6 maximum emissions noted, or would be lesser, with " N/A " remark, if no specific emissions from the EUT are recorded (ie: margin>20dB from the applicable limit) and considered that's already beyond the background noise floor.
5. Result = Reading + Correction Factor  
Margin = Result - Limit  
Remark Peak = Result(PK) - Limit(AV)  
Remark AVG = Result(AV) - Limit(AV)



Restricted Band Edges

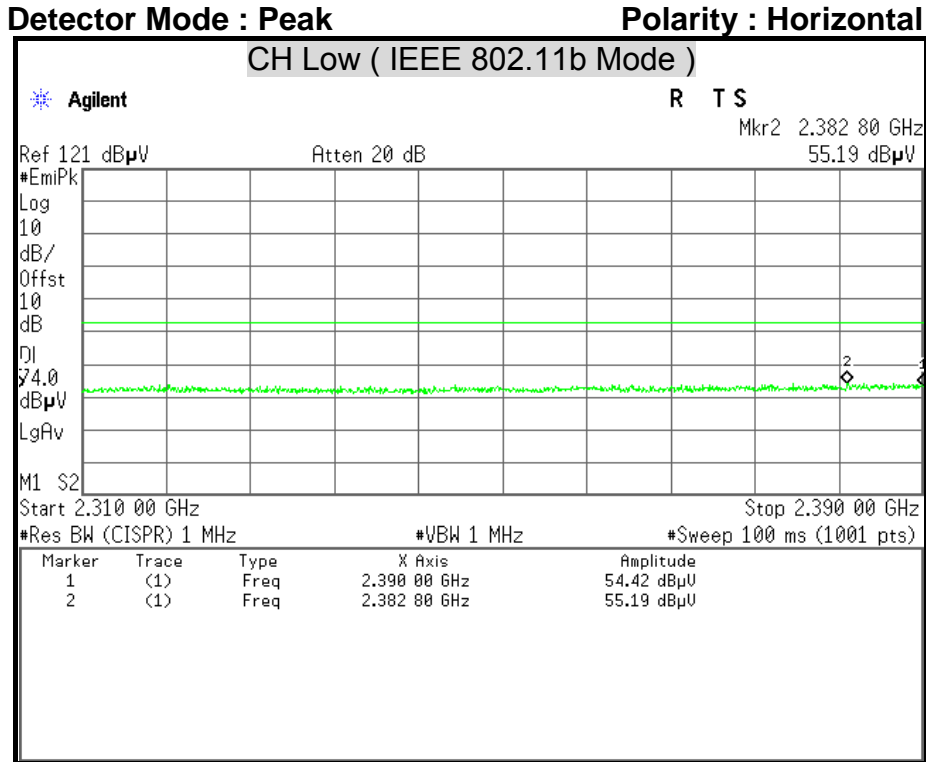

**Remark:** 1. Correction Factor (dB/m) = Antenna Factor (dB/m) + Cable Loss (dB) – PreAmp.Gain (dB)  
 2. The correction factor was entered as an offset in the spectrum analyzer to allow for direct reading of power.

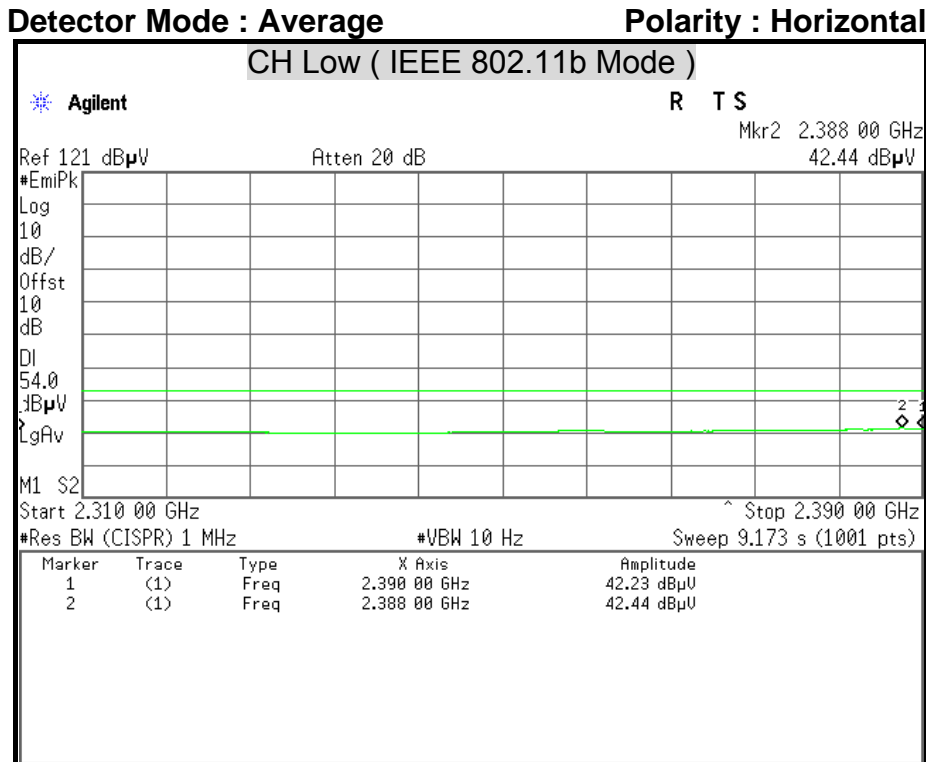

**Remark:** 1. Correction Factor (dB/m) = Antenna Factor (dB/m) + Cable Loss (dB) – PreAmp.Gain (dB)  
 2. The correction factor was entered as an offset in the spectrum analyzer to allow for direct reading of power.





Detector Mode : Peak

Polarity : Vertical

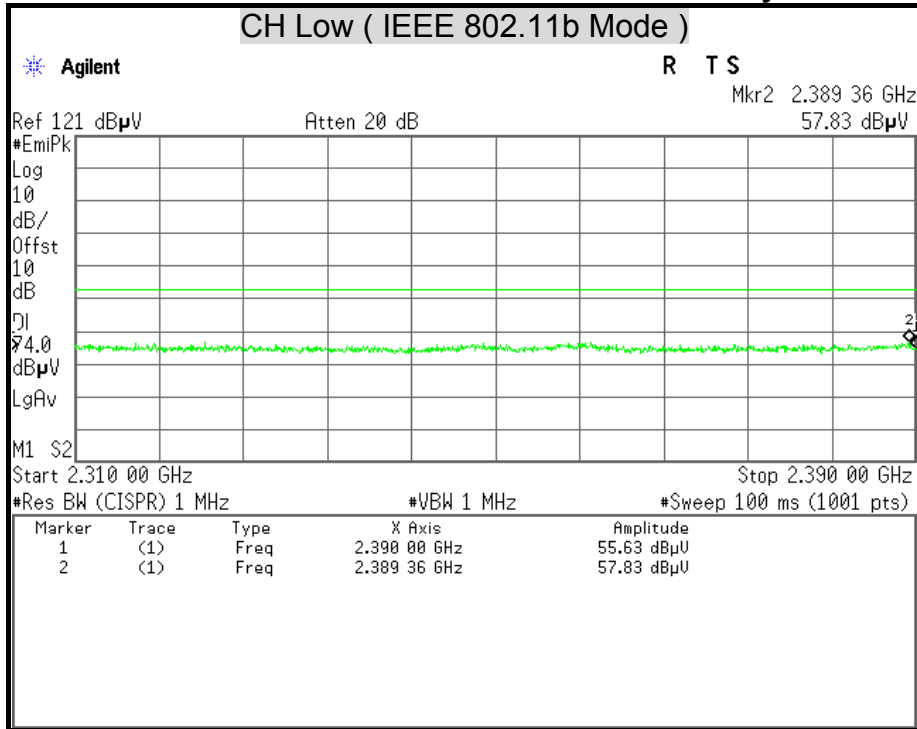

- Remark:**
1. Correction Factor (dB/m) = Antenna Factor (dB/m) + Cable Loss (dB) – PreAmp.Gain (dB)
  2. The correction factor was entered as an offset in the spectrum analyzer to allow for direct reading of power.

Detector Mode : Average

Polarity : Vertical

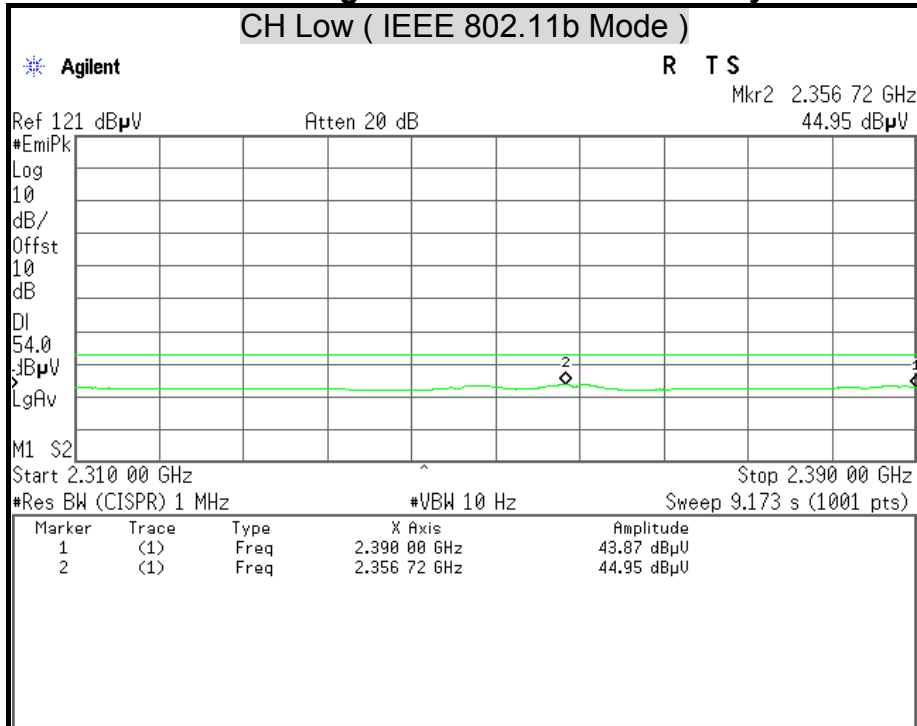

- Remark:**
1. Correction Factor (dB/m) = Antenna Factor (dB/m) + Cable Loss (dB) – PreAmp.Gain (dB)
  2. The correction factor was entered as an offset in the spectrum analyzer to allow for direct reading of power.



Detector Mode : Peak

Polarity : Horizontal

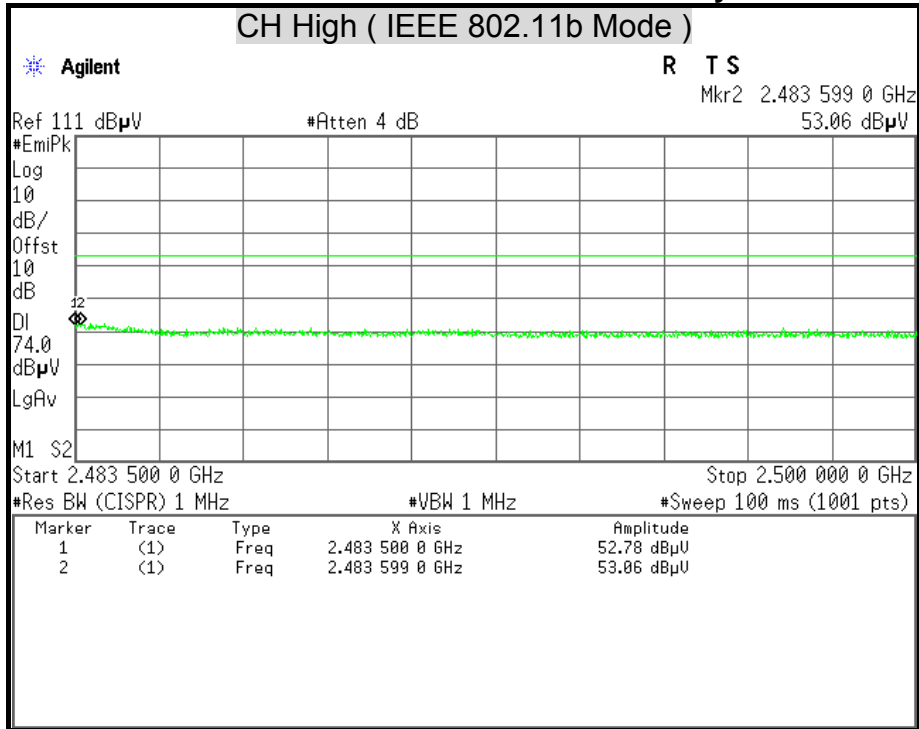

- Remark:** 1. Correction Factor (dB/m) = Antenna Factor (dB/m) + Cable Loss (dB) – PreAmp.Gain (dB)
2. The correction factor was entered as an offset in the spectrum analyzer to allow for direct reading of power.

Detector Mode : Average

Polarity : Horizontal

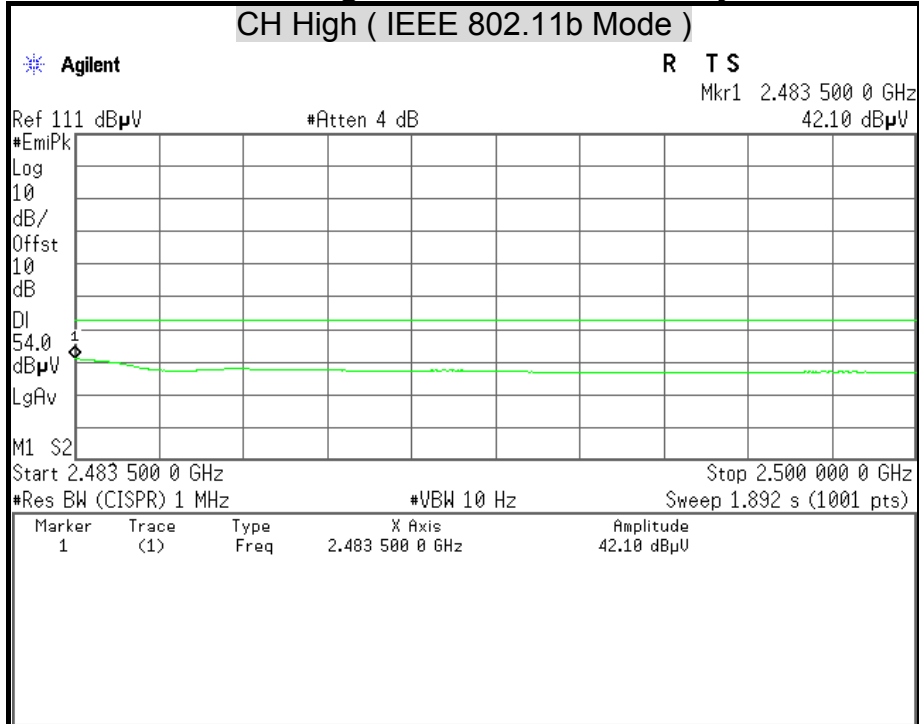

- Remark:** 1. Correction Factor (dB/m) = Antenna Factor (dB/m) + Cable Loss (dB) – PreAmp.Gain (dB)
2. The correction factor was entered as an offset in the spectrum analyzer to allow for direct reading of power.



Detector Mode : Peak

Polarity : Vertical

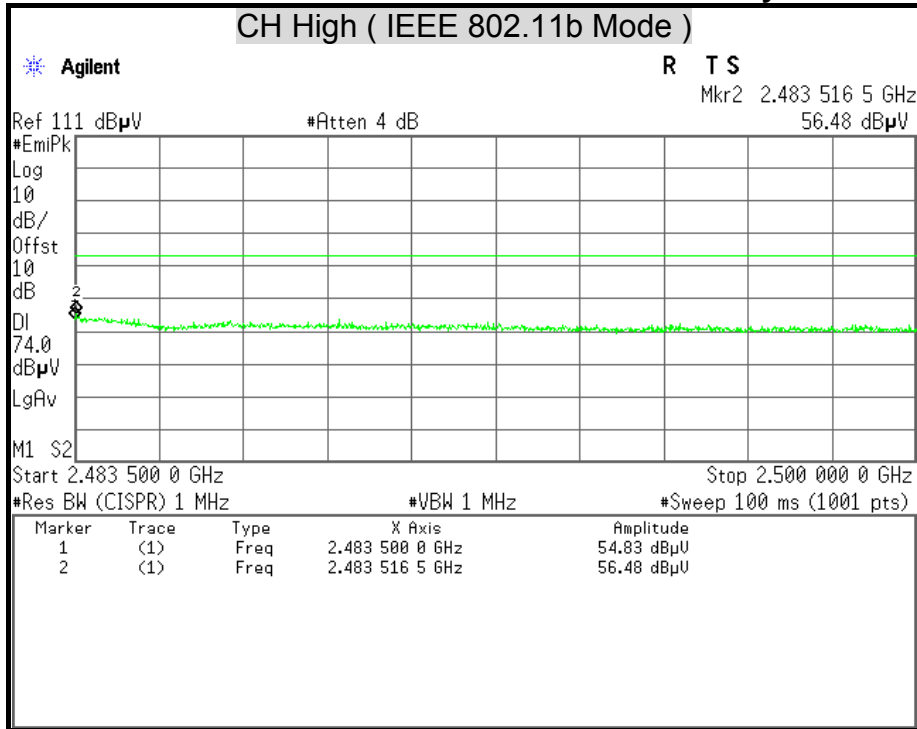

**Remark:** 1. Correction Factor (dB/m) = Antenna Factor (dB/m) + Cable Loss (dB) – PreAmp.Gain (dB)  
 2. The correction factor was entered as an offset in the spectrum analyzer to allow for direct reading of power.

Detector Mode : Average

Polarity : Vertical

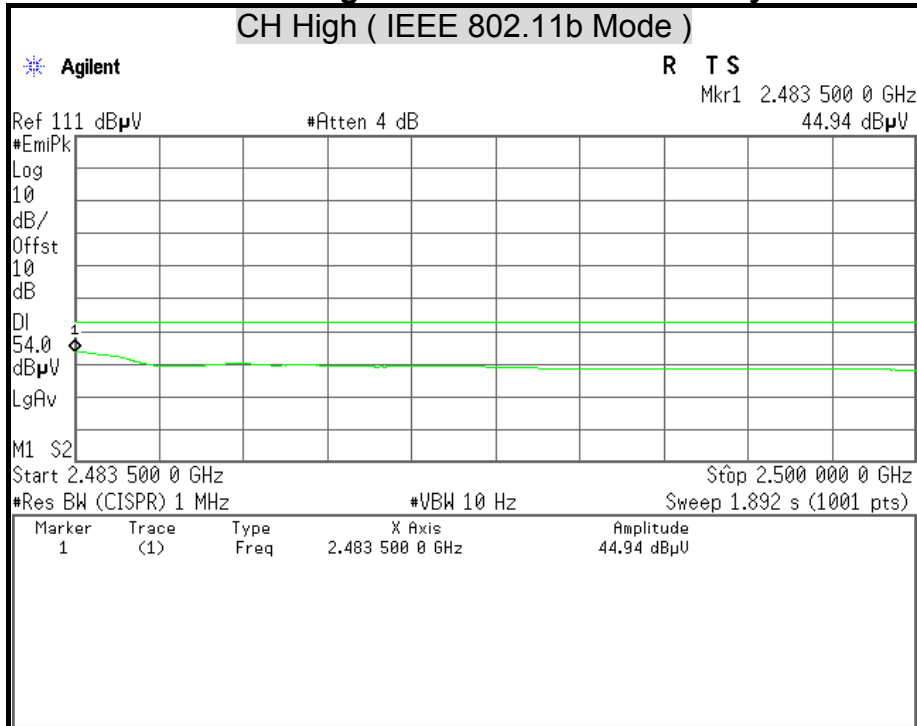

**Remark:** 1. Correction Factor (dB/m) = Antenna Factor (dB/m) + Cable Loss (dB) – PreAmp.Gain (dB)  
 2. The correction factor was entered as an offset in the spectrum analyzer to allow for direct reading of power.



Detector Mode : Peak Polarity : Horizontal

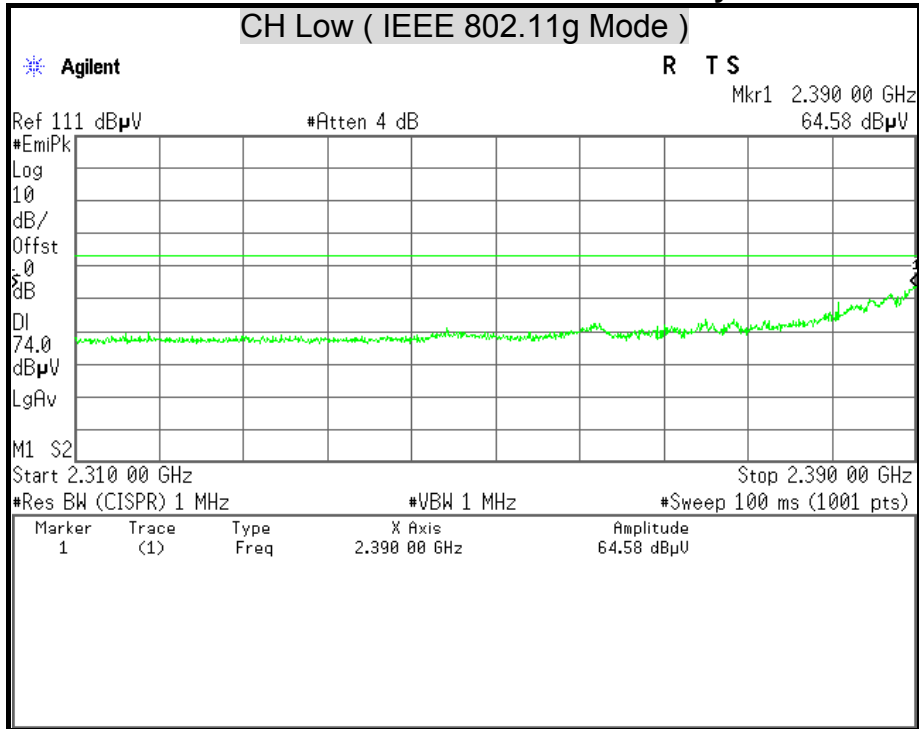

- Remark:** 1. Correction Factor (dB/m) = Antenna Factor (dB/m) + Cable Loss (dB) – PreAmp.Gain (dB)  
 2. The correction factor was entered as an offset in the spectrum analyzer to allow for direct reading of power.

Detector Mode : Average Polarity : Horizontal

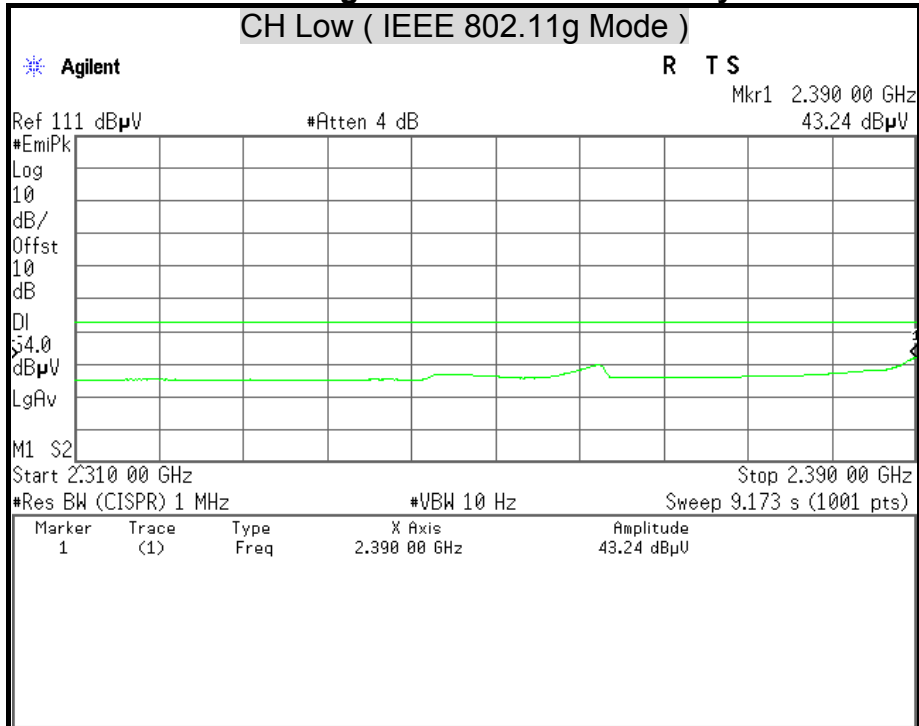

- Remark:** 1. Correction Factor (dB/m) = Antenna Factor (dB/m) + Cable Loss (dB) – PreAmp.Gain (dB)  
 2. The correction factor was entered as an offset in the spectrum analyzer to allow for direct reading of power.



Detector Mode : Peak

Polarity : Vertical

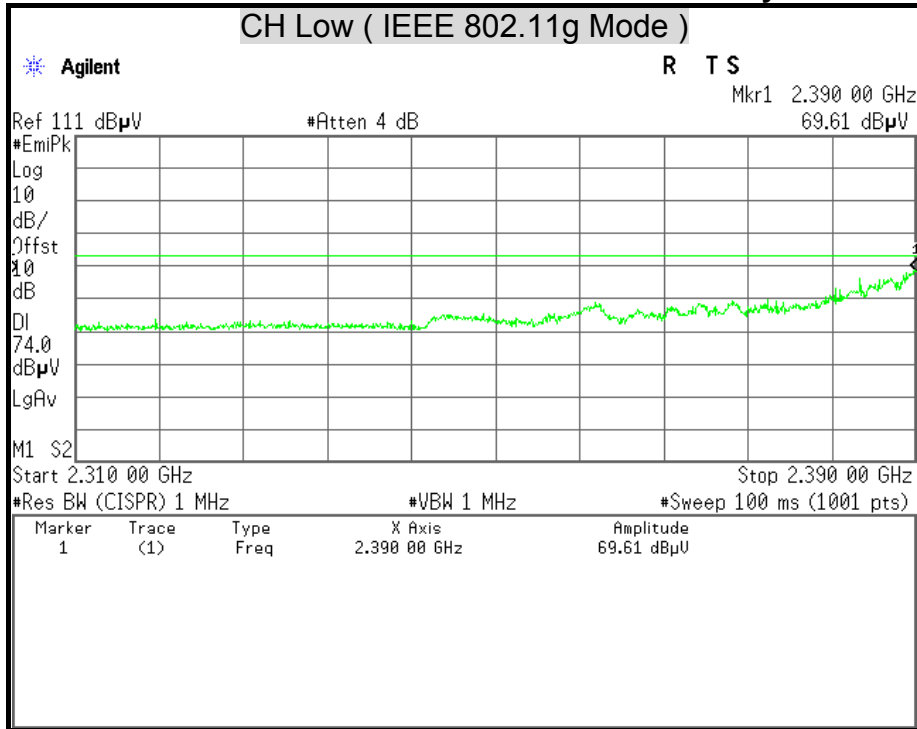

- Remark:** 1. Correction Factor (dB/m) = Antenna Factor (dB/m) + Cable Loss (dB) – PreAmp.Gain (dB)  
 2. The correction factor was entered as an offset in the spectrum analyzer to allow for direct reading of power.

Detector Mode : Average

Polarity : Vertical

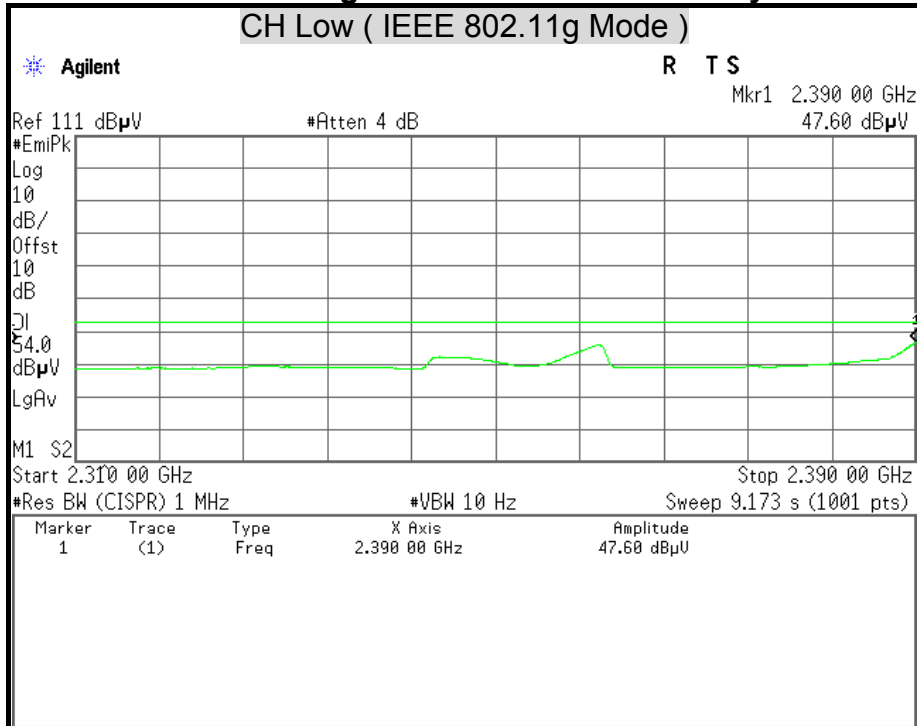

- Remark:** 1. Correction Factor (dB/m) = Antenna Factor (dB/m) + Cable Loss (dB) – PreAmp.Gain (dB)  
 2. The correction factor was entered as an offset in the spectrum analyzer to allow for direct reading of power.



Detector Mode : Peak

Polarity : Horizontal

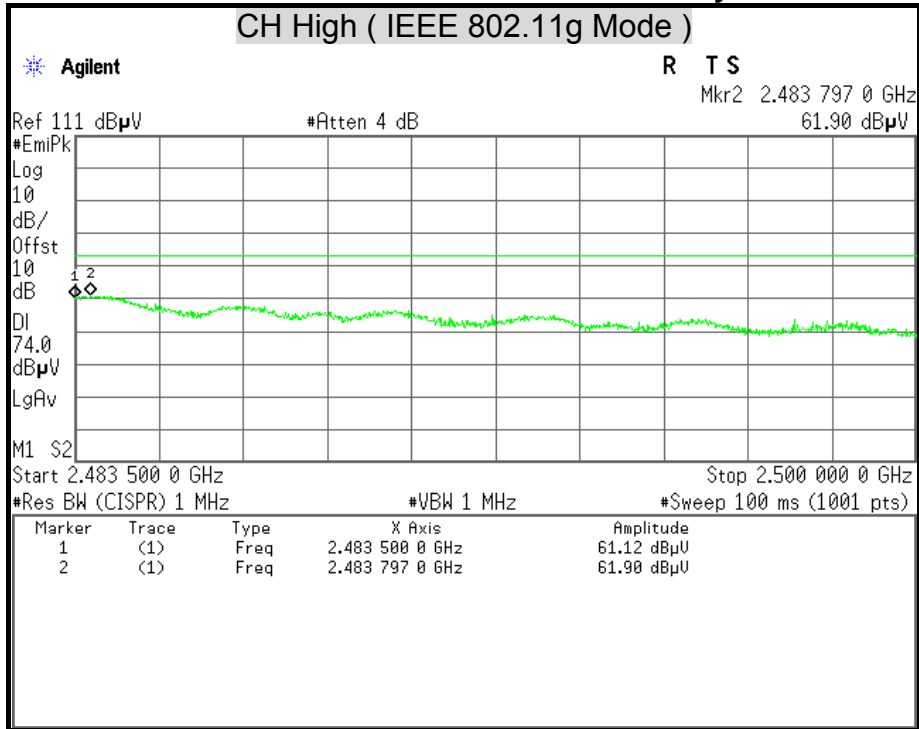

- Remark:** 1. Correction Factor (dB/m) = Antenna Factor (dB/m) + Cable Loss (dB) – PreAmp.Gain (dB)  
 2. The correction factor was entered as an offset in the spectrum analyzer to allow for direct reading of power.

Detector Mode : Average

Polarity : Horizontal

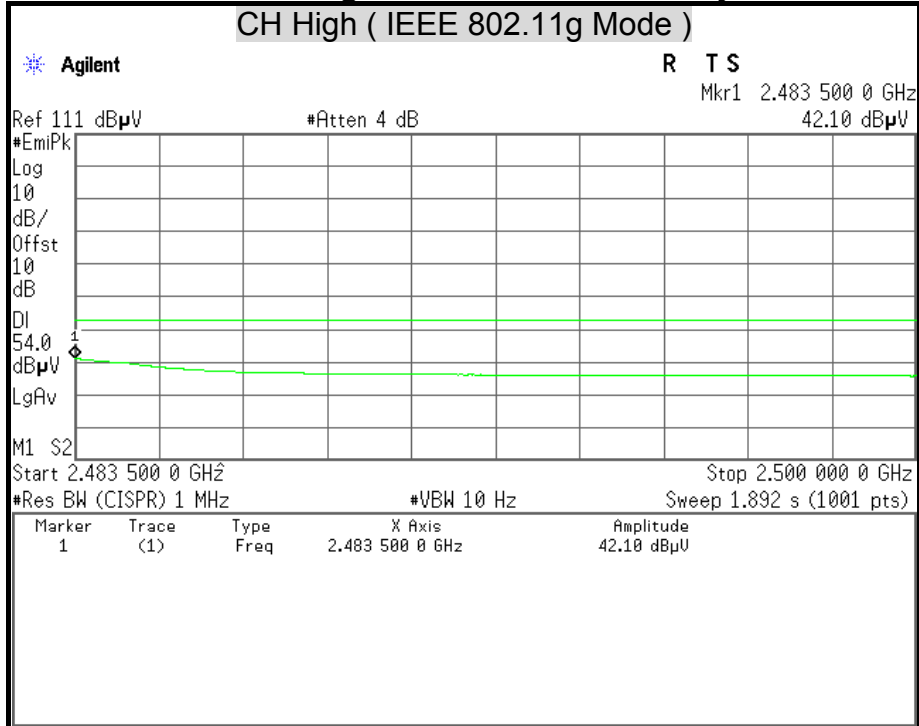

- Remark:** 1. Correction Factor (dB/m) = Antenna Factor (dB/m) + Cable Loss (dB) – PreAmp.Gain (dB)  
 2. The correction factor was entered as an offset in the spectrum analyzer to allow for direct reading of power.



Detector Mode : Peak

Polarity : Vertical

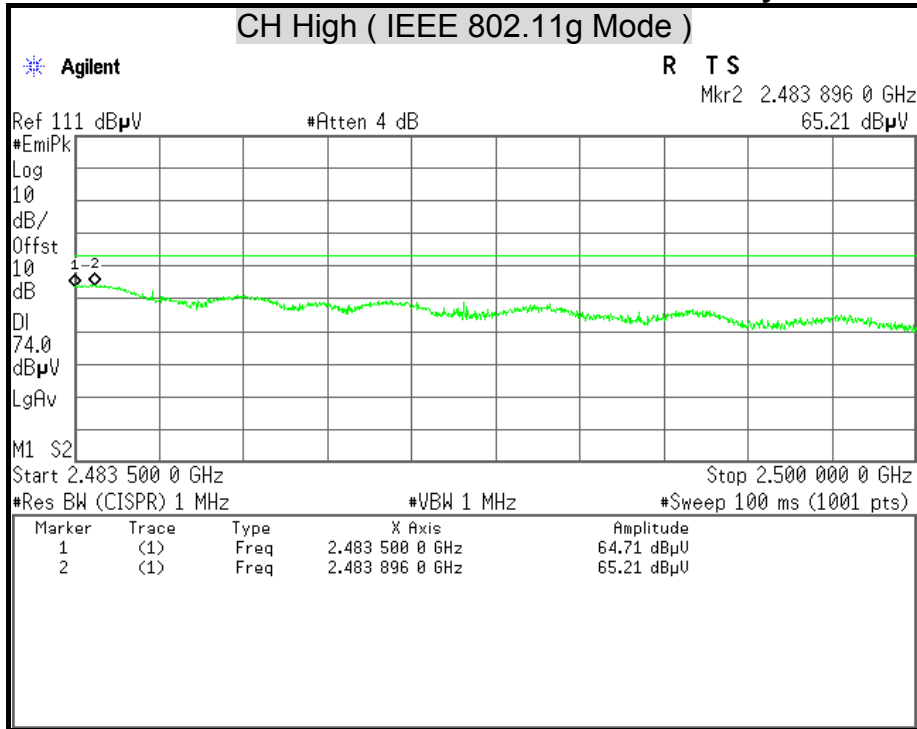

- Remark:** 1. Correction Factor (dB/m) = Antenna Factor (dB/m) + Cable Loss (dB) – PreAmp.Gain (dB)  
 2. The correction factor was entered as an offset in the spectrum analyzer to allow for direct reading of power.

Detector Mode : Average

Polarity : Vertical

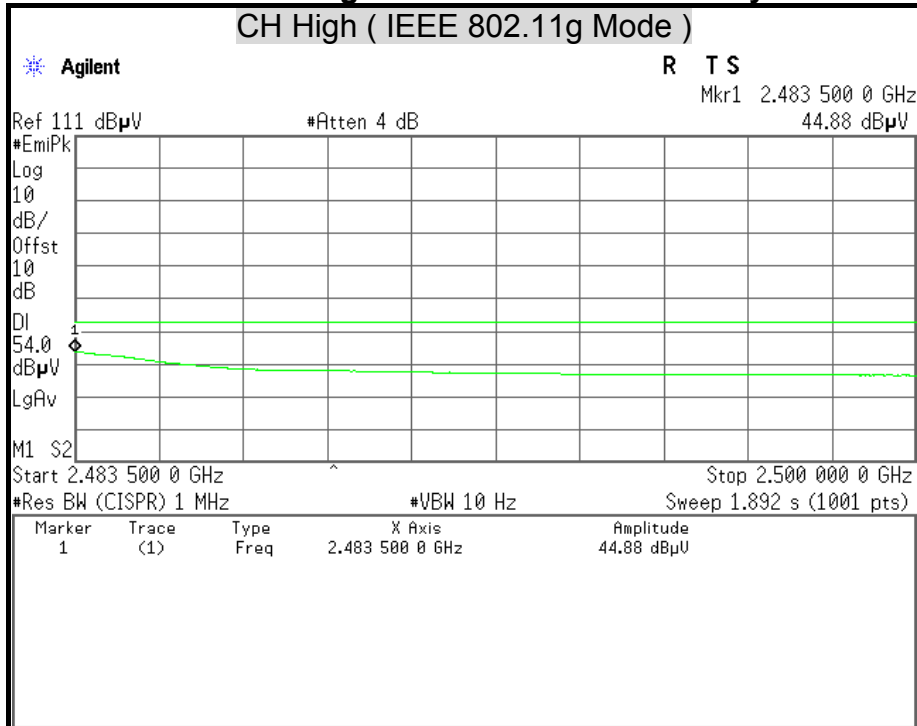

- Remark:** 1. Correction Factor (dB/m) = Antenna Factor (dB/m) + Cable Loss (dB) – PreAmp.Gain (dB)  
 2. The correction factor was entered as an offset in the spectrum analyzer to allow for direct reading of power.



Detector Mode : Peak

Polarity : Horizontal

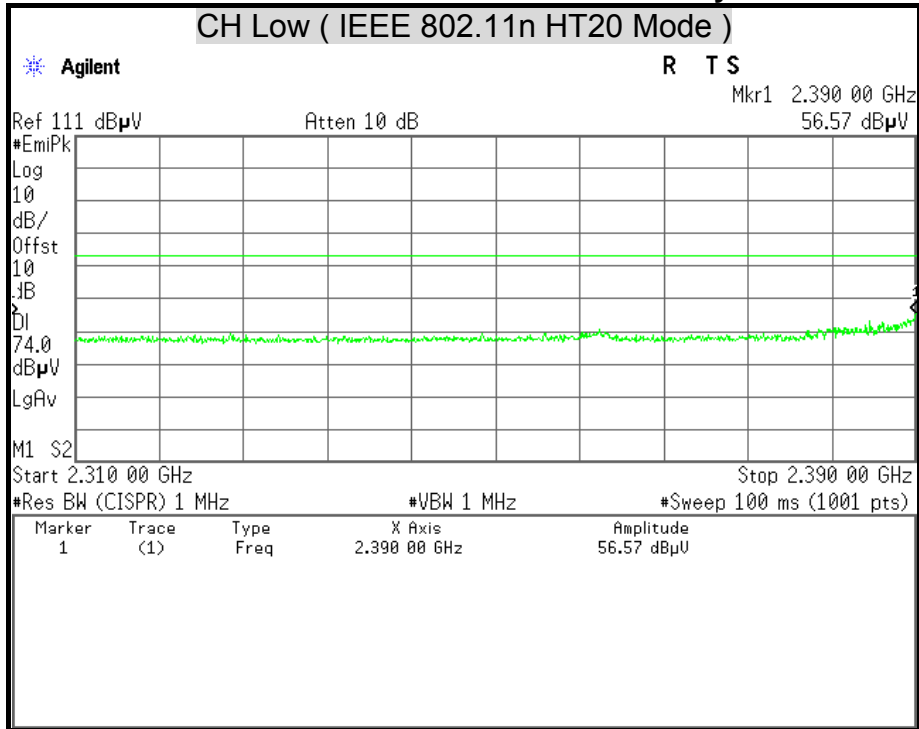

- Remark:** 1. Correction Factor (dB/m) = Antenna Factor (dB/m) + Cable Loss (dB) – PreAmp.Gain (dB)  
2. The correction factor was entered as an offset in the spectrum analyzer to allow for direct reading of power.

Detector Mode : Average

Polarity : Horizontal

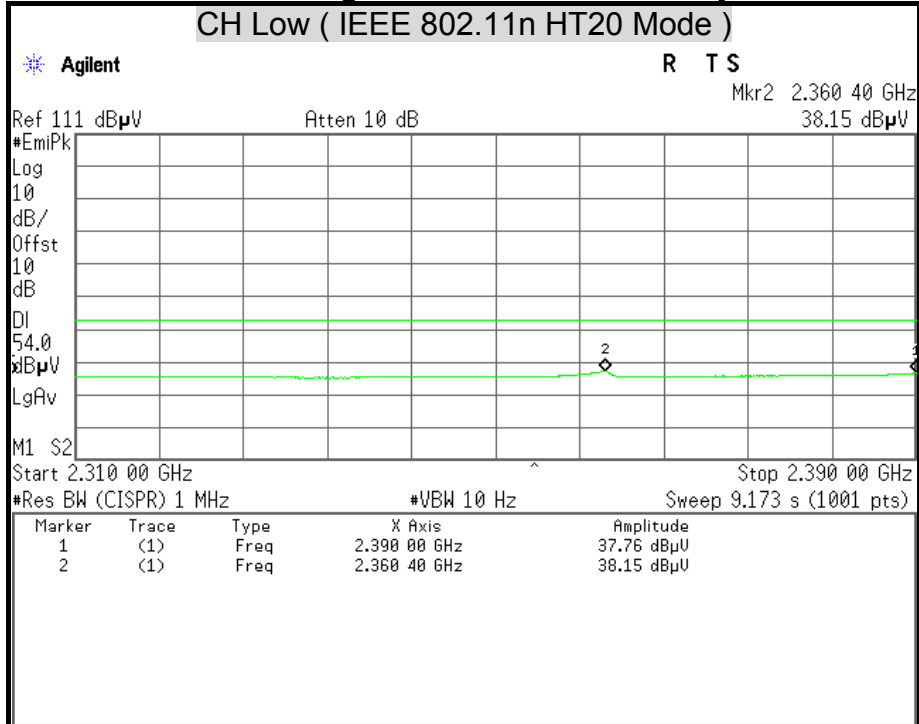

- Remark:** 1. Correction Factor (dB/m) = Antenna Factor (dB/m) + Cable Loss (dB) – PreAmp.Gain (dB)  
2. The correction factor was entered as an offset in the spectrum analyzer to allow for direct reading of power.





Detector Mode : Peak

Polarity : Vertical

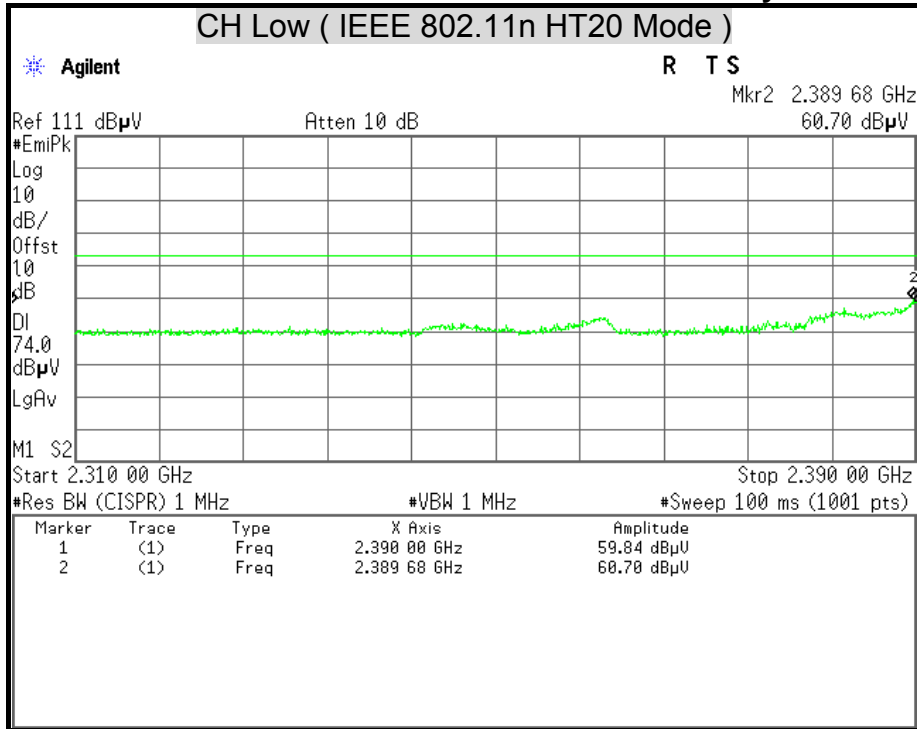

- Remark:** 1. Correction Factor (dB/m) = Antenna Factor (dB/m) + Cable Loss (dB) – PreAmp.Gain (dB)  
 2. The correction factor was entered as an offset in the spectrum analyzer to allow for direct reading of power.

Detector Mode : Average

Polarity : Vertical

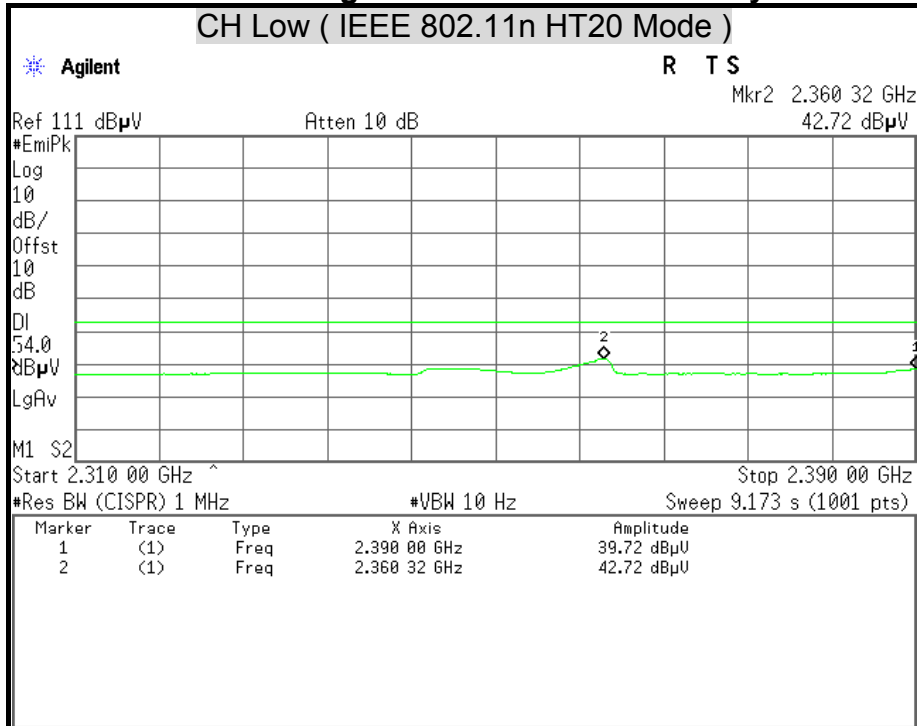

- Remark:** 1. Correction Factor (dB/m) = Antenna Factor (dB/m) + Cable Loss (dB) – PreAmp.Gain (dB)  
 2. The correction factor was entered as an offset in the spectrum analyzer to allow for direct reading of power.



Detector Mode : Peak

Polarity : Horizontal

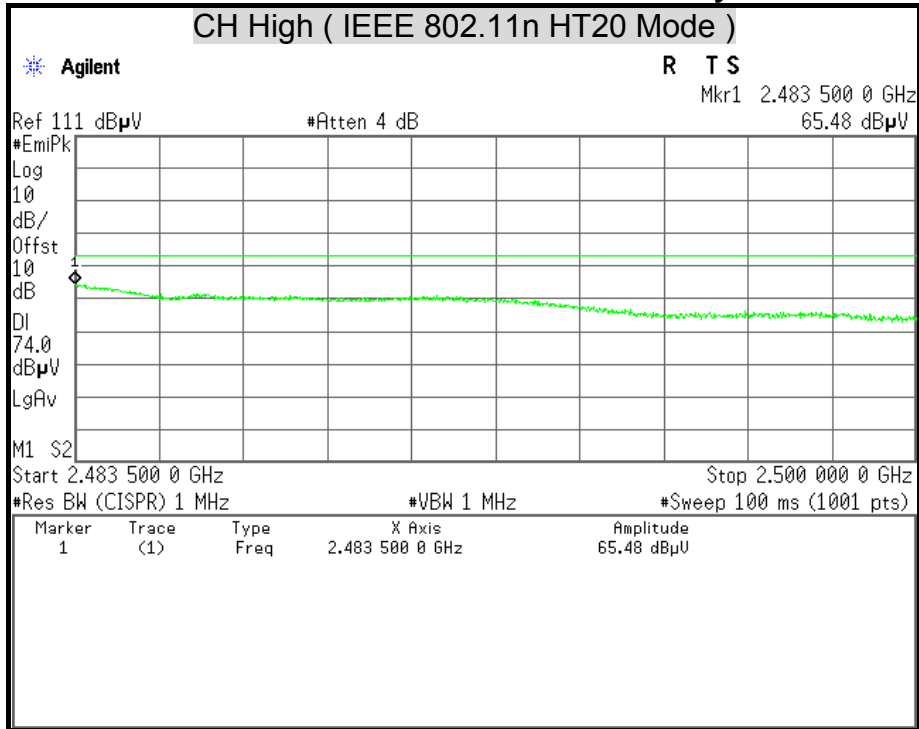

- Remark:** 1. Correction Factor (dB/m) = Antenna Factor (dB/m) + Cable Loss (dB) – PreAmp.Gain (dB)
2. The correction factor was entered as an offset in the spectrum analyzer to allow for direct reading of power.

Detector Mode : Average

Polarity : Horizontal

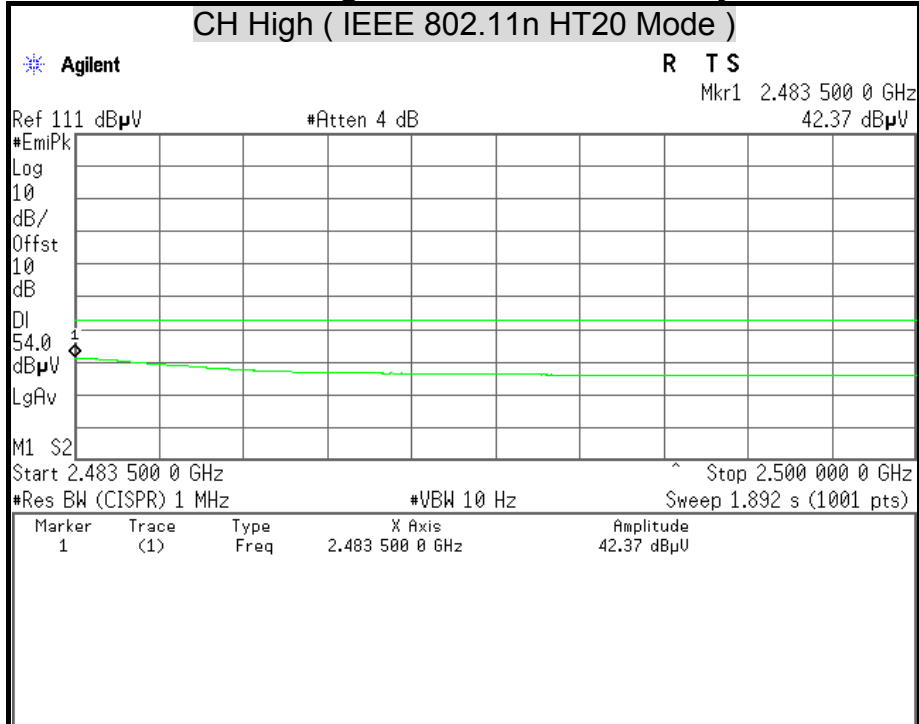

- Remark:** 1. Correction Factor (dB/m) = Antenna Factor (dB/m) + Cable Loss (dB) – PreAmp.Gain (dB)
2. The correction factor was entered as an offset in the spectrum analyzer to allow for direct reading of power.



Detector Mode : Peak

Polarity : Vertical

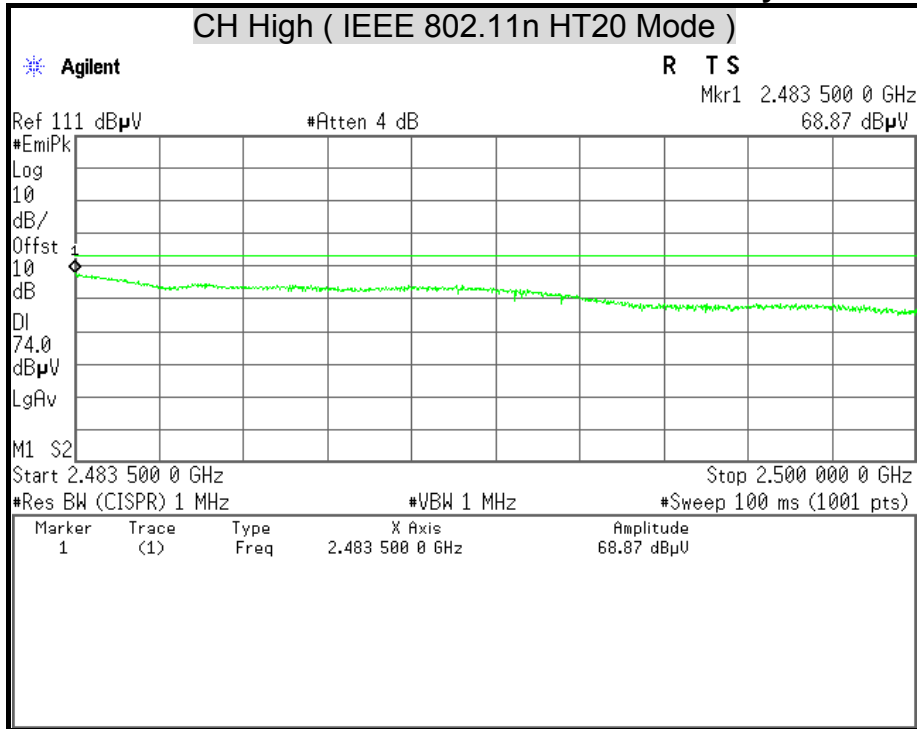

- Remark:** 1. Correction Factor (dB/m) = Antenna Factor (dB/m) + Cable Loss (dB) – PreAmp.Gain (dB)  
2. The correction factor was entered as an offset in the spectrum analyzer to allow for direct reading of power.

Detector Mode : Average

Polarity : Vertical

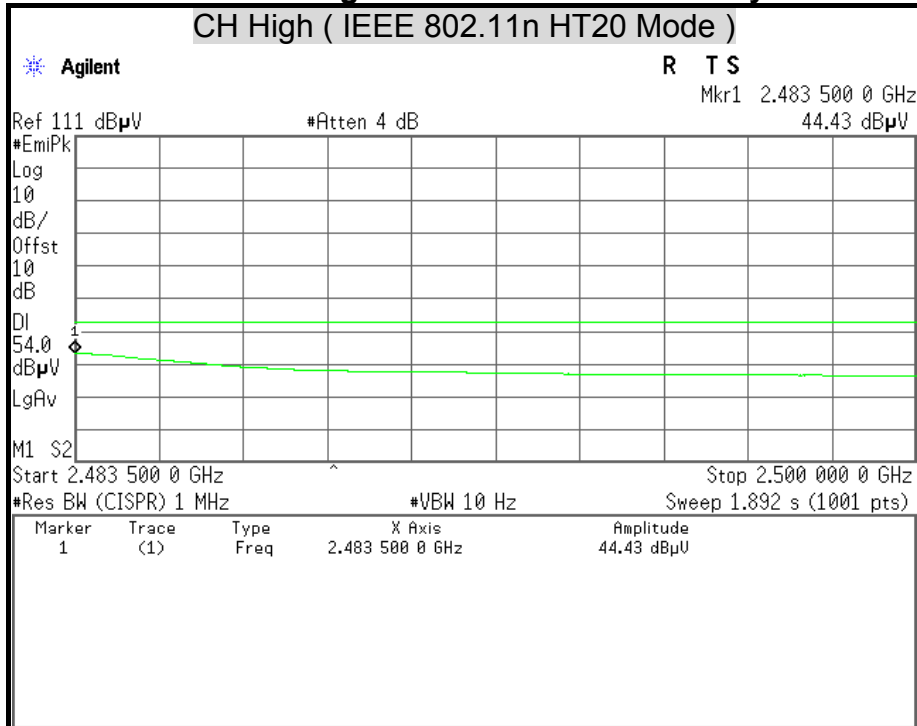

- Remark:** 1. Correction Factor (dB/m) = Antenna Factor (dB/m) + Cable Loss (dB) – PreAmp.Gain (dB)  
2. The correction factor was entered as an offset in the spectrum analyzer to allow for direct reading of power.



## 7.7 CONDUCTED EMISSION

### LIMITS

§ 15.207 (a) Except as shown in paragraph (b) and (c) this section, for an intentional radiator that is designed to be connected to the public utility (AC) power line, the radio frequency voltage that is conducted back onto the AC power line on any frequency or frequencies within the band 150 kHz to 30 MHz shall not exceed the limits in the following table, as measured using a 50 µH/50 ohms line impedance stabilization network (LISN). Compliance with the provisions of this paragraph shall be based on the measurement of the radio frequency voltage between each power line and ground at the power terminal. The lower limit applies at the boundary between the frequency ranges.

Frequency Range (MHz)	Conducted Limit (dBµv)	
	Quasi-peak	Average
0.15 - 0.50	66 to 56	56 to 46
0.50 - 5.00	56	46
5.00 - 30.0	60	50

### TEST EQUIPMENT

Name of Equipment	Manufacturer	Model	Serial Number	Calibration Due
L.I.S.N	SCHWARZBECK	NSLK 8127	8127-465	08/11/2014
L.I.S.N	SCHWARZBECK	NSLK 8127	8127-473	03/10/2015
EMI Test Receiver	ROHDE & SCHWARZ	ESHS 30	838550/003	11/07/2014
Pulse Limiter	ROHDE & SCHWARZ	ESH3-Z2	100117	07/01/2014

*Remark: Each piece of equipment is scheduled for calibration once a year.*



**TEST SETUP**

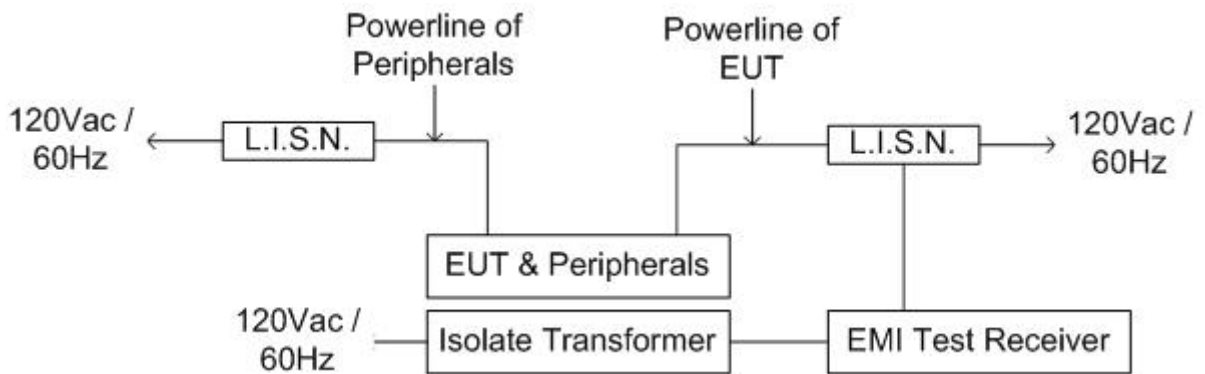
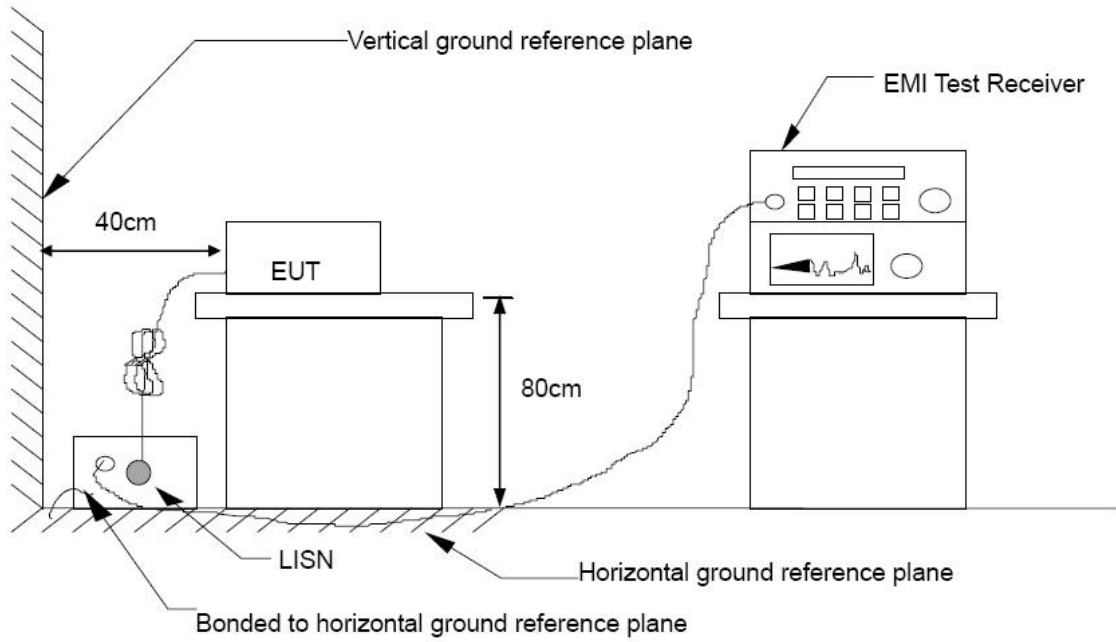



## **TEST PROCEDURE**

The basic test procedure was in accordance with ANSI C63.10:2009.

The test procedure is performed in a 4m × 3m × 2.4m (L×W×H) shielded room.

The EUT along with its peripherals were placed on a 1.0m (W) × 1.5m (L) and 0.8m in height wooden table and the EUT was adjusted to maintain a 0.4 meter space from a vertical reference plane.

The EUT was connected to power mains through a line impedance stabilization network (LISN) which provides 50 ohm coupling impedance for measuring instrument and the chassis ground was bounded to the horizontal ground plane of shielded room. All peripherals were connected to the second LISN and the chassis ground also bounded to the horizontal ground plane of shielded room.

The EUT was located so that the distance between the boundary of the EUT and the closest surface of the LISN is 0.8 m. Where a mains flexible cord was provided by the manufacturer shall be 1 m long, or if in excess of 1 m, the excess cable was folded back and forth as far as possible so as to form a bundle not exceeding 0.4 m in length.



TEST RESULTS

Product Name	WiFi Baby Cam	Test By	Ted Wu
Test Model	TV-IP743SIC	Test Date	2014/04/24
Test Mode	Normal Operating (Full Function)	Temp. & Humidity	22 °C, 63%

LINE

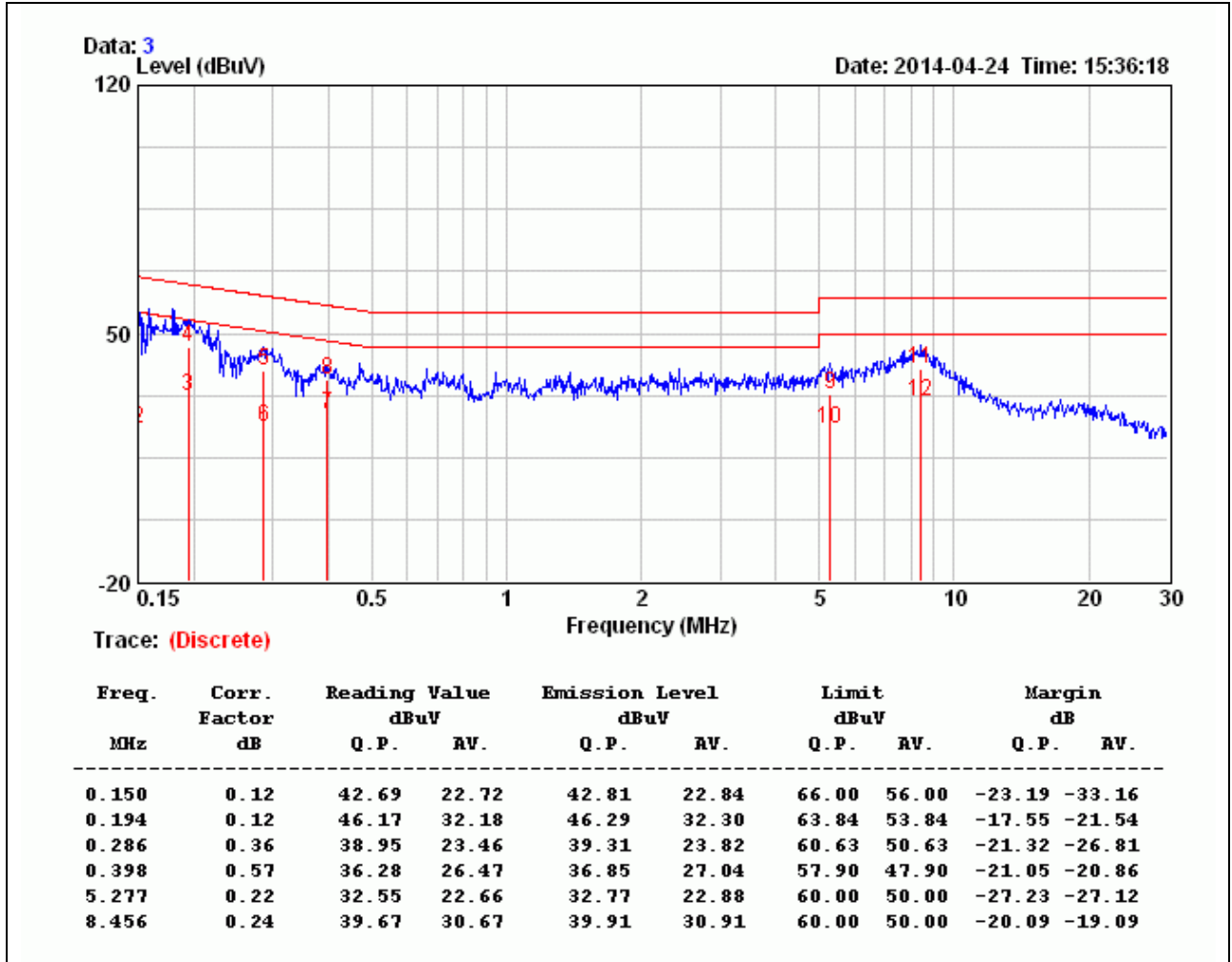

Remark:

1. Correction Factor = Insertion loss + Cable loss
2. Emission level = Reading Value + Correction factor
3. Margin value = Emission level – Limit value



<b>Product Name</b>	WiFi Baby Cam	<b>Test By</b>	Ted Wu
<b>Test Model</b>	TV-IP743SIC	<b>Test Date</b>	2014/04/24
<b>Test Mode</b>	Normal Operating (Full Function)	<b>Temp. &amp; Humidity</b>	22°C, 63%

NEUTRAL

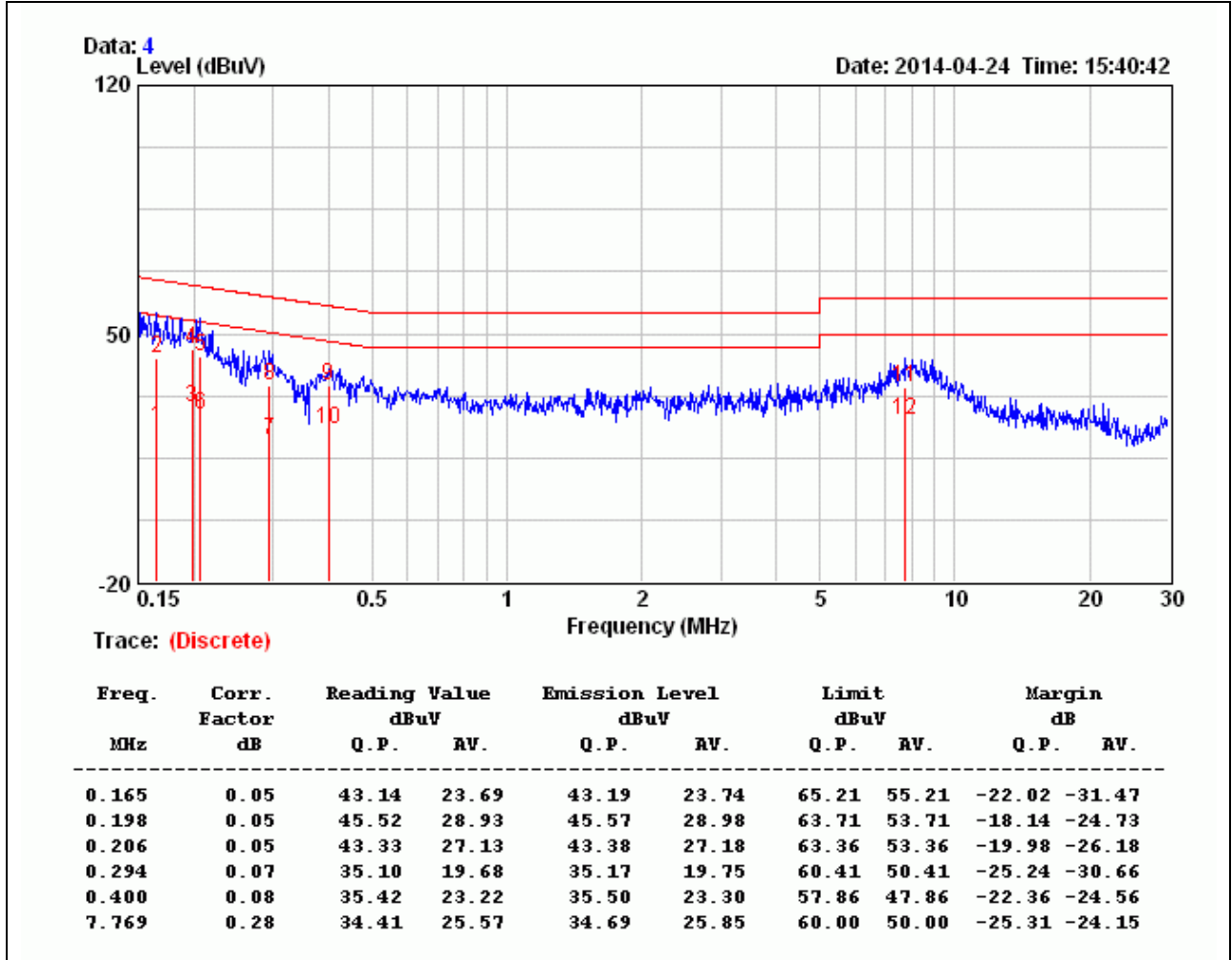

Remark:

1. Correction Factor = Insertion loss + Cable loss
2. Emission level = Reading Value + Correction factor
3. Margin value = Emission level - Limit value