



Test Report

Product Name : TV-IP551W: Wireless N Internet Camera
TV-IP551WI: Wireless N Day/Night Internet Camera
Model No. : TV-IP551W, TV-IP551WI
FCC ID. : XU8TVIP551

Applicant : TRENDnet, INC
Address : 20675 Manhattan Place, Torrance, CA 90501 U.S.A.

Date of Receipt : 2011/09/28
Issued Date : 2011/10/31
Report No. : 11A189R-RFUSP42V01
Report Version : V1.0

The test results relate only to the samples tested.
The test report shall not be reproduced except in full without the written approval of Quietek Corporation.

Test Report Certification

Issued Date : 2011/10/31

Report No. : 11A189R-RFUSP42V01

Quietek

Product Name : TV-IP551W: Wireless N Internet Camera
TV-IP551WI: Wireless N Day/Night Internet Camera

Applicant : TRENDnet, INC

Address : 20675 Manhattan Place, Torrance, CA 90501 U.S.A.

Model No. : TV-IP551W, TV-IP551WI

FCC ID. : XU8TVIP551

EUT Voltage : AC 100-240V, 50/60Hz

Trade Name : TRENDnet

Applicable Standard : FCC CFR Title 47 Part 15 Subpart C Section 15.247: 2010

Test Result : Complied

The test results relate only to the samples tested.

The test report shall not be reproduced except in full without the written approval of Quietek Corporation.

Documented By :



(Demi Chang / Engineering Adm. Specialist)

Reviewed By :



(Quale Tang / Engineer)

Approved By :

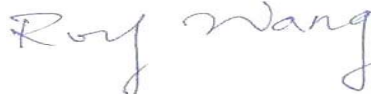

(Roy Wang / Manager)

TABLE OF CONTENTS

Description	Page
1. General Information.....	5
1.1. EUT Description	5
1.2. Operational Description	9
1.3. Test Mode	10
1.4. Tested System Details	11
1.5. Configuration of tested System	11
1.6. EUT Exercise Software	12
1.7. Test Facility.....	13
2. Conducted Emission	14
2.1. Test Equipment.....	14
2.2. Test Setup	14
2.3. Limits	15
2.4. Test Procedure	15
2.5. Test Specification.....	15
2.6. Uncertainty	15
2.7. Test Result.....	16
2.8. Test Photo	18
3. Peak Power Output	19
3.1. Test Equipment.....	19
3.2. Test Setup	19
3.3. Test procedures	19
3.4. Limits	19
3.5. Test Specification.....	19
3.6. Uncertainty	19
3.7. Test Result.....	20
4. Radiated Emission	24
4.1. Test Equipment.....	24
4.2. Test Setup	24
4.3. Limits	25
4.4. Test Procedure	25
4.5. Test Specification.....	25
4.6. Uncertainty	25
4.7. Test Result.....	26
4.8. Test Photo	58
5. RF antenna conducted test	60
5.1. Test Equipment.....	60
5.2. Test Setup	60
5.3. Limits	61
5.4. Test Procedure	61
5.5. Test Specification.....	61
5.6. Uncertainty	61
5.7. Test Result.....	62
6. Radiated Emission Band Edge.....	78
6.1. Test Equipment.....	78

6.2.	Test Setup	78
6.3.	Limits	79
6.4.	Test Procedure	79
6.5.	Test Specification.....	79
6.6.	Uncertainty	79
6.7.	Test Result.....	80
7.	Occupied Bandwidth	112
7.1.	Test Equipment.....	112
7.2.	Test Setup	112
7.3.	Test Procedures	112
7.4.	Limits	112
7.5.	Test Specification.....	112
7.6.	Uncertainty	112
7.7.	Test Result.....	113
8.	Power Density	125
8.1.	Test Equipment.....	125
8.2.	Test Setup	125
8.3.	Limits	125
8.4.	Test Procedures	125
8.5.	Test Specification.....	125
8.6.	Uncertainty	125
8.7.	Test Result.....	126
Attachement.....		140
	EUT Photograph.....	140

1. General Information

1.1. EUT Description

Product Name	TV-IP551W: Wireless N Internet Camera TV-IP551WI: Wireless N Day/Night Internet Camera
Product Type	WLAN (1TX, 1RX)
Trade Name	TRENDnet
Model No.	TV-IP551W, TV-IP551WI
Frequency Range -IEEE 802.11b/g & IEEE 802.11n (20MHz)	2412~2462MHz
Frequency Range-IEEE 802.11n (40MHz)	2422~2452MHz
Channel Number (IEEE 802.11b/g & IEEE 802.11n (20MHz))	11
Channel Number-IEEE 802.11n (40MHz)	7
Type of Modulation (IEEE 802.11b)	Direct Sequence Spread Spectrum (DSSS)
Type of Modulation (IEEE 802.11g/n)	Orthogonal Frequency Division Multiplexing (OFDM)
Data Speed (IEEE 802.11b)	1Mbps, 2Mbps, 5.5Mbps, 11Mbps
Data Speed (IEEE 802.11g)	6Mbps,9Mbps,12Mbps,18Mbps,24Mbps,36Mbps,48Mbps,54Mbps
Data Speed (IEEE 802.11n)	Support a subset of the combination of GI, MCS 0~MCS 7 and bandwidth defined in 802.11n
Antenna Gain	2dBi
Channel Control	Manual
Antenna Type	PCB type
LAN Cable	Non-Shielded, 1.8m
Power Adapter	AMIGO, AMS1-0501200FU I/P: 100-240V~ 50/60Hz 0.2A O/P: 5V == 1.2A Cable Out: Non-Shielded, 1.5m

ANT-TX / Rx & Bandwidth

ANT-TX / Rx	TX		Rx	
	20MHz	40MHz	20MHz	40MHz
IEEE802.11b	✓		✓	
IEEE802.11g	✓			
IEEE802.11n	✓	✓	✓	✓



IEEE802.11n Spec.

MCS Index	Modulation	R	N _{BPSCS}	N _{CBPS}		N _{DBPS}		Data Rate(Mb/s)			
				20MHz	40MHz	20MHz	40MHz	800ns GI		400ns GI (Note1)	
								20MHz	40MHz	20MHz	40MHz
0	BPSK	1/2	1	52	108	26	54	6.5	13.5	7.2	15.0
1	QPSK	1/2	2	104	216	52	108	13.0	27.0	14.4	30.0
2	QPSK	3/4	2	104	216	78	162	19.5	40.5	21.7	45.0
3	16-QAM	1/2	4	208	432	104	216	26.0	54.0	28.9	60.0
4	16-QAM	3/4	4	208	432	156	324	39.0	81.0	43.3	90.0
5	64-QAM	2/3	6	312	648	208	432	52.0	108.0	57.8	120.0
6	64-QAM	3/4	6	312	648	234	486	58.5	121.5	65.0	135.0
7	64-QAM	5/6	6	312	648	260	540	65.0	135.0	72.2	150.0

Note 1: Support of 400ns GI is optional on transmit and receive.

Table 1 – MCS parameters for TX Antenna number = 1

MCS Index	Modulation	R	N _{BPSCS}	N _{CBPS}		N _{DBPS}		Data Rate(Mb/s)			
				20MHz	40MHz	20MHz	40MHz	800ns GI		400ns GI (Note1)	
								20MHz	40MHz	20MHz	40MHz
8	BPSK	1/2	1	104	216	52	108	13.0	27.0	14.4	30.0
9	QPSK	1/2	2	208	432	104	216	26.0	54.0	28.9	60.0
10	QPSK	3/4	2	208	432	156	324	39.0	81.0	43.3	90.0
11	16-QAM	1/2	4	416	864	208	432	52.0	108.0	57.8	120.0
12	16-QAM	3/4	4	416	864	312	648	78.0	162.0	86.7	180.0
13	64-QAM	2/3	6	624	1296	416	864	104.0	216.0	115.6	240.0
14	64-QAM	3/4	6	624	1296	468	972	117.0	243.0	130.0	270.0
15	64-QAM	5/6	6	624	1296	520	1080	130.0	270.0	144.4	300.0

Note 1: Support of 400ns GI is optional on transmit and receive.

Table 2 – MCS parameters for TX Antenna number = 2

Symbol	Explanation
R	Code rate
N _{BPSC}	Number of coded bits per single carrier
N _{CBPS}	Number of coded bits per symbol
N _{DBPS}	Number of data bits per symbol
GI	guard interval

IEEE 802.11b/g & IEEE 802.11n (20MHz)

Working Frequency of Each Channel							
Channel	Frequency	Channel	Frequency	Channel	Frequency	Channel	Frequency
001	2412 MHz	002	2417 MHz	003	2422 MHz	004	2427 MHz
005	2432 MHz	006	2437 MHz	007	2442 MHz	008	2447 MHz
009	2452 MHz	010	2457 MHz	011	2462 MHz		

IEEE 802.11n (40MHz)

Working Frequency of Each Channel							
Channel	Frequency	Channel	Frequency	Channel	Frequency	Channel	Frequency
003	2422 MHz	004	2427 MHz	005	2432 MHz	006	2437 MHz
007	2442 MHz	008	2447 MHz	009	2452 MHz		

Note:

1. These devices are TV-IP551W: Wireless N Internet Camera, TV-IP551WI: Wireless N Day/Night Internet Camera, which including 2.4GHz b/g and 11n (1x1) transmitting and receiving function.
2. The different of the each model is shown as below:

Model No.	IR/ICR
TV-IP551W	Without
TV-IP551WI	With

3. After pre-test, only the worst case, TV-IP551WI, was measured in all test items.
4. These test results on a sample of the device are for the purpose of demonstrating Compliance with Part 15 Subpart C Paragraph 15.247.
5. Regards to the frequency band operation; the lowest 、 middle and highest frequency of channel were selected to perform the test, and then shown on this report.
6. This device is a composite device in accordance with Part 15 regulations. The receiving function receiving was tested and its test report number is 11A189R-RFUSP37V02 under Declaration of Conformity.

1.3. Test Mode

QuieTek has verified the construction and function in typical operation. The preliminary tests were performed in different data rate, and to find the worst condition, which was shown in this test report. The following table is the final test mode.

TX	Mode 1: Transmit
----	------------------

Test Items	Mode1	Channel	Result
Conducted Emission	11n (40MHz)	6	Complies
Peak Power Output	b/g	1 /6/ 11	Complies
	11n (20MHz)	1 /6/ 11	Complies
	11n (40MHz)	3 /6/ 9	Complies
Radiated Emission (Under 1GHz)	b/g	6	Complies
	11n (20MHz)	6	Complies
	11n (40MHz)	6	Complies
Radiated Emission (Above 1GHz)	b/g	1 /6/ 11	Complies
	11n (20MHz)	1 /6/ 11	Complies
	11n (40MHz)	3 /6/ 9	Complies
RF antenna conducted test	b/g	1 /11	Complie
	11n (20MHz)	1 /11	Complies
	11n (40MHz)	3 /9	Complies
Radiated Emission Band Edge	b/g	1 /11	Complies
	11n (20MHz)	1 /11	Complies
	11n (40MHz)	3 /9	Complies
Occupied Bandwidth	b/g	1 /6/ 11	Complies
	11n (20MHz)	1 /6/ 11	Complies
	11n (40MHz)	3 /6/ 9	Complies
Power Density	b/g	1 /6/ 11	Complies
	11n (20MHz)	1 /6/ 11	Complies
	11n (40MHz)	3 /6/ 9	Complies

1.4. Tested System Details

The types for all equipments, plus descriptions of all cables used in the tested system (including inserted cards) are:

Product	Manufacturer	Model No.	Serial No.	FCC ID	Power Cord
1 PC	ACER	MS2296	LUSEW0D03711 05FE221601	DoC	Non-Shielded, 2.3m one ferrite core bonded

1.5. Configuration of tested System

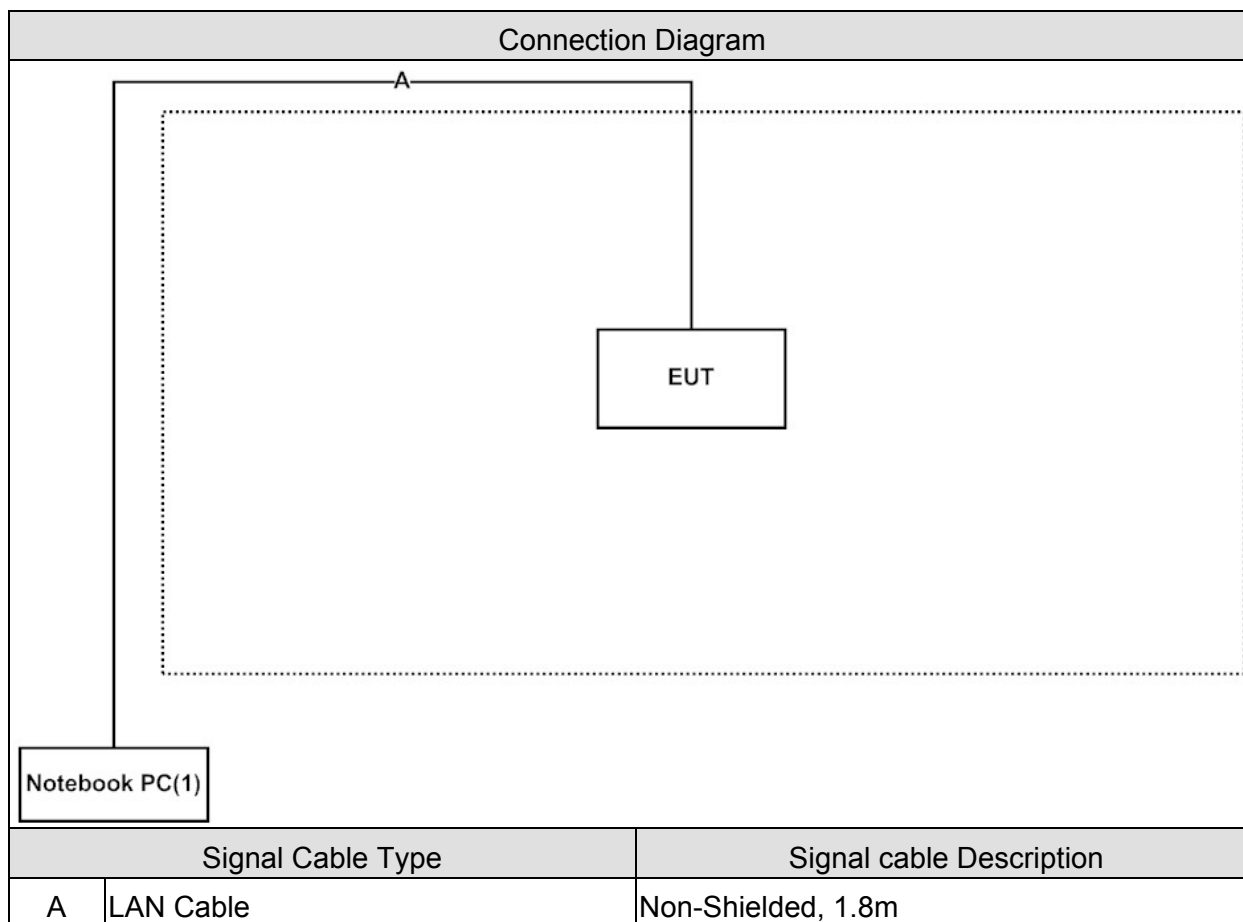

1.6. EUT Exercise Software

1	Setup the EUT as shown in Section 1.5.
2	Execute the RT3052 V1.0.0.1 on the EUT.
3	Configure the test mode, the test channel, and the data rate.
4	Press "Start TX" to start the continuous transmitting.
5	Verify that the EUT works properly.

1.7. Test Facility

Ambient conditions in the laboratory:

Items	Test Item	Required (IEC 68-1)	Actual
Temperature (°C)	FCC PART 15 C 15.207 Conducted Emission	15 - 35	20
Humidity (%RH)		25 - 75	50
Barometric pressure (mbar)		860 - 1060	950-1000
Temperature (°C)	FCC PART 15 C 15.247 Peak Power Output (DSSS)	15 - 35	25
Humidity (%RH)		25 - 75	48
Barometric pressure (mbar)		860 - 1060	950-1000
Temperature (°C)	FCC PART 15 C 15.247 Radiated Emission (DSSS)	15 - 35	25
Humidity (%RH)		25 - 75	65
Barometric pressure (mbar)		860 - 1060	950-1000
Temperature (°C)	FCC PART 15 C 15.247 RF antenna conducted test (DSSS)	15 - 35	24
Humidity (%RH)		25 - 75	49
Barometric pressure (mbar)		860 - 1060	950-1000
Temperature (°C)	FCC PART 15 C 15.247 Band Edge (DSSS)	15 - 35	25
Humidity (%RH)		25 - 75	48
Barometric pressure (mbar)		860 - 1060	950-1000
Temperature (°C)	FCC PART 15 C 15.247 Occupied Bandwidth (DSSS)	15 - 35	25
Humidity (%RH)		25 - 75	48
Barometric pressure (mbar)		860 - 1060	950-1000
Temperature (°C)	FCC PART 15 C 15.247 Power Density (DSSS)	15 - 35	25
Humidity (%RH)		25 - 75	48
Barometric pressure (mbar)		860 - 1060	950-1000

Site Description: September 27, 2010 File on
Federal Communications Commission
Laboratory Division
7435 Oakland Mills Road
Columbia, MD 21046
Registration Number: 365520



Accredited by TAF
Accreditation Number: 1313
Effective through: December 27, 2013



Site Name: Quietek Corporation

Site Address: No. 75-2, 3rd Lin, Wangye Keng, Yonghxing
Tsuen, Qionglin Shiang, Hsinchu County 307, Taiwan
TEL : 886-3-5928858 / FAX : 886-3-5928859
E-Mail : service@quietek.com

2. Conducted Emission

2.1. Test Equipment

The following test equipments are used during the test:

Conducted Emission / SR3

Instrument	Manufacturer	Model No.	Serial No	Next Cal.
LISN	R&S	ENV216	100096	2012/09/06
LISN	R&S	ESH3-Z5	836679/022	2012/02/10
Test Receiver	R&S	ESCS 30	825442/017	2012/01/16
Coaxial Cable	Harbour	RG-400	SR3	2012/08/14
Quietek EMI system	Quietek	Version 2.2	SR3	N/A

Note: 1. All equipments that need to calibrate are with calibration period of 1 year.

2.2. Test Setup

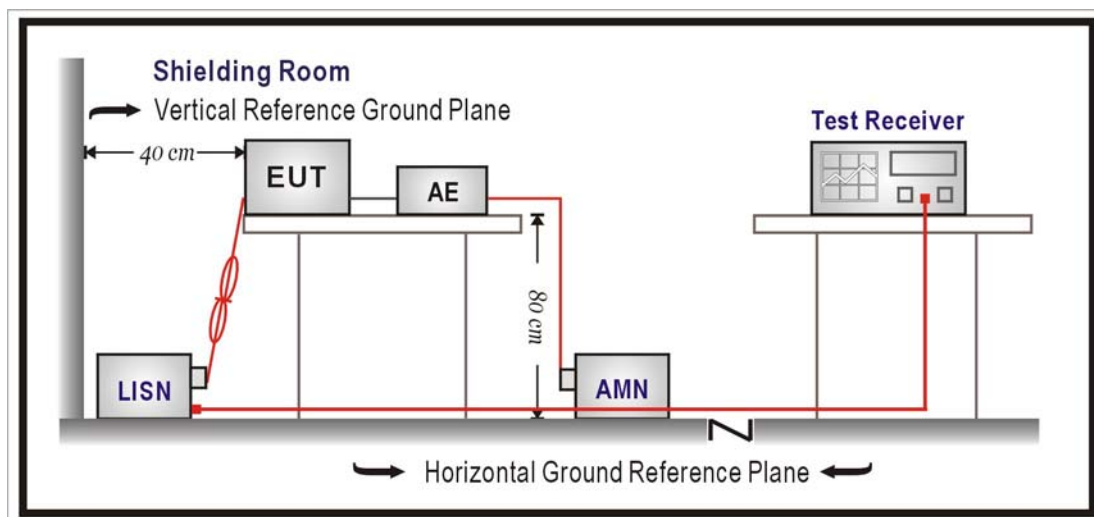

2.3. Limits

FCC Part 15 Subpart C Paragraph 15.207 Limits (dBuV)		
Frequency MHz	QP	AV
0.15 - 0.50	66-56	56-46
0.50 - 5.0	56	46
5.0 - 30	60	50

Remarks: In the above table, the tighter limit applies at the band edges.

2.4. Test Procedure

The EUT was setup according to ANSI C63.4: 2009 and tested according to DTS test procedure of Oct 2002 KDB558074 for compliance to FCC 47CFR 15.247 requirements. The EUT was placed on a platform of nominal size, 1 m by 1.5 m, raised 80 cm above the conducting ground plane. The vertical conducting plane was located 40 cm to the rear of the EUT. All other surfaces of EUT were at least 80 cm from any other grounded conducting surface. The EUT and simulators are connected to the main power through a line impedance stabilization network (LISN). The LISN provides a 50 ohm /50uH coupling impedance for the measuring equipment. The peripheral devices are also connected to the main power through a LISN. (Please refer to the block diagram of the test setup and photographs.) Each current-carrying conductor of the EUT power cord, except the ground (safety) conductor, was individually connected through a LISN to the input power source. The excess length of the power cord between the EUT and the LISN receptacle were folded back and forth at the center of the lead to form a bundle not exceeding 40 cm in length. Conducted emissions were investigated over the frequency range from 0.15MHz to 30MHz using a receiver bandwidth of 9 kHz.

2.5. Test Specification

According to FCC Part 15 Subpart C Paragraph 15.207: 2010

2.6. Uncertainty

The measurement uncertainty is defined as ± 2.26 dB.

2.7. Test Result

Site : SR3	Time : 2011/10/18 - 09:45
Limit : CISPR_B_00M_QP	Margin : 6
Probe : SR3_LISN(16A)-1_0907 - Line1	Power : AC120V/60Hz
EUT : Wireless N Day/Night Internet Camera	Note : Mode 1: Transmit

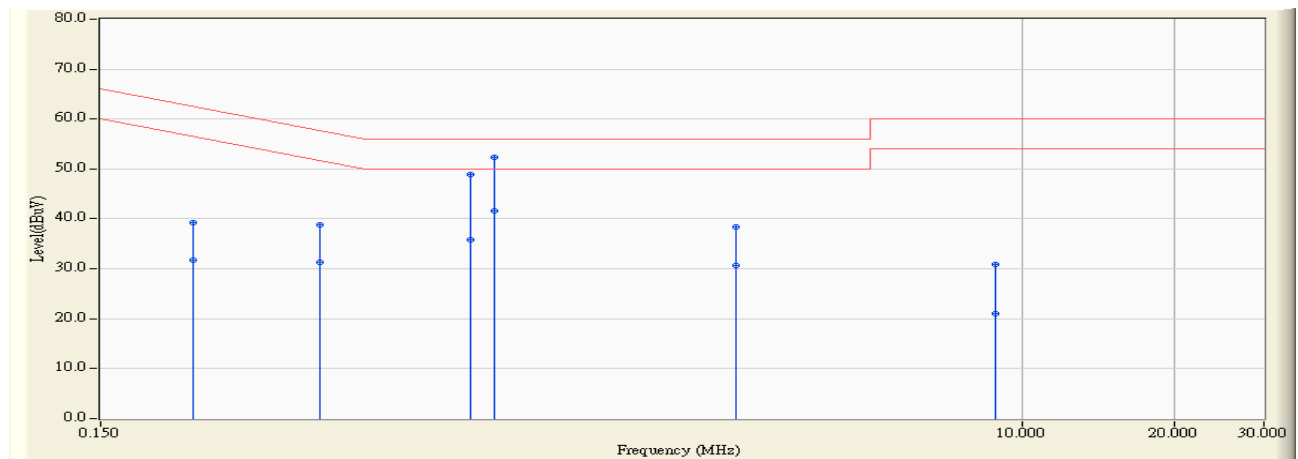

	Frequency (MHz)	Correct Factor (dB)	Reading Level (dBuV)	Measure Level (dBuV)	Margin (dB)	Limit (dBuV)	Detector Type
1	0.228	9.661	29.640	39.301	-23.217	62.518	QUASPEAK
2	0.228	9.661	22.010	31.671	-20.847	52.518	AVERAGE
3	0.408	9.687	29.210	38.897	-18.796	57.693	QUASPEAK
4	0.408	9.687	21.590	31.277	-16.416	47.693	AVERAGE
5	0.810	9.750	39.200	48.950	-7.050	56.000	QUASPEAK
6	0.810	9.750	25.990	35.740	-10.260	46.000	AVERAGE
7	* 0.900	9.764	42.500	52.264	-3.736	56.000	QUASPEAK
8	0.900	9.764	31.740	41.504	-4.496	46.000	AVERAGE
9	2.705	9.959	28.420	38.379	-17.621	56.000	QUASPEAK
10	2.705	9.959	20.720	30.679	-15.321	46.000	AVERAGE
11	8.834	10.113	20.820	30.933	-29.067	60.000	QUASPEAK
12	8.834	10.113	10.820	20.933	-29.067	50.000	AVERAGE

Note:

1. All Reading Levels are Quasi-Peak and average value.
2. " * ", means this data is the worst emission level.
3. Measurement Level = Reading Level + Correct Factor.

Site : SR3	Time : 2011/10/18 - 09:48
Limit : CISPR_B_00M_QP	Margin : 6
Probe : SR3_LISN(16A)-1_0907 - Line2	Power : AC120V/60Hz
EUT : Wireless N Day/Night Internet Camera	Note : Mode 1: Transmit

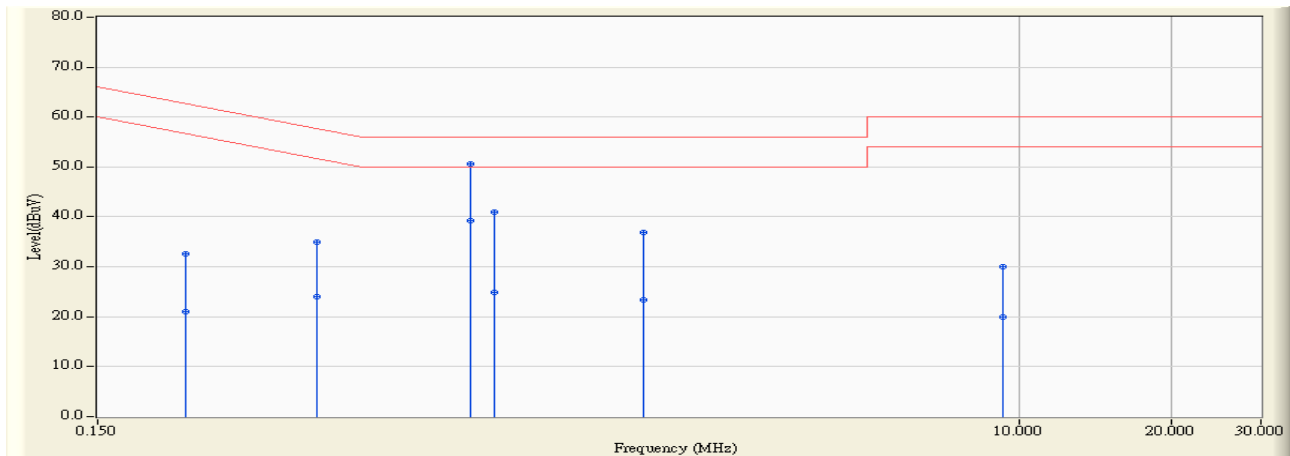

	Frequency (MHz)	Correct Factor (dB)	Reading Level (dBuV)	Measure Level (dBuV)	Margin (dB)	Limit (dBuV)	Detector Type
1	0.224	9.670	22.890	32.560	-30.101	62.661	QUASPEAK
2	0.224	9.670	11.350	21.020	-31.641	52.661	AVERAGE
3	0.408	9.697	25.370	35.067	-22.626	57.693	QUASPEAK
4	0.408	9.697	14.250	23.947	-23.746	47.693	AVERAGE
5	* 0.822	9.755	40.840	50.595	-5.405	56.000	QUASPEAK
6	0.822	9.755	29.520	39.275	-6.725	46.000	AVERAGE
7	0.913	9.768	31.140	40.908	-15.092	56.000	QUASPEAK
8	0.913	9.768	15.200	24.968	-21.032	46.000	AVERAGE
9	1.802	9.900	26.920	36.820	-19.180	56.000	QUASPEAK
10	1.802	9.900	13.510	23.410	-22.590	46.000	AVERAGE
11	9.279	10.175	19.870	30.045	-29.955	60.000	QUASPEAK
12	9.279	10.175	9.690	19.865	-30.135	50.000	AVERAGE

Note:

1. All Reading Levels are Quasi-Peak and average value.
2. " * ", means this data is the worst emission level.
3. Measurement Level = Reading Level + Correct Factor.

3. Peak Power Output

3.1. Test Equipment

The following test equipments are used during the test:

Peak Power Output / SR7

Instrument	Manufacturer	Model No.	Serial No	Next Cal. Date
Power Meter	Agilent	N1911A	MY45101353	2012/01/04
Power Sensor	Agilent	N1921A	MY45241670	2012/01/04

Note: 1. All equipments that need to calibrate are with calibration period of 1 year.

3.2. Test Setup

IEEE 802.11 b / g / n (20M / 40M) MODE

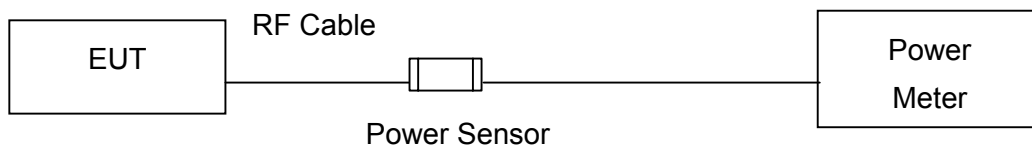

3.3. Test procedures

The EUT was tested according to DTS test procedure of Oct 2002 KDB558074 for compliance to FCC 47CFR 15.247 requirements.

3.4. Limits

The maximum peak power shall be less 1 Watt.

3.5. Test Specification

According to FCC Part 15 Subpart C Paragraph 15.247: 2010

3.6. Uncertainty

The measurement uncertainty is defined as ± 1.27 dB.

3.7. Test Result

Product	Wireless N Day/Night Internet Camera		
Test Item	Peak Power Output		
Test Mode	Transmit		
Date of Test	2011/09/30	Test Site	SR7

IEEE 802.11b				
Channel No.	Frequency (MHz)	Measure Level (dBm)	Limit (dBm)	Result
1	2412	17.98	1Watt= 30 dBm	Pass
6	2437	18.03	1Watt= 30 dBm	Pass
11	2462	18.21	1Watt= 30 dBm	Pass

The worst emission of data rate is 1Mbps.

Peak Power Output Value (dBm)						
Channel No.	Frequency (MHz)	Data Rate				Required Limit
		1	2	5.5	11	
1	2412.00	17.98	--	--	-	1Watt= 30 dBm
6	2437.00	18.03	18.00	17.92	17.90	1Watt= 30 dBm
11	2462.00	18.21	--	--	-	1Watt= 30 dBm

Note: Measure Level =Reading value + cable loss

Product	Wireless N Day/Night Internet Camera		
Test Item	Peak Power Output		
Test Mode	Transmit		
Date of Test	2011/09/30	Test Site	SR7

IEEE 802.11g				
Channel No.	Frequency (MHz)	Measure Level (dBm)	Limit (dBm)	Result
1	2412	21.48	1Watt= 30 dBm	Pass
6	2437	21.75	1Watt= 30 dBm	Pass
11	2462	20.66	1Watt= 30 dBm	Pass

The worst emission of data rate is 6Mbps.

Peak Power Output Value(dBm)									
Channel No.	Frequency (MHz)	Data Rate (Mbps)							Required Limit
		6	12	18	24	36	48	54	
1	2412.00	21.48	--	--	--	--	--	--	1Watt= 30 dBm
6	2437.00	21.75	21.73	21.71	21.62	21.60	21.57	21.55	1Watt= 30 dBm
11	2462.00	20.66	--	--	--				1Watt= 30 dBm

Note: Measure Level =Reading value + cable loss

Product	Wireless N Day/Night Internet Camera		
Test Item	Peak Power Output		
Test Mode	Transmit		
Date of Test	2011/09/30	Test Site	SR7

IEEE 802.11n 20MHz_Tx

Channel No.	Frequency (MHz)	Measure Level (dBm)	Limit (dBm)	Result
1	2412	21.38	1Watt= 30 dBm	Pass
6	2437	20.53	1Watt= 30 dBm	Pass
11	2462	19.86	1Watt= 30 dBm	Pass

The worst emission of data rate is 6.5 Mbps.

Peak Power Output (dBm)										
MCS Index		0	1	2	3	4	5	6	7	Required Limit
Channel No	Frequency (MHz)	Data Rate								
		6.5	13	19.5	26	39	52	58.5	65	
1	2412	21.38	--	--	--	--	--	--	--	30dBm
6	2437	20.53	20.51	20.49	20.46	20.42	20.40	20.37	20.32	30dBm
11	2462	19.86	--	--	--	--	--	--	--	30dBm

Product	Wireless N Day/Night Internet Camera		
Test Item	Peak Power Output		
Test Mode	Transmit		
Date of Test	2011/09/30	Test Site	SR7

IEEE802.11n 40MHz_Tx

Channel No.	Frequency (MHz)	Measure Level (dBm)	Limit (dBm)	Result
3	2422	21.58	1Watt= 30 dBm	Pass
6	2437	20.53	1Watt= 30 dBm	Pass
9	2452	20.97	1Watt= 30 dBm	Pass

The worst emission of data rate is 13.5Mbps

Peak Power Output (dBm)										
MCS Index		0	1	2	3	4	5	6	7	Required Limit
Channel No	Frequency (MHz)	Data Rate								
		13.5	27	40.5	54	81	108	121.5	135	
3	2422	21.58	--	--	-	--	--	-	--	30dBm
6	2437	20.53	20.51	20.47	20.43	20.41	20.37	20.36	20.31	30dBm
9	2452	20.97	--	--	-	--	--	-	--	30dBm

4. Radiated Emission

4.1. Test Equipment

The following test equipments are used during the test:

Radiated Emission / CB1

Instrument	Manufacturer	Model No.	Serial No	Next Cal. Date
Bilog Antenna	SCHAFFNER	CBL6112B	2895	2012/08/14
Double Ridged Guide Horn Antenna	Schwarzback	BBHA 9120D	743	2012/02/24
Pre-Amplifier	MITEQ	AMF-4D-005180-24-10P	888003	2011/12/16
Pre-Amplifier	QuieTek	AP-025C	CHM-0706049	2012/03/10
PSA Series Spectrum analyzer	Agilent	E4440A	MY46187335	2012/01/06
Coaxial Cable	Huber+Suhner AG	Sucoflex 102	25623/2	2012/03/21

Note: 1. All equipments that need to calibrate are with calibration period of 1 year.

4.2. Test Setup

Under 1GHz Test Setup:

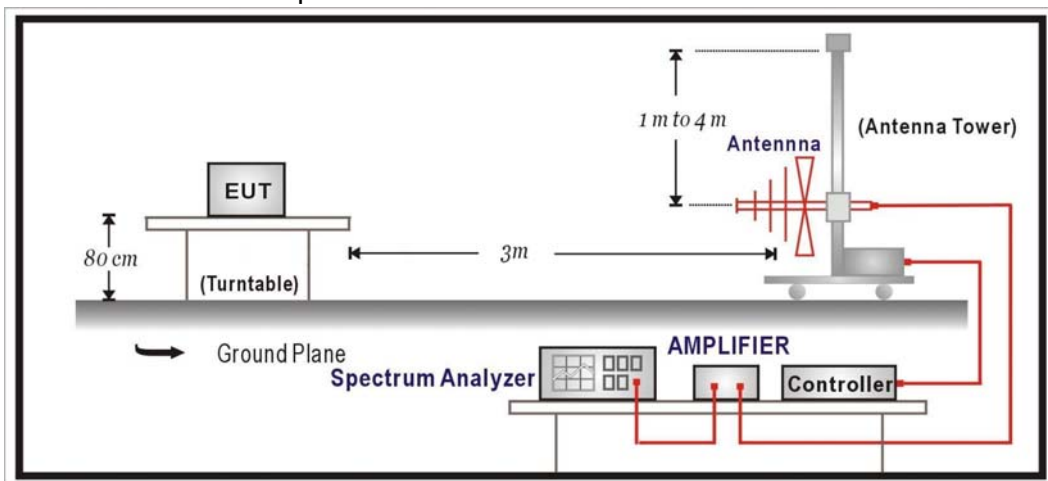

Above 1GHz Test Setup:

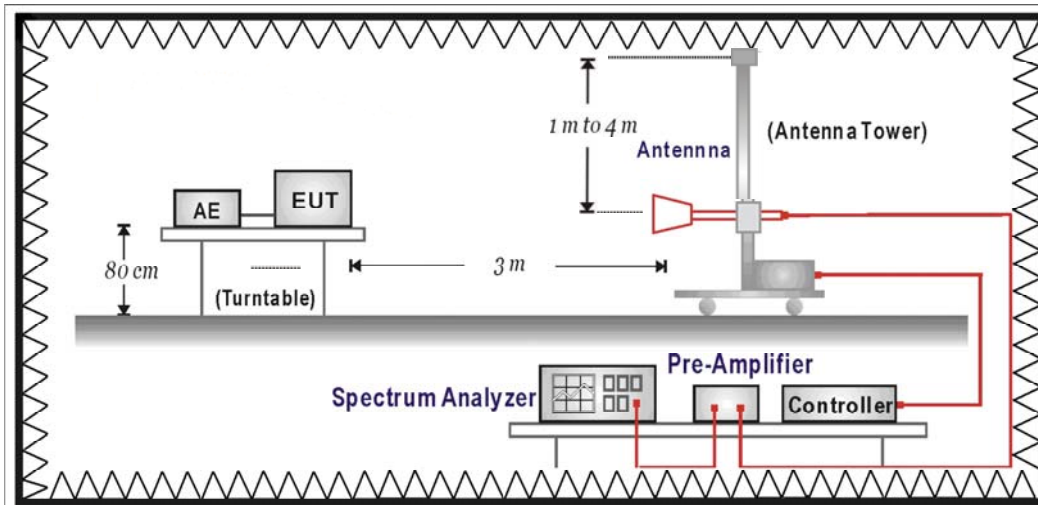

4.3. Limits

Emissions radiated outside of the specified frequency bands, except for harmonics, shall be attenuated by at least 20dB below the level of the fundamental or to the general radiated emission limits in paragraph 15.209, whichever is the lesser attenuation.

FCC Part 15 Subpart C Paragraph 15.209 Limits		
Frequency MHz	dBuV/m	dBuV/m
30-88	100	40
88-216	150	43.5
216-960	200	46
Above 960	500	54

Remarks: E field strength (dBuV/m) = 20 log E field strength (uV/m)

4.4. Test Procedure

The EUT was setup according to ANSI C63.4: 2009 and tested according to DTS test procedure of Oct 2002 KDB558074 for compliance to FCC 47CFR 15.247 requirements. The EUT and its simulators are placed on a turn table which is 0.8 meter above ground. The turn table can rotate 360 degrees to determine the position of the maximum emission level. The antenna can move up and down between 1 meter and 4 meters to find out the maximum emission level.

Both horizontal and vertical polarization of the antenna are set on measurement. In order to find the maximum emission, all of the interface cables must be manipulated according to ANSI C63.4: 2009 on radiated measurement.

On any frequency or frequencies below or equal to 1000 MHz, the limits shown are based on measuring equipment employing a quasi-peak detector function and on any frequency or frequencies above 1000 MHz the radiated limits shown are based upon the use of measurement instrumentation employing an average detector function. When average radiated emission measurement are included emission measurement below 1000 MHz, there also is a limit on the radio frequency emissions, as measured using instrumentation with a peak detector function, corresponding to 20 dB above the maximum permitted average limit. The bandwidth below 1GHz setting on the field strength meter is 120 kHz and above 1GHz is 1MHz.

4.5. Test Specification

According to FCC Part 15 Subpart C Paragraph 15.247: 2010

4.6. Uncertainty

The measurement uncertainty

30MHz~1GHz as ±3.43dB

1GHz~26.5Ghz as ±3.65dB

4.7. Test Result

30MHz-1GHz Spurious

Site : CB1	Time : 2011/10/17 - 10:22
Limit : FCC_CLASS_B_03M_QP	Margin : 6
Probe : EFS_30-1G-1_0901 - HORIZONTAL	Power : AC120V/60Hz
EUT : Wireless N Day/Night Internet Camera	Note : Mode 1: Transmit_2437MHz-802.11b

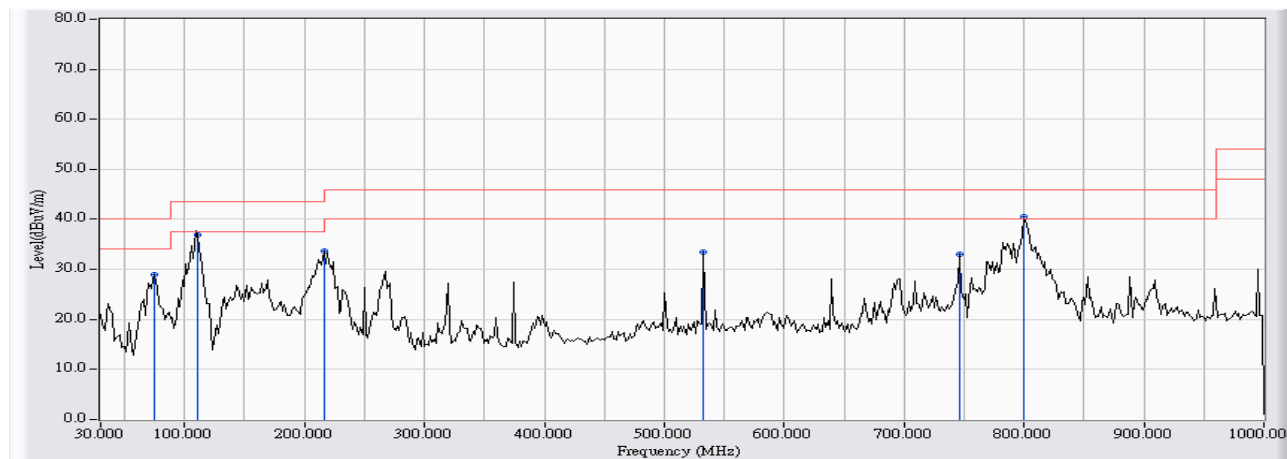

	Frequency (MHz)	Correct Factor (dB)	Reading Level (dBuV)	Measure Level (dBuV/m)	Margin (dB)	Limit (dBuV/m)	Detector Type
1	75.267	-17.377	46.231	28.854	-11.146	40.000	PEAK
2	110.833	-12.584	49.495	36.911	-6.589	43.500	PEAK
3	215.917	-13.554	47.284	33.731	-9.769	43.500	PEAK
4	532.783	-4.952	38.356	33.404	-12.596	46.000	PEAK
5	746.183	-3.339	36.450	33.112	-12.888	46.000	PEAK
6	* 799.533	-2.655	43.091	40.436	-5.564	46.000	PEAK

Note:

1. All Reading Levels are Quasi-Peak value.
2. “ * ”, means this data is the worst emission level.
3. Measurement Level = Reading Level + Correct Factor.

Site : CB1	Time : 2011/10/17 - 10:26
Limit : FCC_CLASS_B_03M_QP	Margin : 6
Probe : EFS_30-1G-1_0901 - VERTICAL	Power : AC120V/60Hz
EUT : Wireless N Day/Night Internet Camera	Note : Mode 1: Transmit_2437MHz-802.11b

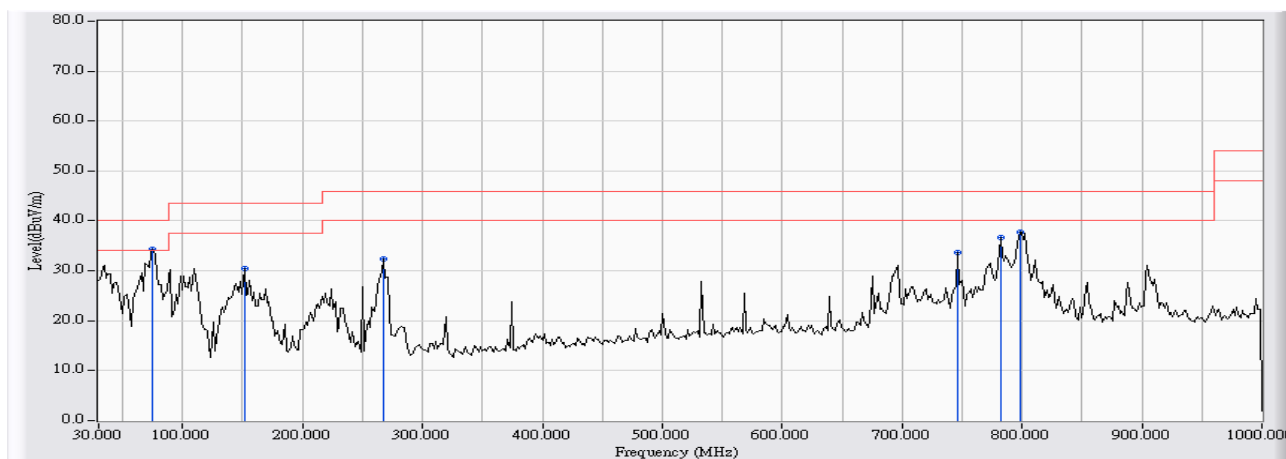

		Frequency (MHz)	Correct Factor (dB)	Reading Level (dBuV)	Measure Level (dBuV/m)	Margin (dB)	Limit (dBuV/m)	Detector Type
1	*	75.267	-17.377	51.608	34.231	-5.769	40.000	PEAK
2		151.250	-13.510	44.043	30.533	-12.967	43.500	PEAK
3		267.650	-10.785	43.238	32.452	-13.548	46.000	PEAK
4		746.183	-3.339	37.077	33.739	-12.261	46.000	PEAK
5		781.750	-2.884	39.577	36.694	-9.306	46.000	PEAK
6		797.917	-2.676	40.514	37.838	-8.162	46.000	PEAK

Note:

1. All Reading Levels are Quasi-Peak value.
2. “ * ”, means this data is the worst emission level.
3. Measurement Level = Reading Level + Correct Factor.

Site : CB1	Time : 2011/10/17 - 11:10
Limit : FCC_CLASS_B_03M_QP	Margin : 6
Probe : EFS_30-1G-1_0901 - HORIZONTAL	Power : AC120V/60Hz
EUT : Wireless N Day/Night Internet Camera	Note : Mode 1: Transmit_2437MHz_802.11g

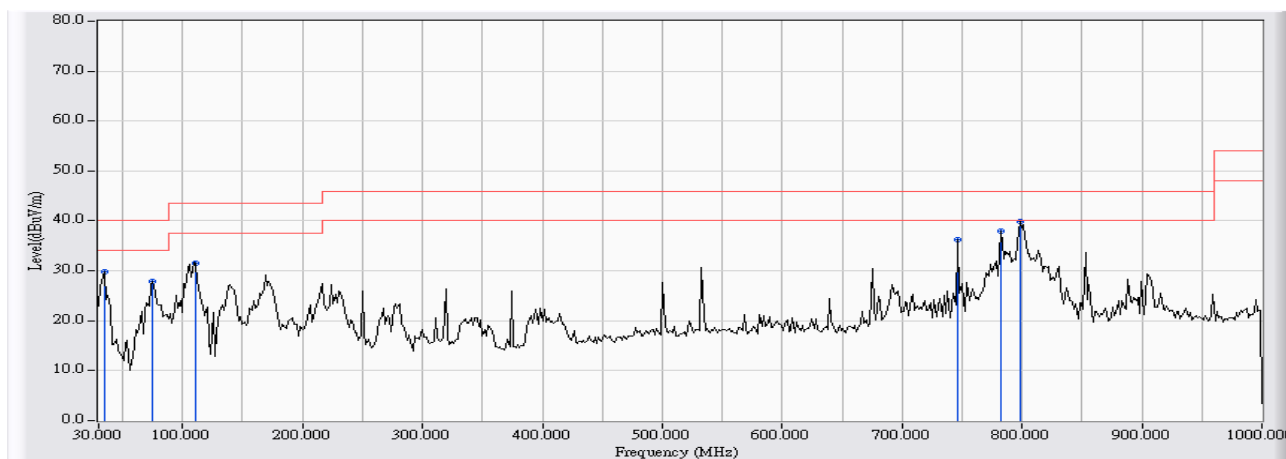

	Frequency (MHz)	Correct Factor (dB)	Reading Level (dBuV)	Measure Level (dBuV/m)	Margin (dB)	Limit (dBuV/m)	Detector Type
1	34.850	-10.798	40.654	29.856	-10.144	40.000	PEAK
2	75.267	-17.377	45.360	27.983	-12.017	40.000	PEAK
3	110.833	-12.584	44.177	31.593	-11.907	43.500	PEAK
4	746.183	-3.339	39.575	36.237	-9.763	46.000	PEAK
5	781.750	-2.884	40.900	38.017	-7.983	46.000	PEAK
6	* 797.917	-2.676	42.579	39.903	-6.097	46.000	PEAK

Note:

1. All Reading Levels are Quasi-Peak value.
2. “ * ”, means this data is the worst emission level.
3. Measurement Level = Reading Level + Correct Factor.

Site : CB1	Time : 2011/10/17 - 11:14
Limit : FCC_CLASS_B_03M_QP	Margin : 6
Probe : EFS_30-1G-1_0901 - VERTICAL	Power : AC120V/60Hz
EUT : Wireless N Day/Night Internet Camera	Note : Mode 1: Transmit_2437MHz_802.11g

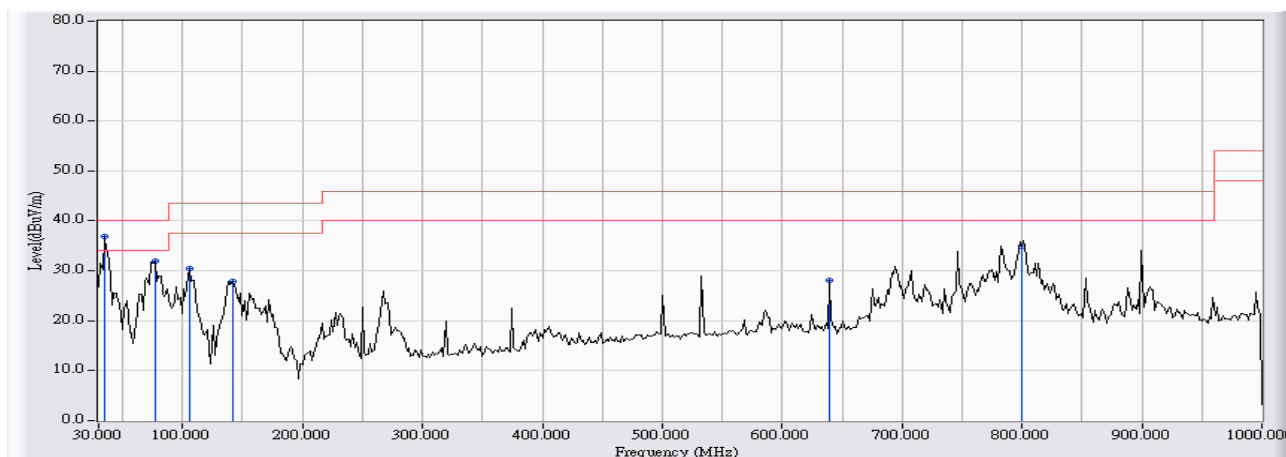

		Frequency (MHz)	Correct Factor (dB)	Reading Level (dBuV)	Measure Level (dBuV/m)	Margin (dB)	Limit (dBuV/m)	Detector Type
1	*	34.850	-10.798	47.792	36.994	-3.006	40.000	PEAK
2		76.883	-17.261	49.139	31.878	-8.122	40.000	PEAK
3		105.983	-13.004	43.418	30.414	-13.086	43.500	PEAK
4		141.550	-13.023	40.917	27.893	-15.607	43.500	PEAK
5		639.483	-4.135	32.322	28.187	-17.813	46.000	PEAK
6		799.533	-2.655	37.673	35.018	-10.982	46.000	PEAK

Note:

1. All Reading Levels are Quasi-Peak value.
2. “ * ”, means this data is the worst emission level.
3. Measurement Level = Reading Level + Correct Factor.

Site : CB1	Time : 2011/10/17 - 11:43
Limit : FCC_CLASS_B_03M_QP	Margin : 6
Probe : EFS_30-1G-1_0901 - HORIZONTAL	Power : AC120V/60Hz
EUT : Wireless N Day/Night Internet Camera	Note : Mode 1: Transmit_2437MHz_802.11n(20MHz)

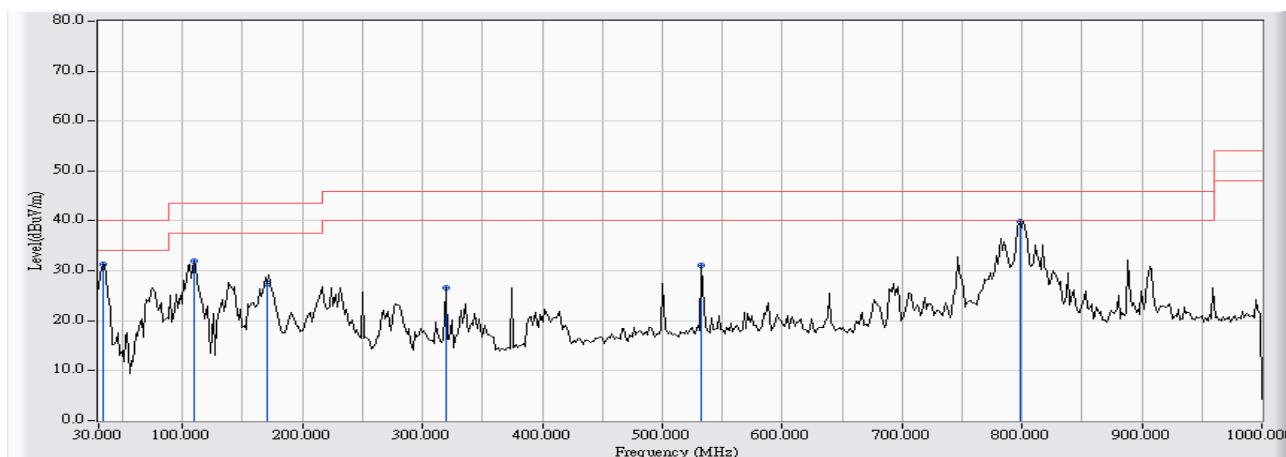

	Frequency (MHz)	Correct Factor (dB)	Reading Level (dBuV)	Measure Level (dBuV/m)	Margin (dB)	Limit (dBuV/m)	Detector Type
1	33.233	-10.505	41.812	31.307	-8.693	40.000	PEAK
2	109.217	-12.724	44.706	31.982	-11.518	43.500	PEAK
3	170.650	-14.349	41.763	27.413	-16.087	43.500	PEAK
4	319.383	-9.707	36.273	26.566	-19.434	46.000	PEAK
5	532.783	-4.952	36.006	31.054	-14.946	46.000	PEAK
6	* 797.917	-2.676	42.635	39.959	-6.041	46.000	PEAK

Note:

1. All Reading Levels are Quasi-Peak value.
2. “ * ”, means this data is the worst emission level.
3. Measurement Level = Reading Level + Correct Factor.

Site : CB1	Time : 2011/10/17 - 11:48
Limit : FCC_CLASS_B_03M_QP	Margin : 6
Probe : EFS_30-1G-1_0901 - VERTICAL	Power : AC120V/60Hz
EUT : Wireless N Day/Night Internet Camera I	Note : Mode 1: Transmit_2437MHz_802.11n(20MHz)

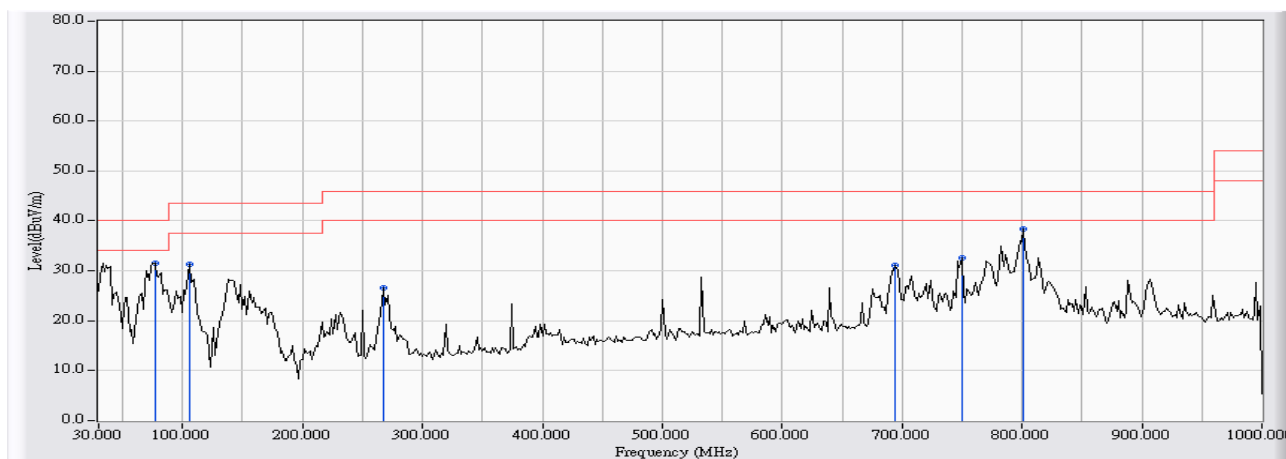

	Frequency (MHz)	Correct Factor (dB)	Reading Level (dBuV)	Measure Level (dBuV/m)	Margin (dB)	Limit (dBuV/m)	Detector Type
1	76.883	-17.261	48.757	31.496	-8.504	40.000	PEAK
2	105.983	-13.004	44.285	31.281	-12.219	43.500	PEAK
3	267.650	-10.785	37.368	26.582	-19.418	46.000	PEAK
4	694.450	-3.953	35.109	31.156	-14.844	46.000	PEAK
5	749.417	-3.297	35.831	32.535	-13.465	46.000	PEAK
6	* 801.150	-2.642	41.049	38.407	-7.593	46.000	PEAK

Note:

1. All Reading Levels are Quasi-Peak value.
2. “ * ”, means this data is the worst emission level.
3. Measurement Level = Reading Level + Correct Factor.

Site : CB1	Time : 2011/10/17 - 13:19
Limit : FCC_CLASS_B_03M_QP	Margin : 6
Probe : EFS_30-1G-1_0901 - HORIZONTAL	Power : AC120V/60Hz
EUT : Wireless N Day/Night Internet Camera	Note : Mode 1: Transmit_2437MHz_802.11n(40MHz)

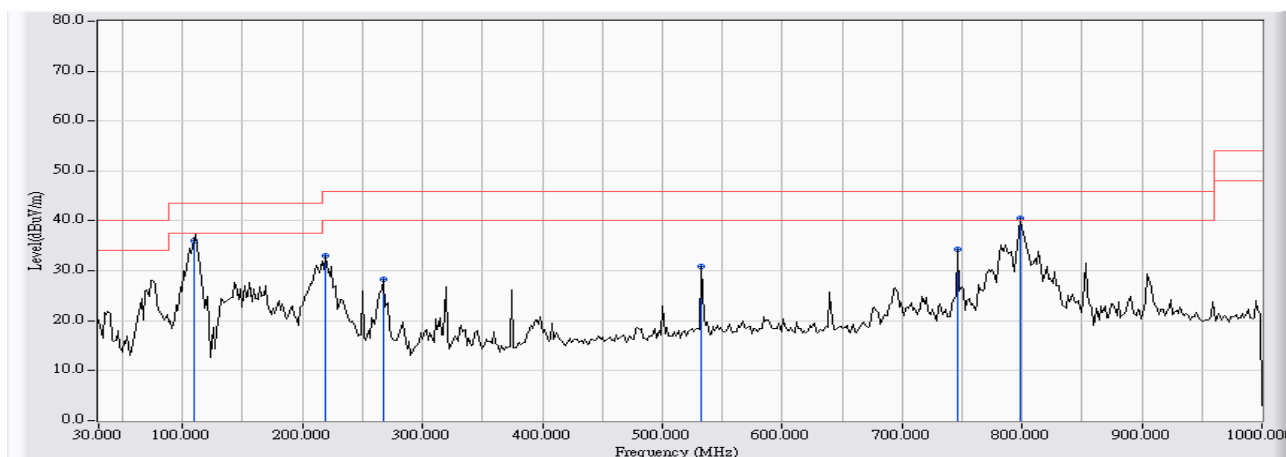

	Frequency (MHz)	Correct Factor (dB)	Reading Level (dBuV)	Measure Level (dBuV/m)	Margin (dB)	Limit (dBuV/m)	Detector Type
1	109.217	-12.724	48.700	35.976	-7.524	43.500	PEAK
2	219.150	-13.317	46.346	33.029	-12.971	46.000	PEAK
3	267.650	-10.785	38.991	28.205	-17.795	46.000	PEAK
4	532.783	-4.952	35.894	30.942	-15.058	46.000	PEAK
5	746.183	-3.339	37.685	34.347	-11.653	46.000	PEAK
6	* 797.917	-2.676	43.109	40.433	-5.567	46.000	PEAK

Note:

1. All Reading Levels are Quasi-Peak value.
2. “ * ”, means this data is the worst emission level.
3. Measurement Level = Reading Level + Correct Factor.

Site : CB1	Time : 2011/10/17 - 21:22
Limit : FCC_CLASS_B_03M_QP	Margin : 6
Probe : EFS_30-1G-1_0901 - VERTICAL	Power : AC120V/60Hz
EUT : Wireless N Day/Night Internet Camera	Note : Mode 1: Transmit_2437MHz_802.11n(40MHz)

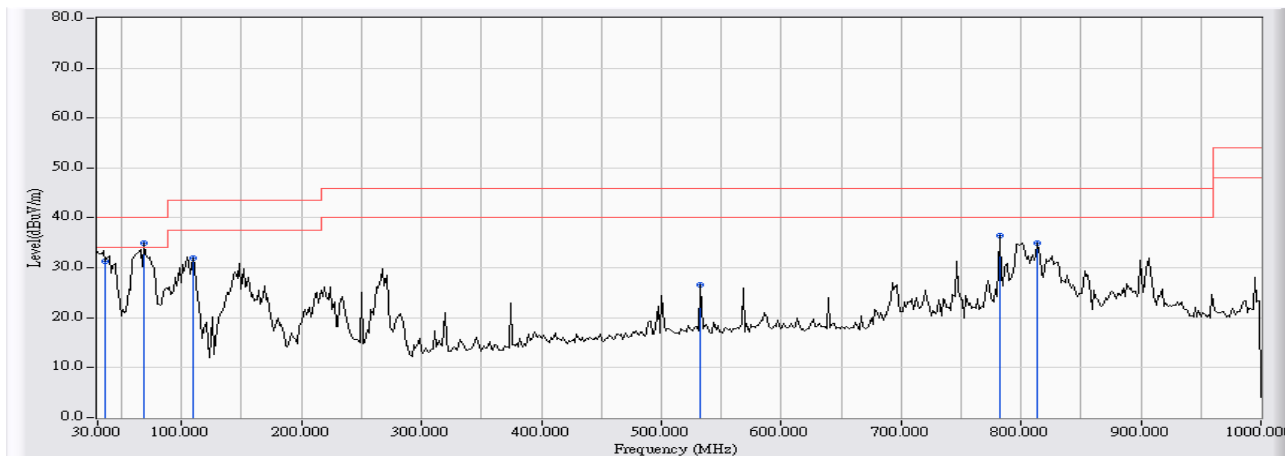

	Frequency (MHz)	Correct Factor (dB)	Reading Level (dBuV)	Measure Level (dBuV/m)	Margin (dB)	Limit (dBuV/m)	Detector Type
1	36.467	-11.275	42.562	31.287	-8.713	40.000	PEAK
2	* 68.800	-17.759	52.779	35.019	-4.981	40.000	PEAK
3	109.217	-12.724	44.612	31.888	-11.612	43.500	PEAK
4	532.783	-4.952	31.459	26.507	-19.493	46.000	PEAK
5	781.750	-2.884	39.312	36.429	-9.571	46.000	PEAK
6	814.083	-2.557	37.413	34.855	-11.145	46.000	PEAK

Note:

1. All Reading Levels are Quasi-Peak value.
2. “ * ”, means this data is the worst emission level.
3. Measurement Level = Reading Level + Correct Factor.

Harmonic & Spurious:

Site : CB1	Time : 2011/09/30 - 16:18
Limit : FCC_SpartC_15.247_H_03M_PK	Margin : 6
Probe : EFS_1-18G-1_0901 - HORIZONTAL	Power : AC120V/60Hz
EUT : Wireless N Day/Night Internet Camera	Note : Mode 1: Transmit_2412MHz_802.11_b

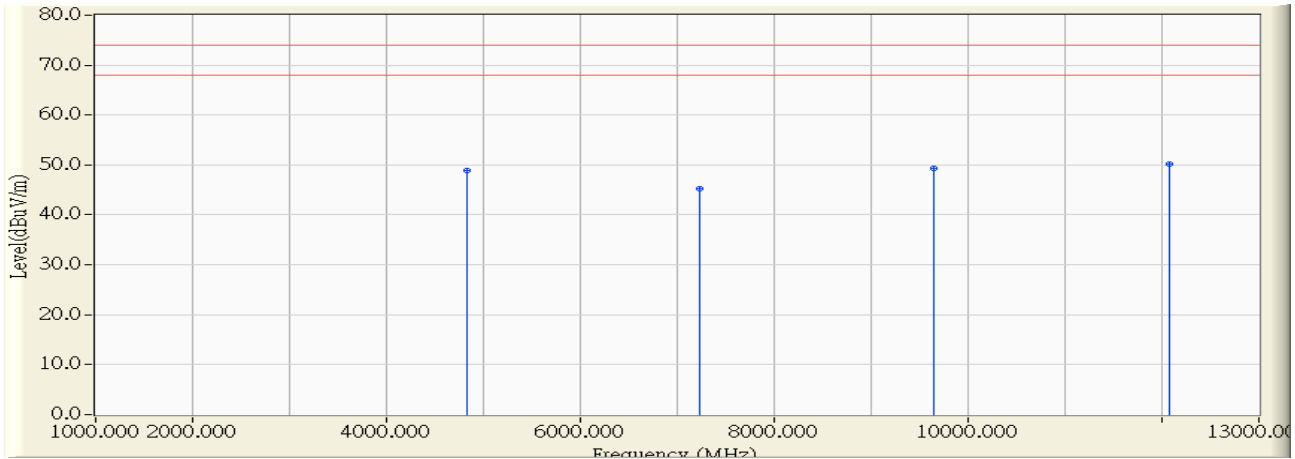

	Frequency (MHz)	Correct Factor (dB)	Reading Level (dBuV)	Measure Level (dBuV/m)	Margin (dB)	Peak Limit (dBuV/m)	Average Limit (dBuV/m)	Detector Type
1	4824.000	-0.803	49.670	48.867	-25.133	74.000	54.00	PEAK
2	7236.000	5.497	39.700	45.196	-28.804	74.000	54.00	PEAK
3	9648.000	9.230	40.100	49.331	-24.669	74.000	54.00	PEAK
4	* 12070.000	11.522	38.690	50.212	-23.788	74.000	54.00	PEAK

Note:

1. All readings above 1GHz are performed with peak and/or average measurements as necessary.
2. Peak measurements: RBW = 1MHz, VBW = 3 MHz, Sweep: Auto.
3. Average measurements: RBW = 1MHz, VBW = 10 Hz, Sweep: Auto.
4. “ * ”, means this data is the worst emission level.
5. Measurement Level = Reading Level + Correct Factor.
6. The average measurement was not performed when the peak measured data under the limit of average detection.
7. The Emission above 13GHz were not included is because their levels are too low.

Site : CB1	Time : 2011/09/30 - 16:23
Limit : FCC_SpartC_15.247_H_03M_PK	Margin : 6
Probe : EFS_1-18G-1_0901 - VERTICAL	Power : AC120V/60Hz
EUT : Wireless N Day/Night Internet Camera	Note : Mode 1: Transmit_2412MHz_802.11_b

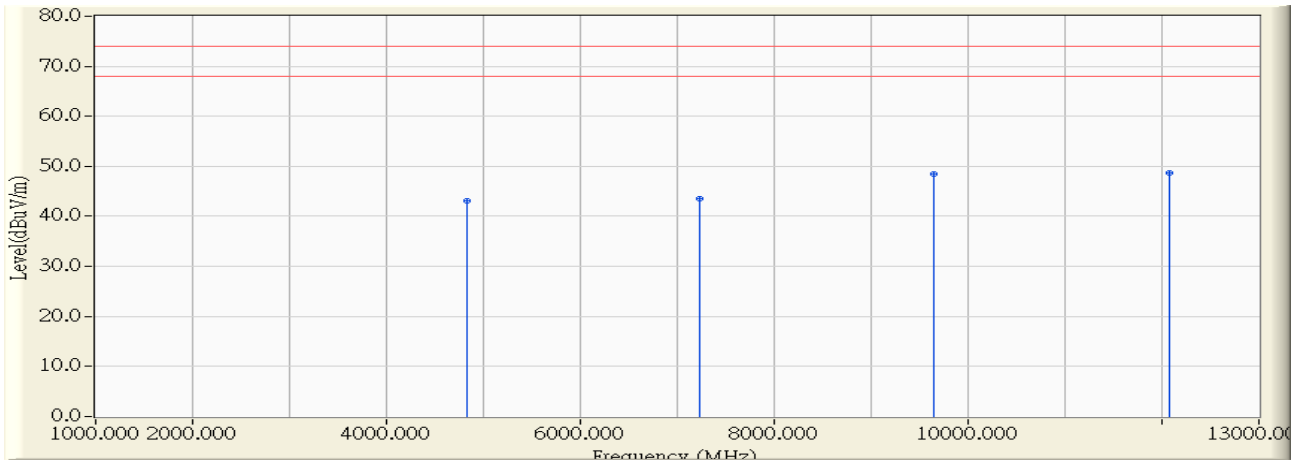

	Frequency (MHz)	Correct Factor (dB)	Reading Level (dBuV)	Measure Level (dBuV/m)	Margin (dB)	Peak Limit (dBuV/m)	Average Limit (dBuV/m)	Detector Type
1	4824.000	-0.803	43.850	43.047	-30.953	74.000	54.00	PEAK
2	7236.000	5.497	38.050	43.546	-30.454	74.000	54.00	PEAK
3	9648.000	9.230	39.230	48.461	-25.539	74.000	54.00	PEAK
4	* 12070.000	11.522	37.090	48.612	-25.388	74.000	54.00	PEAK

Note:

1. All readings above 1GHz are performed with peak and/or average measurements as necessary.
2. Peak measurements: RBW = 1MHz, VBW = 3 MHz, Sweep: Auto.
3. Average measurements: RBW = 1MHz, VBW = 10 Hz, Sweep: Auto.
4. “ * ”, means this data is the worst emission level.
5. Measurement Level = Reading Level + Correct Factor.
6. The average measurement was not performed when the peak measured data under the limit of average detection.
7. The Emission above 13GHz were not included is because their levels are too low.

Site : CB1	Time : 2011/09/30 - 16:28
Limit : FCC_SpartC_15.247_H_03M_PK	Margin : 6
Probe : EFS_1-18G-1_0901 - HORIZONTAL	Power : AC120V/60Hz
EUT : Wireless N Day/Night Internet Camera	Note : Mode 1: Transmit_2437MHz_802.11_b

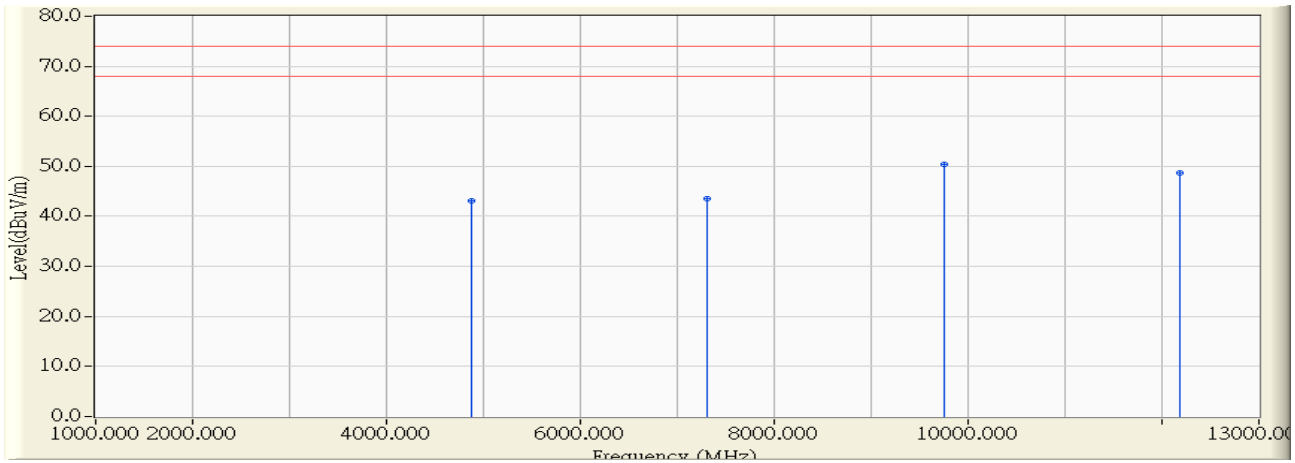

	Frequency (MHz)	Correct Factor (dB)	Reading Level (dBuV)	Measure Level (dBuV/m)	Margin (dB)	Peak Limit (dBuV/m)	Average Limit (dBuV/m)	Detector Type
1	4872.000	-0.677	43.880	43.203	-30.797	74.000	54.00	PEAK
2	7311.000	5.678	37.830	43.507	-30.493	74.000	54.00	PEAK
3	* 9748.000	9.955	40.510	50.465	-23.535	74.000	54.00	PEAK
4	12185.000	11.481	37.210	48.691	-25.309	74.000	54.00	PEAK

Note:

1. All readings above 1GHz are performed with peak and/or average measurements as necessary.
2. Peak measurements: RBW = 1MHz, VBW = 3 MHz, Sweep: Auto.
3. Average measurements: RBW = 1MHz, VBW = 10 Hz, Sweep: Auto.
4. “ * ”, means this data is the worst emission level.
5. Measurement Level = Reading Level + Correct Factor.
6. The average measurement was not performed when the peak measured data under the limit of average detection.
7. The Emission above 13GHz were not included is because their levels are too low.

Site : CB1	Time : 2011/09/30 - 16:37
Limit : FCC_SpartC_15.247_H_03M_PK	Margin : 6
Probe : EFS_1-18G-1_0901 - VERTICAL	Power : AC120V/60Hz
EUT : Wireless N Day/Night Internet Camera	Note : Mode 1: Transmit_2437MHz_802.11_b

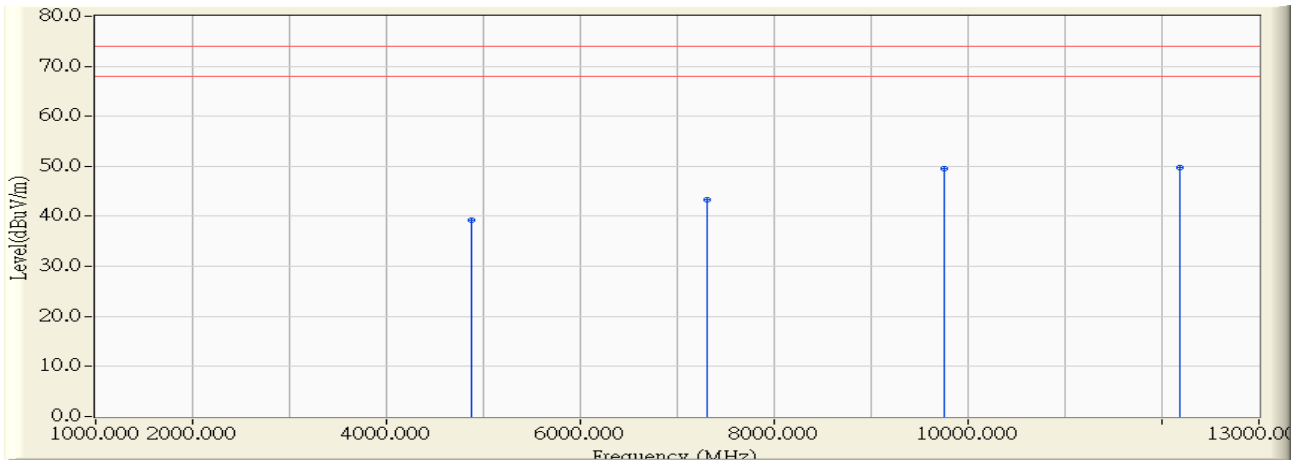

	Frequency (MHz)	Correct Factor (dB)	Reading Level (dBuV)	Measure Level (dBuV/m)	Margin (dB)	Peak Limit (dBuV/m)	Average Limit (dBuV/m)	Detector Type
1	4874.000	-0.672	39.920	39.248	-34.752	74.000	54.00	PEAK
2	7311.000	5.678	37.660	43.337	-30.663	74.000	54.00	PEAK
3	9748.000	9.955	39.630	49.585	-24.415	74.000	54.00	PEAK
4	* 12185.000	11.481	38.290	49.771	-24.229	74.000	54.00	PEAK

Note:

1. All readings above 1GHz are performed with peak and/or average measurements as necessary.
2. Peak measurements: RBW = 1MHz, VBW = 3 MHz, Sweep: Auto.
3. Average measurements: RBW = 1MHz, VBW = 10 Hz, Sweep: Auto.
4. “ * ”, means this data is the worst emission level.
5. Measurement Level = Reading Level + Correct Factor.
6. The average measurement was not performed when the peak measured data under the limit of average detection.
7. The Emission above 13GHz were not included is because their levels are too low.

Site : CB1	Time : 2011/09/30 - 16:43
Limit : FCC_SpartC_15.247_H_03M_PK	Margin : 6
Probe : EFS_1-18G-1_0901 - HORIZONTAL	Power : AC120V/60Hz
EUT : Wireless N Day/Night Internet Camera	Note : Mode 1: Transmit_2462MHz_802.11_b

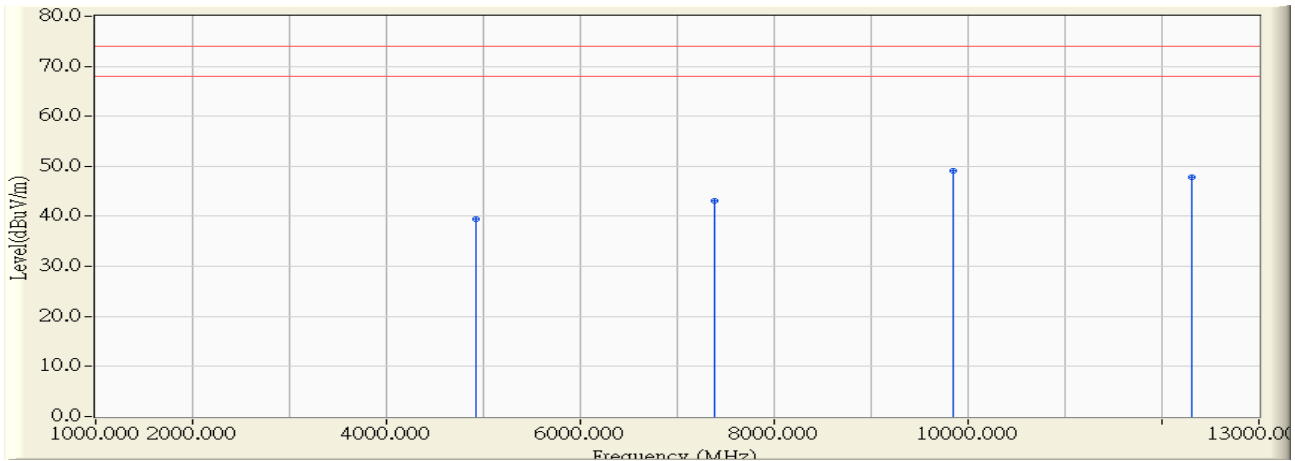

	Frequency (MHz)	Correct Factor (dB)	Reading Level (dBuV)	Measure Level (dBuV/m)	Margin (dB)	Peak Limit (dBuV/m)	Average Limit (dBuV/m)	Detector Type
1	4924.000	-0.541	39.960	39.419	-34.581	74.000	54.00	PEAK
2	7386.000	5.859	37.330	43.188	-30.812	74.000	54.00	PEAK
3	* 9848.000	10.680	38.480	49.160	-24.840	74.000	54.00	PEAK
4	12310.000	11.437	36.480	47.917	-26.083	74.000	54.00	PEAK

Note:

1. All readings above 1GHz are performed with peak and/or average measurements as necessary.
2. Peak measurements: RBW = 1MHz, VBW = 3 MHz, Sweep: Auto.
3. Average measurements: RBW = 1MHz, VBW = 10 Hz, Sweep: Auto.
4. “ * ”, means this data is the worst emission level.
5. Measurement Level = Reading Level + Correct Factor.
6. The average measurement was not performed when the peak measured data under the limit of average detection.
7. The Emission above 13GHz were not included is because their levels are too low.

Site : CB1	Time : 2011/09/30 - 16:47
Limit : FCC_SpartC_15.247_H_03M_PK	Margin : 6
Probe : EFS_1-18G-1_0901 - VERTICAL	Power : AC120V/60Hz
EUT : Wireless N Day/Night Internet Camera	Note : Mode 1: Transmit_2462MHz_802.11_b

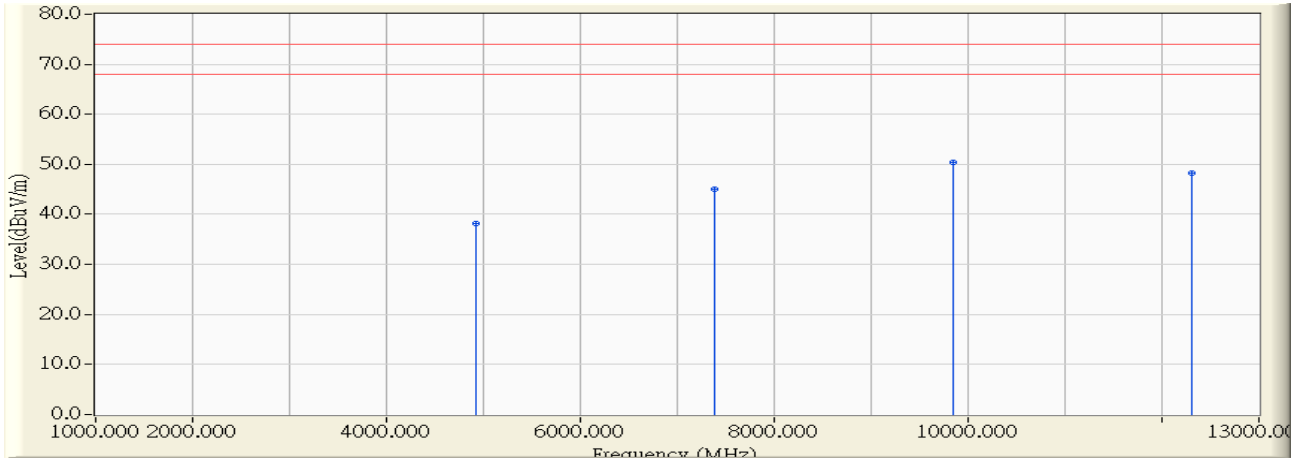

	Frequency (MHz)	Correct Factor (dB)	Reading Level (dBuV)	Measure Level (dBuV/m)	Margin (dB)	Peak Limit (dBuV/m)	Average Limit (dBuV/m)	Detector Type
1	4924.000	-0.541	38.620	38.079	-35.921	74.000	54.00	PEAK
2	7386.000	5.859	39.130	44.988	-29.012	74.000	54.00	PEAK
3	* 9848.000	10.680	39.630	50.310	-23.690	74.000	54.00	PEAK
4	12310.000	11.437	36.920	48.357	-25.643	74.000	54.00	PEAK

Note:

1. All readings above 1GHz are performed with peak and/or average measurements as necessary.
2. Peak measurements: RBW = 1MHz, VBW = 3 MHz, Sweep: Auto.
3. Average measurements: RBW = 1MHz, VBW = 10 Hz, Sweep: Auto.
4. “ * ”, means this data is the worst emission level.
5. Measurement Level = Reading Level + Correct Factor.
6. The average measurement was not performed when the peak measured data under the limit of average detection.
7. The Emission above 13GHz were not included is because their levels are too low.

Site : CB1	Time : 2011/09/30 - 16:52
Limit : FCC_SpartC_15.247_H_03M_PK	Margin : 6
Probe : EFS_1-18G-1_0901 - HORIZONTAL	Power : AC120V/60Hz
EUT : Wireless N Day/Night Internet Camera	Note : Mode 1: Transmit_2412MHz_802.11_g

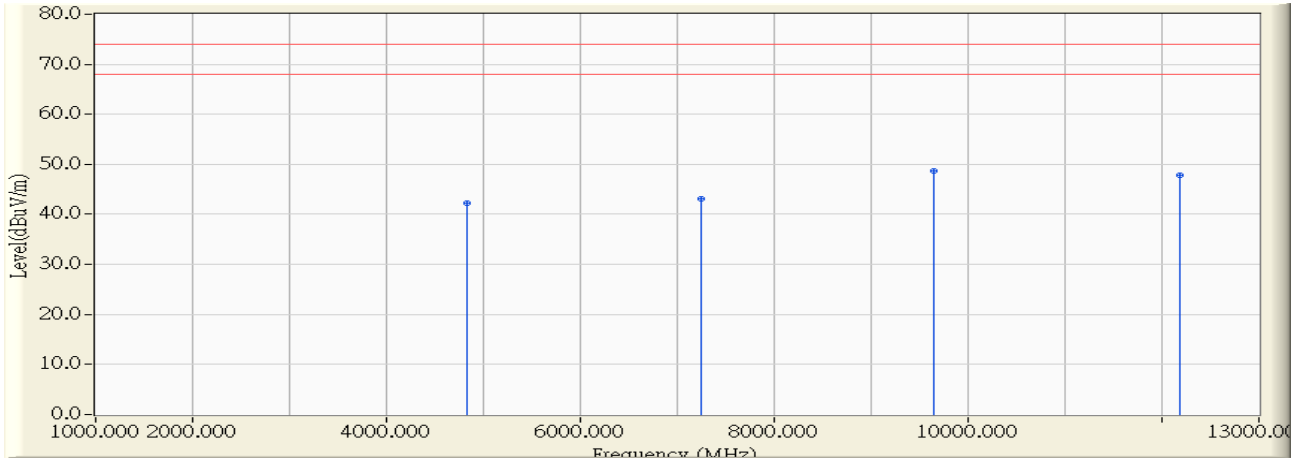

	Frequency (MHz)	Correct Factor (dB)	Reading Level (dBuV)	Measure Level (dBuV/m)	Margin (dB)	Peak Limit (dBuV/m)	Average Limit (dBuV/m)	Detector Type
1	4824.000	-0.803	43.130	42.327	-31.673	74.000	54.00	PEAK
2	7239.000	5.504	37.700	43.204	-30.796	74.000	54.00	PEAK
3	* 9648.000	9.230	39.550	48.781	-25.219	74.000	54.00	PEAK
4	12185.000	11.481	36.380	47.861	-26.139	74.000	54.00	PEAK

Note:

1. All readings above 1GHz are performed with peak and/or average measurements as necessary.
2. Peak measurements: RBW = 1MHz, VBW = 3 MHz, Sweep: Auto.
3. Average measurements: RBW = 1MHz, VBW = 10 Hz, Sweep: Auto.
4. “ * ”, means this data is the worst emission level.
5. Measurement Level = Reading Level + Correct Factor.
6. The average measurement was not performed when the peak measured data under the limit of average detection.
7. The Emission above 13GHz were not included is because their levels are too low.

Site : CB1	Time : 2011/09/30 - 16:56
Limit : FCC_SpartC_15.247_H_03M_PK	Margin : 6
Probe : EFS_1-18G-1_0901 - VERTICAL	Power : AC120V/60Hz
EUT : Wireless N Day/Night Internet Camera	Note : Mode 1: Transmit_2412MHz_802.11_g

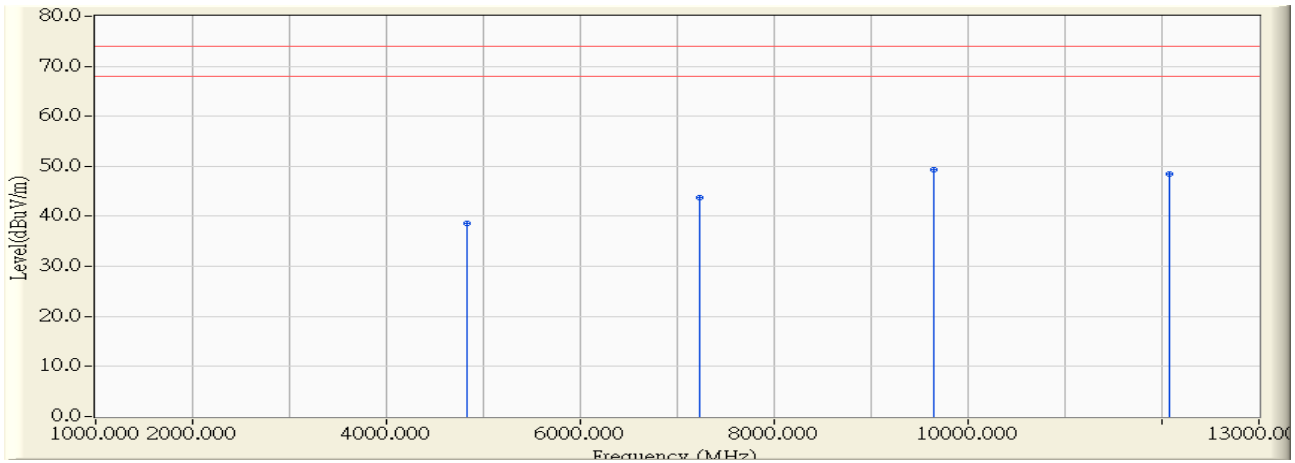

	Frequency (MHz)	Correct Factor (dB)	Reading Level (dBuV)	Measure Level (dBuV/m)	Margin (dB)	Peak Limit (dBuV/m)	Average Limit (dBuV/m)	Detector Type
1	4824.000	-0.803	39.350	38.547	-35.453	74.000	54.00	PEAK
2	7236.000	5.497	38.250	43.746	-30.254	74.000	54.00	PEAK
3	* 9648.000	9.230	40.020	49.251	-24.749	74.000	54.00	PEAK
4	12070.000	11.522	36.940	48.462	-25.538	74.000	54.00	PEAK

Note:

1. All readings above 1GHz are performed with peak and/or average measurements as necessary.
2. Peak measurements: RBW = 1MHz, VBW = 3 MHz, Sweep: Auto.
3. Average measurements: RBW = 1MHz, VBW = 10 Hz, Sweep: Auto.
4. “ * ”, means this data is the worst emission level.
5. Measurement Level = Reading Level + Correct Factor.
6. The average measurement was not performed when the peak measured data under the limit of average detection.
7. The Emission above 13GHz were not included is because their levels are too low.

Site : CB1	Time : 2011/09/30 - 17:02
Limit : FCC_SpartC_15.247_H_03M_PK	Margin : 6
Probe : EFS_1-18G-1_0901 - HORIZONTAL	Power : AC120V/60Hz
EUT : Wireless N Day/Night Internet Camera	Note : Mode 1: Transmit_2437MHz_802.11_g

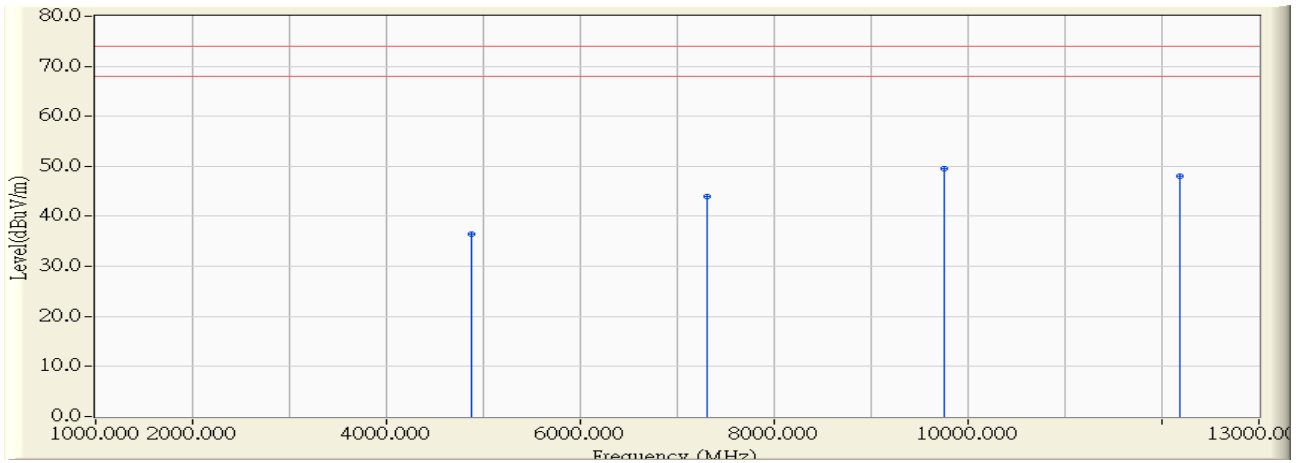

	Frequency (MHz)	Correct Factor (dB)	Reading Level (dBuV)	Measure Level (dBuV/m)	Margin (dB)	Peak Limit (dBuV/m)	Average Limit (dBuV/m)	Detector Type
1	4874.000	-0.672	37.170	36.498	-37.502	74.000	54.00	PEAK
2	7311.000	5.678	38.260	43.937	-30.063	74.000	54.00	PEAK
3	* 9748.000	9.955	39.510	49.465	-24.535	74.000	54.00	PEAK
4	12185.000	11.481	36.640	48.121	-25.879	74.000	54.00	PEAK

Note:

1. All readings above 1GHz are performed with peak and/or average measurements as necessary.
2. Peak measurements: RBW = 1MHz, VBW = 3 MHz, Sweep: Auto.
3. Average measurements: RBW = 1MHz, VBW = 10 Hz, Sweep: Auto.
4. “ * ”, means this data is the worst emission level.
5. Measurement Level = Reading Level + Correct Factor.
6. The average measurement was not performed when the peak measured data under the limit of average detection.
7. The Emission above 13GHz were not included is because their levels are too low.

Site : CB1	Time : 2011/09/30 - 17:06
Limit : FCC_SpartC_15.247_H_03M_PK	Margin : 6
Probe : EFS_1-18G-1_0901 - VERTICAL	Power : AC120V/60Hz
EUT : Wireless N Day/Night Internet Camera	Note : Mode 1: Transmit_2437MHz_802.11_g

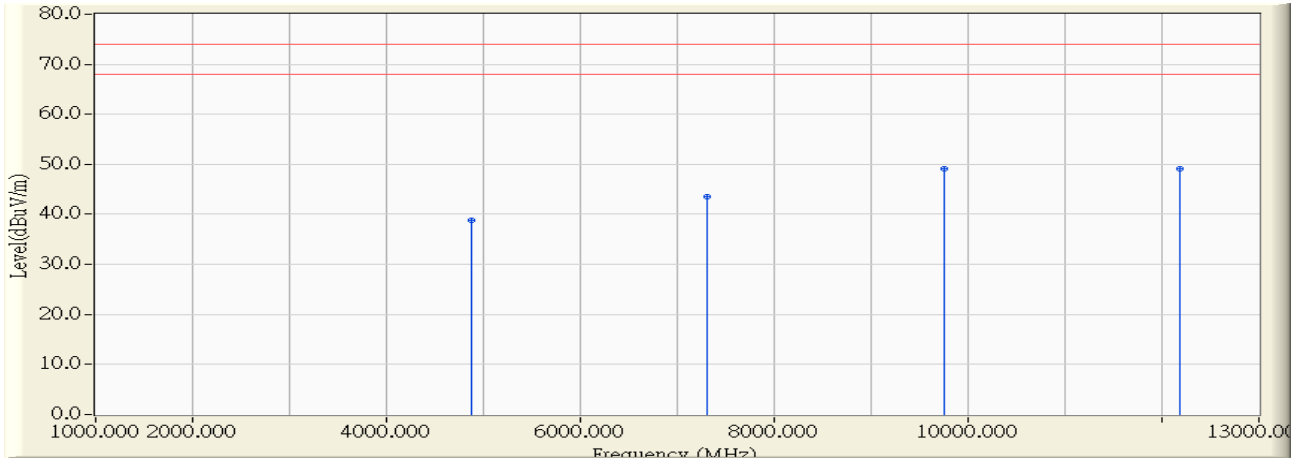

	Frequency (MHz)	Correct Factor (dB)	Reading Level (dBuV)	Measure Level (dBuV/m)	Margin (dB)	Peak Limit (dBuV/m)	Average Limit (dBuV/m)	Detector Type
1	4874.000	-0.672	39.550	38.878	-35.122	74.000	54.00	PEAK
2	7311.000	5.678	37.830	43.507	-30.493	74.000	54.00	PEAK
3	9748.000	9.955	39.150	49.105	-24.895	74.000	54.00	PEAK
4	* 12185.000	11.481	37.700	49.181	-24.819	74.000	54.00	PEAK

Note:

1. All readings above 1GHz are performed with peak and/or average measurements as necessary.
2. Peak measurements: RBW = 1MHz, VBW = 3 MHz, Sweep: Auto.
3. Average measurements: RBW = 1MHz, VBW = 10 Hz, Sweep: Auto.
4. “ * ”, means this data is the worst emission level.
5. Measurement Level = Reading Level + Correct Factor.
6. The average measurement was not performed when the peak measured data under the limit of average detection.
7. The Emission above 13GHz were not included is because their levels are too low.

Site : CB1	Time : 2011/09/30 - 17:10
Limit : FCC_SpartC_15.247_H_03M_PK	Margin : 6
Probe : EFS_1-18G-1_0901 - HORIZONTAL	Power : AC120V/60Hz
EUT : Wireless N Day/Night Internet Camera	Note : Mode 1: Transmit_2462MHz_802.11_g

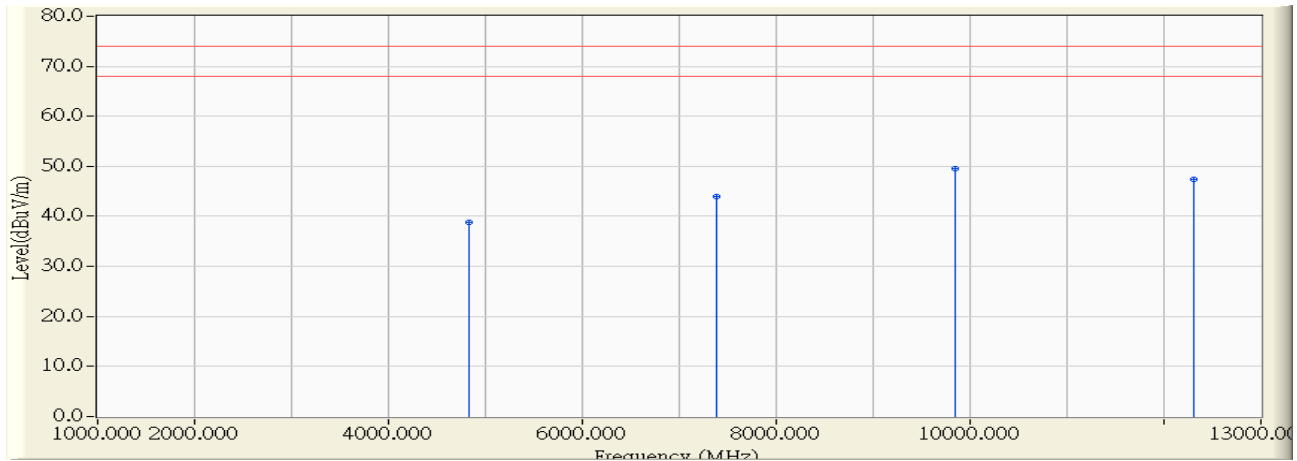

	Frequency (MHz)	Correct Factor (dB)	Reading Level (dBuV)	Measure Level (dBuV/m)	Margin (dB)	Peak Limit (dBuV/m)	Average Limit (dBuV/m)	Detector Type
1	4924.000	-0.803	39.590	38.787	-35.213	74.000	54.00	PEAK
2	7386.000	5.859	38.020	43.878	-30.122	74.000	54.00	PEAK
3	* 9848.000	10.680	38.950	49.630	-24.370	74.000	54.00	PEAK
4	12310.000	11.437	35.990	47.427	-26.573	74.000	54.00	PEAK

Note:

1. All readings above 1GHz are performed with peak and/or average measurements as necessary.
2. Peak measurements: RBW = 1MHz, VBW = 3 MHz, Sweep: Auto.
3. Average measurements: RBW = 1MHz, VBW = 10 Hz, Sweep: Auto.
4. “ * ”, means this data is the worst emission level.
5. Measurement Level = Reading Level + Correct Factor.
6. The average measurement was not performed when the peak measured data under the limit of average detection.
7. The Emission above 13GHz were not included is because their levels are too low.

Site : CB1	Time : 2011/09/30 - 17:14
Limit : FCC_SpartC_15.247_H_03M_PK	Margin : 6
Probe : EFS_1-18G-1_0901 - VERTICAL	Power : AC120V/60Hz
EUT : Wireless N Day/Night Internet Camera	Note : Mode 1: Transmit_2462MHz_802.11_g

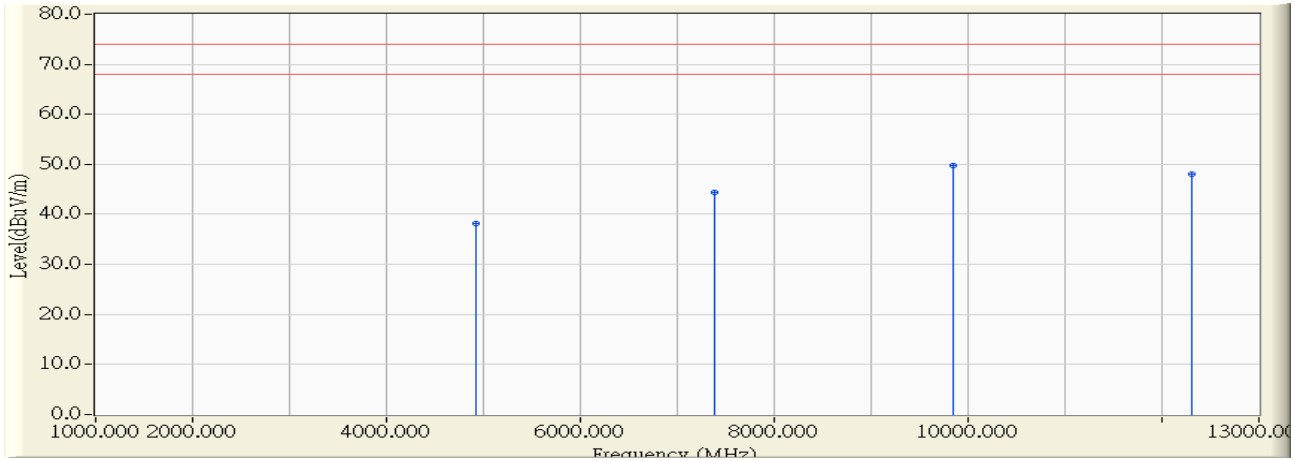

	Frequency (MHz)	Correct Factor (dB)	Reading Level (dBuV)	Measure Level (dBuV/m)	Margin (dB)	Peak Limit (dBuV/m)	Average Limit (dBuV/m)	Detector Type
1	4924.000	-0.541	38.630	38.089	-35.911	74.000	54.00	PEAK
2	7386.000	5.859	38.480	44.338	-29.662	74.000	54.00	PEAK
3	* 9848.000	10.680	39.090	49.770	-24.230	74.000	54.00	PEAK
4	12310.000	11.437	36.650	48.087	-25.913	74.000	54.00	PEAK

Note:

1. All readings above 1GHz are performed with peak and/or average measurements as necessary.
2. Peak measurements: RBW = 1MHz, VBW = 3 MHz, Sweep: Auto.
3. Average measurements: RBW = 1MHz, VBW = 10 Hz, Sweep: Auto.
4. “ * ”, means this data is the worst emission level.
5. Measurement Level = Reading Level + Correct Factor.
6. The average measurement was not performed when the peak measured data under the limit of average detection.
7. The Emission above 13GHz were not included is because their levels are too low.

Site : CB1	Time : 2011/09/30 - 17:19
Limit : FCC_SpartC_15.247_H_03M_PK	Margin : 6
Probe : EFS_1-18G-1_0901 - HORIZONTAL	Power : AC120V/60Hz
EUT : Wireless N Day/Night Internet Camera	Note : Mode 1: Transmit_2412MHz_802.11_n(20MHz)

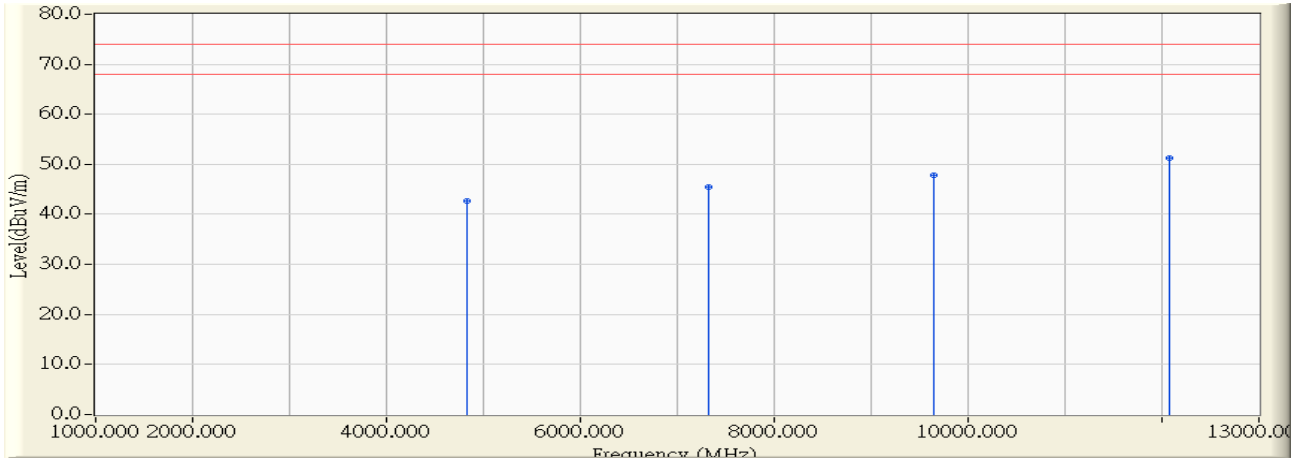

	Frequency (MHz)	Correct Factor (dB)	Reading Level (dBuV)	Measure Level (dBuV/m)	Margin (dB)	Peak Limit (dBuV/m)	Average Limit (dBuV/m)	Detector Type
1	4824.000	-0.803	43.530	42.727	-31.273	74.000	54.00	PEAK
2	7326.000	5.714	39.690	45.404	-28.596	74.000	54.00	PEAK
3	9648.000	9.230	38.510	47.741	-26.259	74.000	54.00	PEAK
4	* 12070.000	11.522	39.670	51.192	-22.808	74.000	54.00	PEAK

Note:

1. All readings above 1GHz are performed with peak and/or average measurements as necessary.
2. Peak measurements: RBW = 1MHz, VBW = 3 MHz, Sweep: Auto.
3. Average measurements: RBW = 1MHz, VBW = 10 Hz, Sweep: Auto.
4. “ * ”, means this data is the worst emission level.
5. Measurement Level = Reading Level + Correct Factor.
6. The average measurement was not performed when the peak measured data under the limit of average detection.
7. The Emission above 13GHz were not included is because their levels are too low.

Site : CB1	Time : 2011/09/30 - 17:21
Limit : FCC_SpartC_15.247_H_03M_PK	Margin : 6
Probe : EFS_1-18G-1_0901 - VERTICAL	Power : AC120V/60Hz
EUT : Wireless N Day/Night Internet Camera	Note : Mode 1: Transmit_2412MHz_802.11_n(20MHz)

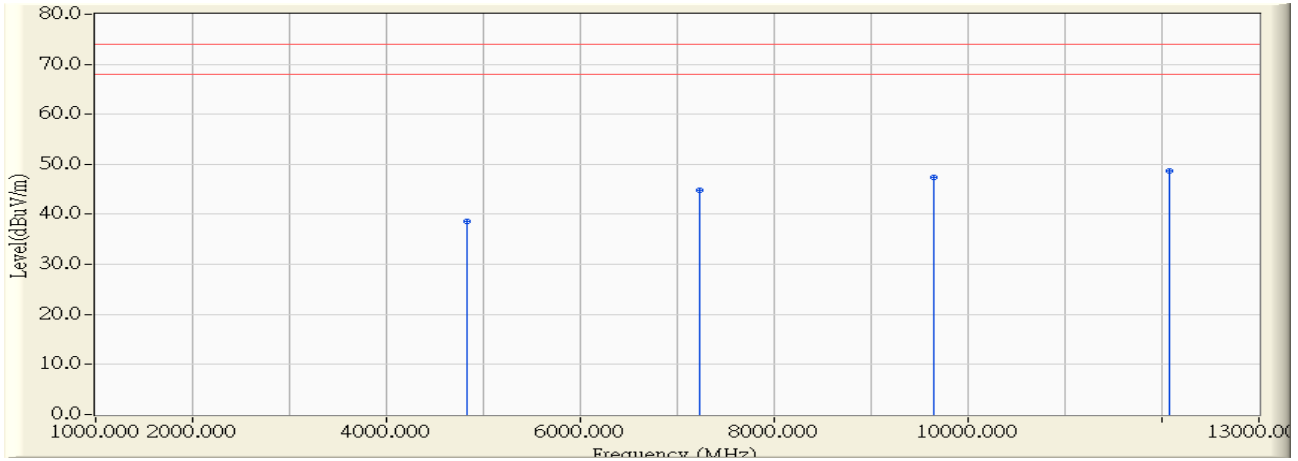

	Frequency (MHz)	Correct Factor (dB)	Reading Level (dBuV)	Measure Level (dBuV/m)	Margin (dB)	Peak Limit (dBuV/m)	Average Limit (dBuV/m)	Detector Type
1	4824.000	-0.803	39.410	38.607	-35.393	74.000	54.00	PEAK
2	7236.000	5.497	39.370	44.866	-29.134	74.000	54.00	PEAK
3	9648.000	9.230	38.200	47.431	-26.569	74.000	54.00	PEAK
4	* 12070.000	11.522	37.180	48.702	-25.298	74.000	54.00	PEAK

Note:

1. All readings above 1GHz are performed with peak and/or average measurements as necessary.
2. Peak measurements: RBW = 1MHz, VBW = 3 MHz, Sweep: Auto.
3. Average measurements: RBW = 1MHz, VBW = 10 Hz, Sweep: Auto.
4. “ * ”, means this data is the worst emission level.
5. Measurement Level = Reading Level + Correct Factor.
6. The average measurement was not performed when the peak measured data under the limit of average detection.
7. The Emission above 13GHz were not included is because their levels are too low.

Site : CB1	Time : 2011/09/30 - 17:24
Limit : FCC_SpartC_15.247_H_03M_PK	Margin : 6
Probe : EFS_1-18G-1_0901 - HORIZONTAL	Power : AC120V/60Hz
EUT : Wireless N Day/Night Internet Camera	Note : Mode 1: Transmit_2437MHz_802.11_n(20MHz)

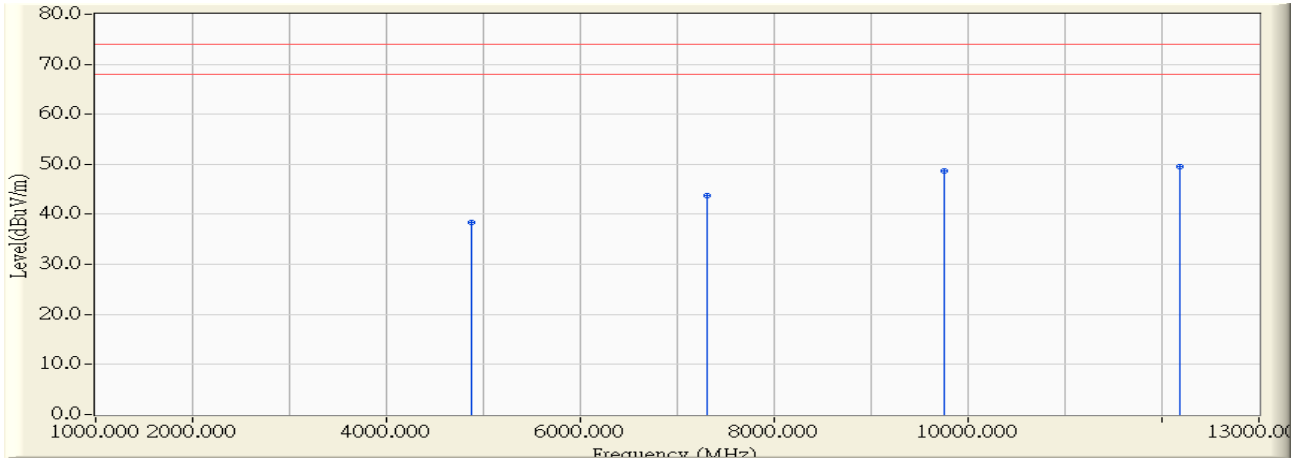

	Frequency (MHz)	Correct Factor (dB)	Reading Level (dBuV)	Measure Level (dBuV/m)	Margin (dB)	Peak Limit (dBuV/m)	Average Limit (dBuV/m)	Detector Type
1	4874.000	-0.672	39.150	38.478	-35.522	74.000	54.00	PEAK
2	7311.000	5.678	38.070	43.747	-30.253	74.000	54.00	PEAK
3	9748.000	9.955	38.700	48.655	-25.345	74.000	54.00	PEAK
4	* 12185.000	11.481	38.040	49.521	-24.479	74.000	54.00	PEAK

Note:

1. All readings above 1GHz are performed with peak and/or average measurements as necessary.
2. Peak measurements: RBW = 1MHz, VBW = 3 MHz, Sweep: Auto.
3. Average measurements: RBW = 1MHz, VBW = 10 Hz, Sweep: Auto.
4. “ * ”, means this data is the worst emission level.
5. Measurement Level = Reading Level + Correct Factor.
6. The average measurement was not performed when the peak measured data under the limit of average detection.
7. The Emission above 13GHz were not included is because their levels are too low.

Site : CB1	Time : 2011/09/30 - 17:27
Limit : FCC_SpartC_15.247_H_03M_PK	Margin : 6
Probe : EFS_1-18G-1_0901 - VERTICAL	Power : AC120V/60Hz
EUT : Wireless N Day/Night Internet Camera	Note : Mode 1: Transmit_2437MHz_802.11_n(20MHz)

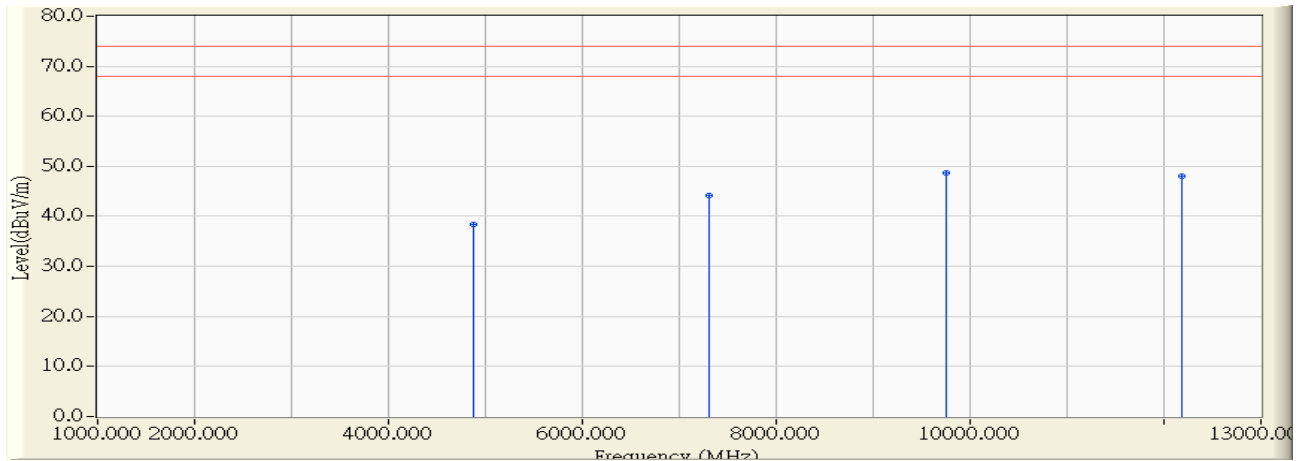

	Frequency (MHz)	Correct Factor (dB)	Reading Level (dBuV)	Measure Level (dBuV/m)	Margin (dB)	Peak Limit (dBuV/m)	Average Limit (dBuV/m)	Detector Type
1	4874.000	-0.672	39.090	38.418	-35.582	74.000	54.00	PEAK
2	7311.000	5.678	38.480	44.157	-29.843	74.000	54.00	PEAK
3	* 9748.000	9.955	38.650	48.605	-25.395	74.000	54.00	PEAK
4	12185.000	11.481	36.630	48.111	-25.889	74.000	54.00	PEAK

Note:

1. All readings above 1GHz are performed with peak and/or average measurements as necessary.
2. Peak measurements: RBW = 1MHz, VBW = 3 MHz, Sweep: Auto.
3. Average measurements: RBW = 1MHz, VBW = 10 Hz, Sweep: Auto.
4. “ * ”, means this data is the worst emission level.
5. Measurement Level = Reading Level + Correct Factor.
6. The average measurement was not performed when the peak measured data under the limit of average detection.
7. The Emission above 13GHz were not included is because their levels are too low.

Site : CB1	Time : 2011/09/30 - 17:33
Limit : FCC_SpartC_15.247_H_03M_PK	Margin : 6
Probe : EFS_1-18G-1_0901 - HORIZONTAL	Power : AC120V/60Hz
EUT : Wireless N Day/Night Internet Camera	Note : Mode 1: Transmit_2462MHz_802.11_n(20MHz)

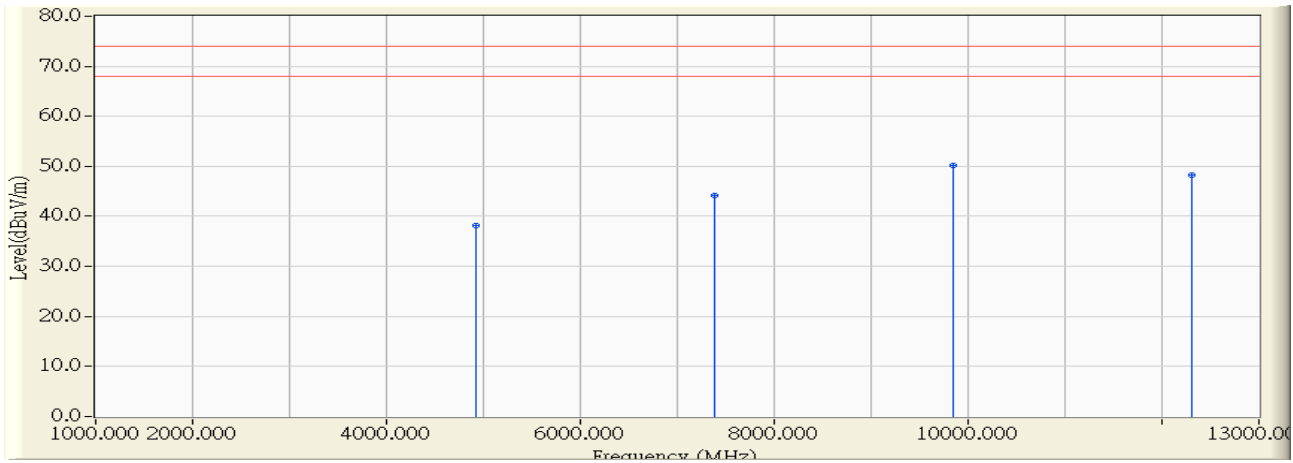

	Frequency (MHz)	Correct Factor (dB)	Reading Level (dBuV)	Measure Level (dBuV/m)	Margin (dB)	Peak Limit (dBuV/m)	Average Limit (dBuV/m)	Detector Type
1	4924.000	-0.541	38.620	38.079	-35.921	74.000	54.00	PEAK
2	7386.000	5.859	38.220	44.078	-29.922	74.000	54.00	PEAK
3	* 9848.000	10.680	39.590	50.270	-23.730	74.000	54.00	PEAK
4	12310.000	11.437	36.810	48.247	-25.753	74.000	54.00	PEAK

Note:

1. All readings above 1GHz are performed with peak and/or average measurements as necessary.
2. Peak measurements: RBW = 1MHz, VBW = 3 MHz, Sweep: Auto.
3. Average measurements: RBW = 1MHz, VBW = 10 Hz, Sweep: Auto.
4. “ * ”, means this data is the worst emission level.
5. Measurement Level = Reading Level + Correct Factor.
6. The average measurement was not performed when the peak measured data under the limit of average detection.
7. The Emission above 13GHz were not included is because their levels are too low.

Site : CB1	Time : 2011/09/30 - 17:38
Limit : FCC_SpartC_15.247_H_03M_PK	Margin : 6
Probe : EFS_1-18G-1_0901 - VERTICAL	Power : AC120V/60Hz
EUT : Wireless N Day/Night Internet Camera	Note : Mode 1: Transmit_2462MHz_802.11_n(20MHz)

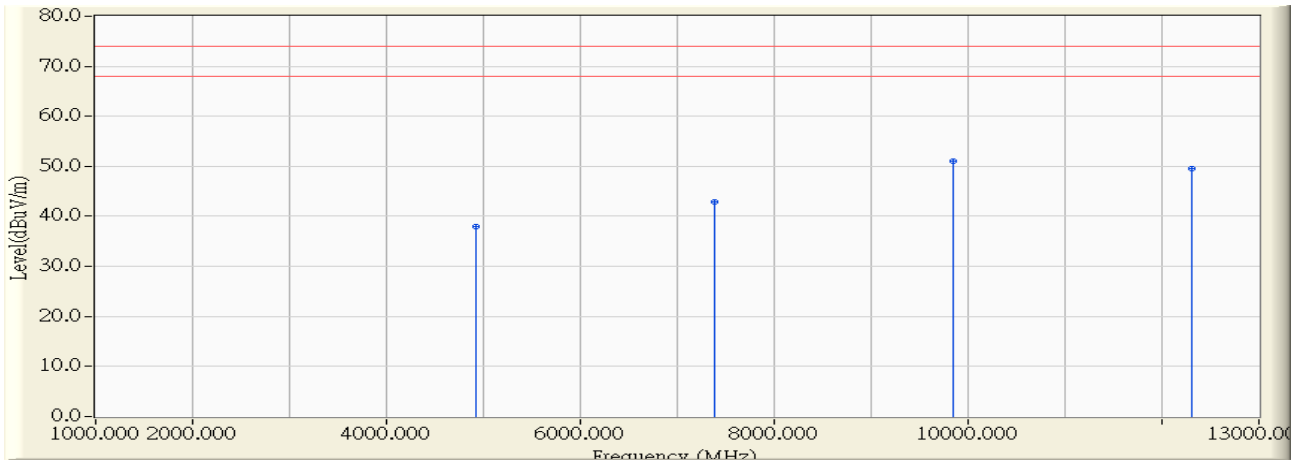

	Frequency (MHz)	Correct Factor (dB)	Reading Level (dBuV)	Measure Level (dBuV/m)	Margin (dB)	Peak Limit (dBuV/m)	Average Limit (dBuV/m)	Detector Type
1	4924.000	-0.541	38.450	37.909	-36.091	74.000	54.00	PEAK
2	7386.000	5.859	37.030	42.888	-31.112	74.000	54.00	PEAK
3	* 9848.000	10.680	40.420	51.100	-22.900	74.000	54.00	PEAK
4	12310.000	11.437	38.190	49.627	-24.373	74.000	54.00	PEAK

Note:

1. All readings above 1GHz are performed with peak and/or average measurements as necessary.
2. Peak measurements: RBW = 1MHz, VBW = 3 MHz, Sweep: Auto.
3. Average measurements: RBW = 1MHz, VBW = 10 Hz, Sweep: Auto.
4. “ * ”, means this data is the worst emission level.
5. Measurement Level = Reading Level + Correct Factor.
6. The average measurement was not performed when the peak measured data under the limit of average detection.
7. The Emission above 13GHz were not included is because their levels are too low.

Site : CB1	Time : 2011/09/30 - 17:43
Limit : FCC_SpartC_15.247_H_03M_PK	Margin : 6
Probe : EFS_1-18G-1_0901 - HORIZONTAL	Power : AC120V/60Hz
EUT : Wireless N Day/Night Internet Camera	Note : Mode 1: Transmit_2422MHz_802.11_n(40MHz)

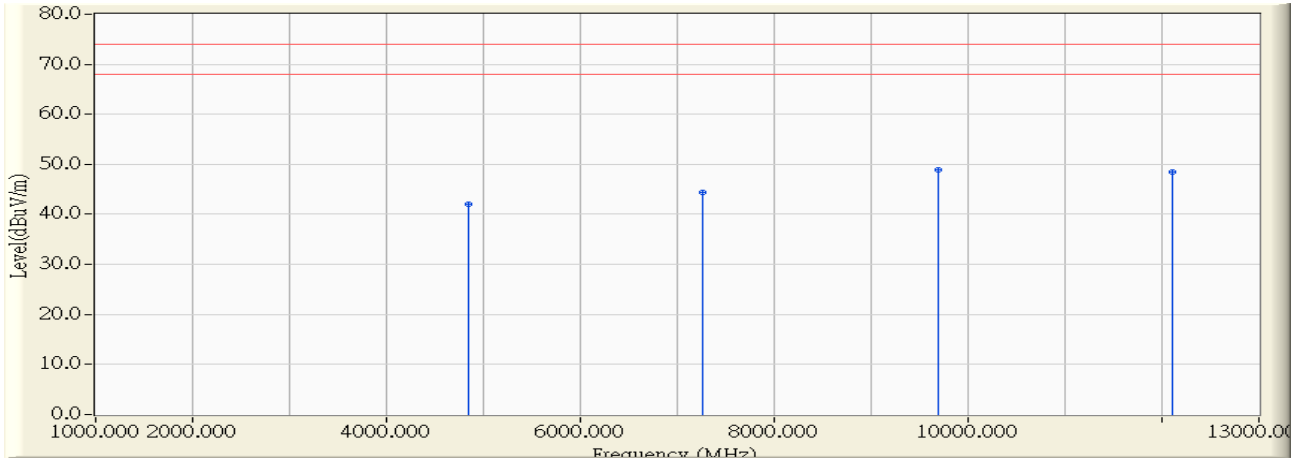

	Frequency (MHz)	Correct Factor (dB)	Reading Level (dBuV)	Measure Level (dBuV/m)	Margin (dB)	Peak Limit (dBuV/m)	Average Limit (dBuV/m)	Detector Type
1	4844.000	-0.751	42.720	41.969	-32.031	74.000	54.00	PEAK
2	7266.000	5.569	38.750	44.319	-29.681	74.000	54.00	PEAK
3	* 9688.000	9.520	39.390	48.911	-25.089	74.000	54.00	PEAK
4	12110.000	11.508	37.050	48.558	-25.442	74.000	54.00	PEAK

Note:

1. All readings above 1GHz are performed with peak and/or average measurements as necessary.
2. Peak measurements: RBW = 1MHz, VBW = 3 MHz, Sweep: Auto.
3. Average measurements: RBW = 1MHz, VBW = 10 Hz, Sweep: Auto.
4. “ * ”, means this data is the worst emission level.
5. Measurement Level = Reading Level + Correct Factor.
6. The average measurement was not performed when the peak measured data under the limit of average detection.
7. The Emission above 13GHz were not included is because their levels are too low.

Site : CB1	Time : 2011/09/30 - 17:46
Limit : FCC_SpartC_15.247_H_03M_PK	Margin : 6
Probe : EFS_1-18G-1_0901 - VERTICAL	Power : AC120V/60Hz
EUT : Wireless N Day/Night Internet Camera	Note : Mode 1: Transmit_2422MHz_802.11_n(40MHz)

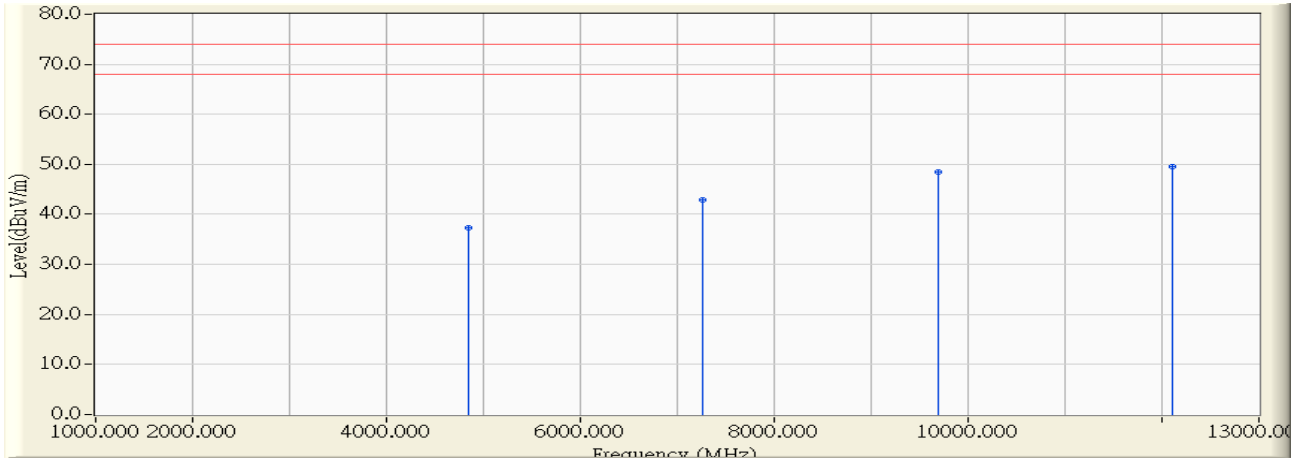

	Frequency (MHz)	Correct Factor (dB)	Reading Level (dBuV)	Measure Level (dBuV/m)	Margin (dB)	Peak Limit (dBuV/m)	Average Limit (dBuV/m)	Detector Type
1	4844.000	-0.751	38.020	37.269	-36.731	74.000	54.00	PEAK
2	7266.000	5.569	37.420	42.989	-31.011	74.000	54.00	PEAK
3	9688.000	9.520	38.970	48.491	-25.509	74.000	54.00	PEAK
4	* 12110.000	11.508	38.030	49.538	-24.462	74.000	54.00	PEAK

Note:

1. All readings above 1GHz are performed with peak and/or average measurements as necessary.
2. Peak measurements: RBW = 1MHz, VBW = 3 MHz, Sweep: Auto.
3. Average measurements: RBW = 1MHz, VBW = 10 Hz, Sweep: Auto.
4. “ * ”, means this data is the worst emission level.
5. Measurement Level = Reading Level + Correct Factor.
6. The average measurement was not performed when the peak measured data under the limit of average detection.
7. The Emission above 13GHz were not included is because their levels are too low.

Site : CB1	Time : 2011/10/03 - 09:23
Limit : FCC_SpartC_15.247_H_03M_PK	Margin : 6
Probe : EFS_1-18G-1_0901 - HORIZONTAL	Power : AC120V/60Hz
EUT : Wireless N Day/Night Internet Camera	Note : Mode 1: Transmit_2437MHz_802.11_n(40MHz)

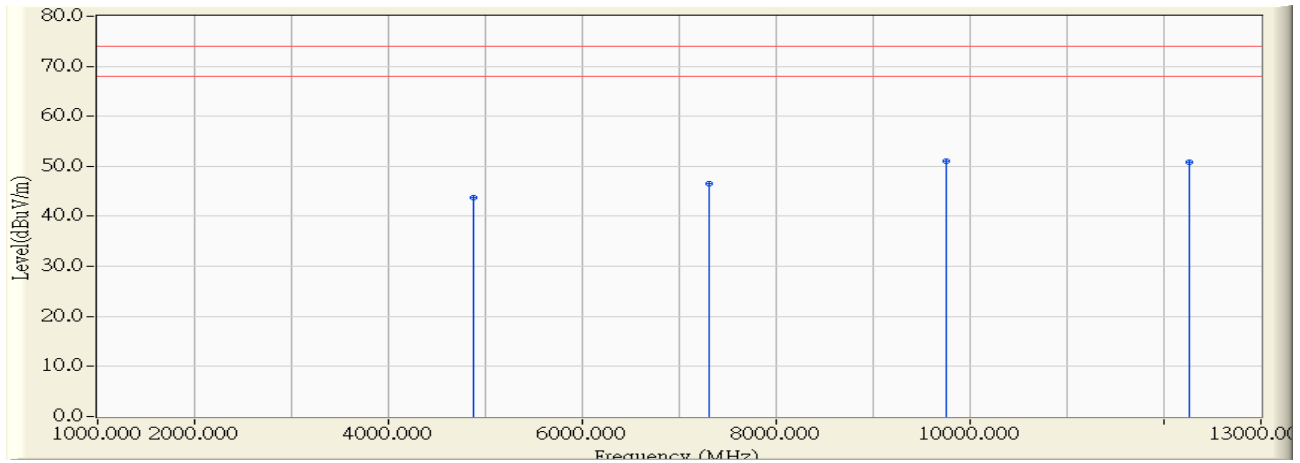

	Frequency (MHz)	Correct Factor (dB)	Reading Level (dBuV)	Measure Level (dBuV/m)	Margin (dB)	Peak Limit (dBuV/m)	Average Limit (dBuV/m)	Detector Type
1	4874.000	-0.672	44.520	43.848	-30.152	74.000	54.00	PEAK
2	7311.000	5.678	40.960	46.637	-27.363	74.000	54.00	PEAK
3	* 9748.000	9.955	40.990	50.945	-23.055	74.000	54.00	PEAK
4	12185.000	11.456	39.370	50.826	-23.174	74.000	54.00	PEAK

Note:

1. All readings above 1GHz are performed with peak and/or average measurements as necessary.
2. Peak measurements: RBW = 1MHz, VBW = 3 MHz, Sweep: Auto.
3. Average measurements: RBW = 1MHz, VBW = 10 Hz, Sweep: Auto.
4. “ * ”, means this data is the worst emission level.
5. Measurement Level = Reading Level + Correct Factor.
6. The average measurement was not performed when the peak measured data under the limit of average detection.
7. The Emission above 13GHz were not included is because their levels are too low.

Site : CB1	Time : 2011/10/03 - 09:35
Limit : FCC_SpartC_15.247_H_03M_PK	Margin : 6
Probe : EFS_1-18G-1_0901 - VERTICAL	Power : AC120V/60Hz
EUT : Wireless N Day/Night Internet Camera	Note : Mode 1: Transmit_2437MHz_802.11_n(40MHz)

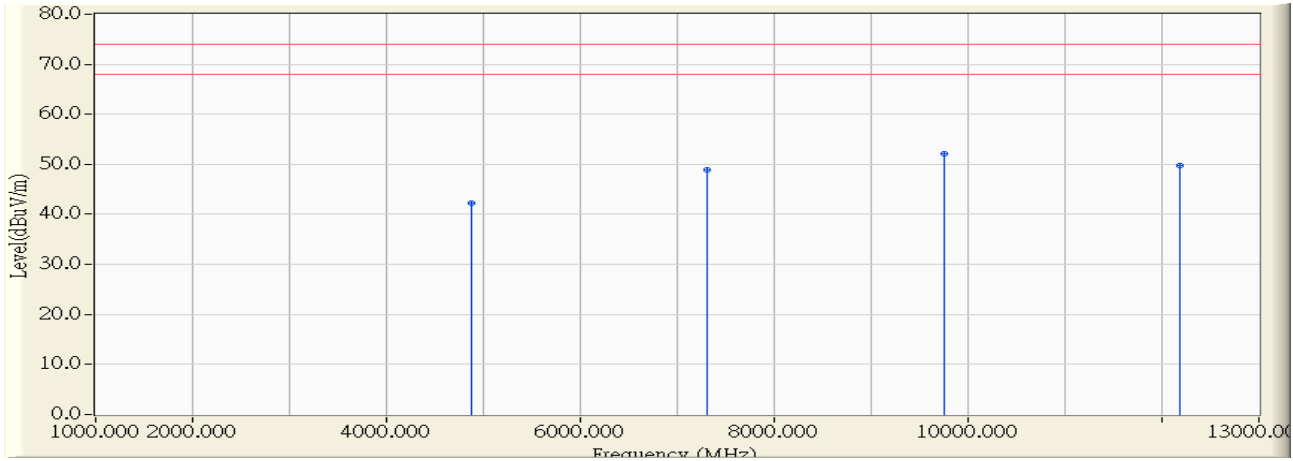

	Frequency (MHz)	Correct Factor (dB)	Reading Level (dBuV)	Measure Level (dBuV/m)	Margin (dB)	Peak Limit (dBuV/m)	Average Limit (dBuV/m)	Detector Type
1	4874.000	-0.672	43.020	42.348	-31.652	74.000	54.00	PEAK
2	7311.000	5.678	43.120	48.797	-25.203	74.000	54.00	PEAK
3	* 9748.000	9.955	42.070	52.025	-21.975	74.000	54.00	PEAK
4	12185.000	11.481	38.380	49.861	-24.139	74.000	54.00	PEAK

Note:

1. All readings above 1GHz are performed with peak and/or average measurements as necessary.
2. Peak measurements: RBW = 1MHz, VBW = 3 MHz, Sweep: Auto.
3. Average measurements: RBW = 1MHz, VBW = 10 Hz, Sweep: Auto.
4. “ * ”, means this data is the worst emission level.
5. Measurement Level = Reading Level + Correct Factor.
6. The average measurement was not performed when the peak measured data under the limit of average detection.
7. The Emission above 13GHz were not included is because their levels are too low.

Site : CB1	Time : 2011/10/03 - 09:50
Limit : FCC_SpartC_15.247_H_03M_PK	Margin : 6
Probe : EFS_1-18G-1_0901 - HORIZONTAL	Power : AC120V/60Hz
EUT : Wireless N Day/Night Internet Camera	Note : Mode 1: Transmit_2452MHz_802.11_n(40MHz)

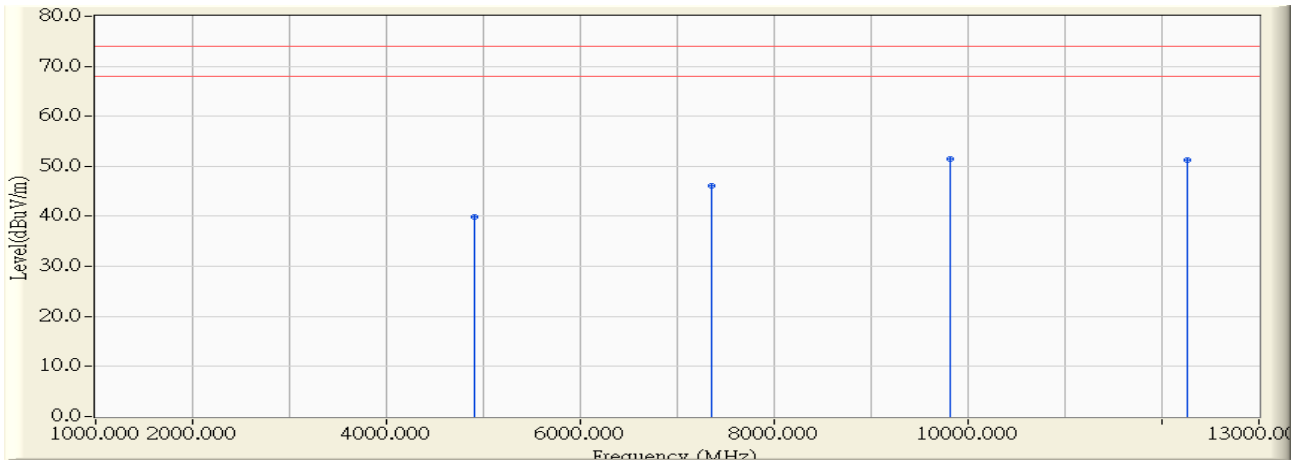

	Frequency (MHz)	Correct Factor (dB)	Reading Level (dBuV)	Measure Level (dBuV/m)	Margin (dB)	Peak Limit (dBuV/m)	Average Limit (dBuV/m)	Detector Type
1	4904.000	-0.593	40.460	39.867	-34.133	74.000	54.00	PEAK
2	7356.000	5.786	40.300	46.086	-27.914	74.000	54.00	PEAK
3	* 9808.000	10.390	41.000	51.390	-22.610	74.000	54.00	PEAK
4	12260.000	11.455	39.840	51.295	-22.705	74.000	54.00	PEAK

Note:

1. All readings above 1GHz are performed with peak and/or average measurements as necessary.
2. Peak measurements: RBW = 1MHz, VBW = 3 MHz, Sweep: Auto.
3. Average measurements: RBW = 1MHz, VBW = 10 Hz, Sweep: Auto.
4. “ * ”, means this data is the worst emission level.
5. Measurement Level = Reading Level + Correct Factor.
6. The average measurement was not performed when the peak measured data under the limit of average detection.
7. The Emission above 13GHz were not included is because their levels are too low.

Site : CB1	Time : 2011/10/03 - 09:54
Limit : FCC_SpartC_15.247_H_03M_PK	Margin : 6
Probe : EFS_1-18G-1_0901 - VERTICAL	Power : AC120V/60Hz
EUT : Wireless N Day/Night Internet Camera	Note : Mode 1: Transmit_2452MHz_802.11_n(40MHz)

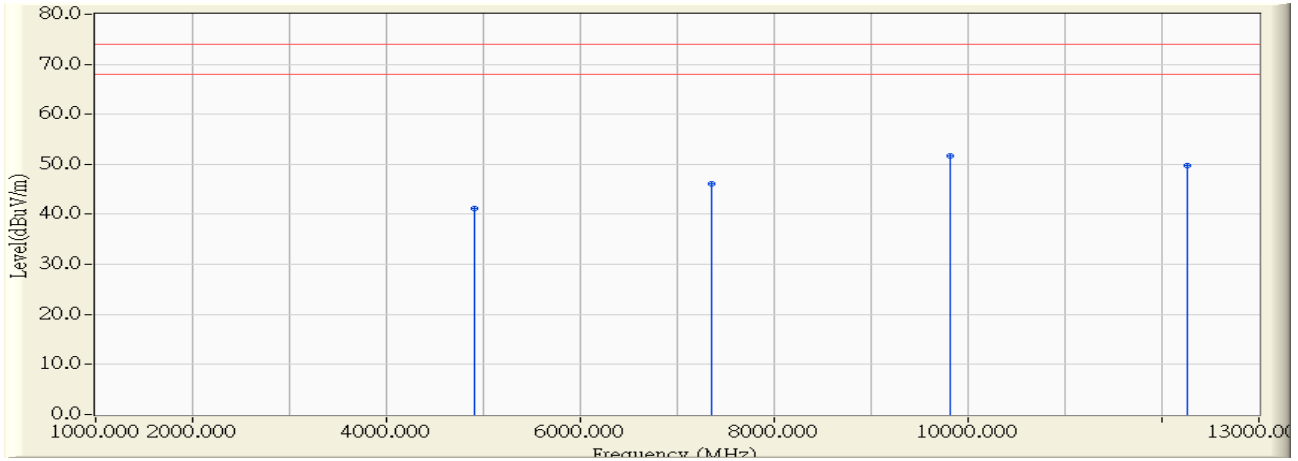

	Frequency (MHz)	Correct Factor (dB)	Reading Level (dBuV)	Measure Level (dBuV/m)	Margin (dB)	Peak Limit (dBuV/m)	Average Limit (dBuV/m)	Detector Type
1	4904.000	-0.593	41.710	41.117	-32.883	74.000	54.00	PEAK
2	7356.000	5.786	40.300	46.086	-27.914	74.000	54.00	PEAK
3	* 9808.000	10.390	41.380	51.770	-22.230	74.000	54.00	PEAK
4	12260.000	11.455	38.370	49.825	-24.175	74.000	54.00	PEAK

Note:

1. All readings above 1GHz are performed with peak and/or average measurements as necessary.
2. Peak measurements: RBW = 1MHz, VBW = 3 MHz, Sweep: Auto.
3. Average measurements: RBW = 1MHz, VBW = 10 Hz, Sweep: Auto.
4. “ * ”, means this data is the worst emission level.
5. Measurement Level = Reading Level + Correct Factor.
6. The average measurement was not performed when the peak measured data under the limit of average detection.
7. The Emission above 13GHz were not included is because their levels are too low.

5. RF antenna conducted test

5.1. Test Equipment

The following test equipments are used during the test:

RF antenna conducted test / SR7

Instrument	Manufacturer	Model No.	Serial No	Next Cal. Date
Spectrum Analyzer	R&S	FSP	100561	2012/01/16

Note: 1. All equipments that need to calibrate are with calibration period of 1 year.

5.2. Test Setup

RF Antenna Conducted Measurement:

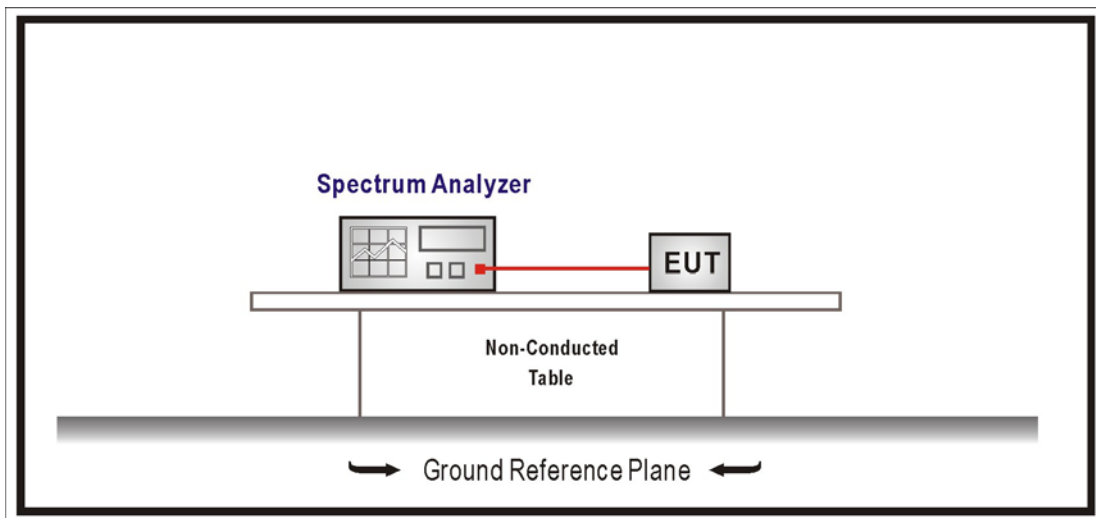

5.3. Limits

In any 100 kHz bandwidth outside the frequency band in which the spread spectrum intentional radiator is operating, the radio frequency power that is produced by the intentional radiator shall be at least 20 dB below that in the 100 kHz bandwidth within the band that contains the highest level of the desired power, based on an RF conducted or radiated measurement. Attenuation below the general limits specified in Section 15.209(a) is not required. In addition, radiated emissions which fall in the restricted bands, as defined in Section 15.205(a), must also comply with the radiated emission limits specified in Section 15.209(a) (see Section 15.205(c)).

5.4. Test Procedure

The EUT was setup according to ANSI C63.4: 2009 and tested according to DTS test procedure of Oct 2002 KDB558074 for compliance to FCC 47CFR 15.247 requirements Set RBW = 100 kHz, Set VBW > RBW, scan up through 10th harmonic.

5.5. Test Specification

According to FCC Part 15 Subpart C Paragraph 15.247: 2010

5.6. Uncertainty

Conducted is defined as $\pm 1.27\text{dB}$

5.7. Test Result

Product	Wireless N Day/Night Internet Camera		
Test Item	RF antenna conducted test		
Test Mode	Mode 1: Transmit		
Date of Test	2011/10/17	Test Site	SR7

IEEE 802.11b, Antenna Gain: 2dBi Duty Cycle: 1

Channel No.	Frequency (MHz)	Measure Level (dBc)	Limit (dBc)	Result
1	2412	44.04	≥20	Pass
11	2462	51.80	≥20	Pass

Channel 01 (2412MHz)

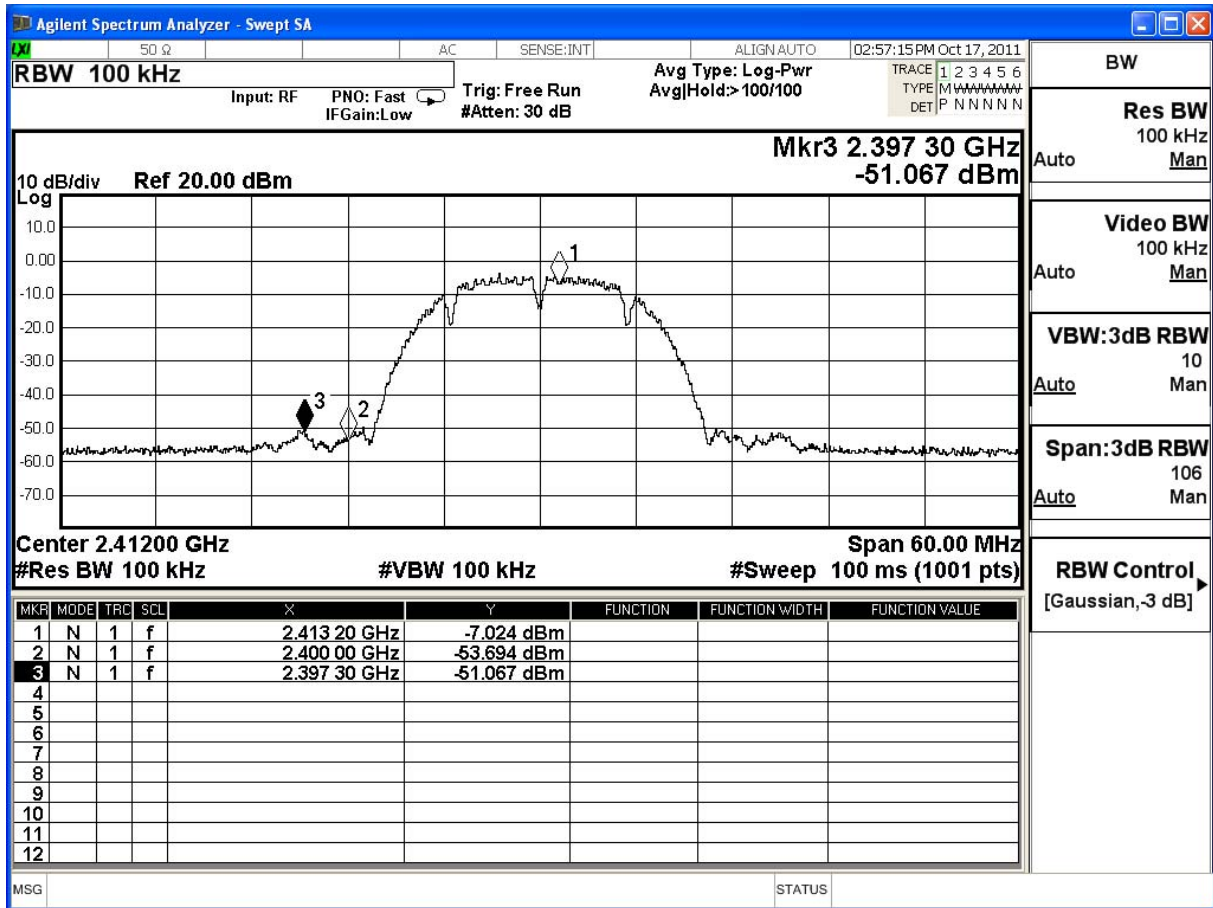

Channel 11 (2462MHz)

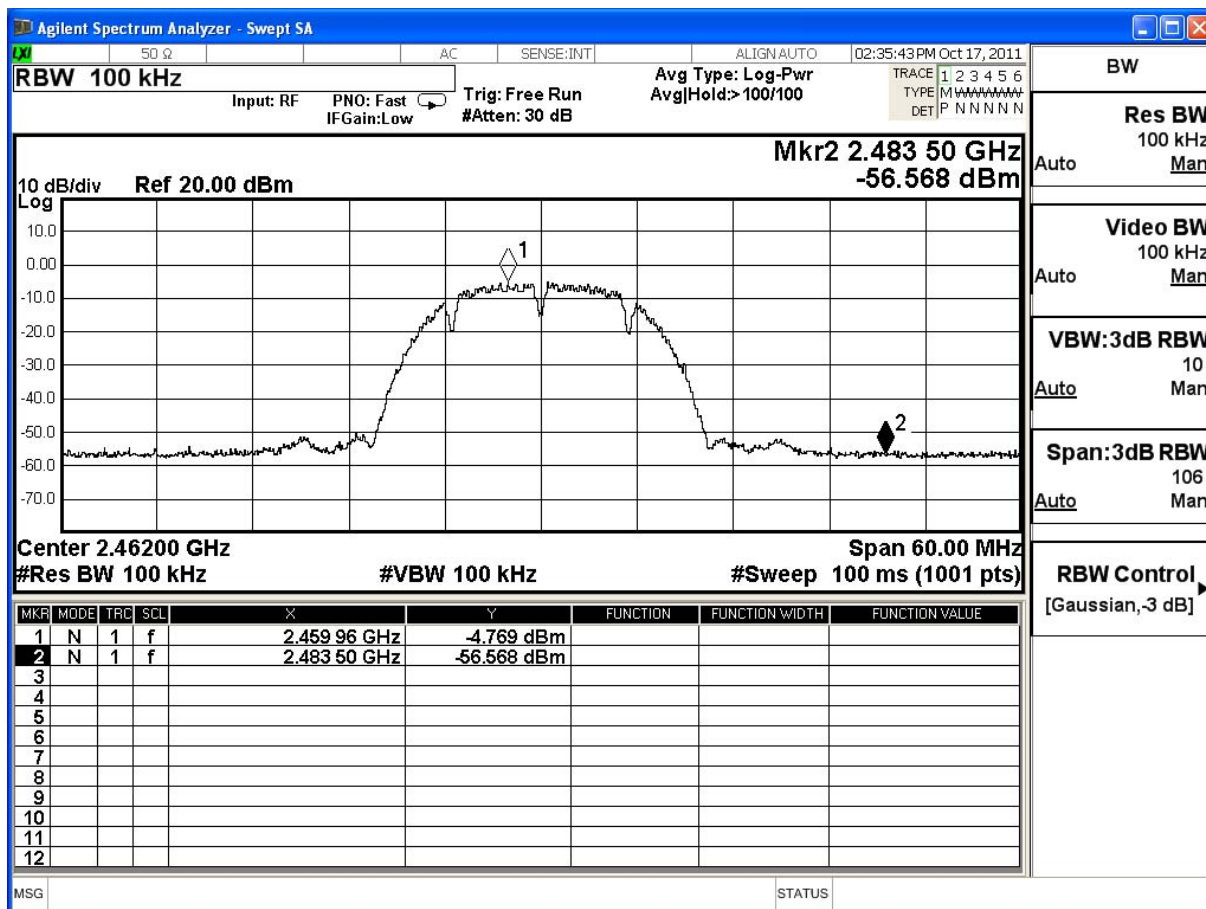

Product	Wireless N Day/Night Internet Camera		
Test Item	RF antenna conducted test		
Test Mode	Mode 1: Transmit		
Date of Test	2011/10/17	Test Site	SR7

IEEE 802.11g, Antenna Gain: 2dBi Duty Cycle: 1

Channel No.	Frequency (MHz)	Measure Level (dBc)	Limit (dBc)	Result
1	2412	34.55	≥20	Pass
11	2462	51.56	≥20	Pass

Channel 01 (2412MHz)

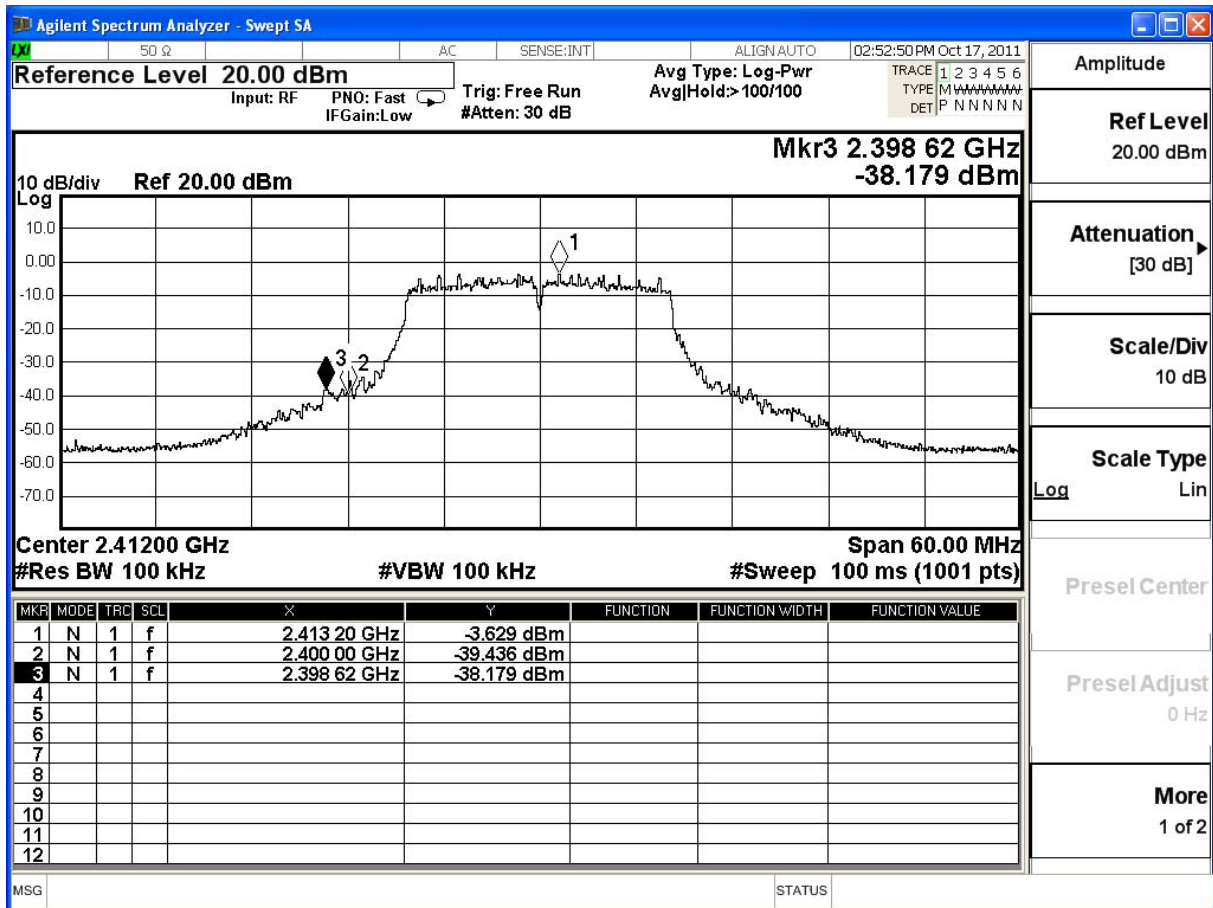

Channel 11 (2462MHz)

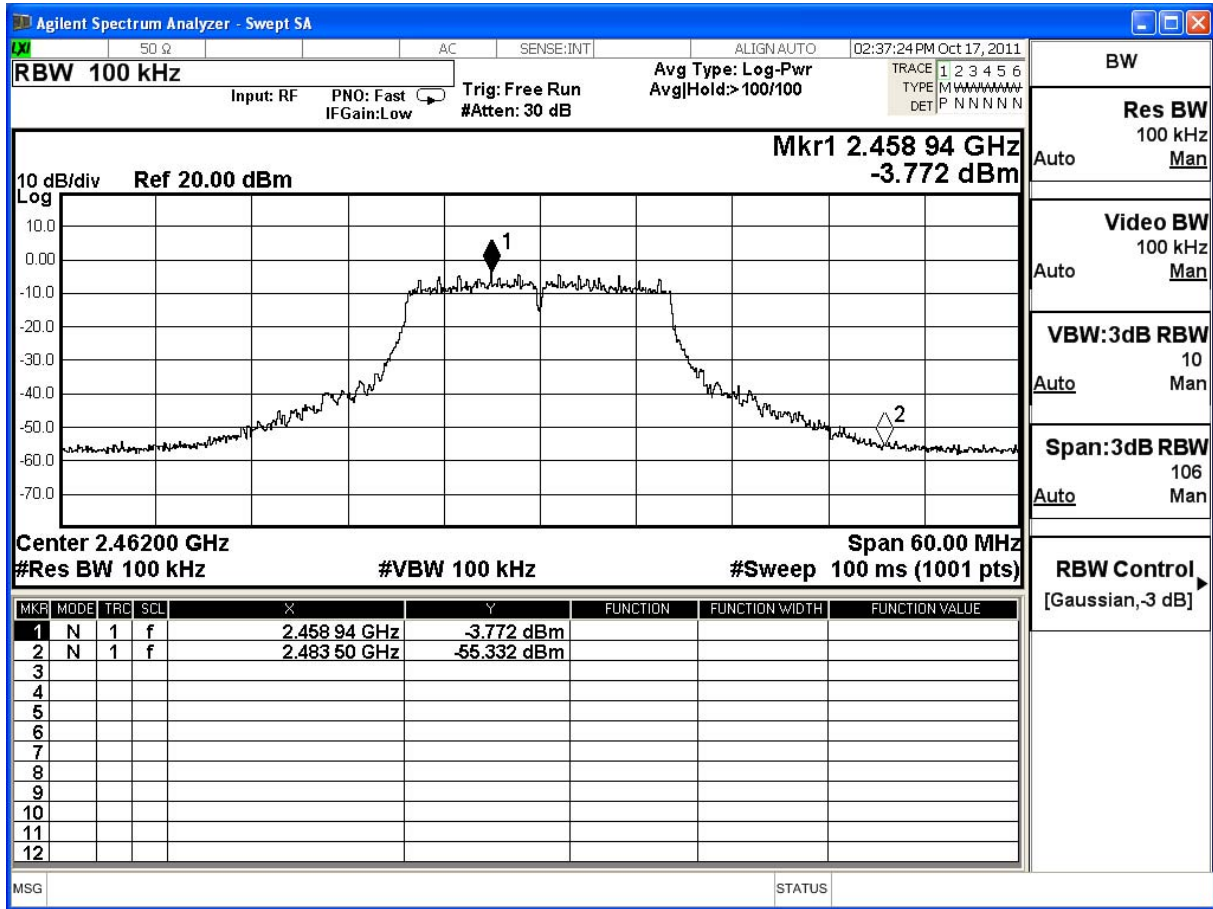

Product	Wireless N Day/Night Internet Camera		
Test Item	RF antenna conducted test		
Test Mode	Mode 1: Transmit		
Date of Test	2011/10/17	Test Site	SR7

IEEE 802.11n (20MHz), Antenna Gain: 2dBi Duty Cycle: 1

Channel No.	Frequency (MHz)	Measure Level (dBc)	Limit (dBc)	Result
1	2412	34.44	≥20	Pass
11	2462	46.89	≥20	Pass

Channel 1 (2412MHz)

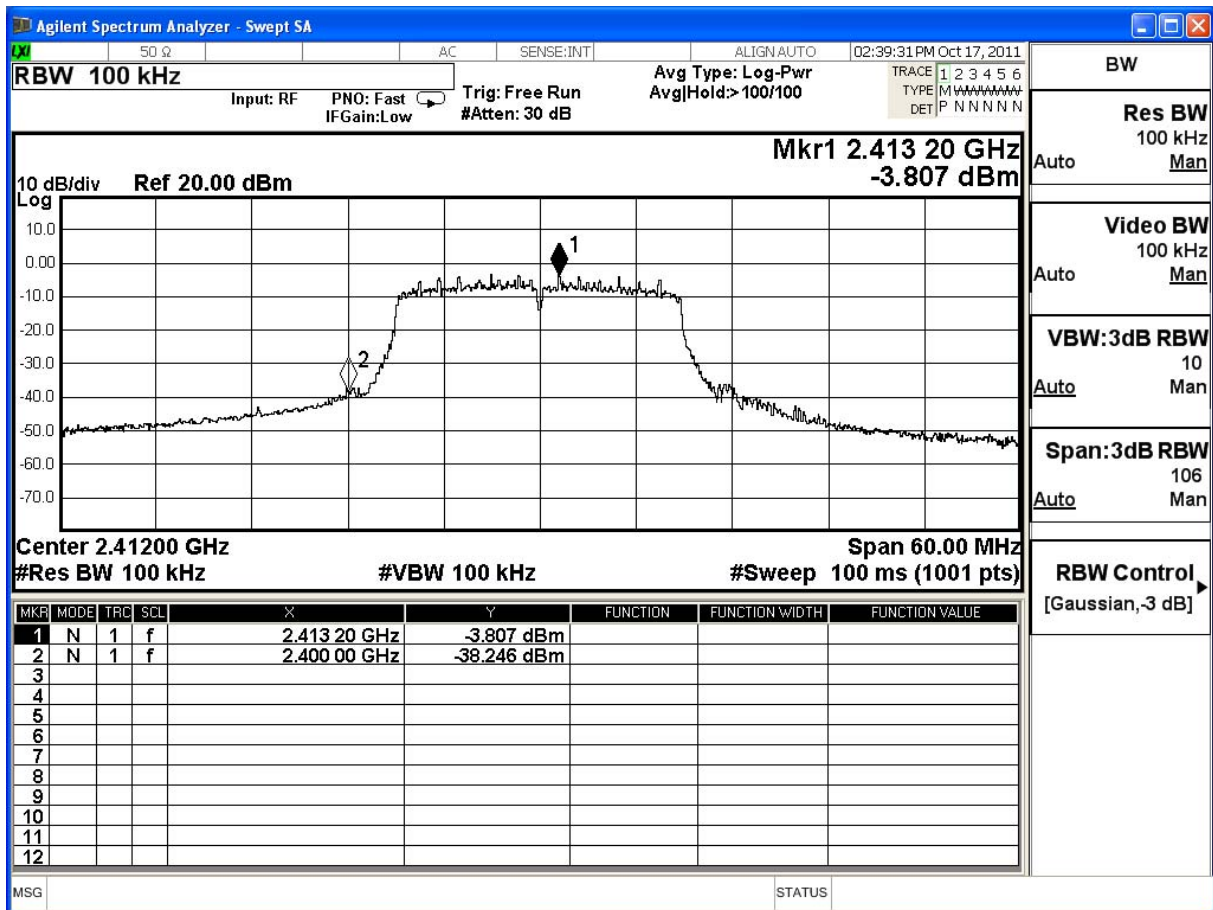

Channel 11 (2462MHz)

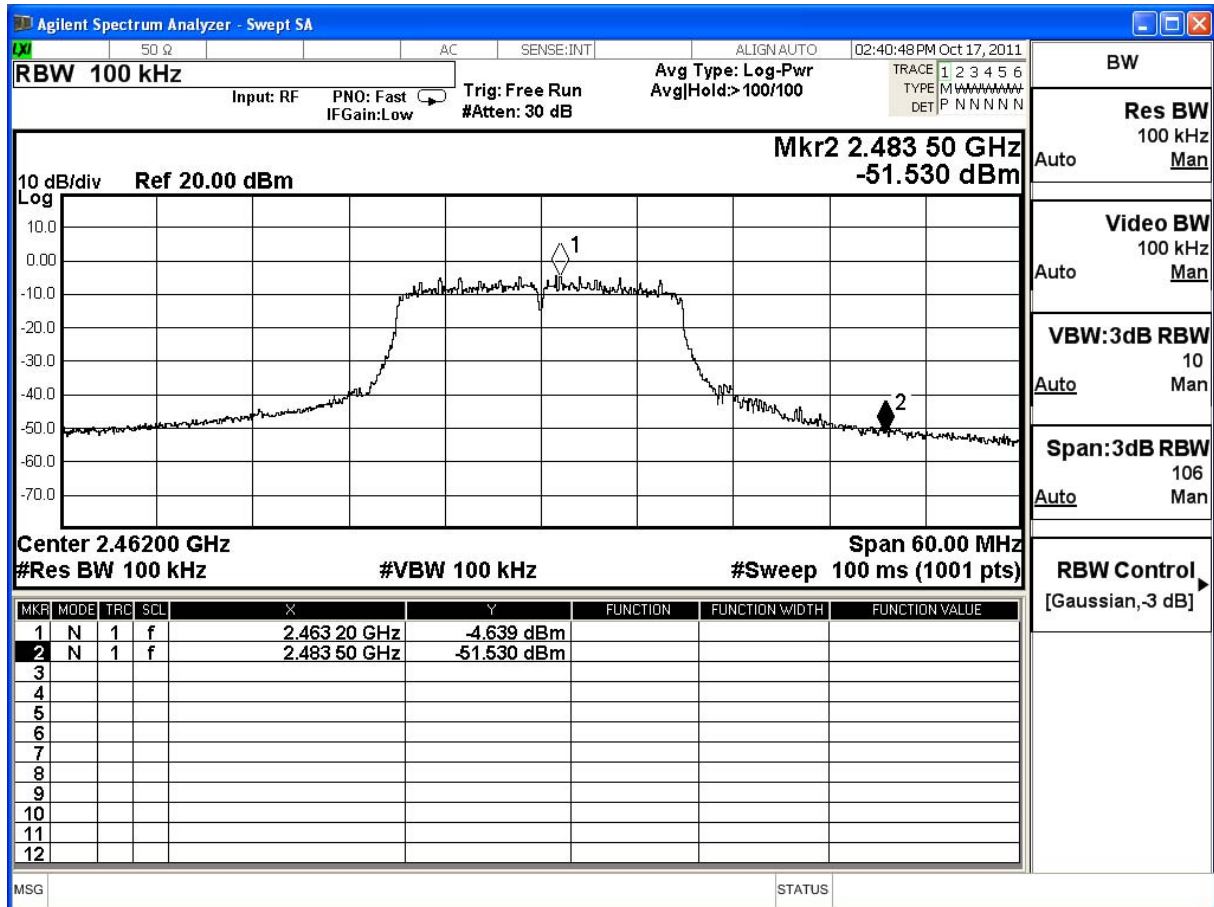

Product	Wireless N Day/Night Internet Camera		
Test Item	RF antenna conducted test		
Test Mode	Mode 1: Transmit		
Date of Test	2011/10/17	Test Site	SR7

IEEE 802.11n (40MHz), Antenna Gain: 2dBi Duty Cycle: 1				
Channel No.	Frequency (MHz)	Measure Level (dBc)	Limit (dBc)	Result
3	2422	31.71	≥20	Pass
9	2452	42.09	≥20	Pass

Channel 3 (2422MHz)

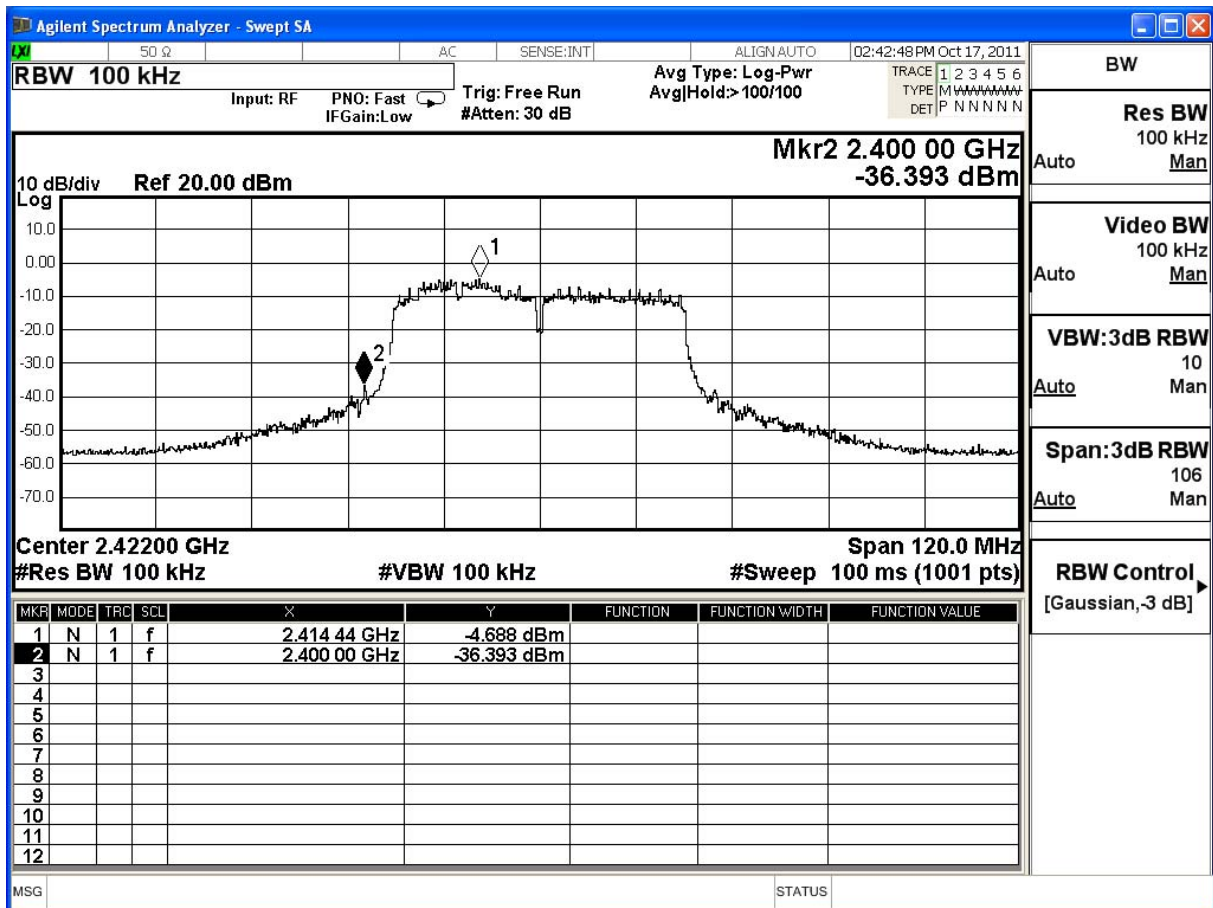

Channel 9 (2452MHz)

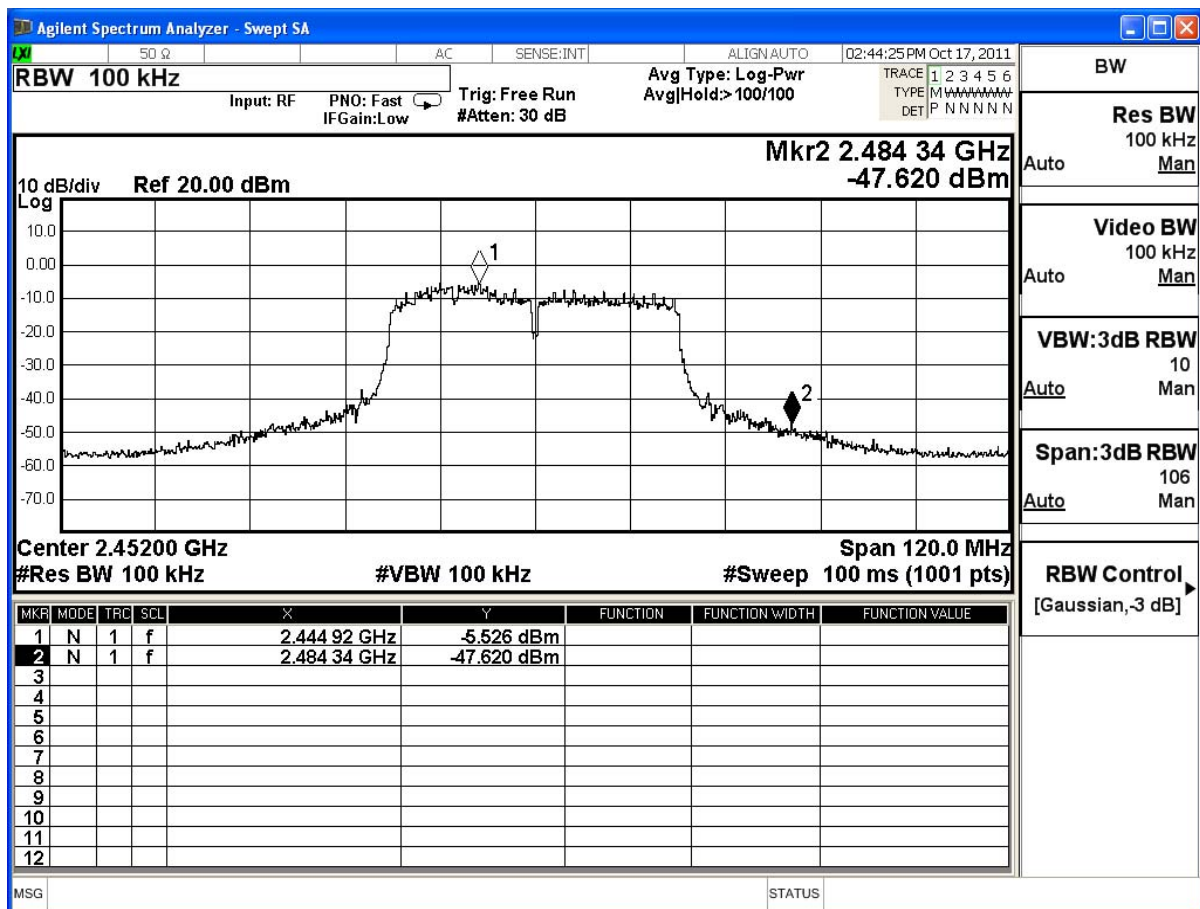

Product	Wireless N Day/Night Internet Camera		
Test Item	RF antenna conducted test		
Test Mode	Mode 1: Transmit		
Date of Test	2011/10/17	Test Site	SR7

2412MHz (30MHz-25GHz)-B

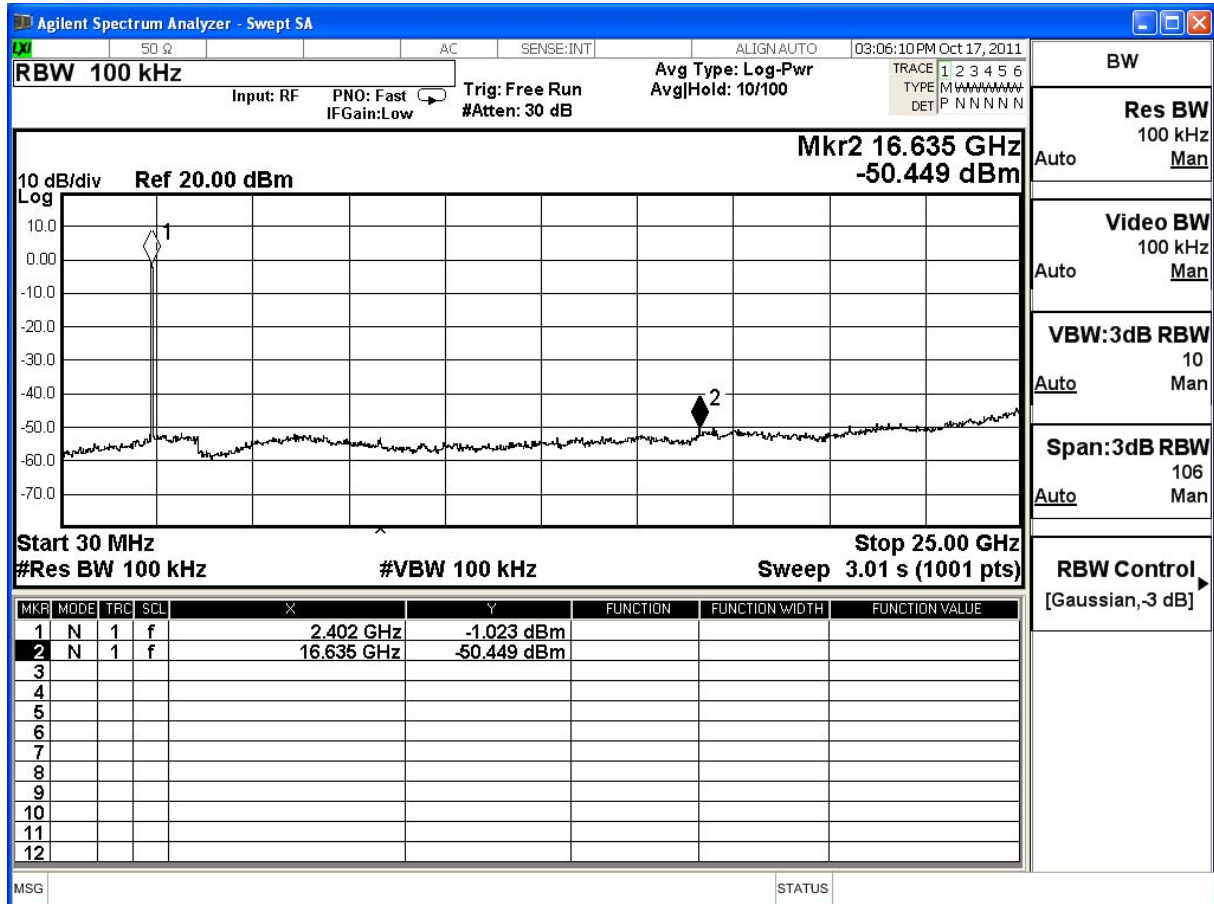

2462MHz (30MHz-25GHz)-B

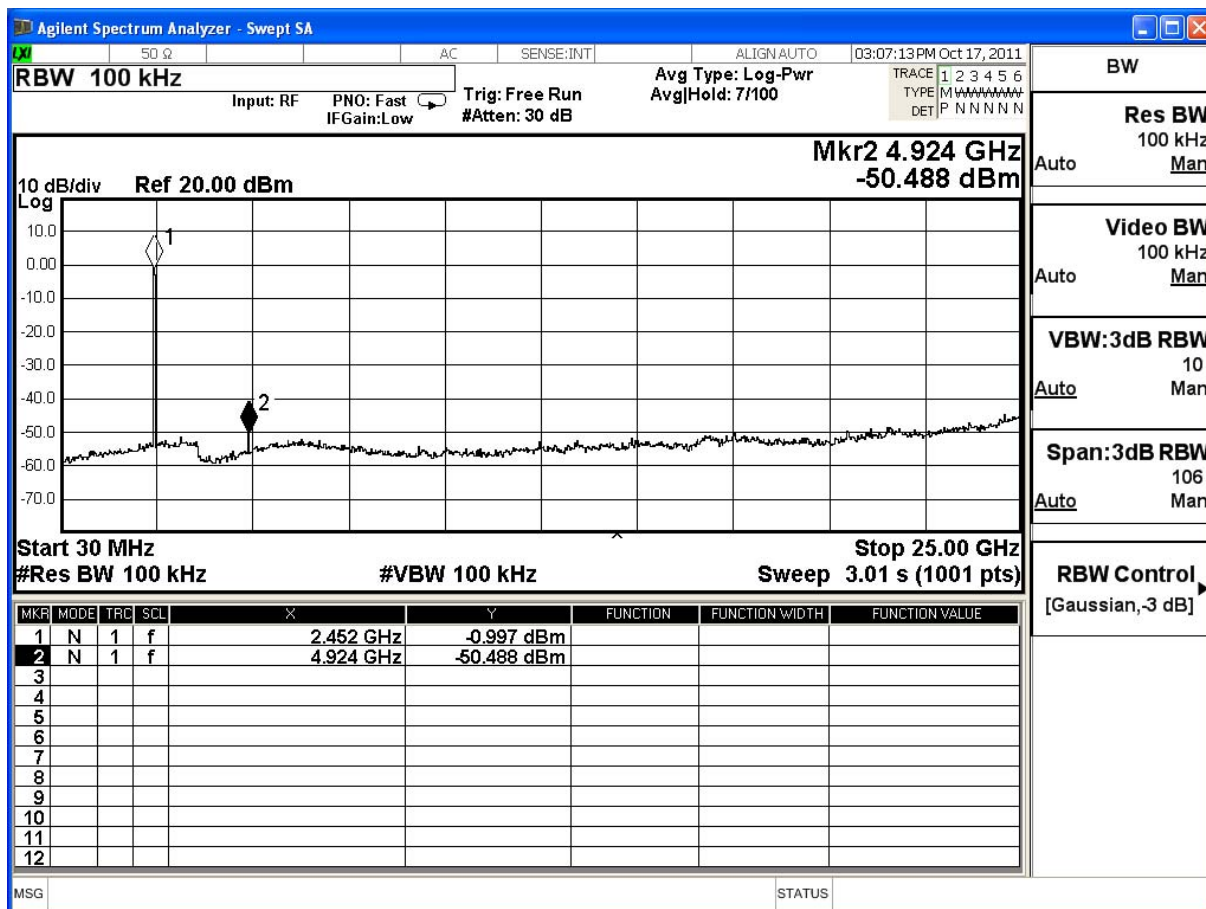

2412MHz (30MHz-25GHz)-G

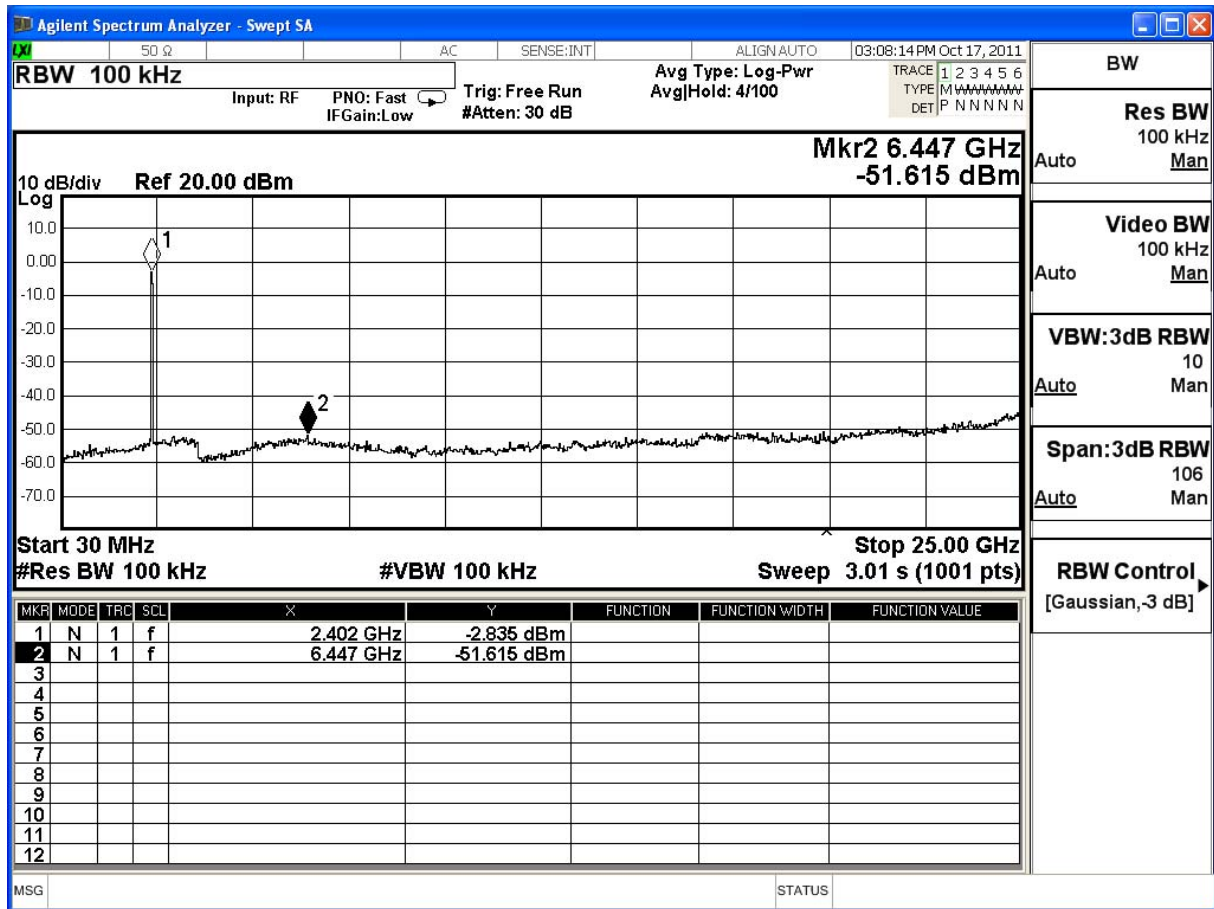

2462MHz (30MHz-25GHz)-G

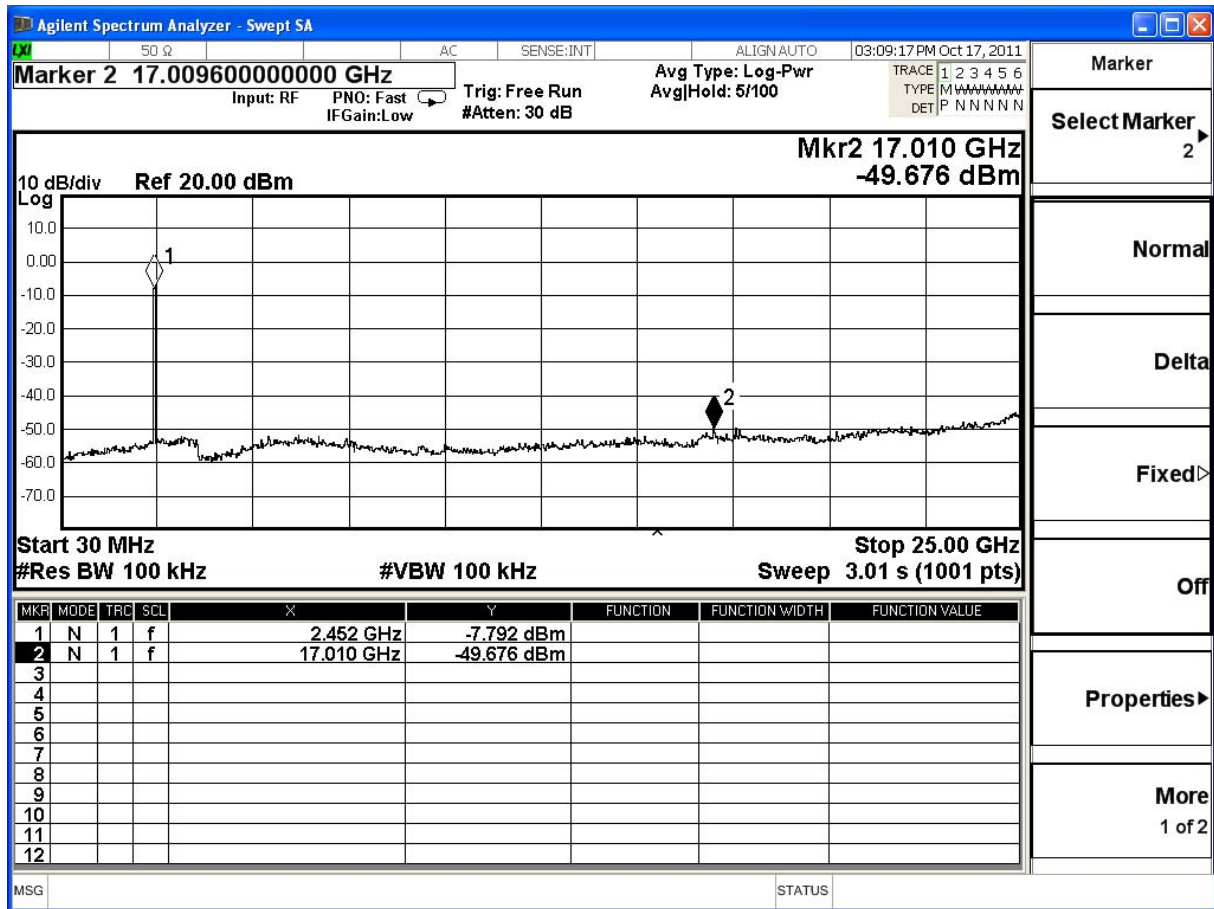

2412MHz (30MHz-25GHz)-N (20M)

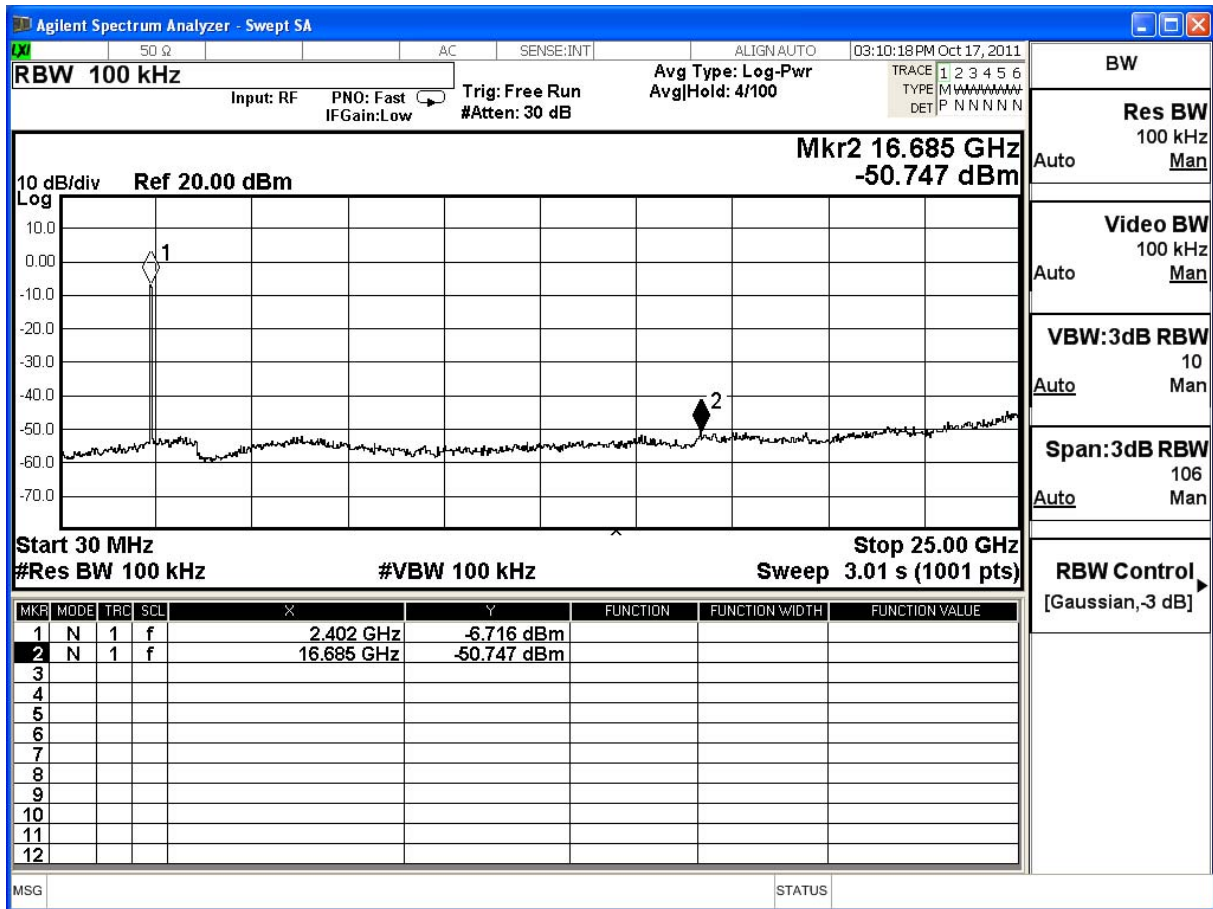

2462MHz (30MHz-25GHz)-N (20M)

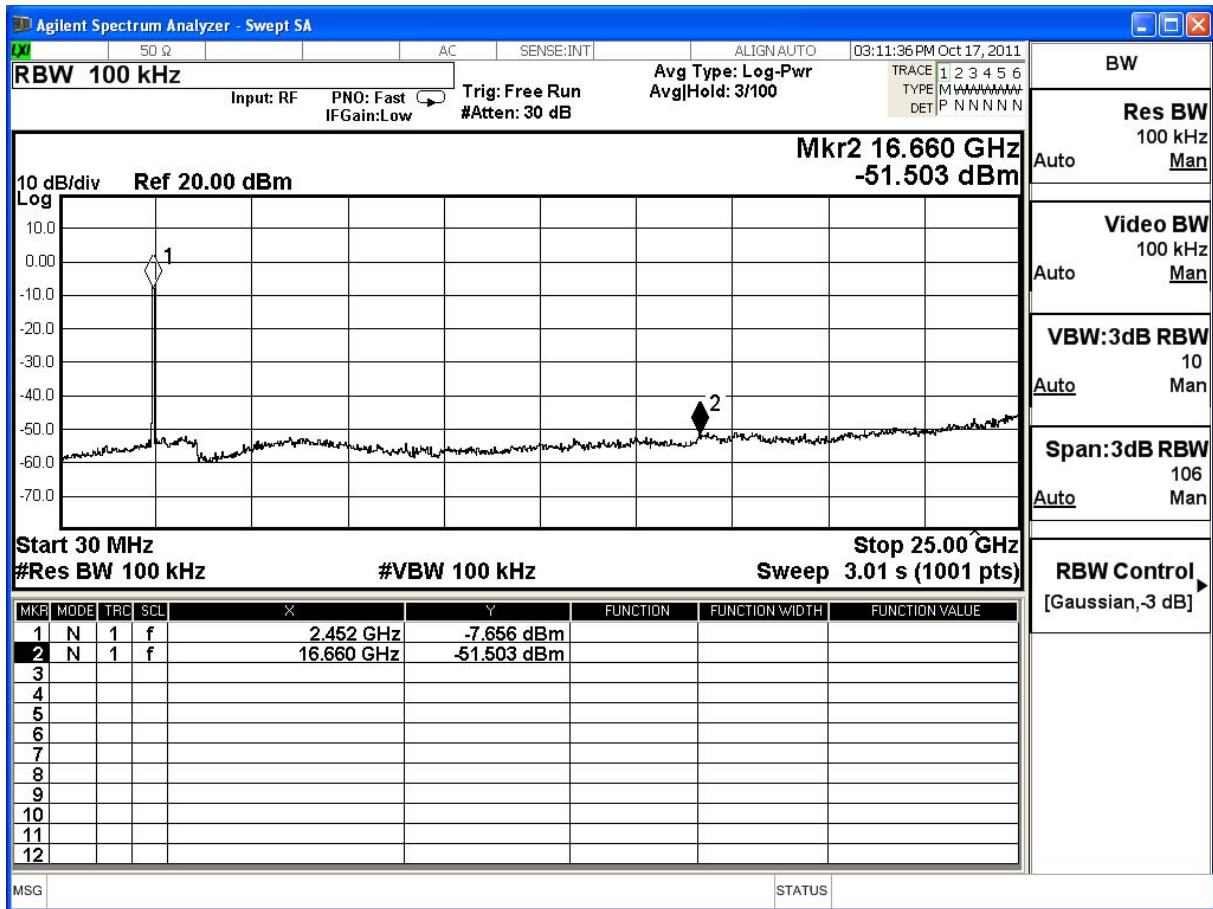

2422MHz (30MHz-25GHz)-N (40M)

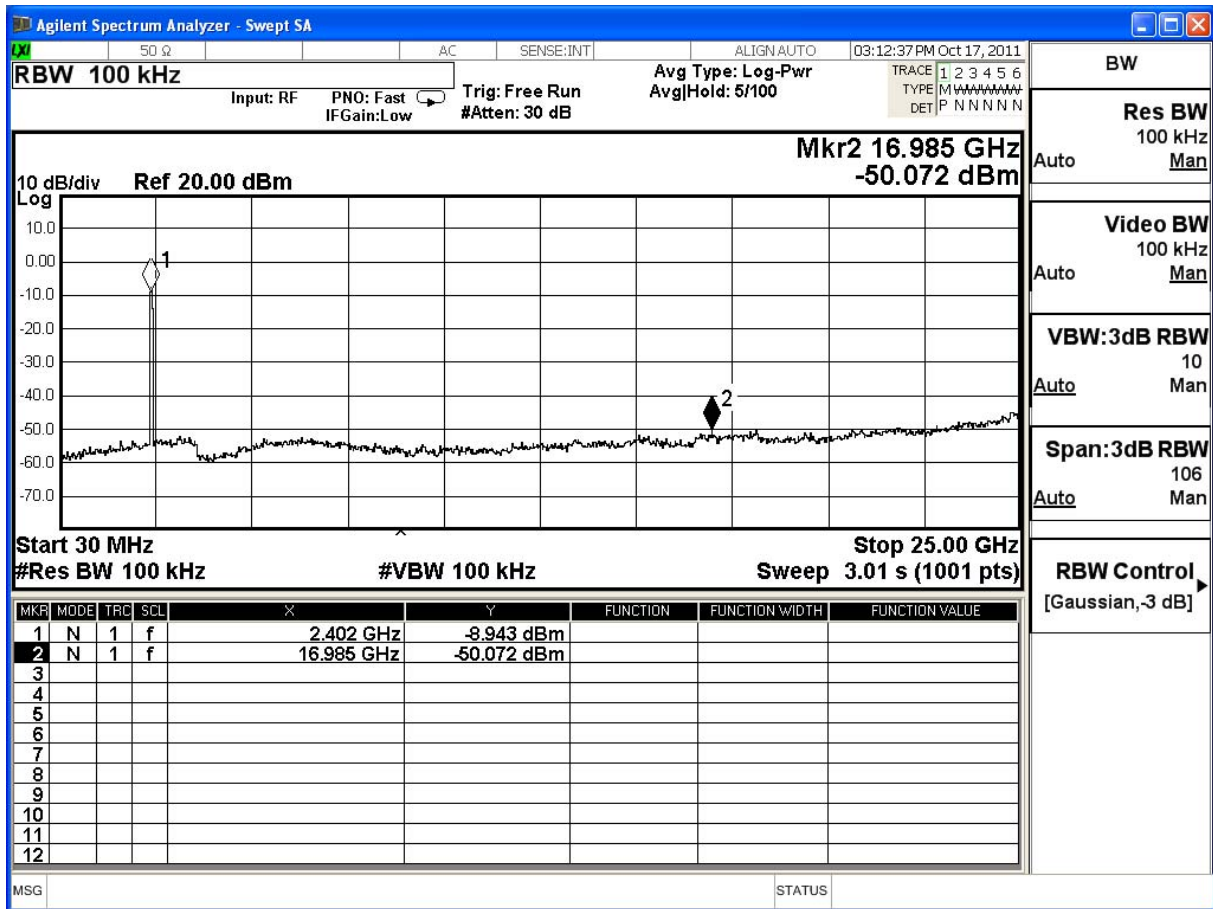

2452MHz (30MHz-25GHz)-N (40M)

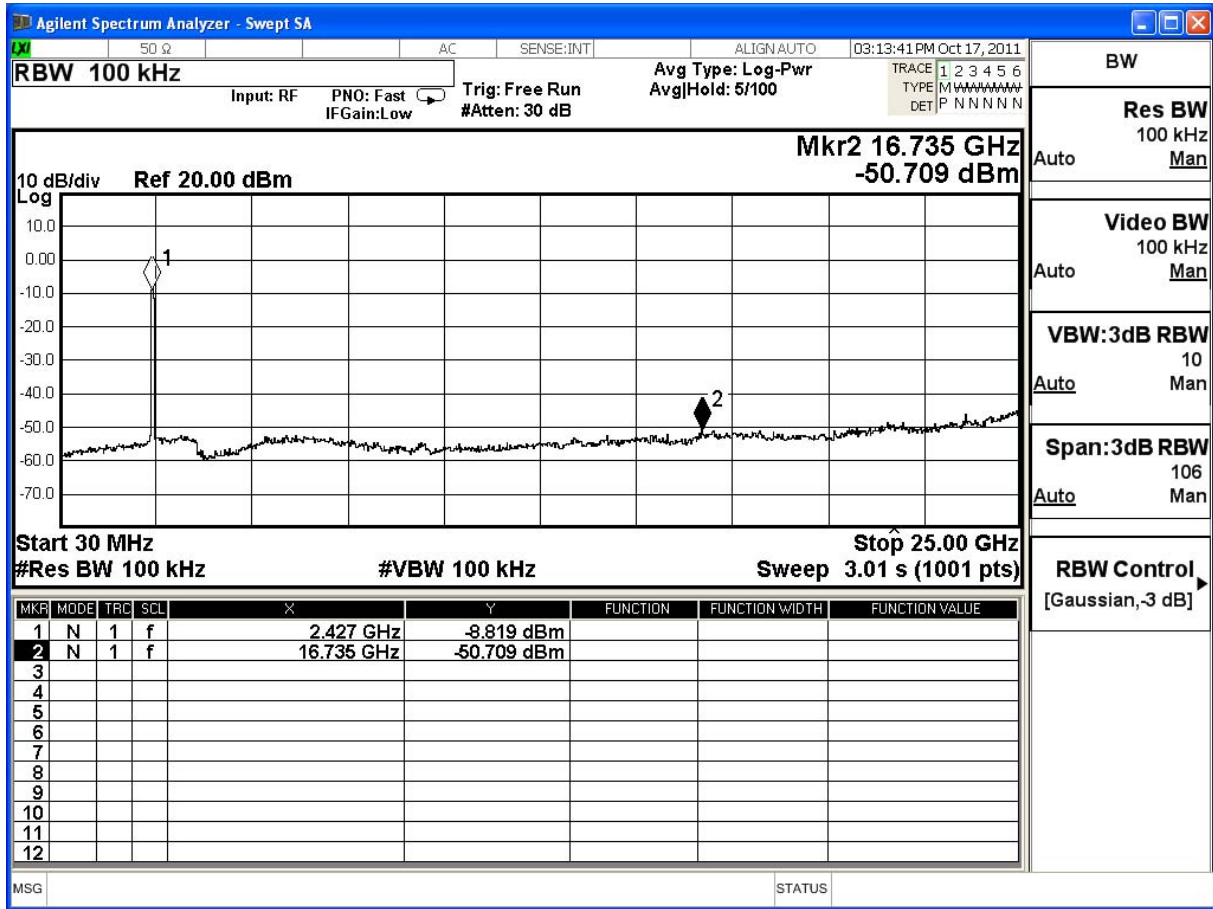

6. Radiated Emission Band Edge

6.1. Test Equipment

The following test equipments are used during the test:

Radiated Emission Band Edge / CB1

Instrument	Manufacturer	Model No.	Serial No	Next Cal. Date
Double Ridged Guide Horn Antenna	Schwarzback	BBHA 9120D	743	2012/02/24
PSA Series Spectrum analyzer	Agilent	E4440A	MY46187335	2012/01/06
Coaxial Cable	Huber+Suhner AG	Sucoflex 102	25623/2	2012/03/21

Note: 1. All equipments that need to calibrate are with calibration period of 1 year.

6.2. Test Setup

RF Radiated Measurement:

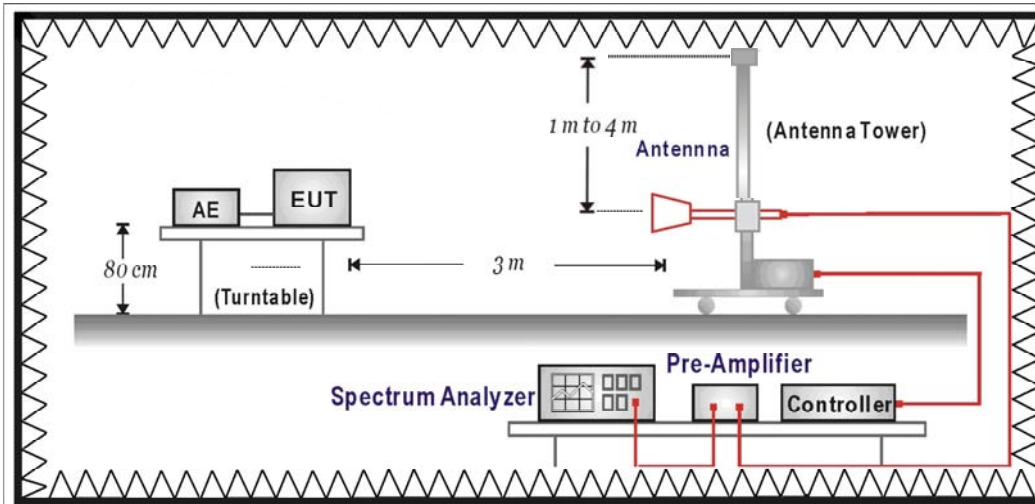

6.3. Limits

Emissions radiated outside of the specified frequency bands, except for harmonics, shall be attenuated by at least 20dB below the level of the fundamental or to the general radiated emission limits in paragraph 15.209, whichever is the lesser attenuation.

6.4. Test Procedure

The EUT was setup according to ANSI C63.4: 2009 and tested according to DTS test procedure of Oct 2002 KDB558074 for compliance to FCC 47CFR 15.247 requirements. The EUT and its simulators are placed on a turn table which is 0.8 meter above ground. The turn table can rotate 360 degrees to determine the position of the maximum emission level. The EUT was positioned such that the distance from antenna to the EUT was 3 meters.

The antenna can move up and down between 1 meter and 4 meters to find out the maximum emission level.

Both horizontal and vertical polarization of the antenna are set on measurement. In order to find the maximum emission, all of the interface cables must be manipulated according to ANSI C63.4: 2009 on radiated measurement.

6.5. Test Specification

According to FCC Part 15 Subpart C Paragraph 15.247: 2010

6.6. Uncertainty

The measurement uncertainty

± 3.9 dB above 1GHz

6.7. Test Result

Radiated is defined as

Site : CB1	Time : 2011/10/27 - 11:10
Limit : FCC_SpartC_15.209_03M_PK	Margin : 6
Probe : EFS_1-18G-1_0901 - HORIZONTAL	Power : AC120V/60Hz
EUT : Wireless N Day/Night Internet Camera	Note : Mode 1: Transmit_2412MHz_802.11_b

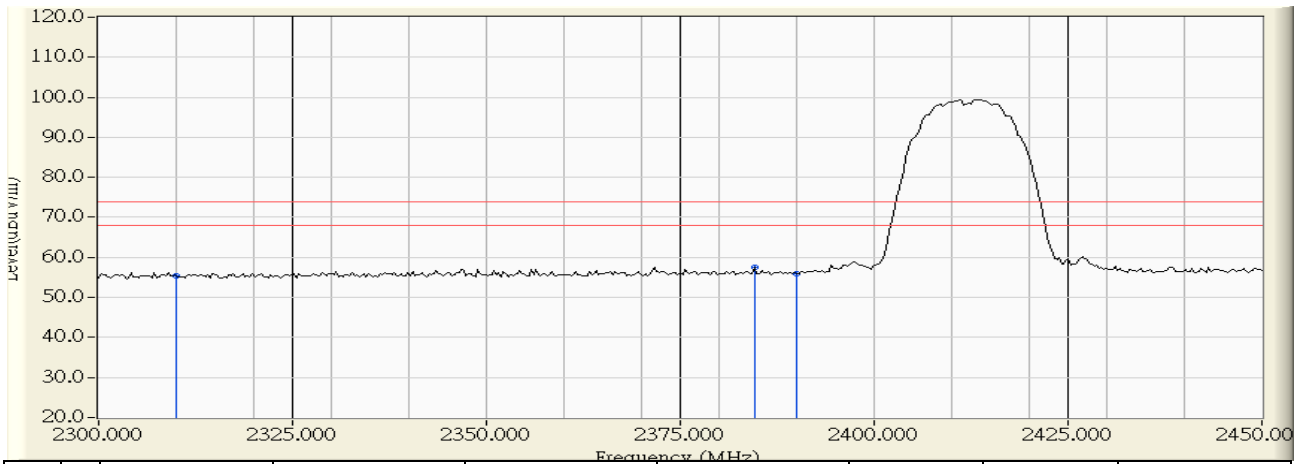

	Frequency (MHz)	Correct Factor (dB)	Reading Level (dBuV)	Measure Level (dBuV/m)	Margin (dB)	Limit (dBuV/m)	Detector Type
1	2310.000	29.779	25.683	55.462	-18.538	74.000	PEAK
2	* 2384.600	30.524	27.031	57.555	-16.445	74.000	PEAK
3	2390.000	30.578	25.320	55.898	-18.102	74.000	PEAK

Note:

1. All readings above 1GHz are performed with peak and/or average measurements as necessary.
2. Peak measurements: RBW = 1MHz, VBW = 3 MHz, Sweep: Auto.
3. Average measurements: RBW = 1MHz, VBW = 10 Hz, Sweep: Auto.
4. “ * ”, means this data is the worst emission level.
5. Measurement Level = Reading Level + Correct Factor.
6. The average measurement was not performed when the peak measured data under the limit of average detection.

Site : CB1	Time : 2011/10/27 - 11:16
Limit : FCC_SpartC_15.209_03M_AV	Margin : 6
Probe : EFS_1-18G-1_0901 - HORIZONTAL	Power : AC120V/60Hz
EUT : Wireless N Day/Night Internet Camera	Note : Mode 1: Transmit_2412MHz_802.11_b

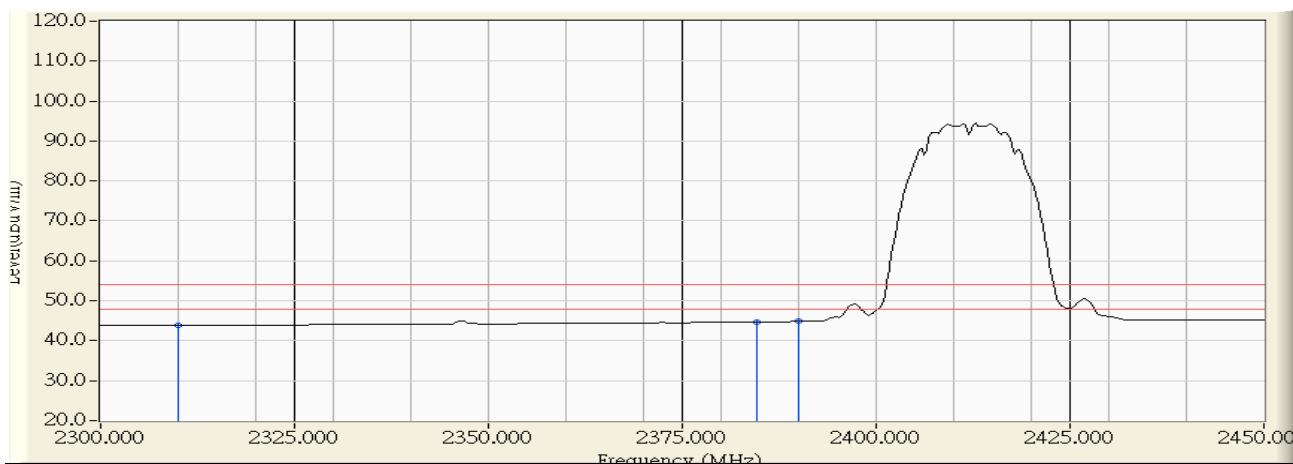

	Frequency (MHz)	Correct Factor (dB)	Reading Level (dBuV)	Measure Level (dBuV/m)	Margin (dB)	Limit (dBuV/m)	Detector Type
1	2310.000	29.779	14.023	43.802	-10.198	54.000	AVERAGE
2	2384.600	30.524	14.146	44.670	-9.330	54.000	AVERAGE
3	* 2390.000	30.578	14.287	44.865	-9.135	54.000	AVERAGE

Note:

1. All readings above 1GHz are performed with peak and/or average measurements as necessary.
2. Peak measurements: RBW = 1MHz, VBW = 3 MHz, Sweep: Auto.
3. Average measurements: RBW = 1MHz, VBW = 10 Hz, Sweep: Auto.
4. “ * ”, means this data is the worst emission level.
5. Measurement Level = Reading Level + Correct Factor.
6. The average measurement was not performed when the peak measured data under the limit of average detection.

Site : CB1	Time : 2011/10/27 - 11:19
Limit : FCC_SpartC_15.209_03M_PK	Margin : 6
Probe : EFS_1-18G-1_0901 - VERTICAL	Power : AC120V/60Hz
EUT : Wireless N Day/Night Internet Camera	Note : Mode 1: Transmit_2412MHz_802.11_b

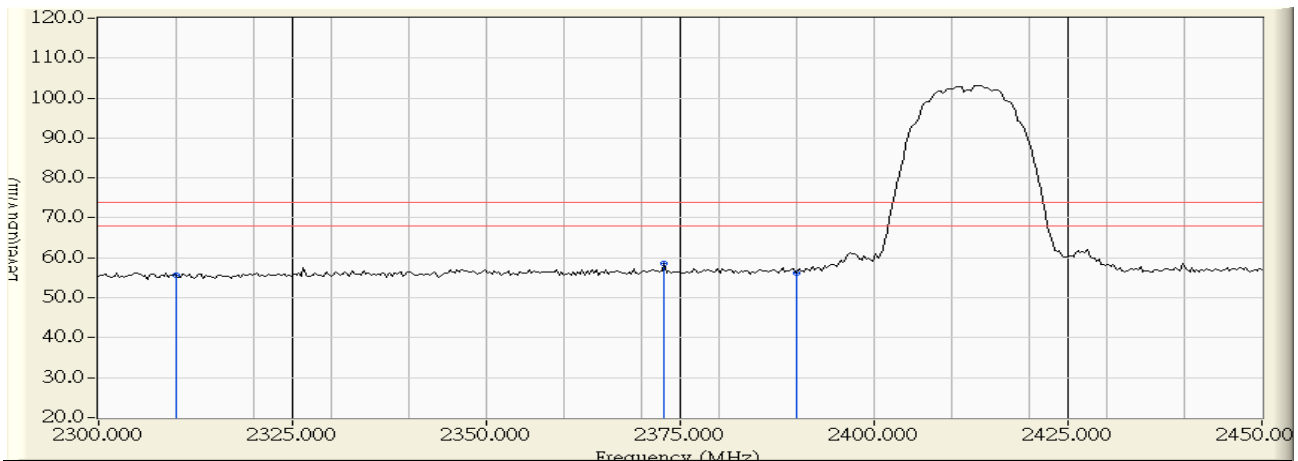

	Frequency (MHz)	Correct Factor (dB)	Reading Level (dBuV)	Measure Level (dBuV/m)	Margin (dB)	Limit (dBuV/m)	Detector Type
1	2310.000	29.779	25.868	55.647	-18.353	74.000	PEAK
2	* 2372.900	30.407	28.221	58.628	-15.372	74.000	PEAK
3	2390.000	30.578	25.729	56.307	-17.693	74.000	PEAK

Note:

1. All readings above 1GHz are performed with peak and/or average measurements as necessary.
2. Peak measurements: RBW = 1MHz, VBW = 3 MHz, Sweep: Auto.
3. Average measurements: RBW = 1MHz, VBW = 10 Hz, Sweep: Auto.
4. “ * ”, means this data is the worst emission level.
5. Measurement Level = Reading Level + Correct Factor.
6. The average measurement was not performed when the peak measured data under the limit of average detection.

Site : CB1	Time : 2011/10/27 - 11:21
Limit : FCC_SpartC_15.209_03M_AV	Margin : 6
Probe : EFS_1-18G-1_0901 - VERTICAL	Power : AC120V/60Hz
EUT : Wireless N Day/Night Internet Camera	Note : Mode 1: Transmit_2412MHz_802.11_b

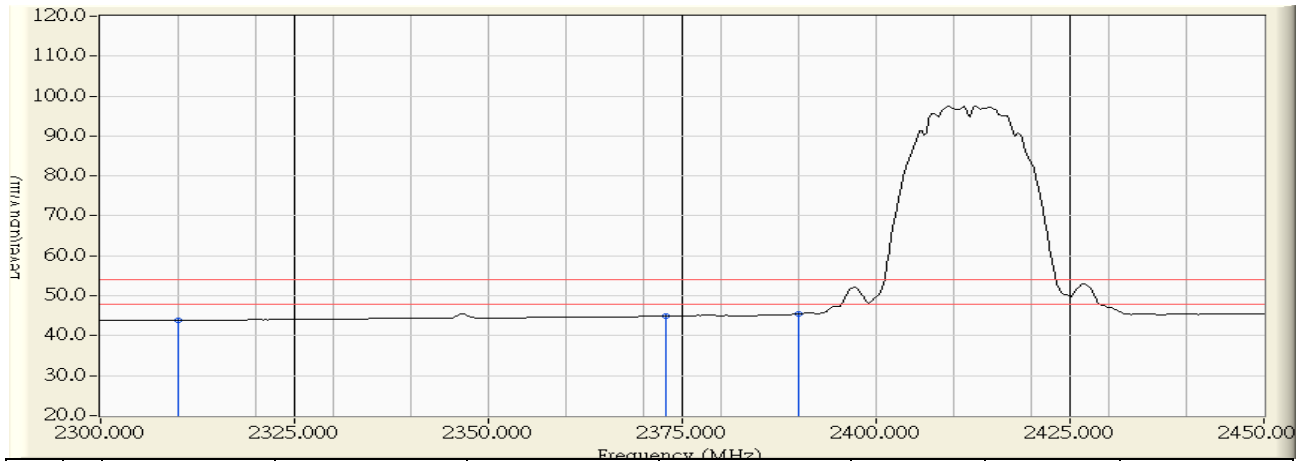

	Frequency (MHz)	Correct Factor (dB)	Reading Level (dBuV)	Measure Level (dBuV/m)	Margin (dB)	Limit (dBuV/m)	Detector Type
1	2310.000	29.779	14.115	43.894	-10.106	54.000	AVERAGE
2	2372.900	30.407	14.550	44.957	-9.043	54.000	AVERAGE
3	* 2390.000	30.578	14.836	45.414	-8.586	54.000	AVERAGE

Note:

1. All readings above 1GHz are performed with peak and/or average measurements as necessary.
2. Peak measurements: RBW = 1MHz, VBW = 3 MHz, Sweep: Auto.
3. Average measurements: RBW = 1MHz, VBW = 10 Hz, Sweep: Auto.
4. “ * ”, means this data is the worst emission level.
5. Measurement Level = Reading Level + Correct Factor.
6. The average measurement was not performed when the peak measured data under the limit of average detection.

Site : CB1	Time : 2011/10/27 - 13:02
Limit : FCC_SpartC_15.209_03M_PK	Margin : 6
Probe : EFS_1-18G-1_0901 - HORIZONTAL	Power : AC120V/60Hz
EUT : Wireless N Day/Night Internet Camera	Note : Mode 1: Transmit_2462MHz_802.11_b

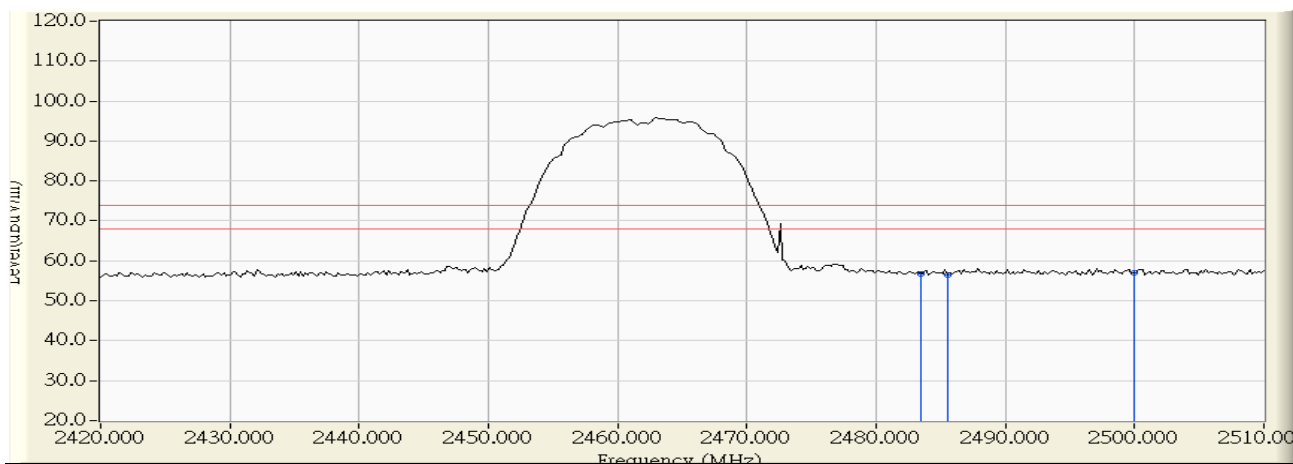

	Frequency (MHz)	Correct Factor (dB)	Reading Level (dBuV)	Measure Level (dBuV/m)	Margin (dB)	Limit (dBuV/m)	Detector Type
1	2483.500	31.512	25.323	56.835	-17.165	74.000	PEAK
2	2485.520	31.532	24.967	56.499	-17.501	74.000	PEAK
3	* 2500.000	31.638	25.359	56.998	-17.002	74.000	PEAK

Note:

1. All readings above 1GHz are performed with peak and/or average measurements as necessary.
2. Peak measurements: RBW = 1MHz, VBW = 3 MHz, Sweep: Auto.
3. Average measurements: RBW = 1MHz, VBW = 10 Hz, Sweep: Auto.
4. “ * ”, means this data is the worst emission level.
5. Measurement Level = Reading Level + Correct Factor.
6. The average measurement was not performed when the peak measured data under the limit of average detection.

Site : CB1	Time : 2011/10/27 - 13:03
Limit : FCC_SpartC_15.209_03M_AV	Margin : 6
Probe : EFS_1-18G-1_0901 - HORIZONTAL	Power : AC120V/60Hz
EUT : Wireless N Day/Night Internet Camera	Note : Mode 1: Transmit_2462MHz_802.11_b

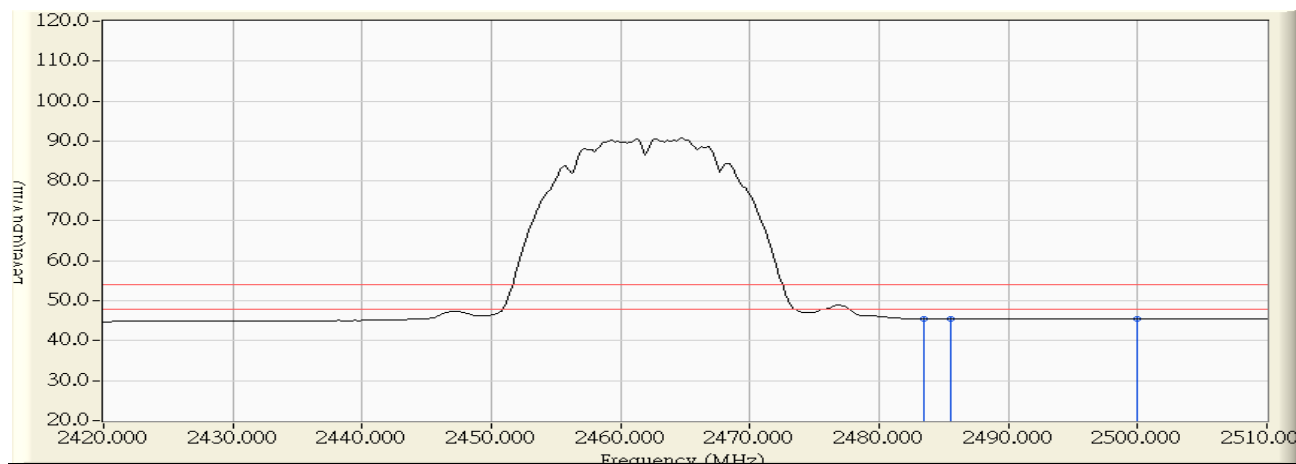

		Frequency (MHz)	Correct Factor (dB)	Reading Level (dBuV)	Measure Level (dBuV/m)	Margin (dB)	Limit (dBuV/m)	Detector Type
1	*	2483.500	31.512	14.007	45.519	-8.481	54.000	AVERAGE
2		2485.520	31.532	13.982	45.514	-8.486	54.000	AVERAGE
3		2500.000	31.638	13.783	45.422	-8.578	54.000	AVERAGE

Note:

1. All readings above 1GHz are performed with peak and/or average measurements as necessary.
2. Peak measurements: RBW = 1MHz, VBW = 3 MHz, Sweep: Auto.
3. Average measurements: RBW = 1MHz, VBW = 10 Hz, Sweep: Auto.
4. “ * ”, means this data is the worst emission level.
5. Measurement Level = Reading Level + Correct Factor.
6. The average measurement was not performed when the peak measured data under the limit of average detection.

Site : CB1	Time : 2011/10/27 - 13:06
Limit : FCC_SpartC_15.209_03M_PK	Margin : 6
Probe : EFS_1-18G-1_0901 - VERTICAL	Power : AC120V/60Hz
EUT : Wireless N Day/Night Internet Camera	Note : Mode 1: Transmit_2462MHz_802.11_b

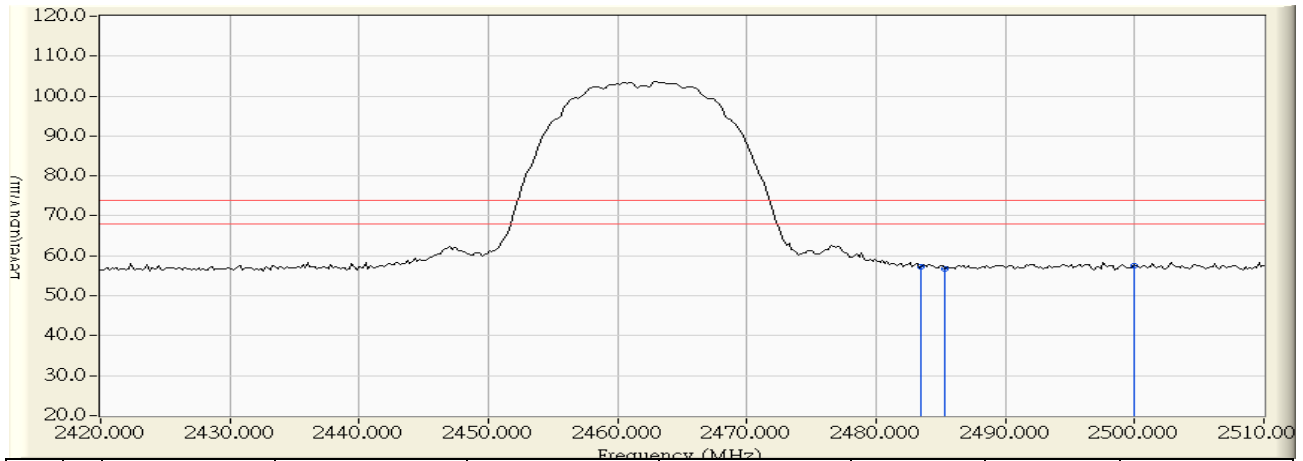

	Frequency (MHz)	Correct Factor (dB)	Reading Level (dBuV)	Measure Level (dBuV/m)	Margin (dB)	Limit (dBuV/m)	Detector Type
1	2483.500	31.512	25.882	57.394	-16.606	74.000	PEAK
2	2485.340	31.530	25.329	56.859	-17.141	74.000	PEAK
3	* 2500.000	31.638	25.974	57.613	-16.387	74.000	PEAK

Note:

1. All readings above 1GHz are performed with peak and/or average measurements as necessary.
2. Peak measurements: RBW = 1MHz, VBW = 3 MHz, Sweep: Auto.
3. Average measurements: RBW = 1MHz, VBW = 10 Hz, Sweep: Auto.
4. “ * ”, means this data is the worst emission level.
5. Measurement Level = Reading Level + Correct Factor.
6. The average measurement was not performed when the peak measured data under the limit of average detection.

Site : CB1	Time : 2011/10/27 - 13:07
Limit : FCC_SpartC_15.209_03M_AV	Margin : 6
Probe : EFS_1-18G-1_0901 - VERTICAL	Power : AC120V/60Hz
EUT : Wireless N Day/Night Internet Camera	Note : Mode 1: Transmit_2462MHz_802.11_b

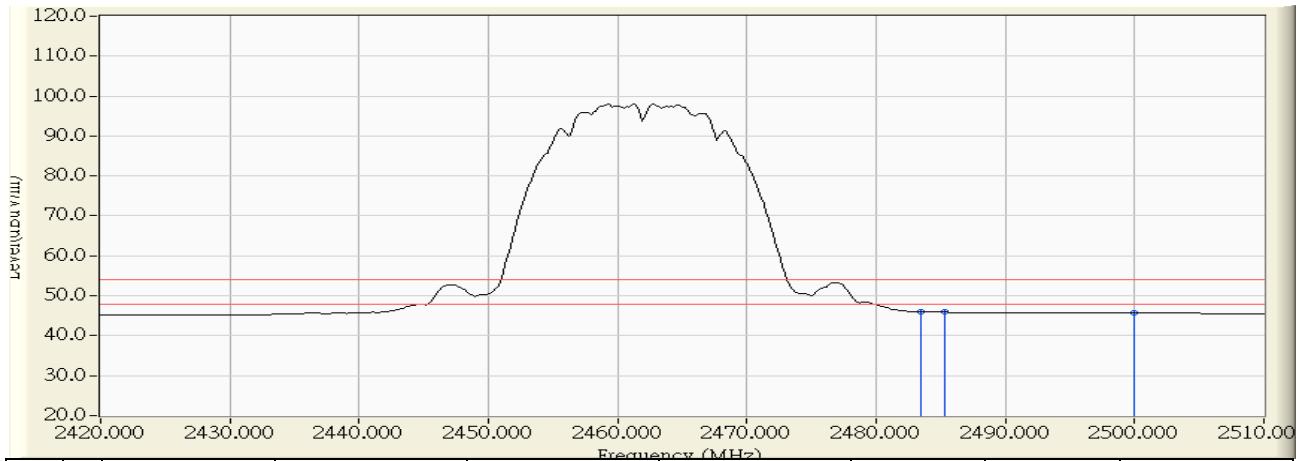

		Frequency (MHz)	Correct Factor (dB)	Reading Level (dBuV)	Measure Level (dBuV/m)	Margin (dB)	Limit (dBuV/m)	Detector Type
1	*	2483.500	31.512	14.487	45.999	-8.001	54.000	AVERAGE
2		2485.350	31.530	14.357	45.887	-8.113	54.000	AVERAGE
3		2500.000	31.638	14.101	45.740	-8.260	54.000	AVERAGE

Note:

1. All readings above 1GHz are performed with peak and/or average measurements as necessary.
2. Peak measurements: RBW = 1MHz, VBW = 3 MHz, Sweep: Auto.
3. Average measurements: RBW = 1MHz, VBW = 10 Hz, Sweep: Auto.
4. “ * ”, means this data is the worst emission level.
5. Measurement Level = Reading Level + Correct Factor.
6. The average measurement was not performed when the peak measured data under the limit of average detection.

Site : CB1	Time : 2011/10/27 - 11:25
Limit : FCC_SpartC_15.209_03M_PK	Margin : 6
Probe : EFS_1-18G-1_0901 - HORIZONTAL	Power : AC120V/60Hz
EUT : Wireless N Day/Night Internet Camera	Note : Mode 1: Transmit_2412MHz_802.11_g

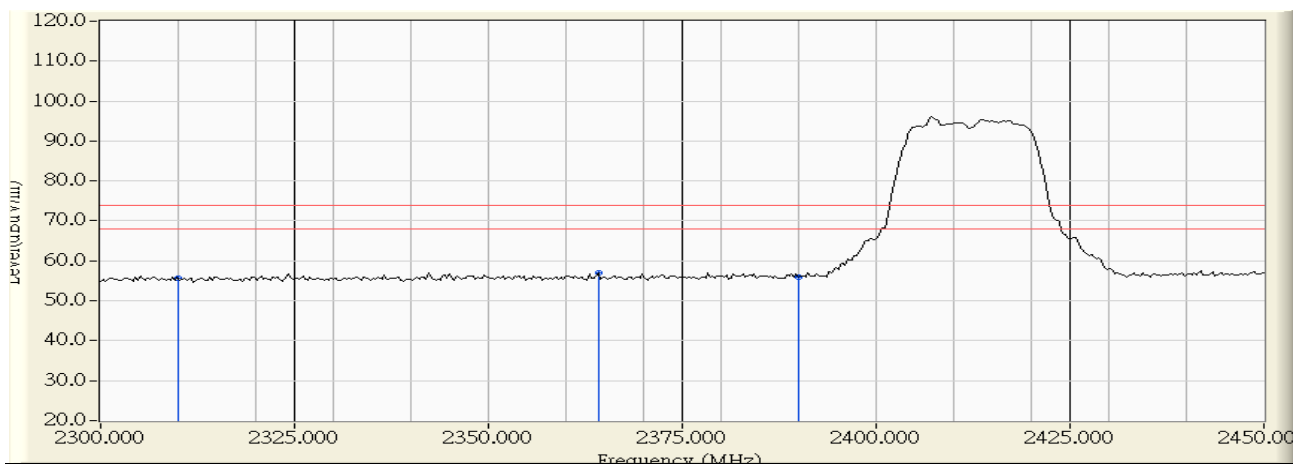

	Frequency (MHz)	Correct Factor (dB)	Reading Level (dBuV)	Measure Level (dBuV/m)	Margin (dB)	Limit (dBuV/m)	Detector Type
1	2310.000	29.779	25.928	55.707	-18.293	74.000	PEAK
2	* 2364.200	30.321	26.702	57.022	-16.978	74.000	PEAK
3	2390.000	30.578	25.301	55.879	-18.121	74.000	PEAK

Note:

1. All readings above 1GHz are performed with peak and/or average measurements as necessary.
2. Peak measurements: RBW = 1MHz, VBW = 3 MHz, Sweep: Auto.
3. Average measurements: RBW = 1MHz, VBW = 10 Hz, Sweep: Auto.
4. “ * ”, means this data is the worst emission level.
5. Measurement Level = Reading Level + Correct Factor.
6. The average measurement was not performed when the peak measured data under the limit of average detection.

Site : CB1	Time : 2011/10/27 - 11:26
Limit : FCC_SpartC_15.209_03M_AV	Margin : 6
Probe : EFS_1-18G-1_0901 - HORIZONTAL	Power : AC120V/60Hz
EUT : Wireless N Day/Night Internet Camera	Note : Mode 1: Transmit_2412MHz_802.11_g

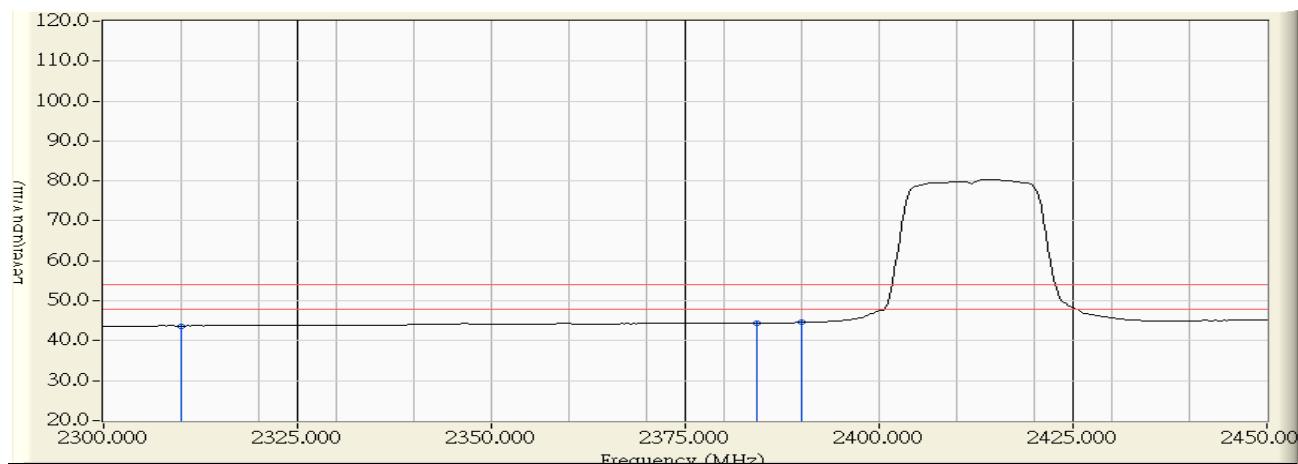

	Frequency (MHz)	Correct Factor (dB)	Reading Level (dBuV)	Measure Level (dBuV/m)	Margin (dB)	Limit (dBuV/m)	Detector Type
1	2310.000	29.779	13.941	43.720	-10.280	54.000	AVERAGE
2	2384.200	30.520	13.938	44.458	-9.542	54.000	AVERAGE
3	* 2390.000	30.578	13.974	44.552	-9.448	54.000	AVERAGE

Note:

1. All readings above 1GHz are performed with peak and/or average measurements as necessary.
2. Peak measurements: RBW = 1MHz, VBW = 3 MHz, Sweep: Auto.
3. Average measurements: RBW = 1MHz, VBW = 10 Hz, Sweep: Auto.
4. “ * ”, means this data is the worst emission level.
5. Measurement Level = Reading Level + Correct Factor.
6. The average measurement was not performed when the peak measured data under the limit of average detection.

Site : CB1	Time : 2011/10/27 - 11:33
Limit : FCC_SpartC_15.209_03M_PK	Margin : 6
Probe : EFS_1-18G-1_0901 - VERTICAL	Power : AC120V/60Hz
EUT : Wireless N Day/Night Internet Camera	Note : Mode 1: Transmit_2412MHz_802.11_g

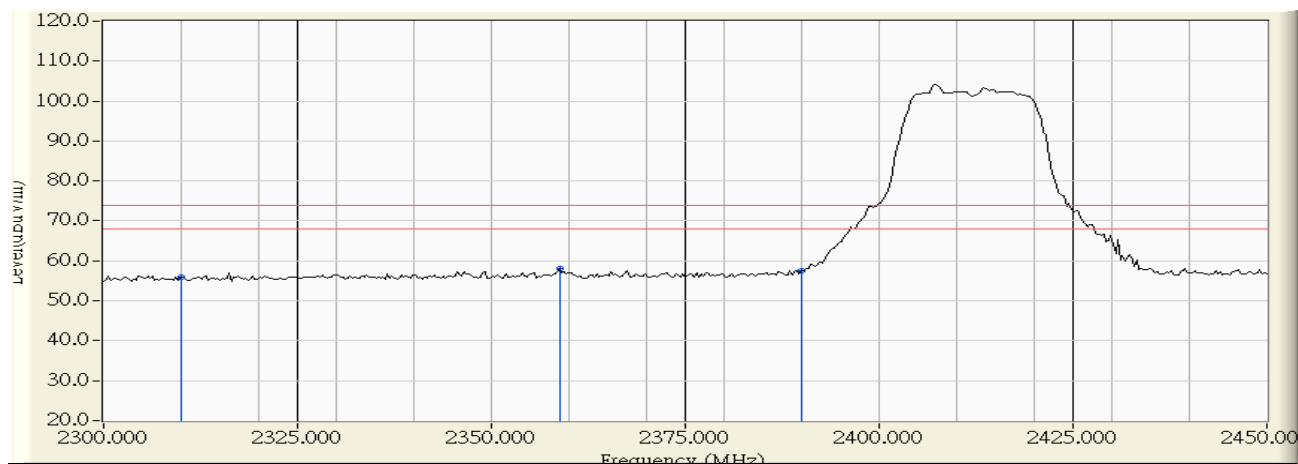

	Frequency (MHz)	Correct Factor (dB)	Reading Level (dBuV)	Measure Level (dBuV/m)	Margin (dB)	Limit (dBuV/m)	Detector Type
1	2310.000	29.779	26.085	55.864	-18.136	74.000	PEAK
2	* 2358.800	30.266	27.798	58.064	-15.936	74.000	PEAK
3	2390.000	30.578	27.007	57.585	-16.415	74.000	PEAK

Note:

1. All readings above 1GHz are performed with peak and/or average measurements as necessary.
2. Peak measurements: RBW = 1MHz, VBW = 3 MHz, Sweep: Auto.
3. Average measurements: RBW = 1MHz, VBW = 10 Hz, Sweep: Auto.
4. “ * ”, means this data is the worst emission level.
5. Measurement Level = Reading Level + Correct Factor.
6. The average measurement was not performed when the peak measured data under the limit of average detection.

Site : CB1	Time : 2011/10/27 - 11:34
Limit : FCC_SpartC_15.209_03M_AV	Margin : 6
Probe : EFS_1-18G-1_0901 - VERTICAL	Power : AC120V/60Hz
EUT : Wireless N Day/Night Internet Camera	Note : Mode 1: Transmit_2412MHz_802.11_g

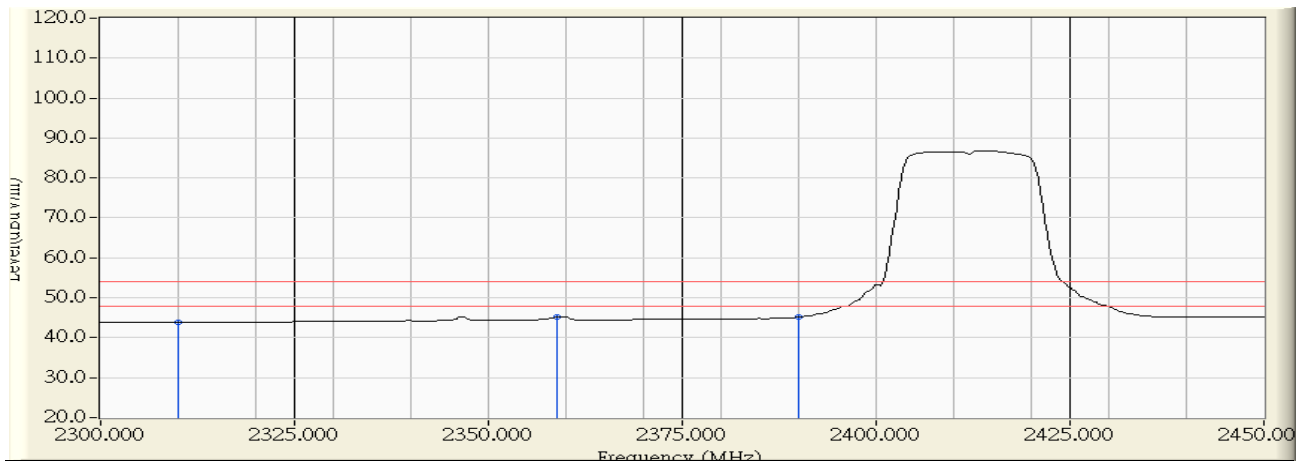

	Frequency (MHz)	Correct Factor (dB)	Reading Level (dBuV)	Measure Level (dBuV/m)	Margin (dB)	Limit (dBuV/m)	Detector Type
1	2310.000	29.779	14.031	43.810	-10.190	54.000	AVERAGE
2	2358.800	30.266	14.818	45.084	-8.916	54.000	AVERAGE
3	* 2390.000	30.578	14.606	45.184	-8.816	54.000	AVERAGE

Note:

1. All readings above 1GHz are performed with peak and/or average measurements as necessary.
2. Peak measurements: RBW = 1MHz, VBW = 3 MHz, Sweep: Auto.
3. Average measurements: RBW = 1MHz, VBW = 10 Hz, Sweep: Auto.
4. “ * ”, means this data is the worst emission level.
5. Measurement Level = Reading Level + Correct Factor.
6. The average measurement was not performed when the peak measured data under the limit of average detection.

Site : CB1	Time : 2011/10/27 - 13:10
Limit : FCC_SpartC_15.209_03M_PK	Margin : 6
Probe : EFS_1-18G-1_0901 - HORIZONTAL	Power : AC120V/60Hz
EUT : Wireless N Day/Night Internet Camera	Note : Mode 1: Transmit_2462MHz_802.11_g

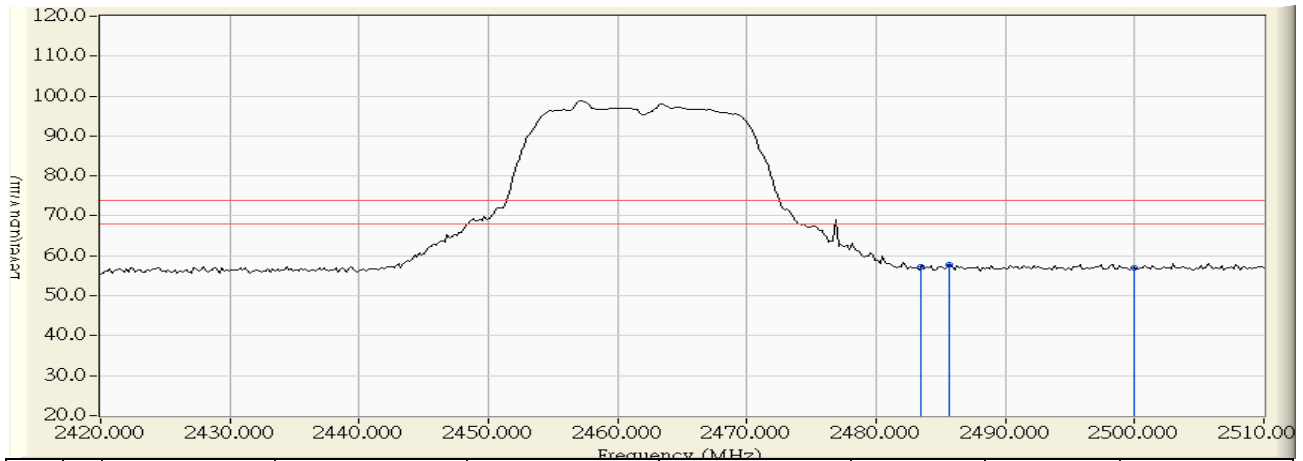

	Frequency (MHz)	Correct Factor (dB)	Reading Level (dBuV)	Measure Level (dBuV/m)	Margin (dB)	Limit (dBuV/m)	Detector Type
1	2483.500	31.512	25.768	57.280	-16.720	74.000	PEAK
2	* 2485.700	31.533	26.371	57.905	-16.095	74.000	PEAK
3	2500.000	31.638	25.404	57.043	-16.957	74.000	PEAK

Note:

1. All readings above 1GHz are performed with peak and/or average measurements as necessary.
2. Peak measurements: RBW = 1MHz, VBW = 3 MHz, Sweep: Auto.
3. Average measurements: RBW = 1MHz, VBW = 10 Hz, Sweep: Auto.
4. “ * ”, means this data is the worst emission level.
5. Measurement Level = Reading Level + Correct Factor.
6. The average measurement was not performed when the peak measured data under the limit of average detection.

Site : CB1	Time : 2011/10/27 - 13:11
Limit : FCC_SpartC_15.209_03M_AV	Margin : 6
Probe : EFS_1-18G-1_0901 - HORIZONTAL	Power : AC120V/60Hz
EUT : Wireless N Day/Night Internet Camera	Note : Mode 1: Transmit_2462MHz_802.11_g

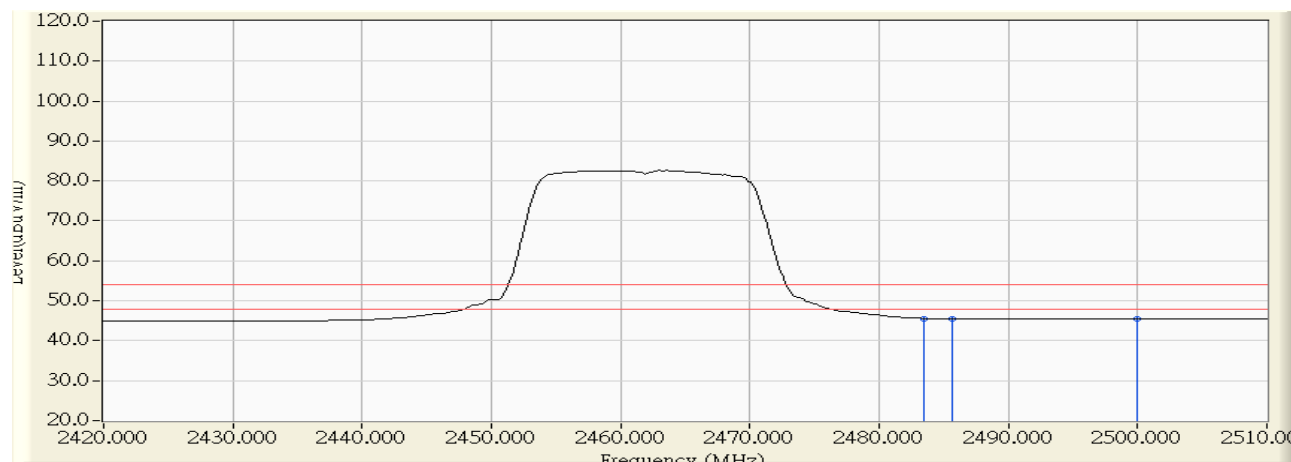

		Frequency (MHz)	Correct Factor (dB)	Reading Level (dBuV)	Measure Level (dBuV/m)	Margin (dB)	Limit (dBuV/m)	Detector Type
1	*	2483.500	31.512	14.060	45.572	-8.428	54.000	AVERAGE
2		2485.700	31.533	13.966	45.500	-8.500	54.000	AVERAGE
3		2500.000	31.638	13.858	45.497	-8.503	54.000	AVERAGE

Note:

1. All readings above 1GHz are performed with peak and/or average measurements as necessary.
2. Peak measurements: RBW = 1MHz, VBW = 3 MHz, Sweep: Auto.
3. Average measurements: RBW = 1MHz, VBW = 10 Hz, Sweep: Auto.
4. “ * ”, means this data is the worst emission level.
5. Measurement Level = Reading Level + Correct Factor.
6. The average measurement was not performed when the peak measured data under the limit of average detection.

Site : CB1	Time : 2011/10/27 - 13:14
Limit : FCC_SpartC_15.209_03M_PK	Margin : 6
Probe : EFS_1-18G-1_0901 - VERTICAL	Power : AC120V/60Hz
EUT : Wireless N Day/Night Internet Camera	Note : Mode 1: Transmit_2462MHz_802.11_g

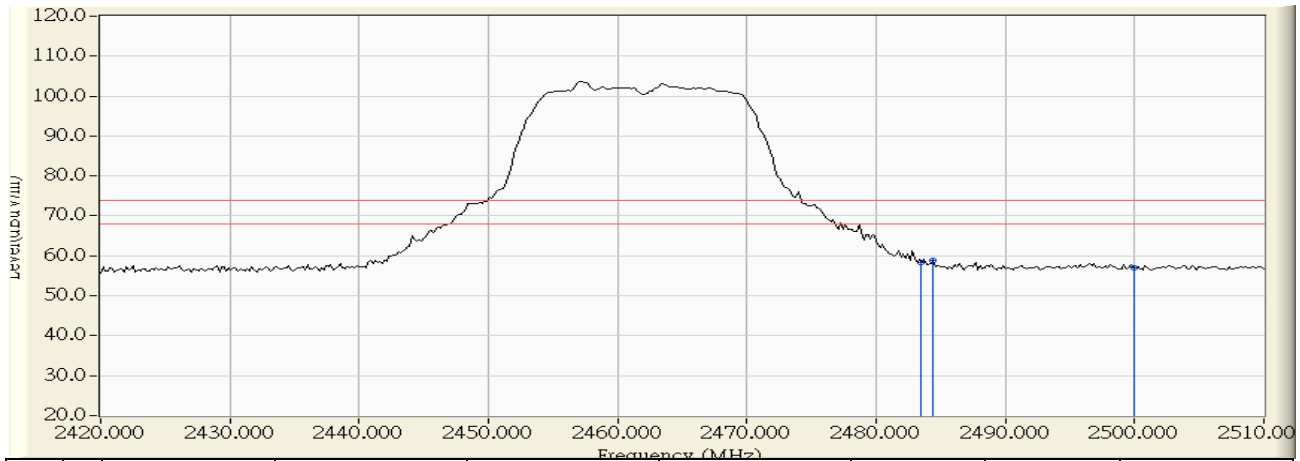

	Frequency (MHz)	Correct Factor (dB)	Reading Level (dBuV)	Measure Level (dBuV/m)	Margin (dB)	Limit (dBuV/m)	Detector Type
1	2483.500	31.512	26.925	58.437	-15.563	74.000	PEAK
2	* 2484.440	31.521	27.237	58.758	-15.242	74.000	PEAK
3	2500.000	31.638	25.416	57.055	-16.945	74.000	PEAK

Note:

1. All readings above 1GHz are performed with peak and/or average measurements as necessary.
2. Peak measurements: RBW = 1MHz, VBW = 3 MHz, Sweep: Auto.
3. Average measurements: RBW = 1MHz, VBW = 10 Hz, Sweep: Auto.
4. “ * ”, means this data is the worst emission level.
5. Measurement Level = Reading Level + Correct Factor.
6. The average measurement was not performed when the peak measured data under the limit of average detection.

Site : CB1	Time : 2011/10/27 - 13:15
Limit : FCC_SpartC_15.209_03M_AV	Margin : 6
Probe : EFS_1-18G-1_0901 - VERTICAL	Power : AC120V/60Hz
EUT : Wireless N Day/Night Internet Camera	Note : Mode 1: Transmit_2462MHz_802.11_g

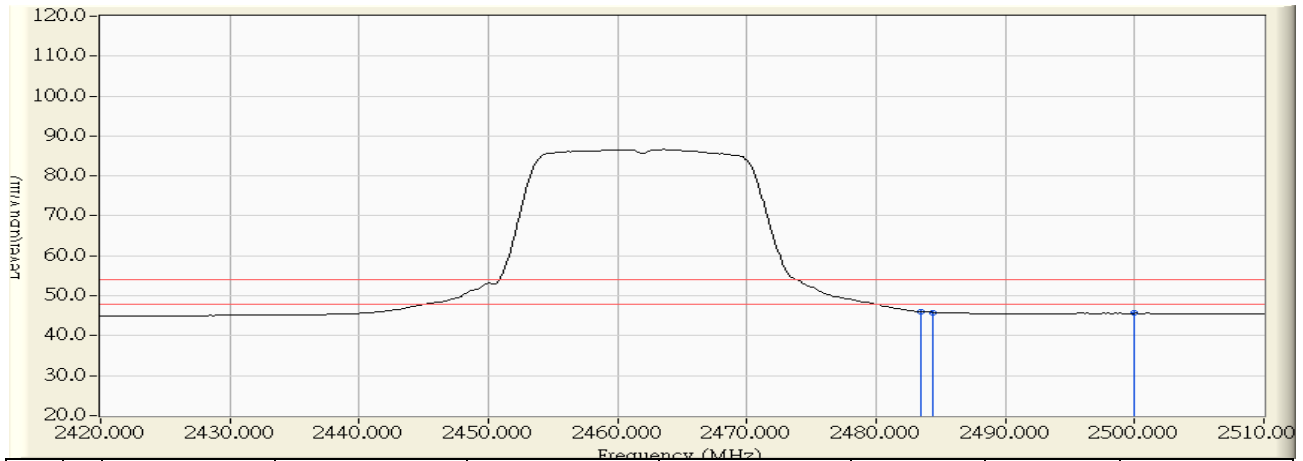

		Frequency (MHz)	Correct Factor (dB)	Reading Level (dBuV)	Measure Level (dBuV/m)	Margin (dB)	Limit (dBuV/m)	Detector Type
1	*	2483.500	31.512	14.503	46.015	-7.985	54.000	AVERAGE
2		2484.440	31.521	14.331	45.852	-8.148	54.000	AVERAGE
3		2500.000	31.638	13.968	45.607	-8.393	54.000	AVERAGE

Note:

1. All readings above 1GHz are performed with peak and/or average measurements as necessary.
2. Peak measurements: RBW = 1MHz, VBW = 3 MHz, Sweep: Auto.
3. Average measurements: RBW = 1MHz, VBW = 10 Hz, Sweep: Auto.
4. “ * ”, means this data is the worst emission level.
5. Measurement Level = Reading Level + Correct Factor.
6. The average measurement was not performed when the peak measured data under the limit of average detection.

Site : CB1	Time : 2011/10/27 - 11:38
Limit : FCC_SpartC_15.209_03M_PK	Margin : 6
Probe : EFS_1-18G-1_0901 - HORIZONTAL	Power : AC120V/60Hz
EUT : Wireless N Day/Night Internet Camera	Note : Mode 1: Transmit_2412MHz_802.11_n(20MHz)

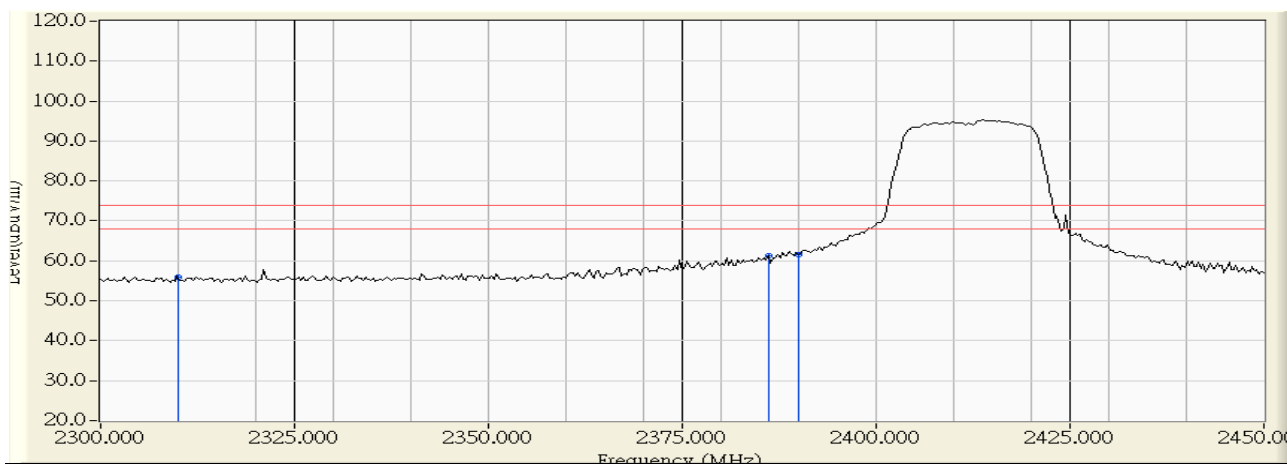

	Frequency (MHz)	Correct Factor (dB)	Reading Level (dBuV)	Measure Level (dBuV/m)	Margin (dB)	Limit (dBuV/m)	Detector Type
1	2310.000	29.779	26.087	55.866	-18.134	74.000	PEAK
2	2386.100	30.539	30.669	61.208	-12.792	74.000	PEAK
3	* 2390.000	30.578	30.991	61.569	-12.431	74.000	PEAK

Note:

1. All readings above 1GHz are performed with peak and/or average measurements as necessary.
2. Peak measurements: RBW = 1MHz, VBW = 3 MHz, Sweep: Auto.
3. Average measurements: RBW = 1MHz, VBW = 10 Hz, Sweep: Auto.
4. “ * ”, means this data is the worst emission level.
5. Measurement Level = Reading Level + Correct Factor.
6. The average measurement was not performed when the peak measured data under the limit of average detection.

Site : CB1	Time : 2011/10/27 - 11:40
Limit : FCC_SpartC_15.209_03M_AV	Margin : 6
Probe : EFS_1-18G-1_0901 - HORIZONTAL	Power : AC120V/60Hz
EUT : Wireless N Day/Night Internet Camera	Note : Mode 1: Transmit_2412MHz_802.11_n(20MHz)

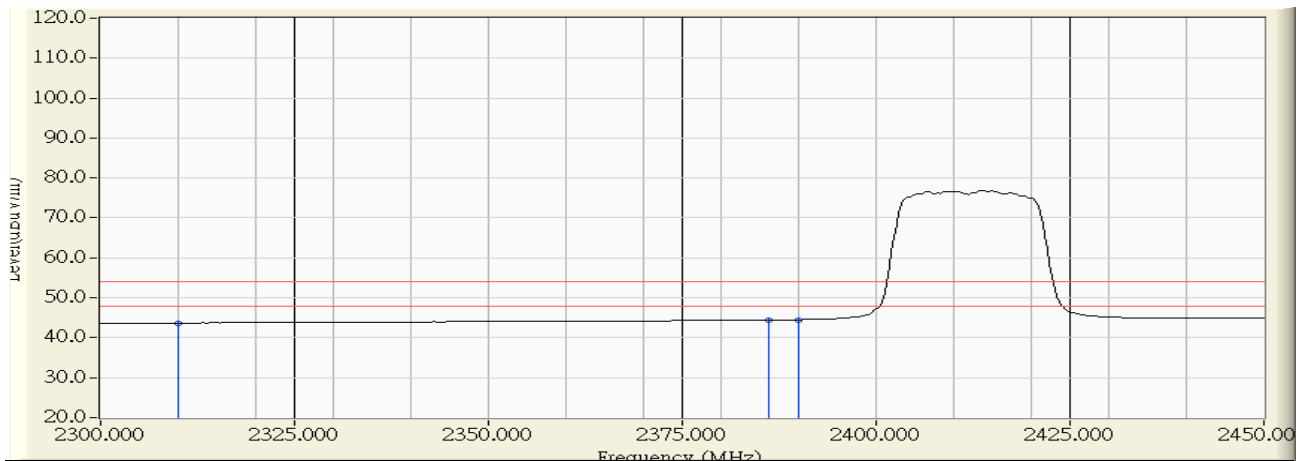

	Frequency (MHz)	Correct Factor (dB)	Reading Level (dBuV)	Measure Level (dBuV/m)	Margin (dB)	Limit (dBuV/m)	Detector Type
1	2310.000	29.779	13.914	43.693	-10.307	54.000	AVERAGE
2	2386.100	30.539	13.877	44.416	-9.584	54.000	AVERAGE
3	* 2390.000	30.578	13.925	44.503	-9.497	54.000	AVERAGE

Note:

1. All readings above 1GHz are performed with peak and/or average measurements as necessary.
2. Peak measurements: RBW = 1MHz, VBW = 3 MHz, Sweep: Auto.
3. Average measurements: RBW = 1MHz, VBW = 10 Hz, Sweep: Auto.
4. “ * ”, means this data is the worst emission level.
5. Measurement Level = Reading Level + Correct Factor.
6. The average measurement was not performed when the peak measured data under the limit of average detection.

Site : CB1	Time : 2011/10/27 - 11:43
Limit : FCC_SpartC_15.209_03M_PK	Margin : 6
Probe : EFS_1-18G-1_0901 - VERTICAL	Power : AC120V/60Hz
EUT : Wireless N Day/Night Internet Camera	Note : Mode 1: Transmit_2412MHz_802.11_n(20MHz)

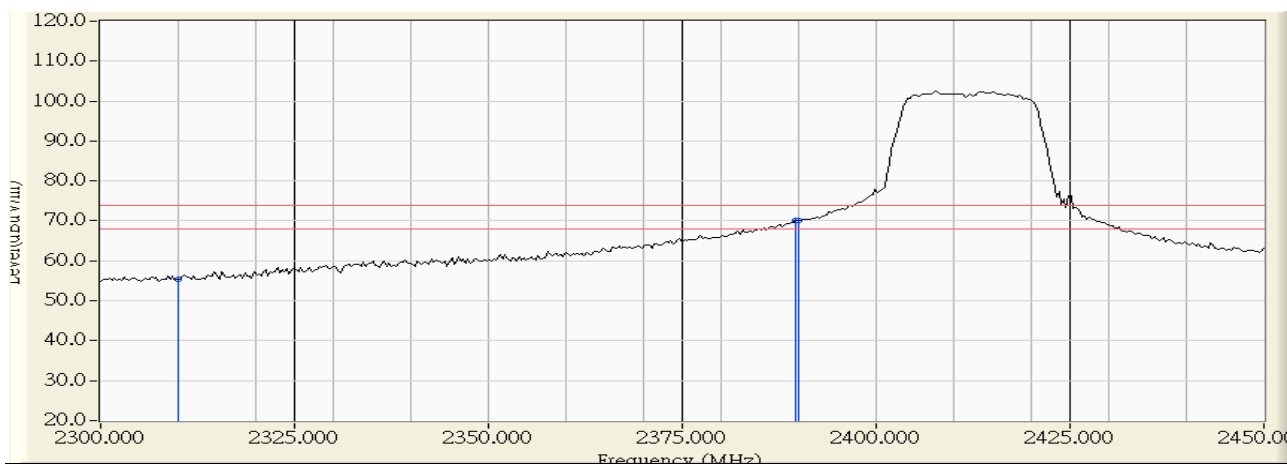

	Frequency (MHz)	Correct Factor (dB)	Reading Level (dBuV)	Measure Level (dBuV/m)	Margin (dB)	Limit (dBuV/m)	Detector Type
1	2310.000	29.779	25.647	55.426	-18.574	74.000	PEAK
2	2389.700	30.575	39.612	70.187	-3.813	74.000	PEAK
3	* 2390.000	30.578	39.679	70.257	-3.743	74.000	PEAK

Note:

1. All readings above 1GHz are performed with peak and/or average measurements as necessary.
2. Peak measurements: RBW = 1MHz, VBW = 3 MHz, Sweep: Auto.
3. Average measurements: RBW = 1MHz, VBW = 10 Hz, Sweep: Auto.
4. “ * ”, means this data is the worst emission level.
5. Measurement Level = Reading Level + Correct Factor.
6. The average measurement was not performed when the peak measured data under the limit of average detection.

Site : CB1	Time : 2011/10/27 - 11:44
Limit : FCC_SpartC_15.209_03M_AV	Margin : 6
Probe : EFS_1-18G-1_0901 - VERTICAL	Power : AC120V/60Hz
EUT : Wireless N Day/Night Internet Camera	Note : Mode 1: Transmit_2412MHz_802.11_n(20MHz)

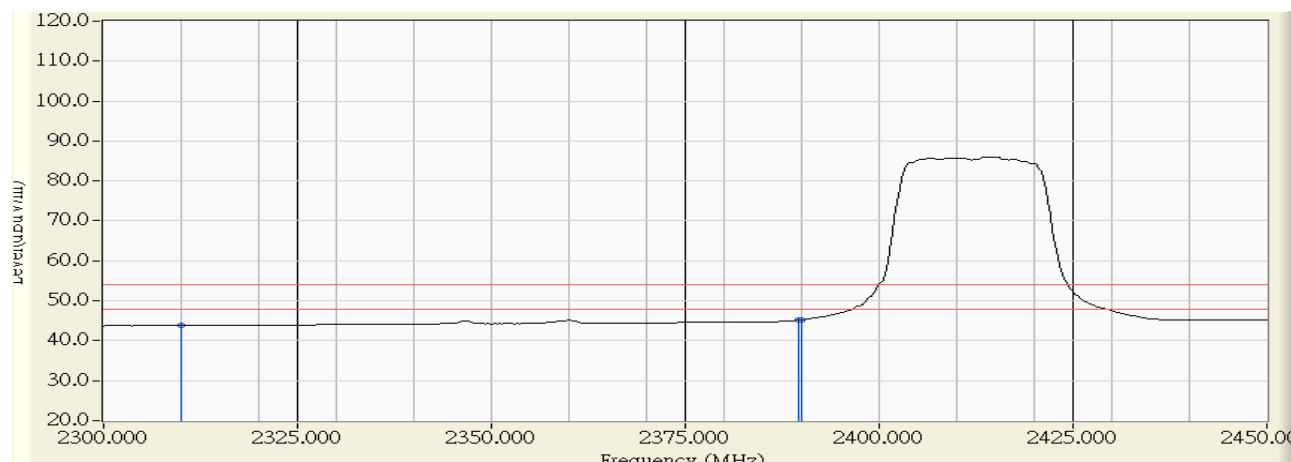

	Frequency (MHz)	Correct Factor (dB)	Reading Level (dBuV)	Measure Level (dBuV/m)	Margin (dB)	Limit (dBuV/m)	Detector Type
1	2310.000	29.779	14.010	43.789	-10.211	54.000	AVERAGE
2	2389.700	30.575	14.579	45.154	-8.846	54.000	AVERAGE
3	* 2390.000	30.578	14.646	45.224	-8.776	54.000	AVERAGE

Note:

1. All readings above 1GHz are performed with peak and/or average measurements as necessary.
2. Peak measurements: RBW = 1MHz, VBW = 3 MHz, Sweep: Auto.
3. Average measurements: RBW = 1MHz, VBW = 10 Hz, Sweep: Auto.
4. “ * ”, means this data is the worst emission level.
5. Measurement Level = Reading Level + Correct Factor.
6. The average measurement was not performed when the peak measured data under the limit of average detection.

Site : CB1	Time : 2011/10/27 - 13:18
Limit : FCC_SpartC_15.209_03M_PK	Margin : 6
Probe : EFS_1-18G-1_0901 - HORIZONTAL	Power : AC120V/60Hz
EUT : Wireless N Day/Night Internet Camera	Note : Mode 1: Transmit_2462MHz_802.11_n(20MHz)

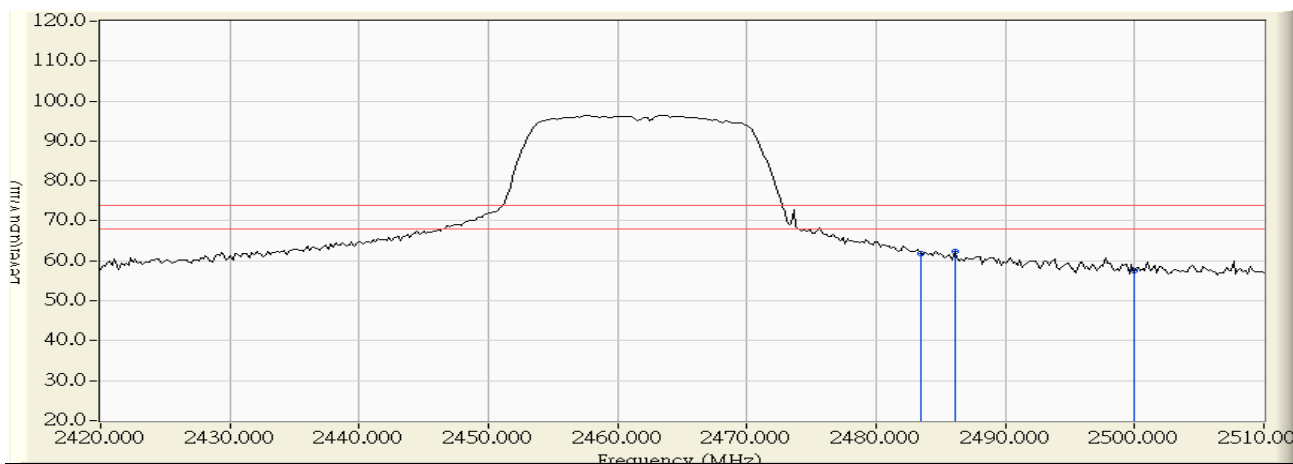

	Frequency (MHz)	Correct Factor (dB)	Reading Level (dBuV)	Measure Level (dBuV/m)	Margin (dB)	Limit (dBuV/m)	Detector Type
1	2483.500	31.512	30.320	61.832	-12.168	74.000	PEAK
2	* 2486.060	31.538	30.752	62.289	-11.711	74.000	PEAK
3	2500.000	31.638	25.894	57.533	-16.467	74.000	PEAK

Note:

1. All readings above 1GHz are performed with peak and/or average measurements as necessary.
2. Peak measurements: RBW = 1MHz, VBW = 3 MHz, Sweep: Auto.
3. Average measurements: RBW = 1MHz, VBW = 10 Hz, Sweep: Auto.
4. “ * ”, means this data is the worst emission level.
5. Measurement Level = Reading Level + Correct Factor.
6. The average measurement was not performed when the peak measured data under the limit of average detection.

Site : CB1	Time : 2011/10/27 - 13:19
Limit : FCC_SpartC_15.209_03M_AV	Margin : 6
Probe : EFS_1-18G-1_0901 - HORIZONTAL	Power : AC120V/60Hz
EUT : Wireless N Day/Night Internet Camera	Note : Mode 1: Transmit_2462MHz_802.11_n(20MHz)

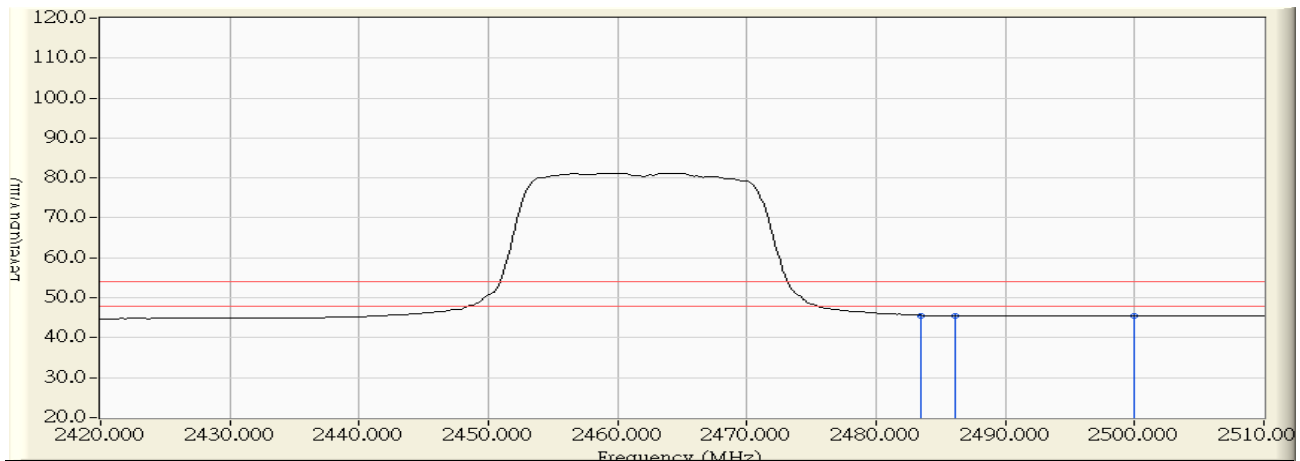

		Frequency (MHz)	Correct Factor (dB)	Reading Level (dBuV)	Measure Level (dBuV/m)	Margin (dB)	Limit (dBuV/m)	Detector Type
1	*	2483.500	31.512	14.087	45.599	-8.401	54.000	AVERAGE
2		2486.060	31.538	13.926	45.463	-8.537	54.000	AVERAGE
3		2500.000	31.638	13.743	45.382	-8.618	54.000	AVERAGE

Note:

1. All readings above 1GHz are performed with peak and/or average measurements as necessary.
2. Peak measurements: RBW = 1MHz, VBW = 3 MHz, Sweep: Auto.
3. Average measurements: RBW = 1MHz, VBW = 10 Hz, Sweep: Auto.
4. “ * ”, means this data is the worst emission level.
5. Measurement Level = Reading Level + Correct Factor.
6. The average measurement was not performed when the peak measured data under the limit of average detection.

Site : CB1	Time : 2011/10/27 - 13:22
Limit : FCC_SpartC_15.209_03M_PK	Margin : 6
Probe : EFS_1-18G-1_0901 - VERTICAL	Power : AC120V/60Hz
EUT : Wireless N Day/Night Internet Camera	Note : Mode 1: Transmit_2462MHz_802.11_n(20MHz)

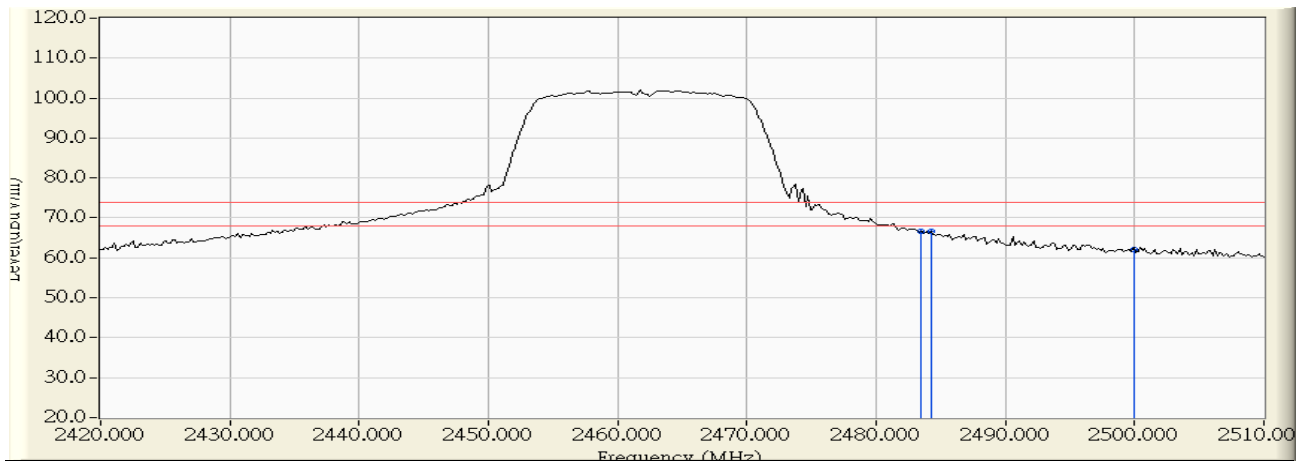

	Frequency (MHz)	Correct Factor (dB)	Reading Level (dBuV)	Measure Level (dBuV/m)	Margin (dB)	Limit (dBuV/m)	Detector Type
1	2483.500	31.512	35.036	66.548	-7.452	74.000	PEAK
2	* 2484.260	31.519	35.087	66.606	-7.394	74.000	PEAK
3	2500.000	31.638	30.375	62.014	-11.986	74.000	PEAK

Note:

1. All readings above 1GHz are performed with peak and/or average measurements as necessary.
2. Peak measurements: RBW = 1MHz, VBW = 3 MHz, Sweep: Auto.
3. Average measurements: RBW = 1MHz, VBW = 10 Hz, Sweep: Auto.
4. “ * ”, means this data is the worst emission level.
5. Measurement Level = Reading Level + Correct Factor.
6. The average measurement was not performed when the peak measured data under the limit of average detection.

Site : CB1	Time : 2011/10/27 - 13:23
Limit : FCC_SpartC_15.209_03M_AV	Margin : 6
Probe : EFS_1-18G-1_0901 - VERTICAL	Power : AC120V/60Hz
EUT : Wireless N Day/Night Internet Camera	Note : Mode 1: Transmit_2462MHz_802.11_n(20MHz)

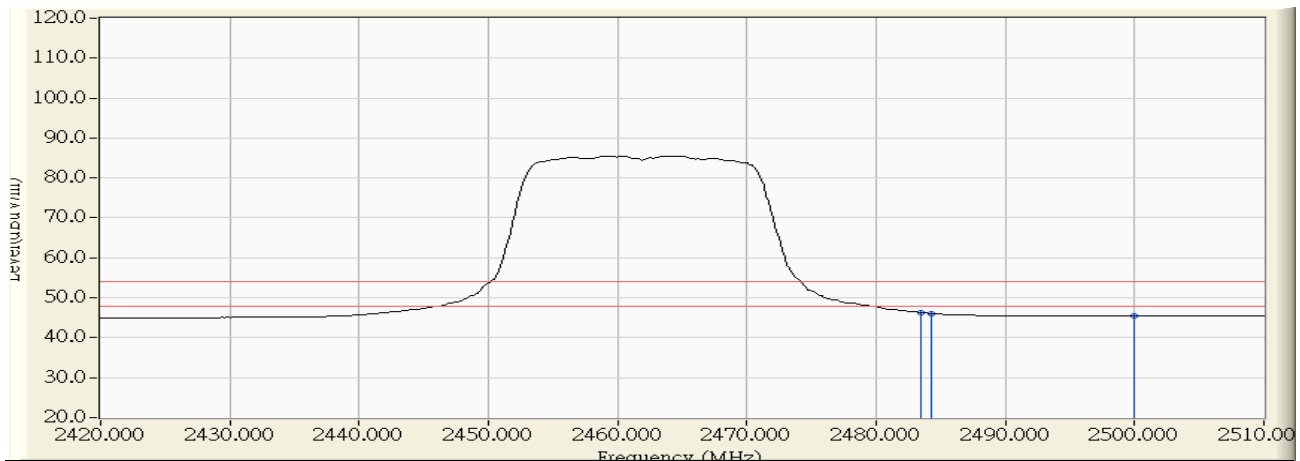

		Frequency (MHz)	Correct Factor (dB)	Reading Level (dBuV)	Measure Level (dBuV/m)	Margin (dB)	Limit (dBuV/m)	Detector Type
1	*	2483.500	31.512	14.752	46.264	-7.736	54.000	AVERAGE
2		2484.260	31.519	14.522	46.041	-7.959	54.000	AVERAGE
3		2500.000	31.638	13.736	45.375	-8.625	54.000	AVERAGE

Note:

1. All readings above 1GHz are performed with peak and/or average measurements as necessary.
2. Peak measurements: RBW = 1MHz, VBW = 3 MHz, Sweep: Auto.
3. Average measurements: RBW = 1MHz, VBW = 10 Hz, Sweep: Auto.
4. “ * ”, means this data is the worst emission level.
5. Measurement Level = Reading Level + Correct Factor.
6. The average measurement was not performed when the peak measured data under the limit of average detection.

Site : CB1	Time : 2011/10/27 - 11:49
Limit : FCC_SpartC_15.209_03M_PK	Margin : 6
Probe : EFS_1-18G-1_0901 - HORIZONTAL	Power : AC120V/60Hz
EUT : Wireless N Day/Night Internet Camera	Note : Mode 1: Transmit_2422MHz_802.11_n(40MHz)

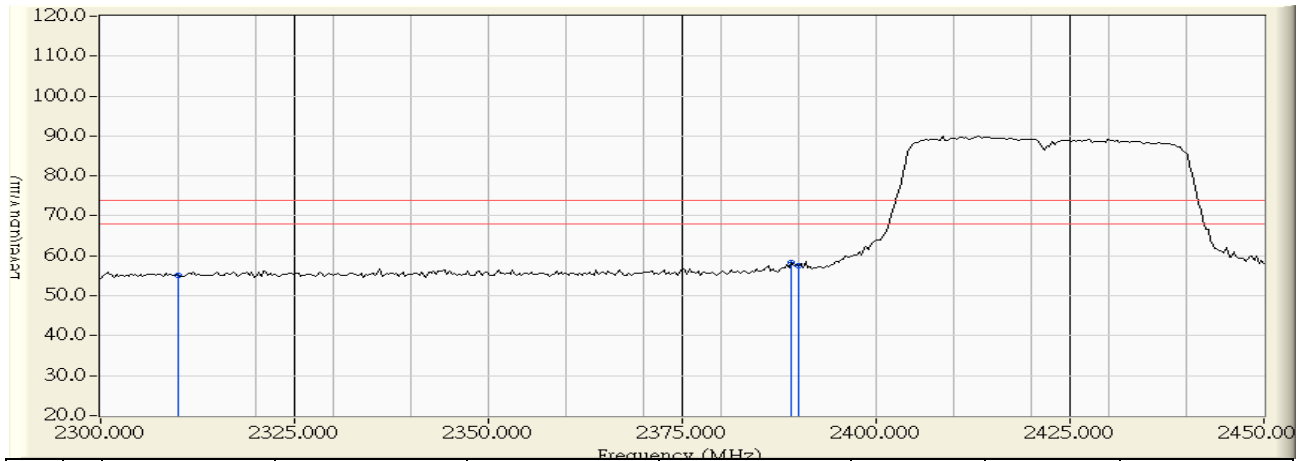

	Frequency (MHz)	Correct Factor (dB)	Reading Level (dBuV)	Measure Level (dBuV/m)	Margin (dB)	Limit (dBuV/m)	Detector Type
1	2310.000	29.779	25.434	55.213	-18.787	74.000	PEAK
2	* 2389.100	30.569	27.711	58.280	-15.720	74.000	PEAK
3	2390.000	30.578	26.871	57.449	-16.551	74.000	PEAK

Note:

1. All readings above 1GHz are performed with peak and/or average measurements as necessary.
2. Peak measurements: RBW = 1MHz, VBW = 3 MHz, Sweep: Auto.
3. Average measurements: RBW = 1MHz, VBW = 10 Hz, Sweep: Auto.
4. “ * ”, means this data is the worst emission level.
5. Measurement Level = Reading Level + Correct Factor.
6. The average measurement was not performed when the peak measured data under the limit of average detection.

Site : CB1	Time : 2011/10/27 - 11:50
Limit : FCC_SpartC_15.209_03M_AV	Margin : 6
Probe : EFS_1-18G-1_0901 - HORIZONTAL	Power : AC120V/60Hz
EUT : Wireless N Day/Night Internet Camera	Note : Mode 1: Transmit_2422MHz_802.11_n(40MHz)

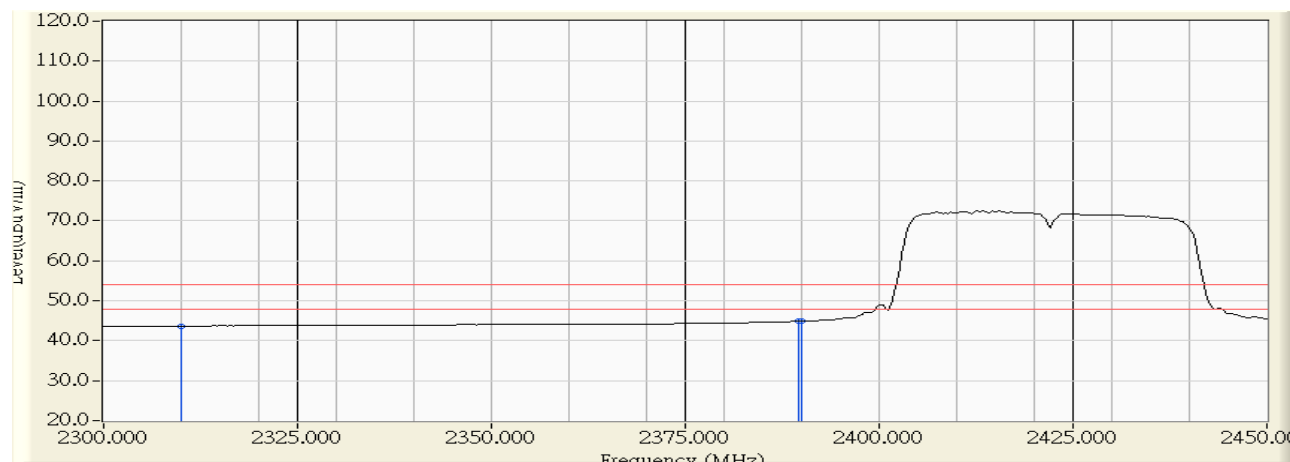

	Frequency (MHz)	Correct Factor (dB)	Reading Level (dBuV)	Measure Level (dBuV/m)	Margin (dB)	Limit (dBuV/m)	Detector Type
1	2310.000	29.779	13.893	43.672	-10.328	54.000	AVERAGE
2	2389.700	30.575	14.336	44.911	-9.089	54.000	AVERAGE
3	* 2390.000	30.578	14.345	44.923	-9.077	54.000	AVERAGE

Note:

1. All readings above 1GHz are performed with peak and/or average measurements as necessary.
2. Peak measurements: RBW = 1MHz, VBW = 3 MHz, Sweep: Auto.
3. Average measurements: RBW = 1MHz, VBW = 10 Hz, Sweep: Auto.
4. “ * ”, means this data is the worst emission level.
5. Measurement Level = Reading Level + Correct Factor.
6. The average measurement was not performed when the peak measured data under the limit of average detection.

Site : CB1	Time : 2011/10/27 - 11:53
Limit : FCC_SpartC_15.209_03M_PK	Margin : 6
Probe : EFS_1-18G-1_0901 - VERTICAL	Power : AC120V/60Hz
EUT : Wireless N Day/Night Internet Camera	Note : Mode 1: Transmit_2422MHz_802.11_n(40MHz)

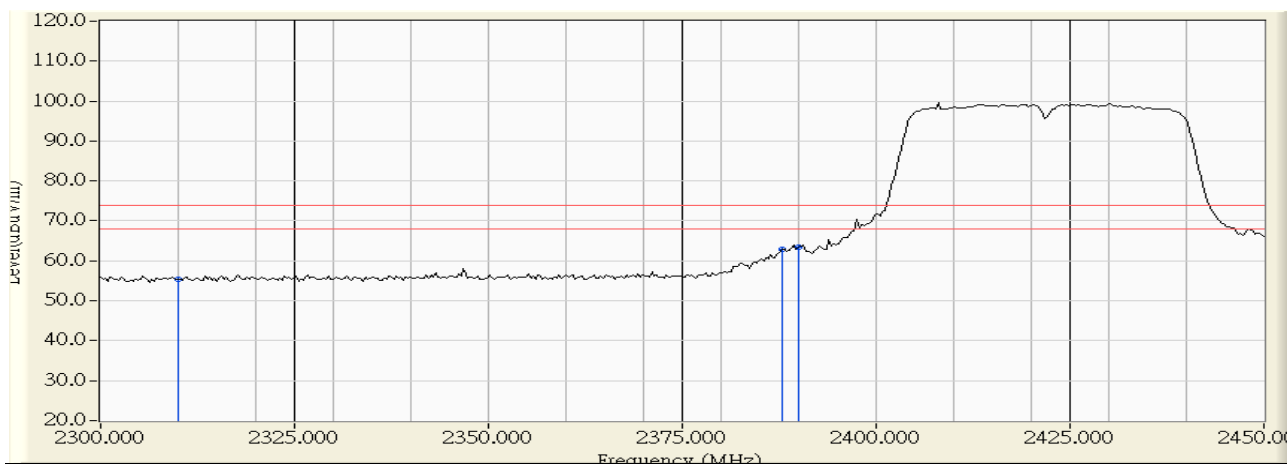

	Frequency (MHz)	Correct Factor (dB)	Reading Level (dBuV)	Measure Level (dBuV/m)	Margin (dB)	Limit (dBuV/m)	Detector Type
1	2310.000	29.779	25.558	55.337	-18.663	74.000	PEAK
2	2387.900	30.557	32.406	62.963	-11.037	74.000	PEAK
3	* 2390.000	30.578	32.917	63.495	-10.505	74.000	PEAK

Note:

1. All readings above 1GHz are performed with peak and/or average measurements as necessary.
2. Peak measurements: RBW = 1MHz, VBW = 3 MHz, Sweep: Auto.
3. Average measurements: RBW = 1MHz, VBW = 10 Hz, Sweep: Auto.
4. “ * ”, means this data is the worst emission level.
5. Measurement Level = Reading Level + Correct Factor.
6. The average measurement was not performed when the peak measured data under the limit of average detection.

Site : CB1	Time : 2011/10/27 - 11:54
Limit : FCC_SpartC_15.209_03M_AV	Margin : 6
Probe : EFS_1-18G-1_0901 - VERTICAL	Power : AC120V/60Hz
EUT : Wireless N Day/Night Internet Camera	Note : Mode 1: Transmit_2422MHz_802.11_n(40MHz)

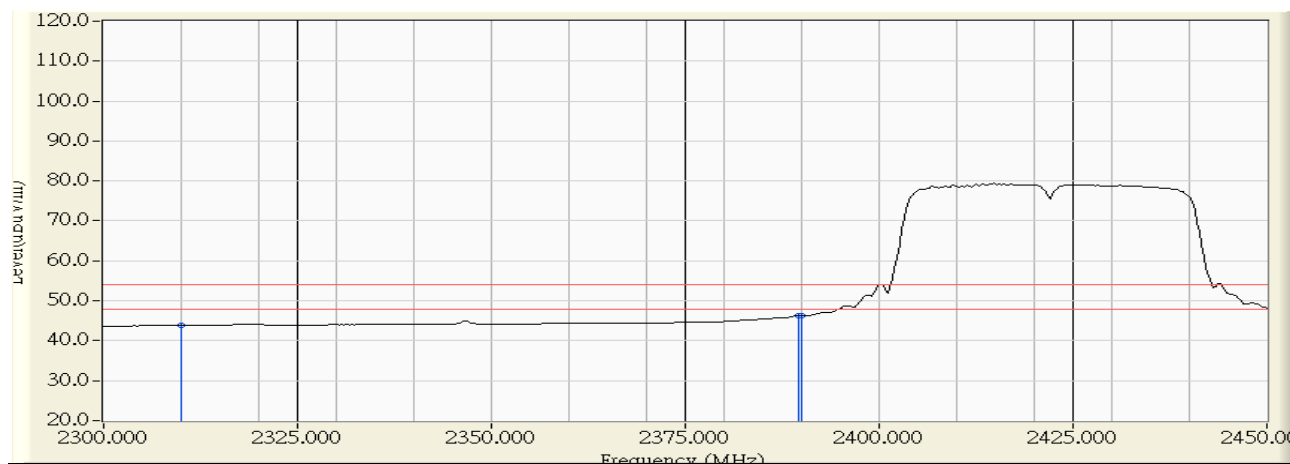

	Frequency (MHz)	Correct Factor (dB)	Reading Level (dBuV)	Measure Level (dBuV/m)	Margin (dB)	Limit (dBuV/m)	Detector Type
1	2310.000	29.779	14.019	43.798	-10.202	54.000	AVERAGE
2	* 2389.700	30.575	15.802	46.377	-7.623	54.000	AVERAGE
3	2390.000	30.578	15.789	46.367	-7.633	54.000	AVERAGE

Note:

1. All readings above 1GHz are performed with peak and/or average measurements as necessary.
2. Peak measurements: RBW = 1MHz, VBW = 3 MHz, Sweep: Auto.
3. Average measurements: RBW = 1MHz, VBW = 10 Hz, Sweep: Auto.
4. “ * ”, means this data is the worst emission level.
5. Measurement Level = Reading Level + Correct Factor.
6. The average measurement was not performed when the peak measured data under the limit of average detection.

Site : CB1	Time : 2011/10/27 - 13:27
Limit : FCC_SpartC_15.209_03M_PK	Margin : 6
Probe : EFS_1-18G-1_0901 - HORIZONTAL	Power : AC120V/60Hz
EUT : Wireless N Day/Night Internet Camera	Note : Mode 1: Transmit_2452MHz_802.11_n(40MHz)

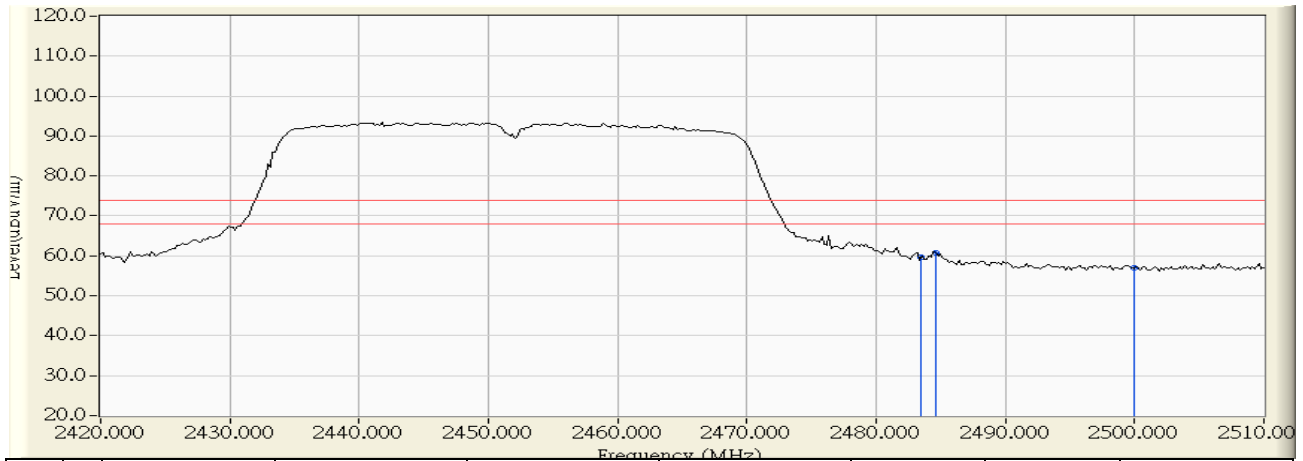

	Frequency (MHz)	Correct Factor (dB)	Reading Level (dBuV)	Measure Level (dBuV/m)	Margin (dB)	Limit (dBuV/m)	Detector Type
1	2483.500	31.512	28.182	59.694	-14.306	74.000	PEAK
2	* 2484.620	31.524	29.315	60.838	-13.162	74.000	PEAK
3	2500.000	31.638	25.398	57.037	-16.963	74.000	PEAK

Note:

1. All readings above 1GHz are performed with peak and/or average measurements as necessary.
2. Peak measurements: RBW = 1MHz, VBW = 3 MHz, Sweep: Auto.
3. Average measurements: RBW = 1MHz, VBW = 10 Hz, Sweep: Auto.
4. “ * ”, means this data is the worst emission level.
5. Measurement Level = Reading Level + Correct Factor.
6. The average measurement was not performed when the peak measured data under the limit of average detection.

Site : CB1	Time : 2011/10/27 - 13:28
Limit : FCC_SpartC_15.209_03M_AV	Margin : 6
Probe : EFS_1-18G-1_0901 - HORIZONTAL	Power : AC120V/60Hz
EUT : Wireless N Day/Night Internet Camera	Note : Mode 1: Transmit_2452MHz_802.11_n(40MHz)

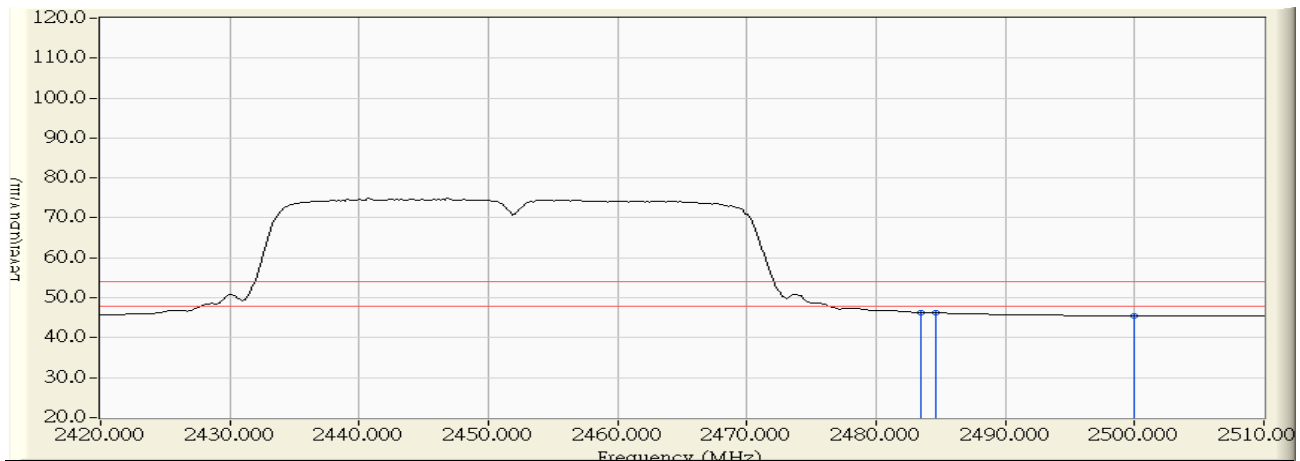

		Frequency (MHz)	Correct Factor (dB)	Reading Level (dBuV)	Measure Level (dBuV/m)	Margin (dB)	Limit (dBuV/m)	Detector Type
1	*	2483.500	31.512	14.843	46.355	-7.645	54.000	AVERAGE
2		2484.620	31.524	14.719	46.242	-7.758	54.000	AVERAGE
3		2500.000	31.638	13.862	45.501	-8.499	54.000	AVERAGE

Note:

1. All readings above 1GHz are performed with peak and/or average measurements as necessary.
2. Peak measurements: RBW = 1MHz, VBW = 3 MHz, Sweep: Auto.
3. Average measurements: RBW = 1MHz, VBW = 10 Hz, Sweep: Auto.
4. “ * ”, means this data is the worst emission level.
5. Measurement Level = Reading Level + Correct Factor.
6. The average measurement was not performed when the peak measured data under the limit of average detection.

Site : CB1	Time : 2011/10/27 - 13:33
Limit : FCC_SpartC_15.209_03M_PK	Margin : 6
Probe : EFS_1-18G-1_0901 - VERTICAL	Power : AC120V/60Hz
EUT : Wireless N Day/Night Internet Camera	Note : Mode 1: Transmit_2452MHz_802.11_n(40MHz)

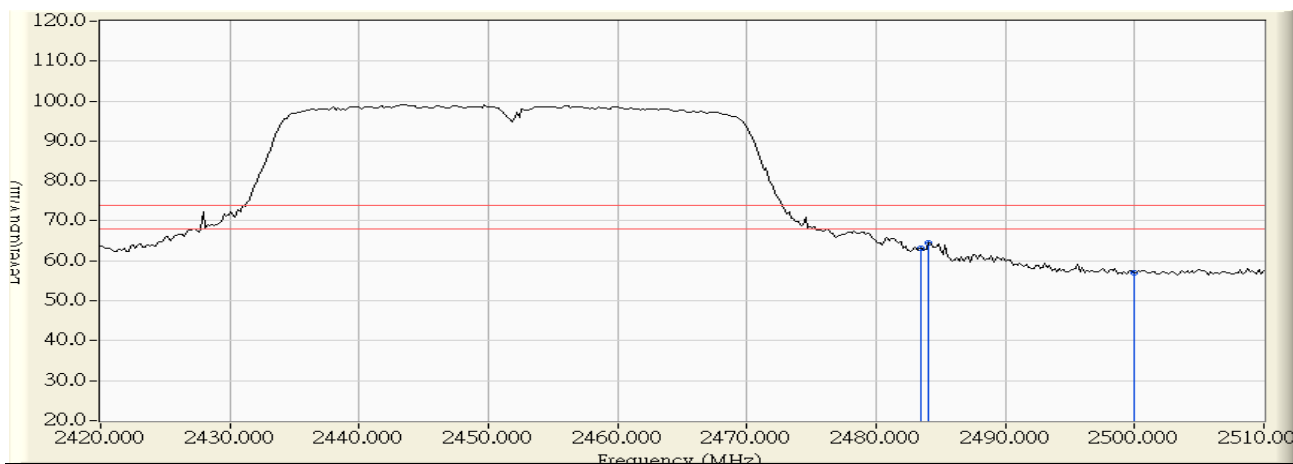

	Frequency (MHz)	Correct Factor (dB)	Reading Level (dBuV)	Measure Level (dBuV/m)	Margin (dB)	Limit (dBuV/m)	Detector Type
1	2483.500	31.512	31.692	63.204	-10.796	74.000	PEAK
2	* 2484.080	31.518	33.073	64.591	-9.409	74.000	PEAK
3	2500.000	31.638	25.286	56.925	-17.075	74.000	PEAK

Note:

1. All readings above 1GHz are performed with peak and/or average measurements as necessary.
2. Peak measurements: RBW = 1MHz, VBW = 3 MHz, Sweep: Auto.
3. Average measurements: RBW = 1MHz, VBW = 10 Hz, Sweep: Auto.
4. “ * ”, means this data is the worst emission level.
5. Measurement Level = Reading Level + Correct Factor.
6. The average measurement was not performed when the peak measured data under the limit of average detection.

Site : CB1	Time : 2011/10/27 - 13:34
Limit : FCC_SpartC_15.209_03M_AV	Margin : 6
Probe : EFS_1-18G-1_0901 - VERTICAL	Power : AC120V/60Hz
EUT : Wireless N Day/Night Internet Camera	Note : Mode 1: Transmit_2452MHz_802.11_n(40MHz)

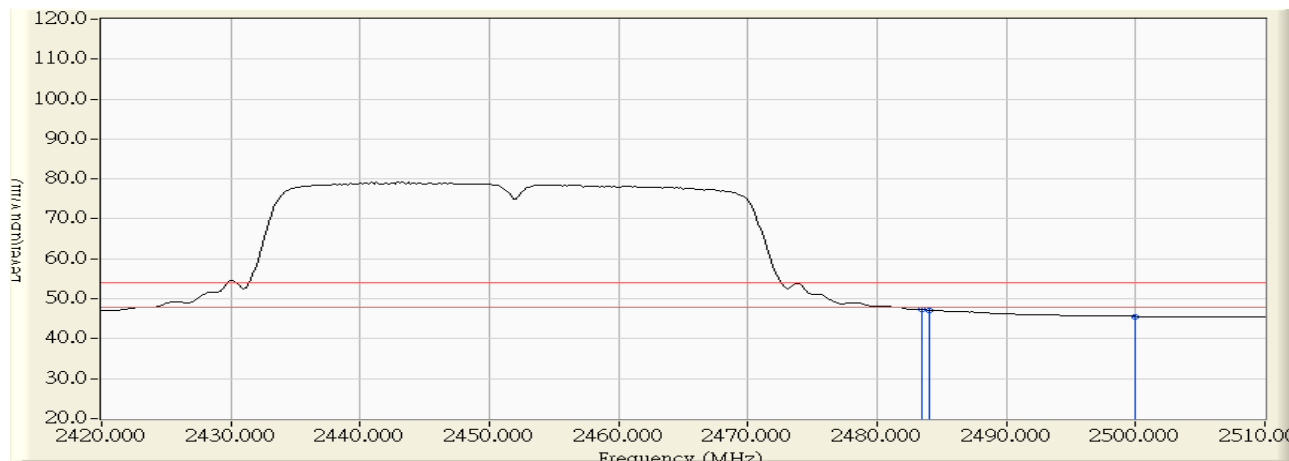

		Frequency (MHz)	Correct Factor (dB)	Reading Level (dBuV)	Measure Level (dBuV/m)	Margin (dB)	Limit (dBuV/m)	Detector Type
1	*	2483.500	31.512	15.708	47.220	-6.780	54.000	AVERAGE
2		2484.080	31.518	15.651	47.169	-6.831	54.000	AVERAGE
3		2500.000	31.638	13.953	45.592	-8.408	54.000	AVERAGE

Note:

1. All readings above 1GHz are performed with peak and/or average measurements as necessary.
2. Peak measurements: RBW = 1MHz, VBW = 3 MHz, Sweep: Auto.
3. Average measurements: RBW = 1MHz, VBW = 10 Hz, Sweep: Auto.
4. “ * ”, means this data is the worst emission level.
5. Measurement Level = Reading Level + Correct Factor.
6. The average measurement was not performed when the peak measured data under the limit of average detection.

7. Occupied Bandwidth

7.1. Test Equipment

The following test equipments are used during the test:

Occupied Bandwidth / SR7

Instrument	Manufacturer	Model No.	Serial No	Next Cal. Date
Spectrum Analyzer	R&S	FSP	100561	2012/01/16

Note: 1. All equipments that need to calibrate are with calibration period of 1 year.

7.2. Test Setup

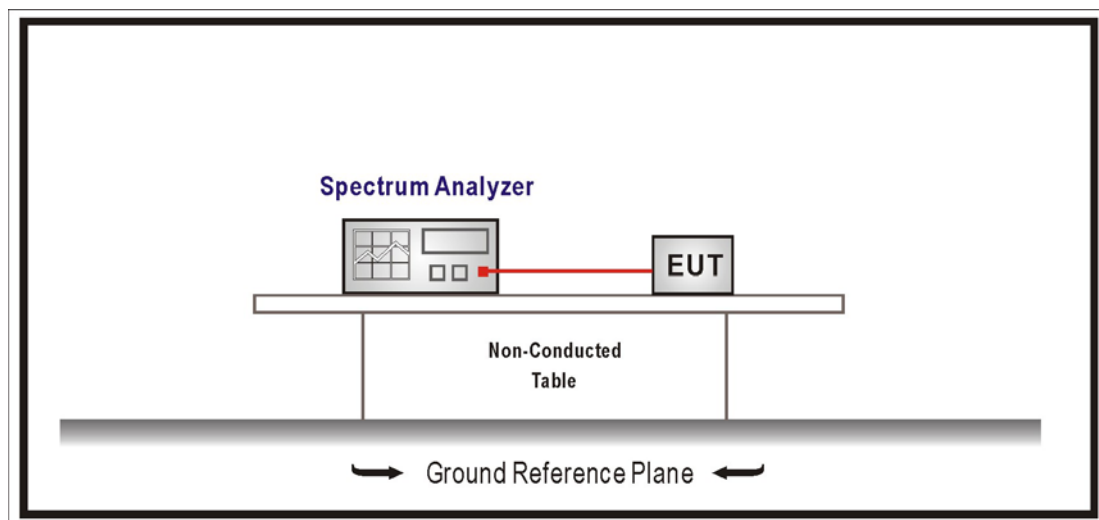

7.3. Test Procedures

The EUT was setup according to ANSI C63.4: 2009; tested according to DTS test procedure of Oct 2002 KDB558074 for compliance to FCC 47CFR 15.247 requirements.

Set RBW = 100 kHz, Span greater than RBW.

7.4. Limits

The 6 dB bandwidth must be greater than 500 kHz.

7.5. Test Specification

According to FCC Part 15 Subpart C Paragraph 15.247: 2010

7.6. Uncertainty

The measurement uncertainty is defined as $\pm 150\text{Hz}$

7.7. Test Result

Product	Wireless N Day/Night Internet Camera		
Test Item	Occupied Bandwidth		
Test Mode	Mode 1: Transmit		
Date of Test	2011/10/28	Test Site	SR7

802.11 b				
Channel No.	Frequency (MHz)	Measurement Level (MHz)	Required Limit (MHz)	Result
1	2412	10.32	0.5	Pass
6	2437	11.28	0.5	Pass
11	2462	10.32	0.5	Pass

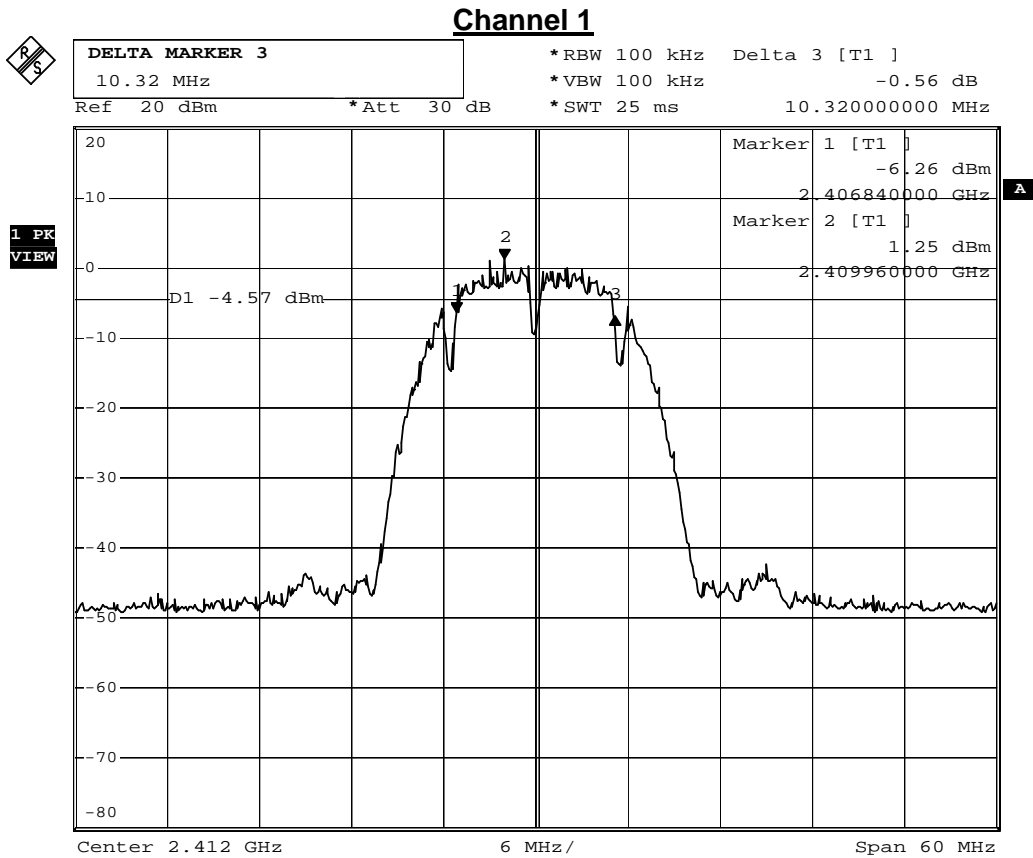

Date: 28.OCT.2011 12:12:11

Channel 6

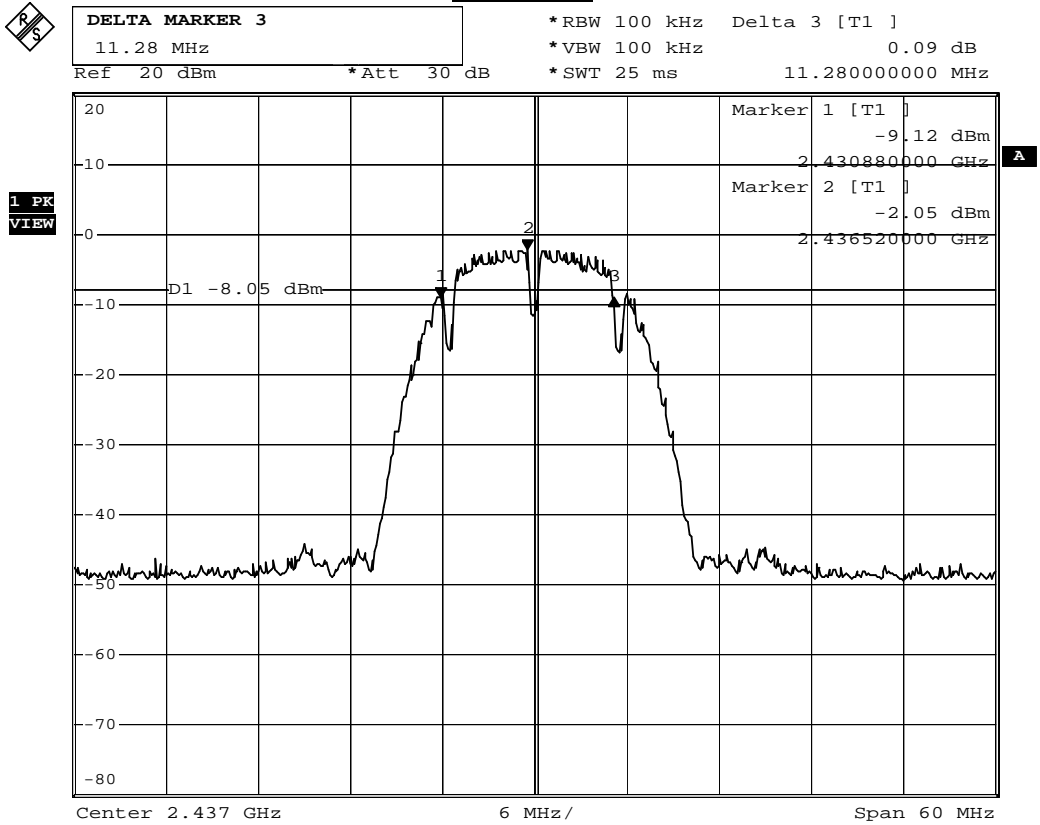

Date: 28.OCT.2011 12:18:33

Channel 11



DELTA MARKER 3
10.32 MHz

Ref 20 dBm *Att 30 dB

*RBW 100 kHz Delta 3 [T1]

*VBW 100 kHz -0.72 dB

*SWT 25 ms 10.320000000 MHz

1 PK
VIEW

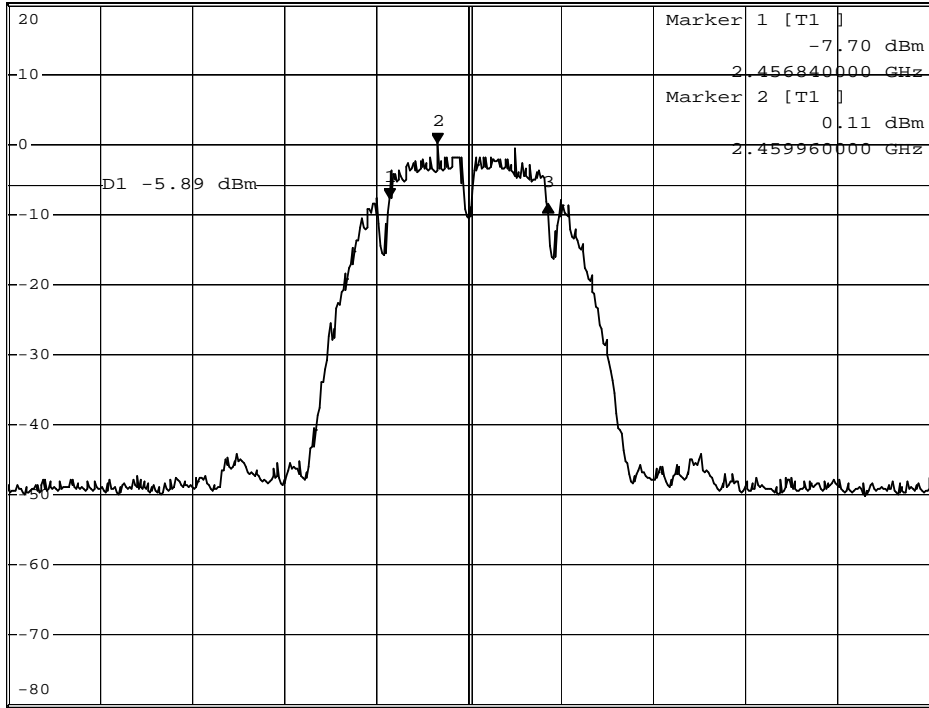

Center 2.462 GHz

6 MHz/

Span 60 MHz

Date: 28.OCT.2011 12:21:47

Product	Wireless N Day/Night Internet Camera		
Test Item	Occupied Bandwidth		
Test Mode	Mode 1: Transmit		
Date of Test	2011/10/28	Test Site	SR7

IEEE 802.11g				
Channel No.	Frequency (MHz)	Measurement Level (MHz)	Required Limit (MHz)	Result
1	2412	16.56	0.5	Pass
6	2437	16.56	0.5	Pass
11	2462	16.56	0.5	Pass

Channel 1

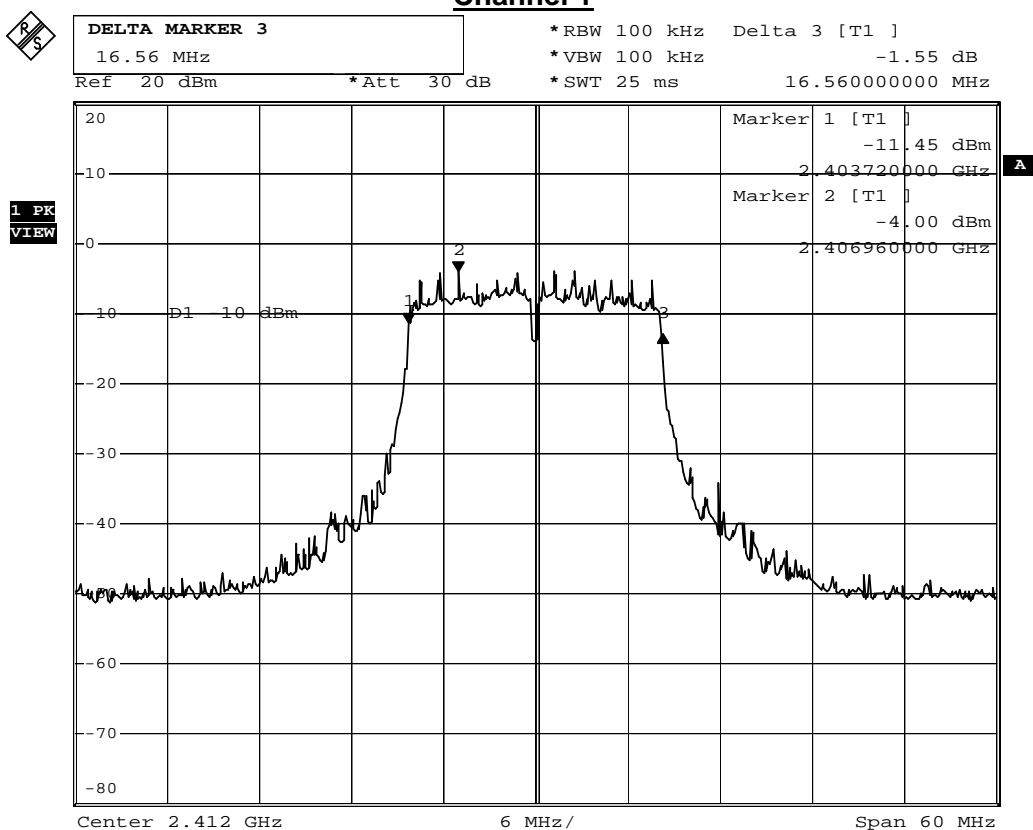

Date: 28.OCT.2011 12:23:17

Channel 6



DELTA MARKER 3
16.56708 MHz

*RBW 100 kHz Delta 3 [T1]
*VBW 100 kHz -1.22 dB
*SWT 25 ms 16.567080000 MHz

Ref 20 dBm *Att 30 dB

1 PK
VIEW

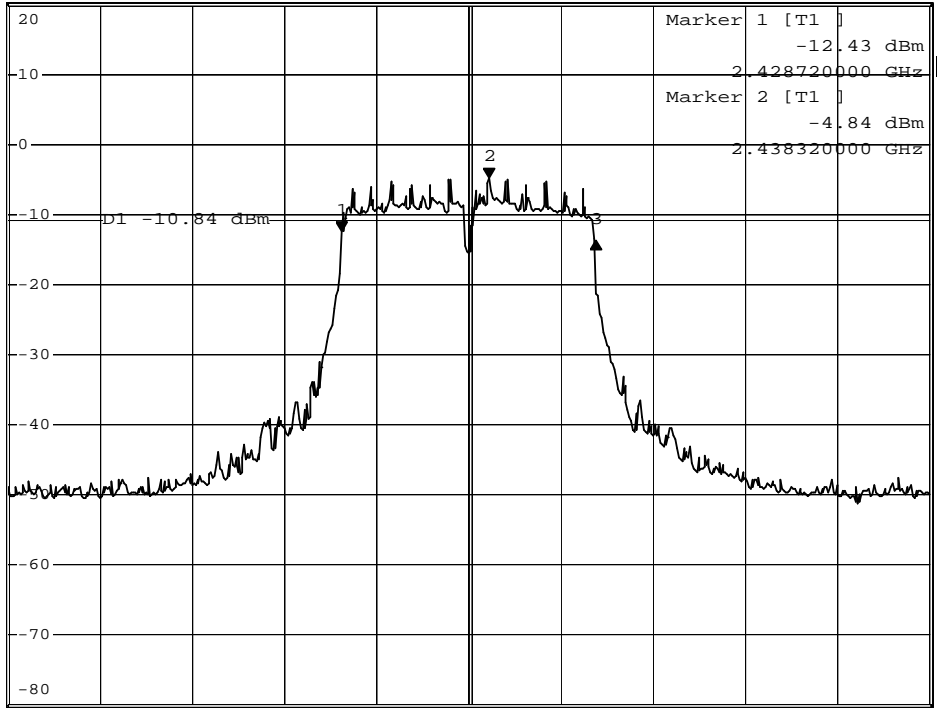

Center 2.437 GHz 6 MHz/ Span 60 MHz

Date: 28.OCT.2011 12:25:06

Channel 11



DELTA MARKER 3
16.56 MHz

*RBW 100 kHz Delta 3 [T1]
*VBW 100 kHz -0.62 dB
*SWT 25 ms 16.560000000 MHz

Ref 20 dBm *Att 30 dB

1 PK
VIEW

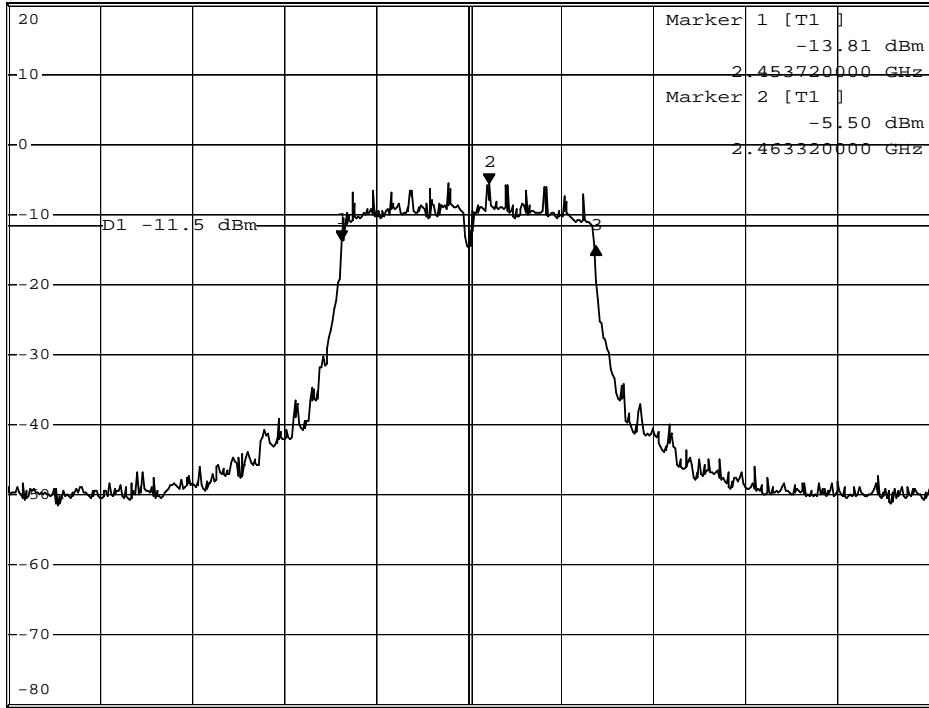

Center 2.462 GHz 6 MHz/ Span 60 MHz

Date: 28.OCT.2011 12:26:30

Product	Wireless N Day/Night Internet Camera		
Test Item	Occupied Bandwidth		
Test Mode	Mode 1: Transmit		
Date of Test	2011/10/28	Test Site	SR7

IEEE 802.11n (20MHz)				
Channel No.	Frequency (MHz)	Measurement Level (MHz)	Required Limit (MHz)	Result
1	2412	17.28	0.5	Pass
6	2437	17.40	0.5	Pass
11	2462	17.16	0.5	Pass

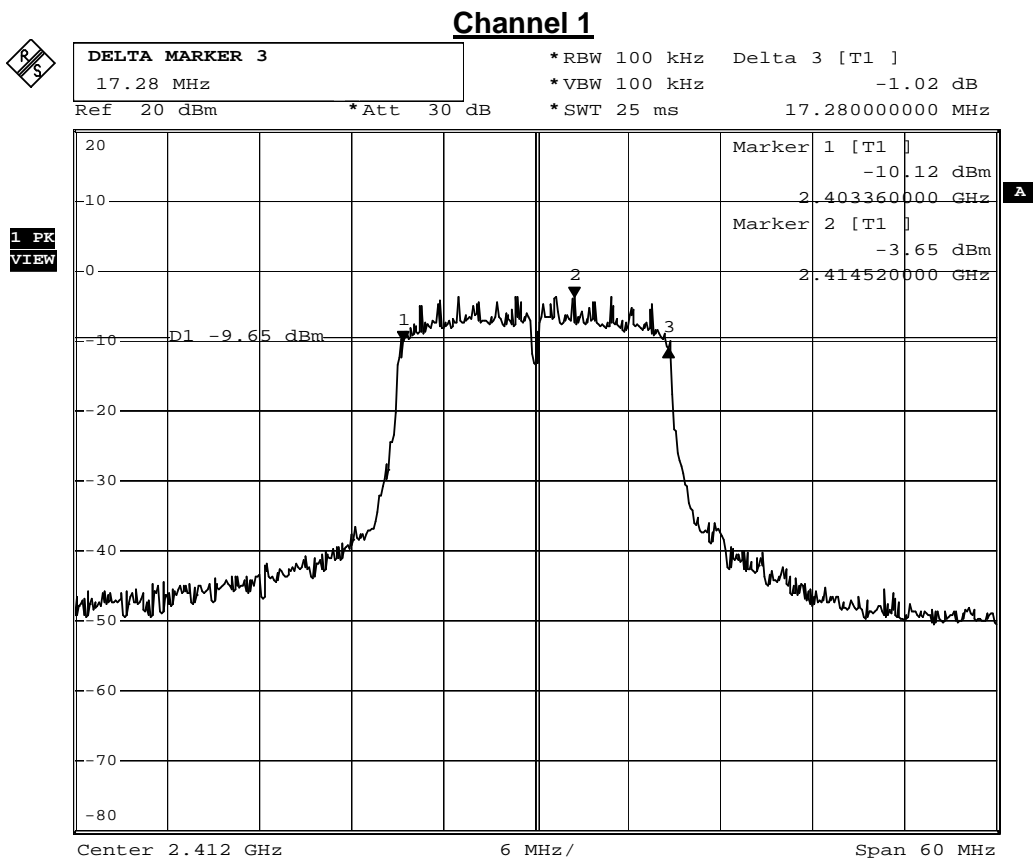

Date: 28.OCT.2011 13:27:28

Channel 6

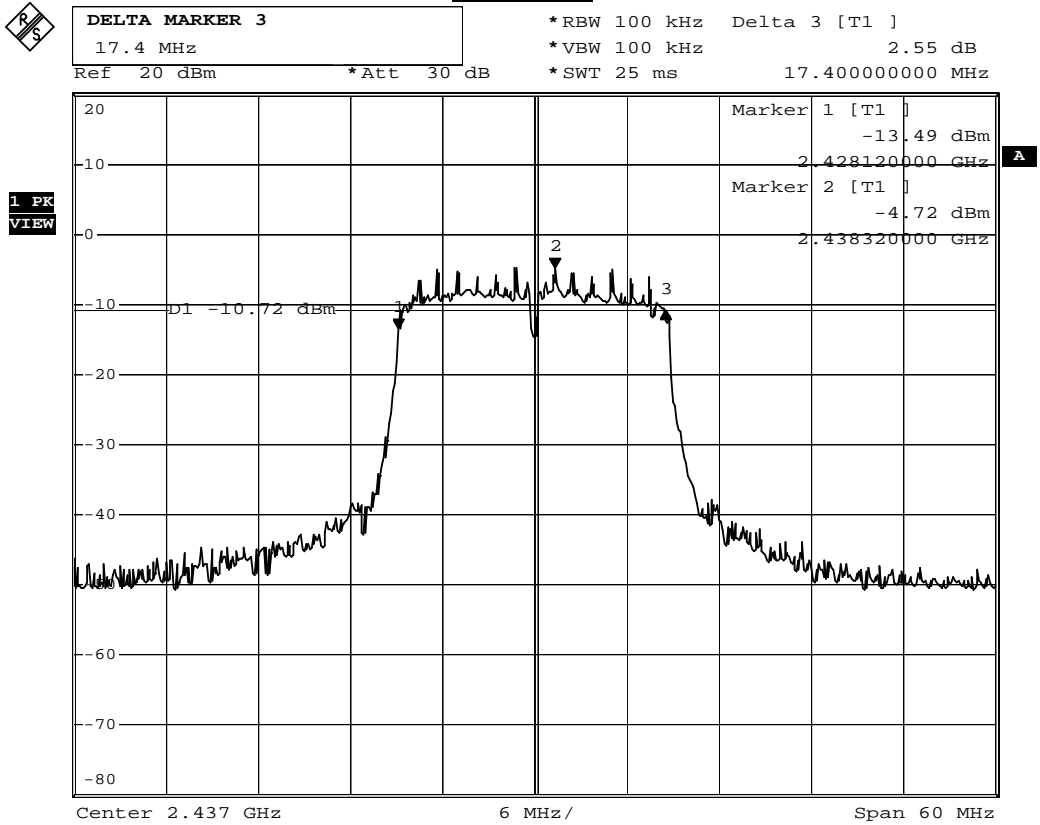

Date: 28.OCT.2011 13:33:13

Channel 11



DELTA MARKER 3
 17.16 MHz
 Ref 20 dBm *Att 30 dB

*RBW 100 kHz Delta 3 [T1]
 *VBW 100 kHz 0.26 dB
 *SWT 25 ms 17.160000000 MHz

1 PK
 VIEW

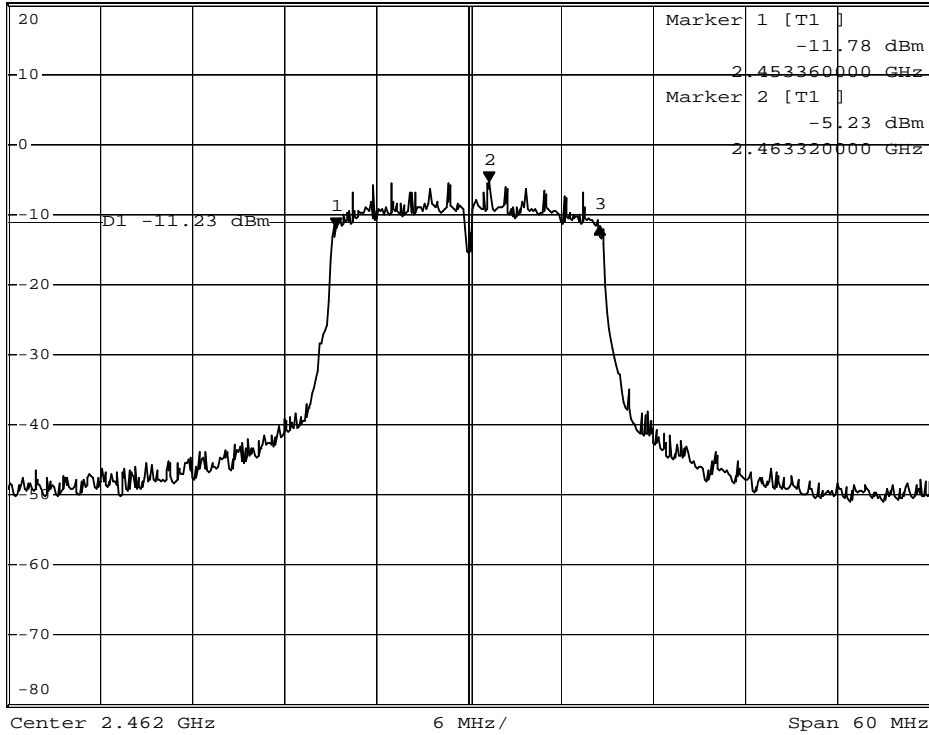

Date: 28.OCT.2011 13:35:04

Product	Wireless N Day/Night Internet Camera		
Test Item	Occupied Bandwidth		
Test Mode	Transmit		
Date of Test	2011/10/28	Test Site	SR7

IEEE 802.11n (40MHz)				
Channel No.	Frequency (MHz)	Measurement Level (MHz)	Required Limit (MHz)	Result
3	2422	35.52	0.5	Pass
6	2437	35.52	0.5	Pass
9	2452	35.52	0.5	Pass

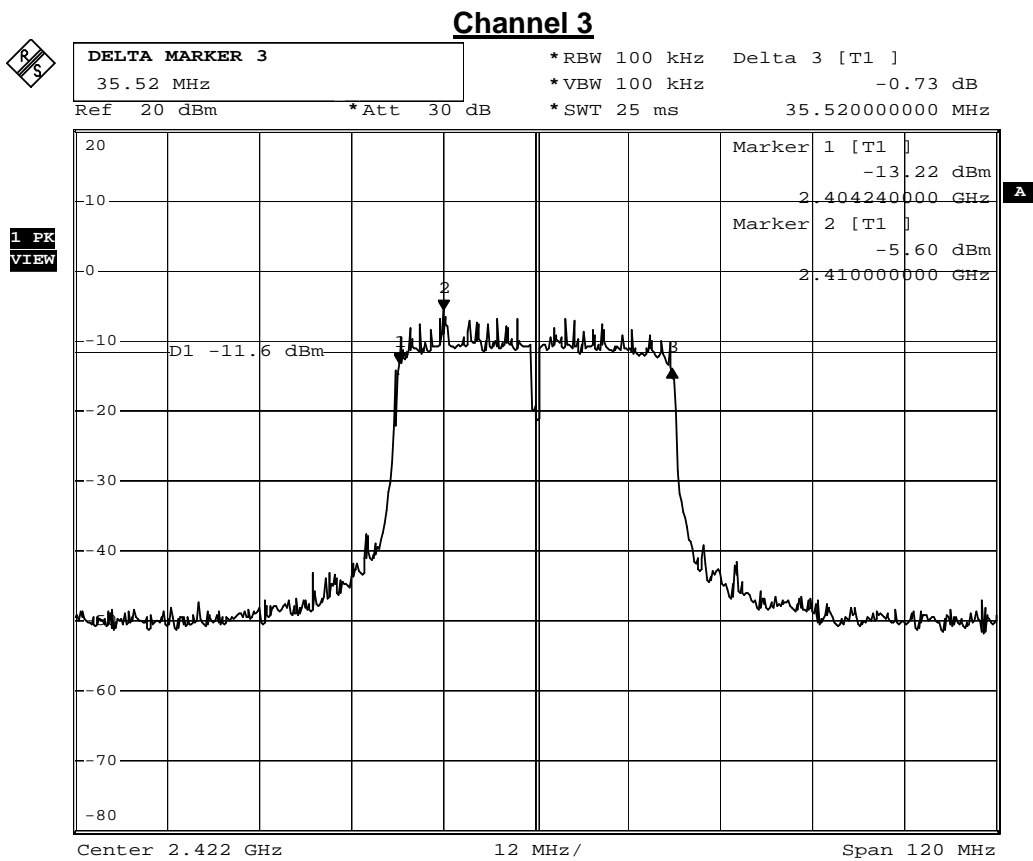

Date: 28.OCT.2011 13:39:58

Channel 6



DELTA MARKER 3
35.52 MHz

*RBW 100 kHz Delta 3 [T1]
*VBW 100 kHz -1.05 dB
*SWT 25 ms 35.52000000 MHz

Ref 20 dBm *Att 30 dB

1 PK
VIEW

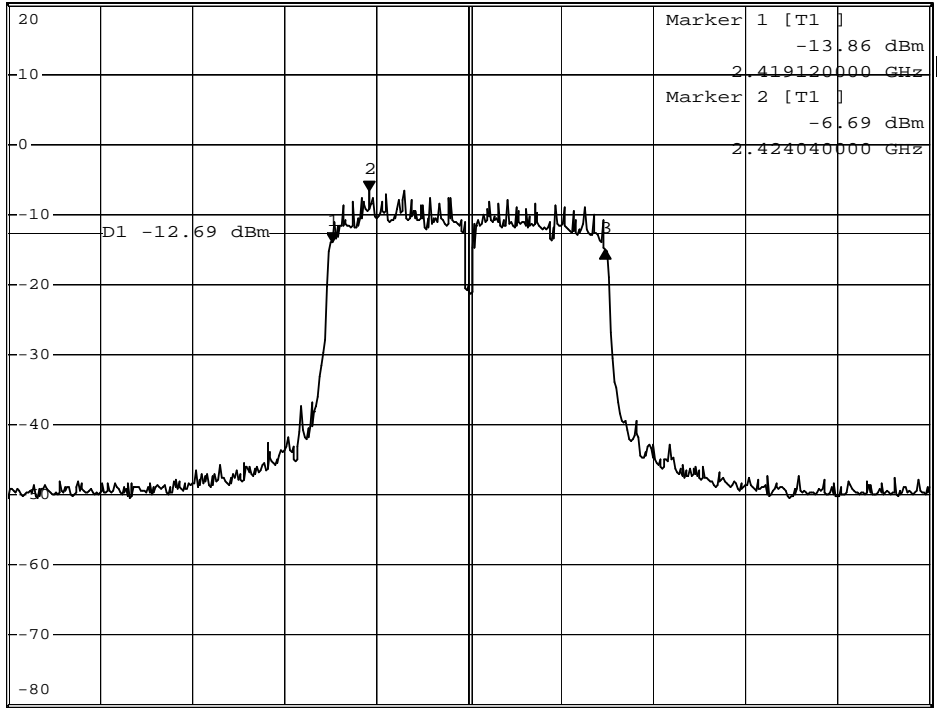

Center 2.437 GHz 12 MHz/ Span 120 MHz

Date: 28.OCT.2011 13:41:34

Channel 9



DELTA MARKER 3
35.52 MHz

*RBW 100 kHz Delta 3 [T1]
*VBW 100 kHz -0.78 dB
*SWT 25 ms 35.52000000 MHz

Ref 20 dBm *Att 30 dB

1 PK
VIEW

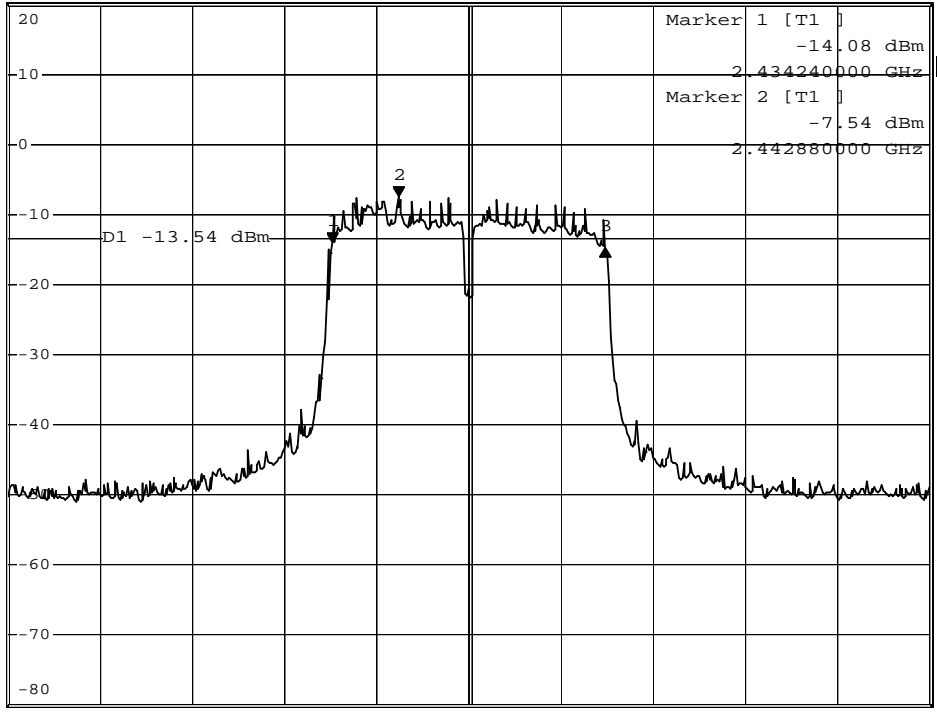

Date: 28.OCT.2011 13:44:56

8. Power Density

8.1. Test Equipment

The following test equipment are used during the test:

Power Density / SR7

Instrument	Manufacturer	Model No.	Serial No	Next Cal. Date
Spectrum Analyzer	R&S	FSP	100561	2012/01/16

Note: 1. All equipments that need to calibrate are with calibration period of 1 year.

8.2. Test Setup

IEEE 802.11 b / g / n (20M / 40M) MODE

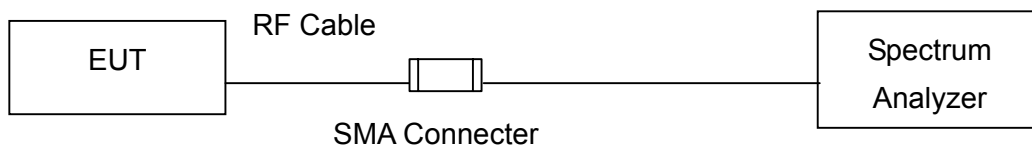

8.3. Limits

The peak power spectral density conducted from the intentional radiated to the antenna shall not be greater than +8dBm in any 3kHz band during any time interval of continuous transmission.

8.4. Test Procedures

The EUT was setup according to ANSI C63.4: 2009; tested according to DTS test procedure of Oct 2002 KDB558074 for compliance to FCC 47CFR 15.247 requirements.

Set RBW= 3 kHz, Set VBW \geq 9 kHz, Sweep time=Auto, Set detector=Peak detector

8.5. Test Specification

According to FCC Part 15 Subpart C Paragraph 15.247: 2010

8.6. Uncertainty

The measurement uncertainty is defined as ± 1.27 dB.

8.7. Test Result

Product	Wireless N Day/Night Internet Camera		
Test Item	Power Density		
Test Mode	Mode 1: Transmit		
Date of Test	2011/10/17	Test Site	SR7

IEEE 802.11b				
Channel No.	Frequency (MHz)	Measure Level (dBm)	Limit (dBm)	Result
1	2412	-16.05	≤8	Pass
6	2437	-16.62	≤8	Pass
11	2462	-15.70	≤8	Pass

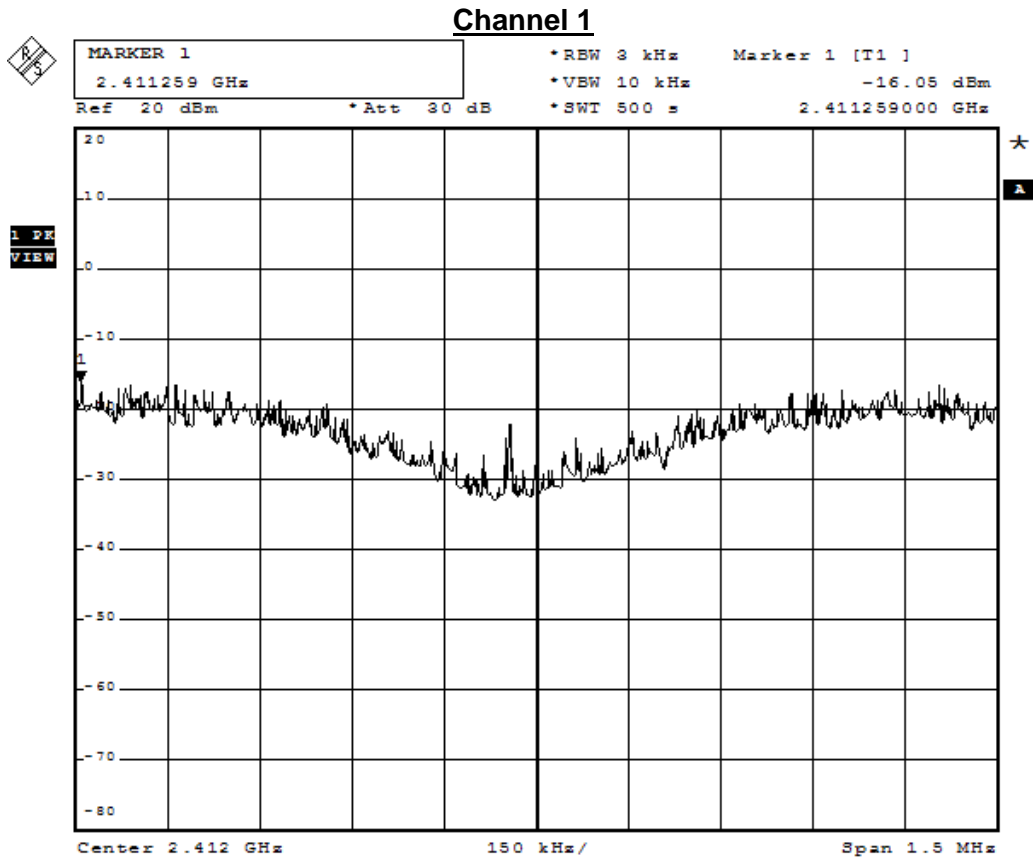

Channel 6

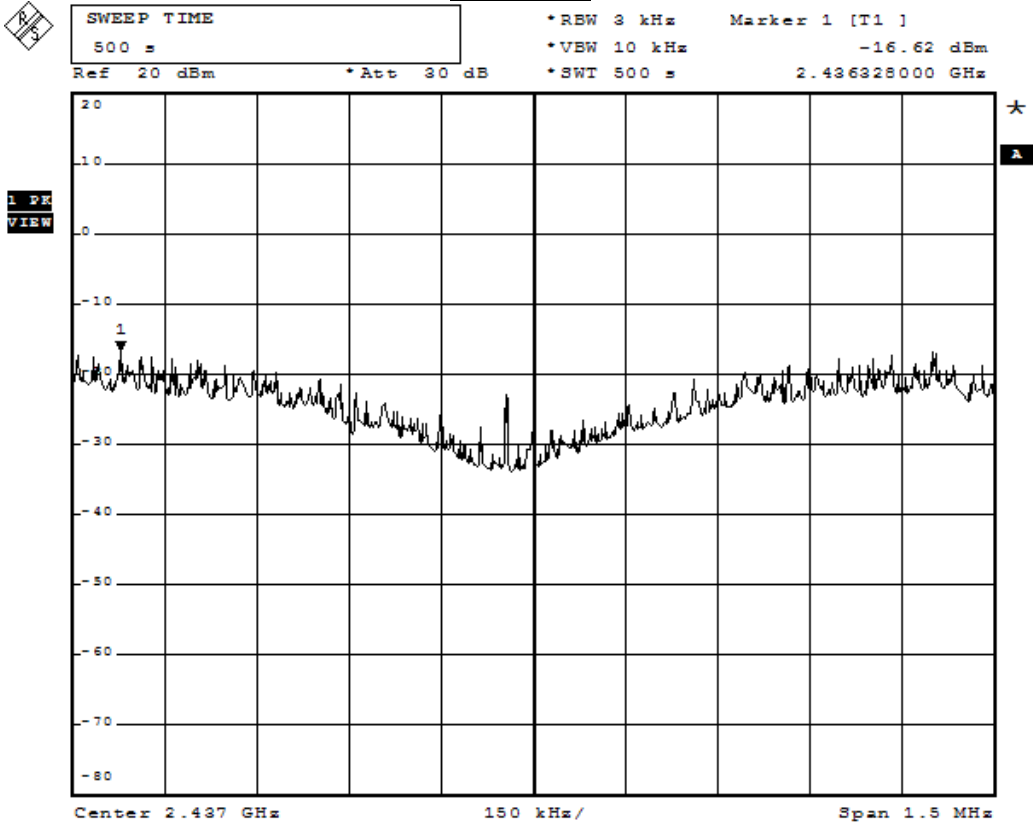

Channel 11

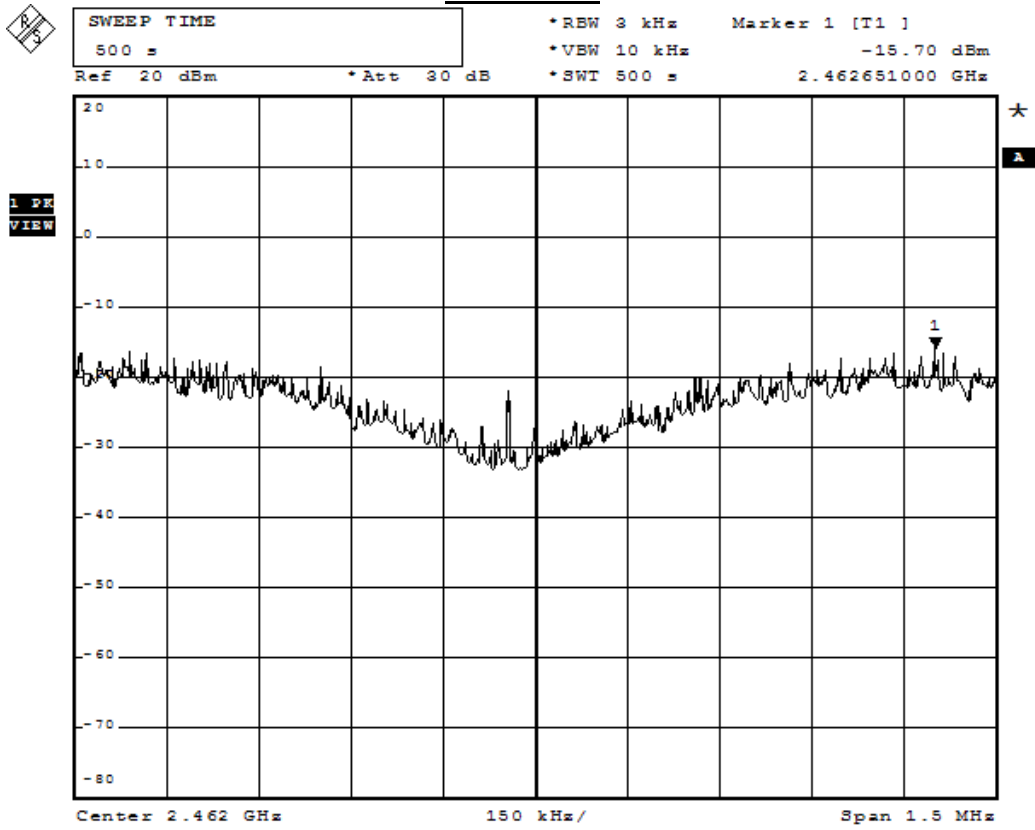

Product	Wireless N Day/Night Internet Camera		
Test Item	Power Density		
Test Mode	Mode 1: Transmit		
Date of Test	2011/10/17	Test Site	SR7

IEEE 802.11g				
Channel No.	Frequency (MHz)	Measure Level (dBm)	Limit (dBm)	Result
1	2412	-19.05	≤8	Pass
6	2437	-20.67	≤8	Pass
11	2462	-21.38	≤8	Pass

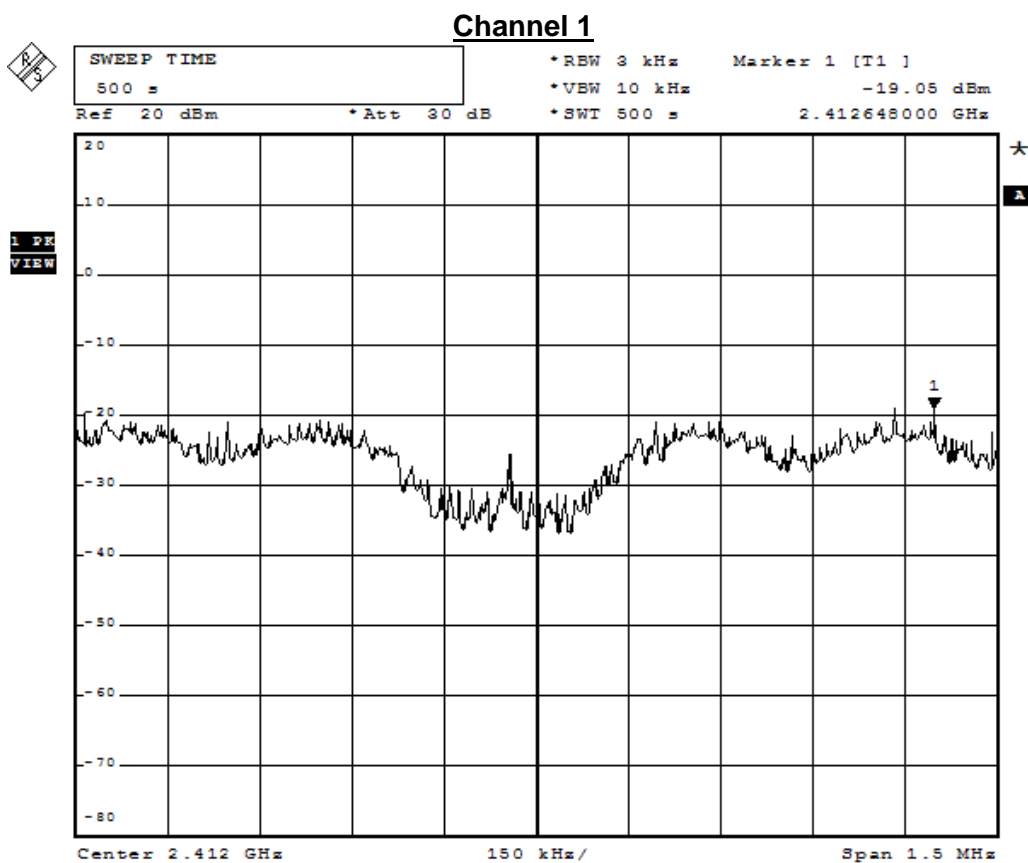

Channel 6

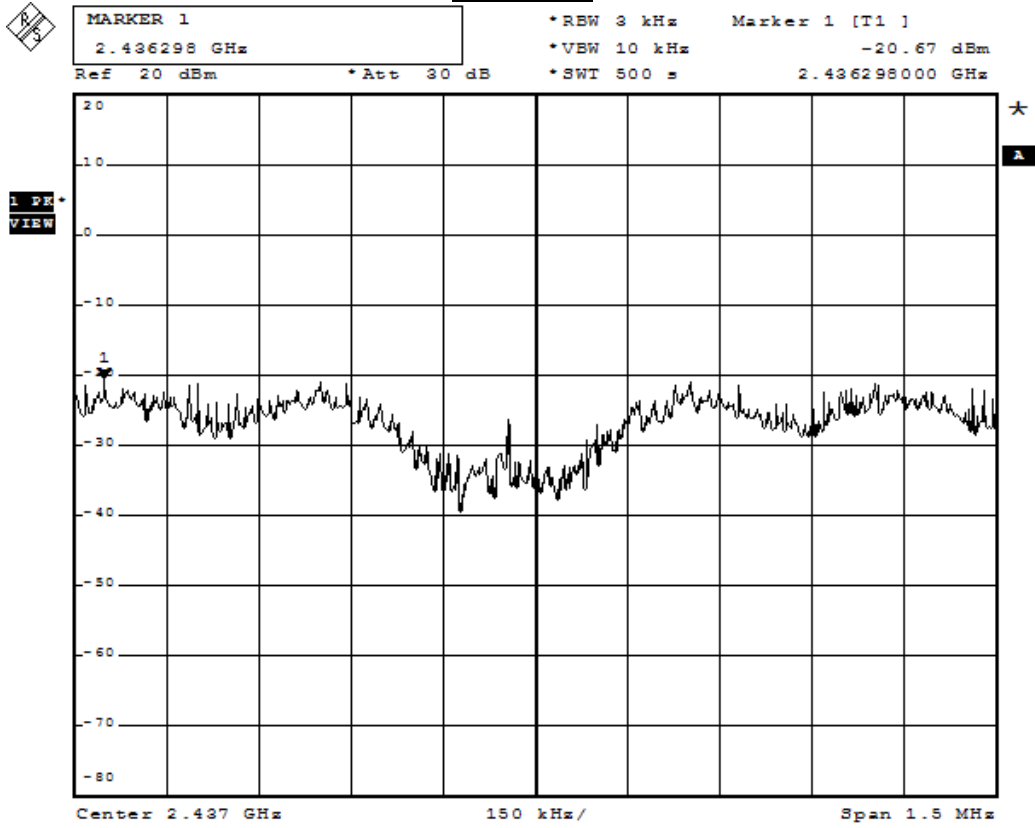

Channel 11

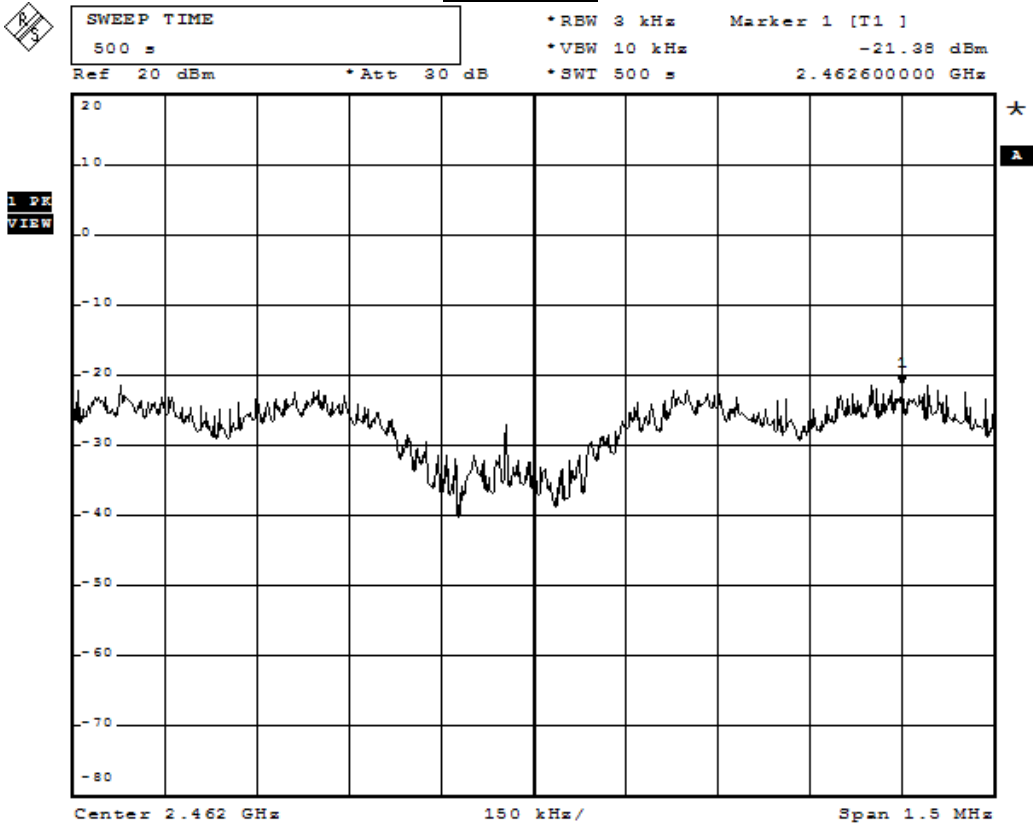

Product	Wireless N Day/Night Internet Camera		
Test Item	Power Density		
Test Mode	Mode 1: Transmit		
Date of Test	2011/10/17	Test Site	SR7

IEEE802.11n MCS0 20MHz_Tx				
Channel No.	Frequency (MHz)	Measure Level (dBm)	Limit (dBm)	Result
1	2412	-23.97	≤8	Pass
6	2437	-20.35	≤8	Pass
11	2462	-21.37	≤8	Pass

IEEE802.11n MCS0 20MHz_Tx
Channel 1

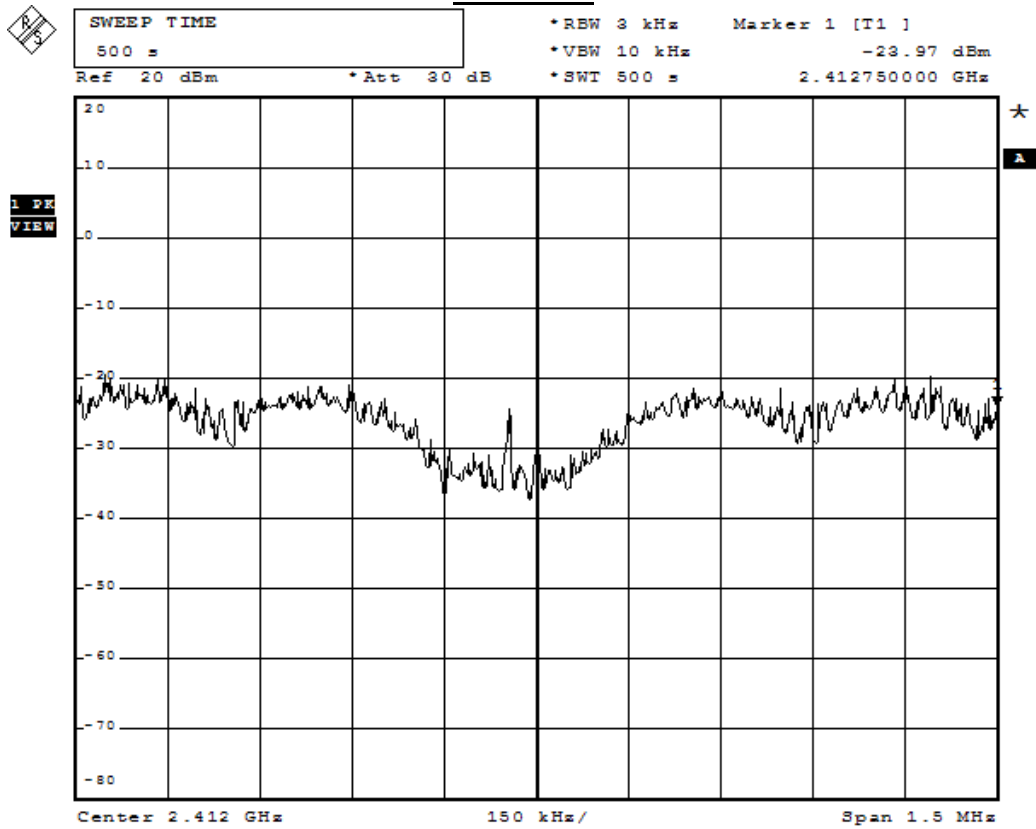

IEEE802.11n MCS0 20MHz_Tx
Channel 6

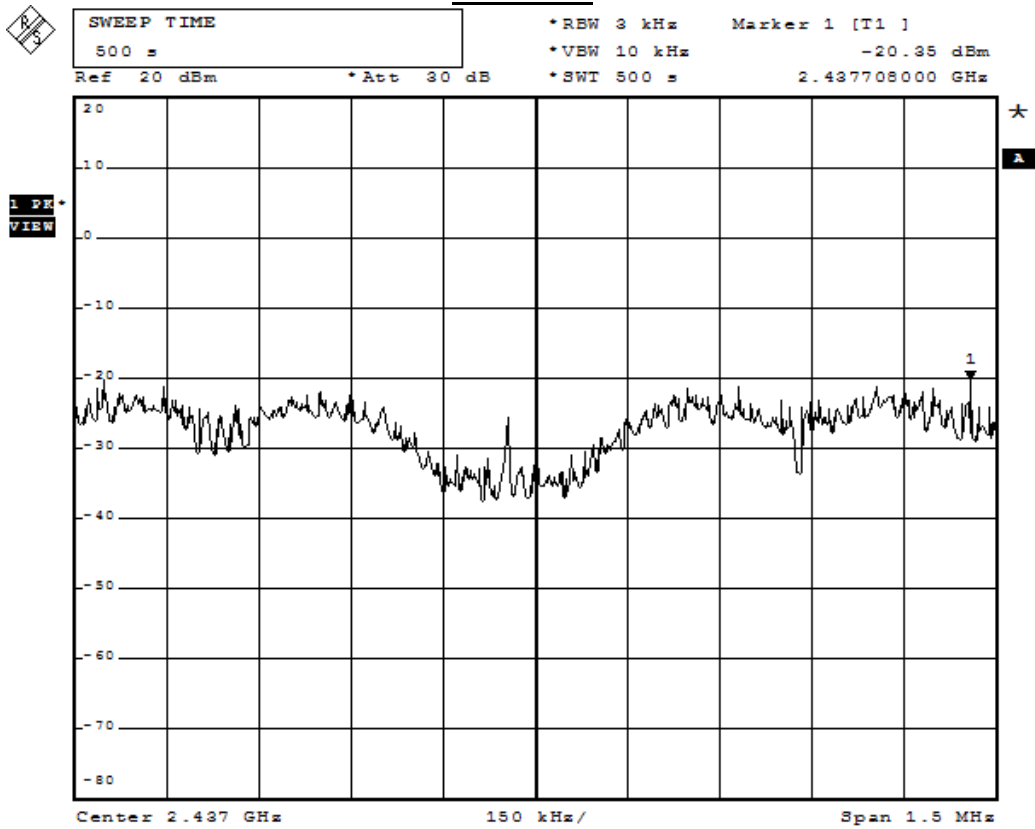

IEEE802.11n MCS0 20MHz_Tx
Channel 11

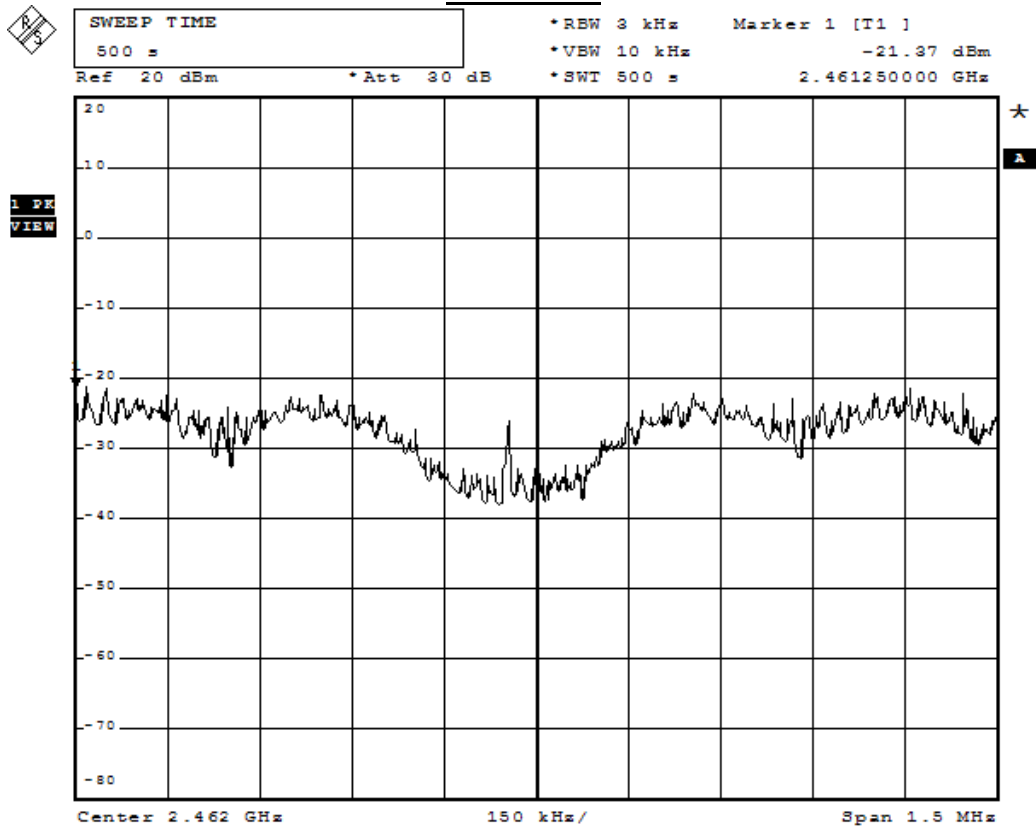

Product	Wireless N Day/Night Internet Camera		
Test Item	Power Density		
Test Mode	Mode 1: Transmit		
Date of Test	2011/10/17	Test Site	SR7

IEEE 802.11n MCS0 40MHz_Tx				
Channel No.	Frequency (MHz)	Measure Level (dBm)	Limit (dBm)	Result
3	2422	-24.46	≤ 8	Pass
6	2437	-25.13	≤ 8	Pass
9	2452	-25.20	≤ 8	Pass

IEEE 802.11n MCS0 40MHz_Tx Channel 3

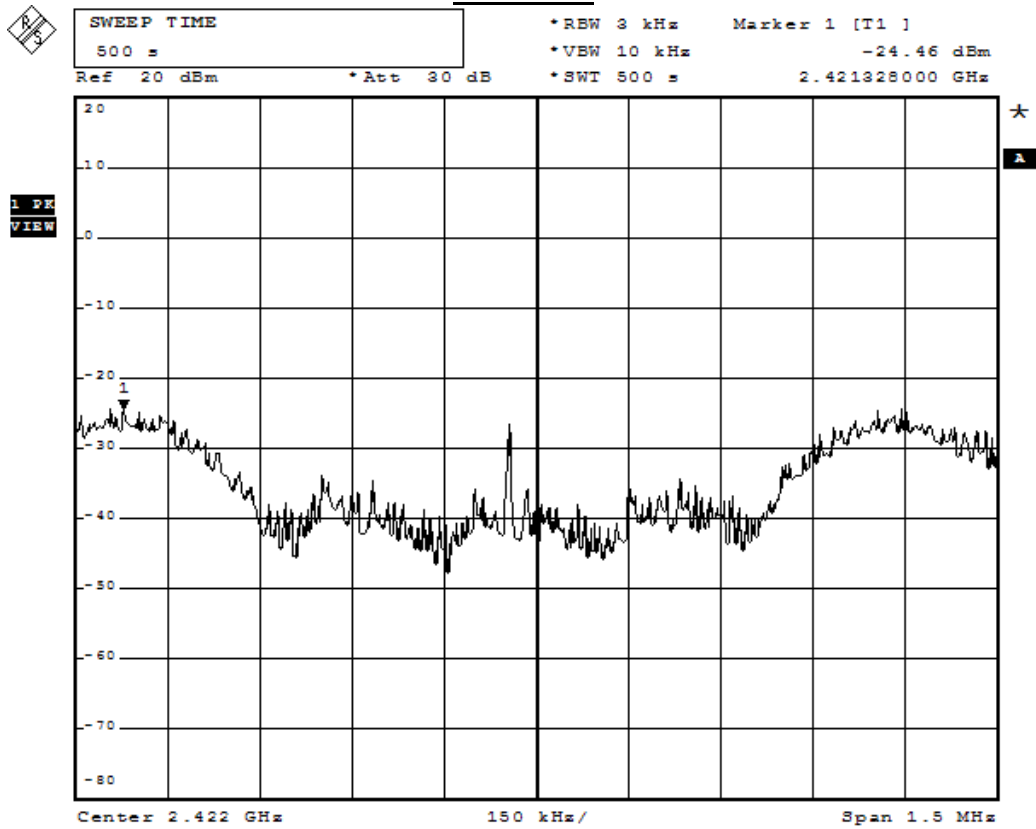

IEEE 802.11n MCS0 40MHz_Tx Channel 6

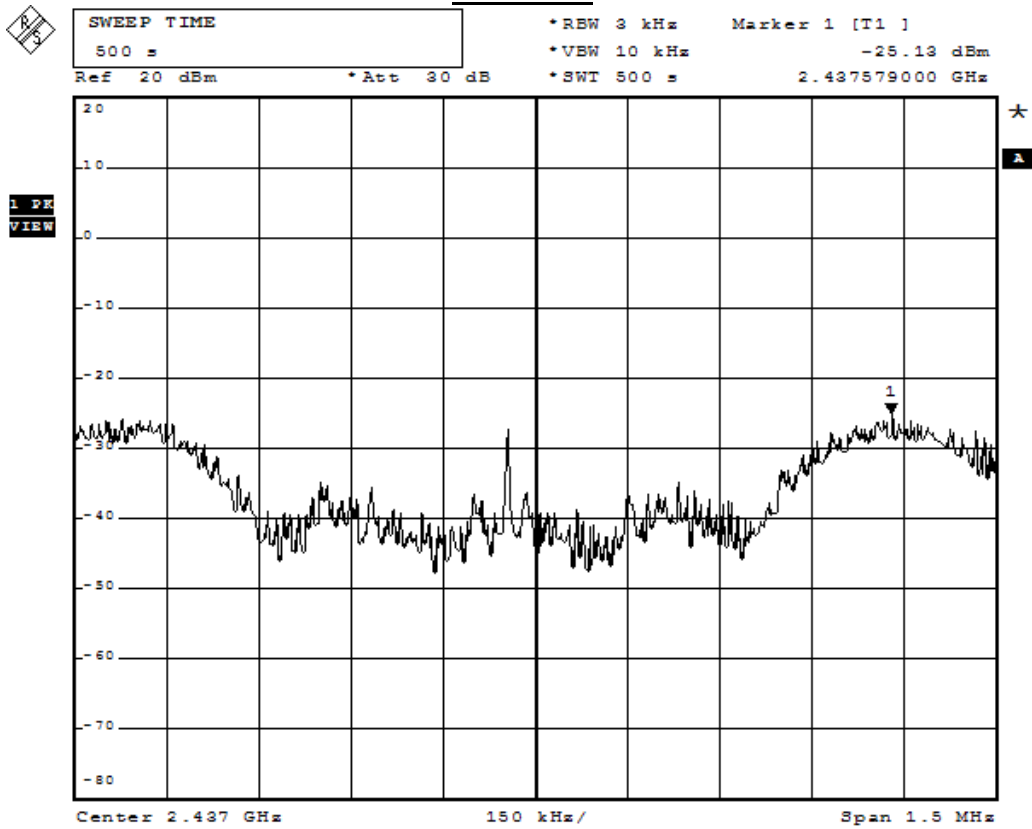

IEEE 802.11n MCS0 40MHz_Tx Channel 9

