



# FCC TEST REPORT (15.247)

**REPORT NO.:** RF130328E02

**MODEL NO.:** TEW-751DR

**FCC ID:** XU8TEW751DR2

**RECEIVED:** Mar. 28, 2013

**TESTED:** Apr. 08 to 11, 2013

**ISSUED:** June 06, 2013

**APPLICANT:** TRENDnet, Inc

**ADDRESS:** 20675 Manhattan Place, Torrance, CA 90501  
U.S.A.

**ISSUED BY:** Bureau Veritas Consumer Products Services  
(H.K.) Ltd., Taoyuan Branch Hsin Chu Laboratory

**LAB ADDRESS :** No. 81-1, Lu Liao Keng, 9th Ling, Wu Lung Tsuen,  
Chiung Lin Hsiang, Hsin Chu Hsien 307, Taiwan,  
R.O.C.

**TEST LOCATION (1):** No. 81-1, Lu Liao Keng, 9th Ling, Wu Lung Tsuen,  
Chiung Lin Hsiang, Hsin Chu Hsien 307, Taiwan,  
R.O.C.

**TEST LOCATION (2):** No. 49, Ln. 206, Wende Rd., Shangshan Tsuen,  
Chiung Lin Hsiang, Hsin Chu Hsien 307, Taiwan,  
R.O.C.

This report should not be used by the client to claim product certification, approval, or endorsement by TAF or any government agencies.



This report is for your exclusive use. Any copying or replication of this report to or for any other person or entity, or use of our name or trademark, is permitted only with our prior written permission. This report sets forth our findings solely with respect to the test samples identified herein. The results set forth in this report are not indicative or representative of the quality or characteristics of the lot from which a test sample was taken or any similar or identical product unless specifically and expressly noted. Our report includes all of the tests requested by you and the results thereof based upon the information that you provided to us. You have 60 days from date of issuance of this report to notify us of any material error or omission caused by our negligence, provided, however, that such notice shall be in writing and shall specifically address the issue you wish to raise. A failure to raise such issue within the prescribed time shall constitute your unqualified acceptance of the completeness of this report, the tests conducted and the correctness of the report contents. Unless specific mention, the uncertainty of measurement has been explicitly taken into account to declare the compliance or non-compliance to the specification



A D T

## Table of Contents

|                                                                      |    |
|----------------------------------------------------------------------|----|
| RELEASE CONTROL RECORD .....                                         | 5  |
| 1. CERTIFICATION .....                                               | 6  |
| 2. SUMMARY OF TEST RESULTS .....                                     | 7  |
| 2.1 MEASUREMENT UNCERTAINTY .....                                    | 8  |
| 3. GENERAL INFORMATION .....                                         | 9  |
| 3.1 GENERAL DESCRIPTION OF EUT .....                                 | 9  |
| 3.2 DESCRIPTION OF TEST MODES .....                                  | 12 |
| 3.2.1 TEST MODE APPLICABILITY AND TESTED CHANNEL DETAIL .....        | 13 |
| 3.3 GENERAL DESCRIPTION OF APPLIED STANDARDS .....                   | 16 |
| 3.4 DESCRIPTION OF SUPPORT UNITS .....                               | 17 |
| 3.5 CONFIGURATION OF SYSTEM UNDER TEST .....                         | 18 |
| 4. TEST TYPES AND RESULTS (FOR 2.4GHz, 2.400 ~ 2.4835GHz Band) ..... | 19 |
| 4.1 CONDUCTED EMISSION MEASUREMENT .....                             | 19 |
| 4.1.1 LIMITS OF CONDUCTED EMISSION MEASUREMENT .....                 | 19 |
| 4.1.2 TEST INSTRUMENTS .....                                         | 19 |
| 4.1.3 TEST PROCEDURES .....                                          | 20 |
| 4.1.4 DEVIATION FROM TEST STANDARD .....                             | 20 |
| 4.1.5 TEST SETUP .....                                               | 20 |
| 4.1.6 EUT OPERATING CONDITIONS .....                                 | 21 |
| 4.1.7 TEST RESULTS .....                                             | 22 |
| 4.2 RADIATED EMISSION AND BANDEDGE MEASUREMENT .....                 | 26 |
| 4.2.1 LIMITS OF RADIATED EMISSION AND BANDEDGE MEASUREMENT .....     | 26 |
| 4.2.2 TEST INSTRUMENTS .....                                         | 27 |
| 4.2.3 TEST PROCEDURES .....                                          | 28 |
| 4.2.4 DEVIATION FROM TEST STANDARD .....                             | 28 |
| 4.2.5 TEST SETUP .....                                               | 29 |
| 4.2.6 EUT OPERATING CONDITIONS .....                                 | 29 |
| 4.2.7 TEST RESULTS .....                                             | 30 |
| 4.3 6dB BANDWIDTH MEASUREMENT .....                                  | 43 |
| 4.3.1 LIMITS OF 6dB BANDWIDTH MEASUREMENT .....                      | 43 |
| 4.3.2 TEST INSTRUMENTS .....                                         | 43 |
| 4.3.3 TEST PROCEDURE .....                                           | 43 |
| 4.3.4 DEVIATION FROM TEST STANDARD .....                             | 43 |
| 4.3.5 TEST SETUP .....                                               | 43 |
| 4.3.6 EUT OPERATING CONDITIONS .....                                 | 43 |
| 4.3.7 TEST RESULTS .....                                             | 44 |
| 4.4 CONDUCTED OUTPUT POWER MEASUREMENT .....                         | 45 |
| 4.4.1 LIMITS OF MAXIMUM PEAK OUTPUT POWER MEASUREMENT .....          | 45 |
| 4.4.2 INSTRUMENTS .....                                              | 45 |
| 4.4.3 TEST PROCEDURES .....                                          | 45 |
| 4.4.4 DEVIATION FROM TEST STANDARD .....                             | 45 |
| 4.4.5 TEST SETUP .....                                               | 45 |
| 4.4.6 EUT OPERATING CONDITIONS .....                                 | 46 |
| 4.4.7 TEST RESULTS .....                                             | 47 |
| 4.5 POWER SPECTRAL DENSITY MEASUREMENT .....                         | 50 |
| 4.5.1 LIMITS OF POWER SPECTRAL DENSITY MEASUREMENT .....             | 50 |
| 4.5.2 TEST INSTRUMENTS .....                                         | 50 |
| 4.5.3 TEST PROCEDURE .....                                           | 50 |
| 4.5.4 DEVIATION FROM TEST STANDARD .....                             | 50 |
| 4.5.5 TEST SETUP .....                                               | 50 |



A D T

|       |                                                             |    |
|-------|-------------------------------------------------------------|----|
| 4.5.6 | EUT OPERATING CONDITION.....                                | 50 |
| 4.5.7 | TEST RESULTS.....                                           | 51 |
| 4.6   | CONDUCTED OUT-BAND EMISSION MEASUREMENT.....                | 52 |
| 4.6.1 | LIMITS OF CONDUCTED OUT-BAND EMISSION MEASUREMENT.....      | 52 |
| 4.6.2 | TEST INSTRUMENTS.....                                       | 52 |
| 4.6.3 | TEST PROCEDURE.....                                         | 52 |
| 4.6.4 | DEVIATION FROM TEST STANDARD.....                           | 53 |
| 4.6.5 | TEST SETUP.....                                             | 53 |
| 4.6.6 | EUT OPERATING CONDITION.....                                | 53 |
| 4.6.7 | TEST RESULTS.....                                           | 53 |
| 5.    | TEST TYPES AND RESULTS (FOR 5gHz, 5.725~5.850GHz Band)..... | 60 |
| 5.1   | CONDUCTED EMISSION MEASUREMENT.....                         | 60 |
| 5.1.1 | LIMITS OF CONDUCTED EMISSION MEASUREMENT.....               | 60 |
| 5.1.2 | TEST INSTRUMENTS.....                                       | 60 |
| 5.1.3 | TEST PROCEDURES.....                                        | 61 |
| 5.1.4 | DEVIATION FROM TEST STANDARD.....                           | 61 |
| 5.1.5 | TEST SETUP.....                                             | 61 |
| 5.1.6 | EUT OPERATING CONDITIONS.....                               | 62 |
| 5.1.7 | TEST RESULTS.....                                           | 63 |
| 5.2   | RADIATED AND BANDEDGE EMISSION MEASUREMENT.....             | 67 |
| 5.2.1 | LIMITS OF RADIATED AND BANDEDGE EMISSION MEASUREMENT.....   | 67 |
| 5.2.2 | TEST INSTRUMENTS.....                                       | 68 |
| 5.2.3 | TEST PROCEDURES.....                                        | 69 |
| 5.2.4 | DEVIATION FROM TEST STANDARD.....                           | 69 |
| 5.2.5 | TEST SETUP.....                                             | 70 |
| 5.2.6 | EUT OPERATING CONDITIONS.....                               | 70 |
| 5.2.7 | TEST RESULTS.....                                           | 71 |
| 5.3   | 6dB BANDWIDTH MEASUREMENT.....                              | 80 |
| 5.3.1 | LIMITS OF 6dB BANDWIDTH MEASUREMENT.....                    | 80 |
| 5.3.2 | TEST INSTRUMENTS.....                                       | 80 |
| 5.3.3 | TEST PROCEDURE.....                                         | 80 |
| 5.3.4 | DEVIATION FROM TEST STANDARD.....                           | 80 |
| 5.3.5 | TEST SETUP.....                                             | 80 |
| 5.3.6 | EUT OPERATING CONDITIONS.....                               | 80 |
| 5.3.7 | TEST RESULTS.....                                           | 81 |
| 5.4   | CONDUCTED OUTPUT POWER MEASUREMENT.....                     | 82 |
| 5.4.1 | LIMITS OF CONDUCTED OUTPUT POWER MEASUREMENT.....           | 82 |
| 5.4.2 | INSTRUMENTS.....                                            | 82 |
| 5.4.3 | TEST PROCEDURES.....                                        | 82 |
| 5.4.4 | DEVIATION FROM TEST STANDARD.....                           | 82 |
| 5.4.5 | TEST SETUP.....                                             | 82 |
| 5.4.6 | EUT OPERATING CONDITIONS.....                               | 82 |
| 5.4.7 | TEST RESULTS.....                                           | 84 |
| 5.5   | POWER SPECTRAL DENSITY MEASUREMENT.....                     | 87 |
| 5.5.1 | LIMITS OF POWER SPECTRAL DENSITY MEASUREMENT.....           | 87 |
| 5.5.2 | TEST INSTRUMENTS.....                                       | 87 |
| 5.5.3 | TEST PROCEDURE.....                                         | 87 |
| 5.5.4 | DEVIATION FROM TEST STANDARD.....                           | 87 |
| 5.5.5 | TEST SETUP.....                                             | 87 |
| 5.5.6 | EUT OPERATING CONDITION.....                                | 87 |
| 5.5.7 | TEST RESULTS.....                                           | 88 |
| 5.6   | CONDUCTED OUT-BAND EMISSION MEASUREMENT.....                | 89 |



A D T

|       |                                                                                            |    |
|-------|--------------------------------------------------------------------------------------------|----|
| 5.6.1 | LIMITS OF CONDUCTED OUT-BAND EMISSION MEASUREMENT.....                                     | 89 |
| 5.6.2 | TEST INSTRUMENTS.....                                                                      | 89 |
| 5.6.3 | TEST PROCEDURE.....                                                                        | 89 |
| 5.6.4 | DEVIATION FROM TEST STANDARD.....                                                          | 90 |
| 5.6.5 | TEST SETUP.....                                                                            | 90 |
| 5.6.6 | EUT OPERATING CONDITION.....                                                               | 90 |
| 5.6.7 | TEST RESULTS.....                                                                          | 90 |
| 6.    | PHOTOGRAPHS OF THE TEST CONFIGURATION.....                                                 | 96 |
| 7.    | INFORMATION ON THE TESTING LABORATORIES.....                                               | 97 |
| 8.    | APPENDIX A - MODIFICATIONS RECORDERS FOR ENGINEERING CHANGES<br>TO THE EUT BY THE LAB..... | 98 |



A D T

## RELEASE CONTROL RECORD

| ISSUE NO.   | REASON FOR CHANGE | DATE ISSUED   |
|-------------|-------------------|---------------|
| RF130328E02 | Original release  | June 06, 2013 |



## 1. CERTIFICATION

**PRODUCT:** N600 Dual Band Wireless Router  
**BRAND NAME:** TRENDnet  
**MODEL NO.:** TEW-751DR  
**TEST SAMPLE:** ENGINEERING SAMPLE  
**APPLICANT:** TRENDnet, Inc  
**TESTED:** Apr. 08 to 11, 2013  
**STANDARDS:** FCC Part 15, Subpart C (Section 15.247)  
ANSI C63.10-2009

The above equipment (Model: TEW-751DR) has been tested by **Bureau Veritas Consumer Products Services (H.K.) Ltd., Taoyuan Branch**, and found compliance with the requirement of the above standards. The test record, data evaluation & Equipment Under Test (EUT) configurations represented herein are true and accurate accounts of the measurements of the sample's EMC characteristics under the conditions specified in this report.

**PREPARED BY :**  , **DATE:** June 06, 2013  
( Elsie Hsu, Specialist )

**APPROVED BY :**  , **DATE:** June 06, 2013  
( May Chen, Manager )



A D T

## 2. SUMMARY OF TEST RESULTS

The EUT has been tested according to the following specifications:

For 2.4GHz, 2400~2483.5MHz Band

| APPLIED STANDARD: FCC PART 15, SUBPART C (SECTION 15.247) |                             |        |                                                                                            |
|-----------------------------------------------------------|-----------------------------|--------|--------------------------------------------------------------------------------------------|
| STANDARD SECTION                                          | TEST TYPE                   | RESULT | REMARK                                                                                     |
| 15.207                                                    | AC Power Conducted Emission | PASS   | Meet the requirement of limit. Minimum passing margin is -8.18dB at 4.66016MHz             |
| 15.247(d)<br>15.209                                       | Radiated Emissions          | PASS   | Meet the requirement of limit. Minimum passing margin is -0.5dB at 7386.00MHz & 2390.00MHz |
| 15.247(d)                                                 | Band Edge Measurement       | PASS   | Meet the requirement of limit.                                                             |
| 15.247(a)(2)                                              | 6dB bandwidth               | PASS   | Meet the requirement of limit.                                                             |
| 15.247(b)                                                 | Conducted Output power      | PASS   | Meet the requirement of limit.                                                             |
| 15.247(e)                                                 | Power Spectral Density      | PASS   | Meet the requirement of limit.                                                             |
| 15.203                                                    | Antenna Requirement         | PASS   | No antenna connector is used.                                                              |

For 5GHz, 5725~5850MHz Band

| APPLIED STANDARD: FCC PART 15, SUBPART C (SECTION 15.247) |                             |        |                                                                                |
|-----------------------------------------------------------|-----------------------------|--------|--------------------------------------------------------------------------------|
| STANDARD SECTION                                          | TEST TYPE                   | RESULT | REMARK                                                                         |
| 15.207                                                    | AC Power Conducted Emission | PASS   | Meet the requirement of limit. Minimum passing margin is -6.37dB at 4.65625MHz |
| 15.247(d)<br>15.209                                       | Radiated Emissions          | PASS   | Meet the requirement of limit. Minimum passing margin is -0.6dB at 5350.00MHz  |
| 15.247(d)                                                 | Band Edge Measurement       | PASS   | Meet the requirement of limit.                                                 |
| 15.247(a)(2)                                              | 6dB bandwidth               | PASS   | Meet the requirement of limit.                                                 |
| 15.247(b)                                                 | Conducted Output power      | PASS   | Meet the requirement of limit.                                                 |
| 15.247(e)                                                 | Power Spectral Density      | PASS   | Meet the requirement of limit.                                                 |
| 15.203                                                    | Antenna Requirement         | PASS   | Antenna connectors is I-PEX not a standard connector.                          |

**NOTE:** The EUT was operating in 2.400 ~ 2.4835GHz, 5.15~5.25GHz and 5.725~5.850GHz frequencies band. This report was recorded the RF parameters including 2.400 ~ 2.4835GHz and 5.725~5.850GHz. For the 5.15~5.25GHz RF parameters was recorded in another test report.



A D T

## 2.1 MEASUREMENT UNCERTAINTY

Where relevant, the following measurement uncertainty levels have been estimated for tests performed on the EUT as specified in CISPR 16-4-2:

This uncertainty represents an expanded uncertainty expressed at approximately the 95% confidence level using a coverage factor of  $k=2$ .

| Measurement                       | Value   |
|-----------------------------------|---------|
| Conducted emissions               | 2.98 dB |
| Radiated emissions (30MHz-1GHz)   | 5.59 dB |
| Radiated emissions (1GHz -6GHz)   | 3.73 dB |
| Radiated emissions (6GHz -18GHz)  | 3.90 dB |
| Radiated emissions (18GHz -40GHz) | 4.11 dB |





A D T

### 3. GENERAL INFORMATION

#### 3.1 GENERAL DESCRIPTION OF EUT

|                              |                                                                                                                                                                                    |
|------------------------------|------------------------------------------------------------------------------------------------------------------------------------------------------------------------------------|
| <b>PRODUCT</b>               | N600 Dual Band Wireless Router                                                                                                                                                     |
| <b>MODEL NO.</b>             | TEW-751DR                                                                                                                                                                          |
| <b>POWER SUPPLY</b>          | DC 12V from power adapter                                                                                                                                                          |
| <b>MODULATION TYPE</b>       | CCK, DQPSK, DBPSK for DSSS<br>64QAM, 16QAM, QPSK, BPSK for OFDM                                                                                                                    |
| <b>MODULATION TECHNOLOGY</b> | DSSS, OFDM                                                                                                                                                                         |
| <b>TRANSFER RATE</b>         | 802.11b: up to 11Mbps<br>802.11a / g: up to 54Mbps<br>802.11n: up to 300Mbps                                                                                                       |
| <b>OPERATING FREQUENCY</b>   | <b>For 15.407</b><br>802.11a/n: 5.18 ~ 5.24GHz                                                                                                                                     |
|                              | <b>For 15.247</b><br>802.11b/g/n: 2.412 ~ 2.462GHz<br>802.11a/n: 5.745 ~ 5.825GHz                                                                                                  |
| <b>NUMBER OF CHANNEL</b>     | <b>For 15.407</b><br>4 for 802.11a, 802.11n (HT20)<br>2 for 802.11n (HT40)                                                                                                         |
|                              | <b>For 15.247 (2.4GHz)</b><br>11 for 802.11b, 802.11g, 802.11n (HT20)<br>7 for 802.11n (HT40)<br><b>For 15.247 (5GHz)</b><br>5 for 802.11a, 802.11n (HT20)<br>2 for 802.11n (HT40) |

|                             |                                                                                                                                                                                                                                                                                                                                                |
|-----------------------------|------------------------------------------------------------------------------------------------------------------------------------------------------------------------------------------------------------------------------------------------------------------------------------------------------------------------------------------------|
| <b>MAXIMUM OUTPUT POWER</b> | <b>For 15.407</b><br>802.11a: 37.931mW<br>802.11n (HT20): 30.729mW<br>802.11n (HT40): 43.860mW<br><b>For 15.247 (2.4GHz)</b><br>802.11b: 188.799mW<br>802.11g: 268.534mW<br>802.11n (HT20): 475.999mW<br>802.11n (HT40): 274.533mW<br><b>For 15.247 (5GHz)</b><br>802.11a: 359.749mW<br>802.11n (HT20): 700.492mW<br>802.11n (HT40): 654.822mW |
| <b>ANTENNA TYPE</b>         | Please see NOTE                                                                                                                                                                                                                                                                                                                                |
| <b>DATA CABLE</b>           | NA                                                                                                                                                                                                                                                                                                                                             |
| <b>I/O PORTS</b>            | Refer to user's manual                                                                                                                                                                                                                                                                                                                         |
| <b>ASSOCIATED DEVICES</b>   | Adapter x 1                                                                                                                                                                                                                                                                                                                                    |

**NOTE:**

- The EUT must be supplied with a power adapter and following two different model names could be chosen:

| No. | Brand | Model No.       | Spec.                                                                                  |
|-----|-------|-----------------|----------------------------------------------------------------------------------------|
| 1   | LEI   | MU12AB120100-A1 | Input: 100-240V, 0.4A, 50-60Hz<br>Output: 12V, 1A<br>DC output cable(1.2m, unshielded) |
| 2   | AMIGO | AMS9-1201000FC2 | Input: 100-240V, 0.5A, 50-60Hz<br>Output: 12V, 1A<br>DC output cable(1.2m, unshielded) |

- The EUT was pre-tested for radiated test under following test modes:

| Pre-test Mode | Power                 |
|---------------|-----------------------|
| Mode A        | With adapter 1        |
| <b>Mode B</b> | <b>With adapter 2</b> |

From the above modes, the worst radiated test was found in **Mode B**. Therefore only the test data of the mode was recorded in this report.



A D T

3. The antennas provided to the EUT, please refer to the following table:

| For 2.4GHz          |                |                       |                                  |                 |           |                              |                 |                   |
|---------------------|----------------|-----------------------|----------------------------------|-----------------|-----------|------------------------------|-----------------|-------------------|
| Transmitter Circuit | Brand          | Model name            | Gain (dBi)<br>Include cable loss | Antenna Type    | Connector | Frequency range (MHz to MHz) | Cable Loss (dB) | Cable Length (cm) |
| Chain (0)           | NA             | NA                    | 0.02                             | printing        | NA        | 2400~2500                    | NA              | NA                |
| Chain (1)           | NA             | NA                    | 1.12                             | printing        | NA        | 2400~2500                    | NA              | NA                |
| For 5GHz            |                |                       |                                  |                 |           |                              |                 |                   |
| Transmitter Circuit | Brand          | Model name            | Gain (dBi)<br>Include cable loss | Antenna Type    | Connector | Frequency range (MHz to MHz) | Cable Loss (dB) | Cable Length (cm) |
| Chain (0)           | MAG.LA<br>YERS | PCA-2010-5<br>G0C1-A8 | 4.86                             | FR4<br>assembly | I-PEX     | 5150~5850                    | 0.21            | 6.35              |
| Chain (1)           | MAG.LA<br>YERS | PCA-2010-5<br>G0C1-A7 | 4.55                             | FR4<br>assembly | I-PEX     | 5150~5850                    | 0.26            | 7.75              |

Note: For 802.11abg mode will fix transmission on Chain (0).

4. The EUT incorporates a MIMO function without beam forming.

| MODULATION MODE | TX/RX FUNCTION |
|-----------------|----------------|
| 802.11a         | 1TX/1RX        |
| 802.11b         | 1TX/1RX        |
| 802.11g         | 1TX/1RX        |
| 802.11n (HT20)  | 2TX/2RX        |
| 802.11n (HT40)  | 2TX/2RX        |

- Spurious emission of the simultaneous operation (2.4GHz & 5GHz) has been evaluated and no non-compliance was found.
- When the EUT operating in 802.11n, the software operation, which is defined by manufacturer, MCS (Modulation and Coding Schemes) from 0 to 15.
- The above EUT information was declared by the manufacturer and for more detailed features description, please refer to the manufacturer's specifications or User's Manual.

### 3.2 DESCRIPTION OF TEST MODES

#### Operated in 2400 ~ 2483.5MHz band:

11 channels are provided for 802.11b, 802.11g, 802.11n (HT20):

| CHANNEL | FREQUENCY | CHANNEL | FREQUENCY |
|---------|-----------|---------|-----------|
| 1       | 2412MHz   | 7       | 2442MHz   |
| 2       | 2417MHz   | 8       | 2447MHz   |
| 3       | 2422MHz   | 9       | 2452MHz   |
| 4       | 2427MHz   | 10      | 2457MHz   |
| 5       | 2432MHz   | 11      | 2462MHz   |
| 6       | 2437MHz   |         |           |

7 channels are provided for 802.11n (HT40):

| CHANNEL | FREQUENCY | CHANNEL | FREQUENCY |
|---------|-----------|---------|-----------|
| 3       | 2422MHz   | 7       | 2442MHz   |
| 4       | 2427MHz   | 8       | 2447MHz   |
| 5       | 2432MHz   | 9       | 2452MHz   |
| 6       | 2437MHz   |         |           |

#### Operated in 5725 ~ 5850MHz band:

5 channels are provided for 802.11a, 802.11n (HT20):

| CHANNEL | FREQUENCY | CHANNEL | FREQUENCY |
|---------|-----------|---------|-----------|
| 149     | 5745 MHz  | 161     | 5805 MHz  |
| 153     | 5765 MHz  | 165     | 5825 MHz  |
| 157     | 5785 MHz  |         |           |

2 channels are provided for 802.11n (HT40):

| CHANNEL | FREQUENCY |
|---------|-----------|
| 151     | 5755 MHz  |
| 159     | 5795 MHz  |



A D T

### 3.2.1 TEST MODE APPLICABILITY AND TESTED CHANNEL DETAIL

| EUT CONFIGURE MODE | APPLICABLE TO |         |         |      |    | DESCRIPTION          |
|--------------------|---------------|---------|---------|------|----|----------------------|
|                    | PLC           | RE < 1G | RE ≥ 1G | APCM | OB |                      |
| 1                  | √             | √       | √       | √    | √  | With power adapter 2 |
| 2                  | √             | -       | -       | -    | -  | With power adapter 1 |

Where **PLC**: Power Line Conducted Emission      **RE < 1G**: Radiated Emission below 1GHz  
**RE ≥ 1G**: Radiated Emission above 1GHz      **APCM**: Antenna Port Conducted Measurement  
**OB**: Conducted Out-Band Emission Measurement

#### **POWER LINE CONDUCTED EMISSION TEST:**

- Pre-Scan has been conducted to determine the worst-case mode from all possible combinations between available modulations, data rates and antenna ports (if EUT with antenna diversity architecture).
- Following channel(s) was (were) selected for the final test as listed below.

| MODE                          | AVAILABLE CHANNEL | TESTED CHANNEL | MODULATION TECHNOLOGY | MODULATION TYPE | DATA RATE (Mbps) |
|-------------------------------|-------------------|----------------|-----------------------|-----------------|------------------|
| For 2.4 GHz<br>802.11n (HT20) | 1 to 11           | 6              | OFDM                  | BPSK            | 6.5              |
| For 5 GHz<br>802.11n (HT20)   | 149 to 165        | 165            | OFDM                  | BPSK            | 6.5              |

#### **RADIATED EMISSION TEST (BELOW 1 GHz):**

- Pre-Scan has been conducted to determine the worst-case mode from all possible combinations between available modulations, data rates and antenna ports (if EUT with antenna diversity architecture).
- Following channel(s) was (were) selected for the final test as listed below.

| MODE                          | AVAILABLE CHANNEL | TESTED CHANNEL | MODULATION TECHNOLOGY | MODULATION TYPE | DATA RATE (Mbps) |
|-------------------------------|-------------------|----------------|-----------------------|-----------------|------------------|
| For 2.4 GHz<br>802.11n (HT20) | 1 to 11           | 6              | OFDM                  | BPSK            | 6.5              |
| For 5 GHz<br>802.11n (HT20)   | 149 to 165        | 165            | OFDM                  | BPSK            | 6.5              |



A D T

**RADIATED EMISSION TEST (ABOVE 1 GHz):**

- Pre-Scan has been conducted to determine the worst-case mode from all possible combinations between available modulations, data rates and antenna ports (if EUT with antenna diversity architecture).
- Following channel(s) was (were) selected for the final test as listed below.

| MODE                          | AVAILABLE CHANNEL | TESTED CHANNEL | MODULATION TECHNOLOGY | MODULATION TYPE | DATA RATE (Mbps) |
|-------------------------------|-------------------|----------------|-----------------------|-----------------|------------------|
| 802.11b                       | 1 to 11           | 1, 6, 11       | DSSS                  | DBPSK           | 1                |
| 802.11g                       | 1 to 11           | 1, 6, 11       | OFDM                  | BPSK            | 6                |
| For 2.4 GHz<br>802.11n (HT20) | 1 to 11           | 1, 6, 11       | OFDM                  | BPSK            | 6.5              |
| For 2.4 GHz<br>802.11n (HT40) | 3 to 9            | 3, 6, 9        | OFDM                  | BPSK            | 13.5             |
| 802.11a                       | 149 to 165        | 149, 157, 165  | OFDM                  | BPSK            | 6                |
| For 5 GHz<br>802.11n (HT20)   | 149 to 165        | 149, 157, 165  | OFDM                  | BPSK            | 6.5              |
| For 5 GHz<br>802.11n (HT40)   | 151 to 159        | 151, 159       | OFDM                  | BPSK            | 13.5             |

**ANTENNA PORT CONDUCTED MEASUREMENT:**

- Pre-Scan has been conducted to determine the worst-case mode from all possible combinations between available modulations, data rates and antenna ports (if EUT with antenna diversity architecture).
- Following channel(s) was (were) selected for the final test as listed below.

| MODE                          | AVAILABLE CHANNEL | TESTED CHANNEL | MODULATION TECHNOLOGY | MODULATION TYPE | DATA RATE (Mbps) |
|-------------------------------|-------------------|----------------|-----------------------|-----------------|------------------|
| 802.11b                       | 1 to 11           | 1, 6, 11       | DSSS                  | DBPSK           | 1                |
| 802.11g                       | 1 to 11           | 1, 6, 11       | OFDM                  | BPSK            | 6                |
| For 2.4 GHz<br>802.11n (HT20) | 1 to 11           | 1, 6, 11       | OFDM                  | BPSK            | 6.5              |
| For 2.4 GHz<br>802.11n (HT40) | 3 to 9            | 3, 6, 9        | OFDM                  | BPSK            | 13.5             |
| 802.11a                       | 149 to 165        | 149, 157, 165  | OFDM                  | BPSK            | 6                |
| For 5 GHz<br>802.11n (HT20)   | 149 to 165        | 149, 157, 165  | OFDM                  | BPSK            | 6.5              |
| For 5 GHz<br>802.11n (HT40)   | 151 to 159        | 151, 159       | OFDM                  | BPSK            | 13.5             |



A D T

**CONDUCTED OUT-BAND EMISSION MEASUREMENT:**

- Pre-Scan has been conducted to determine the worst-case mode from all possible combinations between available modulations, data rates and antenna ports (if EUT with antenna diversity architecture).
- Following channel(s) was (were) selected for the final test as listed below.

| MODE                          | AVAILABLE CHANNEL | TESTED CHANNEL | MODULATION TECHNOLOGY | MODULATION TYPE | DATA RATE (Mbps) |
|-------------------------------|-------------------|----------------|-----------------------|-----------------|------------------|
| 802.11b                       | 1 to 11           | 1, 6, 11       | DSSS                  | DBPSK           | 1                |
| 802.11g                       | 1 to 11           | 1, 6, 11       | OFDM                  | BPSK            | 6                |
| For 2.4 GHz<br>802.11n (HT20) | 1 to 11           | 1, 6, 11       | OFDM                  | BPSK            | 6.5              |
| For 2.4 GHz<br>802.11n (HT40) | 3 to 9            | 3, 6, 9        | OFDM                  | BPSK            | 13.5             |
| 802.11a                       | 149 to 165        | 149, 157, 165  | OFDM                  | BPSK            | 6                |
| For 5 GHz<br>802.11n (HT20)   | 149 to 165        | 149, 157, 165  | OFDM                  | BPSK            | 6.5              |
| For 5 GHz<br>802.11n (HT40)   | 151 to 159        | 151, 159       | OFDM                  | BPSK            | 13.5             |

**TEST CONDITION:**

| APPLICABLE TO      | ENVIRONMENTAL CONDITIONS | INPUT POWER  | TESTED BY    |
|--------------------|--------------------------|--------------|--------------|
| PLC                | 24deg. C, 66%RH          | 120Vac, 60Hz | Gavin Peng   |
| RE<1G              | 24deg. C, 67%RH          | 120Vac, 60Hz | Robert Cheng |
| RE <sup>3</sup> 1G | 23deg. C, 70%RH          | 120Vac, 60Hz | Robert Cheng |
| APCM               | 25deg. C, 60%RH          | 120Vac, 60Hz | James Chan   |
| OB                 | 25deg. C, 60%RH          | 120Vac, 60Hz | James Chan   |

### **3.3 GENERAL DESCRIPTION OF APPLIED STANDARDS**

The EUT is a RF product. According to the specifications of the manufacturer, it must comply with the requirements of the following standards:

**FCC Part 15, Subpart C. (15.247)**

**558074 D01 DTS Meas Guidance v03r01**

**662911 D01 Multiple Transmitter Output v01 r02**

**ANSI C63.10-2009**

All test items have been performed and recorded as per the above standards.

**Note:** The EUT has been verified to comply with the requirements of FCC Part 15, Subpart B, Class B (DoC). The test report has been issued separately.





A D T

### 3.4 DESCRIPTION OF SUPPORT UNITS

The EUT has been tested as an independent unit together with other necessary accessories or support units. The following support units or accessories were used to form a representative test configuration during the tests.

| NO. | PRODUCT           | BRAND | MODEL NO. | SERIAL NO.    | FCC ID  |
|-----|-------------------|-------|-----------|---------------|---------|
| 1   | NOTEBOOK COMPUTER | DELL  | PP32LA    | FSLB32S       | FCC DoC |
| 2   | NOTEBOOK COMPUTER | DELL  | PP32LA    | GSLB32S       | FCC DoC |
| 3   | HUB               | ZyXEL | ES-116P   | S060H02000215 | FCC DoC |

| NO. | SIGNAL CABLE DESCRIPTION OF THE ABOVE SUPPORT UNITS |
|-----|-----------------------------------------------------|
| 1   | UTP cable (10m)                                     |
| 2   | UTP cable (10m)                                     |
| 3   | UTP cable (10m)                                     |

**NOTE:** All power cords of the above support units are non shielded (1.8m).

### 3.5 CONFIGURATION OF SYSTEM UNDER TEST

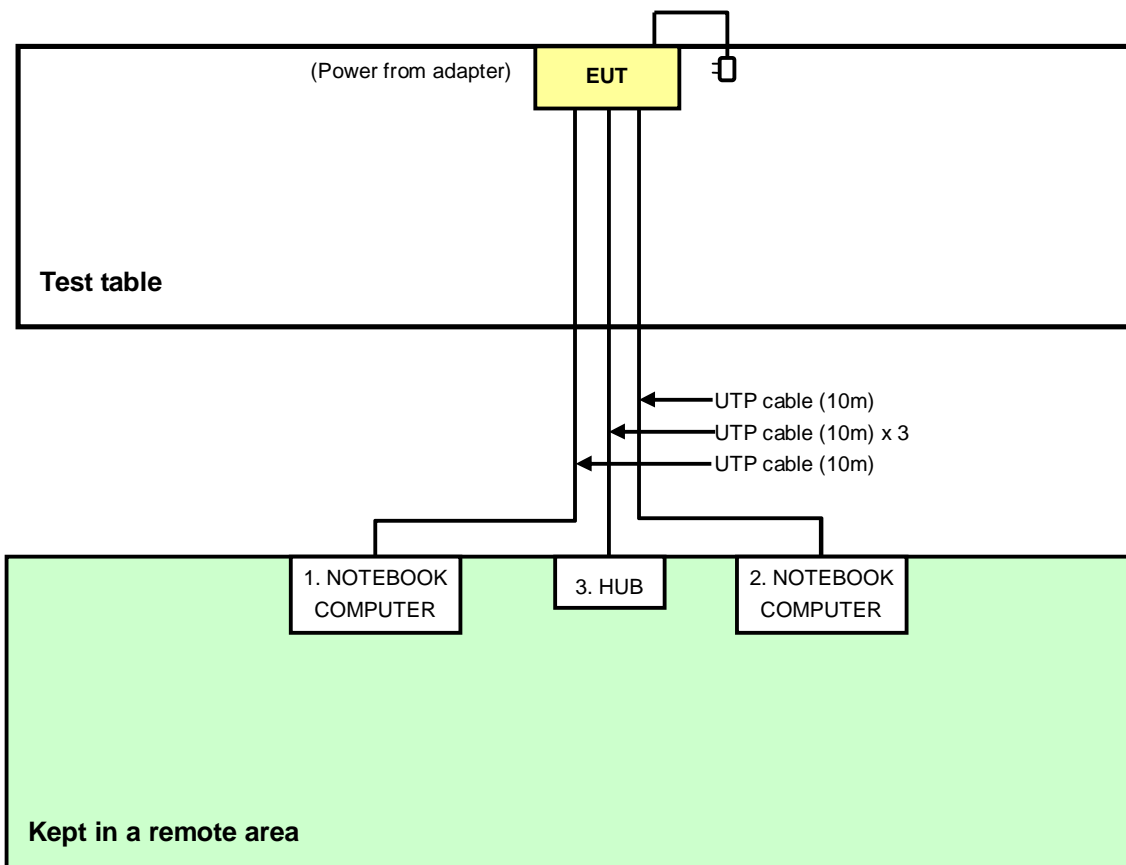



## 4. TEST TYPES AND RESULTS (FOR 2.4GHz, 2.400 ~ 2.4835GHz Band)

### 4.1 CONDUCTED EMISSION MEASUREMENT

#### 4.1.1 LIMITS OF CONDUCTED EMISSION MEASUREMENT

| FREQUENCY OF EMISSION (MHz) | CONDUCTED LIMIT (dB $\mu$ V) |          |
|-----------------------------|------------------------------|----------|
|                             | Quasi-peak                   | Average  |
| 0.15-0.5                    | 66 to 56                     | 56 to 46 |
| 0.5-5                       | 56                           | 46       |
| 5-30                        | 60                           | 50       |

- NOTE:**
1. The lower limit shall apply at the transition frequencies.
  2. The limit decreases in line with the logarithm of the frequency in the range of 0.15 to 0.50 MHz.

#### 4.1.2 TEST INSTRUMENTS

| DESCRIPTION & MANUFACTURER                                                     | MODEL NO.                   | SERIAL NO. | CALIBRATED DATE | CALIBRATED UNTIL |
|--------------------------------------------------------------------------------|-----------------------------|------------|-----------------|------------------|
| Test Receiver<br>ROHDE & SCHWARZ                                               | ESCS 30                     | 100287     | Feb. 28, 2013   | Feb. 27, 2014    |
| Line-Impedance<br>Stabilization Network<br>(for EUT)<br>SCHWARZBECK            | NSLK 8127                   | 8127-523   | Sep. 19, 2012   | Sep. 20, 2013    |
| Line-Impedance<br>Stabilization Network<br>(for Peripheral)<br>ROHDE & SCHWARZ | ESH3-Z5                     | 848773/004 | Oct. 29, 2012   | Oct. 28, 2013    |
| RF Cable<br>(JYEBAO)                                                           | 5DFB                        | COACAB-002 | Aug. 05, 2012   | Aug. 04, 2013    |
| 50 ohms Terminator                                                             | 50                          | 3          | Oct. 23, 2012   | Oct. 22, 2013    |
| Software<br>ADT                                                                | BV<br>ADT_Cond_V7.3.7<br>.3 | NA         | NA              | NA               |

**Note:**

1. The calibration interval of the above test instruments is 12 months and the calibrations are traceable to NML/ROC and NIST/USA.
2. The test was performed in Shielded Room No. A.
3. The VCCI Con A Registration No. is C-817.
4. Tested Date: Apr. 08, 2013

#### 4.1.3 TEST PROCEDURES

- a. The EUT was placed 0.4 meters from the conducting wall of the shielded room with EUT being connected to the power mains through a line impedance stabilization network (LISN). Other support units were connected to the power mains through another LISN.
- b. The two LISNs provide 50 ohm/ 50uH of coupling impedance for the measuring instrument.
- c. Both lines of the power mains connected to the EUT were checked for maximum conducted interference.
- d. The frequency range from 150kHz to 30MHz was searched. Emission levels under (Limit - 20dB) were not recorded.

#### NOTE:

1. The resolution bandwidth of test receiver is 9kHz for Quasi-peak detection (QP) & Average detection (AV).

#### 4.1.4 DEVIATION FROM TEST STANDARD

No deviation

#### 4.1.5 TEST SETUP

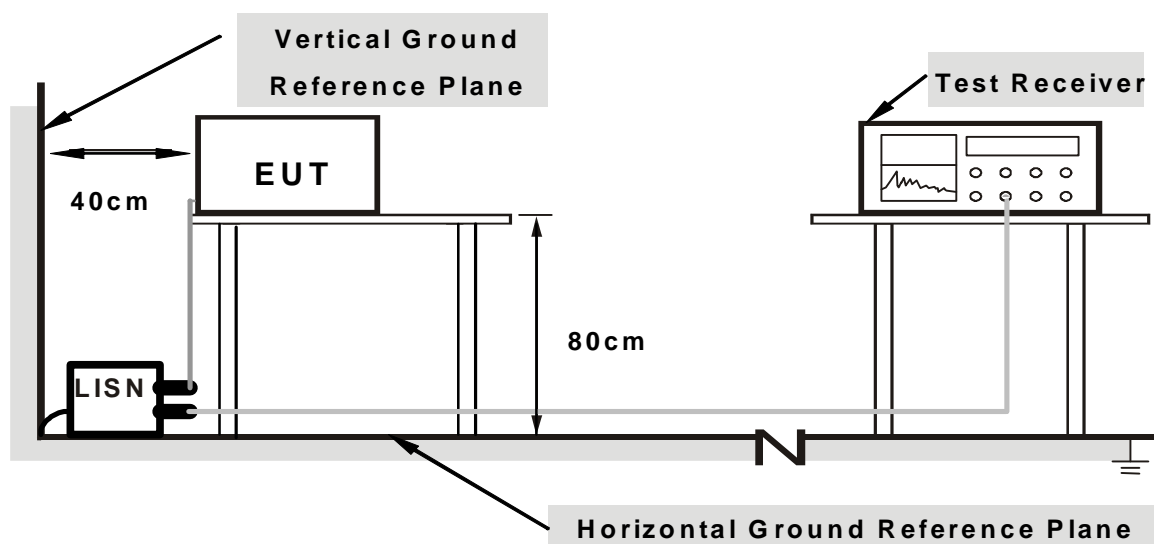

**Note: 1. Support units were connected to second LISN.**

For the actual test configuration, please refer to the related item – Photographs of the Test Configuration.



A D T

#### 4.1.6 EUT OPERATING CONDITIONS

1. Turn on the power of EUT.
2. The communication partner run test program “MT7620QA.exe” to enable EUT under transmission/receiving condition continuously at specific channel frequency.



A D T

#### 4.1.7 TEST RESULTS (MODE 1)

|              |          |                          |                                |
|--------------|----------|--------------------------|--------------------------------|
| <b>PHASE</b> | Line (L) | <b>DETECTOR FUNCTION</b> | Quasi-Peak (QP) / Average (AV) |
|--------------|----------|--------------------------|--------------------------------|

| No | Freq.<br>[MHz] | Corr.<br>Factor<br>(dB) | Reading Value |       | Emission Level |       | Limit     |       | Margin |        |
|----|----------------|-------------------------|---------------|-------|----------------|-------|-----------|-------|--------|--------|
|    |                |                         | [dB (uV)]     |       | [dB (uV)]      |       | [dB (uV)] |       | (dB)   |        |
|    |                |                         | Q.P.          | AV.   | Q.P.           | AV.   | Q.P.      | AV.   | Q.P.   | AV.    |
| 1  | 0.15391        | 0.10                    | 47.26         | 33.25 | 47.36          | 33.35 | 65.79     | 55.79 | -18.43 | -22.44 |
| 2  | 0.17734        | 0.10                    | 45.46         | 24.82 | 45.56          | 24.92 | 64.61     | 54.61 | -19.05 | -29.69 |
| 3  | 0.20859        | 0.11                    | 43.36         | 32.49 | 43.47          | 32.60 | 63.26     | 53.26 | -19.79 | -20.66 |
| 4  | 0.24766        | 0.12                    | 43.43         | 19.20 | 43.55          | 19.32 | 61.84     | 51.84 | -18.28 | -32.51 |
| 5  | 0.30625        | 0.14                    | 41.45         | 19.36 | 41.59          | 19.50 | 60.07     | 50.07 | -18.49 | -30.58 |
| 6  | 0.38828        | 0.16                    | 40.53         | 14.00 | 40.69          | 14.16 | 58.10     | 48.10 | -17.41 | -33.94 |
| 7  | 0.48984        | 0.16                    | 36.09         | 15.91 | 36.25          | 16.07 | 56.17     | 46.17 | -19.92 | -30.10 |
| 8  | 0.55234        | 0.17                    | 32.73         | 13.75 | 32.90          | 13.92 | 56.00     | 46.00 | -23.10 | -32.08 |
| 9  | 0.64219        | 0.17                    | 32.90         | 13.25 | 33.07          | 13.42 | 56.00     | 46.00 | -22.93 | -32.58 |
| 10 | 3.04297        | 0.28                    | 40.46         | 26.47 | 40.74          | 26.75 | 56.00     | 46.00 | -15.26 | -19.25 |

#### REMARKS:

1. Q.P. and AV. are abbreviations of quasi-peak and average individually.
2. The emission levels of other frequencies were very low against the limit.
3. Margin value = Emission level - Limit value
4. Correction factor = Insertion loss + Cable loss
5. Emission Level = Correction Factor + Reading Value.

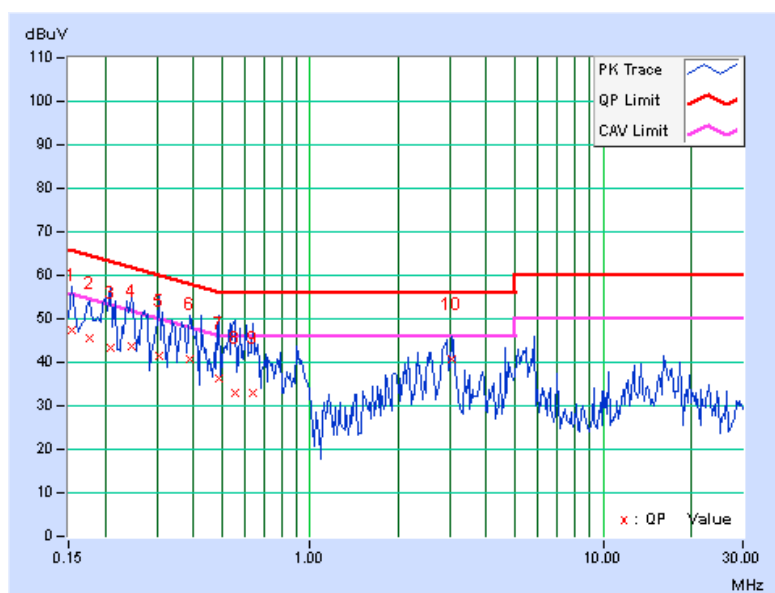

|              |             |                          |                                |
|--------------|-------------|--------------------------|--------------------------------|
| <b>PHASE</b> | Neutral (N) | <b>DETECTOR FUNCTION</b> | Quasi-Peak (QP) / Average (AV) |
|--------------|-------------|--------------------------|--------------------------------|

| No | Freq.<br>[MHz] | Corr.<br>Factor<br>(dB) | Reading Value<br>[dB (uV)] |       | Emission Level<br>[dB (uV)] |       | Limit<br>[dB (uV)] |       | Margin<br>(dB) |        |
|----|----------------|-------------------------|----------------------------|-------|-----------------------------|-------|--------------------|-------|----------------|--------|
|    |                |                         | Q.P.                       | AV.   | Q.P.                        | AV.   | Q.P.               | AV.   | Q.P.           | AV.    |
|    | 1              | 0.15000                 | 0.14                       | 48.82 | 26.75                       | 48.96 | 26.89              | 66.00 | 56.00          | -17.04 |
| 2  | 0.26719        | 0.16                    | 43.04                      | 24.72 | 43.20                       | 24.88 | 61.20              | 51.20 | -18.00         | -26.32 |
| 3  | 0.31797        | 0.17                    | 41.11                      | 21.54 | 41.28                       | 21.71 | 59.76              | 49.76 | -18.48         | -28.05 |
| 4  | 0.41953        | 0.19                    | 38.83                      | 25.28 | 39.02                       | 25.47 | 57.46              | 47.46 | -18.44         | -21.99 |
| 5  | 0.48203        | 0.19                    | 35.80                      | 17.96 | 35.99                       | 18.15 | 56.30              | 46.30 | -20.31         | -28.15 |
| 6  | 0.49375        | 0.19                    | 36.90                      | 12.87 | 37.09                       | 13.06 | 56.10              | 46.10 | -19.01         | -33.04 |
| 7  | 0.61875        | 0.20                    | 32.85                      | 10.64 | 33.05                       | 10.84 | 56.00              | 46.00 | -22.95         | -35.16 |
| 8  | 2.92188        | 0.31                    | 36.49                      | 23.32 | 36.80                       | 23.63 | 56.00              | 46.00 | -19.20         | -22.37 |

**REMARKS:**

1. Q.P. and AV. are abbreviations of quasi-peak and average individually.
2. The emission levels of other frequencies were very low against the limit.
3. Margin value = Emission level - Limit value
4. Correction factor = Insertion loss + Cable loss
5. Emission Level = Correction Factor + Reading Value.

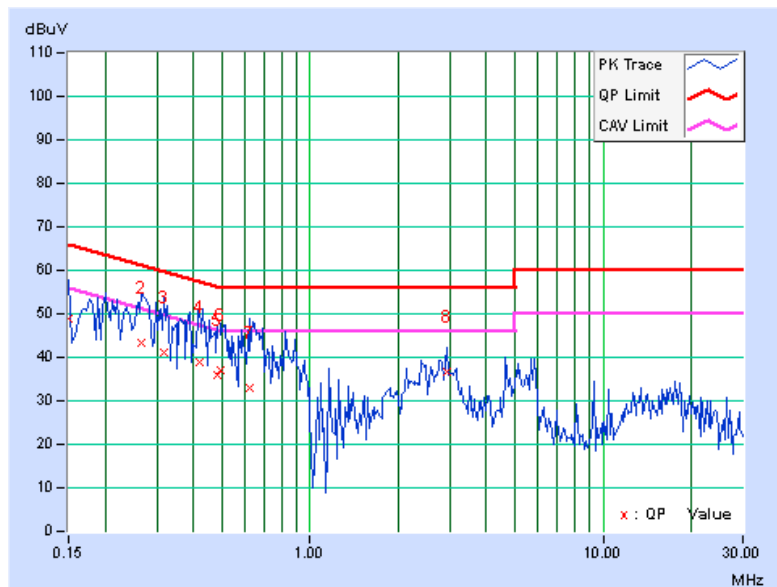

### 4.1.8 TEST RESULTS (MODE 2)

| PHASE | Line (L) | DETECTOR FUNCTION | Quasi-Peak (QP) / Average (AV) |
|-------|----------|-------------------|--------------------------------|
|-------|----------|-------------------|--------------------------------|

| No       | Freq. [MHz]    | Corr. Factor (dB) | Reading Value [dB (uV)] |              | Emission Level [dB (uV)] |              | Limit [dB (uV)] |              | Margin (dB)   |              |
|----------|----------------|-------------------|-------------------------|--------------|--------------------------|--------------|-----------------|--------------|---------------|--------------|
|          |                |                   | Q.P.                    | AV.          | Q.P.                     | AV.          | Q.P.            | AV.          | Q.P.          | AV.          |
|          | 1              | 0.16050           | 0.10                    | 47.52        | 39.61                    | 47.62        | 39.71           | 65.44        | 55.44         | -17.82       |
| 2        | 0.20078        | 0.11              | 46.81                   | 25.07        | 46.92                    | 25.18        | 63.58           | 53.58        | -16.66        | -28.40       |
| 3        | 0.27844        | 0.13              | 41.98                   | 29.02        | 42.11                    | 29.15        | 60.86           | 50.86        | -18.75        | -21.71       |
| 4        | 0.34922        | 0.15              | 39.80                   | 18.07        | 39.95                    | 18.22        | 58.98           | 48.98        | -19.03        | -30.76       |
| 5        | 0.38747        | 0.16              | 36.70                   | 25.83        | 36.86                    | 25.99        | 58.12           | 48.12        | -21.26        | -22.13       |
| 6        | 0.45078        | 0.16              | 35.99                   | 17.41        | 36.15                    | 17.57        | 56.86           | 46.86        | -20.71        | -29.29       |
| 7        | 0.55234        | 0.17              | 32.26                   | 17.73        | 32.43                    | 17.90        | 56.00           | 46.00        | -23.57        | -28.10       |
| <b>8</b> | <b>4.66016</b> | <b>0.35</b>       | <b>41.68</b>            | <b>37.47</b> | <b>42.03</b>             | <b>37.82</b> | <b>56.00</b>    | <b>46.00</b> | <b>-13.97</b> | <b>-8.18</b> |

**REMARKS:**

1. Q.P. and AV. are abbreviations of quasi-peak and average individually.
2. The emission levels of other frequencies were very low against the limit.
3. Margin value = Emission level - Limit value
4. Correction factor = Insertion loss + Cable loss
5. Emission Level = Correction Factor + Reading Value.

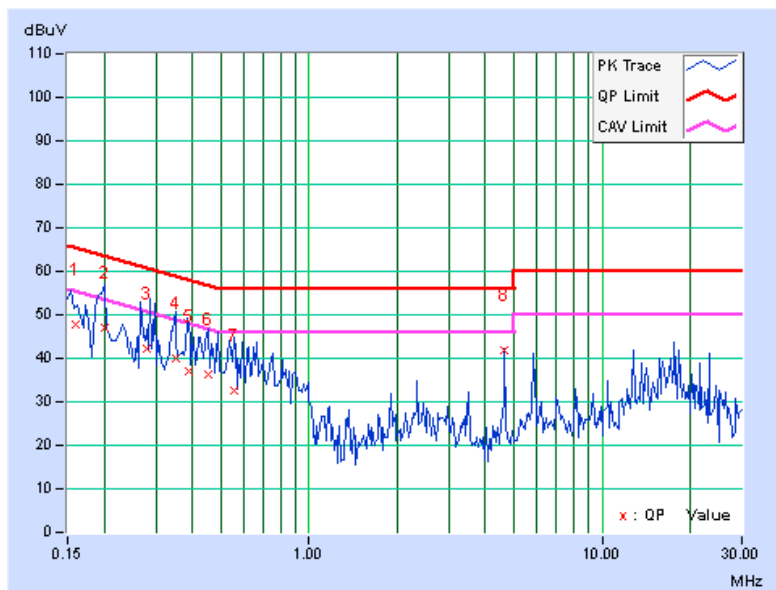



|              |             |                          |                                |
|--------------|-------------|--------------------------|--------------------------------|
| <b>PHASE</b> | Neutral (N) | <b>DETECTOR FUNCTION</b> | Quasi-Peak (QP) / Average (AV) |
|--------------|-------------|--------------------------|--------------------------------|

| No | Freq.<br>[MHz] | Corr.<br>Factor<br>(dB) | Reading Value<br>[dB (uV)] |       | Emission Level<br>[dB (uV)] |       | Limit<br>[dB (uV)] |       | Margin<br>(dB) |        |
|----|----------------|-------------------------|----------------------------|-------|-----------------------------|-------|--------------------|-------|----------------|--------|
|    |                |                         | Q.P.                       | AV.   | Q.P.                        | AV.   | Q.P.               | AV.   | Q.P.           | AV.    |
|    | 1              | 0.16694                 | 0.15                       | 46.77 | 38.67                       | 46.92 | 38.82              | 65.11 | 55.11          | -18.19 |
| 2  | 0.21534        | 0.15                    | 43.36                      | 32.65 | 43.51                       | 32.80 | 63.00              | 53.00 | -19.48         | -20.19 |
| 3  | 0.27563        | 0.17                    | 42.84                      | 28.68 | 43.01                       | 28.85 | 60.95              | 50.95 | -17.94         | -22.10 |
| 4  | 0.38459        | 0.19                    | 38.00                      | 24.66 | 38.19                       | 24.85 | 58.18              | 48.18 | -19.99         | -23.33 |
| 5  | 0.46641        | 0.19                    | 37.64                      | 20.48 | 37.83                       | 20.67 | 56.58              | 46.58 | -18.74         | -25.90 |
| 6  | 0.57969        | 0.20                    | 36.60                      | 19.75 | 36.80                       | 19.95 | 56.00              | 46.00 | -19.20         | -26.05 |

**REMARKS:**

1. Q.P. and AV. are abbreviations of quasi-peak and average individually.
2. The emission levels of other frequencies were very low against the limit.
3. Margin value = Emission level - Limit value
4. Correction factor = Insertion loss + Cable loss
5. Emission Level = Correction Factor + Reading Value.

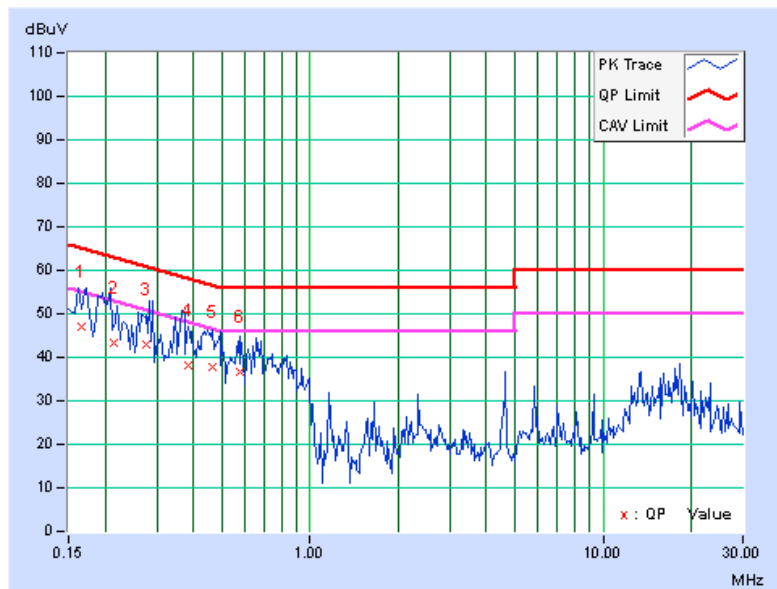



A D T

## 4.2 RADIATED EMISSION AND BANDEGE MEASUREMENT

### 4.2.1 LIMITS OF RADIATED EMISSION AND BANDEGE MEASUREMENT

Radiated emissions which fall in the restricted bands must comply with the radiated emission limits specified as below table. Other emissions shall be at least 30dB below the highest level of the desired power:

| Frequencies (MHz) | Field strength (microvolts/meter) | Measurement distance (meters) |
|-------------------|-----------------------------------|-------------------------------|
| 0.009-0.490       | 2400/F(kHz)                       | 300                           |
| 0.490-1.705       | 24000/F(kHz)                      | 30                            |
| 1.705-30.0        | 30                                | 30                            |
| 30-88             | 100                               | 3                             |
| 88-216            | 150                               | 3                             |
| 216-960           | 200                               | 3                             |
| Above 960         | 500                               | 3                             |

**NOTE:**

1. The lower limit shall apply at the transition frequencies.
2. Emission level (dBuV/m) = 20 log Emission level (uV/m).
3. For frequencies above 1000MHz, the field strength limits are based on average detector, however, the peak field strength of any emission shall not exceed the maximum permitted average limits, specified above by more than 20dB under any condition of modulation.



A D T

## 4.2.2 TEST INSTRUMENTS

| DESCRIPTION & MANUFACTURER              | MODEL NO.                | SERIAL NO.                          | CALIBRATED DATE | CALIBRATED UNTIL |
|-----------------------------------------|--------------------------|-------------------------------------|-----------------|------------------|
| Spectrum Analyzer<br>Agilent            | E4446A                   | MY48250253                          | Sep. 03, 2012   | Sep. 02, 2013    |
| MXE EMI Receiver<br>Agilent             | N9038A                   | MY51210105                          | Jan. 29, 2013   | Jan. 28, 2014    |
| Pre-Amplifier<br>Mini-Circuits          | ZFL-1000VH2<br>B         | AMP-ZFL-03                          | Nov. 14, 2012   | Nov. 13, 2013    |
| Pre-Amplifier<br>Agilent                | 8449B                    | 3008A02578                          | June 26, 2012   | June 25, 2013    |
| Pre-Amplifier<br>SPACEK LABS            | SLKKa-48-6               | 9K16                                | Nov. 14, 2012   | Nov. 13, 2013    |
| Trilog Broadband Antenna<br>SCHWARZBECK | VULB 9168                | 9168-360                            | Mar. 19, 2013   | Mar. 18, 2014    |
| Horn_Antenna<br>AISI                    | AIH.8018                 | 0000320091110                       | Nov. 19, 2012   | Nov. 18, 2013    |
| Horn_Antenna<br>SCHWARZBECK             | BBHA 9170                | 9170-424                            | Oct. 12, 2012   | Oct. 11, 2013    |
| RF Cable                                | NA                       | RF104-201<br>RF104-203<br>RF104-204 | Dec. 25, 2012   | Dec. 24, 2013    |
| RF Cable                                | NA                       | CHGCAB_001                          | Oct. 06, 2012   | Oct. 05, 2013    |
| Software                                | ADT_Radiated<br>_V8.7.05 | NA                                  | NA              | NA               |
| Antenna Tower & Turn Table<br>CT        | NA                       | NA                                  | NA              | NA               |

### Note:

1. The calibration interval of the above test instruments is 12 months and the calibrations are traceable to NML/ROC and NIST/USA.
2. The horn antenna, preamplifier (model: 8449B) are used only for the measurement of emission frequency above 1GHz if tested.
- 3 The test was performed in 966 Chamber No. G.
4. The FCC Site Registration No. is 966073.
- 5 The VCCI Site Registration No. is G-137.
- 6 The CANADA Site Registration No. is IC 7450H-2.
- 7 Tested Date: Apr. 10, 2013

#### 4.2.3 TEST PROCEDURES

- a. The EUT was placed on the top of a rotating table 0.8 meters above the ground at 3 meter chamber room for test. The table was rotated 360 degrees to determine the position of the highest radiation.
- b. The EUT was set 3 meters away from the interference-receiving antenna, which was mounted on the top of a variable-height antenna tower.
- c. The height of antenna is varied from one meter to four meters above the ground to determine the maximum value of the field strength. Both horizontal and vertical polarizations of the antenna are set to make the measurement.
- d. For each suspected emission, the EUT was arranged to its worst case and then the antenna was tuned to heights from 1 meter to 4 meters and the rotatable table was turned from 0 degrees to 360 degrees to find the maximum reading.
- e. The test-receiver system was set to quasi-peak detect function and specified bandwidth with maximum hold mode when the test frequency is below 1 GHz.
- f. The test-receiver system was set to peak and average detect function and specified bandwidth with maximum hold mode when the test frequency is above 1 GHz. If the peak reading value also meets average limit, measurement with the average detector is unnecessary.

**NOTE:**

1. The resolution bandwidth and video bandwidth of test receiver/spectrum analyzer is 120kHz for Quasi-peak detection (QP) at frequency below 1GHz.
2. The resolution bandwidth of test receiver/spectrum analyzer is 1 MHz and the video bandwidth is 3 MHz for Peak detection (PK) at frequency above 1GHz.
3. The resolution bandwidth of test receiver/spectrum analyzer is 1 MHz and the video bandwidth is 10 Hz for Average detection (AV) at frequency above 1GHz.
4. All modes of operation were investigated and the worst-case emissions are reported.

#### 4.2.4 DEVIATION FROM TEST STANDARD

No deviation

#### 4.2.5 TEST SETUP

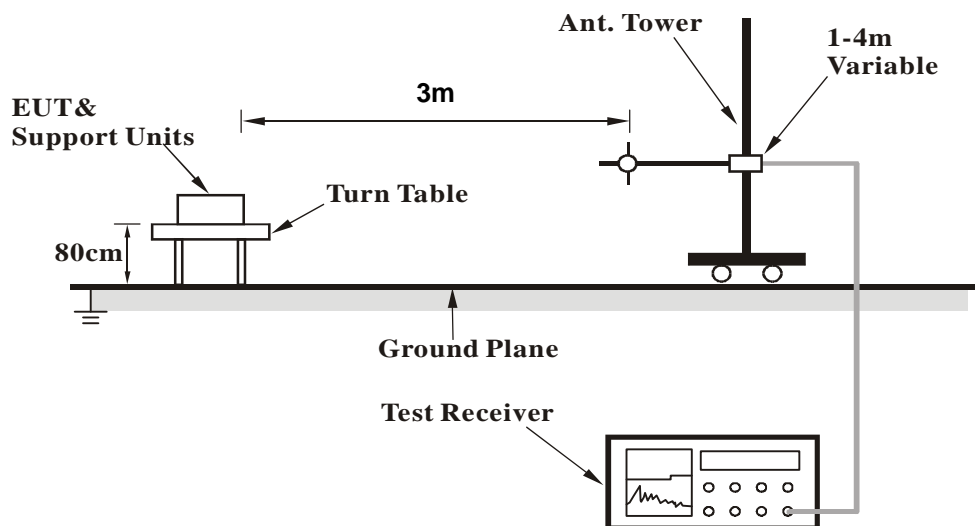

For the actual test configuration, please refer to the related item – Photographs of the Test Configuration.

#### 4.2.6 EUT OPERATING CONDITIONS

Same as 4.1.6

## 4.2.7 TEST RESULTS

### BELOW 1GHz WORST-CASE DATA

#### 802.11n (HT20)

|                        |              |                          |                 |
|------------------------|--------------|--------------------------|-----------------|
| <b>CHANNEL</b>         | TX Channel 6 | <b>DETECTOR FUNCTION</b> | Quasi-Peak (QP) |
| <b>FREQUENCY RANGE</b> | Below 1GHz   |                          |                 |

| ANTENNA POLARITY & TEST DISTANCE: HORIZONTAL AT 3 M |             |                         |                |             |                    |                      |                  |                          |
|-----------------------------------------------------|-------------|-------------------------|----------------|-------------|--------------------|----------------------|------------------|--------------------------|
| NO.                                                 | FREQ. (MHz) | EMISSION LEVEL (dBuV/m) | LIMIT (dBuV/m) | MARGIN (dB) | ANTENNA HEIGHT (m) | TABLE ANGLE (Degree) | RAW VALUE (dBuV) | CORRECTION FACTOR (dB/m) |
| 1                                                   | 104.74      | 30.2 QP                 | 43.5           | -13.3       | 1.50 H             | 360                  | 47.57            | -17.33                   |
| 2                                                   | 148.10      | 33.9 QP                 | 43.5           | -9.6        | 2.00 H             | 64                   | 47.72            | -13.85                   |
| 3                                                   | 579.99      | 30.5 QP                 | 46.0           | -15.5       | 1.00 H             | 360                  | 36.62            | -6.14                    |
| 4                                                   | 625.00      | 34.1 QP                 | 46.0           | -11.9       | 1.00 H             | 360                  | 38.94            | -4.85                    |
| 5                                                   | 676.70      | 34.3 QP                 | 46.0           | -11.7       | 1.00 H             | 360                  | 38.66            | -4.32                    |
| 6                                                   | 750.03      | 32.6 QP                 | 46.0           | -13.4       | 1.00 H             | 45                   | 35.08            | -2.45                    |
| ANTENNA POLARITY & TEST DISTANCE: VERTICAL AT 3 M   |             |                         |                |             |                    |                      |                  |                          |
| NO.                                                 | FREQ. (MHz) | EMISSION LEVEL (dBuV/m) | LIMIT (dBuV/m) | MARGIN (dB) | ANTENNA HEIGHT (m) | TABLE ANGLE (Degree) | RAW VALUE (dBuV) | CORRECTION FACTOR (dB/m) |
| 1                                                   | 77.19       | 30.1 QP                 | 40.0           | -10.0       | 1.00 V             | 301                  | 47.80            | -17.75                   |
| 2                                                   | 483.43      | 30.7 QP                 | 46.0           | -15.3       | 1.00 V             | 327                  | 38.91            | -8.23                    |
| 3                                                   | 531.64      | 35.3 QP                 | 46.0           | -10.7       | 1.00 V             | 252                  | 42.72            | -7.40                    |
| 4                                                   | 579.99      | 33.4 QP                 | 46.0           | -12.6       | 2.00 V             | 360                  | 39.52            | -6.14                    |
| 5                                                   | 628.30      | 36.5 QP                 | 46.0           | -9.6        | 1.50 V             | 311                  | 41.29            | -4.84                    |
| 6                                                   | 676.60      | 32.8 QP                 | 46.0           | -13.2       | 1.50 V             | 257                  | 37.11            | -4.32                    |

#### REMARKS:

1. Emission level (dBuV/m) = Raw Value (dBuV) + Correction Factor (dB/m).
2. Correction Factor (dB/m) = Antenna Factor (dB/m) + Cable Factor (dB).
3. The other emission levels were very low against the limit.
4. Margin value = Emission level – Limit value.



A D T

**ABOVE 1GHz DATA**

**802.11b**

|                        |              |                          |              |
|------------------------|--------------|--------------------------|--------------|
| <b>CHANNEL</b>         | TX Channel 1 | <b>DETECTOR FUNCTION</b> | Peak (PK)    |
| <b>FREQUENCY RANGE</b> | 1GHz ~ 25GHz |                          | Average (AV) |

**ANTENNA POLARITY & TEST DISTANCE: HORIZONTAL AT 3 M**

| NO. | FREQ. (MHz) | EMISSION LEVEL (dBuV/m) | LIMIT (dBuV/m) | MARGIN (dB) | ANTENNA HEIGHT (m) | TABLE ANGLE (Degree) | RAW VALUE (dBuV) | CORRECTION FACTOR (dB/m) |
|-----|-------------|-------------------------|----------------|-------------|--------------------|----------------------|------------------|--------------------------|
| 1   | 2390.00     | 64.3 PK                 | 74.0           | -9.7        | 1.00 H             | 85                   | 32.32            | 31.98                    |
| 2   | 2390.00     | 53.1 AV                 | 54.0           | -0.9        | 1.00 H             | 85                   | 21.12            | 31.98                    |
| 3   | *2412.00    | 110.1 PK                |                |             | 1.00 H             | 85                   | 78.05            | 32.05                    |
| 4   | *2412.00    | 108.3 AV                |                |             | 1.00 H             | 85                   | 76.25            | 32.05                    |
| 5   | 4824.00     | 52.2 PK                 | 74.0           | -21.8       | 1.23 H             | 109                  | 12.62            | 39.58                    |
| 6   | 4824.00     | 43.8 AV                 | 54.0           | -10.2       | 1.23 H             | 109                  | 4.22             | 39.58                    |

**ANTENNA POLARITY & TEST DISTANCE: VERTICAL AT 3 M**

| NO. | FREQ. (MHz) | EMISSION LEVEL (dBuV/m) | LIMIT (dBuV/m) | MARGIN (dB) | ANTENNA HEIGHT (m) | TABLE ANGLE (Degree) | RAW VALUE (dBuV) | CORRECTION FACTOR (dB/m) |
|-----|-------------|-------------------------|----------------|-------------|--------------------|----------------------|------------------|--------------------------|
| 1   | 2390.00     | 61.6 PK                 | 74.0           | -12.4       | 1.28 V             | 37                   | 29.62            | 31.98                    |
| 2   | 2390.00     | 51.1 AV                 | 54.0           | -2.9        | 1.28 V             | 37                   | 19.12            | 31.98                    |
| 3   | *2412.00    | 107.1 PK                |                |             | 1.52 V             | 18                   | 75.05            | 32.05                    |
| 4   | *2412.00    | 105.1 AV                |                |             | 1.52 V             | 18                   | 73.05            | 32.05                    |
| 5   | 4824.00     | 50.9 PK                 | 74.0           | -23.1       | 1.28 V             | 115                  | 11.32            | 39.58                    |
| 6   | 4824.00     | 43.2 AV                 | 54.0           | -10.8       | 1.28 V             | 115                  | 3.62             | 39.58                    |

**REMARKS:**

1. Emission level (dBuV/m) = Raw Value (dBuV) + Correction Factor (dB/m).
2. Correction Factor (dB/m) = Antenna Factor (dB/m) + Cable Factor (dB).
3. The other emission levels were very low against the limit.
4. Margin value = Emission level – Limit value.
5. " \* ": Fundamental frequency.



A D T

|                        |              |                              |              |
|------------------------|--------------|------------------------------|--------------|
| <b>CHANNEL</b>         | TX Channel 6 | <b>DETECTOR<br/>FUNCTION</b> | Peak (PK)    |
| <b>FREQUENCY RANGE</b> | 1GHz ~ 25GHz |                              | Average (AV) |

**ANTENNA POLARITY & TEST DISTANCE: HORIZONTAL AT 3 M**

| NO. | FREQ.<br>(MHz) | EMISSION<br>LEVEL<br>(dBuV/m) | LIMIT<br>(dBuV/m) | MARGIN<br>(dB) | ANTENNA<br>HEIGHT<br>(m) | TABLE<br>ANGLE<br>(Degree) | RAW<br>VALUE<br>(dBuV) | CORRECTION<br>FACTOR<br>(dB/m) |
|-----|----------------|-------------------------------|-------------------|----------------|--------------------------|----------------------------|------------------------|--------------------------------|
| 1   | 2390.00        | 58.5 PK                       | 74.0              | -15.5          | 1.47 H                   | 87                         | 26.52                  | 31.98                          |
| 2   | 2390.00        | 46.9 AV                       | 54.0              | -7.1           | 1.47 H                   | 87                         | 14.92                  | 31.98                          |
| 3   | *2437.00       | 108.0 PK                      |                   |                | 1.47 H                   | 87                         | 75.88                  | 32.12                          |
| 4   | *2437.00       | 106.1 AV                      |                   |                | 1.47 H                   | 87                         | 73.98                  | 32.12                          |
| 5   | 2483.50        | 58.7 PK                       | 74.0              | -15.3          | 1.47 H                   | 87                         | 26.46                  | 32.24                          |
| 6   | 2483.50        | 46.4 AV                       | 54.0              | -7.6           | 1.47 H                   | 87                         | 14.16                  | 32.24                          |
| 7   | 4874.00        | 52.3 PK                       | 74.0              | -21.7          | 1.24 H                   | 112                        | 12.60                  | 39.70                          |
| 8   | 4874.00        | 44.1 AV                       | 54.0              | -9.9           | 1.24 H                   | 112                        | 4.40                   | 39.70                          |
| 9   | 7311.00        | 59.3 PK                       | 74.0              | -14.7          | 1.06 H                   | 38                         | 11.71                  | 47.59                          |
| 10  | 7311.00        | 52.7 AV                       | 54.0              | -1.3           | 1.06 H                   | 38                         | 5.11                   | 47.59                          |

**ANTENNA POLARITY & TEST DISTANCE: VERTICAL AT 3 M**

| NO. | FREQ.<br>(MHz) | EMISSION<br>LEVEL<br>(dBuV/m) | LIMIT<br>(dBuV/m) | MARGIN<br>(dB) | ANTENNA<br>HEIGHT<br>(m) | TABLE<br>ANGLE<br>(Degree) | RAW<br>VALUE<br>(dBuV) | CORRECTION<br>FACTOR<br>(dB/m) |
|-----|----------------|-------------------------------|-------------------|----------------|--------------------------|----------------------------|------------------------|--------------------------------|
| 1   | 2390.00        | 57.8 PK                       | 74.0              | -16.2          | 1.30 V                   | 32                         | 25.82                  | 31.98                          |
| 2   | 2390.00        | 46.6 AV                       | 54.0              | -7.4           | 1.30 V                   | 32                         | 14.62                  | 31.98                          |
| 3   | *2437.00       | 106.1 PK                      |                   |                | 1.30 V                   | 32                         | 73.98                  | 32.12                          |
| 4   | *2437.00       | 104.0 AV                      |                   |                | 1.30 V                   | 32                         | 71.88                  | 32.12                          |
| 5   | 2483.50        | 57.9 PK                       | 74.0              | -16.1          | 1.30 V                   | 32                         | 25.66                  | 32.24                          |
| 6   | 2483.50        | 46.4 AV                       | 54.0              | -7.6           | 1.30 V                   | 32                         | 14.16                  | 32.24                          |
| 7   | 4874.00        | 51.5 PK                       | 74.0              | -22.5          | 1.33 V                   | 106                        | 11.80                  | 39.70                          |
| 8   | 4874.00        | 43.6 AV                       | 54.0              | -10.4          | 1.33 V                   | 106                        | 3.90                   | 39.70                          |
| 9   | 7311.00        | 56.8 PK                       | 74.0              | -17.2          | 1.23 V                   | 222                        | 9.21                   | 47.59                          |
| 10  | 7311.00        | 50.2 AV                       | 54.0              | -3.8           | 1.23 V                   | 222                        | 2.61                   | 47.59                          |

**REMARKS:**

1. Emission level (dBuV/m) = Raw Value (dBuV) + Correction Factor (dB/m).
2. Correction Factor (dB/m) = Antenna Factor (dB/m) + Cable Factor (dB).
3. The other emission levels were very low against the limit.
4. Margin value = Emission level – Limit value.
5. " \* ": Fundamental frequency.





A D T

|                        |               |                          |              |
|------------------------|---------------|--------------------------|--------------|
| <b>CHANNEL</b>         | TX Channel 11 | <b>DETECTOR FUNCTION</b> | Peak (PK)    |
| <b>FREQUENCY RANGE</b> | 1GHz ~ 25GHz  |                          | Average (AV) |

**ANTENNA POLARITY & TEST DISTANCE: HORIZONTAL AT 3 M**

| NO. | FREQ. (MHz)    | EMISSION LEVEL (dBuV/m) | LIMIT (dBuV/m) | MARGIN (dB) | ANTENNA HEIGHT (m) | TABLE ANGLE (Degree) | RAW VALUE (dBuV) | CORRECTION FACTOR (dB/m) |
|-----|----------------|-------------------------|----------------|-------------|--------------------|----------------------|------------------|--------------------------|
| 1   | *2462.00       | 109.1 PK                |                |             | 1.43 H             | 57                   | 76.92            | 32.18                    |
| 2   | *2462.00       | 107.0 AV                |                |             | 1.43 H             | 57                   | 74.82            | 32.18                    |
| 3   | 2483.50        | 61.2 PK                 | 74.0           | -12.8       | 1.43 H             | 57                   | 28.96            | 32.24                    |
| 4   | 2483.50        | 49.1 AV                 | 54.0           | -4.9        | 1.43 H             | 57                   | 16.86            | 32.24                    |
| 5   | 4924.00        | 52.3 PK                 | 74.0           | -21.7       | 1.24 H             | 112                  | 12.46            | 39.84                    |
| 6   | 4924.00        | 44.1 AV                 | 54.0           | -9.9        | 1.24 H             | 112                  | 4.26             | 39.84                    |
| 7   | 7386.00        | 58.8 PK                 | 74.0           | -15.2       | 1.30 H             | 166                  | 11.28            | 47.52                    |
| 8   | <b>7386.00</b> | <b>53.5 AV</b>          | <b>54.0</b>    | <b>-0.5</b> | <b>1.30 H</b>      | <b>166</b>           | <b>5.98</b>      | <b>47.52</b>             |

**ANTENNA POLARITY & TEST DISTANCE: VERTICAL AT 3 M**

| NO. | FREQ. (MHz) | EMISSION LEVEL (dBuV/m) | LIMIT (dBuV/m) | MARGIN (dB) | ANTENNA HEIGHT (m) | TABLE ANGLE (Degree) | RAW VALUE (dBuV) | CORRECTION FACTOR (dB/m) |
|-----|-------------|-------------------------|----------------|-------------|--------------------|----------------------|------------------|--------------------------|
| 1   | *2462.00    | 105.9 PK                |                |             | 1.30 V             | 28                   | 73.72            | 32.18                    |
| 2   | *2462.00    | 104.0 AV                |                |             | 1.30 V             | 28                   | 71.82            | 32.18                    |
| 3   | 2483.50     | 58.2 PK                 | 74.0           | -15.8       | 1.30 V             | 28                   | 25.96            | 32.24                    |
| 4   | 2483.50     | 47.0 AV                 | 54.0           | -7.0        | 1.30 V             | 28                   | 14.76            | 32.24                    |
| 5   | 4924.00     | 51.7 PK                 | 74.0           | -22.3       | 1.28 V             | 101                  | 11.86            | 39.84                    |
| 6   | 4924.00     | 43.7 AV                 | 54.0           | -10.3       | 1.28 V             | 101                  | 3.86             | 39.84                    |
| 7   | 7386.00     | 57.1 PK                 | 74.0           | -16.9       | 1.12 V             | 278                  | 9.58             | 47.52                    |
| 8   | 7386.00     | 51.2 AV                 | 54.0           | -2.8        | 1.12 V             | 278                  | 3.68             | 47.52                    |

**REMARKS:**

1. Emission level (dBuV/m) = Raw Value (dBuV) + Correction Factor (dB/m).
2. Correction Factor (dB/m) = Antenna Factor (dB/m) + Cable Factor (dB).
3. The other emission levels were very low against the limit.
4. Margin value = Emission level – Limit value.
5. " \* " : Fundamental frequency.

**802.11g**

|                        |              |                              |              |
|------------------------|--------------|------------------------------|--------------|
| <b>CHANNEL</b>         | TX Channel 1 | <b>DETECTOR<br/>FUNCTION</b> | Peak (PK)    |
| <b>FREQUENCY RANGE</b> | 1GHz ~ 25GHz |                              | Average (AV) |

| <b>ANTENNA POLARITY &amp; TEST DISTANCE: HORIZONTAL AT 3 M</b> |                        |                                        |                           |                        |                                   |                                     |                                 |                                         |
|----------------------------------------------------------------|------------------------|----------------------------------------|---------------------------|------------------------|-----------------------------------|-------------------------------------|---------------------------------|-----------------------------------------|
| <b>NO.</b>                                                     | <b>FREQ.<br/>(MHz)</b> | <b>EMISSION<br/>LEVEL<br/>(dBuV/m)</b> | <b>LIMIT<br/>(dBuV/m)</b> | <b>MARGIN<br/>(dB)</b> | <b>ANTENNA<br/>HEIGHT<br/>(m)</b> | <b>TABLE<br/>ANGLE<br/>(Degree)</b> | <b>RAW<br/>VALUE<br/>(dBuV)</b> | <b>CORRECTION<br/>FACTOR<br/>(dB/m)</b> |
| 1                                                              | 2390.00                | 68.4 PK                                | 74.0                      | -5.6                   | 1.00 H                            | 263                                 | 36.42                           | 31.98                                   |
| 2                                                              | 2390.00                | 53.1 AV                                | 54.0                      | -0.9                   | 1.00 H                            | 263                                 | 21.12                           | 31.98                                   |
| 3                                                              | *2412.00               | 106.2 PK                               |                           |                        | 1.00 H                            | 263                                 | 74.15                           | 32.05                                   |
| 4                                                              | *2412.00               | 98.4 AV                                |                           |                        | 1.00 H                            | 263                                 | 66.35                           | 32.05                                   |
| 5                                                              | 4824.00                | 54.4 PK                                | 74.0                      | -19.6                  | 1.12 H                            | 91                                  | 14.82                           | 39.58                                   |
| 6                                                              | 4824.00                | 46.7 AV                                | 54.0                      | -7.3                   | 1.12 H                            | 91                                  | 7.12                            | 39.58                                   |
| <b>ANTENNA POLARITY &amp; TEST DISTANCE: VERTICAL AT 3 M</b>   |                        |                                        |                           |                        |                                   |                                     |                                 |                                         |
| <b>NO.</b>                                                     | <b>FREQ.<br/>(MHz)</b> | <b>EMISSION<br/>LEVEL<br/>(dBuV/m)</b> | <b>LIMIT<br/>(dBuV/m)</b> | <b>MARGIN<br/>(dB)</b> | <b>ANTENNA<br/>HEIGHT<br/>(m)</b> | <b>TABLE<br/>ANGLE<br/>(Degree)</b> | <b>RAW<br/>VALUE<br/>(dBuV)</b> | <b>CORRECTION<br/>FACTOR<br/>(dB/m)</b> |
| 1                                                              | 2390.00                | 65.4 PK                                | 74.0                      | -8.6                   | 1.22 V                            | 242                                 | 33.42                           | 31.98                                   |
| 2                                                              | 2390.00                | 50.1 AV                                | 54.0                      | -3.9                   | 1.22 V                            | 242                                 | 18.12                           | 31.98                                   |
| 3                                                              | *2412.00               | 103.2 PK                               |                           |                        | 1.22 V                            | 242                                 | 71.15                           | 32.05                                   |
| 4                                                              | *2412.00               | 95.4 AV                                |                           |                        | 1.22 V                            | 242                                 | 63.35                           | 32.05                                   |
| 5                                                              | 4824.00                | 51.4 PK                                | 74.0                      | -22.6                  | 1.31 V                            | 89                                  | 11.82                           | 39.58                                   |
| 6                                                              | 4824.00                | 43.7 AV                                | 54.0                      | -10.3                  | 1.31 V                            | 89                                  | 4.12                            | 39.58                                   |

**REMARKS:**

1. Emission level (dBuV/m) = Raw Value (dBuV) + Correction Factor (dB/m).
2. Correction Factor (dB/m) = Antenna Factor (dB/m) + Cable Factor (dB).
3. The other emission levels were very low against the limit.
4. Margin value = Emission level – Limit value.
5. " \* ": Fundamental frequency.



A D T

|                        |              |                              |              |
|------------------------|--------------|------------------------------|--------------|
| <b>CHANNEL</b>         | TX Channel 6 | <b>DETECTOR<br/>FUNCTION</b> | Peak (PK)    |
| <b>FREQUENCY RANGE</b> | 1GHz ~ 25GHz |                              | Average (AV) |

**ANTENNA POLARITY & TEST DISTANCE: HORIZONTAL AT 3 M**

| NO. | FREQ.<br>(MHz) | EMISSION<br>LEVEL<br>(dBuV/m) | LIMIT<br>(dBuV/m) | MARGIN<br>(dB) | ANTENNA<br>HEIGHT<br>(m) | TABLE<br>ANGLE<br>(Degree) | RAW<br>VALUE<br>(dBuV) | CORRECTION<br>FACTOR<br>(dB/m) |
|-----|----------------|-------------------------------|-------------------|----------------|--------------------------|----------------------------|------------------------|--------------------------------|
| 1   | 2390.00        | 63.9 PK                       | 74.0              | -10.1          | 1.00 H                   | 277                        | 31.92                  | 31.98                          |
| 2   | 2390.00        | 50.8 AV                       | 54.0              | -3.2           | 1.00 H                   | 277                        | 18.82                  | 31.98                          |
| 3   | *2437.00       | 112.7 PK                      |                   |                | 1.00 H                   | 277                        | 80.58                  | 32.12                          |
| 4   | *2437.00       | 104.9 AV                      |                   |                | 1.00 H                   | 277                        | 72.78                  | 32.12                          |
| 5   | 2483.50        | 61.9 PK                       | 74.0              | -12.1          | 1.00 H                   | 276                        | 29.66                  | 32.24                          |
| 6   | 2483.50        | 48.4 AV                       | 54.0              | -5.6           | 1.00 H                   | 276                        | 16.16                  | 32.24                          |
| 7   | 4874.00        | 55.0 PK                       | 74.0              | -19.0          | 1.12 H                   | 80                         | 15.30                  | 39.70                          |
| 8   | 4874.00        | 47.0 AV                       | 54.0              | -7.0           | 1.12 H                   | 80                         | 7.30                   | 39.70                          |
| 9   | 7311.00        | 64.7 PK                       | 74.0              | -9.3           | 1.16 H                   | 171                        | 17.11                  | 47.59                          |
| 10  | 7311.00        | 53.3 AV                       | 54.0              | -0.7           | 1.16 H                   | 171                        | 5.71                   | 47.59                          |

**ANTENNA POLARITY & TEST DISTANCE: VERTICAL AT 3 M**

| NO. | FREQ.<br>(MHz) | EMISSION<br>LEVEL<br>(dBuV/m) | LIMIT<br>(dBuV/m) | MARGIN<br>(dB) | ANTENNA<br>HEIGHT<br>(m) | TABLE<br>ANGLE<br>(Degree) | RAW<br>VALUE<br>(dBuV) | CORRECTION<br>FACTOR<br>(dB/m) |
|-----|----------------|-------------------------------|-------------------|----------------|--------------------------|----------------------------|------------------------|--------------------------------|
| 1   | 2390.00        | 60.9 PK                       | 74.0              | -13.1          | 1.53 V                   | 330                        | 28.92                  | 31.98                          |
| 2   | 2390.00        | 47.8 AV                       | 54.0              | -6.2           | 1.53 V                   | 330                        | 15.82                  | 31.98                          |
| 3   | *2437.00       | 109.7 PK                      |                   |                | 1.51 V                   | 311                        | 77.58                  | 32.12                          |
| 4   | *2437.00       | 101.9 AV                      |                   |                | 1.51 V                   | 311                        | 69.78                  | 32.12                          |
| 5   | 2483.50        | 58.9 PK                       | 74.0              | -15.1          | 1.49 V                   | 327                        | 26.66                  | 32.24                          |
| 6   | 2483.50        | 45.4 AV                       | 54.0              | -8.6           | 1.49 V                   | 327                        | 13.16                  | 32.24                          |
| 7   | 4874.00        | 52.0 PK                       | 74.0              | -22.0          | 1.28 V                   | 107                        | 12.30                  | 39.70                          |
| 8   | 4874.00        | 44.0 AV                       | 54.0              | -10.0          | 1.28 V                   | 107                        | 4.30                   | 39.70                          |
| 9   | 7311.00        | 61.8 PK                       | 74.0              | -12.2          | 1.24 V                   | 211                        | 14.21                  | 47.59                          |
| 10  | 7311.00        | 51.2 AV                       | 54.0              | -2.8           | 1.24 V                   | 211                        | 3.61                   | 47.59                          |

**REMARKS:**

1. Emission level (dBuV/m) = Raw Value (dBuV) + Correction Factor (dB/m).
2. Correction Factor (dB/m) = Antenna Factor (dB/m) + Cable Factor (dB).
3. The other emission levels were very low against the limit.
4. Margin value = Emission level – Limit value.
5. " \* ": Fundamental frequency.



A D T

|                        |               |                          |              |
|------------------------|---------------|--------------------------|--------------|
| <b>CHANNEL</b>         | TX Channel 11 | <b>DETECTOR FUNCTION</b> | Peak (PK)    |
| <b>FREQUENCY RANGE</b> | 1GHz ~ 25GHz  |                          | Average (AV) |

**ANTENNA POLARITY & TEST DISTANCE: HORIZONTAL AT 3 M**

| NO. | FREQ. (MHz) | EMISSION LEVEL (dBuV/m) | LIMIT (dBuV/m) | MARGIN (dB) | ANTENNA HEIGHT (m) | TABLE ANGLE (Degree) | RAW VALUE (dBuV) | CORRECTION FACTOR (dB/m) |
|-----|-------------|-------------------------|----------------|-------------|--------------------|----------------------|------------------|--------------------------|
| 1   | *2462.00    | 106.3 PK                |                |             | 1.00 H             | 81                   | 74.12            | 32.18                    |
| 2   | *2462.00    | 98.4 AV                 |                |             | 1.00 H             | 81                   | 66.22            | 32.18                    |
| 3   | 2483.50     | 69.3 PK                 | 74.0           | -4.7        | 1.00 H             | 81                   | 37.06            | 32.24                    |
| 4   | 2483.50     | 52.6 AV                 | 54.0           | -1.4        | 1.00 H             | 81                   | 20.36            | 32.24                    |
| 5   | 4924.00     | 54.9 PK                 | 74.0           | -19.1       | 1.09 H             | 89                   | 15.06            | 39.84                    |
| 6   | 4924.00     | 46.8 AV                 | 54.0           | -7.2        | 1.09 H             | 89                   | 6.96             | 39.84                    |
| 7   | 7386.00     | 53.6 PK                 | 74.0           | -20.4       | 1.10 H             | 68                   | 6.08             | 47.52                    |
| 8   | 7386.00     | 46.3 AV                 | 54.0           | -7.7        | 1.10 H             | 68                   | -1.22            | 47.52                    |

**ANTENNA POLARITY & TEST DISTANCE: VERTICAL AT 3 M**

| NO. | FREQ. (MHz) | EMISSION LEVEL (dBuV/m) | LIMIT (dBuV/m) | MARGIN (dB) | ANTENNA HEIGHT (m) | TABLE ANGLE (Degree) | RAW VALUE (dBuV) | CORRECTION FACTOR (dB/m) |
|-----|-------------|-------------------------|----------------|-------------|--------------------|----------------------|------------------|--------------------------|
| 1   | *2462.00    | 103.3 PK                |                |             | 1.44 V             | 306                  | 71.12            | 32.18                    |
| 2   | *2462.00    | 95.4 AV                 |                |             | 1.44 V             | 306                  | 63.22            | 32.18                    |
| 3   | 2483.50     | 66.3 PK                 | 74.0           | -7.7        | 1.50 V             | 317                  | 34.06            | 32.24                    |
| 4   | 2483.50     | 49.6 AV                 | 54.0           | -4.4        | 1.50 V             | 317                  | 17.36            | 32.24                    |
| 5   | 4924.00     | 51.9 PK                 | 74.0           | -22.1       | 1.27 V             | 107                  | 12.06            | 39.84                    |
| 6   | 4924.00     | 43.8 AV                 | 54.0           | -10.2       | 1.27 V             | 107                  | 3.96             | 39.84                    |
| 7   | 7386.00     | 50.6 PK                 | 74.0           | -23.4       | 1.28 V             | 78                   | 3.08             | 47.52                    |
| 8   | 7386.00     | 43.3 AV                 | 54.0           | -10.7       | 1.28 V             | 78                   | -4.22            | 47.52                    |

**REMARKS:**

1. Emission level (dBuV/m) = Raw Value (dBuV) + Correction Factor (dB/m).
2. Correction Factor (dB/m) = Antenna Factor (dB/m) + Cable Factor (dB).
3. The other emission levels were very low against the limit.
4. Margin value = Emission level – Limit value.
5. " \* ": Fundamental frequency.

**802.11n (HT20)**

|                        |              |                              |              |
|------------------------|--------------|------------------------------|--------------|
| <b>CHANNEL</b>         | TX Channel 1 | <b>DETECTOR<br/>FUNCTION</b> | Peak (PK)    |
| <b>FREQUENCY RANGE</b> | 1GHz ~ 25GHz |                              | Average (AV) |

| <b>ANTENNA POLARITY &amp; TEST DISTANCE: HORIZONTAL AT 3 M</b> |                |                               |                   |                |                          |                            |                        |                                |
|----------------------------------------------------------------|----------------|-------------------------------|-------------------|----------------|--------------------------|----------------------------|------------------------|--------------------------------|
| NO.                                                            | FREQ.<br>(MHz) | EMISSION<br>LEVEL<br>(dBuV/m) | LIMIT<br>(dBuV/m) | MARGIN<br>(dB) | ANTENNA<br>HEIGHT<br>(m) | TABLE<br>ANGLE<br>(Degree) | RAW<br>VALUE<br>(dBuV) | CORRECTION<br>FACTOR<br>(dB/m) |
| 1                                                              | 2390.00        | 70.6 PK                       | 74.0              | -3.4           | 1.00 H                   | 304                        | 38.62                  | 31.98                          |
| 2                                                              | 2390.00        | 53.2 AV                       | 54.0              | -0.8           | 1.00 H                   | 304                        | 21.22                  | 31.98                          |
| 3                                                              | *2412.00       | 108.1 PK                      |                   |                | 1.00 H                   | 304                        | 76.05                  | 32.05                          |
| 4                                                              | *2412.00       | 98.0 AV                       |                   |                | 1.00 H                   | 304                        | 65.95                  | 32.05                          |
| 5                                                              | 4824.00        | 54.5 PK                       | 74.0              | -19.5          | 1.21 H                   | 69                         | 14.92                  | 39.58                          |
| 6                                                              | 4824.00        | 46.7 AV                       | 54.0              | -7.3           | 1.21 H                   | 69                         | 7.12                   | 39.58                          |
| <b>ANTENNA POLARITY &amp; TEST DISTANCE: VERTICAL AT 3 M</b>   |                |                               |                   |                |                          |                            |                        |                                |
| NO.                                                            | FREQ.<br>(MHz) | EMISSION<br>LEVEL<br>(dBuV/m) | LIMIT<br>(dBuV/m) | MARGIN<br>(dB) | ANTENNA<br>HEIGHT<br>(m) | TABLE<br>ANGLE<br>(Degree) | RAW<br>VALUE<br>(dBuV) | CORRECTION<br>FACTOR<br>(dB/m) |
| 1                                                              | 2390.00        | 67.6 PK                       | 74.0              | -6.4           | 1.08 V                   | 100                        | 35.62                  | 31.98                          |
| 2                                                              | 2390.00        | 50.2 AV                       | 54.0              | -3.8           | 1.08 V                   | 100                        | 18.22                  | 31.98                          |
| 3                                                              | *2412.00       | 105.0 PK                      |                   |                | 1.48 V                   | 317                        | 72.95                  | 32.05                          |
| 4                                                              | *2412.00       | 95.4 AV                       |                   |                | 1.48 V                   | 317                        | 63.35                  | 32.05                          |
| 5                                                              | 4824.00        | 51.5 PK                       | 74.0              | -22.5          | 1.34 V                   | 114                        | 11.92                  | 39.58                          |
| 6                                                              | 4824.00        | 43.7 AV                       | 54.0              | -10.3          | 1.34 V                   | 114                        | 4.12                   | 39.58                          |

**REMARKS:**

1. Emission level (dBuV/m) = Raw Value (dBuV) + Correction Factor (dB/m).
2. Correction Factor (dB/m) = Antenna Factor (dB/m) + Cable Factor (dB).
3. The other emission levels were very low against the limit.
4. Margin value = Emission level – Limit value.
5. " \* ": Fundamental frequency.



A D T

|                        |              |                              |              |
|------------------------|--------------|------------------------------|--------------|
| <b>CHANNEL</b>         | TX Channel 6 | <b>DETECTOR<br/>FUNCTION</b> | Peak (PK)    |
| <b>FREQUENCY RANGE</b> | 1GHz ~ 25GHz |                              | Average (AV) |

**ANTENNA POLARITY & TEST DISTANCE: HORIZONTAL AT 3 M**

| NO. | FREQ.<br>(MHz) | EMISSION<br>LEVEL<br>(dBuV/m) | LIMIT<br>(dBuV/m) | MARGIN<br>(dB) | ANTENNA<br>HEIGHT<br>(m) | TABLE<br>ANGLE<br>(Degree) | RAW<br>VALUE<br>(dBuV) | CORRECTION<br>FACTOR<br>(dB/m) |
|-----|----------------|-------------------------------|-------------------|----------------|--------------------------|----------------------------|------------------------|--------------------------------|
| 1   | 2390.00        | 65.1 PK                       | 74.0              | -8.9           | 1.00 H                   | 305                        | 33.12                  | 31.98                          |
| 2   | 2390.00        | 50.7 AV                       | 54.0              | -3.3           | 1.00 H                   | 305                        | 18.72                  | 31.98                          |
| 3   | *2437.00       | 114.7 PK                      |                   |                | 1.00 H                   | 305                        | 82.58                  | 32.12                          |
| 4   | *2437.00       | 105.6 AV                      |                   |                | 1.00 H                   | 305                        | 73.48                  | 32.12                          |
| 5   | 2483.50        | 65.3 PK                       | 74.0              | -8.7           | 1.00 H                   | 305                        | 33.06                  | 32.24                          |
| 6   | 2483.50        | 49.7 AV                       | 54.0              | -4.3           | 1.00 H                   | 305                        | 17.46                  | 32.24                          |
| 7   | 4874.00        | 55.0 PK                       | 74.0              | -19.0          | 1.09 H                   | 87                         | 15.30                  | 39.70                          |
| 8   | 4874.00        | 47.0 AV                       | 54.0              | -7.0           | 1.09 H                   | 87                         | 7.30                   | 39.70                          |
| 9   | 7311.00        | 53.7 PK                       | 74.0              | -20.3          | 1.16 H                   | 70                         | 6.11                   | 47.59                          |
| 10  | 7311.00        | 46.1 AV                       | 54.0              | -7.9           | 1.16 H                   | 70                         | -1.49                  | 47.59                          |

**ANTENNA POLARITY & TEST DISTANCE: VERTICAL AT 3 M**

| NO. | FREQ.<br>(MHz) | EMISSION<br>LEVEL<br>(dBuV/m) | LIMIT<br>(dBuV/m) | MARGIN<br>(dB) | ANTENNA<br>HEIGHT<br>(m) | TABLE<br>ANGLE<br>(Degree) | RAW<br>VALUE<br>(dBuV) | CORRECTION<br>FACTOR<br>(dB/m) |
|-----|----------------|-------------------------------|-------------------|----------------|--------------------------|----------------------------|------------------------|--------------------------------|
| 1   | 2390.00        | 62.1 PK                       | 74.0              | -11.9          | 1.25 V                   | 71                         | 30.12                  | 31.98                          |
| 2   | 2390.00        | 47.7 AV                       | 54.0              | -6.3           | 1.25 V                   | 71                         | 15.72                  | 31.98                          |
| 3   | *2437.00       | 111.7 PK                      |                   |                | 1.04 V                   | 104                        | 79.58                  | 32.12                          |
| 4   | *2437.00       | 102.6 AV                      |                   |                | 1.04 V                   | 104                        | 70.48                  | 32.12                          |
| 5   | 2483.50        | 62.3 PK                       | 74.0              | -11.7          | 1.16 V                   | 111                        | 30.06                  | 32.24                          |
| 6   | 2483.50        | 46.7 AV                       | 54.0              | -7.3           | 1.16 V                   | 111                        | 14.46                  | 32.24                          |
| 7   | 4874.00        | 52.0 PK                       | 74.0              | -22.0          | 1.22 V                   | 103                        | 12.30                  | 39.70                          |
| 8   | 4874.00        | 44.0 AV                       | 54.0              | -10.0          | 1.22 V                   | 103                        | 4.30                   | 39.70                          |
| 9   | 7311.00        | 50.7 PK                       | 74.0              | -23.3          | 1.16 V                   | 87                         | 3.11                   | 47.59                          |
| 10  | 7311.00        | 43.1 AV                       | 54.0              | -10.9          | 1.16 V                   | 87                         | -4.49                  | 47.59                          |

**REMARKS:**

1. Emission level (dBuV/m) = Raw Value (dBuV) + Correction Factor (dB/m).
2. Correction Factor (dB/m) = Antenna Factor (dB/m) + Cable Factor (dB).
3. The other emission levels were very low against the limit.
4. Margin value = Emission level – Limit value.
5. " \* ": Fundamental frequency.



A D T

|                        |               |                              |              |
|------------------------|---------------|------------------------------|--------------|
| <b>CHANNEL</b>         | TX Channel 11 | <b>DETECTOR<br/>FUNCTION</b> | Peak (PK)    |
| <b>FREQUENCY RANGE</b> | 1GHz ~ 25GHz  |                              | Average (AV) |

**ANTENNA POLARITY & TEST DISTANCE: HORIZONTAL AT 3 M**

| NO. | FREQ.<br>(MHz) | EMISSION<br>LEVEL<br>(dBuV/m) | LIMIT<br>(dBuV/m) | MARGIN<br>(dB) | ANTENNA<br>HEIGHT<br>(m) | TABLE<br>ANGLE<br>(Degree) | RAW<br>VALUE<br>(dBuV) | CORRECTION<br>FACTOR<br>(dB/m) |
|-----|----------------|-------------------------------|-------------------|----------------|--------------------------|----------------------------|------------------------|--------------------------------|
| 1   | *2462.00       | 108.4 PK                      |                   |                | 1.00 H                   | 306                        | 76.22                  | 32.18                          |
| 2   | *2462.00       | 98.5 AV                       |                   |                | 1.00 H                   | 306                        | 66.32                  | 32.18                          |
| 3   | 2483.50        | 68.2 PK                       | 74.0              | -5.8           | 1.00 H                   | 306                        | 35.96                  | 32.24                          |
| 4   | 2483.50        | 53.4 AV                       | 54.0              | -0.6           | 1.00 H                   | 306                        | 21.16                  | 32.24                          |
| 5   | 4924.00        | 53.8 PK                       | 74.0              | -20.2          | 1.33 H                   | 338                        | 13.96                  | 39.84                          |
| 6   | 4924.00        | 41.8 AV                       | 54.0              | -12.2          | 1.33 H                   | 338                        | 1.96                   | 39.84                          |
| 7   | 7386.00        | 54.8 PK                       | 74.0              | -19.2          | 1.00 H                   | 107                        | 7.28                   | 47.52                          |
| 8   | 7386.00        | 44.2 AV                       | 54.0              | -9.8           | 1.00 H                   | 107                        | -3.32                  | 47.52                          |

**ANTENNA POLARITY & TEST DISTANCE: VERTICAL AT 3 M**

| NO. | FREQ.<br>(MHz) | EMISSION<br>LEVEL<br>(dBuV/m) | LIMIT<br>(dBuV/m) | MARGIN<br>(dB) | ANTENNA<br>HEIGHT<br>(m) | TABLE<br>ANGLE<br>(Degree) | RAW<br>VALUE<br>(dBuV) | CORRECTION<br>FACTOR<br>(dB/m) |
|-----|----------------|-------------------------------|-------------------|----------------|--------------------------|----------------------------|------------------------|--------------------------------|
| 1   | *2462.00       | 105.4 PK                      |                   |                | 1.14 V                   | 76                         | 73.22                  | 32.18                          |
| 2   | *2462.00       | 95.5 AV                       |                   |                | 1.14 V                   | 76                         | 63.32                  | 32.18                          |
| 3   | 2483.50        | 65.2 PK                       | 74.0              | -8.8           | 1.08 V                   | 94                         | 32.96                  | 32.24                          |
| 4   | 2483.50        | 50.4 AV                       | 54.0              | -3.6           | 1.08 V                   | 94                         | 18.16                  | 32.24                          |
| 5   | 4924.00        | 56.8 PK                       | 74.0              | -17.2          | 1.00 V                   | 100                        | 16.96                  | 39.84                          |
| 6   | 4924.00        | 44.9 AV                       | 54.0              | -9.1           | 1.00 V                   | 100                        | 5.06                   | 39.84                          |
| 7   | 7386.00        | 54.6 PK                       | 74.0              | -19.4          | 1.00 V                   | 166                        | 7.08                   | 47.52                          |
| 8   | 7386.00        | 44.0 AV                       | 54.0              | -10.0          | 1.00 V                   | 166                        | -3.52                  | 47.52                          |

**REMARKS:**

1. Emission level (dBuV/m) = Raw Value (dBuV) + Correction Factor (dB/m).
2. Correction Factor (dB/m) = Antenna Factor (dB/m) + Cable Factor (dB).
3. The other emission levels were very low against the limit.
4. Margin value = Emission level – Limit value.
5. " \* " : Fundamental frequency.

802.11n (HT40)

|                        |              |                          |              |
|------------------------|--------------|--------------------------|--------------|
| <b>CHANNEL</b>         | TX Channel 3 | <b>DETECTOR FUNCTION</b> | Peak (PK)    |
| <b>FREQUENCY RANGE</b> | 1GHz ~ 25GHz |                          | Average (AV) |

| ANTENNA POLARITY & TEST DISTANCE: HORIZONTAL AT 3 M |             |                         |                |             |                    |                      |                  |                          |
|-----------------------------------------------------|-------------|-------------------------|----------------|-------------|--------------------|----------------------|------------------|--------------------------|
| NO.                                                 | FREQ. (MHz) | EMISSION LEVEL (dBuV/m) | LIMIT (dBuV/m) | MARGIN (dB) | ANTENNA HEIGHT (m) | TABLE ANGLE (Degree) | RAW VALUE (dBuV) | CORRECTION FACTOR (dB/m) |
| 1                                                   | 2390.00     | 68.5 PK                 | 74.0           | -5.5        | 1.00 H             | 306                  | 36.52            | 31.98                    |
| 2                                                   | 2390.00     | 53.2 AV                 | 54.0           | -0.8        | 1.00 H             | 306                  | 21.22            | 31.98                    |
| 3                                                   | *2422.00    | 103.0 PK                |                |             | 1.00 H             | 306                  | 70.92            | 32.08                    |
| 4                                                   | *2422.00    | 93.2 AV                 |                |             | 1.00 H             | 306                  | 61.12            | 32.08                    |
| 5                                                   | 4844.00     | 54.5 PK                 | 74.0           | -19.5       | 1.24 H             | 113                  | 14.87            | 39.63                    |
| 6                                                   | 4844.00     | 46.5 AV                 | 54.0           | -7.5        | 1.24 H             | 113                  | 6.87             | 39.63                    |
| 7                                                   | 7266.00     | 53.7 PK                 | 74.0           | -20.3       | 1.26 H             | 126                  | 6.10             | 47.60                    |
| 8                                                   | 7266.00     | 46.4 AV                 | 54.0           | -7.6        | 1.26 H             | 126                  | -1.20            | 47.60                    |
| ANTENNA POLARITY & TEST DISTANCE: VERTICAL AT 3 M   |             |                         |                |             |                    |                      |                  |                          |
| NO.                                                 | FREQ. (MHz) | EMISSION LEVEL (dBuV/m) | LIMIT (dBuV/m) | MARGIN (dB) | ANTENNA HEIGHT (m) | TABLE ANGLE (Degree) | RAW VALUE (dBuV) | CORRECTION FACTOR (dB/m) |
| 1                                                   | 2390.00     | 65.5 PK                 | 74.0           | -8.5        | 1.17 V             | 81                   | 33.52            | 31.98                    |
| 2                                                   | 2390.00     | 50.2 AV                 | 54.0           | -3.8        | 1.17 V             | 81                   | 18.22            | 31.98                    |
| 3                                                   | *2422.00    | 100.0 PK                |                |             | 1.10 V             | 77                   | 67.92            | 32.08                    |
| 4                                                   | *2422.00    | 90.2 AV                 |                |             | 1.10 V             | 77                   | 58.12            | 32.08                    |
| 5                                                   | 4844.00     | 51.5 PK                 | 74.0           | -22.5       | 1.26 V             | 109                  | 11.87            | 39.63                    |
| 6                                                   | 4844.00     | 43.5 AV                 | 54.0           | -10.5       | 1.26 V             | 109                  | 3.87             | 39.63                    |
| 7                                                   | 7266.00     | 50.7 PK                 | 74.0           | -23.3       | 1.20 V             | 84                   | 3.10             | 47.60                    |
| 8                                                   | 7266.00     | 43.4 AV                 | 54.0           | -10.6       | 1.20 V             | 84                   | -4.20            | 47.60                    |

**REMARKS:**

1. Emission level (dBuV/m) = Raw Value (dBuV) + Correction Factor (dB/m).
2. Correction Factor (dB/m) = Antenna Factor (dB/m) + Cable Factor (dB).
3. The other emission levels were very low against the limit.
4. Margin value = Emission level – Limit value.
5. " \* ": Fundamental frequency.





A D T

|                        |              |                              |              |
|------------------------|--------------|------------------------------|--------------|
| <b>CHANNEL</b>         | TX Channel 6 | <b>DETECTOR<br/>FUNCTION</b> | Peak (PK)    |
| <b>FREQUENCY RANGE</b> | 1GHz ~ 25GHz |                              | Average (AV) |

**ANTENNA POLARITY & TEST DISTANCE: HORIZONTAL AT 3 M**

| NO. | FREQ.<br>(MHz) | EMISSION<br>LEVEL<br>(dBuV/m) | LIMIT<br>(dBuV/m) | MARGIN<br>(dB) | ANTENNA<br>HEIGHT<br>(m) | TABLE<br>ANGLE<br>(Degree) | RAW<br>VALUE<br>(dBuV) | CORRECTION<br>FACTOR<br>(dB/m) |
|-----|----------------|-------------------------------|-------------------|----------------|--------------------------|----------------------------|------------------------|--------------------------------|
| 1   | 2390.00        | 71.5 PK                       | 74.0              | -2.5           | 1.02 H                   | 262                        | 39.52                  | 31.98                          |
| 2   | <b>2390.00</b> | <b>53.5 AV</b>                | <b>54.0</b>       | <b>-0.5</b>    | <b>1.02 H</b>            | <b>262</b>                 | <b>21.52</b>           | <b>31.98</b>                   |
| 3   | *2437.00       | 104.9 PK                      |                   |                | 1.03 H                   | 264                        | 72.78                  | 32.12                          |
| 4   | *2437.00       | 96.1 AV                       |                   |                | 1.03 H                   | 264                        | 63.98                  | 32.12                          |
| 5   | 2500.00        | 64.7 PK                       | 74.0              | -9.3           | 1.02 H                   | 310                        | 32.42                  | 32.28                          |
| 6   | 2500.00        | 49.2 AV                       | 54.0              | -4.8           | 1.02 H                   | 310                        | 16.92                  | 32.28                          |
| 7   | 4874.00        | 54.0 PK                       | 74.0              | -20.0          | 1.18 H                   | 100                        | 14.30                  | 39.70                          |
| 8   | 4874.00        | 46.4 AV                       | 54.0              | -7.6           | 1.18 H                   | 100                        | 6.70                   | 39.70                          |
| 9   | 7311.00        | 53.4 PK                       | 74.0              | -20.6          | 1.11 H                   | 78                         | 5.81                   | 47.59                          |
| 10  | 7311.00        | 46.3 AV                       | 54.0              | -7.7           | 1.11 H                   | 78                         | -1.29                  | 47.59                          |

**ANTENNA POLARITY & TEST DISTANCE: VERTICAL AT 3 M**

| NO. | FREQ.<br>(MHz) | EMISSION<br>LEVEL<br>(dBuV/m) | LIMIT<br>(dBuV/m) | MARGIN<br>(dB) | ANTENNA<br>HEIGHT<br>(m) | TABLE<br>ANGLE<br>(Degree) | RAW<br>VALUE<br>(dBuV) | CORRECTION<br>FACTOR<br>(dB/m) |
|-----|----------------|-------------------------------|-------------------|----------------|--------------------------|----------------------------|------------------------|--------------------------------|
| 1   | 2390.00        | 68.5 PK                       | 74.0              | -5.5           | 1.23 V                   | 90                         | 36.52                  | 31.98                          |
| 2   | 2390.00        | 50.5 AV                       | 54.0              | -3.5           | 1.23 V                   | 90                         | 18.52                  | 31.98                          |
| 3   | *2437.00       | 101.9 PK                      |                   |                | 1.10 V                   | 99                         | 69.78                  | 32.12                          |
| 4   | *2437.00       | 93.1 AV                       |                   |                | 1.10 V                   | 99                         | 60.98                  | 32.12                          |
| 5   | 2500.00        | 61.7 PK                       | 74.0              | -12.3          | 1.11 V                   | 80                         | 29.42                  | 32.28                          |
| 6   | 2500.00        | 46.2 AV                       | 54.0              | -7.8           | 1.11 V                   | 80                         | 13.92                  | 32.28                          |
| 7   | 4874.00        | 51.0 PK                       | 74.0              | -23.0          | 1.22 V                   | 98                         | 11.30                  | 39.70                          |
| 8   | 4874.00        | 43.4 AV                       | 54.0              | -10.6          | 1.22 V                   | 98                         | 3.70                   | 39.70                          |
| 9   | 7311.00        | 50.4 PK                       | 74.0              | -23.6          | 1.23 V                   | 90                         | 2.81                   | 47.59                          |
| 10  | 7311.00        | 43.3 AV                       | 54.0              | -10.7          | 1.23 V                   | 90                         | -4.29                  | 47.59                          |

**REMARKS:**

1. Emission level (dBuV/m) = Raw Value (dBuV) + Correction Factor (dB/m).
2. Correction Factor (dB/m) = Antenna Factor (dB/m) + Cable Factor (dB).
3. The other emission levels were very low against the limit.
4. Margin value = Emission level – Limit value.
5. " \* ": Fundamental frequency.



A D T

|                        |              |                              |              |
|------------------------|--------------|------------------------------|--------------|
| <b>CHANNEL</b>         | TX Channel 9 | <b>DETECTOR<br/>FUNCTION</b> | Peak (PK)    |
| <b>FREQUENCY RANGE</b> | 1GHz ~ 25GHz |                              | Average (AV) |

**ANTENNA POLARITY & TEST DISTANCE: HORIZONTAL AT 3 M**

| NO. | FREQ.<br>(MHz) | EMISSION<br>LEVEL<br>(dBuV/m) | LIMIT<br>(dBuV/m) | MARGIN<br>(dB) | ANTENNA<br>HEIGHT<br>(m) | TABLE<br>ANGLE<br>(Degree) | RAW<br>VALUE<br>(dBuV) | CORRECTION<br>FACTOR<br>(dB/m) |
|-----|----------------|-------------------------------|-------------------|----------------|--------------------------|----------------------------|------------------------|--------------------------------|
| 1   | *2452.00       | 104.3 PK                      |                   |                | 1.00 H                   | 306                        | 72.14                  | 32.16                          |
| 2   | *2452.00       | 93.9 AV                       |                   |                | 1.00 H                   | 306                        | 61.74                  | 32.16                          |
| 3   | 2483.50        | 67.1 PK                       | 74.0              | -6.9           | 1.00 H                   | 306                        | 34.86                  | 32.24                          |
| 4   | 2483.50        | 53.1 AV                       | 54.0              | -0.9           | 1.00 H                   | 306                        | 20.86                  | 32.24                          |
| 5   | 4904.00        | 54.1 PK                       | 74.0              | -19.9          | 1.16 H                   | 83                         | 14.33                  | 39.77                          |
| 6   | 4904.00        | 46.5 AV                       | 54.0              | -7.5           | 1.16 H                   | 83                         | 6.73                   | 39.77                          |
| 7   | 7356.00        | 53.9 PK                       | 74.0              | -20.1          | 1.21 H                   | 69                         | 6.35                   | 47.55                          |
| 8   | 7356.00        | 46.3 AV                       | 54.0              | -7.7           | 1.21 H                   | 69                         | -1.25                  | 47.55                          |

**ANTENNA POLARITY & TEST DISTANCE: VERTICAL AT 3 M**

| NO. | FREQ.<br>(MHz) | EMISSION<br>LEVEL<br>(dBuV/m) | LIMIT<br>(dBuV/m) | MARGIN<br>(dB) | ANTENNA<br>HEIGHT<br>(m) | TABLE<br>ANGLE<br>(Degree) | RAW<br>VALUE<br>(dBuV) | CORRECTION<br>FACTOR<br>(dB/m) |
|-----|----------------|-------------------------------|-------------------|----------------|--------------------------|----------------------------|------------------------|--------------------------------|
| 1   | *2452.00       | 101.3 PK                      |                   |                | 1.02 V                   | 97                         | 69.14                  | 32.16                          |
| 2   | *2452.00       | 90.9 AV                       |                   |                | 1.02 V                   | 97                         | 58.74                  | 32.16                          |
| 3   | 2483.50        | 64.1 PK                       | 74.0              | -9.9           | 1.11 V                   | 221                        | 31.86                  | 32.24                          |
| 4   | 2483.50        | 50.1 AV                       | 54.0              | -3.9           | 1.11 V                   | 221                        | 17.86                  | 32.24                          |
| 5   | 4904.00        | 51.1 PK                       | 74.0              | -22.9          | 1.29 V                   | 110                        | 11.33                  | 39.77                          |
| 6   | 4904.00        | 43.5 AV                       | 54.0              | -10.5          | 1.29 V                   | 110                        | 3.73                   | 39.77                          |
| 7   | 7356.00        | 50.9 PK                       | 74.0              | -23.1          | 1.14 V                   | 92                         | 3.35                   | 47.55                          |
| 8   | 7356.00        | 43.3 AV                       | 54.0              | -10.7          | 1.14 V                   | 92                         | -4.25                  | 47.55                          |

**REMARKS:**

1. Emission level (dBuV/m) = Raw Value (dBuV) + Correction Factor (dB/m).
2. Correction Factor (dB/m) = Antenna Factor (dB/m) + Cable Factor (dB).
3. The other emission levels were very low against the limit.
4. Margin value = Emission level – Limit value.
5. " \* " : Fundamental frequency.

### 4.3 6dB BANDWIDTH MEASUREMENT

#### 4.3.1 LIMITS OF 6dB BANDWIDTH MEASUREMENT

The minimum of 6dB Bandwidth Measurement is 0.5 MHz.

#### 4.3.2 TEST INSTRUMENTS

| DESCRIPTION & MANUFACTURER | MODEL NO. | SERIAL NO. | CALIBRATED DATE | CALIBRATED UNTIL |
|----------------------------|-----------|------------|-----------------|------------------|
| R&S SPECTRUM ANALYZER      | FSP40     | 100037     | Nov. 01, 2012   | Oct. 31, 2013    |

**Note:**

1. The calibration interval of the above test instruments is 12 months and the calibrations are traceable to NML/ROC and NIST/USA.
2. Tested date : Apr. 11, 2013

#### 4.3.3 TEST PROCEDURE

1. Set resolution bandwidth (RBW) = 100kHz
2. Set the video bandwidth (VBW)  $\geq 3 \times$  RBW, Detector = Peak.
3. Trace mode = max hold.
4. Sweep = auto couple.
5. Measure the maximum width of the emission that is constrained by the frequencies associated with the two amplitude points (upper and lower) that are attenuated by 6 dB relative to the maximum level measured in the fundamental emission

#### 4.3.4 DEVIATION FROM TEST STANDARD

No deviation

#### 4.3.5 TEST SETUP

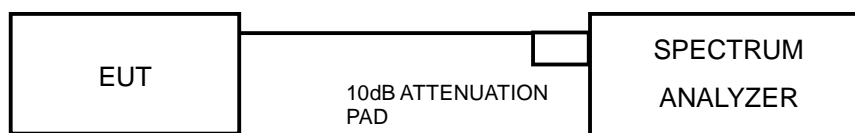

#### 4.3.6 EUT OPERATING CONDITIONS

The software provided by client to enable the EUT under transmission condition continuously at lowest, middle and highest channel frequencies individually.



### 4.3.7 TEST RESULTS

#### 802.11b

| CHANNEL | FREQUENCY (MHz) | 6dB BANDWIDTH (MHz) | MINIMUM LIMIT (MHz) | PASS / FAIL |
|---------|-----------------|---------------------|---------------------|-------------|
| 1       | 2412            | 8.88                | 0.5                 | PASS        |
| 6       | 2437            | 8.86                | 0.5                 | PASS        |
| 11      | 2462            | 9.72                | 0.5                 | PASS        |

#### 802.11g

| CHANNEL | FREQUENCY (MHz) | 6dB BANDWIDTH (MHz) | MINIMUM LIMIT (MHz) | PASS / FAIL |
|---------|-----------------|---------------------|---------------------|-------------|
| 1       | 2412            | 16.42               | 0.5                 | PASS        |
| 6       | 2437            | 16.45               | 0.5                 | PASS        |
| 11      | 2462            | 16.45               | 0.5                 | PASS        |

#### 802.11n (HT20)

| CHANNEL | CHANNEL FREQUENCY (MHz) | 6dB BANDWIDTH (MHz) |         | MINIMUM LIMIT (MHz) | PASS / FAIL |
|---------|-------------------------|---------------------|---------|---------------------|-------------|
|         |                         | CHAIN 0             | CHAIN 1 |                     |             |
| 1       | 2412                    | 17.73               | 17.38   | 0.5                 | PASS        |
| 6       | 2437                    | 17.61               | 17.63   | 0.5                 | PASS        |
| 11      | 2462                    | 17.34               | 17.62   | 0.5                 | PASS        |

#### 802.11n (HT40)

| CHANNEL | CHANNEL FREQUENCY (MHz) | 6dB BANDWIDTH (MHz) |         | MINIMUM LIMIT (MHz) | PASS / FAIL |
|---------|-------------------------|---------------------|---------|---------------------|-------------|
|         |                         | CHAIN 0             | CHAIN 1 |                     |             |
| 3       | 2422                    | 36.46               | 36.08   | 0.5                 | PASS        |
| 6       | 2437                    | 36.25               | 36.11   | 0.5                 | PASS        |
| 9       | 2452                    | 36.55               | 36.06   | 0.5                 | PASS        |

## 4.4 CONDUCTED OUTPUT POWER MEASUREMENT

### 4.4.1 LIMITS OF MAXIMUM PEAK OUTPUT POWER MEASUREMENT

For systems using digital modulation in the 2400–2483.5 MHz band: 1 Watt (30dBm)

Per KDB 662911 D01 Multiple Transmitter Output v01r02 Method of conducted output power measurement on IEEE 802.11 devices,

- Array Gain = 0 dB (i.e., no array gain) for NANT  $\leq$  4;
- Array Gain = 0 dB (i.e., no array gain) for channel widths  $\geq$  40 MHz for any NANT;
- Array Gain =  $5 \log(\text{NANT}/\text{NSS})$  dB or 3 dB, whichever is less for 20-MHz channel widths with NANT  $\geq$  5.

For power measurements on all other devices: Array Gain =  $10 \log(\text{NANT}/\text{NSS})$  dB.

### 4.4.2 INSTRUMENTS

| DESCRIPTION & MANUFACTURER | MODEL NO. | SERIAL NO. | CALIBRATED DATE | CALIBRATED UNTIL |
|----------------------------|-----------|------------|-----------------|------------------|
| Power Meter                | ML2495A   | 0824006    | May 10, 2012    | May 09, 2013     |
| Power Sensor               | MA2411B   | 0738172    | May 10, 2012    | May 09, 2013     |

- Note:**
1. The calibration interval of the above test instruments is 12 months and the calibrations are traceable to NML/ROC and NIST/USA.
  2. Tested date : Apr. 11, 2013

### 4.4.3 TEST PROCEDURES

The peak power sensor was used on the output port of the EUT. A power meter was used to read the response of the peak power sensor. Record the peak power level.

### 4.4.4 DEVIATION FROM TEST STANDARD

No deviation.

### 4.4.5 TEST SETUP

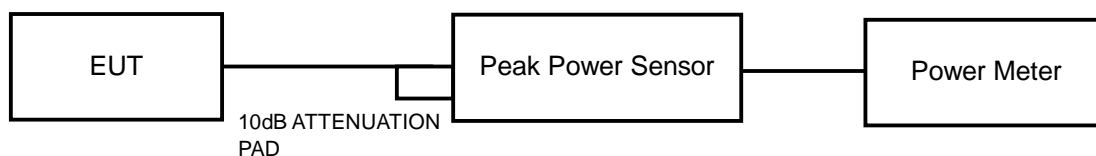

#### 4.4.6 EUT OPERATING CONDITIONS

Same as Item 4.3.6



A D T

#### 4.4.7 TEST RESULTS

##### 802.11b

| CHANNEL | FREQUENCY (MHz) | PEAK POWER (mW) | PEAK POWER (dBm) | LIMIT (dBm) | PASS/FAIL |
|---------|-----------------|-----------------|------------------|-------------|-----------|
| 1       | 2412            | 188.799         | 22.76            | 30          | PASS      |
| 6       | 2437            | 159.956         | 22.04            | 30          | PASS      |
| 11      | 2462            | 134.586         | 21.29            | 30          | PASS      |

##### 802.11g

| CHANNEL | FREQUENCY (MHz) | PEAK POWER (mW) | PEAK POWER (dBm) | LIMIT (dBm) | PASS/FAIL |
|---------|-----------------|-----------------|------------------|-------------|-----------|
| 1       | 2412            | 123.595         | 20.92            | 30          | PASS      |
| 6       | 2437            | 268.534         | 24.29            | 30          | PASS      |
| 11      | 2462            | 154.882         | 21.90            | 30          | PASS      |

##### 802.11n (HT20)

| CHAN. | FREQUENCY (MHz) | PEAK POWER (dBm) |         | TOTAL POWER (mW) | TOTAL POWER (dBm) | LIMIT (dBm) | PASS / FAIL |
|-------|-----------------|------------------|---------|------------------|-------------------|-------------|-------------|
|       |                 | CHAIN 0          | CHAIN 1 |                  |                   |             |             |
| 1     | 2412            | 20.30            | 20.07   | 208.777          | 23.20             | 30          | PASS        |
| 6     | 2437            | 24.17            | 23.32   | 475.999          | 26.78             | 30          | PASS        |
| 11    | 2462            | 21.36            | 20.80   | 256.999          | 24.10             | 30          | PASS        |

##### 802.11n (HT40)

| CHAN. | FREQUENCY (MHz) | PEAK POWER (dBm) |         | TOTAL POWER (mW) | TOTAL POWER (dBm) | LIMIT (dBm) | PASS / FAIL |
|-------|-----------------|------------------|---------|------------------|-------------------|-------------|-------------|
|       |                 | CHAIN 0          | CHAIN 1 |                  |                   |             |             |
| 3     | 2422            | 18.18            | 19.12   | 147.424          | 21.69             | 30          | PASS        |
| 6     | 2437            | 21.30            | 21.45   | 274.533          | 24.39             | 30          | PASS        |
| 9     | 2452            | 19.16            | 20.01   | 182.645          | 22.62             | 30          | PASS        |



A D T

## 4.5 AVERAGE OUTPUT POWER

### 4.5.1 FOR REFERENCE.

### 4.5.2 TEST INSTRUMENTS

| DESCRIPTION & MANUFACTURER | MODEL NO. | SERIAL NO. | CALIBRATED DATE | CALIBRATED UNTIL |
|----------------------------|-----------|------------|-----------------|------------------|
| Power Meter                | ML2495A   | 0824006    | May 10, 2012    | May 09, 2013     |
| Power Sensor               | MA2411B   | 0738172    | May 10, 2012    | May 09, 2013     |

**Note:**

1. The calibration interval of the above test instruments is 12 months and the calibrations are traceable to NML/ROC and NIST/USA.
2. Tested date : Apr. 11, 2013

### 4.5.3 TEST PROCEDURES

The average power sensor was used on the output port of the EUT. A power meter was used to read the response of the power sensor. Record the power level.

### 4.5.4 TEST SETUP

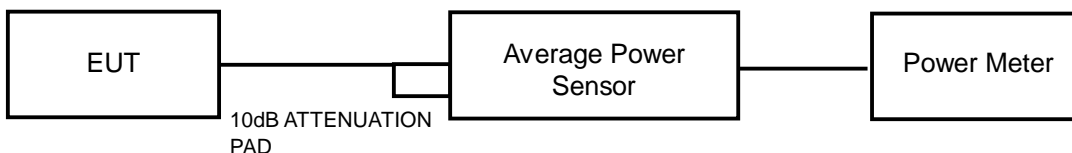

### 4.5.5 EUT OPERATING CONDITIONS

Same as Item 4.3.6





A D T

#### 4.5.6 TEST RESULTS

##### 802.11b

| CHAN. | FREQUENCY (MHz) | AVERAGE POWER (mW) | AVERAGE POWER (dBm) |
|-------|-----------------|--------------------|---------------------|
| 1     | 2412            | 102.565            | 20.11               |
| 6     | 2437            | 80.724             | 19.07               |
| 11    | 2462            | 65.163             | 18.14               |

##### 802.11g

| CHAN. | FREQUENCY (MHz) | AVERAGE POWER (mW) | AVERAGE POWER (dBm) |
|-------|-----------------|--------------------|---------------------|
| 1     | 2412            | 20.845             | 13.19               |
| 6     | 2437            | 114.025            | 20.57               |
| 11    | 2462            | 25.293             | 14.03               |

##### 802.11n (HT20)

| CHAN. | FREQUENCY (MHz) | AVERAGE POWER (dBm) |         | TOTAL POWER (mW) | TOTAL POWER (dBm) |
|-------|-----------------|---------------------|---------|------------------|-------------------|
|       |                 | CHAIN 0             | CHAIN 1 |                  |                   |
| 1     | 2412            | 12.36               | 11.98   | 32.995           | 15.18             |
| 6     | 2437            | 20.64               | 19.45   | 203.983          | 23.10             |
| 11    | 2462            | 13.49               | 13.15   | 42.990           | 16.33             |

##### 802.11n (HT40)

| CHAN. | FREQUENCY (MHz) | AVERAGE POWER (dBm) |         | TOTAL POWER (mW) | TOTAL POWER (dBm) |
|-------|-----------------|---------------------|---------|------------------|-------------------|
|       |                 | CHAIN 0             | CHAIN 1 |                  |                   |
| 3     | 2422            | 9.96                | 10.91   | 22.239           | 13.47             |
| 6     | 2437            | 13.27               | 13.93   | 45.949           | 16.62             |
| 9     | 2452            | 11.34               | 12.34   | 30.754           | 14.88             |

## 4.6 POWER SPECTRAL DENSITY MEASUREMENT

### 4.6.1 LIMITS OF POWER SPECTRAL DENSITY MEASUREMENT

The Maximum of Power Spectral Density Measurement is 8dBm.

### 4.6.2 TEST INSTRUMENTS

| DESCRIPTION & MANUFACTURER | MODEL NO. | SERIAL NO. | CALIBRATED DATE | CALIBRATED UNTIL |
|----------------------------|-----------|------------|-----------------|------------------|
| R&S Spectrum Analyzer      | FSP40     | 100037     | Nov. 01, 2012   | Oct. 31, 2013    |

**Note:**

1. The calibration interval of the above test instruments is 12 months and the calibrations are traceable to NML/ROC and NIST/USA.
2. Tested date : Apr. 11, 2013

### 4.6.3 TEST PROCEDURE

1. Set the RBW = 3 kHz, VBW =10 kHz, Detector = peak.
2. Sweep time = auto couple, Trace mode = max hold, allow trace to fully stabilize.
3. Use the peak marker function to determine the maximum amplitude level.

### 4.6.4 DEVIATION FROM TEST STANDARD

No deviation

### 4.6.5 TEST SETUP

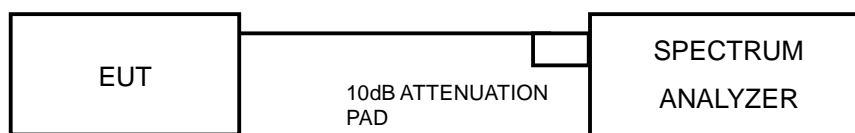

### 4.6.6 EUT OPERATING CONDITION

Same as Item 4.3.6



A D T

#### 4.6.7 TEST RESULTS

##### 802.11b

| Channel | FREQUENCY (MHz) | PSD (dBm/3kHz) | Limit (dBm/3kHz) | PASS /FAIL |
|---------|-----------------|----------------|------------------|------------|
| 1       | 2412            | -2.48          | 8                | PASS       |
| 6       | 2437            | -4.60          | 8                | PASS       |
| 11      | 2462            | -4.39          | 8                | PASS       |

##### 802.11g

| Channel | FREQUENCY (MHz) | PSD (dBm/3kHz) | Limit (dBm/3kHz) | PASS /FAIL |
|---------|-----------------|----------------|------------------|------------|
| 1       | 2412            | -13.16         | 8                | PASS       |
| 6       | 2437            | -4.76          | 8                | PASS       |
| 11      | 2462            | -12.19         | 8                | PASS       |

##### 802.11n (HT20)

| TX chain | Channel | FREQ. (MHz) | PSD (dBm/3kHz) | 10 log (N=2) dB | Total PSD (dBm/3kHz) | Limit (dBm/3kHz) | PASS /FAIL |
|----------|---------|-------------|----------------|-----------------|----------------------|------------------|------------|
| 0        | 1       | 2412        | -12.93         | 3.01            | -9.92                | 8                | PASS       |
|          | 6       | 2437        | -4.53          | 3.01            | -1.52                | 8                | PASS       |
|          | 11      | 2462        | -12.16         | 3.01            | -9.15                | 8                | PASS       |
| 1        | 1       | 2412        | -14.58         | 3.01            | -11.57               | 8                | PASS       |
|          | 6       | 2437        | -7.14          | 3.01            | -4.13                | 8                | PASS       |
|          | 11      | 2462        | -11.94         | 3.01            | -8.93                | 8                | PASS       |

**NOTE:** Directional gain =  $10 \log[(10^{G1/20} + 10^{G2/20})^2 / 2] = 3.6\text{dBi} < 6\text{dBi}$ , so the power density limit shall not be reduced.

##### 802.11n (HT40)

| TX chain | Channel | FREQ. (MHz) | PSD (dBm/3kHz) | 10 log (N=2) dB | Total PSD (dBm/3kHz) | Limit (dBm/3kHz) | PASS /FAIL |
|----------|---------|-------------|----------------|-----------------|----------------------|------------------|------------|
| 0        | 3       | 2422        | -14.42         | 3.01            | -11.41               | 8                | PASS       |
|          | 6       | 2437        | -15.14         | 3.01            | -12.13               | 8                | PASS       |
|          | 9       | 2452        | -13.94         | 3.01            | -10.93               | 8                | PASS       |
| 1        | 3       | 2422        | -17.86         | 3.01            | -14.85               | 8                | PASS       |
|          | 6       | 2437        | -15.44         | 3.01            | -12.43               | 8                | PASS       |
|          | 9       | 2452        | -16.48         | 3.01            | -13.47               | 8                | PASS       |

**NOTE:** Directional gain =  $10 \log[(10^{G1/20} + 10^{G2/20})^2 / 2] = 3.6\text{dBi} < 6\text{dBi}$ , so the power density limit shall not be reduced.



A D T

## 4.7 CONDUCTED OUT-BAND EMISSION MEASUREMENT

### 4.7.1 LIMITS OF CONDUCTED OUT-BAND EMISSION MEASUREMENT

Below 20dB of the highest emission level of operating band (in 100kHz Resolution Bandwidth).

### 4.7.2 TEST INSTRUMENTS

| DESCRIPTION & MANUFACTURER | MODEL NO. | SERIAL NO. | CALIBRATED DATE | CALIBRATED UNTIL |
|----------------------------|-----------|------------|-----------------|------------------|
| R&S Spectrum Analyzer      | FSP40     | 100037     | Nov. 01, 2012   | Oct. 31, 2013    |

**Note:**

1. The calibration interval of the above test instruments is 12 months and the calibrations are traceable to NML/ROC and NIST/USA.
2. Tested date : Apr. 11, 2013

### 4.7.3 TEST PROCEDURE

#### Measurement Procedure - Reference Level

1. Set the RBW = 100 kHz.
2. Set the VBW  $\geq$  300 kHz.
3. Detector = peak.
4. Sweep time = auto couple.
5. Trace mode = max hold.
6. Allow trace to fully stabilize.
7. Use the peak marker function to determine the maximum power level in any 100 kHz band segment within the fundamental EBW.

#### Measurement Procedure –Unwanted Emission Level

1. Set RBW = 100 kHz.
2. Set VBW  $\geq$  300 kHz.
3. Set span to encompass the spectrum to be examined
4. Detector = peak.
5. Trace Mode = max hold.
6. Sweep = auto couple.

#### 4.7.4 DEVIATION FROM TEST STANDARD

No deviation

#### 4.7.5 TEST SETUP

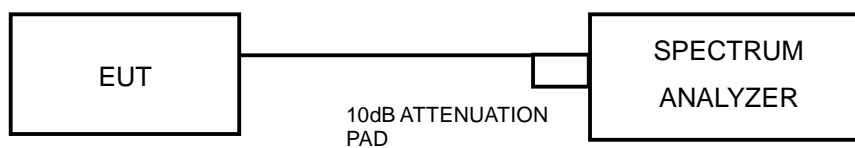

#### 4.7.6 EUT OPERATING CONDITION

Same as Item 4.3.6

#### 4.7.7 TEST RESULTS

The spectrum plots are attached on the following pages. D1 line indicates the highest level, and D2 line indicates the 20dB offset below D1. It shows compliance with the requirement.



A D T

### 802.11b:

#### CH 1

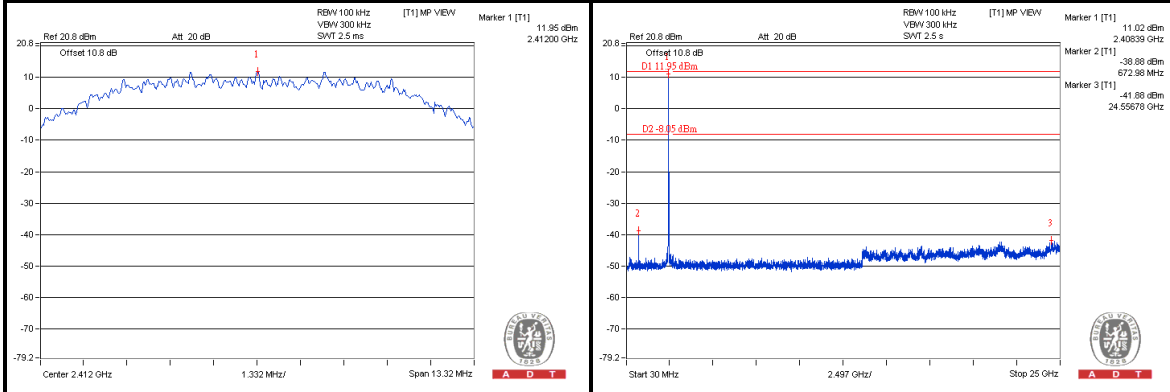

#### CH 6

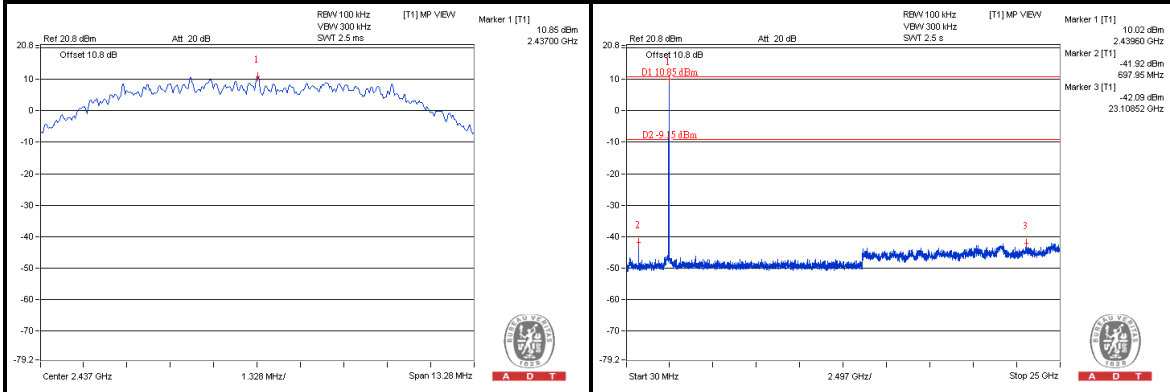

#### CH 11

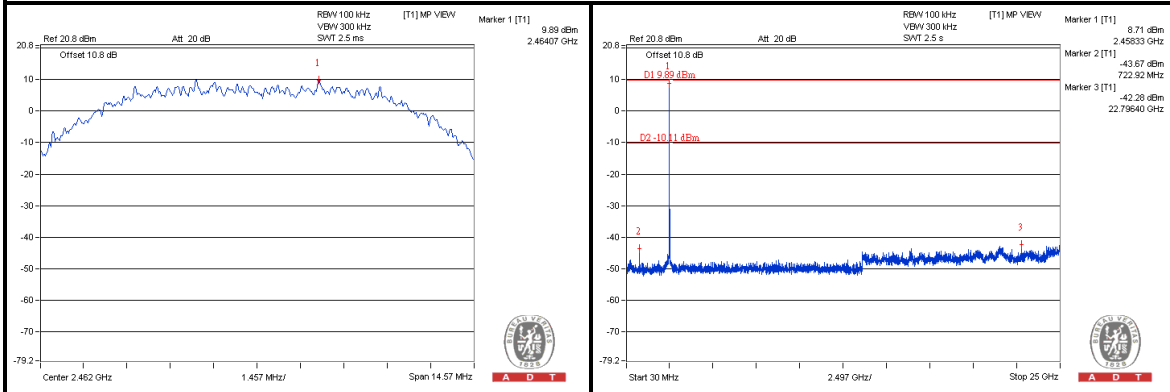



A D T

### 802.11g:

#### CH 1

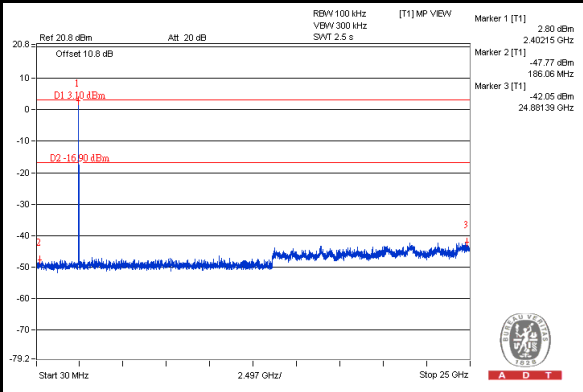
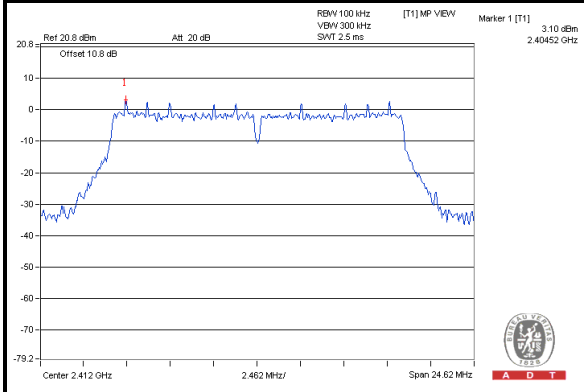

#### CH 6

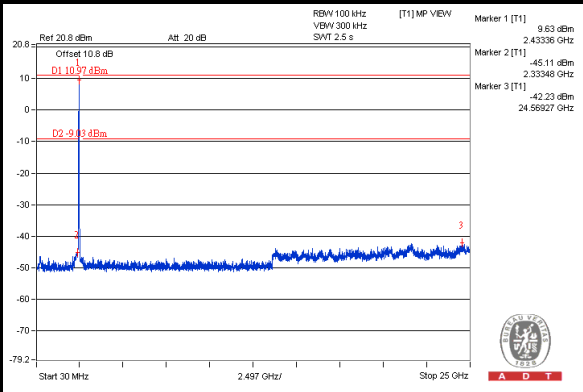
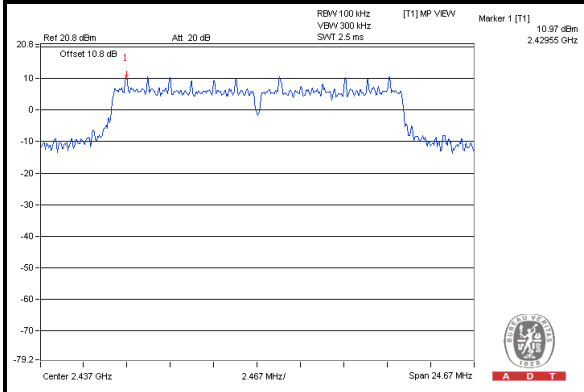

#### CH 11

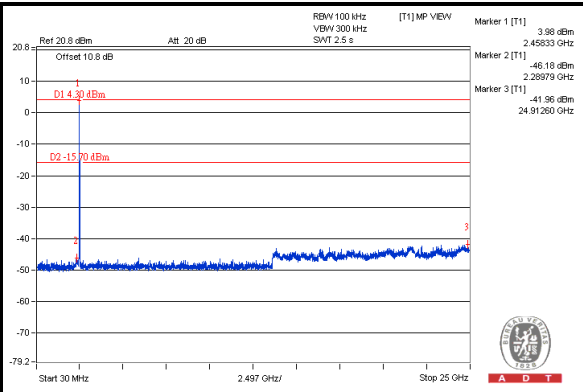
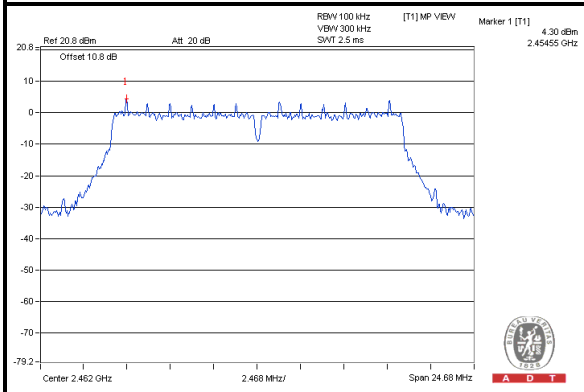



A D T

### 802.11n (HT20):

#### Chain (0)

#### CH 1

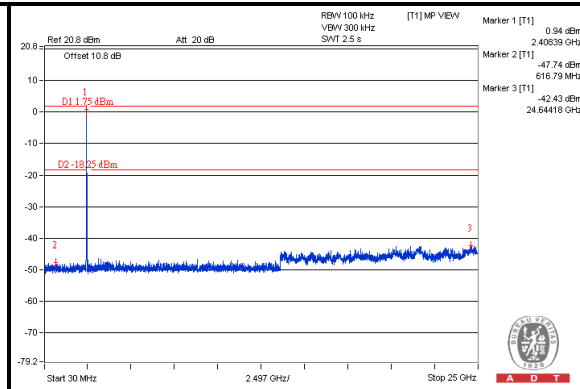
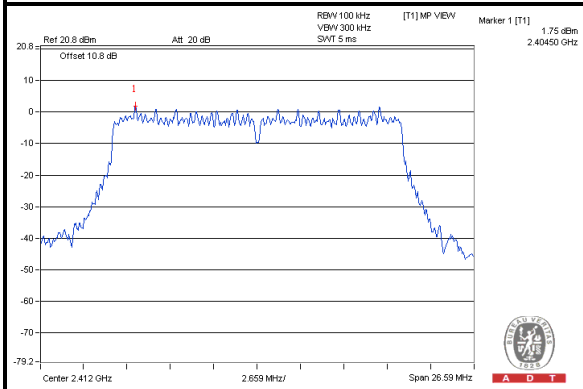

#### CH 6

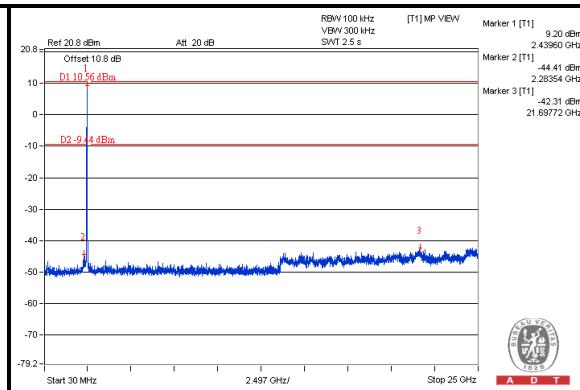
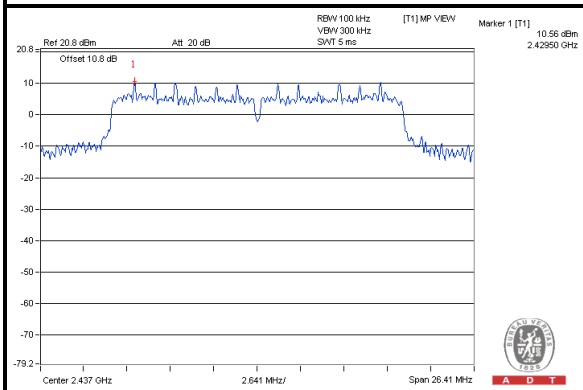

#### CH 11

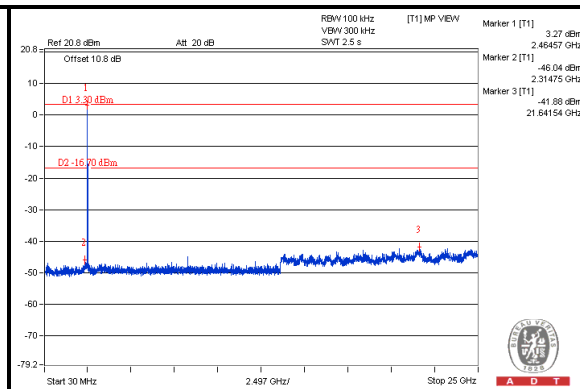
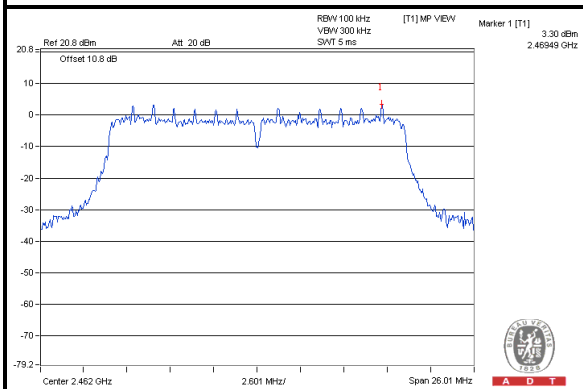





A D T

### Chain (1)

#### CH 1

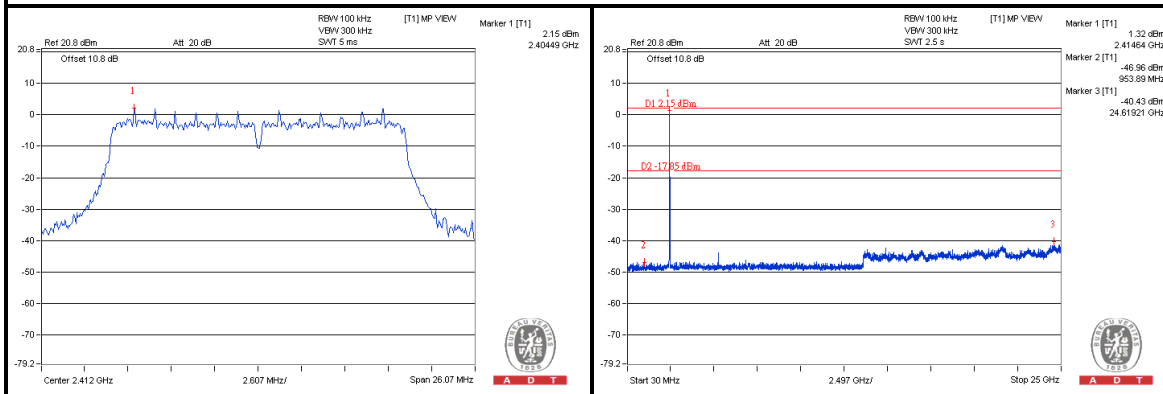

#### CH 6

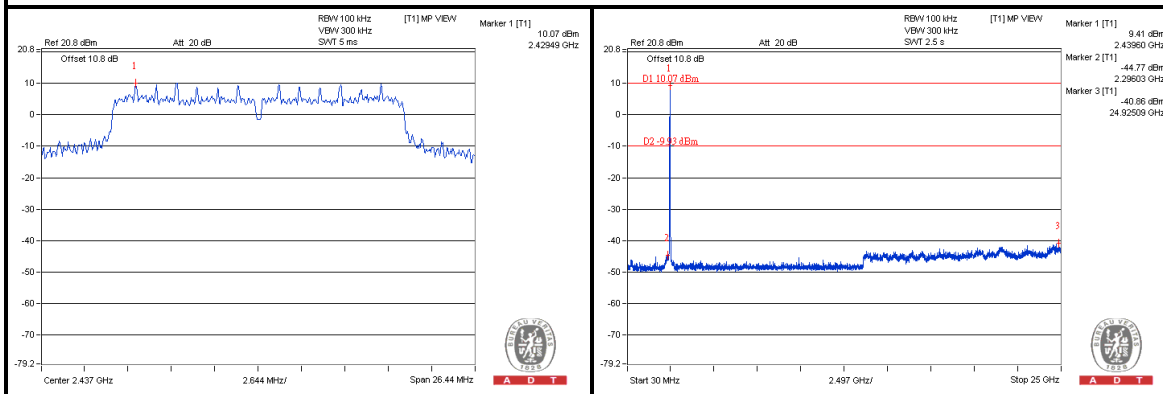

#### CH 11

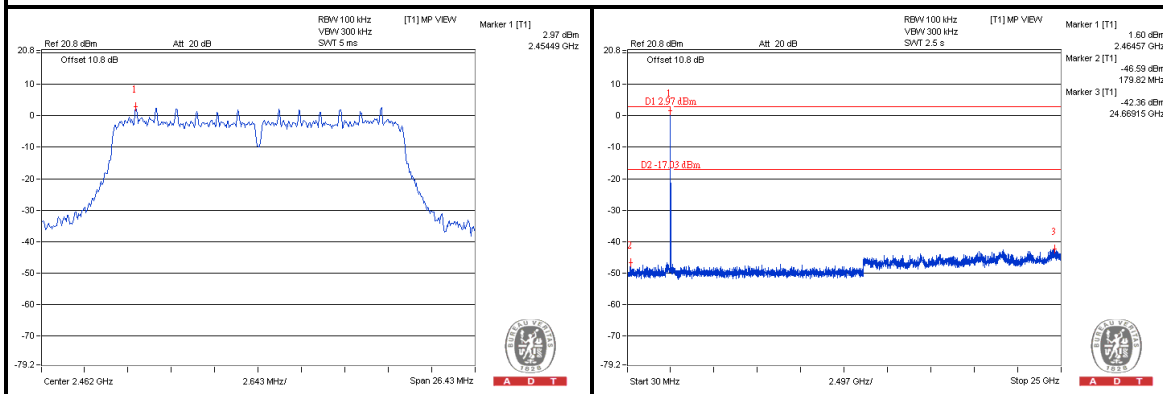



A D T

### 802.11n (HT40):

#### Chain (0)

#### CH 3

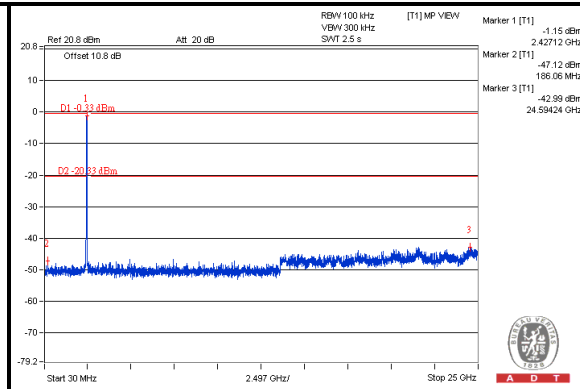
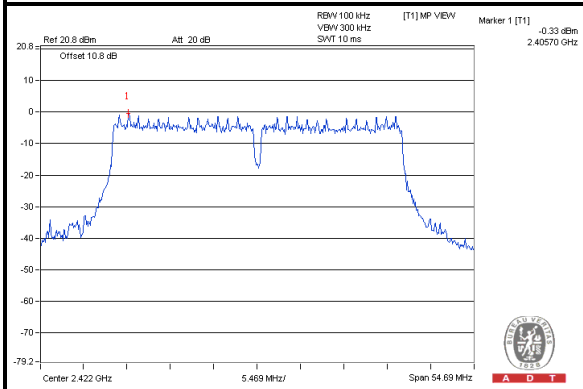

#### CH 6

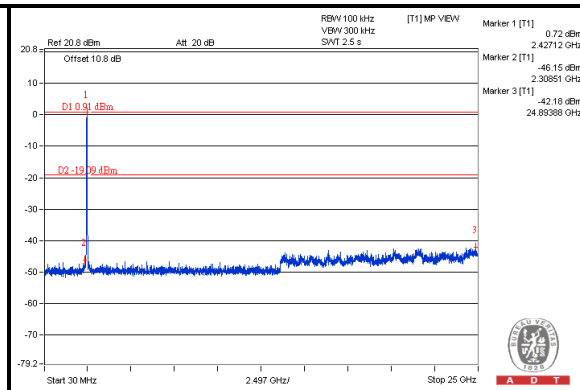
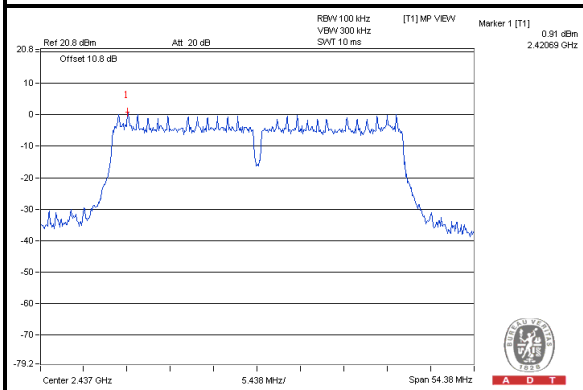

#### CH 9

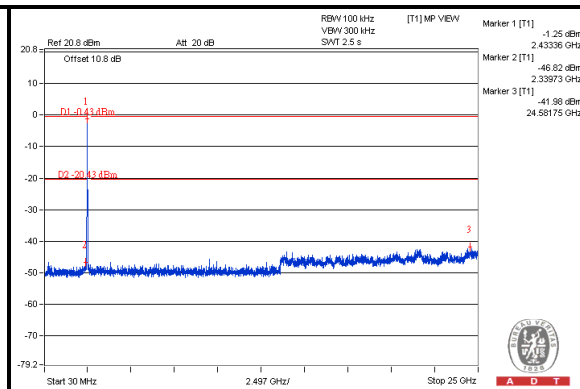
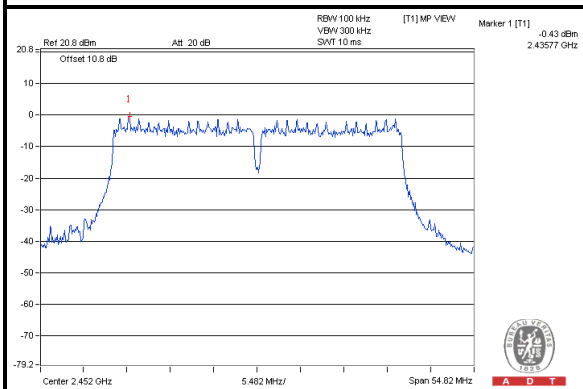



A D T

### Chain (1)

#### CH 3

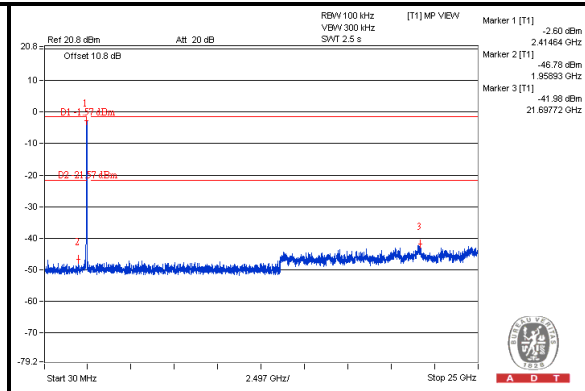
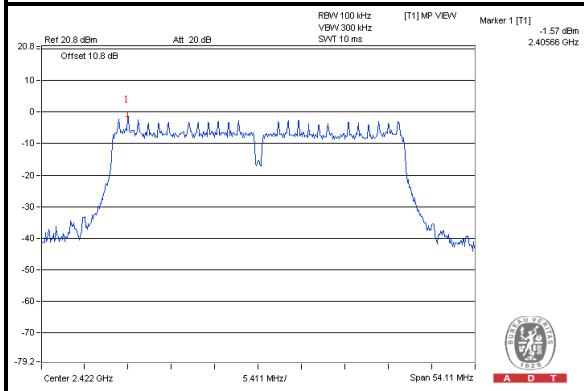

#### CH 6

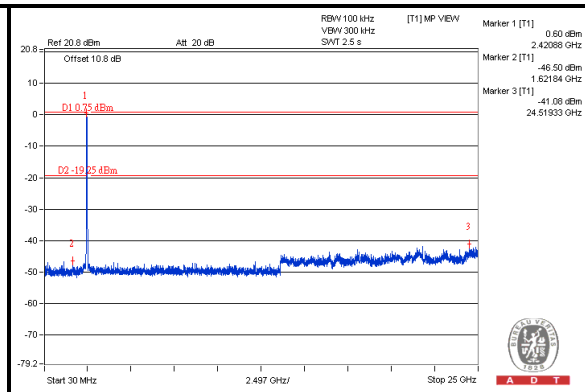
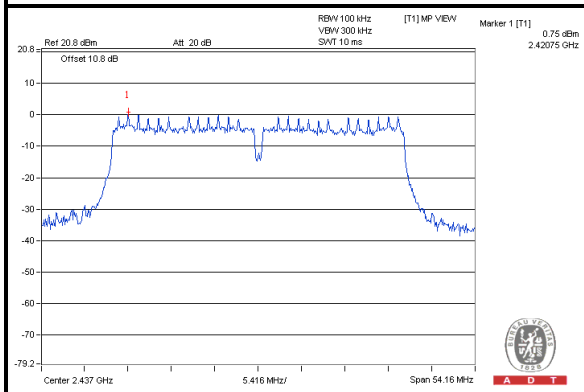

#### CH 9

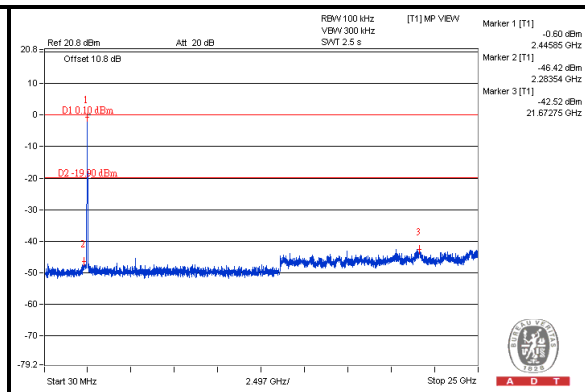
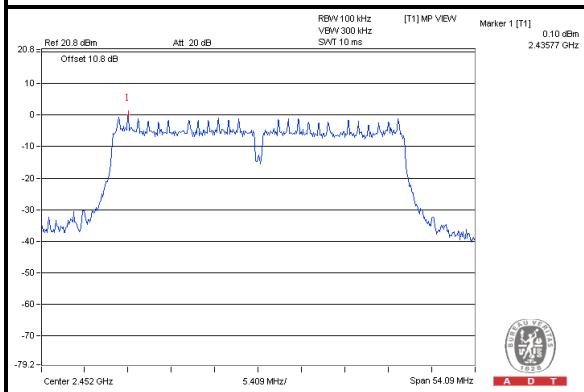



A D T

## 5. TEST TYPES AND RESULTS (FOR 5GHz, 5.725~5.850GHz Band)

### 5.1 CONDUCTED EMISSION MEASUREMENT

#### 5.1.1 LIMITS OF CONDUCTED EMISSION MEASUREMENT

| FREQUENCY OF EMISSION (MHz) | CONDUCTED LIMIT (dB $\mu$ V) |          |
|-----------------------------|------------------------------|----------|
|                             | Quasi-peak                   | Average  |
| 0.15-0.5                    | 66 to 56                     | 56 to 46 |
| 0.5-5                       | 56                           | 46       |
| 5-30                        | 60                           | 50       |

- NOTE:** 1. The lower limit shall apply at the transition frequencies.  
 2. The limit decreases in line with the logarithm of the frequency in the range of 0.15 to 0.50 MHz.

#### 5.1.2 TEST INSTRUMENTS

| DESCRIPTION & MANUFACTURER                                                     | MODEL NO.                   | SERIAL NO. | CALIBRATED DATE | CALIBRATED UNTIL |
|--------------------------------------------------------------------------------|-----------------------------|------------|-----------------|------------------|
| Test Receiver<br>ROHDE & SCHWARZ                                               | ESCS 30                     | 100287     | Feb. 28, 2013   | Feb. 27, 2014    |
| Line-Impedance<br>Stabilization Network<br>(for EUT)<br>SCHWARZBECK            | NSLK 8127                   | 8127-523   | Sep. 19, 2012   | Sep. 20, 2013    |
| Line-Impedance<br>Stabilization Network<br>(for Peripheral)<br>ROHDE & SCHWARZ | ESH3-Z5                     | 848773/004 | Oct. 29, 2012   | Oct. 28, 2013    |
| RF Cable<br>(JYEBAO)                                                           | 5DFB                        | COACAB-002 | Aug. 05, 2012   | Aug. 04, 2013    |
| 50 ohms Terminator                                                             | 50                          | 3          | Oct. 23, 2012   | Oct. 22, 2013    |
| Software<br>ADT                                                                | BV<br>ADT_Cond_V7.3.7<br>.3 | NA         | NA              | NA               |

**Note:**

1. The calibration interval of the above test instruments is 12 months and the calibrations are traceable to NML/ROC and NIST/USA.
2. The test was performed in Shielded Room No. A.
3. The VCCI Con A Registration No. is C-817.
4. Tested Date: Apr. 08, 2013

### 5.1.3 TEST PROCEDURES

- a. The EUT was placed 0.4 meters from the conducting wall of the shielded room with EUT being connected to the power mains through a line impedance stabilization network (LISN). Other support units were connected to the power mains through another LISN.
- b. The two LISNs provide 50 ohm/ 50uH of coupling impedance for the measuring instrument.
- c. Both lines of the power mains connected to the EUT were checked for maximum conducted interference.
- d. The frequency range from 150kHz to 30MHz was searched. Emission levels under (Limit – 20dB) were not recorded.

**NOTE:**

- 1. The resolution bandwidth of test receiver is 9kHz for Quasi-peak detection (QP) & Average detection (AV).

### 5.1.4 DEVIATION FROM TEST STANDARD

No deviation

### 5.1.5 TEST SETUP

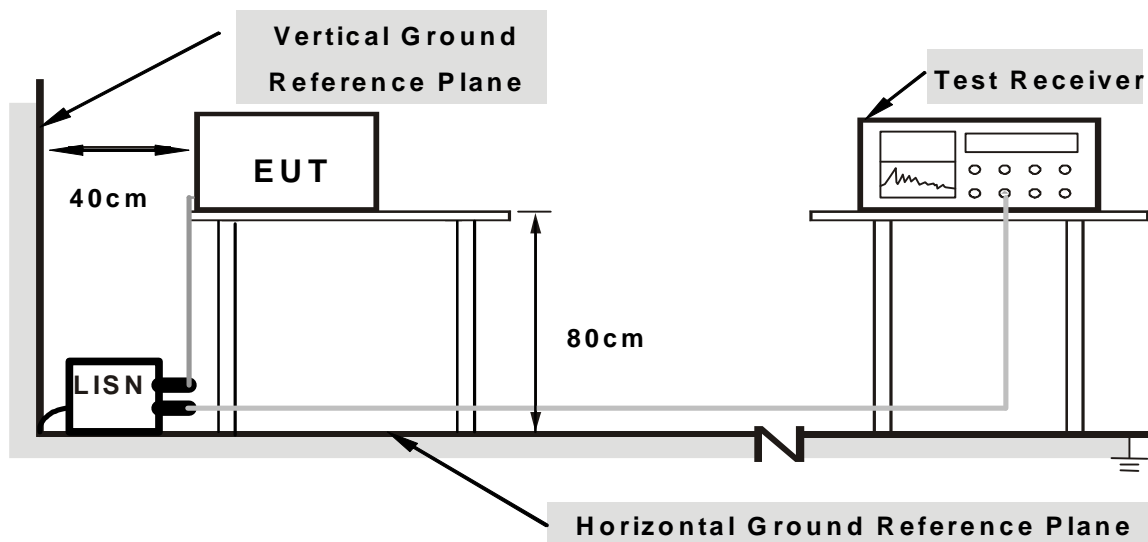

**Note: 1.Support units were connected to second LISN.**

For the actual test configuration, please refer to the related item – Photographs of the Test Configuration.

## 5.1.6 EUT OPERATING CONDITIONS

Same as the 4.1.6

### 5.1.7 TEST RESULTS (MODE 1)

|              |          |                          |                                |
|--------------|----------|--------------------------|--------------------------------|
| <b>PHASE</b> | Line (L) | <b>DETECTOR FUNCTION</b> | Quasi-Peak (QP) / Average (AV) |
|--------------|----------|--------------------------|--------------------------------|

| No       | Freq.<br>[MHz] | Corr.<br>Factor<br>(dB) | Reading Value |              | Emission Level |              | Limit        |              | Margin        |              |
|----------|----------------|-------------------------|---------------|--------------|----------------|--------------|--------------|--------------|---------------|--------------|
|          |                |                         | [dB (uV)]     |              | [dB (uV)]      |              | [dB (uV)]    |              | (dB)          |              |
|          |                |                         | Q.P.          | AV.          | Q.P.           | AV.          | Q.P.         | AV.          | Q.P.          | AV.          |
| 1        | 0.15000        | 0.10                    | 48.42         | 28.39        | 48.52          | 28.49        | 66.00        | 56.00        | -17.48        | -27.51       |
| 2        | 0.20469        | 0.11                    | 47.53         | 30.66        | 47.64          | 30.77        | 63.42        | 53.42        | -15.78        | -22.65       |
| 3        | 0.24375        | 0.12                    | 45.25         | 23.22        | 45.37          | 23.34        | 61.97        | 51.97        | -16.60        | -28.63       |
| 4        | 0.33750        | 0.14                    | 40.50         | 14.71        | 40.64          | 14.85        | 59.26        | 49.26        | -18.62        | -34.41       |
| 5        | 0.40391        | 0.16                    | 37.77         | 14.09        | 37.93          | 14.25        | 57.77        | 47.77        | -19.84        | -33.52       |
| 6        | 0.44297        | 0.16                    | 38.33         | 16.03        | 38.49          | 16.19        | 57.01        | 47.01        | -18.51        | -30.81       |
| 7        | 0.59141        | 0.17                    | 36.63         | 17.26        | 36.80          | 17.43        | 56.00        | 46.00        | -19.20        | -28.57       |
| 8        | 2.54688        | 0.25                    | 37.65         | 25.64        | 37.90          | 25.89        | 56.00        | 46.00        | -18.10        | -20.11       |
| <b>9</b> | <b>4.65625</b> | <b>0.35</b>             | <b>44.24</b>  | <b>39.28</b> | <b>44.59</b>   | <b>39.63</b> | <b>56.00</b> | <b>46.00</b> | <b>-11.41</b> | <b>-6.37</b> |

**REMARKS:**

1. Q.P. and AV. are abbreviations of quasi-peak and average individually.
2. The emission levels of other frequencies were very low against the limit.
3. Margin value = Emission level - Limit value
4. Correction factor = Insertion loss + Cable loss
5. Emission Level = Correction Factor + Reading Value.

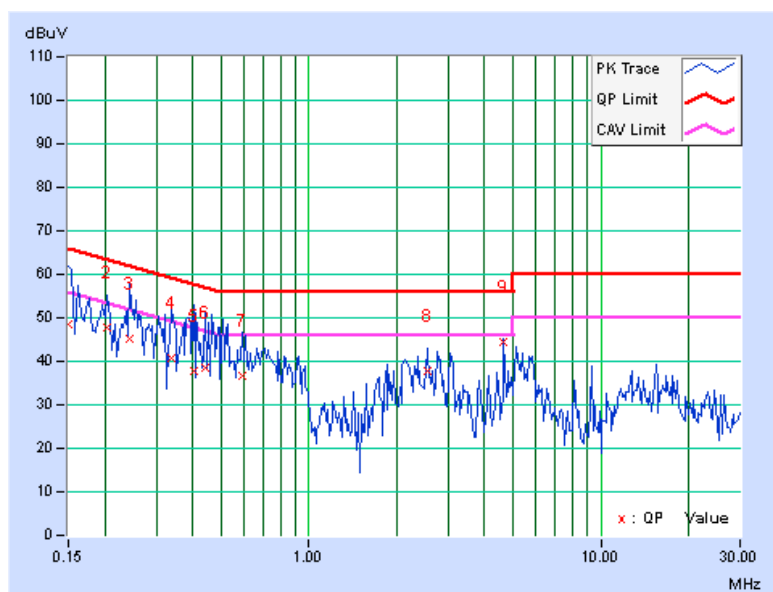

|              |             |                          |                                |
|--------------|-------------|--------------------------|--------------------------------|
| <b>PHASE</b> | Neutral (N) | <b>DETECTOR FUNCTION</b> | Quasi-Peak (QP) / Average (AV) |
|--------------|-------------|--------------------------|--------------------------------|

| No | Freq.<br>[MHz] | Corr.<br>Factor<br>(dB) | Reading Value<br>[dB (uV)] |       | Emission Level<br>[dB (uV)] |       | Limit<br>[dB (uV)] |       | Margin<br>(dB) |        |
|----|----------------|-------------------------|----------------------------|-------|-----------------------------|-------|--------------------|-------|----------------|--------|
|    |                |                         | Q.P.                       | AV.   | Q.P.                        | AV.   | Q.P.               | AV.   | Q.P.           | AV.    |
|    | 1              | 0.15000                 | 0.14                       | 49.48 | 26.53                       | 49.62 | 26.67              | 66.00 | 56.00          | -16.38 |
| 2  | 0.18516        | 0.15                    | 43.26                      | 21.19 | 43.41                       | 21.34 | 64.25              | 54.25 | -20.84         | -32.91 |
| 3  | 0.22812        | 0.16                    | 42.74                      | 20.55 | 42.90                       | 20.71 | 62.52              | 52.52 | -19.62         | -31.81 |
| 4  | 0.27109        | 0.16                    | 41.92                      | 19.45 | 42.08                       | 19.61 | 61.08              | 51.08 | -19.00         | -31.47 |
| 5  | 0.32969        | 0.18                    | 36.84                      | 12.87 | 37.02                       | 13.05 | 59.46              | 49.46 | -22.44         | -36.41 |
| 6  | 0.40000        | 0.19                    | 36.80                      | 12.01 | 36.99                       | 12.20 | 57.85              | 47.85 | -20.86         | -35.65 |
| 7  | 0.54844        | 0.20                    | 32.04                      | 10.79 | 32.24                       | 10.99 | 56.00              | 46.00 | -23.76         | -35.01 |
| 8  | 0.64609        | 0.20                    | 33.26                      | 10.16 | 33.46                       | 10.36 | 56.00              | 46.00 | -22.54         | -35.64 |
| 9  | 2.80078        | 0.30                    | 36.81                      | 24.38 | 37.11                       | 24.68 | 56.00              | 46.00 | -18.89         | -21.32 |

**REMARKS:**

1. Q.P. and AV. are abbreviations of quasi-peak and average individually.
2. The emission levels of other frequencies were very low against the limit.
3. Margin value = Emission level - Limit value
4. Correction factor = Insertion loss + Cable loss
5. Emission Level = Correction Factor + Reading Value.

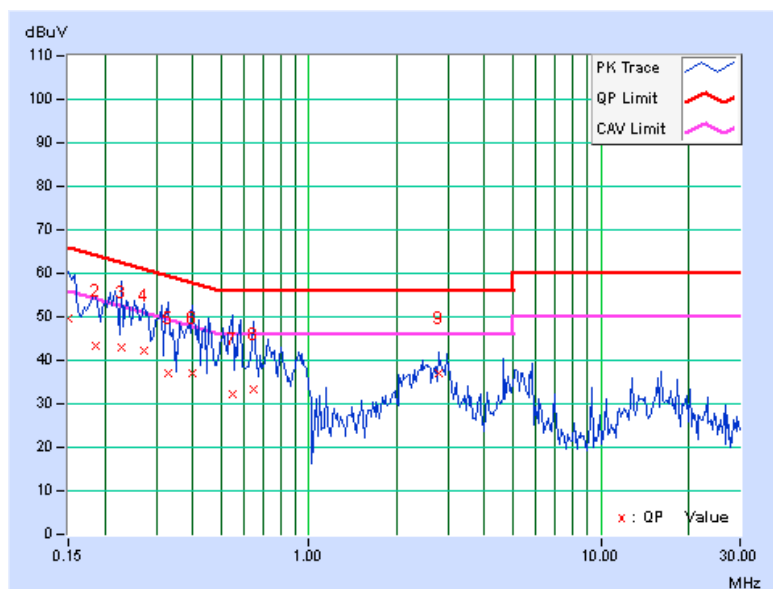



### 5.1.8 TEST RESULTS (MODE 2)

|              |          |                          |                                |
|--------------|----------|--------------------------|--------------------------------|
| <b>PHASE</b> | Line (L) | <b>DETECTOR FUNCTION</b> | Quasi-Peak (QP) / Average (AV) |
|--------------|----------|--------------------------|--------------------------------|

| No | Freq.<br>[MHz] | Corr.<br>Factor<br>(dB) | Reading Value |       | Emission Level |       | Limit     |       | Margin |        |
|----|----------------|-------------------------|---------------|-------|----------------|-------|-----------|-------|--------|--------|
|    |                |                         | [dB (uV)]     |       | [dB (uV)]      |       | [dB (uV)] |       | (dB)   |        |
|    |                |                         | Q.P.          | AV.   | Q.P.           | AV.   | Q.P.      | AV.   | Q.P.   | AV.    |
| 1  | 0.16175        | 0.10                    | 47.73         | 40.95 | 47.83          | 41.05 | 65.37     | 55.37 | -17.55 | -14.33 |
| 2  | 0.20469        | 0.11                    | 44.71         | 27.78 | 44.82          | 27.89 | 63.42     | 53.42 | -18.60 | -25.53 |
| 3  | 0.27891        | 0.13                    | 40.83         | 29.18 | 40.96          | 29.31 | 60.85     | 50.85 | -19.89 | -21.54 |
| 4  | 0.38047        | 0.16                    | 37.03         | 26.31 | 37.19          | 26.47 | 58.27     | 48.27 | -21.08 | -21.80 |
| 5  | 0.46250        | 0.16                    | 36.93         | 14.70 | 37.09          | 14.86 | 56.65     | 46.65 | -19.56 | -31.79 |
| 6  | 0.53672        | 0.16                    | 35.78         | 17.52 | 35.94          | 17.68 | 56.00     | 46.00 | -20.06 | -28.32 |
| 7  | 4.65625        | 0.35                    | 40.76         | 36.72 | 41.11          | 37.07 | 56.00     | 46.00 | -14.89 | -8.93  |

#### REMARKS:

1. Q.P. and AV. are abbreviations of quasi-peak and average individually.
2. The emission levels of other frequencies were very low against the limit.
3. Margin value = Emission level - Limit value
4. Correction factor = Insertion loss + Cable loss
5. Emission Level = Correction Factor + Reading Value.

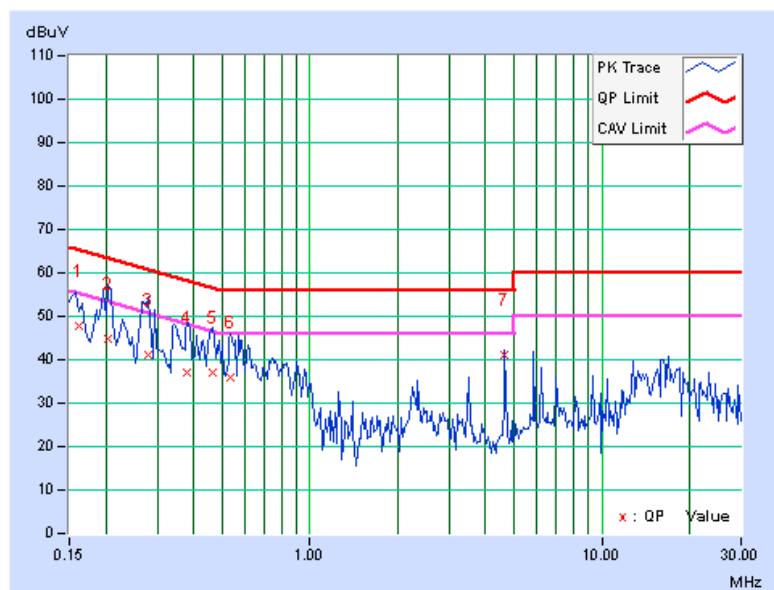

|              |             |                          |                                |
|--------------|-------------|--------------------------|--------------------------------|
| <b>PHASE</b> | Neutral (N) | <b>DETECTOR FUNCTION</b> | Quasi-Peak (QP) / Average (AV) |
|--------------|-------------|--------------------------|--------------------------------|

| No | Freq.<br>[MHz] | Corr.<br>Factor<br>(dB) | Reading Value<br>[dB (uV)] |       | Emission Level<br>[dB (uV)] |       | Limit<br>[dB (uV)] |       | Margin<br>(dB) |        |
|----|----------------|-------------------------|----------------------------|-------|-----------------------------|-------|--------------------|-------|----------------|--------|
|    |                |                         | Q.P.                       | AV.   | Q.P.                        | AV.   | Q.P.               | AV.   | Q.P.           | AV.    |
|    | 1              | 0.16953                 | 0.15                       | 44.90 | 34.71                       | 45.05 | 34.86              | 64.98 | 54.98          | -19.94 |
| 2  | 0.19287        | 0.15                    | 49.29                      | 24.84 | 49.44                       | 24.99 | 63.91              | 53.91 | -14.47         | -28.92 |
| 3  | 0.29063        | 0.17                    | 38.21                      | 19.96 | 38.38                       | 20.13 | 60.51              | 50.51 | -22.13         | -30.38 |
| 4  | 0.34141        | 0.18                    | 37.30                      | 18.02 | 37.48                       | 18.20 | 59.17              | 49.17 | -21.69         | -30.97 |
| 5  | 0.38828        | 0.19                    | 37.56                      | 25.65 | 37.75                       | 25.84 | 58.10              | 48.10 | -20.35         | -22.26 |
| 6  | 0.46250        | 0.19                    | 35.63                      | 13.30 | 35.82                       | 13.49 | 56.65              | 46.65 | -20.82         | -33.15 |
| 7  | 0.55234        | 0.20                    | 34.89                      | 16.02 | 35.09                       | 16.22 | 56.00              | 46.00 | -20.91         | -29.78 |

**REMARKS:**

1. Q.P. and AV. are abbreviations of quasi-peak and average individually.
2. The emission levels of other frequencies were very low against the limit.
3. Margin value = Emission level - Limit value
4. Correction factor = Insertion loss + Cable loss
5. Emission Level = Correction Factor + Reading Value.

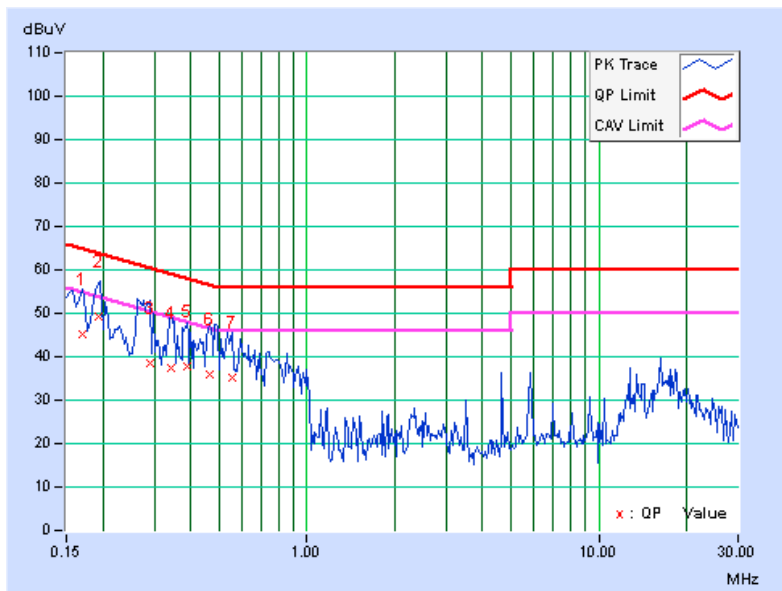

## 5.2 RADIATED AND BANDEDGE EMISSION MEASUREMENT

### 5.2.1 LIMITS OF RADIATED AND BANDEDGE EMISSION MEASUREMENT

Radiated emissions which fall in the restricted bands must comply with the radiated emission limits specified as below table. Other emissions shall be at least 30dB below the highest level of the desired power:

| Frequencies (MHz) | Field strength (microvolts/meter) | Measurement distance (meters) |
|-------------------|-----------------------------------|-------------------------------|
| 0.009-0.490       | 2400/F(kHz)                       | 300                           |
| 0.490-1.705       | 24000/F(kHz)                      | 30                            |
| 1.705-30.0        | 30                                | 30                            |
| 30-88             | 100                               | 3                             |
| 88-216            | 150                               | 3                             |
| 216-960           | 200                               | 3                             |
| Above 960         | 500                               | 3                             |

**NOTE:**

1. The lower limit shall apply at the transition frequencies.
2. Emission level (dBuV/m) = 20 log Emission level (uV/m).
3. For frequencies above 1000MHz, the field strength limits are based on average detector, however, the peak field strength of any emission shall not exceed the maximum permitted average limits, specified above by more than 20dB under any condition of modulation.



A D T

## 5.2.2 TEST INSTRUMENTS

| DESCRIPTION & MANUFACTURER              | MODEL NO.                | SERIAL NO.                          | CALIBRATED DATE | CALIBRATED UNTIL |
|-----------------------------------------|--------------------------|-------------------------------------|-----------------|------------------|
| Spectrum Analyzer<br>Agilent            | E4446A                   | MY48250253                          | Sep. 03, 2012   | Sep. 02, 2013    |
| MXE EMI Receiver<br>Agilent             | N9038A                   | MY51210105                          | Jan. 29, 2013   | Jan. 28, 2014    |
| Pre-Amplifier<br>Mini-Circuits          | ZFL-1000VH2<br>B         | AMP-ZFL-03                          | Nov. 14, 2012   | Nov. 13, 2013    |
| Pre-Amplifier<br>Agilent                | 8449B                    | 3008A02578                          | June 26, 2012   | June 25, 2013    |
| Pre-Amplifier<br>SPACEK LABS            | SLKKa-48-6               | 9K16                                | Nov. 14, 2012   | Nov. 13, 2013    |
| Trilog Broadband Antenna<br>SCHWARZBECK | VULB 9168                | 9168-360                            | Mar. 19, 2013   | Mar. 18, 2014    |
| Horn_Antenna<br>AISI                    | AIH.8018                 | 0000320091110                       | Nov. 19, 2012   | Nov. 18, 2013    |
| Horn_Antenna<br>SCHWARZBECK             | BBHA 9170                | 9170-424                            | Oct. 12, 2012   | Oct. 11, 2013    |
| RF Cable                                | NA                       | RF104-201<br>RF104-203<br>RF104-204 | Dec. 25, 2012   | Dec. 24, 2013    |
| RF Cable                                | NA                       | CHGCAB_001                          | Oct. 06, 2012   | Oct. 05, 2013    |
| Software                                | ADT_Radiated<br>_V8.7.05 | NA                                  | NA              | NA               |
| Antenna Tower & Turn Table<br>CT        | NA                       | NA                                  | NA              | NA               |

### Note:

1. The calibration interval of the above test instruments is 12 months and the calibrations are traceable to NML/ROC and NIST/USA.
2. The horn antenna, preamplifier (model: 8449B) are used only for the measurement of emission frequency above 1GHz if tested.
- 3 The test was performed in 966 Chamber No. G.
4. The FCC Site Registration No. is 966073.
- 5 The VCCI Site Registration No. is G-137.
- 6 The CANADA Site Registration No. is IC 7450H-2.
- 7 Tested Date: Apr. 10, 2013

### 5.2.3 TEST PROCEDURES

- a. The EUT was placed on the top of a rotating table 0.8 meters above the ground at 3 meter chamber room for test. The table was rotated 360 degrees to determine the position of the highest radiation.
- b. The EUT was set 3 meters away from the interference-receiving antenna, which was mounted on the top of a variable-height antenna tower.
- c. The height of antenna is varied from one meter to four meters above the ground to determine the maximum value of the field strength. Both horizontal and vertical polarizations of the antenna are set to make the measurement.
- d. For each suspected emission, the EUT was arranged to its worst case and then the antenna was tuned to heights from 1 meter to 4 meters and the rotatable table was turned from 0 degrees to 360 degrees to find the maximum reading.
- e. The test-receiver system was set to quasi-peak detect function and specified bandwidth with maximum hold mode when the test frequency is below 1 GHz.
- f. The test-receiver system was set to peak and average detect function and specified bandwidth with maximum hold mode when the test frequency is above 1 GHz. If the peak reading value also meets average limit, measurement with the average detector is unnecessary.

**NOTE:**

1. The resolution bandwidth and video bandwidth of test receiver/spectrum analyzer is 120kHz for Quasi-peak detection (QP) at frequency below 1GHz.
2. The resolution bandwidth of test receiver/spectrum analyzer is 1 MHz and the video bandwidth is 3 MHz for Peak detection (PK) at frequency above 1GHz.
3. The resolution bandwidth of test receiver/spectrum analyzer is 1 MHz and the video bandwidth is 10 Hz for Average detection (AV) at frequency above 1GHz.
4. All modes of operation were investigated and the worst-case emissions are reported.

### 5.2.4 DEVIATION FROM TEST STANDARD

No deviation

### 5.2.5 TEST SETUP

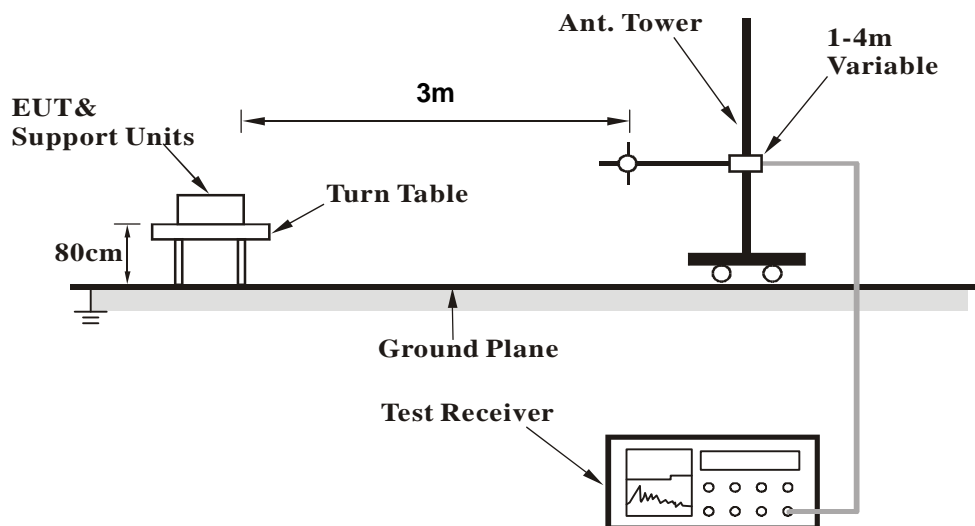

For the actual test configuration, please refer to the related item – Photographs of the Test Configuration.

### 5.2.6 EUT OPERATING CONDITIONS

Same as the 4.1.6

## 5.2.7 TEST RESULTS

### BELOW 1GHz WORST-CASE DATA

#### 802.11n (HT20)

|                        |                |                          |                 |
|------------------------|----------------|--------------------------|-----------------|
| <b>CHANNEL</b>         | TX Channel 165 | <b>DETECTOR FUNCTION</b> | Quasi-Peak (QP) |
| <b>FREQUENCY RANGE</b> | Below 1GHz     |                          |                 |

| ANTENNA POLARITY & TEST DISTANCE: HORIZONTAL AT 3 M |             |                         |                |             |                    |                      |                  |                          |
|-----------------------------------------------------|-------------|-------------------------|----------------|-------------|--------------------|----------------------|------------------|--------------------------|
| NO.                                                 | FREQ. (MHz) | EMISSION LEVEL (dBuV/m) | LIMIT (dBuV/m) | MARGIN (dB) | ANTENNA HEIGHT (m) | TABLE ANGLE (Degree) | RAW VALUE (dBuV) | CORRECTION FACTOR (dB/m) |
| 1                                                   | 104.74      | 30.4 QP                 | 43.5           | -13.1       | 1.50 H             | 360                  | 47.77            | -17.33                   |
| 2                                                   | 148.10      | 34.0 QP                 | 43.5           | -9.5        | 2.00 H             | 64                   | 47.89            | -13.85                   |
| 3                                                   | 579.99      | 30.6 QP                 | 46.0           | -15.4       | 1.00 H             | 360                  | 36.76            | -6.14                    |
| 4                                                   | 625.00      | 34.2 QP                 | 46.0           | -11.8       | 1.00 H             | 360                  | 39.07            | -4.84                    |
| 5                                                   | 676.70      | 34.6 QP                 | 46.0           | -11.4       | 1.00 H             | 360                  | 38.92            | -4.32                    |
| 6                                                   | 750.03      | 32.8 QP                 | 46.0           | -13.2       | 1.00 H             | 45                   | 35.25            | -2.45                    |
| ANTENNA POLARITY & TEST DISTANCE: VERTICAL AT 3 M   |             |                         |                |             |                    |                      |                  |                          |
| NO.                                                 | FREQ. (MHz) | EMISSION LEVEL (dBuV/m) | LIMIT (dBuV/m) | MARGIN (dB) | ANTENNA HEIGHT (m) | TABLE ANGLE (Degree) | RAW VALUE (dBuV) | CORRECTION FACTOR (dB/m) |
| 1                                                   | 77.19       | 30.2 QP                 | 40.0           | -9.8        | 1.00 V             | 301                  | 47.93            | -17.75                   |
| 2                                                   | 483.43      | 30.8 QP                 | 46.0           | -15.2       | 1.00 V             | 327                  | 38.99            | -8.23                    |
| 3                                                   | 531.64      | 35.5 QP                 | 46.0           | -10.5       | 1.00 V             | 252                  | 42.86            | -7.40                    |
| 4                                                   | 579.99      | 33.5 QP                 | 46.0           | -12.5       | 2.00 V             | 360                  | 39.65            | -6.14                    |
| 5                                                   | 628.30      | 36.6 QP                 | 46.0           | -9.4        | 1.50 V             | 311                  | 41.45            | -4.84                    |
| 6                                                   | 676.60      | 32.9 QP                 | 46.0           | -13.1       | 1.50 V             | 257                  | 37.25            | -4.32                    |

#### REMARKS:

1. Emission level (dBuV/m) = Raw Value (dBuV) + Correction Factor (dB/m).
2. Correction Factor (dB/m) = Antenna Factor (dB/m) + Cable Factor (dB).
3. The other emission levels were very low against the limit.
4. Margin value = Emission level – Limit value.



A D T

**ABOVE 1GHz DATA**

**802.11a**

|                        |                |                          |              |
|------------------------|----------------|--------------------------|--------------|
| <b>CHANNEL</b>         | TX Channel 149 | <b>DETECTOR FUNCTION</b> | Peak (PK)    |
| <b>FREQUENCY RANGE</b> | 1GHz ~ 40GHz   |                          | Average (AV) |

**ANTENNA POLARITY & TEST DISTANCE: HORIZONTAL AT 3 M**

| NO. | FREQ. (MHz) | EMISSION LEVEL (dBuV/m) | LIMIT (dBuV/m) | MARGIN (dB) | ANTENNA HEIGHT (m) | TABLE ANGLE (Degree) | RAW VALUE (dBuV) | CORRECTION FACTOR (dB/m) |
|-----|-------------|-------------------------|----------------|-------------|--------------------|----------------------|------------------|--------------------------|
| 1   | 5350.00     | 55.7 PK                 | 74.0           | -18.3       | 1.10 H             | 287                  | 14.55            | 41.15                    |
| 2   | 5350.00     | 42.2 AV                 | 54.0           | -11.8       | 1.10 H             | 287                  | 1.05             | 41.15                    |
| 3   | *5745.00    | 113.0 PK                |                |             | 1.10 H             | 289                  | 70.63            | 42.37                    |
| 4   | *5745.00    | 104.2 AV                |                |             | 1.10 H             | 289                  | 61.83            | 42.37                    |
| 5   | 11490.00    | 62.6 PK                 | 74.0           | -11.4       | 1.00 H             | 246                  | 13.84            | 48.76                    |
| 6   | 11490.00    | 50.5 AV                 | 54.0           | -3.5        | 1.00 H             | 246                  | 1.74             | 48.76                    |

**ANTENNA POLARITY & TEST DISTANCE: VERTICAL AT 3 M**

| NO. | FREQ. (MHz) | EMISSION LEVEL (dBuV/m) | LIMIT (dBuV/m) | MARGIN (dB) | ANTENNA HEIGHT (m) | TABLE ANGLE (Degree) | RAW VALUE (dBuV) | CORRECTION FACTOR (dB/m) |
|-----|-------------|-------------------------|----------------|-------------|--------------------|----------------------|------------------|--------------------------|
| 1   | 5350.00     | 65.0 PK                 | 74.0           | -9.0        | 1.11 V             | 287                  | 23.85            | 41.15                    |
| 2   | 5350.00     | 52.6 AV                 | 54.0           | -1.4        | 1.11 V             | 287                  | 11.45            | 41.15                    |
| 3   | *5745.00    | 123.2 PK                |                |             | 1.11 V             | 287                  | 80.83            | 42.37                    |
| 4   | *5745.00    | 114.1 AV                |                |             | 1.11 V             | 287                  | 71.73            | 42.37                    |
| 5   | 11490.00    | 62.5 PK                 | 74.0           | -11.5       | 1.00 V             | 249                  | 13.74            | 48.76                    |
| 6   | 11490.00    | 50.6 AV                 | 54.0           | -3.4        | 1.00 V             | 249                  | 1.84             | 48.76                    |

**REMARKS:**

1. Emission level (dBuV/m) = Raw Value (dBuV) + Correction Factor (dB/m).
2. Correction Factor (dB/m) = Antenna Factor (dB/m) + Cable Factor (dB).
3. The other emission levels were very low against the limit.
4. Margin value = Emission level – Limit value.
5. " \* ": Fundamental frequency.
6. The limit value is defined as per 15.247.





A D T

|                        |                |                          |              |
|------------------------|----------------|--------------------------|--------------|
| <b>CHANNEL</b>         | TX Channel 157 | <b>DETECTOR FUNCTION</b> | Peak (PK)    |
| <b>FREQUENCY RANGE</b> | 1GHz ~ 40GHz   |                          | Average (AV) |

**ANTENNA POLARITY & TEST DISTANCE: HORIZONTAL AT 3 M**

| NO. | FREQ. (MHz) | EMISSION LEVEL (dBuV/m) | LIMIT (dBuV/m) | MARGIN (dB) | ANTENNA HEIGHT (m) | TABLE ANGLE (Degree) | RAW VALUE (dBuV) | CORRECTION FACTOR (dB/m) |
|-----|-------------|-------------------------|----------------|-------------|--------------------|----------------------|------------------|--------------------------|
| 1   | 5350.00     | 55.0 PK                 | 74.0           | -19.0       | 1.04 H             | 297                  | 13.85            | 41.15                    |
| 2   | 5350.00     | 43.2 AV                 | 54.0           | -10.8       | 1.04 H             | 297                  | 2.05             | 41.15                    |
| 3   | *5785.00    | 112.4 PK                |                |             | 1.05 H             | 281                  | 69.96            | 42.44                    |
| 4   | *5785.00    | 103.6 AV                |                |             | 1.05 H             | 281                  | 61.16            | 42.44                    |
| 5   | 11570.00    | 62.7 PK                 | 74.0           | -11.3       | 1.00 H             | 264                  | 13.99            | 48.71                    |
| 6   | 11570.00    | 50.9 AV                 | 54.0           | -3.1        | 1.00 H             | 264                  | 2.19             | 48.71                    |

**ANTENNA POLARITY & TEST DISTANCE: VERTICAL AT 3 M**

| NO. | FREQ. (MHz) | EMISSION LEVEL (dBuV/m) | LIMIT (dBuV/m) | MARGIN (dB) | ANTENNA HEIGHT (m) | TABLE ANGLE (Degree) | RAW VALUE (dBuV) | CORRECTION FACTOR (dB/m) |
|-----|-------------|-------------------------|----------------|-------------|--------------------|----------------------|------------------|--------------------------|
| 1   | 5350.00     | 65.0 PK                 | 74.0           | -9.0        | 1.11 V             | 287                  | 23.85            | 41.15                    |
| 2   | 5350.00     | 53.2 AV                 | 54.0           | -0.8        | 1.11 V             | 287                  | 12.05            | 41.15                    |
| 3   | *5785.00    | 122.4 PK                |                |             | 1.11 V             | 287                  | 79.96            | 42.44                    |
| 4   | *5785.00    | 113.6 AV                |                |             | 1.11 V             | 287                  | 71.16            | 42.44                    |
| 5   | 11570.00    | 62.6 PK                 | 74.0           | -11.4       | 1.01 V             | 263                  | 13.89            | 48.71                    |
| 6   | 11570.00    | 50.7 AV                 | 54.0           | -3.3        | 1.01 V             | 263                  | 1.99             | 48.71                    |

**REMARKS:**

1. Emission level (dBuV/m) = Raw Value (dBuV) + Correction Factor (dB/m).
2. Correction Factor (dB/m) = Antenna Factor (dB/m) + Cable Factor (dB).
3. The other emission levels were very low against the limit.
4. Margin value = Emission level – Limit value.
5. " \* ": Fundamental frequency.
6. The limit value is defined as per 15.247.



A D T

|                        |                |                          |              |
|------------------------|----------------|--------------------------|--------------|
| <b>CHANNEL</b>         | TX Channel 165 | <b>DETECTOR FUNCTION</b> | Peak (PK)    |
| <b>FREQUENCY RANGE</b> | 1GHz ~ 40GHz   |                          | Average (AV) |

**ANTENNA POLARITY & TEST DISTANCE: HORIZONTAL AT 3 M**

| NO. | FREQ. (MHz) | EMISSION LEVEL (dBuV/m) | LIMIT (dBuV/m) | MARGIN (dB) | ANTENNA HEIGHT (m) | TABLE ANGLE (Degree) | RAW VALUE (dBuV) | CORRECTION FACTOR (dB/m) |
|-----|-------------|-------------------------|----------------|-------------|--------------------|----------------------|------------------|--------------------------|
| 1   | 5350.00     | 54.0 PK                 | 74.0           | -20.0       | 1.04 H             | 296                  | 12.85            | 41.15                    |
| 2   | 5350.00     | 43.2 AV                 | 54.0           | -10.8       | 1.04 H             | 296                  | 2.05             | 41.15                    |
| 3   | *5825.00    | 108.5 PK                |                |             | 1.10 H             | 280                  | 65.93            | 42.57                    |
| 4   | *5825.00    | 100.2 AV                |                |             | 1.10 H             | 280                  | 57.63            | 42.57                    |
| 5   | 11650.00    | 60.9 PK                 | 74.0           | -13.1       | 1.25 H             | 296                  | 11.98            | 48.92                    |
| 6   | 11650.00    | 48.8 AV                 | 54.0           | -5.2        | 1.25 H             | 296                  | -0.12            | 48.92                    |

**ANTENNA POLARITY & TEST DISTANCE: VERTICAL AT 3 M**

| NO. | FREQ. (MHz) | EMISSION LEVEL (dBuV/m) | LIMIT (dBuV/m) | MARGIN (dB) | ANTENNA HEIGHT (m) | TABLE ANGLE (Degree) | RAW VALUE (dBuV) | CORRECTION FACTOR (dB/m) |
|-----|-------------|-------------------------|----------------|-------------|--------------------|----------------------|------------------|--------------------------|
| 1   | 5350.00     | 64.0 PK                 | 74.0           | -10.0       | 1.09 V             | 290                  | 22.85            | 41.15                    |
| 2   | 5350.00     | 53.2 AV                 | 54.0           | -0.8        | 1.09 V             | 290                  | 12.05            | 41.15                    |
| 3   | *5825.00    | 118.5 PK                |                |             | 1.09 V             | 290                  | 75.93            | 42.57                    |
| 4   | *5825.00    | 110.2 AV                |                |             | 1.09 V             | 290                  | 67.63            | 42.57                    |
| 5   | 11650.00    | 61.3 PK                 | 74.0           | -12.7       | 1.16 V             | 291                  | 12.38            | 48.92                    |
| 6   | 11650.00    | 49.0 AV                 | 54.0           | -5.0        | 1.16 V             | 291                  | 0.08             | 48.92                    |

**REMARKS:**

1. Emission level (dBuV/m) = Raw Value (dBuV) + Correction Factor (dB/m).
2. Correction Factor (dB/m) = Antenna Factor (dB/m) + Cable Factor (dB).
3. The other emission levels were very low against the limit.
4. Margin value = Emission level – Limit value.
5. " \* ": Fundamental frequency.
6. The limit value is defined as per 15.247.

**802.11n (HT20)**

|                        |                |                              |              |
|------------------------|----------------|------------------------------|--------------|
| <b>CHANNEL</b>         | TX Channel 149 | <b>DETECTOR<br/>FUNCTION</b> | Peak (PK)    |
| <b>FREQUENCY RANGE</b> | 1GHz ~ 40GHz   |                              | Average (AV) |

| ANTENNA POLARITY & TEST DISTANCE: HORIZONTAL AT 3 M |                |                               |                   |                |                          |                            |                        |                                |
|-----------------------------------------------------|----------------|-------------------------------|-------------------|----------------|--------------------------|----------------------------|------------------------|--------------------------------|
| NO.                                                 | FREQ.<br>(MHz) | EMISSION<br>LEVEL<br>(dBuV/m) | LIMIT<br>(dBuV/m) | MARGIN<br>(dB) | ANTENNA<br>HEIGHT<br>(m) | TABLE<br>ANGLE<br>(Degree) | RAW<br>VALUE<br>(dBuV) | CORRECTION<br>FACTOR<br>(dB/m) |
| 1                                                   | 5350.00        | 54.8 PK                       | 74.0              | -19.2          | 1.07 H                   | 281                        | 13.65                  | 41.15                          |
| 2                                                   | 5350.00        | 43.3 AV                       | 54.0              | -10.7          | 1.07 H                   | 281                        | 2.15                   | 41.15                          |
| 3                                                   | *5745.00       | 113.1 PK                      |                   |                | 1.09 H                   | 269                        | 70.73                  | 42.37                          |
| 4                                                   | *5745.00       | 103.1 AV                      |                   |                | 1.09 H                   | 269                        | 60.73                  | 42.37                          |
| 5                                                   | 11490.00       | 62.0 PK                       | 74.0              | -12.0          | 1.22 H                   | 88                         | 13.24                  | 48.76                          |
| 6                                                   | 11490.00       | 51.5 AV                       | 54.0              | -2.5           | 1.22 H                   | 88                         | 2.74                   | 48.76                          |
| ANTENNA POLARITY & TEST DISTANCE: VERTICAL AT 3 M   |                |                               |                   |                |                          |                            |                        |                                |
| NO.                                                 | FREQ.<br>(MHz) | EMISSION<br>LEVEL<br>(dBuV/m) | LIMIT<br>(dBuV/m) | MARGIN<br>(dB) | ANTENNA<br>HEIGHT<br>(m) | TABLE<br>ANGLE<br>(Degree) | RAW<br>VALUE<br>(dBuV) | CORRECTION<br>FACTOR<br>(dB/m) |
| 1                                                   | 5350.00        | 64.8 PK                       | 74.0              | -9.2           | 1.10 V                   | 284                        | 23.65                  | 41.15                          |
| 2                                                   | 5350.00        | 53.3 AV                       | 54.0              | -0.7           | 1.10 V                   | 284                        | 12.15                  | 41.15                          |
| 3                                                   | *5745.00       | 123.1 PK                      |                   |                | 1.10 V                   | 284                        | 80.73                  | 42.37                          |
| 4                                                   | *5745.00       | 113.1 AV                      |                   |                | 1.10 V                   | 284                        | 70.73                  | 42.37                          |
| 5                                                   | 11490.00       | 62.5 PK                       | 74.0              | -11.5          | 1.22 V                   | 102                        | 13.74                  | 48.76                          |
| 6                                                   | 11490.00       | 51.9 AV                       | 54.0              | -2.1           | 1.22 V                   | 102                        | 3.14                   | 48.76                          |

**REMARKS:**

1. Emission level (dBuV/m) = Raw Value (dBuV) + Correction Factor (dB/m).
2. Correction Factor (dB/m) = Antenna Factor (dB/m) + Cable Factor (dB).
3. The other emission levels were very low against the limit.
4. Margin value = Emission level – Limit value.
5. " \* ": Fundamental frequency.
6. The limit value is defined as per 15.247.



A D T

|                        |                |                          |              |
|------------------------|----------------|--------------------------|--------------|
| <b>CHANNEL</b>         | TX Channel 157 | <b>DETECTOR FUNCTION</b> | Peak (PK)    |
| <b>FREQUENCY RANGE</b> | 1GHz ~ 40GHz   |                          | Average (AV) |

**ANTENNA POLARITY & TEST DISTANCE: HORIZONTAL AT 3 M**

| NO. | FREQ. (MHz) | EMISSION LEVEL (dBuV/m) | LIMIT (dBuV/m) | MARGIN (dB) | ANTENNA HEIGHT (m) | TABLE ANGLE (Degree) | RAW VALUE (dBuV) | CORRECTION FACTOR (dB/m) |
|-----|-------------|-------------------------|----------------|-------------|--------------------|----------------------|------------------|--------------------------|
| 1   | 5350.00     | 56.1 PK                 | 74.0           | -17.9       | 1.06 H             | 282                  | 14.95            | 41.15                    |
| 2   | 5350.00     | 43.4 AV                 | 54.0           | -10.6       | 1.06 H             | 282                  | 2.25             | 41.15                    |
| 3   | *5785.00    | 111.3 PK                |                |             | 1.08 H             | 300                  | 68.86            | 42.44                    |
| 4   | *5785.00    | 102.5 AV                |                |             | 1.08 H             | 300                  | 60.06            | 42.44                    |
| 5   | 11570.00    | 62.0 PK                 | 74.0           | -12.0       | 1.25 H             | 77                   | 13.29            | 48.71                    |
| 6   | 11570.00    | 51.3 AV                 | 54.0           | -2.7        | 1.25 H             | 77                   | 2.59             | 48.71                    |

**ANTENNA POLARITY & TEST DISTANCE: VERTICAL AT 3 M**

| NO. | FREQ. (MHz)    | EMISSION LEVEL (dBuV/m) | LIMIT (dBuV/m) | MARGIN (dB) | ANTENNA HEIGHT (m) | TABLE ANGLE (Degree) | RAW VALUE (dBuV) | CORRECTION FACTOR (dB/m) |
|-----|----------------|-------------------------|----------------|-------------|--------------------|----------------------|------------------|--------------------------|
| 1   | 5350.00        | 66.1 PK                 | 74.0           | -7.9        | 1.09 V             | 286                  | 24.95            | 41.15                    |
| 2   | <b>5350.00</b> | <b>53.4 AV</b>          | <b>54.0</b>    | <b>-0.6</b> | <b>1.09 V</b>      | <b>286</b>           | <b>12.25</b>     | <b>41.15</b>             |
| 3   | *5785.00       | 121.3 PK                |                |             | 1.09 V             | 286                  | 78.86            | 42.44                    |
| 4   | *5785.00       | 112.5 AV                |                |             | 1.09 V             | 286                  | 70.06            | 42.44                    |
| 5   | 11570.00       | 61.6 PK                 | 74.0           | -12.4       | 1.20 V             | 93                   | 12.89            | 48.71                    |
| 6   | 11570.00       | 51.0 AV                 | 54.0           | -3.0        | 1.20 V             | 93                   | 2.29             | 48.71                    |

**REMARKS:**

1. Emission level (dBuV/m) = Raw Value (dBuV) + Correction Factor (dB/m).
2. Correction Factor (dB/m) = Antenna Factor (dB/m) + Cable Factor (dB).
3. The other emission levels were very low against the limit.
4. Margin value = Emission level – Limit value.
5. " \* ": Fundamental frequency.
6. The limit value is defined as per 15.247.



A D T

|                        |                |                          |              |
|------------------------|----------------|--------------------------|--------------|
| <b>CHANNEL</b>         | TX Channel 165 | <b>DETECTOR FUNCTION</b> | Peak (PK)    |
| <b>FREQUENCY RANGE</b> | 1GHz ~ 40GHz   |                          | Average (AV) |

**ANTENNA POLARITY & TEST DISTANCE: HORIZONTAL AT 3 M**

| NO. | FREQ. (MHz) | EMISSION LEVEL (dBuV/m) | LIMIT (dBuV/m) | MARGIN (dB) | ANTENNA HEIGHT (m) | TABLE ANGLE (Degree) | RAW VALUE (dBuV) | CORRECTION FACTOR (dB/m) |
|-----|-------------|-------------------------|----------------|-------------|--------------------|----------------------|------------------|--------------------------|
| 1   | 5460.00     | 54.5 PK                 | 74.0           | -19.5       | 1.07 H             | 260                  | 12.99            | 41.51                    |
| 2   | 5460.00     | 43.3 AV                 | 54.0           | -10.7       | 1.07 H             | 260                  | 1.79             | 41.51                    |
| 3   | *5825.00    | 110.9 PK                |                |             | 1.10 H             | 295                  | 68.33            | 42.57                    |
| 4   | *5825.00    | 102.7 AV                |                |             | 1.10 H             | 295                  | 60.13            | 42.57                    |
| 5   | 11650.00    | 61.9 PK                 | 74.0           | -12.1       | 1.24 H             | 95                   | 12.98            | 48.92                    |
| 6   | 11650.00    | 51.3 AV                 | 54.0           | -2.7        | 1.24 H             | 95                   | 2.38             | 48.92                    |

**ANTENNA POLARITY & TEST DISTANCE: VERTICAL AT 3 M**

| NO. | FREQ. (MHz) | EMISSION LEVEL (dBuV/m) | LIMIT (dBuV/m) | MARGIN (dB) | ANTENNA HEIGHT (m) | TABLE ANGLE (Degree) | RAW VALUE (dBuV) | CORRECTION FACTOR (dB/m) |
|-----|-------------|-------------------------|----------------|-------------|--------------------|----------------------|------------------|--------------------------|
| 1   | 5460.00     | 64.5 PK                 | 74.0           | -9.5        | 1.31 V             | 282                  | 22.99            | 41.51                    |
| 2   | 5460.00     | 53.3 AV                 | 54.0           | -0.7        | 1.31 V             | 282                  | 11.79            | 41.51                    |
| 3   | *5825.00    | 120.9 PK                |                |             | 1.31 V             | 282                  | 78.33            | 42.57                    |
| 4   | *5825.00    | 112.7 AV                |                |             | 1.31 V             | 282                  | 70.13            | 42.57                    |
| 5   | 11650.00    | 62.0 PK                 | 74.0           | -12.0       | 1.17 V             | 72                   | 13.08            | 48.92                    |
| 6   | 11650.00    | 51.8 AV                 | 54.0           | -2.2        | 1.17 V             | 72                   | 2.88             | 48.92                    |

**REMARKS:**

1. Emission level (dBuV/m) = Raw Value (dBuV) + Correction Factor (dB/m).
2. Correction Factor (dB/m) = Antenna Factor (dB/m) + Cable Factor (dB).
3. The other emission levels were very low against the limit.
4. Margin value = Emission level – Limit value.
5. " \* ": Fundamental frequency.
6. The limit value is defined as per 15.247.



A D T

802.11n (HT40)

|                 |                |                      |              |
|-----------------|----------------|----------------------|--------------|
| CHANNEL         | TX Channel 151 | DETECTOR<br>FUNCTION | Peak (PK)    |
| FREQUENCY RANGE | 1GHz ~ 40GHz   |                      | Average (AV) |

**ANTENNA POLARITY & TEST DISTANCE: HORIZONTAL AT 3 M**

| NO. | FREQ.<br>(MHz) | EMISSION<br>LEVEL<br>(dBuV/m) | LIMIT<br>(dBuV/m) | MARGIN<br>(dB) | ANTENNA<br>HEIGHT<br>(m) | TABLE<br>ANGLE<br>(Degree) | RAW<br>VALUE<br>(dBuV) | CORRECTION<br>FACTOR<br>(dB/m) |
|-----|----------------|-------------------------------|-------------------|----------------|--------------------------|----------------------------|------------------------|--------------------------------|
| 1   | 5350.00        | 55.7 PK                       | 74.0              | -18.3          | 1.11 H                   | 274                        | 14.55                  | 41.15                          |
| 2   | 5350.00        | 43.4 AV                       | 54.0              | -10.6          | 1.11 H                   | 274                        | 2.25                   | 41.15                          |
| 3   | *5755.00       | 110.3 PK                      |                   |                | 1.04 H                   | 288                        | 67.91                  | 42.39                          |
| 4   | *5755.00       | 100.4 AV                      |                   |                | 1.04 H                   | 288                        | 58.01                  | 42.39                          |
| 5   | 11510.00       | 62.1 PK                       | 74.0              | -11.9          | 1.19 H                   | 74                         | 13.36                  | 48.74                          |
| 6   | 11510.00       | 51.4 AV                       | 54.0              | -2.6           | 1.19 H                   | 74                         | 2.66                   | 48.74                          |

**ANTENNA POLARITY & TEST DISTANCE: VERTICAL AT 3 M**

| NO. | FREQ.<br>(MHz) | EMISSION<br>LEVEL<br>(dBuV/m) | LIMIT<br>(dBuV/m) | MARGIN<br>(dB) | ANTENNA<br>HEIGHT<br>(m) | TABLE<br>ANGLE<br>(Degree) | RAW<br>VALUE<br>(dBuV) | CORRECTION<br>FACTOR<br>(dB/m) |
|-----|----------------|-------------------------------|-------------------|----------------|--------------------------|----------------------------|------------------------|--------------------------------|
| 1   | 5350.00        | 65.7 PK                       | 74.0              | -8.3           | 1.10 V                   | 284                        | 24.55                  | 41.15                          |
| 2   | <b>5350.00</b> | <b>53.4 AV</b>                | <b>54.0</b>       | <b>-0.6</b>    | <b>1.10 V</b>            | <b>284</b>                 | <b>12.25</b>           | <b>41.15</b>                   |
| 3   | *5755.00       | 120.3 PK                      |                   |                | 1.10 V                   | 283                        | 77.91                  | 42.39                          |
| 4   | *5755.00       | 110.4 AV                      |                   |                | 1.10 V                   | 283                        | 68.01                  | 42.39                          |
| 5   | 11510.00       | 62.2 PK                       | 74.0              | -11.8          | 1.23 V                   | 86                         | 13.46                  | 48.74                          |
| 6   | 11510.00       | 51.9 AV                       | 54.0              | -2.1           | 1.23 V                   | 86                         | 3.16                   | 48.74                          |

**REMARKS:**

1. Emission level (dBuV/m) = Raw Value (dBuV) + Correction Factor (dB/m).
2. Correction Factor (dB/m) = Antenna Factor (dB/m) + Cable Factor (dB).
3. The other emission levels were very low against the limit.
4. Margin value = Emission level – Limit value.
5. " \* ": Fundamental frequency.
6. The limit value is defined as per 15.247.



A D T

|                        |                |                          |              |
|------------------------|----------------|--------------------------|--------------|
| <b>CHANNEL</b>         | TX Channel 159 | <b>DETECTOR FUNCTION</b> | Peak (PK)    |
| <b>FREQUENCY RANGE</b> | 1GHz ~ 40GHz   |                          | Average (AV) |

**ANTENNA POLARITY & TEST DISTANCE: HORIZONTAL AT 3 M**

| NO. | FREQ. (MHz) | EMISSION LEVEL (dBuV/m) | LIMIT (dBuV/m) | MARGIN (dB) | ANTENNA HEIGHT (m) | TABLE ANGLE (Degree) | RAW VALUE (dBuV) | CORRECTION FACTOR (dB/m) |
|-----|-------------|-------------------------|----------------|-------------|--------------------|----------------------|------------------|--------------------------|
| 1   | 5350.00     | 54.7 PK                 | 74.0           | -19.3       | 1.07 H             | 272                  | 13.55            | 41.15                    |
| 2   | 5350.00     | 43.2 AV                 | 54.0           | -10.8       | 1.07 H             | 272                  | 2.05             | 41.15                    |
| 3   | *5795.00    | 107.3 PK                |                |             | 1.06 H             | 273                  | 64.85            | 42.45                    |
| 4   | *5795.00    | 98.5 AV                 |                |             | 1.06 H             | 273                  | 56.05            | 42.45                    |
| 5   | 11590.00    | 62.3 PK                 | 74.0           | -11.7       | 1.26 H             | 92                   | 13.60            | 48.70                    |
| 6   | 11590.00    | 51.6 AV                 | 54.0           | -2.4        | 1.26 H             | 92                   | 2.90             | 48.70                    |

**ANTENNA POLARITY & TEST DISTANCE: VERTICAL AT 3 M**

| NO. | FREQ. (MHz) | EMISSION LEVEL (dBuV/m) | LIMIT (dBuV/m) | MARGIN (dB) | ANTENNA HEIGHT (m) | TABLE ANGLE (Degree) | RAW VALUE (dBuV) | CORRECTION FACTOR (dB/m) |
|-----|-------------|-------------------------|----------------|-------------|--------------------|----------------------|------------------|--------------------------|
| 1   | 5350.00     | 64.7 PK                 | 74.0           | -9.3        | 1.09 V             | 283                  | 23.55            | 41.15                    |
| 2   | 5350.00     | 53.2 AV                 | 54.0           | -0.8        | 1.09 V             | 283                  | 12.05            | 41.15                    |
| 3   | *5795.00    | 117.3 PK                |                |             | 1.09 V             | 283                  | 74.85            | 42.45                    |
| 4   | *5795.00    | 108.5 AV                |                |             | 1.09 V             | 283                  | 66.05            | 42.45                    |
| 5   | 11590.00    | 61.8 PK                 | 74.0           | -12.2       | 1.23 V             | 91                   | 13.10            | 48.70                    |
| 6   | 11590.00    | 51.3 AV                 | 54.0           | -2.7        | 1.23 V             | 91                   | 2.60             | 48.70                    |

**REMARKS:**

1. Emission level (dBuV/m) = Raw Value (dBuV) + Correction Factor (dB/m).
2. Correction Factor (dB/m) = Antenna Factor (dB/m) + Cable Factor (dB).
3. The other emission levels were very low against the limit.
4. Margin value = Emission level – Limit value.
5. " \* ": Fundamental frequency.
6. The limit value is defined as per 15.247.

### 5.3 6dB BANDWIDTH MEASUREMENT

#### 5.3.1 LIMITS OF 6dB BANDWIDTH MEASUREMENT

The minimum of 6dB Bandwidth Measurement is 0.5 MHz.

#### 5.3.2 TEST INSTRUMENTS

| DESCRIPTION & MANUFACTURER | MODEL NO. | SERIAL NO. | CALIBRATED DATE | CALIBRATED UNTIL |
|----------------------------|-----------|------------|-----------------|------------------|
| R&S SPECTRUM ANALYZER      | FSP40     | 100037     | Nov. 01, 2012   | Oct. 31, 2013    |

**Note:**

1. The calibration interval of the above test instruments is 12 months and the calibrations are traceable to NML/ROC and NIST/USA.
2. Tested date : Apr. 11, 2013

#### 5.3.3 TEST PROCEDURE

1. Set resolution bandwidth (RBW) = 100kHz
2. Set the video bandwidth (VBW)  $\geq 3 \times$  RBW, Detector = Peak.
3. Trace mode = max hold.
4. Sweep = auto couple.
5. Measure the maximum width of the emission that is constrained by the frequencies associated with the two amplitude points (upper and lower) that are attenuated by 6 dB relative to the maximum level measured in the fundamental emission

#### 5.3.4 DEVIATION FROM TEST STANDARD

No deviation

#### 5.3.5 TEST SETUP

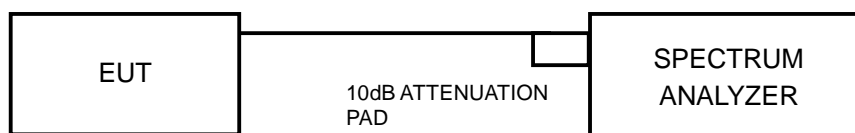

#### 5.3.6 EUT OPERATING CONDITIONS

The software provided by client to enable the EUT under transmission condition continuously at lowest, middle and highest channel frequencies individually.





A D T

### 5.3.7 TEST RESULTS

#### 802.11a

| CHANNEL | FREQUENCY (MHz) | 6dB BANDWIDTH (MHz) | MINIMUM LIMIT (MHz) | PASS / FAIL |
|---------|-----------------|---------------------|---------------------|-------------|
| 149     | 5745            | 15.72               | 0.5                 | PASS        |
| 157     | 5785            | 16.09               | 0.5                 | PASS        |
| 165     | 5825            | 15.77               | 0.5                 | PASS        |

#### 802.11n (HT20)

| CHANNEL | CHANNEL FREQUENCY (MHz) | 6dB BANDWIDTH (MHz) |         | MINIMUM LIMIT (MHz) | PASS / FAIL |
|---------|-------------------------|---------------------|---------|---------------------|-------------|
|         |                         | CHAIN 0             | CHAIN 1 |                     |             |
| 149     | 5745                    | 16.58               | 16.58   | 0.5                 | PASS        |
| 157     | 5785                    | 16.09               | 16.37   | 0.5                 | PASS        |
| 165     | 5825                    | 16.08               | 16.12   | 0.5                 | PASS        |

#### 802.11n (HT40)

| CHANNEL | CHANNEL FREQUENCY (MHz) | 6dB BANDWIDTH (MHz) |         | MINIMUM LIMIT (MHz) | PASS / FAIL |
|---------|-------------------------|---------------------|---------|---------------------|-------------|
|         |                         | CHAIN 0             | CHAIN 1 |                     |             |
| 151     | 5755                    | 35.22               | 35.57   | 0.5                 | PASS        |
| 159     | 5795                    | 34.26               | 35.40   | 0.5                 | PASS        |

## 5.4 CONDUCTED OUTPUT POWER MEASUREMENT

### 5.4.1 LIMITS OF CONDUCTED OUTPUT POWER MEASUREMENT

For systems using digital modulation in the 5725 –5850 MHz band: 1 Watt (30dBm)

Per KDB 662911 D01 Multiple Transmitter Output v01r02 Method of conducted output power measurement on IEEE 802.11 devices,

- Array Gain = 0 dB (i.e., no array gain) for NANT  $\leq$  4;
- Array Gain = 0 dB (i.e., no array gain) for channel widths  $\geq$  40 MHz for any NANT;
- Array Gain = 5 log(NANT/NSS) dB or 3 dB, whichever is less for 20-MHz channel widths with NANT  $\geq$  5.

For power measurements on all other devices: Array Gain = 10 log(NANT/NSS) dB.

### 5.4.2 INSTRUMENTS

| DESCRIPTION & MANUFACTURER | MODEL NO. | SERIAL NO. | CALIBRATED DATE | CALIBRATED UNTIL |
|----------------------------|-----------|------------|-----------------|------------------|
| Power Meter                | ML2495A   | 0824006    | May 10, 2012    | May 09, 2013     |
| Power Sensor               | MA2411B   | 0738172    | May 10, 2012    | May 09, 2013     |

- Note:**
3. The calibration interval of the above test instruments is 12 months and the calibrations are traceable to NML/ROC and NIST/USA.
  4. Tested date : Apr. 11, 2013

### 5.4.3 TEST PROCEDURES

The peak power sensor was used on the output port of the EUT. A power meter was used to read the response of the peak power sensor. Record the peak power level.

### 5.4.4 DEVIATION FROM TEST STANDARD

No deviation.

### 5.4.5 TEST SETUP

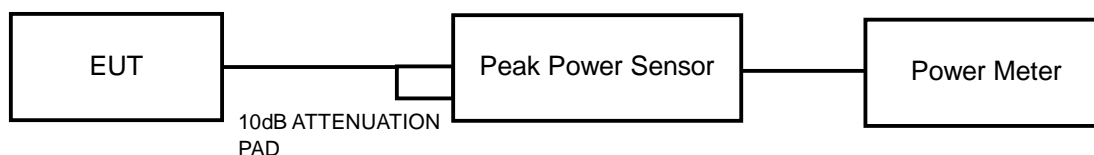

#### 5.4.6 EUT OPERATING CONDITIONS

Same as Item 5.3.6



A D T

## 5.4.7 TEST RESULTS

### 802.11a

| CHANNEL | FREQUENCY (MHz) | PEAK POWER (mW) | PEAK POWER (dBm) | LIMIT (dBm) | PASS/FAIL |
|---------|-----------------|-----------------|------------------|-------------|-----------|
| 149     | 5745            | 301.301         | 24.79            | 30.00       | PASS      |
| 157     | 5785            | 319.890         | 25.05            | 30.00       | PASS      |
| 165     | 5825            | 359.749         | 25.56            | 30.00       | PASS      |

### 802.11n (HT20)

| CHAN. | CHAN. FREQ. (MHz) | PEAK POWER (dBm) |         | TOTAL POWER (mW) | TOTAL POWER (dBm) | LIMIT (dBm) | PASS / FAIL |
|-------|-------------------|------------------|---------|------------------|-------------------|-------------|-------------|
|       |                   | CHAIN 0          | CHAIN 1 |                  |                   |             |             |
| 149   | 5745              | 24.83            | 24.93   | 615.261          | 27.89             | 30.00       | PASS        |
| 157   | 5785              | 25.16            | 25.07   | 649.461          | 28.13             | 30.00       | PASS        |
| 165   | 5825              | 25.62            | 25.26   | 700.492          | 28.45             | 30.00       | PASS        |

### 802.11n (HT40)

| CHAN. | CHAN. FREQ. (MHz) | PEAK POWER (dBm) |         | TOTAL POWER (mW) | TOTAL POWER (dBm) | LIMIT (dBm) | PASS / FAIL |
|-------|-------------------|------------------|---------|------------------|-------------------|-------------|-------------|
|       |                   | CHAIN 0          | CHAIN 1 |                  |                   |             |             |
| 151   | 5755              | 24.86            | 24.81   | 608.887          | 27.85             | 30.00       | PASS        |
| 159   | 5795              | 25.24            | 25.06   | 654.822          | 28.16             | 30.00       | PASS        |



A D T

## 5.5 AVERAGE OUTPUT POWER

### 5.5.1 FOR REFERENCE.

### 5.5.2 TEST INSTRUMENTS

| DESCRIPTION & MANUFACTURER | MODEL NO. | SERIAL NO. | CALIBRATED DATE | CALIBRATED UNTIL |
|----------------------------|-----------|------------|-----------------|------------------|
| Power Meter                | ML2495A   | 0824006    | May 10, 2012    | May 09, 2013     |
| Power Sensor               | MA2411B   | 0738172    | May 10, 2012    | May 09, 2013     |

**Note:**

1. The calibration interval of the above test instruments is 12 months and the calibrations are traceable to NML/ROC and NIST/USA.
2. Tested date : Apr. 11, 2013

### 5.5.3 TEST PROCEDURES

The average power sensor was used on the output port of the EUT. A power meter was used to read the response of the power sensor. Record the power level.

### 5.5.4 TEST SETUP

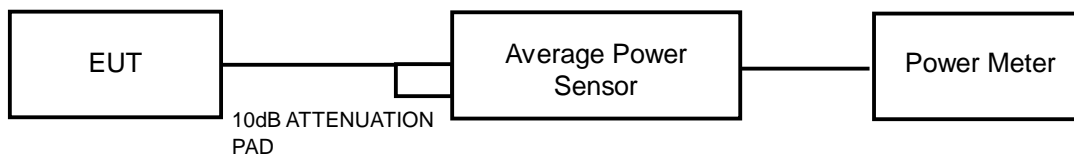

### 5.5.5 EUT OPERATING CONDITIONS

Same as Item 4.3.6



A D T

## 5.5.6 TEST RESULTS

### 802.11a

| CHAN. | FREQUENCY (MHz) | AVERAGE POWER (mW) | AVERAGE POWER (dBm) |
|-------|-----------------|--------------------|---------------------|
| 149   | 5745            | 206.063            | 23.14               |
| 157   | 5785            | 261.818            | 24.18               |
| 165   | 5825            | 170.216            | 22.31               |

### 802.11n (HT20)

| CHAN. | FREQUENCY (MHz) | AVERAGE POWER (dBm) |         | TOTAL POWER (mW) | TOTAL POWER (dBm) |
|-------|-----------------|---------------------|---------|------------------|-------------------|
|       |                 | CHAIN 0             | CHAIN 1 |                  |                   |
| 149   | 5745            | 22.76               | 23.36   | 405.569          | 26.08             |
| 157   | 5785            | 22.61               | 23.13   | 387.979          | 25.89             |
| 165   | 5825            | 22.05               | 22.66   | 344.827          | 25.38             |

### 802.11n (HT40)

| CHAN. | FREQUENCY (MHz) | AVERAGE POWER (dBm) |         | TOTAL POWER (mW) | TOTAL POWER (dBm) |
|-------|-----------------|---------------------|---------|------------------|-------------------|
|       |                 | CHAIN 0             | CHAIN 1 |                  |                   |
| 151   | 5755            | 21.58               | 21.53   | 286.113          | 24.57             |
| 159   | 5795            | 23.91               | 23.71   | 481.000          | 26.82             |

## 5.6 POWER SPECTRAL DENSITY MEASUREMENT

### 5.6.1 LIMITS OF POWER SPECTRAL DENSITY MEASUREMENT

The Maximum of Power Spectral Density Measurement is 8dBm.

### 5.6.2 TEST INSTRUMENTS

| DESCRIPTION & MANUFACTURER | MODEL NO. | SERIAL NO. | CALIBRATED DATE | CALIBRATED UNTIL |
|----------------------------|-----------|------------|-----------------|------------------|
| R&S Spectrum Analyzer      | FSP40     | 100037     | Nov. 01, 2012   | Oct. 31, 2013    |

**Note:**

1. The calibration interval of the above test instruments is 12 months and the calibrations are traceable to NML/ROC and NIST/USA.
2. Tested date : Apr. 11, 2013

### 5.6.3 TEST PROCEDURE

1. Set the RBW = 3 kHz, VBW =10 kHz, Detector = peak.
2. Sweep time = auto couple, Trace mode = max hold, allow trace to fully stabilize.
3. Use the peak marker function to determine the maximum amplitude level.

### 5.6.4 DEVIATION FROM TEST STANDARD

No deviation

### 5.6.5 TEST SETUP

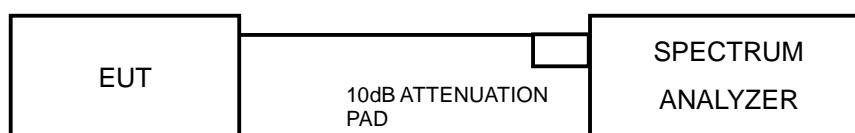

### 5.6.6 EUT OPERATING CONDITION

Same as Item 4.3.6



A D T

## 5.6.7 TEST RESULTS

### 802.11a

| Channel | FREQUENCY (MHz) | PSD (dBm/3kHz) | Limit (dBm/3kHz) | PASS /FAIL |
|---------|-----------------|----------------|------------------|------------|
| 149     | 5745            | -1.37          | 8.00             | PASS       |
| 157     | 5785            | -1.85          | 8.00             | PASS       |
| 165     | 5825            | -1.69          | 8.00             | PASS       |

### 802.11n (HT20)

| TX chain | Channel | FREQ. (MHz) | PSD (dBm/3kHz) | 10 log (N=2) dB | Total PSD (dBm/3kHz) | Limit (dBm/3kHz) | PASS /FAIL |
|----------|---------|-------------|----------------|-----------------|----------------------|------------------|------------|
| 0        | 149     | 5745        | -2.34          | 3.01            | 0.67                 | 6.28             | PASS       |
|          | 157     | 5785        | -1.80          | 3.01            | 1.21                 | 6.28             | PASS       |
|          | 165     | 5825        | -4.53          | 3.01            | -1.52                | 6.28             | PASS       |
| 1        | 149     | 5745        | -1.94          | 3.01            | 1.07                 | 6.28             | PASS       |
|          | 157     | 5785        | -0.95          | 3.01            | 2.06                 | 6.28             | PASS       |
|          | 165     | 5825        | -0.68          | 3.01            | 2.33                 | 6.28             | PASS       |

**NOTE:** Directional gain =  $10 \log[(10^{G1/20} + 10^{G2/20})^2 / 2] = 7.72\text{dBi} > 6\text{dBi}$  , so the power density limit shall be reduced to  $8-(7.72-6) = 6.28\text{dBm}$ .

### 802.11n (HT40)

| TX chain | Channel | FREQ. (MHz) | PSD (dBm/3kHz) | 10 log (N=2) dB | Total PSD (dBm/3kHz) | Limit (dBm/3kHz) | PASS /FAIL |
|----------|---------|-------------|----------------|-----------------|----------------------|------------------|------------|
| 0        | 151     | 5755        | -4.26          | 3.01            | -1.25                | 6.28             | PASS       |
|          | 159     | 5795        | -2.81          | 3.01            | 0.20                 | 6.28             | PASS       |
| 1        | 151     | 5755        | -3.68          | 3.01            | -0.67                | 6.28             | PASS       |
|          | 159     | 5795        | -1.04          | 3.01            | 1.97                 | 6.28             | PASS       |

**NOTE:** Directional gain =  $10 \log[(10^{G1/20} + 10^{G2/20})^2 / 2] = 7.72\text{dBi} > 6\text{dBi}$  , so the power density limit shall be reduced to  $8-(7.72-6) = 6.28\text{dBm}$ .



## 5.7 CONDUCTED OUT-BAND EMISSION MEASUREMENT

### 5.7.1 LIMITS OF CONDUCTED OUT-BAND EMISSION MEASUREMENT

Below 20dB of the highest emission level of operating band (in 100kHz Resolution Bandwidth).

### 5.7.2 TEST INSTRUMENTS

| DESCRIPTION & MANUFACTURER | MODEL NO. | SERIAL NO. | CALIBRATED DATE | CALIBRATED UNTIL |
|----------------------------|-----------|------------|-----------------|------------------|
| R&S Spectrum Analyzer      | FSP40     | 100037     | Nov. 01, 2012   | Oct. 31, 2013    |

**Note:**

1. The calibration interval of the above test instruments is 12 months and the calibrations are traceable to NML/ROC and NIST/USA.
2. Tested date : Apr. 11, 2013

### 5.7.3 TEST PROCEDURE

#### Measurement Procedure - Reference Level

1. Set the RBW = 100 kHz.
2. Set the VBW  $\geq$  300 kHz.
3. Detector = peak.
4. Sweep time = auto couple.
5. Trace mode = max hold.
6. Allow trace to fully stabilize.
7. Use the peak marker function to determine the maximum power level in any 100 kHz band segment within the fundamental EBW.

#### Measurement Procedure –Unwanted Emission Level

1. Set RBW = 100 kHz.
2. Set VBW  $\geq$  300 kHz.
3. Set span to encompass the spectrum to be examined
4. Detector = peak.
5. Trace Mode = max hold.
6. Sweep = auto couple.

#### 5.7.4 DEVIATION FROM TEST STANDARD

No deviation

#### 5.7.5 TEST SETUP

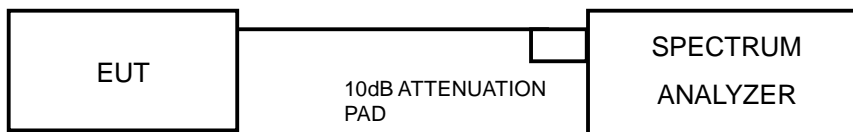

#### 5.7.6 EUT OPERATING CONDITION

Same as Item 4.3.6

#### 5.7.7 TEST RESULTS

The spectrum plots are attached on the following pages. D1 line indicates the highest level, and D2 line indicates the 20dB offset below D1. It shows compliance with the requirement.



A D T

802.11a

### CH 149

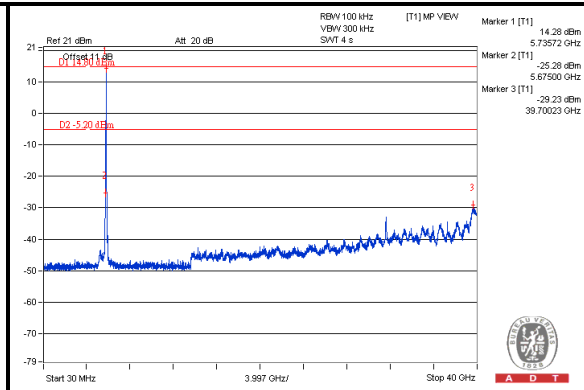
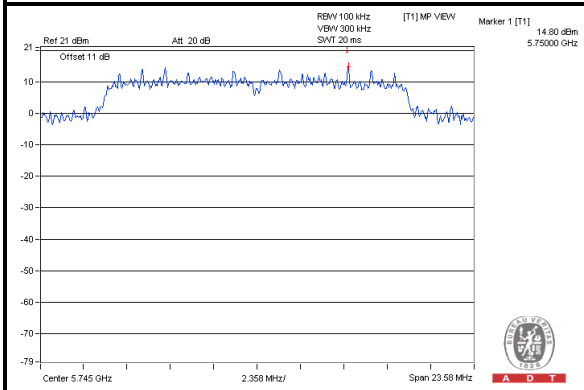

### CH 157

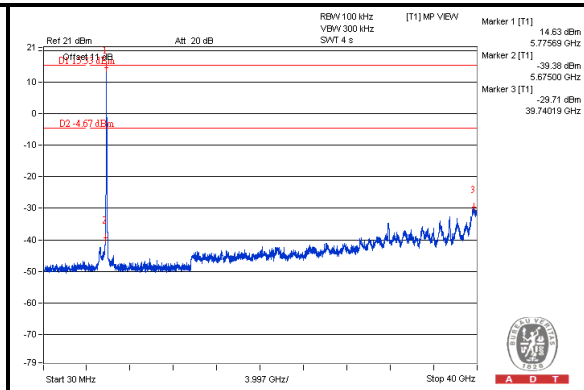
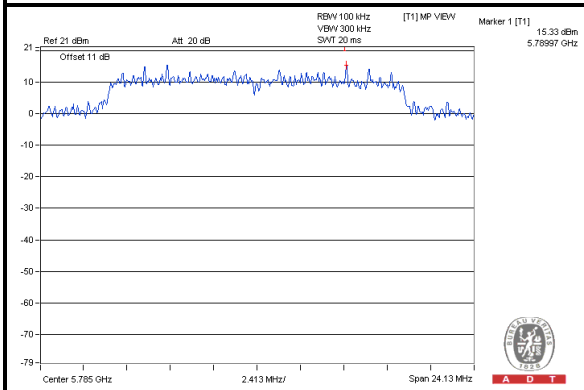

### CH 165

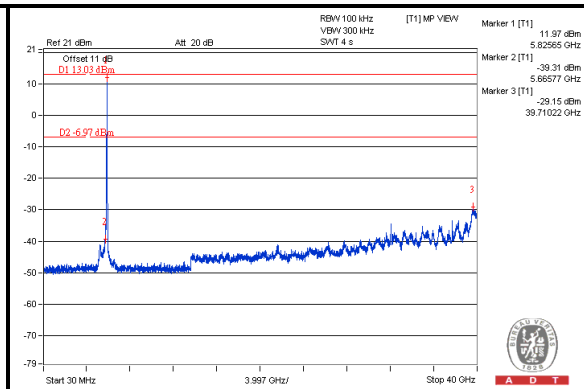
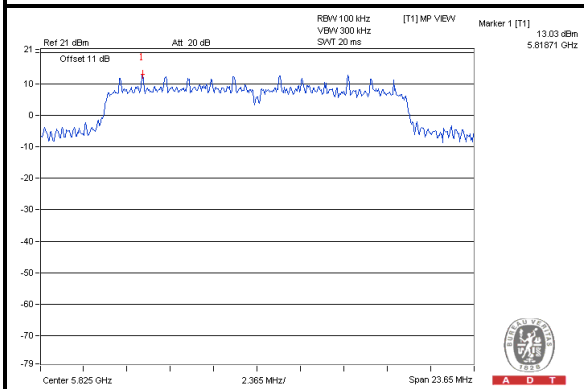



A D T

### 802.11n (HT20):

#### Chain (0)

#### CH 149

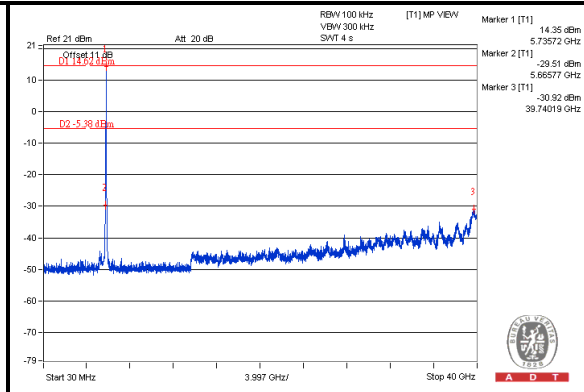
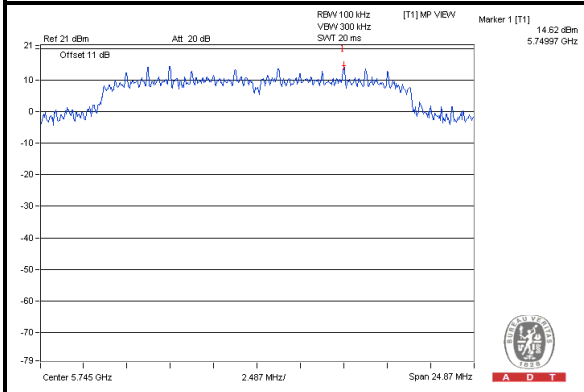

#### CH 157

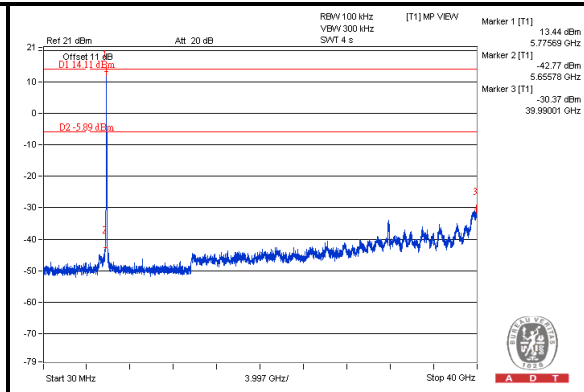
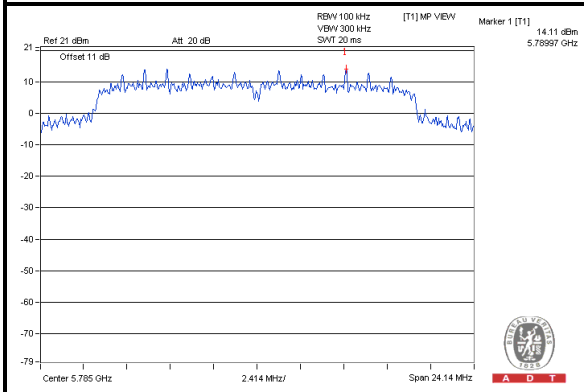

#### CH 165

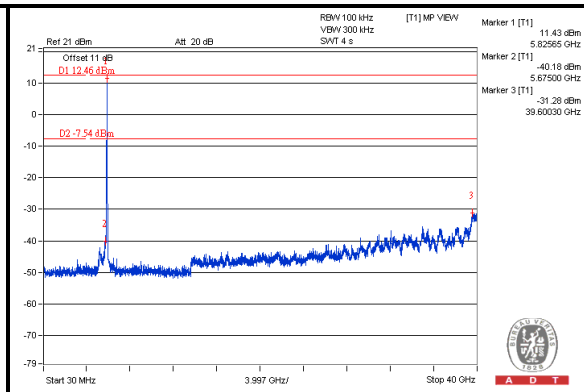
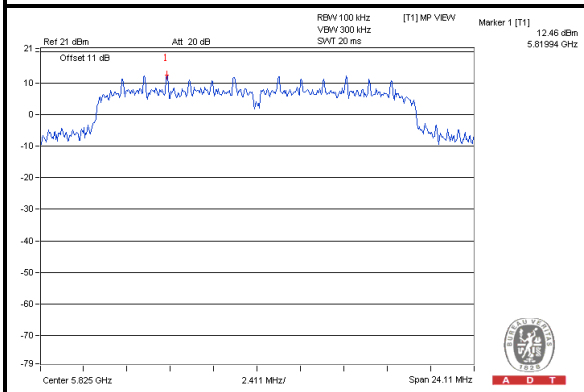



A D T

### Chain (1)

### CH 149

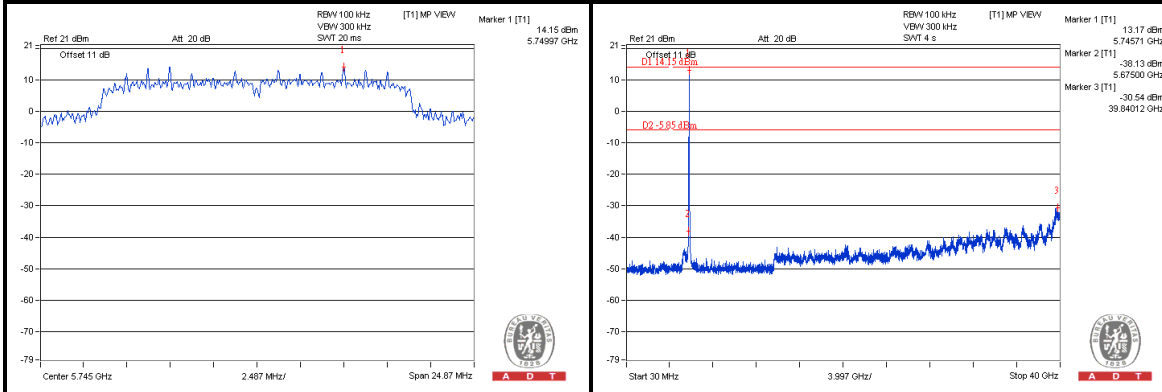

### CH 157

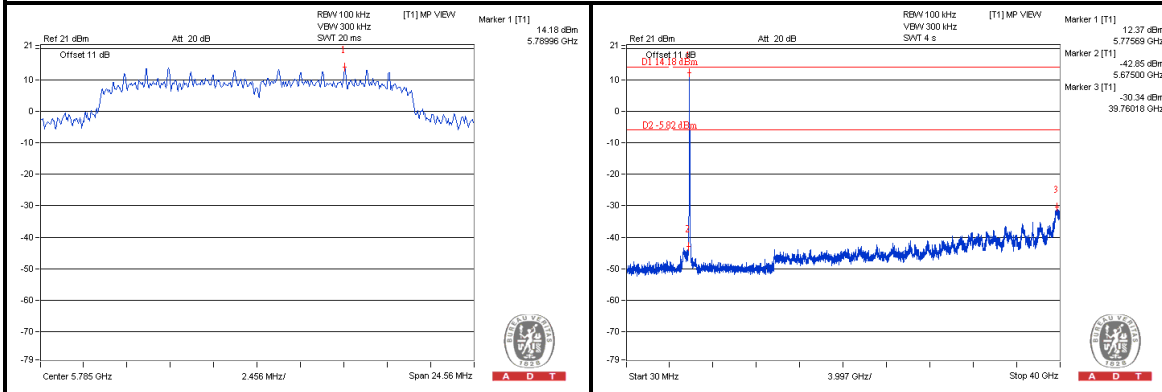

### CH 165

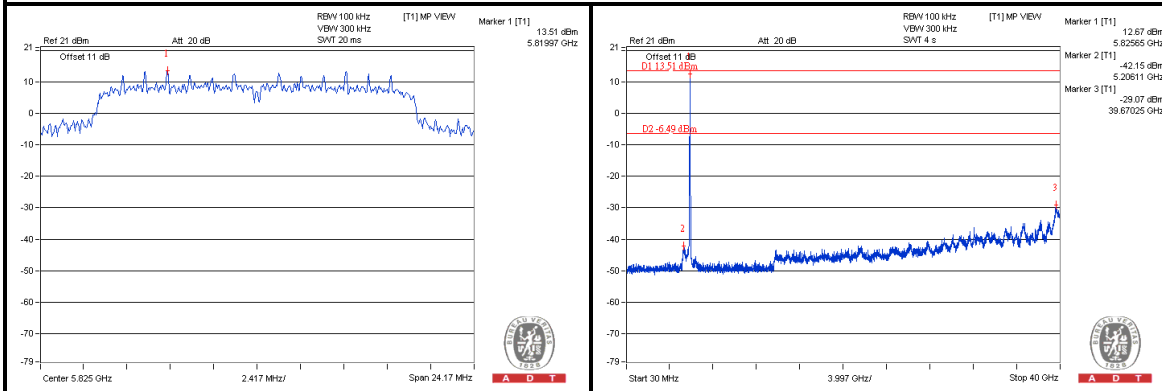



A D T

### 802.11n (HT40):

#### Chain (0)

#### CH 15

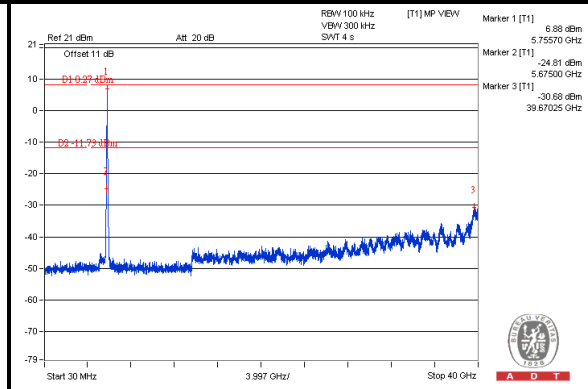
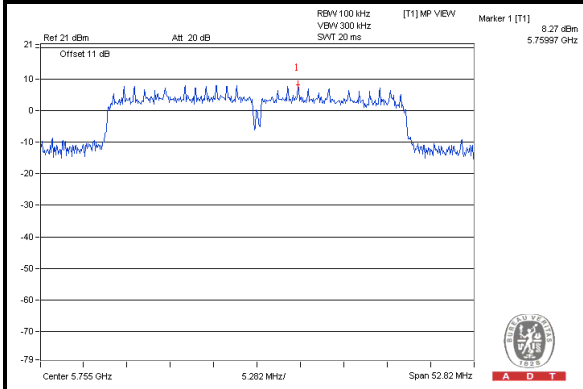

#### CH 159

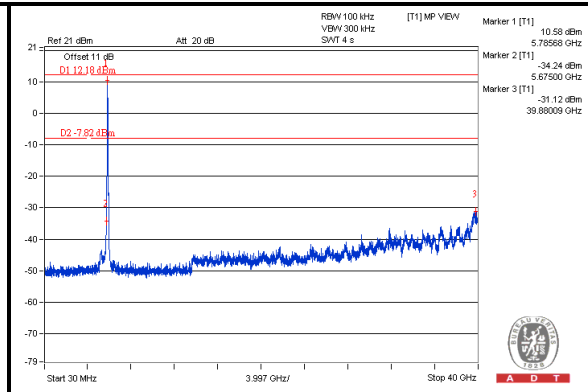
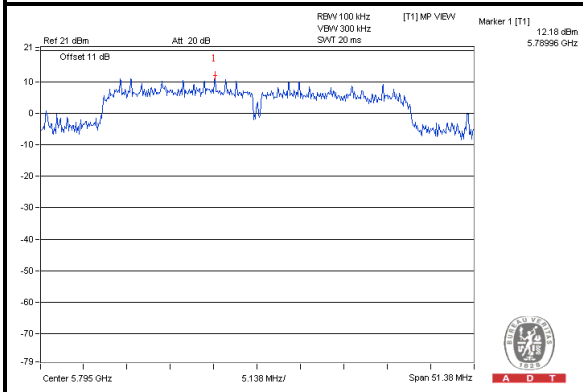



A D T

### Chain (1)

### CH 151

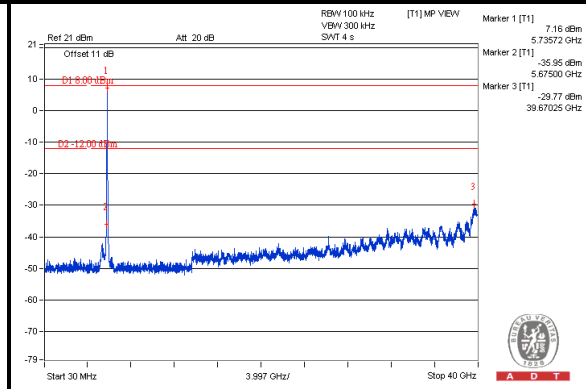
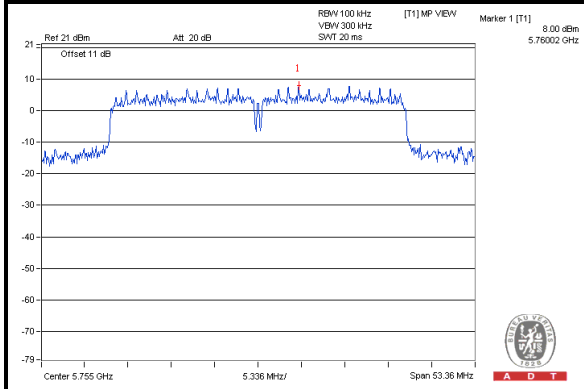

### CH 159

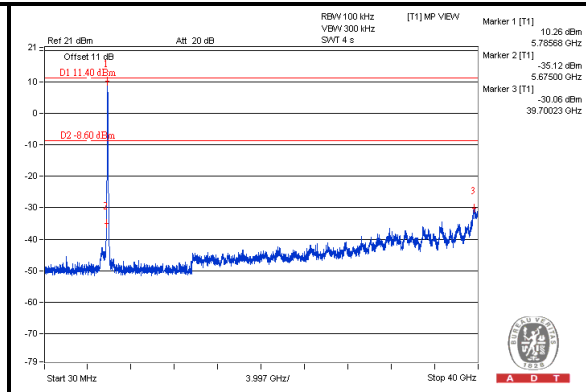
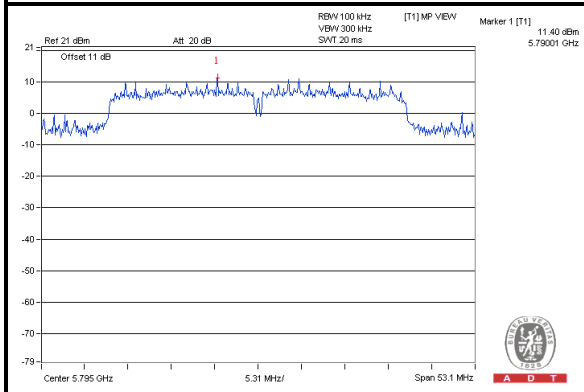



A D T

## 6. PHOTOGRAPHS OF THE TEST CONFIGURATION

Please refer to the attached file (Test Setup Photo).







## 7. INFORMATION ON THE TESTING LABORATORIES

We, Bureau Veritas Consumer Products Services (H.K.) Ltd., Taoyuan Branch, were founded in 1988 to provide our best service in EMC, Radio, Telecom and Safety consultation. Our laboratories are accredited and approved according to ISO/IEC 17025.

If you have any comments, please feel free to contact us at the following:

**Linko EMC/RF Lab:**

Tel: 886-2-26052180

Fax: 886-2-26052943

**Hsin Chu EMC/RF Lab:**

Tel: 886-3-5935343

Fax: 886-3-5935342

**Hwa Ya EMC/RF/Safety/Telecom Lab:**

Tel: 886-3-3183232

Fax: 886-3-3270892

**Email:** [service.adt@tw.bureauveritas.com](mailto:service.adt@tw.bureauveritas.com)

**Web Site:** [www.bureauveritas-adt.com](http://www.bureauveritas-adt.com)

The address and road map of all our labs can be found in our web site also.



A D T

## 8. APPENDIX A - MODIFICATIONS RECORDERS FOR ENGINEERING CHANGES TO THE EUT BY THE LAB

No modifications were made to the EUT by the lab during the test.

--- END ---