



FCC 47 CFR PART 15 SUBPART C

TEST REPORT

For

450Mbps Wireless N Dual Band USB Adapter

Model: TEW-684UB

Trade Name: TRENDnet

Issued to

TRENDnet, Inc.
20675 Manhattan Place, Torrance, CA 90501

Issued by



Compliance Certification Services Inc.
No. 11, Wu-Gong 6th Rd., Wugu Industrial Park,
Taipei Hsien 248, Taiwan (R.O.C.)
<http://www.ccsrf.com>
service@ccsrf.com



Testing Laboratory
1309

Note: This report shall not be reproduced except in full, without the written approval of Compliance Certification Services Inc. This document may be altered or revised by Compliance Certification Services Inc. personnel only, and shall be noted in the revision section of the document.



TABLE OF CONTENTS

1. TEST RESULT CERTIFICATION.....	3
2. EUT DESCRIPTION	4
3. TEST METHODOLOGY	5
3.1 EUT CONFIGURATION	5
3.2 EUT EXERCISE.....	5
3.3 GENERAL TEST PROCEDURES.....	5
3.4 FCC PART 15.205 RESTRICTED BANDS OF OPERATIONS.....	6
3.5 DESCRIPTION OF TEST MODES	7
4. INSTRUMENT CALIBRATION.....	8
4.1 MEASURING INSTRUMENT CALIBRATION	8
4.2 MEASUREMENT EQUIPMENT USED	8
5. FACILITIES AND ACCREDITATIONS	9
5.1 FACILITIES.....	10
5.2 EQUIPMENT.....	10
5.3 TABLE OF ACCREDITATIONS AND LISTINGS.....	11
6. SETUP OF EQUIPMENT UNDER TEST	12
6.1 SETUP CONFIGURATION OF EUT.....	12
6.2 SUPPORT EQUIPMENT	12
7. FCC PART 15.247 REQUIREMENTS.....	13
7.1 6DB BANDWIDTH.....	13
7.2 PEAK POWER.....	40
7.3 AVERAGE POWER	42
7.4 BAND EDGES MEASUREMENT	44
7.5 PEAK POWER SPECTRAL DENSITY.....	53
7.6 SPURIOUS EMISSIONS.....	86
7.7 RADIATED EMISSIONS	117
7.8 POWERLINE CONDUCTED EMISSIONS.....	134
APPENDIX I RADIO FREQUENCY EXPOSURE	137
APPENDIX II PHOTOGRAPHS OF TEST SETUP	140
APPENDIX 1 - PHOTOGRAPHS OF EUT	



1. TEST RESULT CERTIFICATION

Applicant: TRENDnet, Inc.
20675 Manhattan Place, Torrance, CA 90501

Equipment Under Test: 450Mbps Wireless N Dual Band USB Adapter

Trade Name: TRENDnet

Model Number: TEW-684UB

Date of Test: April 6 ~ 18, 2011

APPLICABLE STANDARDS	
STANDARD	TEST RESULT
FCC 47 CFR Part 15 Subpart C	No non-compliance noted
Deviation from Applicable Standard	
N/A	

We hereby certify that:

The above equipment was tested by Compliance Certification Services Inc. The test data, data evaluation, test procedures, and equipment configurations shown in this report were made in accordance with the procedures given in ANSI C63.4: 2003 and the energy emitted by the sample EUT tested as described in this report is in compliance with the requirements of FCC Rules Part 15.207, 15.209, 15.247.

The test results of this report relate only to the tested sample EUT identified in this report.

Approved by:

Reviewed by:

Rex Lai
Section Manager
Compliance Certification Services Inc.

Gina Lo
Section Manager
Compliance Certification Services Inc.



2. EUT DESCRIPTION

Product	450Mbps Wireless N Dual Band USB Adapter
Trade Name	TRENDnet
Model Number	TEW-684UB
Model Discrepancy	N/A
Power Supply	Power from host device via USB Cable
Frequency Range	2412 ~ 2462 MHz
Transmit Power	IEEE 802.11b mode: 18.03 dBm IEEE 802.11g mode: 15.09 dBm IEEE 802.11n HT 20 MHz mode: 14.89 dBm IEEE 802.11n HT 40 MHz mode: 14.76 dBm
Modulation Technique	IEEE 802.11b mode: DSSS IEEE 802.11g mode: OFDM IEEE 802.11n HT 20 MHz mode: OFDM IEEE 802.11n HT 40 MHz mode: OFDM
Number of Channels	IEEE 802.11b/g mode: 11 Channels IEEE 802.11n HT 20 MHz mode: 11 Channels IEEE 802.11n HT 40 MHz mode: 7 Channels
Antenna Specification	PCB Antenna / Gain: 2 dBi

Remark:

1. The sample selected for test was production product and was provided by manufacturer.
2. This submittal(s) (test report) is intended for FCC ID: XU8TEW684UB filing to comply with Section 15.207, 15.209 and 15.247 of the FCC Part 15, Subpart C Rules.



3. TEST METHODOLOGY

The tests documented in this report were performed in accordance with ANSI C63.4 and FCC CFR 47 2.1046, 2.1047, 2.1049, 2.1051, 2.1053, 2.1055, 2.1057, 15.207, 15.209 and 15.247.

3.1 EUT CONFIGURATION

The EUT configuration for testing is installed on RF field strength measurement to meet the Commissions requirement and operating in a manner that intends to maximize its emission characteristics in a continuous normal application.

3.2 EUT EXERCISE

The EUT was operated in the engineering mode to fix the TX frequency that was for the purpose of the measurements.

According to its specifications, the EUT must comply with the requirements of the Section 15.207, 15.209 and 15.247 under the FCC Rules Part 15 Subpart C.

3.3 GENERAL TEST PROCEDURES

Conducted Emissions

The EUT is placed on the turntable, which is 0.8 m above ground plane. According to the requirements in Section 13.1.4.1 of ANSI C63.4 Conducted emissions from the EUT measured in the frequency range between 0.15 MHz and 30MHz using CISPR Quasi-peak and average detector modes.

Radiated Emissions

The EUT is placed on a turn table, which is 0.8 m above ground plane. The turntable shall rotate 360 degrees to determine the position of maximum emission level. EUT is set 3m away from the receiving antenna, which varied from 1m to 4m to find out the highest emission. And also, each emission was to be maximized by changing the polarization of receiving antenna both horizontal and vertical. In order to find out the maximum emissions, exploratory radiated emission measurements were made according to the requirements in Section 13.1.4.1 of ANSI C63.4.



3.4 FCC PART 15.205 RESTRICTED BANDS OF OPERATIONS

(a) Except as shown in paragraph (d) of this section, only spurious emissions are permitted in any of the frequency bands listed below:

MHz	MHz	MHz	GHz
0.090 - 0.110	16.42 - 16.423	399.9 - 410	4.5 - 5.15
¹ 0.495 - 0.505	16.69475 - 16.69525	608 - 614	5.35 - 5.46
2.1735 - 2.1905	16.80425 - 16.80475	960 - 1240	7.25 - 7.75
4.125 - 4.128	25.5 - 25.67	1300 - 1427	8.025 - 8.5
4.17725 - 4.17775	37.5 - 38.25	1435 - 1626.5	9.0 - 9.2
4.20725 - 4.20775	73 - 74.6	1645.5 - 1646.5	9.3 - 9.5
6.215 - 6.218	74.8 - 75.2	1660 - 1710	10.6 - 12.7
6.26775 - 6.26825	108 - 121.94	1718.8 - 1722.2	13.25 - 13.4
6.31175 - 6.31225	123 - 138	2200 - 2300	14.47 - 14.5
8.291 - 8.294	149.9 - 150.05	2310 - 2390	15.35 - 16.2
8.362 - 8.366	156.52475 -	2483.5 - 2500	17.7 - 21.4
8.37625 - 8.38675	156.52525	2655 - 2900	22.01 - 23.12
8.41425 - 8.41475	156.7 - 156.9	3260 - 3267	23.6 - 24.0
12.29 - 12.293	162.0125 - 167.17	3332 - 3339	31.2 - 31.8
12.51975 - 12.52025	167.72 - 173.2	3345.8 - 3358	36.43 - 36.5
12.57675 - 12.57725	240 - 285	3600 - 4400	(²)
13.36 - 13.41	322 - 335.4		

¹ Until February 1, 1999, this restricted band shall be 0.490-0.510 MHz.

² Above 38.6

(b) Except as provided in paragraphs (d) and (e), the field strength of emissions appearing within these frequency bands shall not exceed the limits shown in Section 15.209. At frequencies equal to or less than 1000 MHz, compliance with the limits in Section 15.209 shall be demonstrated using measurement instrumentation employing a CISPR quasi-peak detector. Above 1000 MHz, compliance with the emission limits in Section 15.209 shall be demonstrated based on the average value of the measured emissions. The provisions in Section 15.35 apply to these measurements.



3.5 DESCRIPTION OF TEST MODES

The EUT (model: TEW-684UB) had been tested under operating condition.

The EUT is a 3x3 configuration spatial MIMO (3Tx & 3Rx) without beam forming function that operate in triple TX chains and triple RX chains. The 3x3 configuration is implemented with three outside TX & RX chains (Chain 0, Chain 1 and Chain 2).

Software used to control the EUT for staying in continuous transmitting mode was programmed.

After verification, all tests were carried out with the worst case test modes as shown below except radiated spurious emission below 1GHz and power line conducted emissions below 30MHz, which worst case was in normal link mode only.

IEEE 802.11b mode:

Channel Low (2412MHz), Channel Mid (2442MHz) and Channel High (2462MHz) with 1Mbps data rate were chosen for full testing.

IEEE 802.11g mode:

Channel Low (2412MHz), Channel Mid (2442MHz) and Channel High (2462MHz) with 6Mbps data rate were chosen for full testing.

IEEE 802.11n HT 20 MHz mode:

Channel Low (2412MHz), Channel Mid (2442MHz) and Channel High (2462MHz) with 6.5Mbps data rate were chosen for full testing.

IEEE 802.11n HT 40 MHz mode:

Channel Low (2422MHz), Channel Mid (2442MHz) and Channel High (2452MHz) with 13.5Mbps data rate were chosen for full testing.



4. INSTRUMENT CALIBRATION

4.1 MEASURING INSTRUMENT CALIBRATION

The measuring equipment, which was utilized in performing the tests documented herein, has been calibrated in accordance with the manufacturer's recommendations for utilizing calibration equipment, which is traceable to recognized national standards.

4.2 MEASUREMENT EQUIPMENT USED

Equipment Used for Emissions Measurement

Remark: Each piece of equipment is scheduled for calibration once a year and Loop Antenna is scheduled for calibration once three years.

Conducted Emissions Test Site				
Name of Equipment	Manufacturer	Model	Serial Number	Calibration Due
Spectrum Analyzer	Agilent	E4446A	MY43360131	03/02/2012
Power Meter	Anritsu	ML2495A	1012009	03/27/2012
Power Sensor	Anritsu	MA2411B	0917072	03/08/2012

Wugu 966 Chamber A				
Name of Equipment	Manufacturer	Model	Serial Number	Calibration Due
Spectrum Analyzer	Agilent	E4446A	US42510252	11/03/2011
EMI Test Receiver	R&S	ESCI	100064	02/03/2012
Pre-Amplifier	Mini-Circuits	ZFL-1000LN	SF350700823	01/12/2012
Pre-Amplifier	MITEQ	AFS44-00102650-42-10P-44	1415367	11/19/2011
Bilog Antenna	Sunol Sciences	JB3	A030105	10/06/2011
Horn Antenna	EMCO	3117	00055165	01/12/2012
Loop Antenna	EMCO	6502	8905/2356	06/10/2013
Turn Table	CCS	CC-T-1F	N/A	N.C.R
Antenna Tower	CCS	CC-A-1F	N/A	N.C.R
Controller	CCS	CC-C-1F	N/A	N.C.R
Site NSA	CCS	N/A	N/A	12/26/2011
Test S/W	EZ-EMC (CCS-3A1RE)			

Conducted Emission room # A				
Name of Equipment	Manufacturer	Model	Serial Number	Calibration Due
EMI Test Receiver	R&S	ESHS10	843743/015	03/24/2012
LISN	SCHWARZBECK	NSLK 8127	8127-541	12/18/2011
LISN	SCHAFFNER	NNB 41	03/10013	N.C.R.
Test S/W	CCS-3A1-CE			



4.3 MEASUREMENT UNCERTAINTY

PARAMETER	UNCERTAINTY
Powerline Conducted Emission	+/- 1.6202
3M Semi Anechoic Chamber / 30M~200M	+/- 4.0606
3M Semi Anechoic Chamber / 200M~1000M	+/- 3.9979
3M Semi Anechoic Chamber / 1G~8G	+/- 2.5790
3M Semi Anechoic Chamber / 8G~18G	+/- 2.5928
3M Semi Anechoic Chamber / 18G~26G	+/- 2.7212
3M Semi Anechoic Chamber / 26G~40G	+/- 2.9520

Remark: This uncertainty represents an expanded uncertainty expressed at approximately the 95% confidence level using a coverage factor of $k=2$.



5. FACILITIES AND ACCREDITATIONS

5.1 FACILITIES

All measurement facilities used to collect the measurement data are located at

No.199, Chunghsen Road, Hsintien City, Taipei Hsien, Taiwan, R.O.C.
Tel: 886-2-2217-0894 / Fax: 886-2-2217-1029

No.11, Wugong 6th Rd., Wugu Industrial Park, Taipei Hsien 248, Taiwan
Tel: 886-2-2299-9720 / Fax: 886-2-2298-4045

No.81-1, Lane 210, Bade 2nd Rd., Luchu Hsiang, Taoyuan Hsien 338, Taiwan
Tel: 886-3-324-0332 / Fax: 886-3-324-5235

The sites are constructed in conformance with the requirements of ANSI C63.7, ANSI C63.4 and CISPR Publication 22.

5.2 EQUIPMENT

Radiated emissions are measured with one or more of the following types of linearly polarized antennas: tuned dipole, biconical, log periodic, bi-log, and/or ridged waveguide, horn. Spectrum analyzers with pre-selectors and quasi-peak detectors are used to perform radiated measurements.



Conducted emissions are measured with Line Impedance Stabilization Networks and EMI Test Receivers.

Calibrated wideband preamplifiers, coaxial cables, and coaxial attenuators are also used for making measurements.

All receiving equipment conforms to CISPR Publication 16-1, "Radio Interference Measuring Apparatus and Measurement Methods."



5.3 TABLE OF ACCREDITATIONS AND LISTINGS

Country	Agency	Scope of Accreditation	Logo
USA	FCC	3M Semi Anechoic Chamber (FCC MRA: TW1039) to perform FCC Part 15 measurements	 FCC MRA: TW1039
Taiwan	TAF	LP0002, RTTE01, FCC Method-47 CFR Part 15 Subpart C, D, E, RSS-210, RSS-310 IDA TS SRD, AS/NZS 4268, AS/NZS 4771, TS 12.1 & 12.2, ETSI EN 300 440-1, ETSI EN 300 440-2, ETSI EN 300 328, ETSI EN 300 220-1, ETSI EN 300 220-2, ETSI EN 301 893, ETSI EN 301 489-1/3/7/17 FCC OET Bulletin 65 + Supplement C, EN 50360, EN 50361, EN 50371, RSS 102, EN 50383, EN 50385, EN 50392, IEC 62209, CNS 14958-1, CNS 14959 FCC Method -47 CFR Part 15 Subpart B IEC / EN 61000-3-2, IEC / EN 61000-3-3, IEC / EN 61000-4-2/3/4/5/6/8/11	
Canada	Industry Canada	3M Semi Anechoic Chamber (IC 2324G-1 / IC 2324G-2) to perform	 IC 2324G-1 IC 2324G-2

* No part of this report may be used to claim or imply product endorsement by A2LA or any agency of the US Government.



6. SETUP OF EQUIPMENT UNDER TEST

6.1 SETUP CONFIGURATION OF EUT

See test photographs attached in Appendix II for the actual connections between EUT and support equipment.

SUPPORT EQUIPMENT

No	Equipment	Brand	Model	Series No.	FCC ID	Data Cable	Power Cord
1	Notebook PC	HP	dv6-1332TX	CNF9491GLJ	PD9112BNHU	N/A	AC I/P: Unshielded, 1.8m DC O/P: Unshielded, 1.8m with a core
2	Notebook PC	DELL	PP19L	GK102 A00	QDS-BRCM1021	N/A	AC I/P: Unshielded, 1.8m DC O/P: Unshielded, 1.8m with a core
3	LCD Monitor	DELL	3008WFP	CN-0XK290-71618-846-169L	FCC DoC	Unshielded, 1.8m	shielded, 1.8m
4	USB Mouse	DELL	MO56UO	408031121	FCC DoC	Shielded, 1.8m	N/A
5	USB 2.0 External HDD	TeraSyS	F12-UF(COMBO)	A0100215-42O014	FCC DoC	Shielded, 1.8m	N/A
6	Wireless Pre-N Router (MIMO)	BELKIN	F5D8230-4	N/A	SA3-AGN0901AP 0100	N/A	AC I/P: Unshielded, 1.8m DC O/P: Unshielded, 1.8m with a core

Remark:

1. All the equipment/cables were placed in the worst-case configuration to maximize the emission during the test.
2. Grounding was established in accordance with the manufacturer's requirements and conditions for the intended use.



7. FCC PART 15.247 REQUIREMENTS

7.1 6DB BANDWIDTH

LIMIT

According to §15.247(a)(2), systems using digital modulation techniques may operate in the 902 - 928 MHz, 2400 - 2483.5 MHz, and 5725 - 5850 MHz bands. The minimum 6dB bandwidth shall be at least 500 kHz.

Test Configuration

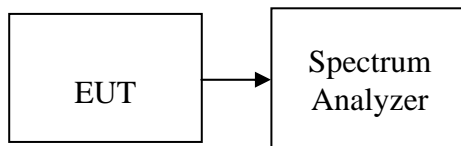

TEST PROCEDURE

1. Place the EUT on the table and set it in the transmitting mode.
2. Remove the antenna from the EUT and then connect a low loss RF cable from the antenna port to the spectrum analyzer.
3. Set the spectrum analyzer as RBW = 100 kHz, VBW = 300kHz, Sweep = auto.
4. Mark the peak frequency and -6dB (upper and lower) frequency.
5. Repeat until all the rest channels are investigated.

TEST RESULTS

No non-compliance noted



Test Data

Test mode: IEEE 802.11b mode

Channel	Frequency (MHz)	Bandwidth (MHz)	Limit (kHz)	Result
Low	2412	12.25	>500	PASS
Mid	2442	12.25		PASS
High	2462	12.25		PASS

Test mode: IEEE 802.11g mode

Channel	Frequency (MHz)	Bandwidth (MHz)	Limit (kHz)	Result
Low	2412	16.75	>500	PASS
Mid	2442	16.75		PASS
High	2462	16.75		PASS

**Test mode: IEEE 802.11n HT 20 MHz mode / Chain 0**

Channel	Frequency (MHz)	Bandwidth (MHz)	Limit (kHz)	Result
Low	2412	17.9167	>500	PASS
Mid	2442	17.9167		PASS
High	2462	17.8334		PASS

Test mode: IEEE 802.11n HT 20 MHz mode / Chain 1

Channel	Frequency (MHz)	Bandwidth (MHz)	Limit (kHz)	Result
Low	2412	17.75	>500	PASS
Mid	2442	17.75		PASS
High	2462	17.75		PASS

Test mode: IEEE 802.11n HT 20 MHz mode / Chain 2

Channel	Frequency (MHz)	Bandwidth (MHz)	Limit (kHz)	Result
Low	2412	17.8334	>500	PASS
Mid	2442	17.8334		PASS
High	2462	17.8334		PASS

Test mode: IEEE 802.11n HT 40 MHz mode / Chain 0

Channel	Frequency (MHz)	Bandwidth (MHz)	Limit (kHz)	Result
Low	2422	36.5	>500	PASS
Mid	2442	36.5		PASS
High	2452	36.5		PASS

Test mode: IEEE 802.11n HT 40 MHz mode / Chain 1

Channel	Frequency (MHz)	Bandwidth (MHz)	Limit (kHz)	Result
Low	2422	36.5	>500	PASS
Mid	2442	36.5		PASS
High	2452	36.5		PASS

Test mode: IEEE 802.11n HT 40 MHz mode / Chain 2

Channel	Frequency (MHz)	Bandwidth (MHz)	Limit (kHz)	Result
Low	2422	36.5	>500	PASS
Mid	2442	36.5		PASS
High	2452	36.5		PASS



Test Plot

IEEE 802.11b mode

6dB Bandwidth (CH Low)

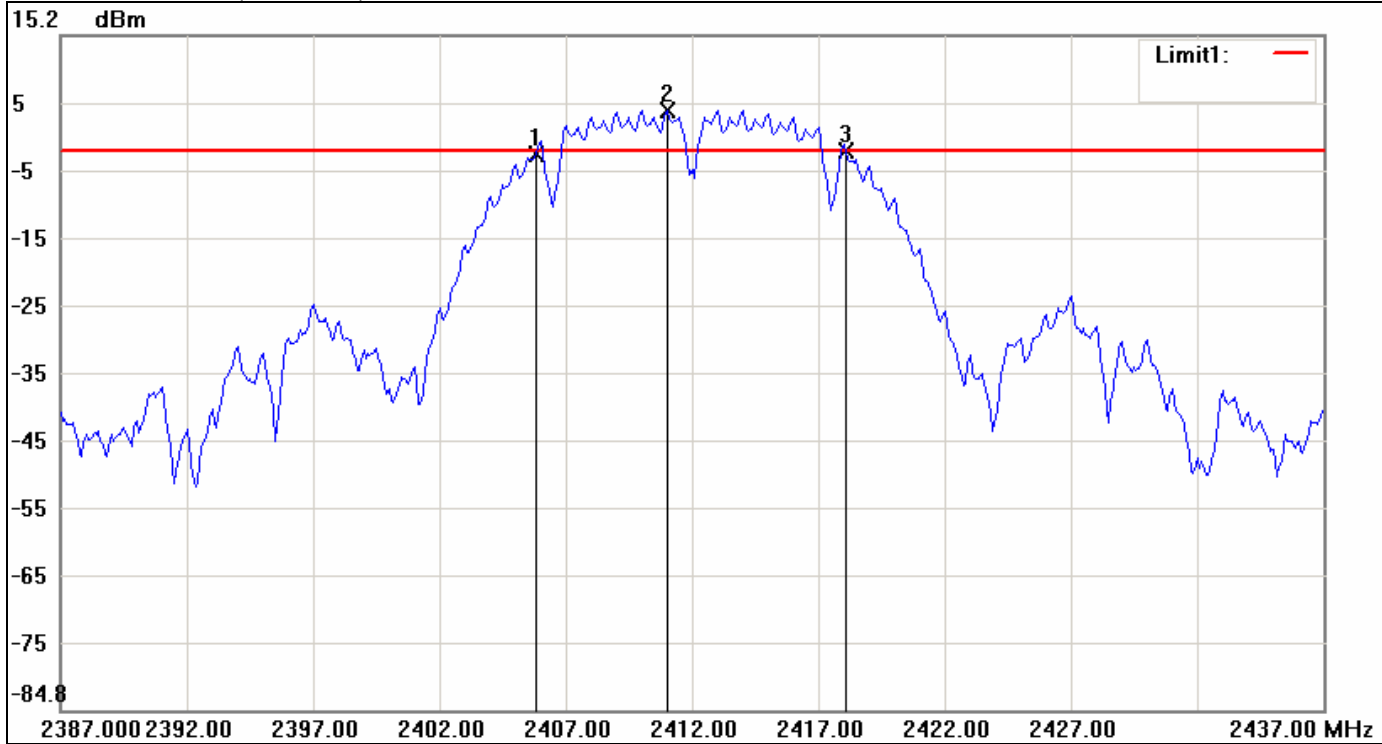

No.	Frequency(MHz)	Level(dBm)	Limit(dBm)	Margin(dBm)
1	2405.8333	-2.38	-1.86	-0.52
2	2411.0000	4.14	-1.86	6.00
3	2418.0833	-1.98	-1.86	-0.12

No.		Δ Frequency(MHz)	Δ Level(dB)
1	mk3-mk1	12.25	0.4



6dB Bandwidth (CH Mid)

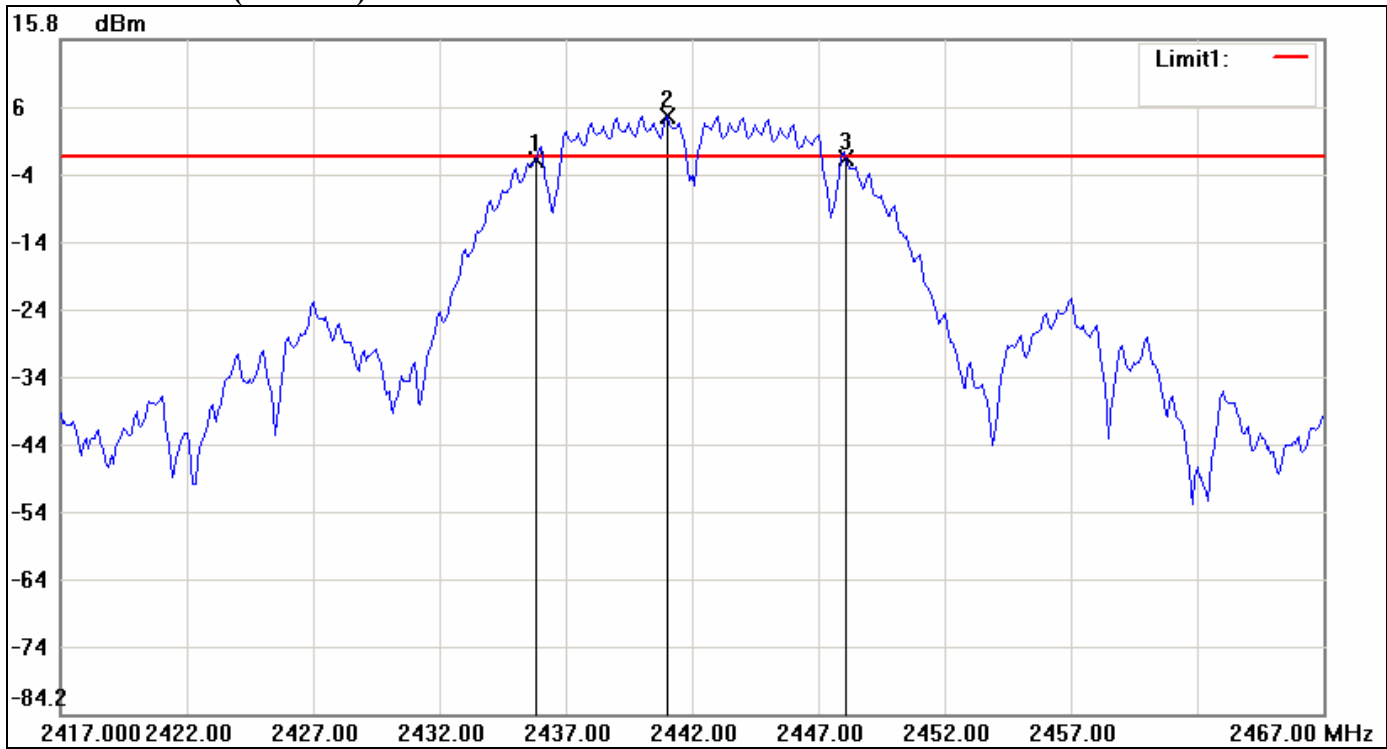

No.	Frequency(MHz)	Level(dBm)	Limit(dBm)	Margin(dBm)
1	2435.8333	-2.09	-1.55	-0.54
2	2441.0000	4.45	-1.55	6.00
3	2448.0833	-1.88	-1.55	-0.33

No.		Δ Frequency(MHz)	Δ Level(dB)
1	mk3-mk1	12.25	0.21



6dB Bandwidth (CH High)

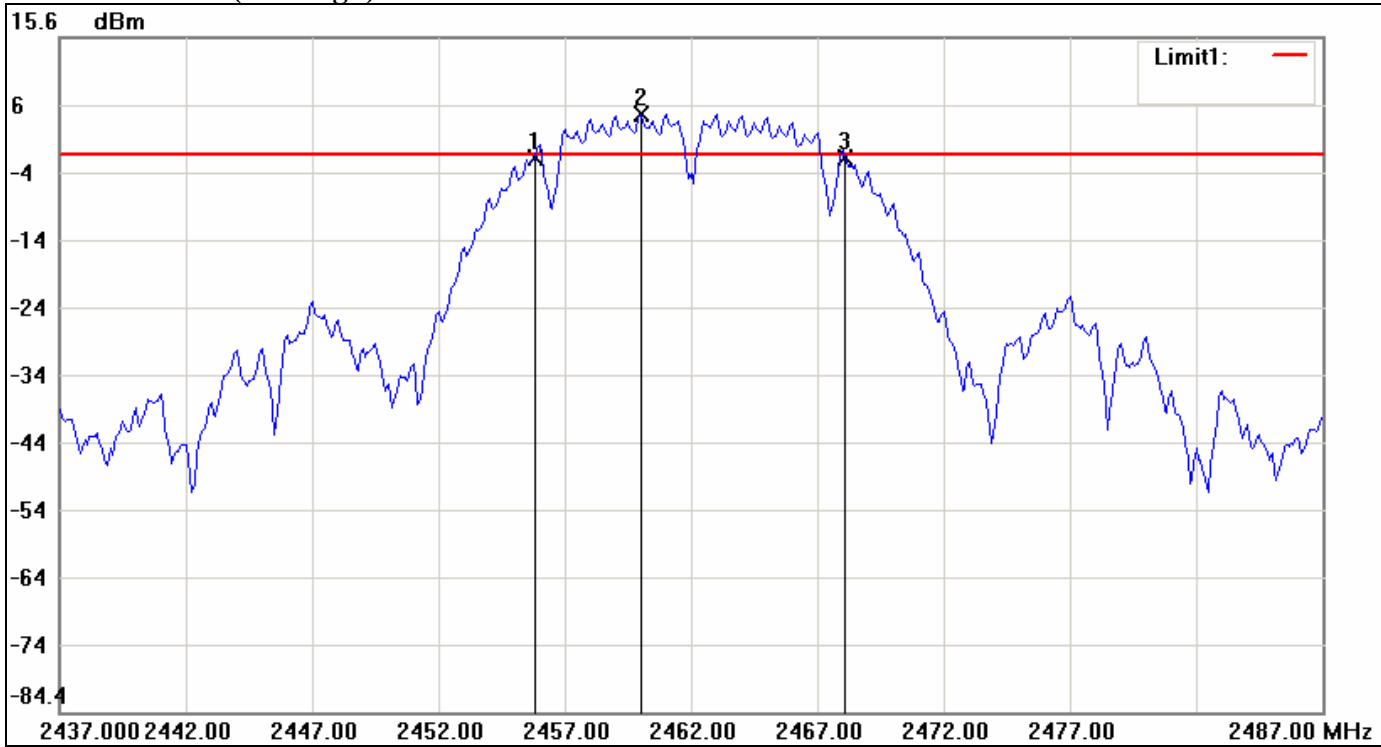

No.	Frequency(MHz)	Level(dBm)	Limit(dBm)	Margin(dBm)
1	2455.8333	-2.17	-1.68	-0.49
2	2460.0000	4.32	-1.68	6.00
3	2468.0833	-2.12	-1.68	-0.44

No.		Δ Frequency(MHz)	Δ Level(dB)
1	mk3-mk1	12.25	0.05



IEEE 802.11g mode

6dB Bandwidth (CH Low)

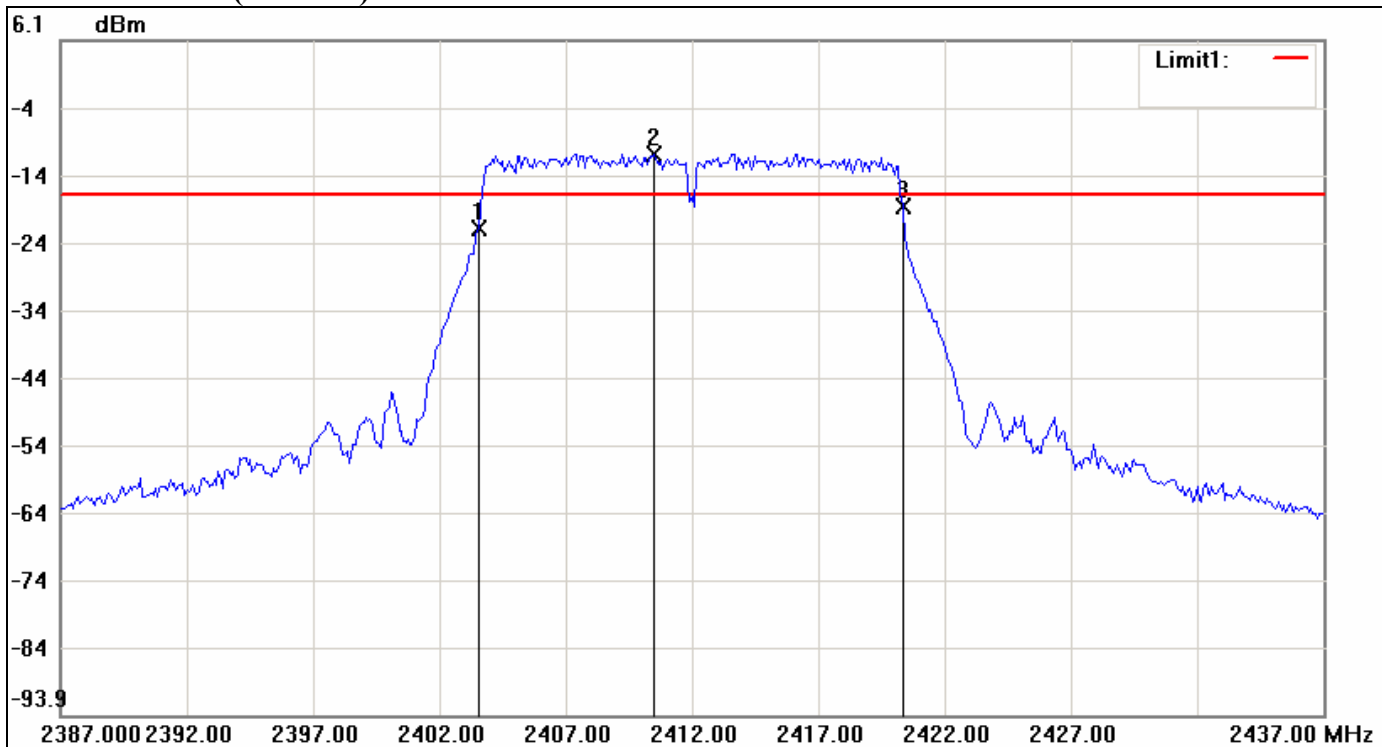

No.	Frequency(MHz)	Level(dBm)	Limit(dBm)	Margin(dBm)
1	2403.5833	-21.88	-16.72	-5.16
2	2410.5000	-10.72	-16.72	6.00
3	2420.3333	-18.66	-16.72	-1.94

No.		Δ Frequency(MHz)	Δ Level(dB)
1	mk3-mk1	16.75	3.22



6dB Bandwidth (CH Mid)

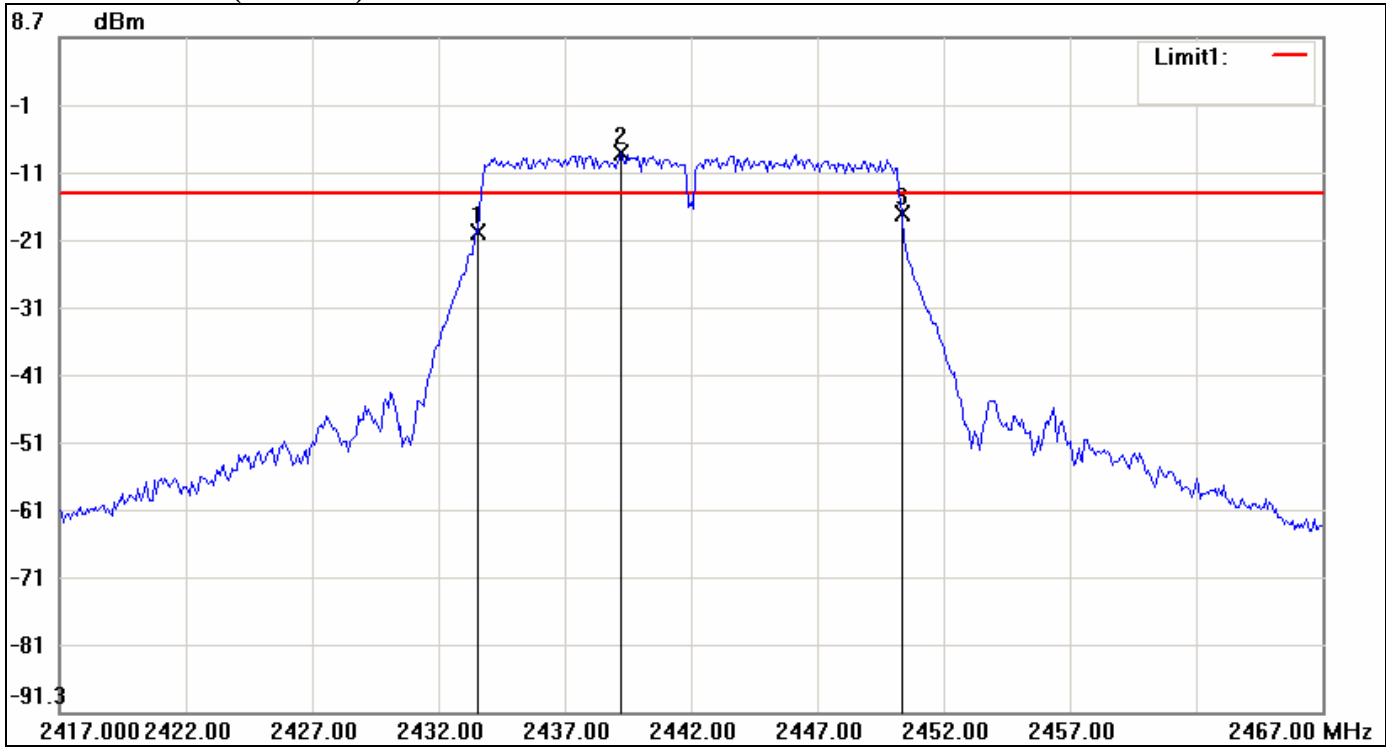

No.	Frequency(MHz)	Level(dBm)	Limit(dBm)	Margin(dBm)
1	2433.5833	-20.21	-14.53	-5.68
2	2439.2500	-8.53	-14.53	6.00
3	2450.3333	-17.46	-14.53	-2.93

No.		Δ Frequency(MHz)	Δ Level(dB)
1	mk3-mk1	16.75	2.75



6dB Bandwidth (CH High)

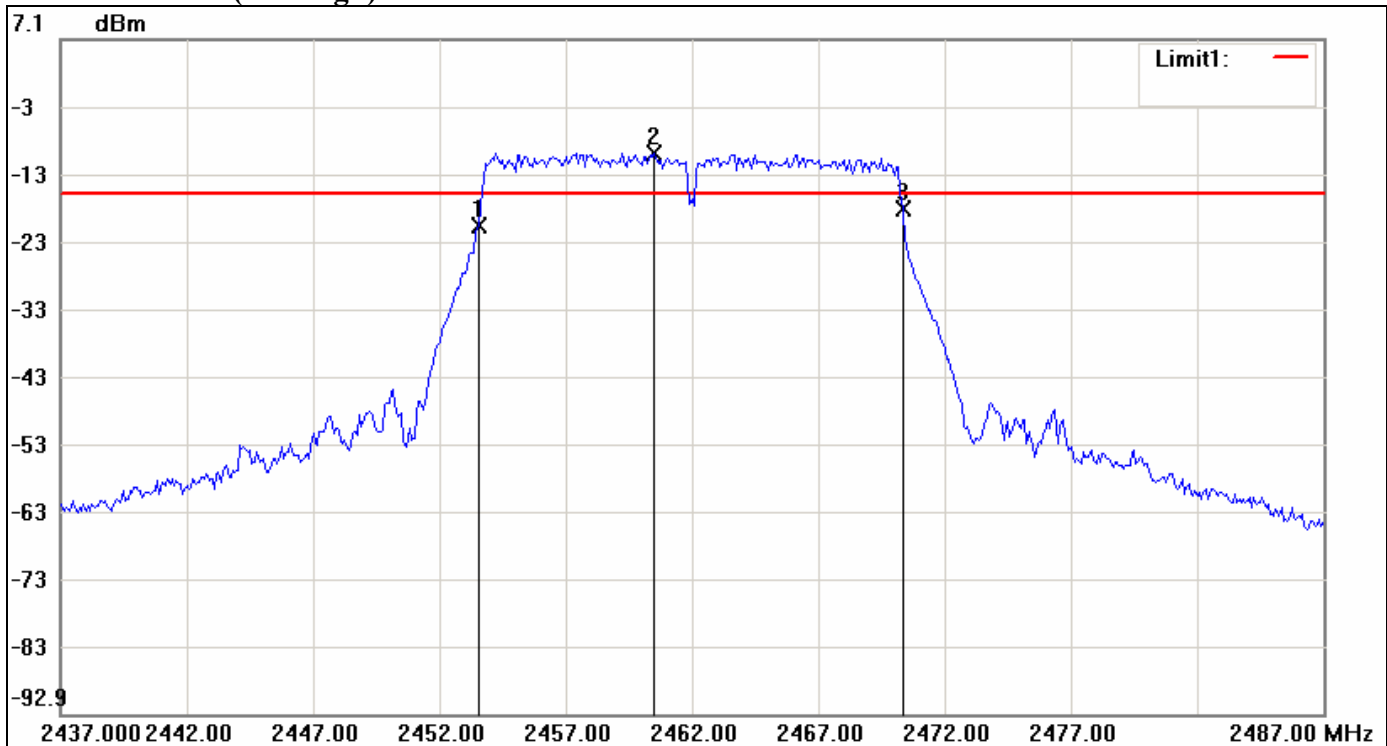

No.	Frequency(MHz)	Level(dBm)	Limit(dBm)	Margin(dBm)
1	2453.5833	-20.54	-15.76	-4.78
2	2460.5000	-9.76	-15.76	6.00
3	2470.3333	-18.13	-15.76	-2.37

No.		Δ Frequency(MHz)	Δ Level(dB)
1	mk3-mk1	16.75	2.41



IEEE 802.11n HT 20 MHz mode / Chain 0

6dB Bandwidth (CH Low)

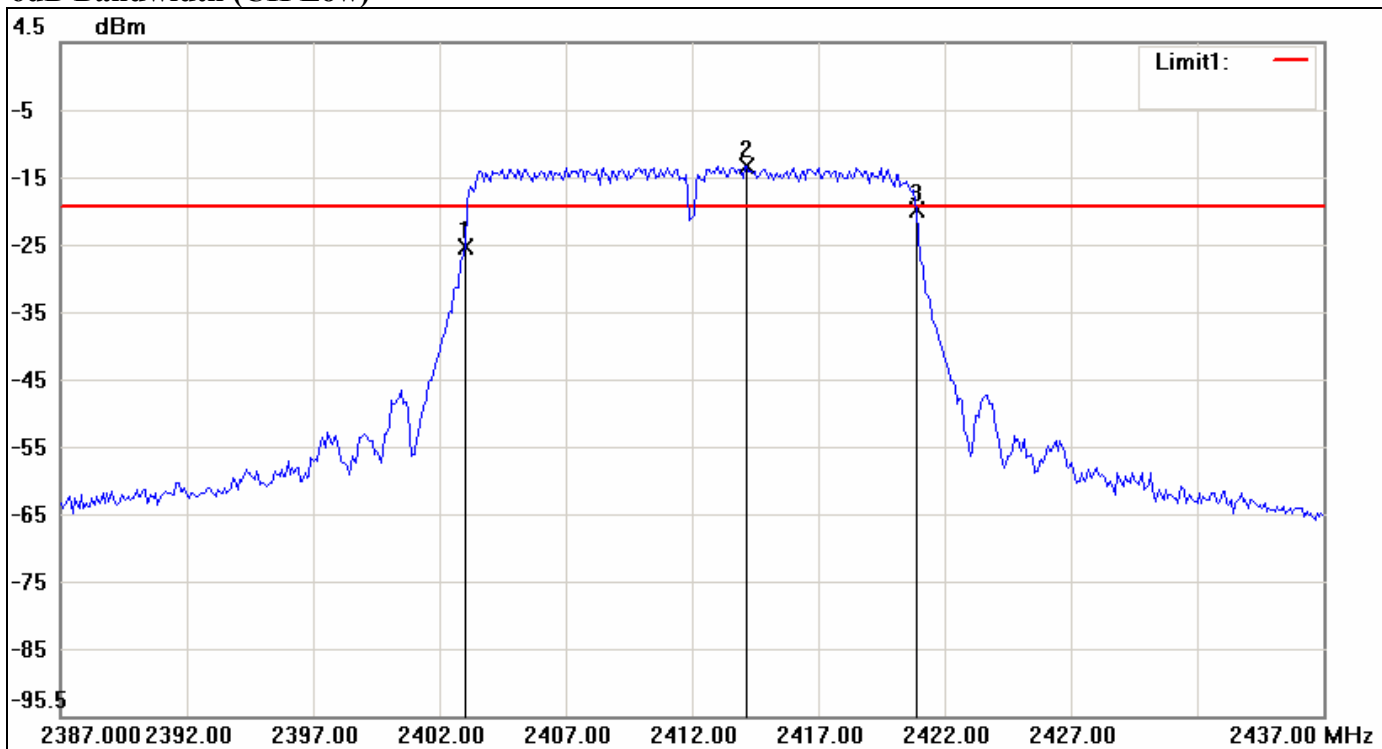

No.	Frequency(MHz)	Level(dBm)	Limit(dBm)	Margin(dBm)
1	2403.0000	-25.93	-19.80	-6.13
2	2414.1667	-13.80	-19.80	6.00
3	2420.9167	-20.38	-19.80	-0.58

No.		Δ Frequency(MHz)	Δ Level(dB)
1	mk3-mk1	17.9167	5.55



6dB Bandwidth (CH Mid)

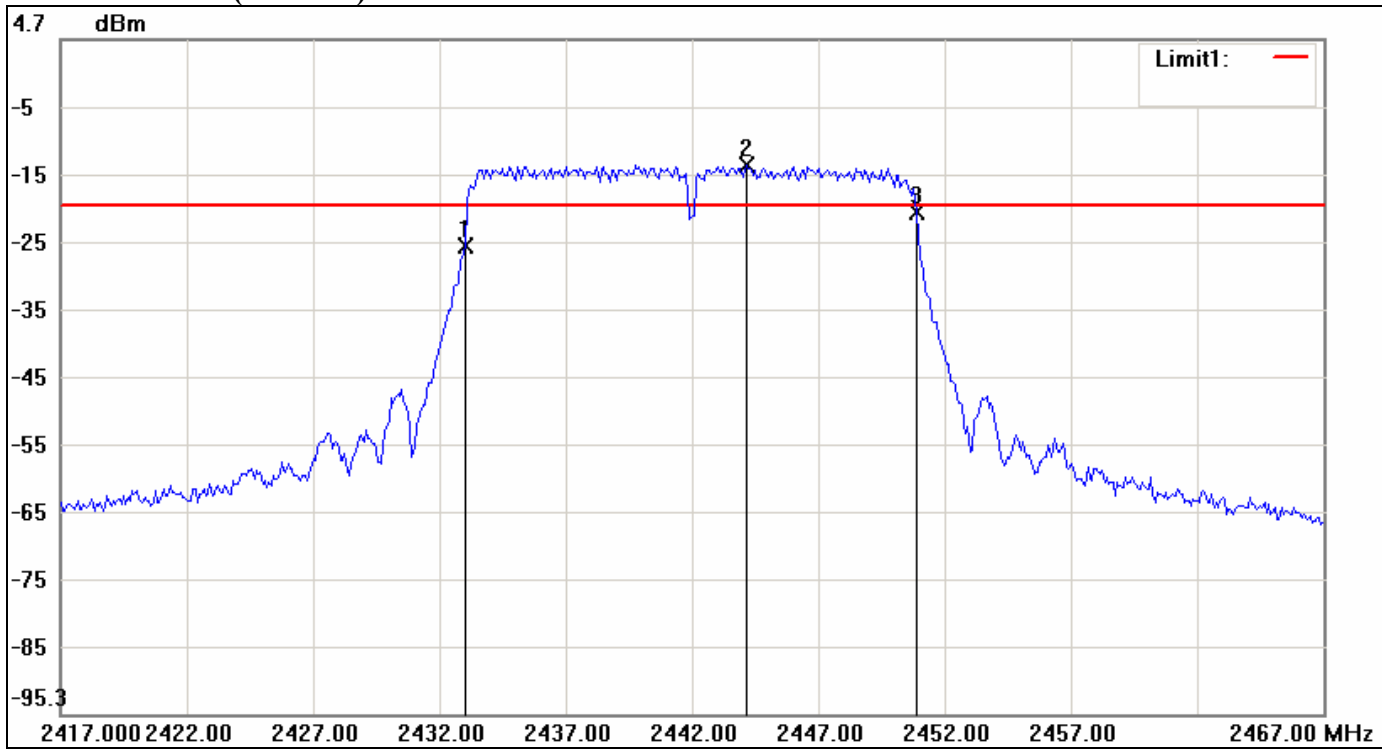

No.	Frequency(MHz)	Level(dBm)	Limit(dBm)	Margin(dBm)
1	2433.0000	-25.87	-19.83	-6.04
2	2444.1667	-13.83	-19.83	6.00
3	2450.9167	-20.77	-19.83	-0.94

No.		Δ Frequency(MHz)	Δ Level(dB)
1	mk3-mk1	17.9167	5.1



6dB Bandwidth (CH High)

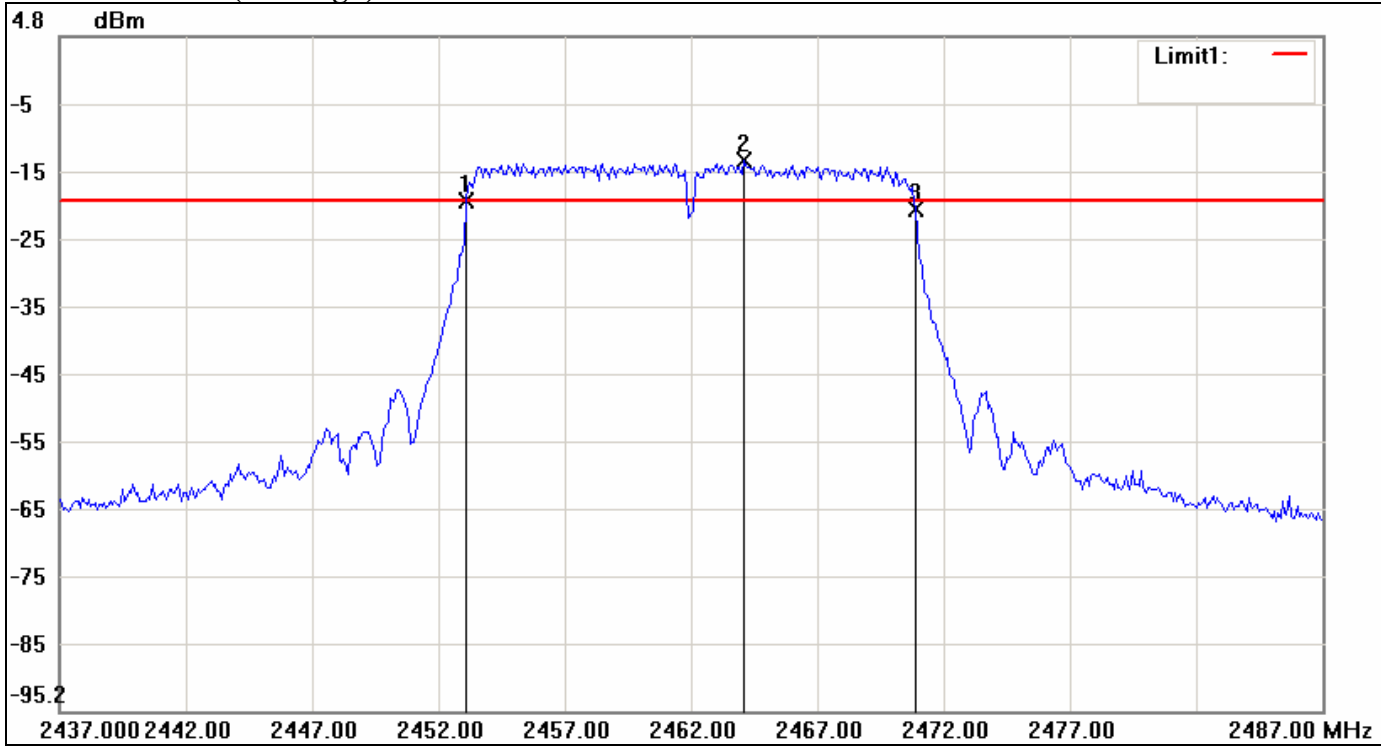

No.	Frequency(MHz)	Level(dBm)	Limit(dBm)	Margin(dBm)
1	2453.0833	-19.68	-19.59	-0.09
2	2464.0833	-13.59	-19.59	6.00
3	2470.9167	-20.82	-19.59	-1.23

No.		Δ Frequency(MHz)	Δ Level(dB)
1	mk3-mk1	17.8334	-1.14



IEEE 802.11n HT 20 MHz mode / Chain 1

6dB Bandwidth (CH Low)

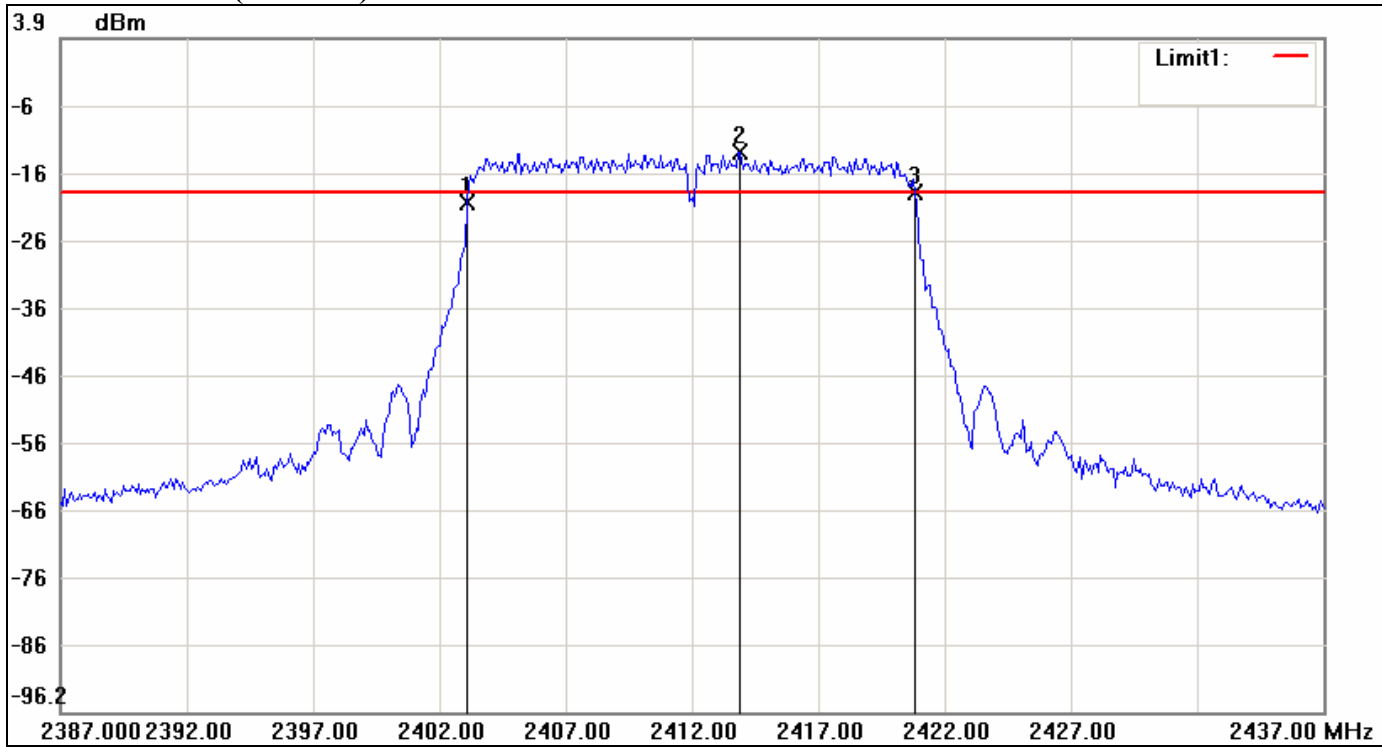

No.	Frequency(MHz)	Level(dBm)	Limit(dBm)	Margin(dBm)
1	2403.0833	-20.61	-19.00	-1.61
2	2413.9167	-13.00	-19.00	6.00
3	2420.8333	-19.06	-19.00	-0.06

No.		Δ Frequency(MHz)	Δ Level(dB)
1	mk3-mk1	17.75	1.55



6dB Bandwidth (CH Mid)

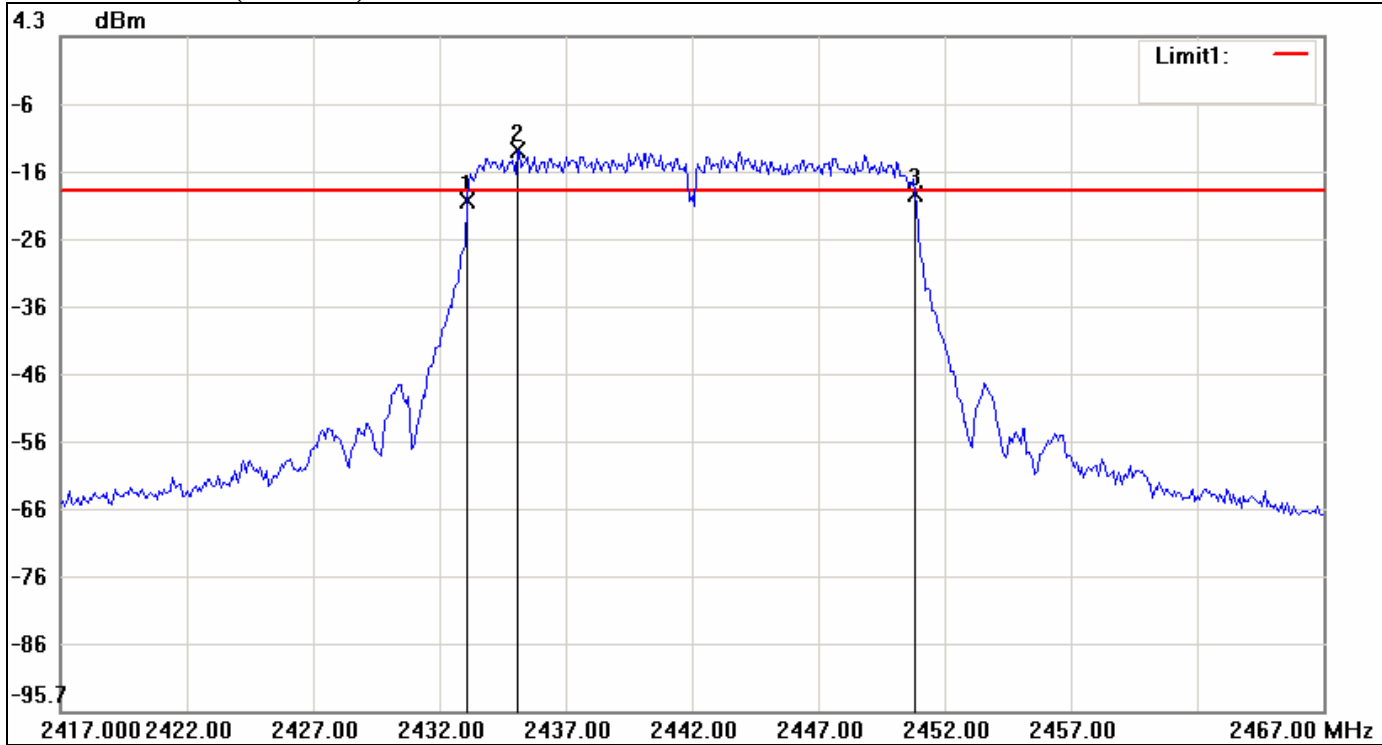

No.	Frequency(MHz)	Level(dBm)	Limit(dBm)	Margin(dBm)
1	2433.0833	-20.09	-18.50	-1.59
2	2435.0833	-12.50	-18.50	6.00
3	2450.8333	-18.95	-18.50	-0.45

No.		Δ Frequency(MHz)	Δ Level(dB)
1	mk3-mk1	17.75	1.14



6dB Bandwidth (CH High)

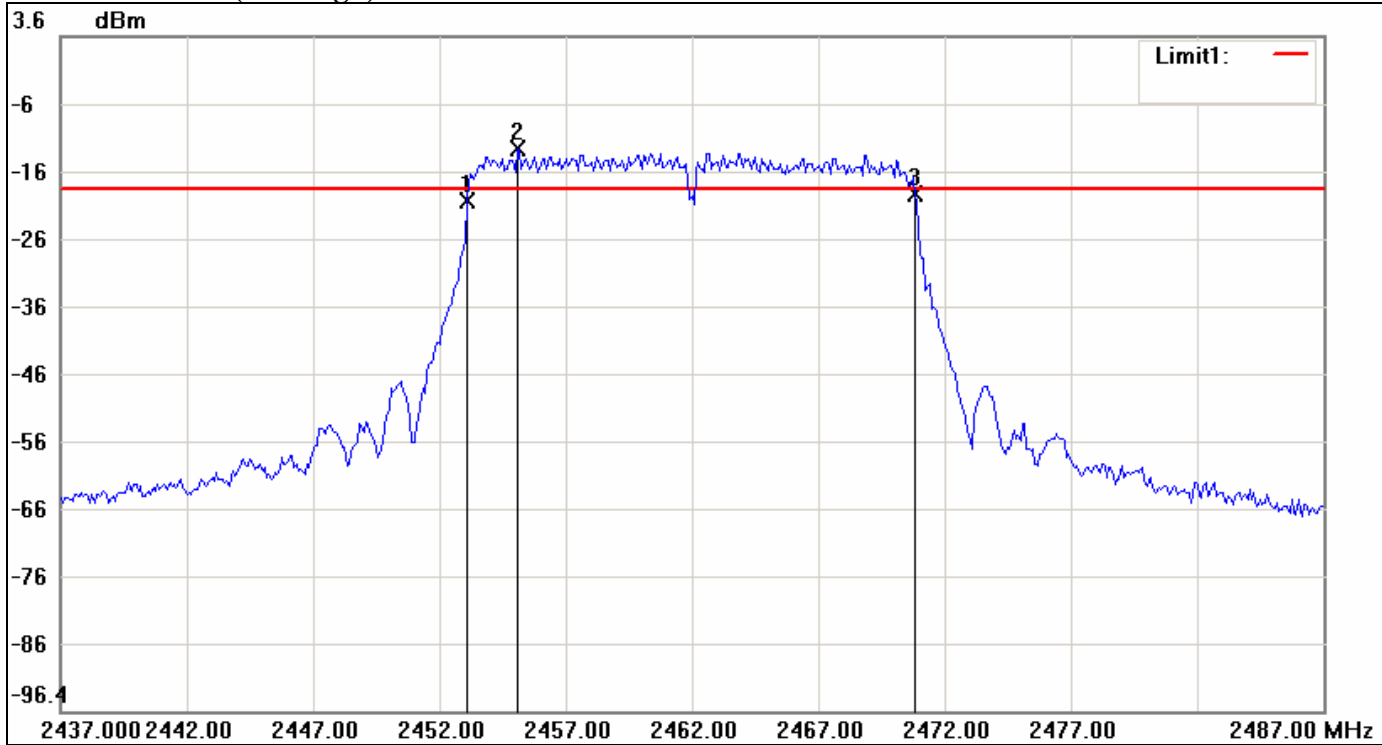

No.	Frequency(MHz)	Level(dBm)	Limit(dBm)	Margin(dBm)
1	2453.0833	-20.86	-19.04	-1.82
2	2455.0833	-13.04	-19.04	6.00
3	2470.8333	-19.70	-19.04	-0.66

No.		Δ Frequency(MHz)	Δ Level(dB)
1	mk3-mk1	17.75	1.16



IEEE 802.11n HT 20 MHz mode / Chain 2

6dB Bandwidth (CH Low)

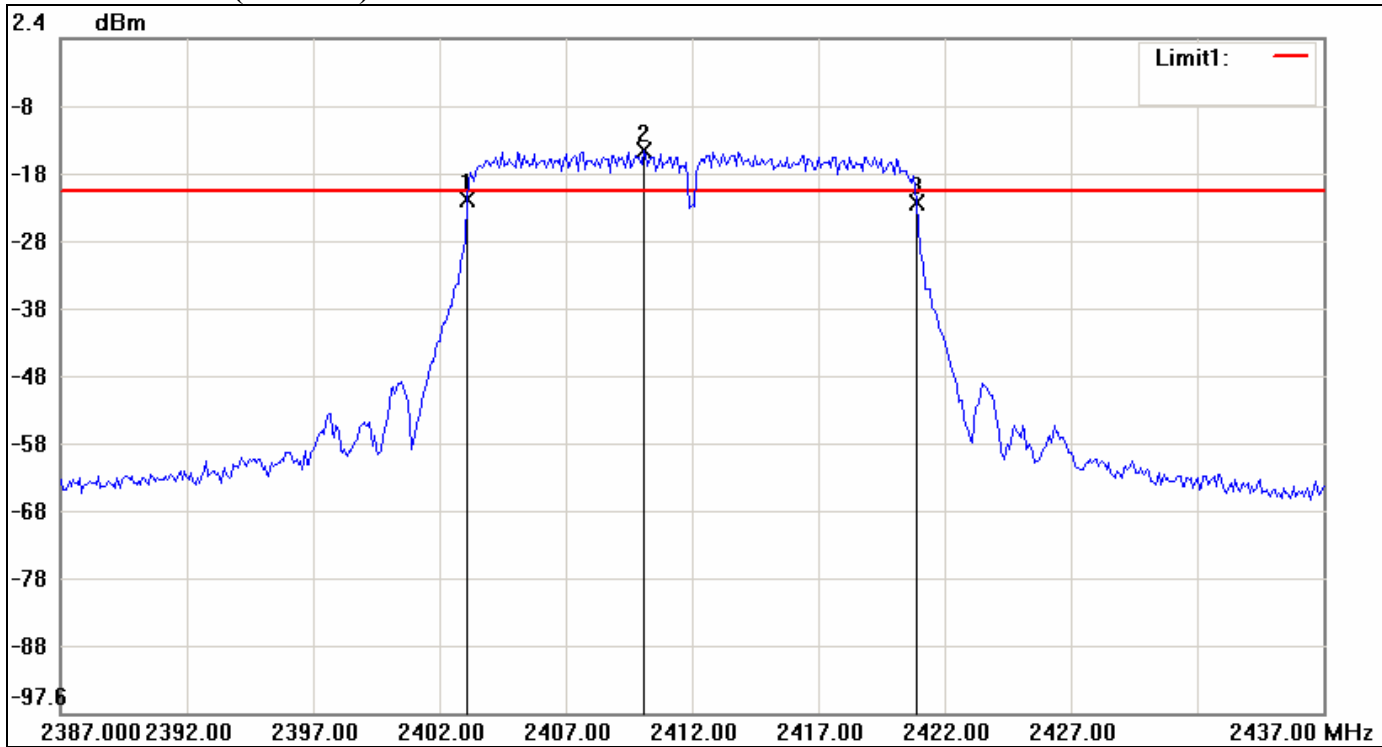

No.	Frequency(MHz)	Level(dBm)	Limit(dBm)	Margin(dBm)
1	2403.0833	-21.61	-20.16	-1.45
2	2410.833	-14.16	-20.16	6.00
3	2420.9167	-21.99	-20.16	-1.83

No.		Δ Frequency(MHz)	Δ Level(dB)
1	mk3-mk1	17.8334	-0.38



6dB Bandwidth (CH Mid)

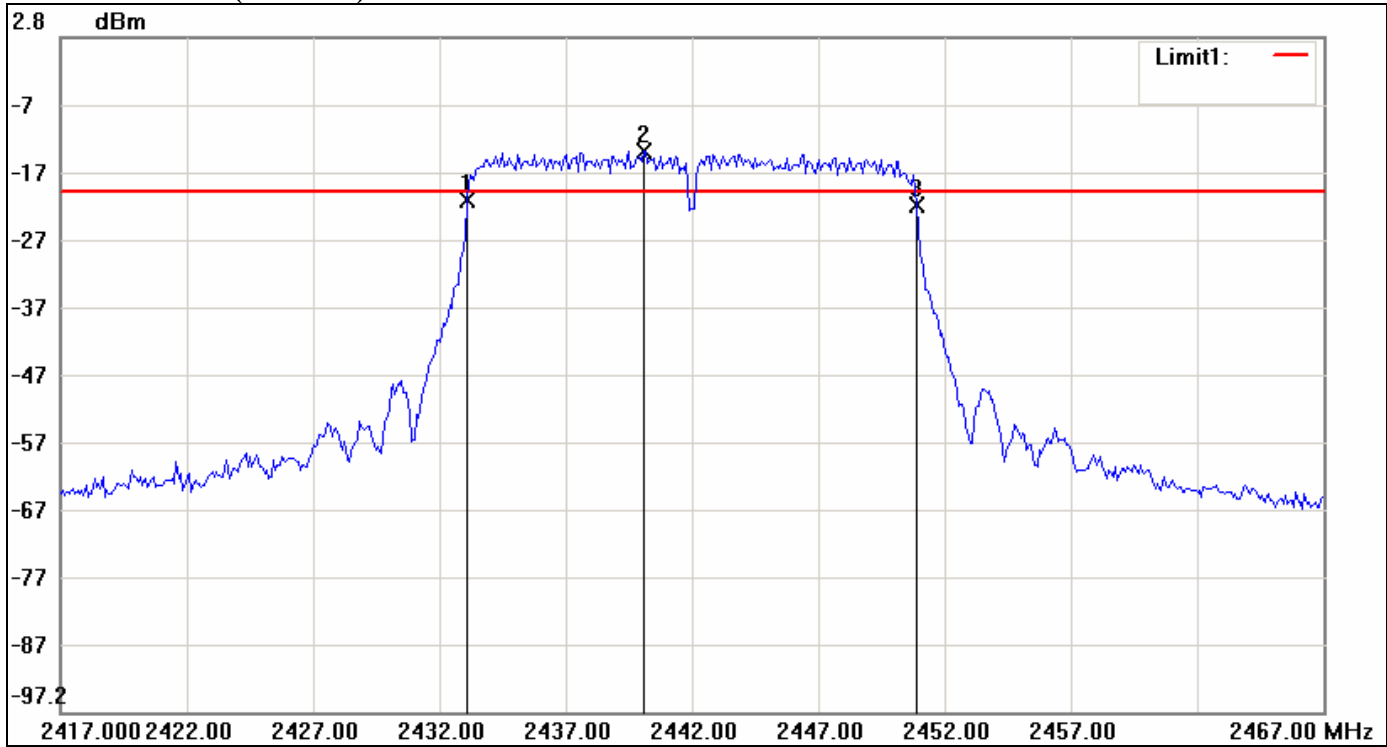

No.	Frequency(MHz)	Level(dBm)	Limit(dBm)	Margin(dBm)
1	2433.0833	-21.41	-20.03	-1.38
2	2440.0833	-14.03	-20.03	6.00
3	2450.9167	-22.18	-20.03	-2.15

No.		Δ Frequency(MHz)	Δ Level(dB)
1	mk3-mk1	17.8334	-0.77



6dB Bandwidth (CH High)

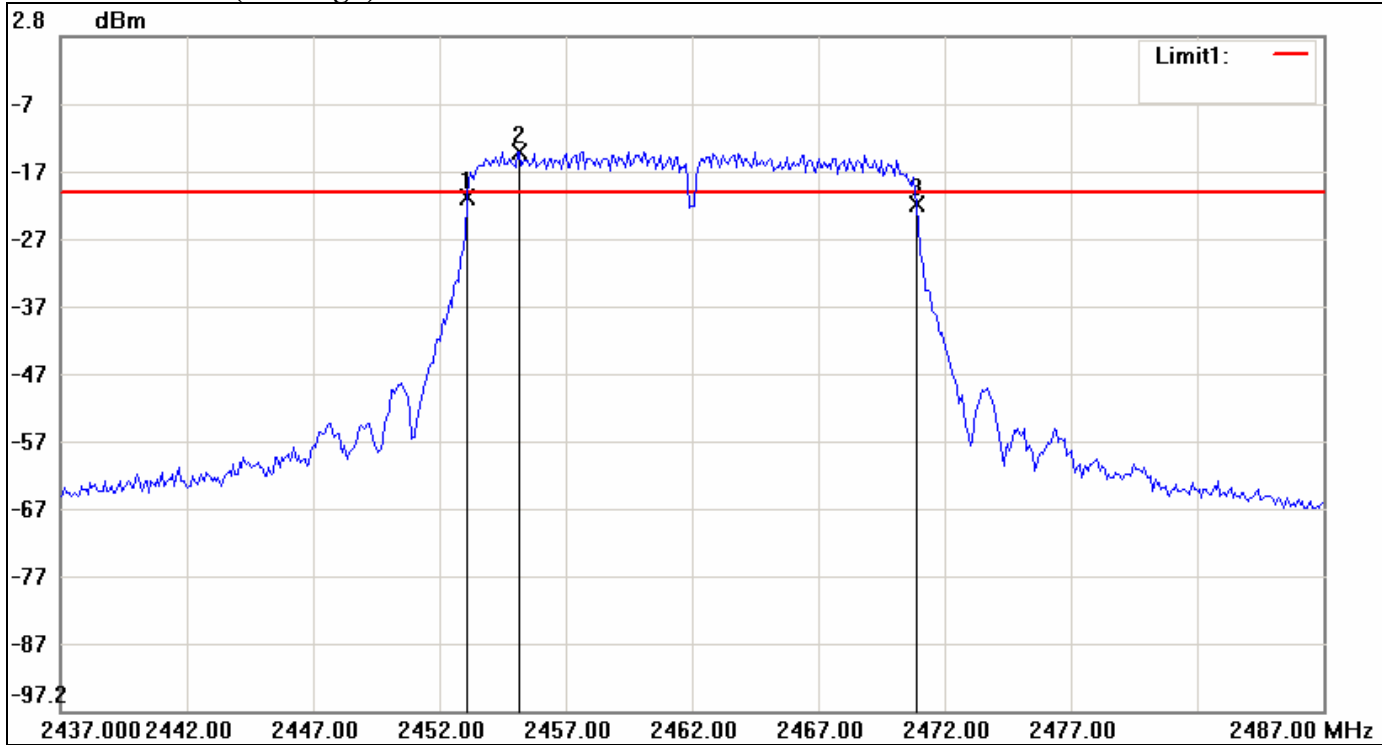

No.	Frequency(MHz)	Level(dBm)	Limit(dBm)	Margin(dBm)
1	2453.0833	-21.16	-20.21	-0.95
2	2455.1667	-14.21	-20.21	6.00
3	2470.9167	-22.16	-20.21	-1.95

No.		Δ Frequency(MHz)	Δ Level(dB)
1	mk3-mk1	17.8334	-1



IEEE 802.11n HT 40 MHz mode / Chain 0

6dB Bandwidth (CH Low)

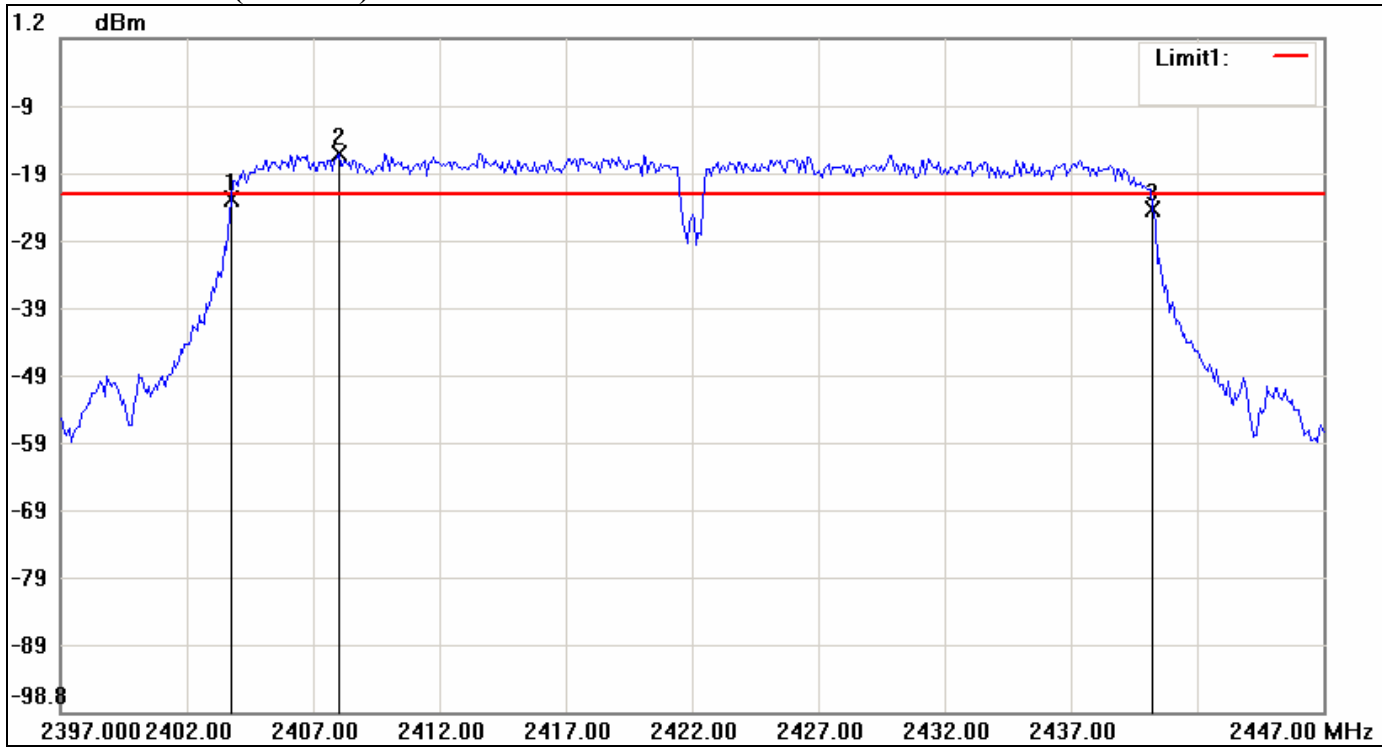

No.	Frequency(MHz)	Level(dBm)	Limit(dBm)	Margin(dBm)
1	2403.7500	-22.54	-21.88	-0.66
2	2408.0000	-15.88	-21.88	6.00
3	2440.2500	-24.01	-21.88	-2.13

No.		Δ Frequency(MHz)	Δ Level(dB)
1	mk3-mk1	36.5	-1.47



6dB Bandwidth (CH Mid)

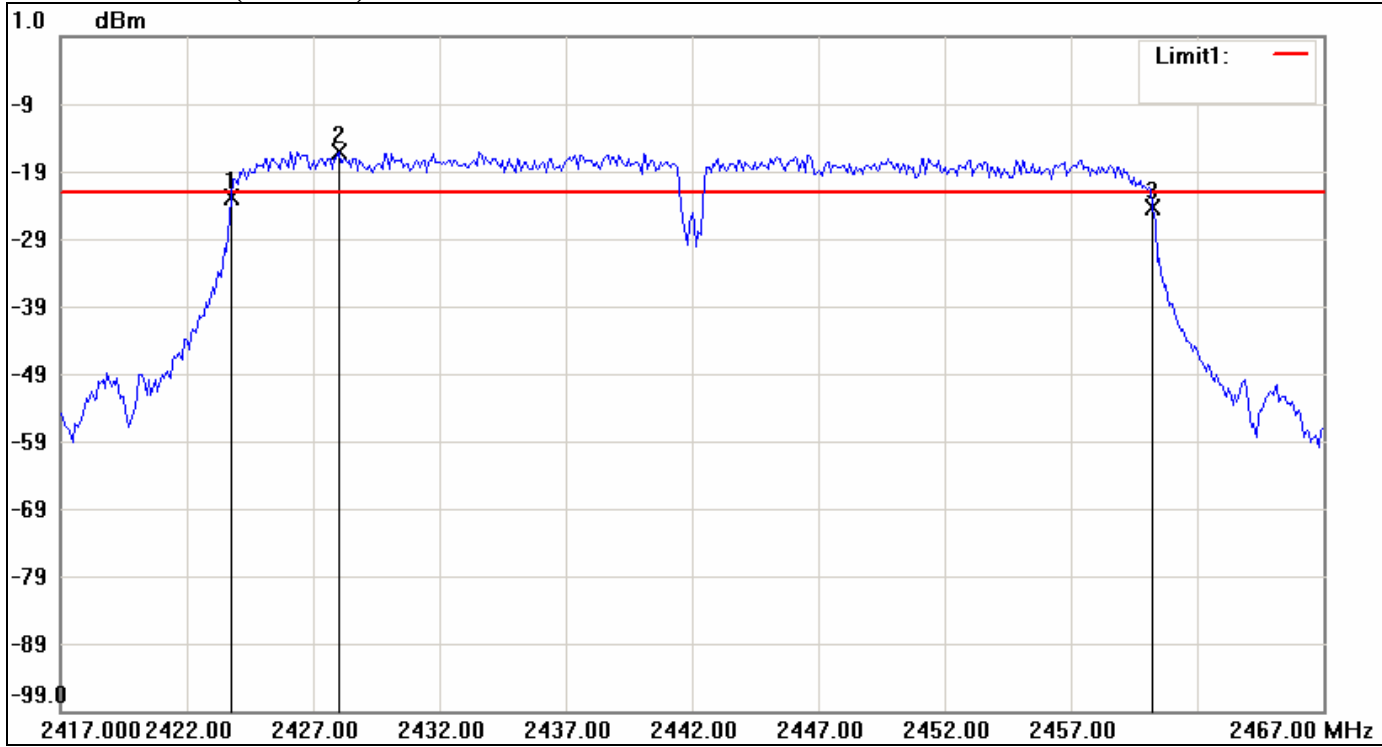

No.	Frequency(MHz)	Level(dBm)	Limit(dBm)	Margin(dBm)
1	2423.7500	-22.75	-22.05	-0.70
2	2428.0000	-16.05	-22.05	6.00
3	2460.2500	-24.32	-22.05	-2.27

No.		Δ Frequency(MHz)	Δ Level(dB)
1	mk3-mk1	36.5	-1.57



6dB Bandwidth (CH High)

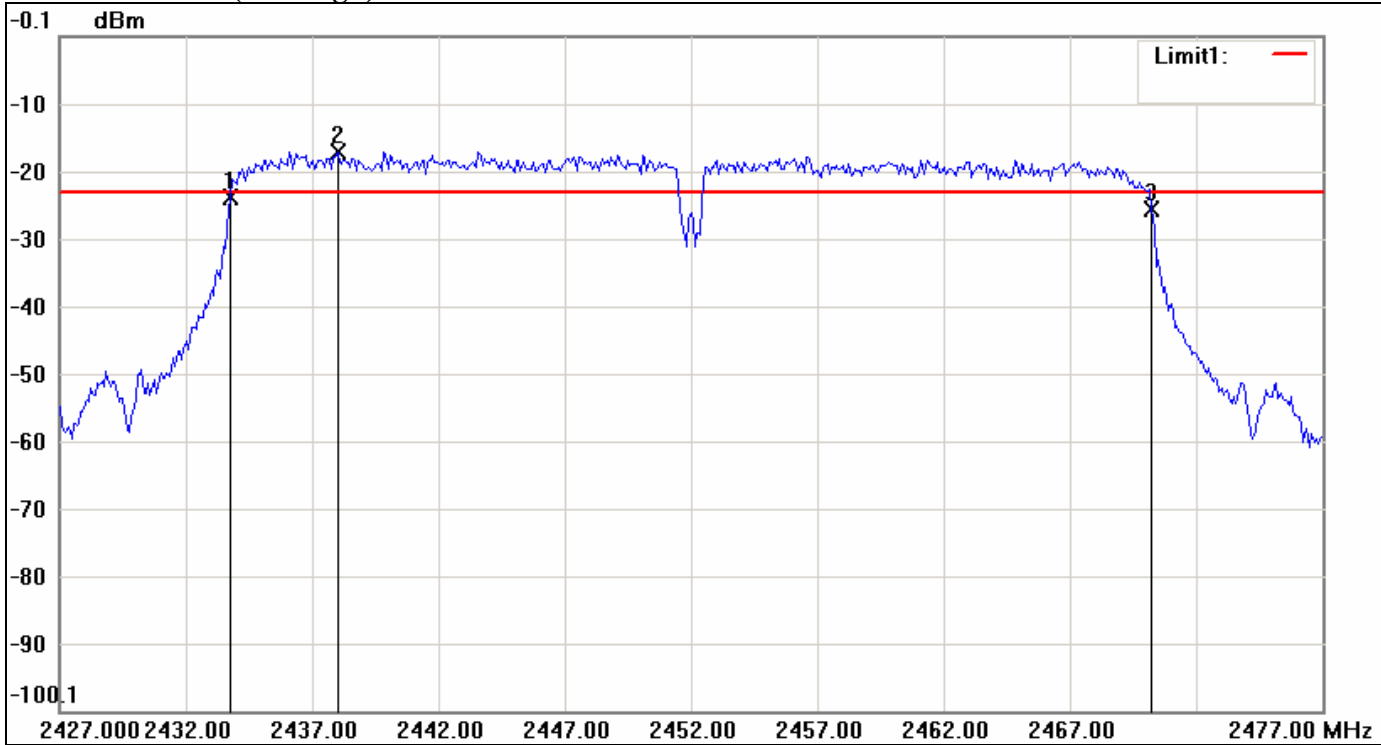

No.	Frequency(MHz)	Level(dBm)	Limit(dBm)	Margin(dBm)
1	2433.7500	-23.91	-23.30	-0.61
2	2438.0000	-17.30	-23.30	6.00
3	2470.2500	-25.76	-23.30	-2.46

No.		Δ Frequency(MHz)	Δ Level(dB)
1	mk3-mk1	36.5	-1.85



IEEE 802.11n HT 40 MHz mode / Chain 1

6dB Bandwidth (CH Low)

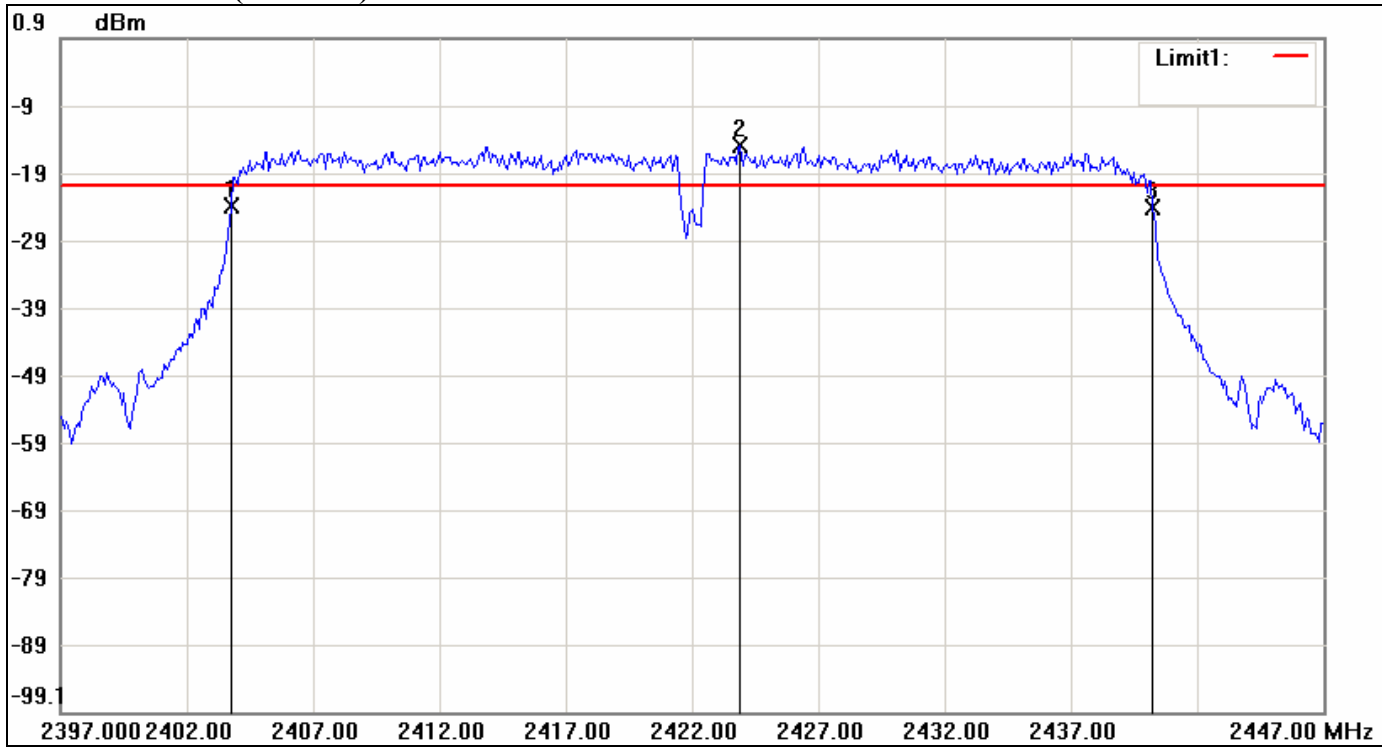

No.	Frequency(MHz)	Level(dBm)	Limit(dBm)	Margin(dBm)
1	2403.7500	-23.94	-21.03	-2.91
2	2423.9167	-15.03	-21.03	6.00
3	2440.2500	-24.14	-21.03	-3.11

No.		Δ Frequency(MHz)	Δ Level(dB)
1	mk3-mk1	36.5	-0.2



6dB Bandwidth (CH Mid)

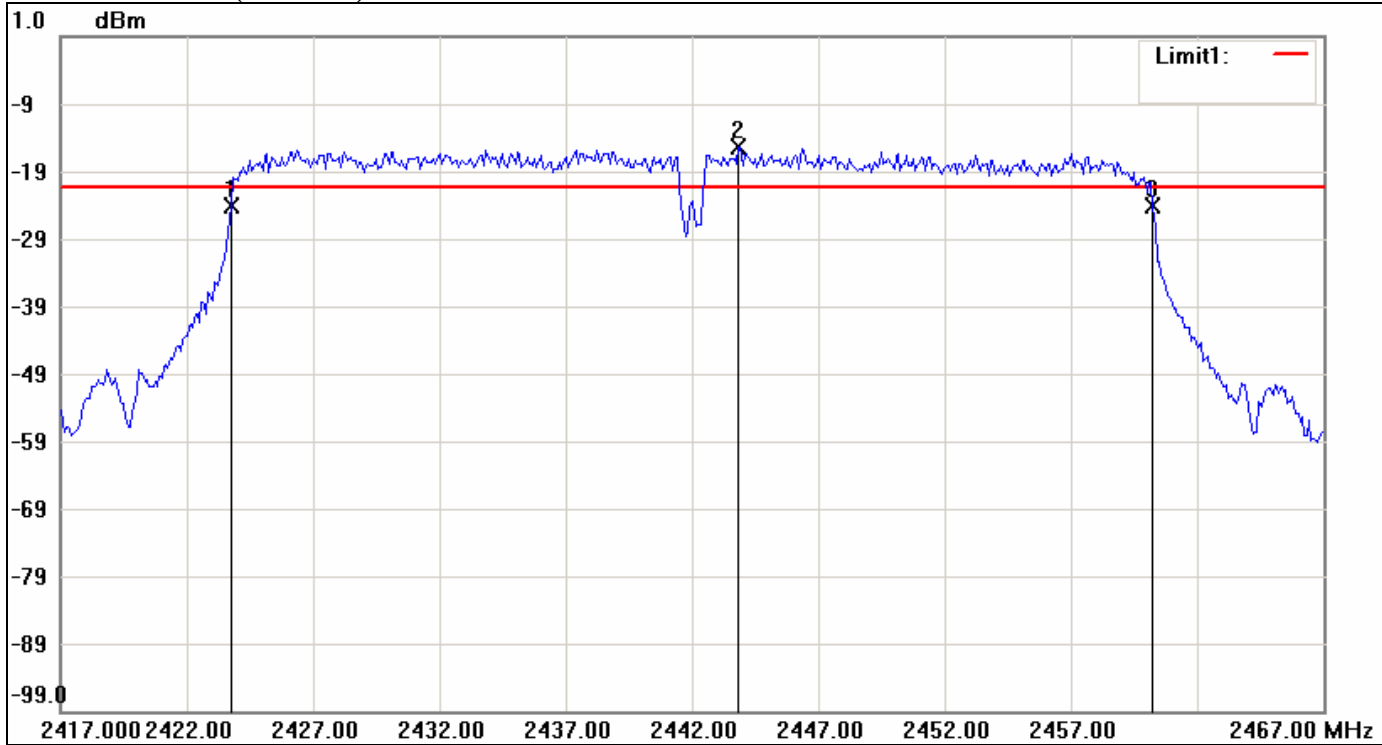

No.	Frequency(MHz)	Level(dBm)	Limit(dBm)	Margin(dBm)
1	2423.7500	-24.03	-21.25	-2.78
2	2443.8333	-15.25	-21.25	6.00
3	2460.2500	-24.16	-21.25	-2.91

No.		Δ Frequency(MHz)	Δ Level(dB)
1	mk3-mk1	36.5	-0.13



6dB Bandwidth (CH High)

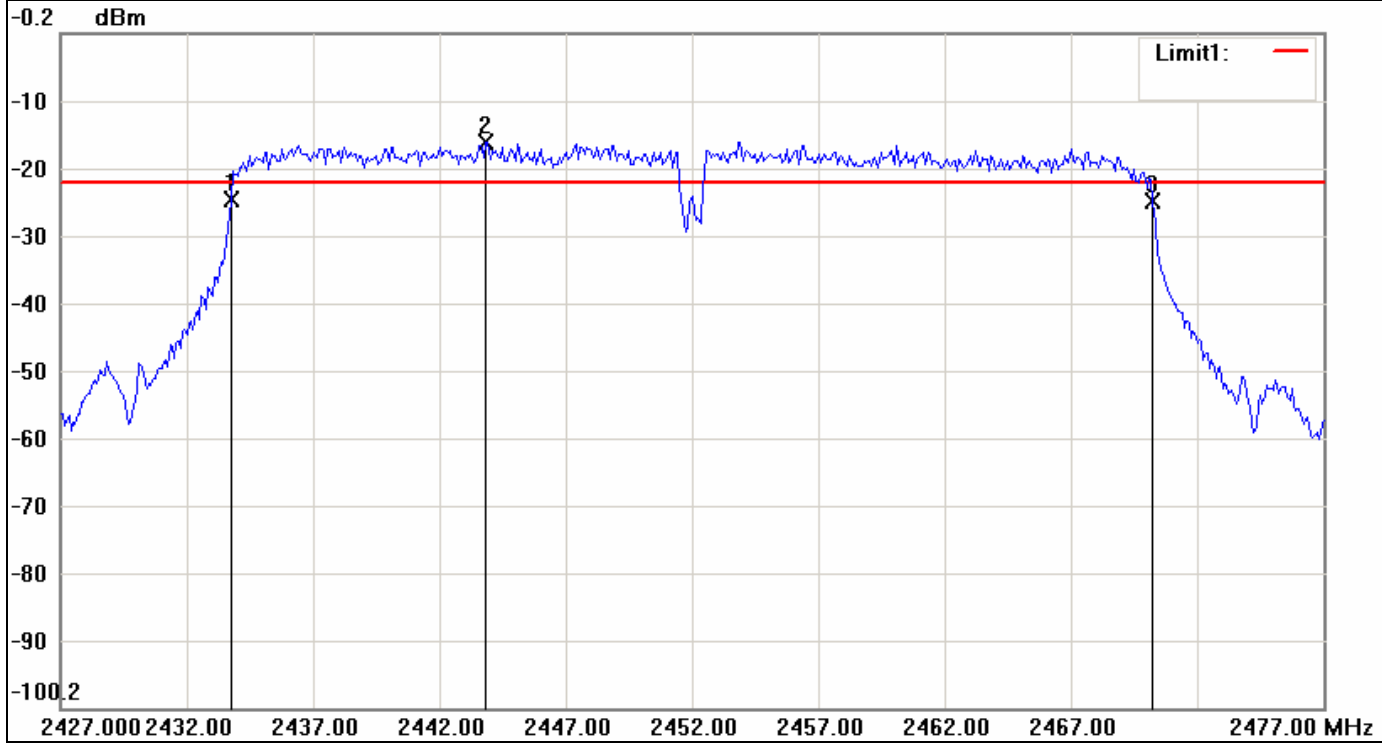

No.	Frequency(MHz)	Level(dBm)	Limit(dBm)	Margin(dBm)
1	2433.7500	-24.89	-22.19	-2.70
2	2443.8333	-16.19	-22.19	6.00
3	2470.2500	-25.10	-22.19	-2.91

No.		Δ Frequency(MHz)	Δ Level(dB)
1	mk3-mk1	36.5	-0.21



IEEE 802.11n HT 40 MHz mode / Chain 2

6dB Bandwidth (CH Low)

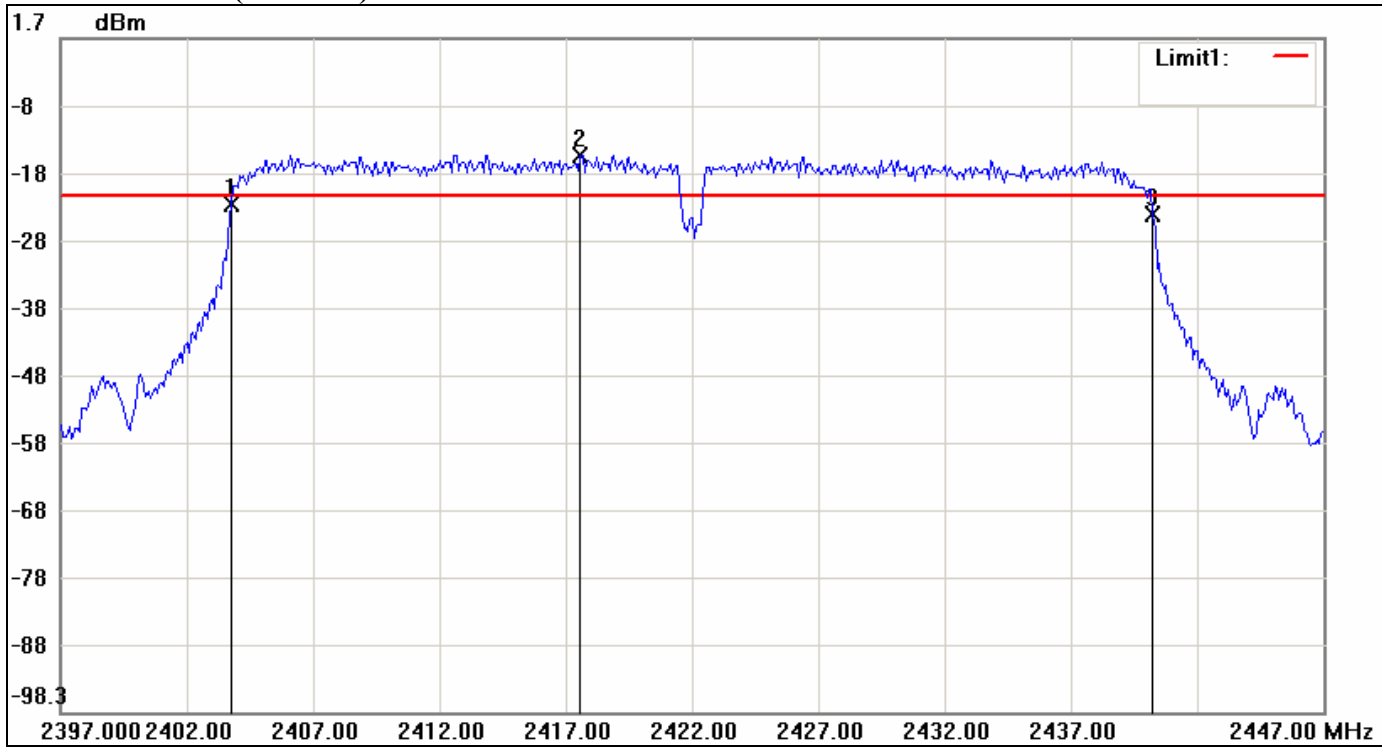

No.	Frequency(MHz)	Level(dBm)	Limit(dBm)	Margin(dBm)
1	2403.7500	-22.92	-21.55	-1.37
2	2417.5833	-15.55	-21.55	6.00
3	2440.2500	-24.31	-21.55	-2.76

No.		Δ Frequency(MHz)	Δ Level(dB)
1	mk3-mk1	36.5	-1.39



6dB Bandwidth (CH Mid)

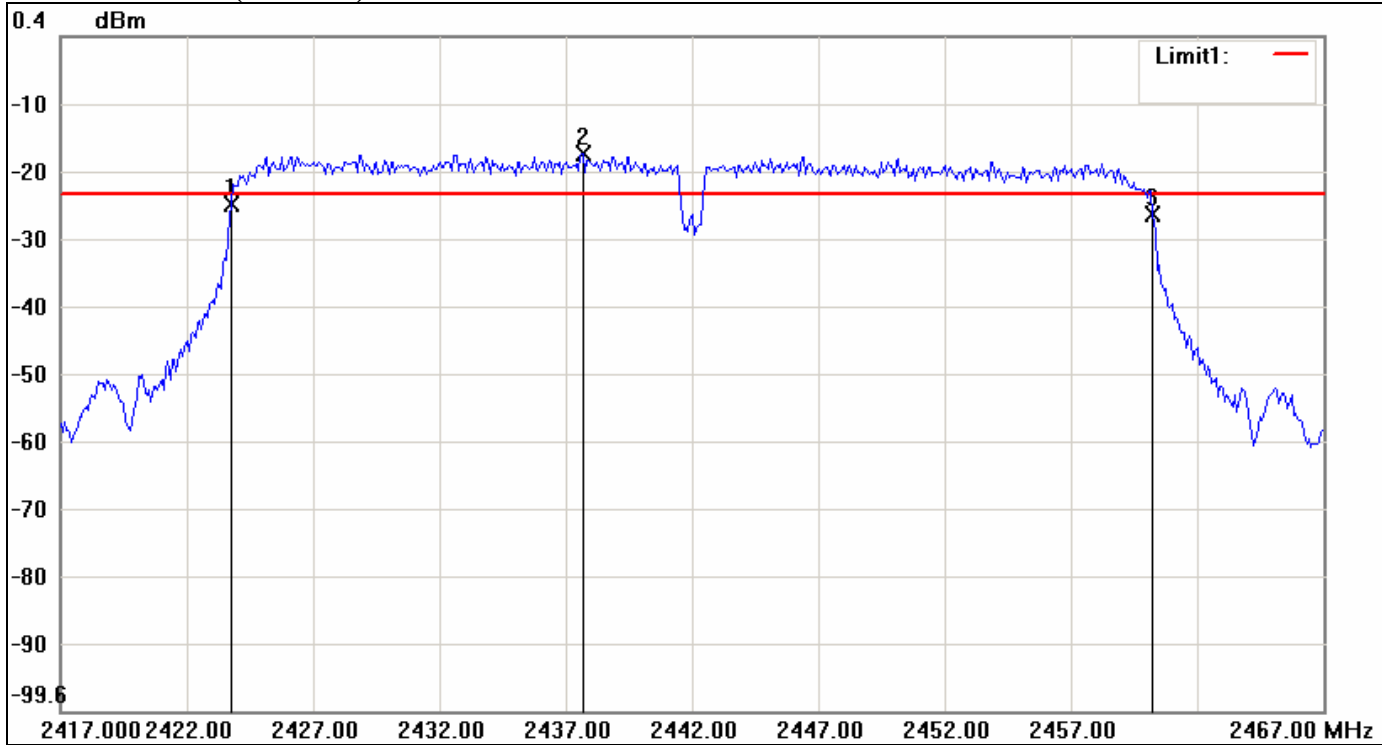

No.	Frequency(MHz)	Level(dBm)	Limit(dBm)	Margin(dBm)
1	2423.7500	-24.57	-22.93	-1.64
2	2442.6667	-16.93	-22.93	6.00
3	2460.2500	-26.05	-22.93	-3.12

No.		Δ Frequency(MHz)	Δ Level(dB)
1	mk3-mk1	36.5	-1.48



6dB Bandwidth (CH High)

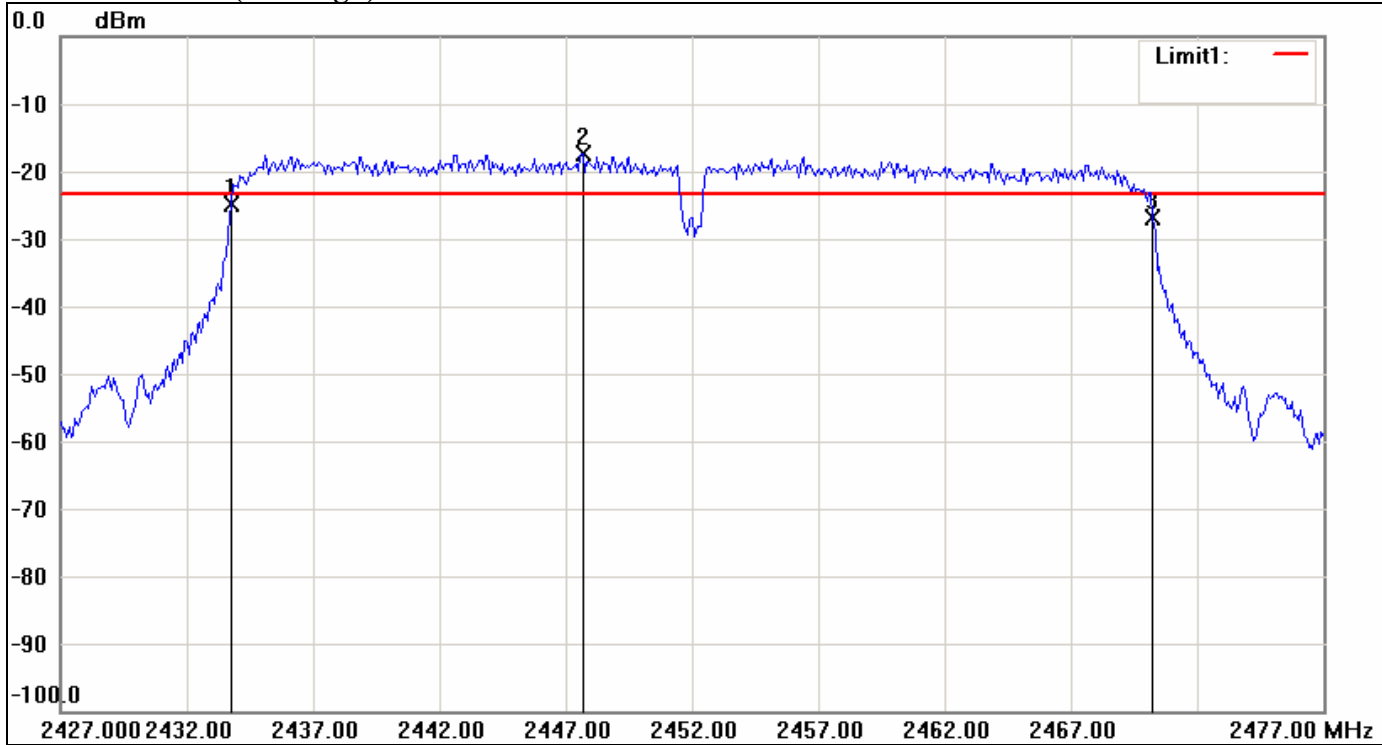

No.	Frequency(MHz)	Level(dBm)	Limit(dBm)	Margin(dBm)
1	2433.7500	-24.83	-23.53	-1.30
2	2447.6667	-17.53	-23.53	6.00
3	2470.2500	-26.84	-23.53	-3.31

No.		Δ Frequency(MHz)	Δ Level(dB)
1	mk3-mk1	36.5	-2.01



7.2 PEAK POWER

LIMIT

The maximum peak output power of the intentional radiator shall not exceed the following:

1. According to §15.247(b)(3), for systems using digital modulation in the bands of 902-928 MHz, 2400-2483.5 MHz, and 5725-5850 MHz: 1 Watt.
2. According to §15.247(b)(4), the conducted output power limit specified in paragraph (b) of this section is based on the use of antennas with directional gains that do not exceed 6 dBi. Except as shown in paragraph (c) of this section, if transmitting antennas of directional gain greater than 6 dBi are used, the conducted output power from the intentional radiator shall be reduced below the stated values in paragraphs (b)(1), (b)(2), and (b)(3) of this section, as appropriate, by the amount in dB that the directional gain of the antenna exceeds 6 dBi.

Test Configuration

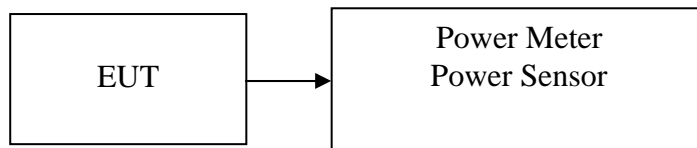

TEST PROCEDURE

The transmitter output is connected to the Power Meter. The Power Meter is set to the peak power detection.

TEST RESULTS

No non-compliance noted

**Test Data****Test mode: IEEE 802.11b mode**

Channel	Frequency (MHz)	Output Power (dBm)	Output Power (W)	Limit (W)	Test Result
Low	2412	18.03	0.0635	1	PASS
Mid	2442	17.98	0.0628		PASS
High	2462	17.91	0.0618		PASS

Test mode: IEEE 802.11g mode

Channel	Frequency (MHz)	Output Power (dBm)	Output Power (W)	Limit (W)	Test Result
Low	2412	14.81	0.0303	1	PASS
Mid	2442	15.09	0.0323		PASS
High	2462	14.69	0.0294		PASS

Test mode: IEEE 802.11n HT 20 MHz mode

Channel	Frequency (MHz)	Chain 0 Output Power (dBm)	Chain 1 Output Power (dBm)	Chain 2 Output Power (dBm)	Total Output Power (dBm)	Output Power (W)	Limit (W)	Result
Low	2412	10.16	10.06	10.14	14.89	0.0308	1	PASS
Mid	2442	9.92	10.24	10.08	14.85	0.0305		PASS
High	2462	9.98	9.76	10.12	14.73	0.0297		PASS

Test mode: IEEE 802.11n HT 40 MHz mode

Channel	Frequency (MHz)	Chain 0 Output Power (dBm)	Chain 1 Output Power (dBm)	Chain 2 Output Power (dBm)	Total Output Power (dBm)	Output Power (W)	Limit (W)	Result
Low	2422	10.14	9.87	9.87	14.73	0.0297	1	PASS
Mid	2442	10.28	9.88	9.59	14.70	0.0295		PASS
High	2452	10.16	9.94	9.86	14.76	0.0299		PASS

Remark: Total Output Power (w) = Chain 0 ($10^{(Output Power / 10) / 1000}$) + Chain 1 ($10^{(Output Power / 10) / 1000}$) + Chain 2 ($10^{(Output Power / 10) / 1000}$)



7.3 AVERAGE POWER

LIMIT

None; for reporting purposes only.

Test Configuration

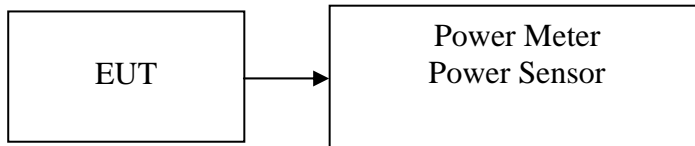

TEST PROCEDURE

The transmitter output is connected to the Power Meter. The Power Meter is set to the peak power detection.

TEST RESULTS

No non-compliance noted

**Test Data****Test mode: IEEE 802.11b mode**

Channel	Frequency (MHz)	Output Power (dBm)	Output Power (W)
Low	2412	16.11	0.0408
Mid	2442	16.05	0.0403
High	2462	15.98	0.0396

Test mode: IEEE 802.11g mode

Channel	Frequency (MHz)	Output Power (dBm)	Output Power (W)
Low	2412	4.73	0.0030
Mid	2442	5.71	0.0037
High	2462	4.66	0.0029

Test mode: IEEE 802.11n HT 20 MHz mode

Channel	Frequency (MHz)	Chain 0 Output Power (dBm)	Chain 1 Output Power (dBm)	Chain 2 Output Power (dBm)	Total Output Power (dBm)	Output Power (W)
Low	2412	0.74	0.47	0.01	5.19	0.0033
Mid	2442	0.54	0.72	-0.09	5.17	0.0033
High	2462	0.49	0.13	-0.03	4.97	0.0031

Test mode: IEEE 802.11n HT 40 MHz mode

Channel	Frequency (MHz)	Chain 0 Output Power (dBm)	Chain 1 Output Power (dBm)	Chain 2 Output Power (dBm)	Total Output Power (dBm)	Output Power (W)
Low	2422	0.12	0.21	0.03	4.89	0.0031
Mid	2442	0.71	0.81	-0.47	5.16	0.0033
High	2452	0.22	0.87	0.01	5.15	0.0033

Remark: Total Output Power (w) = Chain 0 ($10^{(Output Power / 10) / 1000}$) + Chain 1 ($10^{(Output Power / 10) / 1000}$) + Chain 2 ($10^{(Output Power / 10) / 1000}$)



7.4 BAND EDGES MEASUREMENT

LIMIT

According to §15.247(d), in any 100 kHz bandwidth outside the frequency bands in which the spread spectrum intentional radiator is operating, the radio frequency power that is produced by the intentional radiator shall be at least 20 dB below that in the 100 kHz bandwidth within the band that contains the highest level of the desired power, based on either an RF conducted or a radiated measurement, provided the transmitter demonstrates compliance with the peak conducted power limits. In addition, radiated emissions which fall in the restricted bands, as defined in §15.205(a), must also comply with the radiated emission limits specified in 15.209(a) (see Section 15.205(c)).

Test Configuration

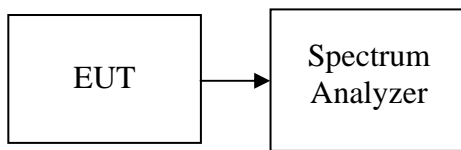

TEST PROCEDURE

Conducted RF measurements of the transmitter output were made to confirm that the EUT antenna port conducted emissions meet the specified limit and to identify any spurious signals that require further investigation or measurements on the radiated emissions site.

The transmitter output is connected to the spectrum analyzer. The resolution bandwidth is set to 100 kHz. The video bandwidth is set to 300 kHz.

TEST RESULTS

No non-compliance noted.



Band Edges (IEEE 802.11b mode / CH Low)

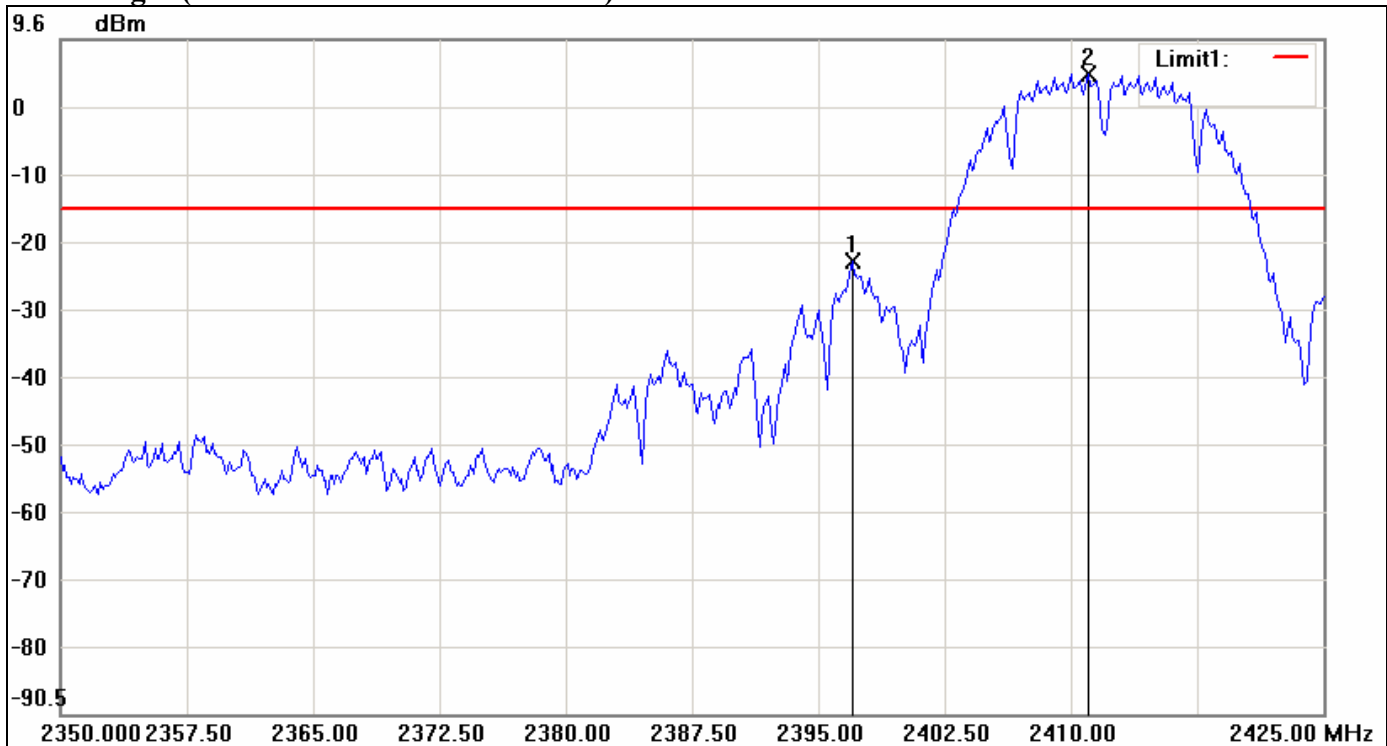

No.	Frequency(MHz)	Level(dBm)	Limit(dBm)	Margin(dBm)
1	2397.0000	-23.38	-15.66	-7.72
2	2411.0000	4.34	-15.66	20.00



Band Edges (IEEE 802.11b mode / CH High)



No.	Frequency(MHz)	Level(dBm)	Limit(dBm)	Margin(dBm)
1	2459.9900	4.21	-15.79	20.00
2	2487.9867	-37.58	-15.79	-21.79



Band Edges (IEEE 802.11g mode / CH Low)

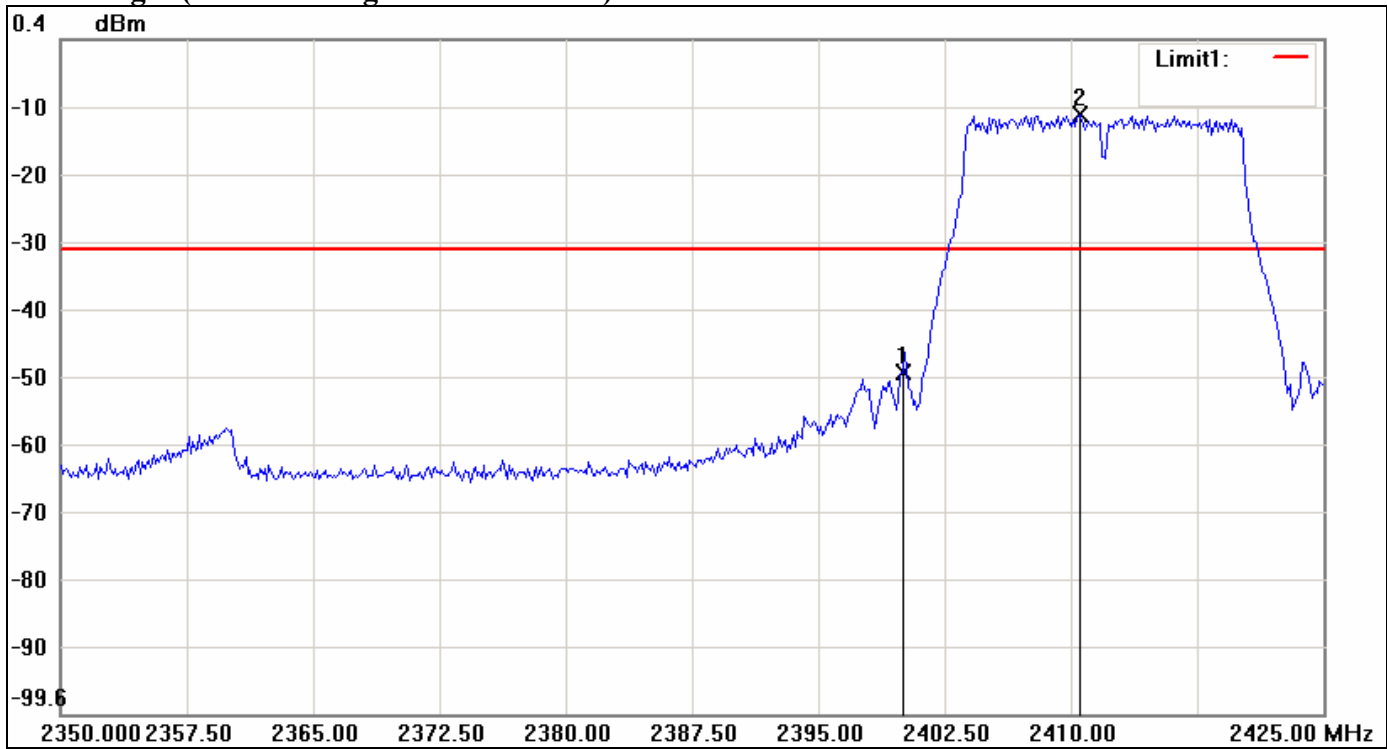

No.	Frequency(MHz)	Level(dBm)	Limit(dBm)	Margin(dBm)
1	2400.0000	-48.87	-30.84	-18.03
2	2410.5000	-10.84	-30.84	20.00



Band Edges (IEEE 802.11g mode / CH High)

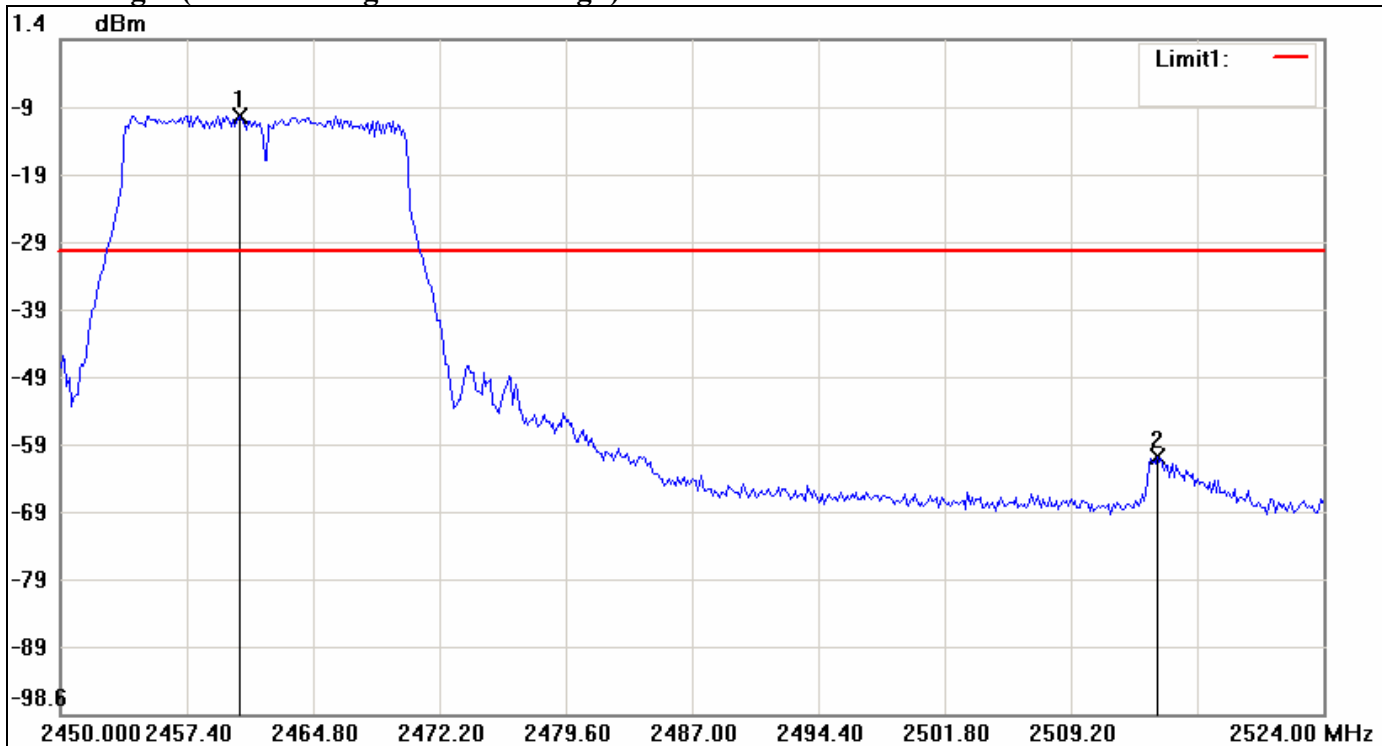

No.	Frequency(MHz)	Level(dBm)	Limit(dBm)	Margin(dBm)
1	2460.4833	-9.88	-29.88	20.00
2	2514.2567	-60.38	-29.88	-30.50



Band Edges (IEEE 802.11n HT 20 MHz mode / CH Low)

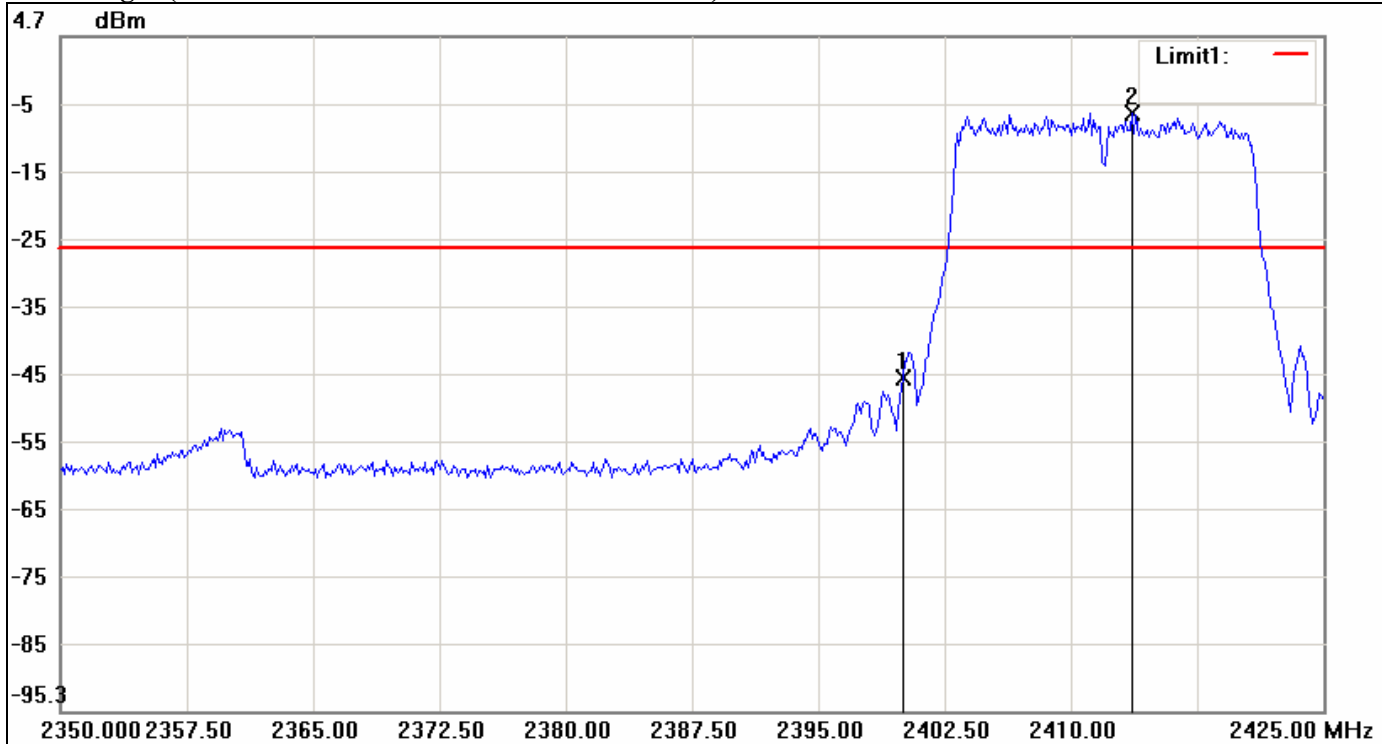

No.	Frequency(MHz)	Level(dBm)	Limit(dBm)	Margin(dBm)
1	2400.0000	-45.80	-26.60	-19.20
2	2413.6250	-6.60	-26.60	20.00



Band Edges (IEEE 802.11n HT 20 MHz mode / CH High)

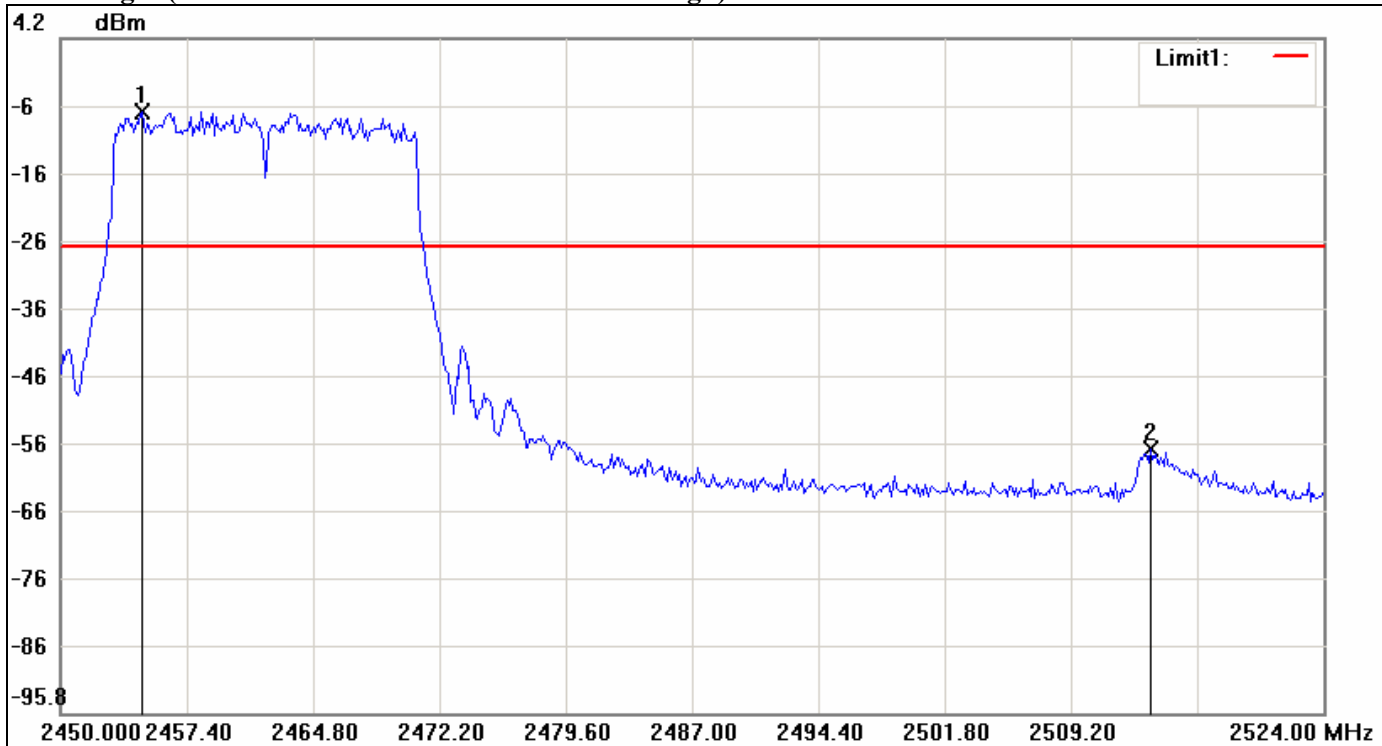

No.	Frequency(MHz)	Level(dBm)	Limit(dBm)	Margin(dBm)
1	2454.8100	-6.71	-26.71	20.00
2	2513.8867	-56.79	-26.71	-30.08



Band Edges (IEEE 802.11n HT 40 MHz mode / CH Low)

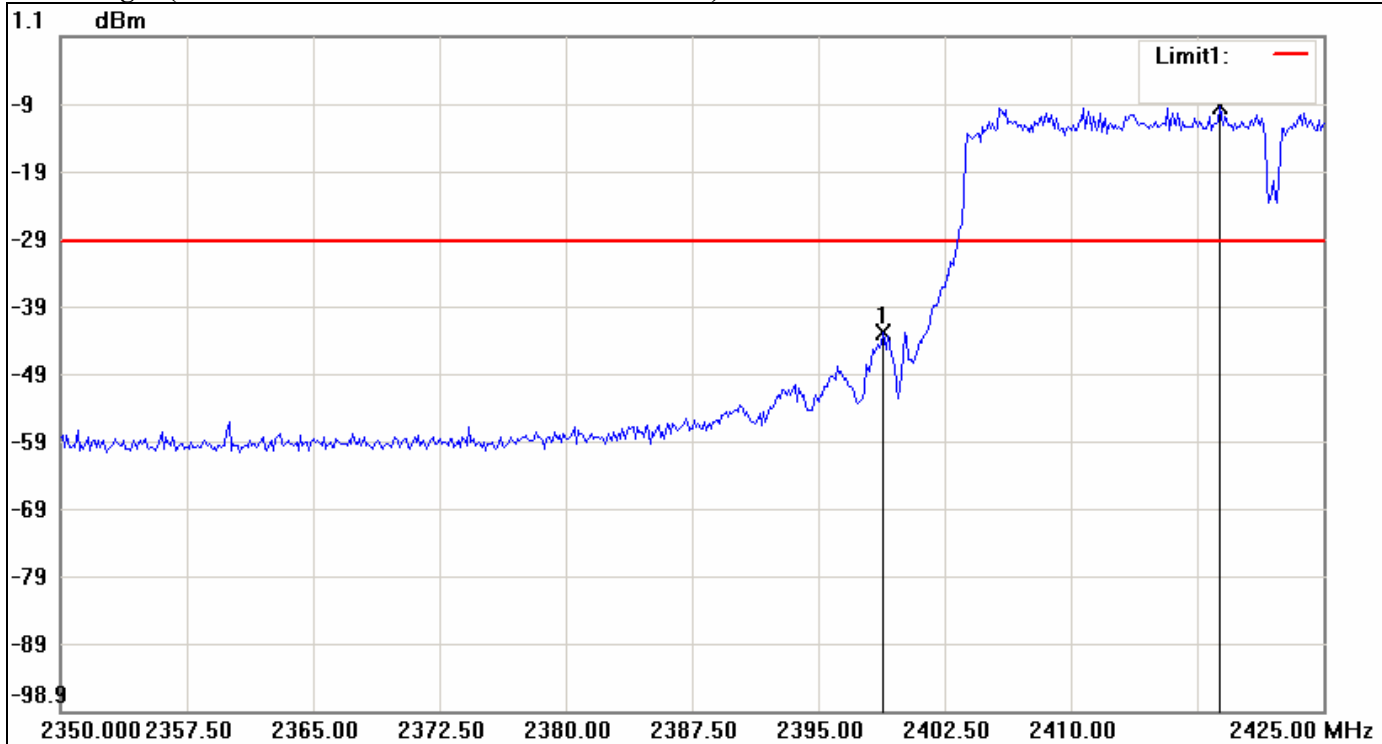

No.	Frequency(MHz)	Level(dBm)	Limit(dBm)	Margin(dBm)
1	2398.8750	-42.67	-29.20	-13.47
2	2418.8750	-9.20	-29.20	20.00



Band Edges (IEEE 802.11n HT 40 MHz mode / CH High)

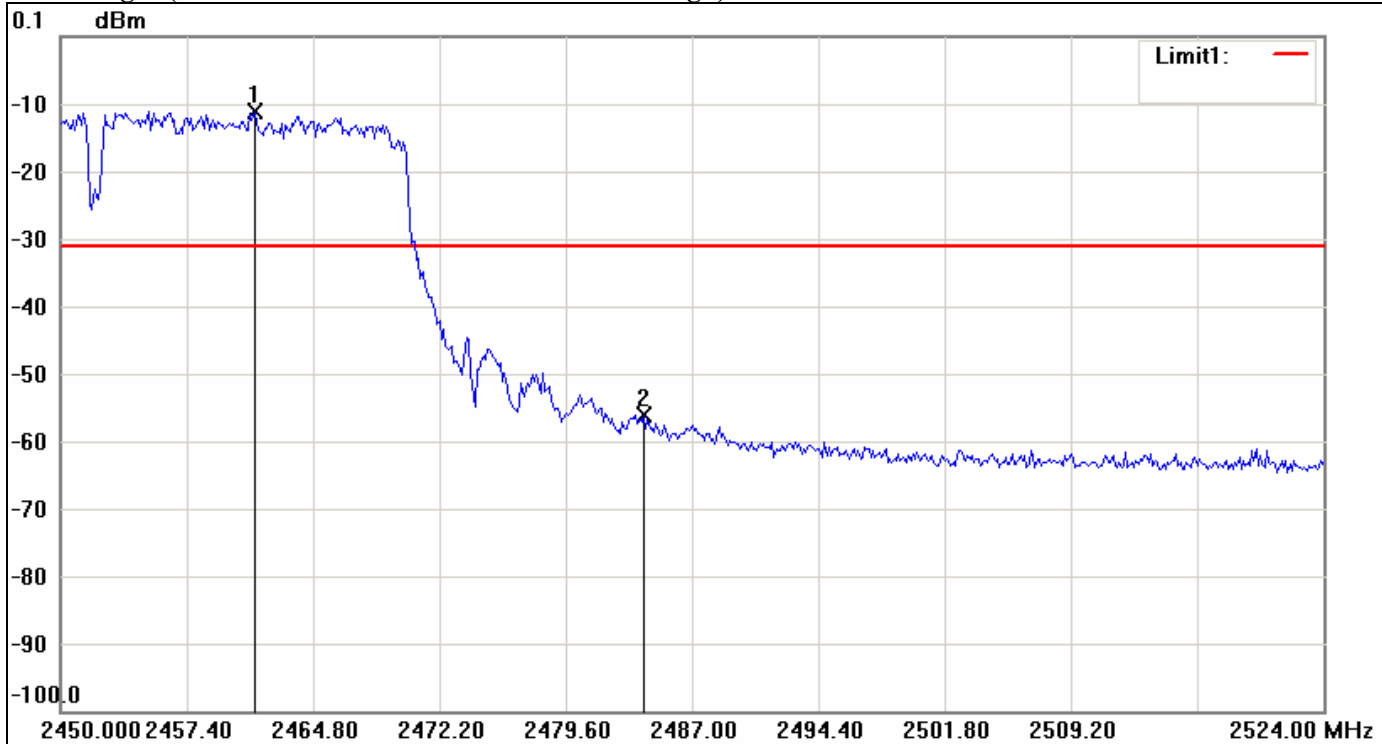

No.	Frequency(MHz)	Level(dBm)	Limit(dBm)	Margin(dBm)
1	2461.3467	-11.01	-31.01	20.00
2	2484.1633	-56.14	-31.01	-25.13



7.5 PEAK POWER SPECTRAL DENSITY

LIMIT

1. According to §15.247(e), for digitally modulated systems, the power spectral density conducted from the intentional radiator to the antenna shall not be greater than 8 dBm in any 3 kHz band during any time interval of continuous transmission.
2. According to §15.247(f), the digital modulation operation of the hybrid system, with the frequency hopping turned off, shall comply with the power density requirements of paragraph (d) of this section.

Test Configuration

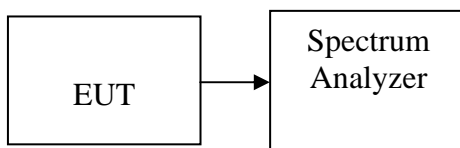

TEST PROCEDURE

1. Place the EUT on the table and set it in transmitting mode.
Remove the antenna from the EUT and then connect a low loss RF cable from the antenna port to the spectrum analyzer.
2. Set the spectrum analyzer as RBW = 3 kHz, VBW = 10 kHz, Sweep time = 100 s
3. Record the max reading.
4. Repeat the above procedure until the measurements for all frequencies are completed.

TEST RESULTS

No non-compliance noted

**Test Data****Test mode: IEEE 802.11b mode**

Channel	Frequency (MHz)	PPSD (dBm)	Limit (dBm)	Test Result
Low	2412	-13.83	8.00	PASS
Mid	2442	-13.87		PASS
High	2462	-13.95		PASS

Test mode: IEEE 802.11g mode

Channel	Frequency (MHz)	PPSD (dBm)	Limit (dBm)	Test Result
Low	2412	-25.99	8.00	PASS
Mid	2442	-23.87		PASS
High	2462	-24.93		PASS

Test mode: IEEE 802.11n HT 20 MHz mode

Channel	Frequency (MHz)	Chain 0 PPSD (dBm)	Chain 1 PPSD (dBm)	Chain 2 PPSD (dBm)	PPSD (dBm)	Limit (dBm)	Result
Low	2412	-28.60	-29.71	-29.47	-24.46	8.00	PASS
Mid	2442	-28.54	-29.58	-28.17	-23.95		PASS
High	2462	-28.63	-29.72	-28.05	-23.97		PASS

Test mode: IEEE 802.11n HT 40 MHz mode

Channel	Frequency (MHz)	Chain 0 PPSD (dBm)	Chain 1 PPSD (dBm)	Chain 2 PPSD (dBm)	PPSD (dBm)	Limit (dBm)	Result
Low	2422	-30.27	-29.66	-30.69	-25.41	8.00	PASS
Mid	2442	-30.43	-29.91	-31.73	-25.85		PASS
High	2452	-31.91	-31.57	-32.45	-27.19		PASS

Remark: Total PPSD (dBm) = $10 * \text{LOG}(10^{(\text{Chain 0 PPSD} / 10)} + 10^{(\text{Chain 1 PPSD} / 10)} + 10^{(\text{Chain 2 PPSD} / 10)})$



Test mode: IEEE 802.11n HT 20 MHz mode with combiner

Channel	Frequency (MHz)	PPSD (dBm)	Limit (dBm)	Result
Low	2412	-21.72	8.00	PASS
Mid	2442	-22.13		PASS
High	2462	-22.95		PASS

Test mode: IEEE 802.11n HT 40 MHz mode with combiner

Channel	Frequency (MHz)	PPSD (dBm)	Limit (dBm)	Result
Low	2422	-24.75	8.00	PASS
Mid	2442	-16.22		PASS
High	2452	-25.54		PASS



Test Plot

IEEE 802.11b mode

PPSD (CH Low)

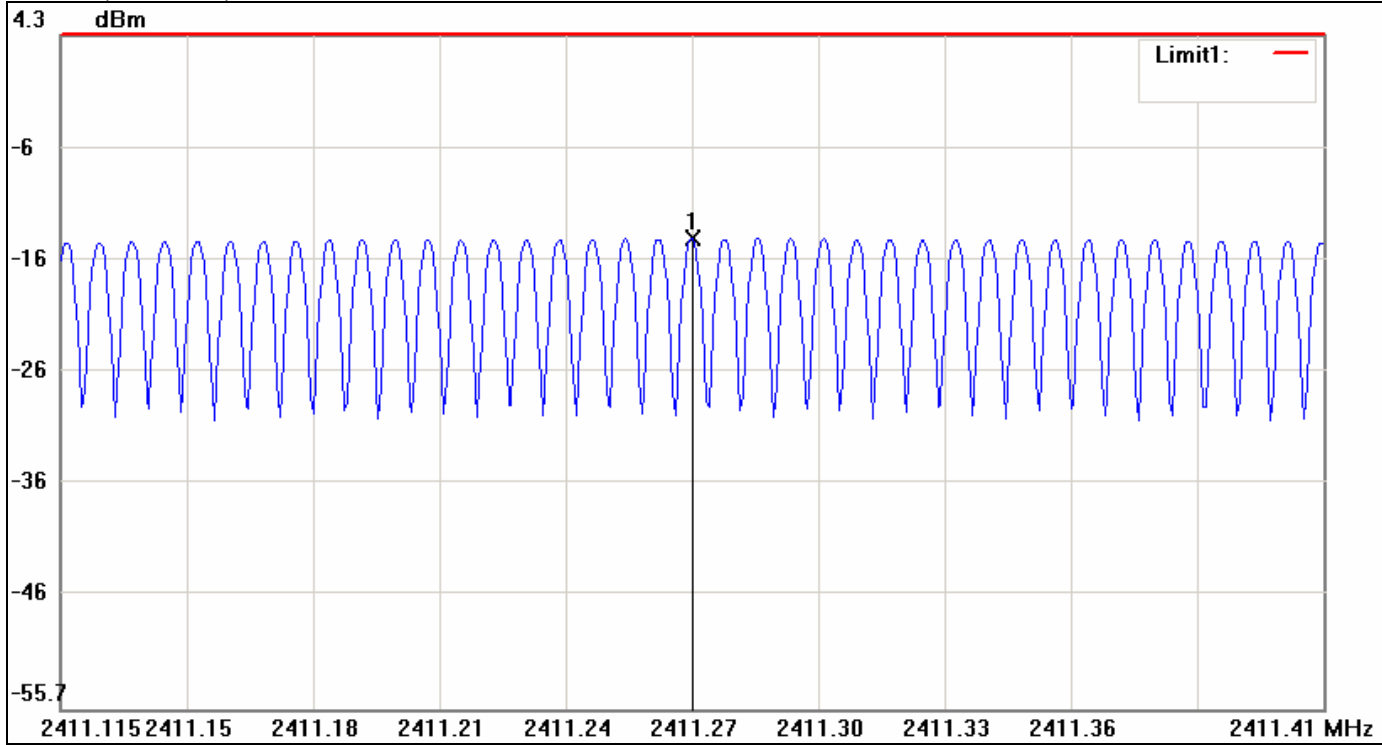

No.	Frequency(MHz)	Level(dBm)	Limit(dBm)	Margin(dBm)
1	2411.2654	-13.83	8.00	-21.83



PPSD (CH Mid)

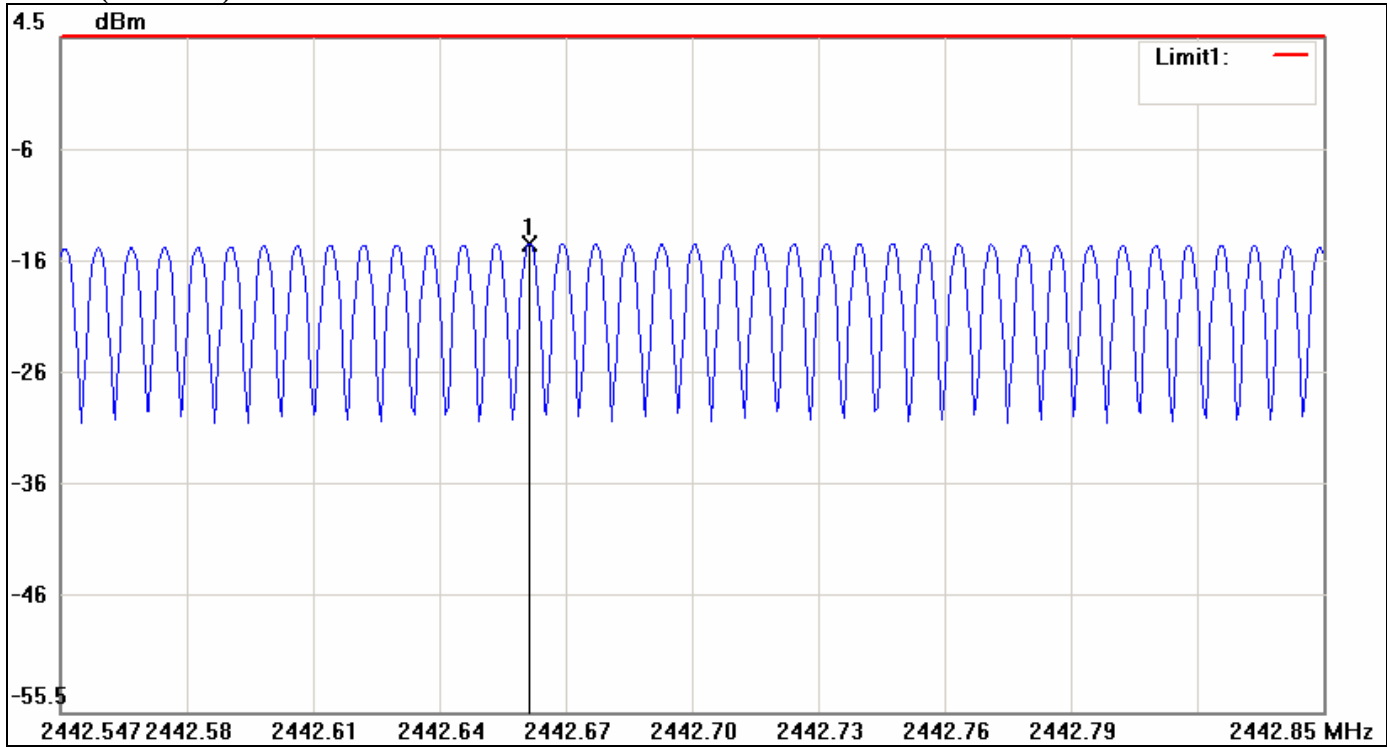

No.	Frequency(MHz)	Level(dBm)	Limit(dBm)	Margin(dBm)
1	2442.6587	-13.87	8.00	-21.87



PPSD (CH High)

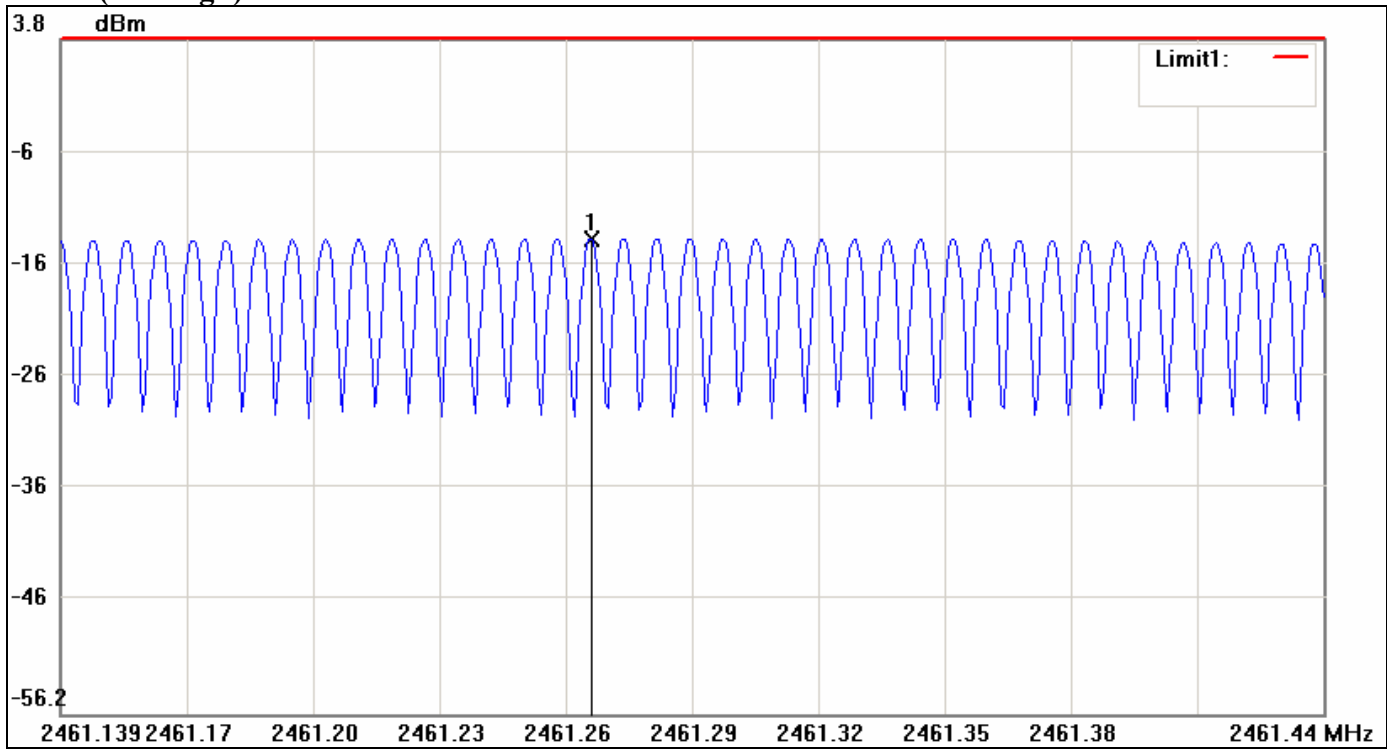

No.	Frequency(MHz)	Level(dBm)	Limit(dBm)	Margin(dBm)
1	2461.2651	-13.95	8.00	-21.95



IEEE 802.11g mode

PPSD (CH Low)

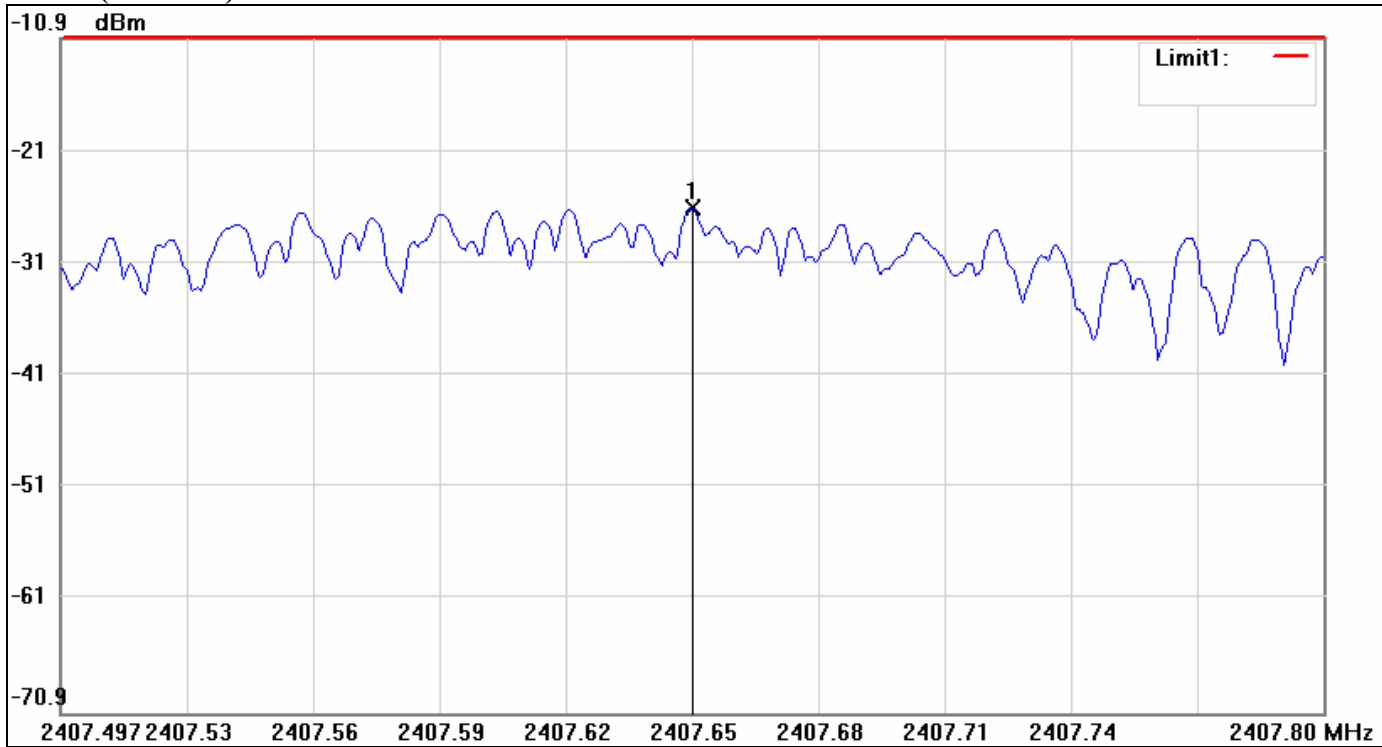

No.	Frequency(MHz)	Level(dBm)	Limit(dBm)	Margin(dBm)
1	2407.6469	-25.99	8.00	-33.99



PPSD (CH Mid)

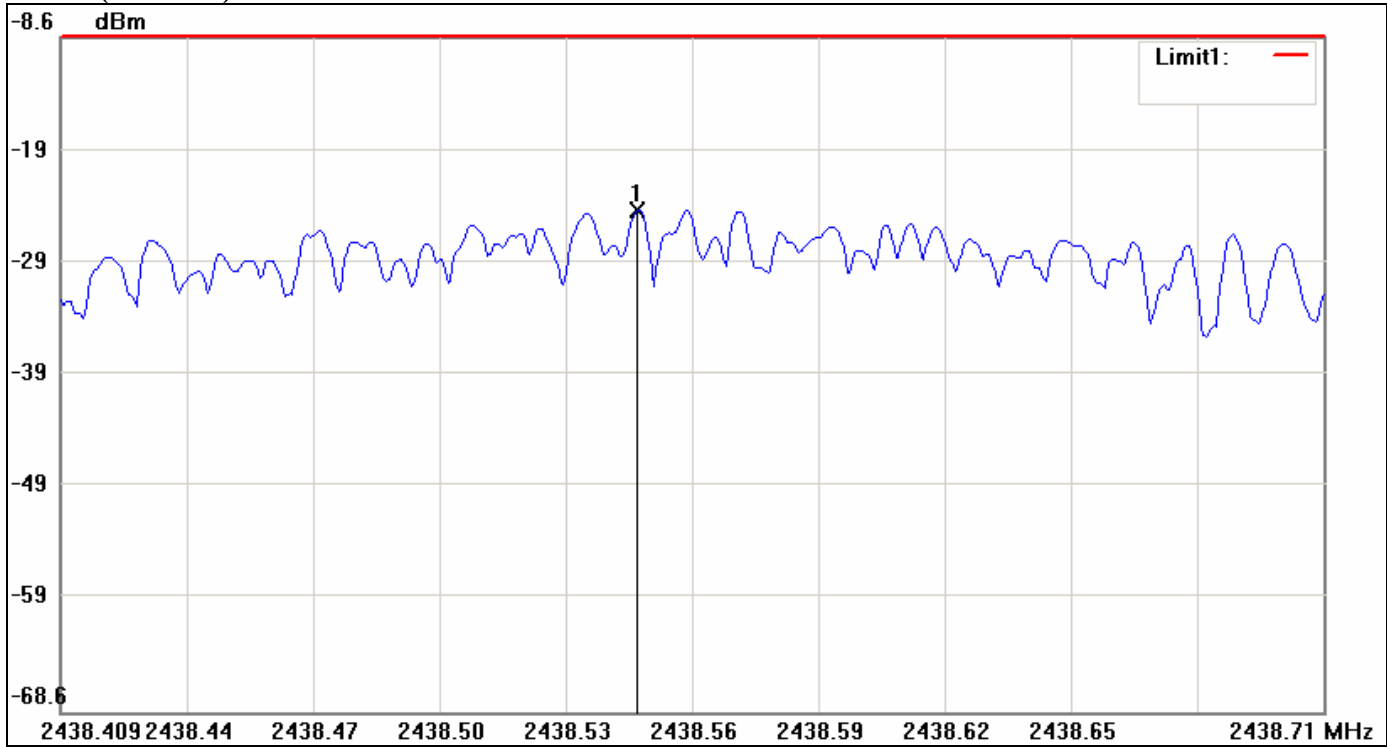

No.	Frequency(MHz)	Level(dBm)	Limit(dBm)	Margin(dBm)
1	2438.5461	-23.87	8.00	-31.87



PPSD (CH High)

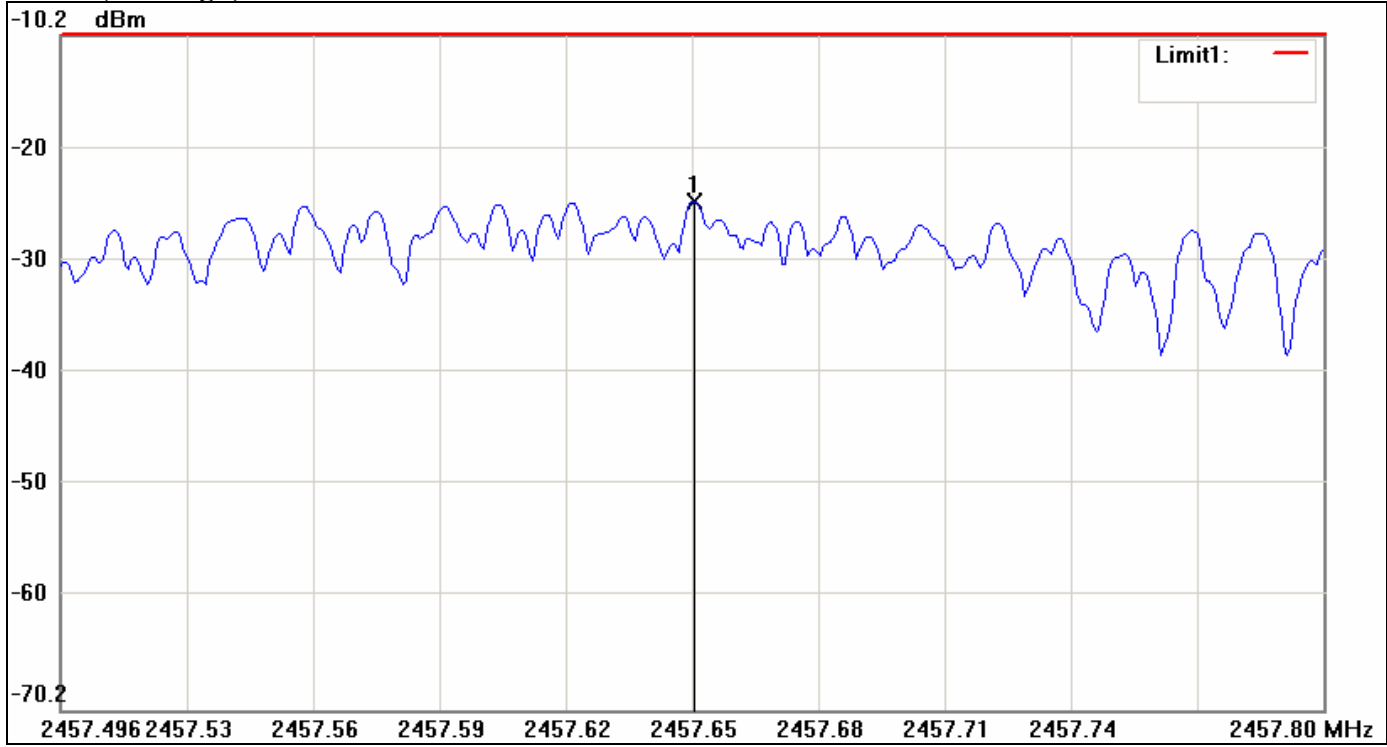

No.	Frequency(MHz)	Level(dBm)	Limit(dBm)	Margin(dBm)
1	2457.6465	-24.93	8.00	-32.93



IEEE 802.11n HT 20 MHz mode / Chain 0

PPSD (CH Low)

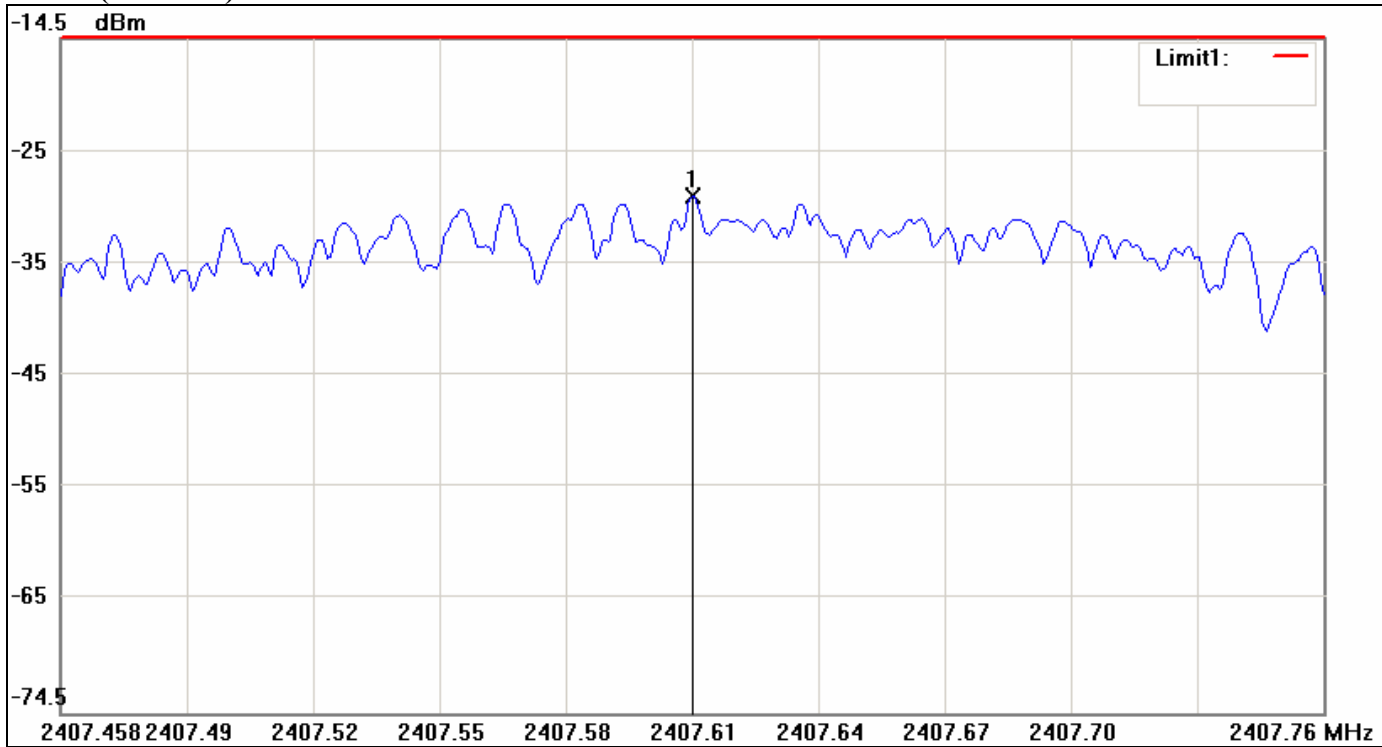

No.	Frequency(MHz)	Level(dBm)	Limit(dBm)	Margin(dBm)
1	2407.6082	-28.60	8.00	-36.60



PPSD (CH Mid)

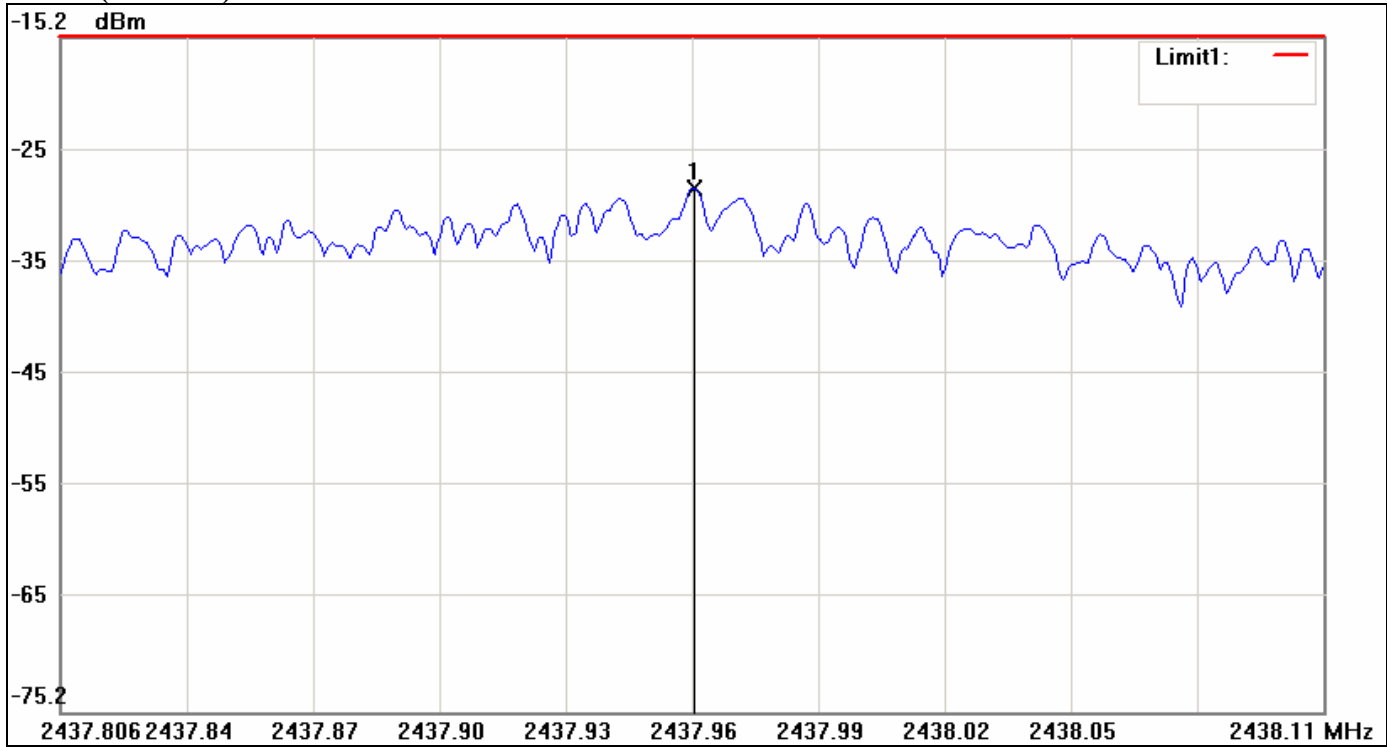

No.	Frequency(MHz)	Level(dBm)	Limit(dBm)	Margin(dBm)
1	2442.9561	-28.54	8.00	-36.54



PPSD (CH High)

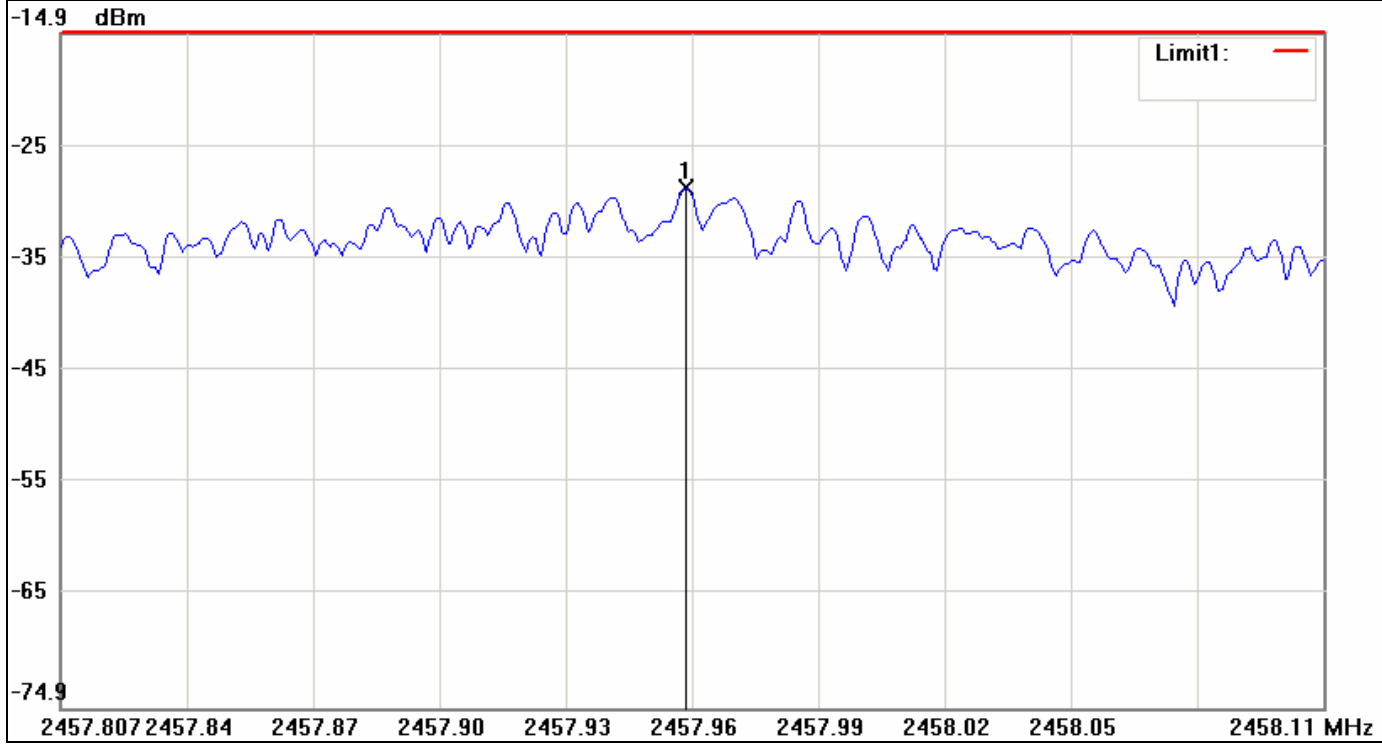

No.	Frequency(MHz)	Level(dBm)	Limit(dBm)	Margin(dBm)
1	2457.9559	-28.63	8.00	-36.63



IEEE 802.11n HT 20 MHz mode / Chain 1

PPSD (CH Low)

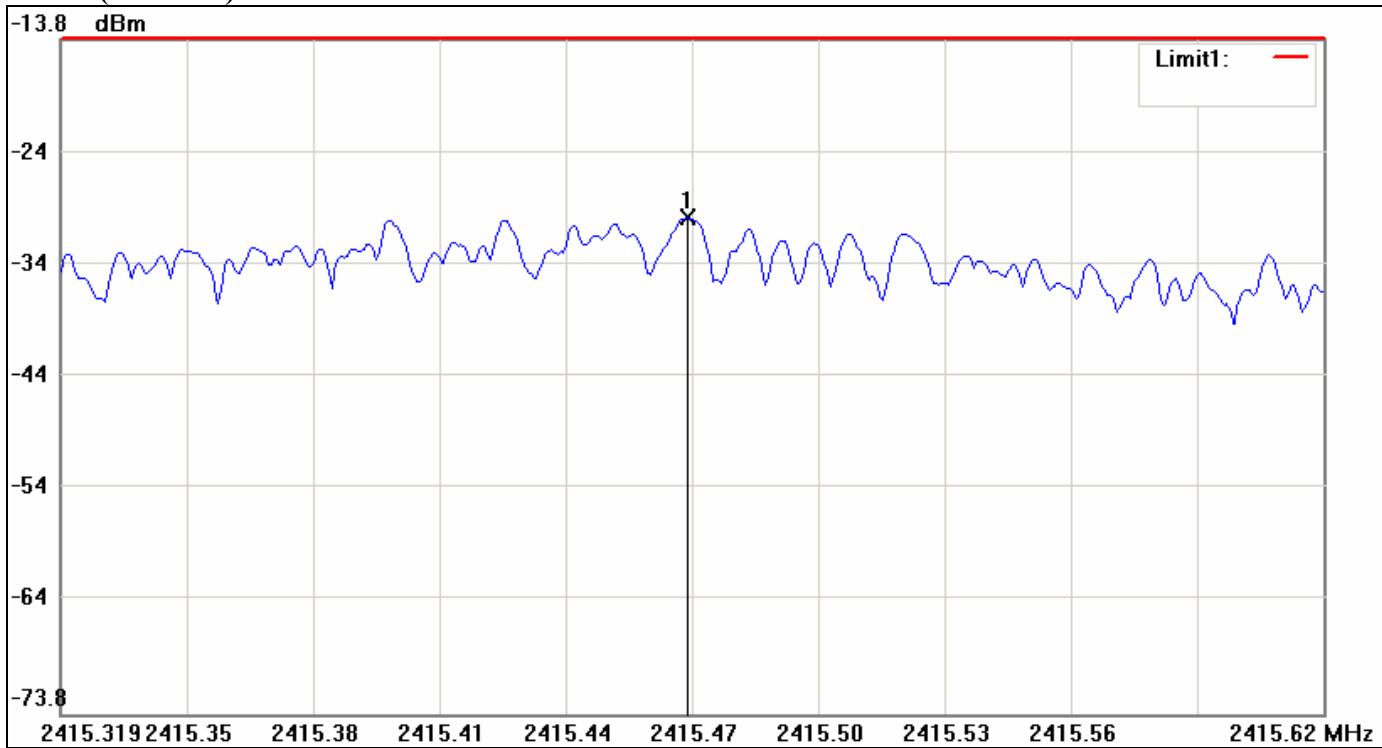

No.	Frequency(MHz)	Level(dBm)	Limit(dBm)	Margin(dBm)
1	2415.4682	-29.71	8.00	-37.71



PPSD (CH Mid)

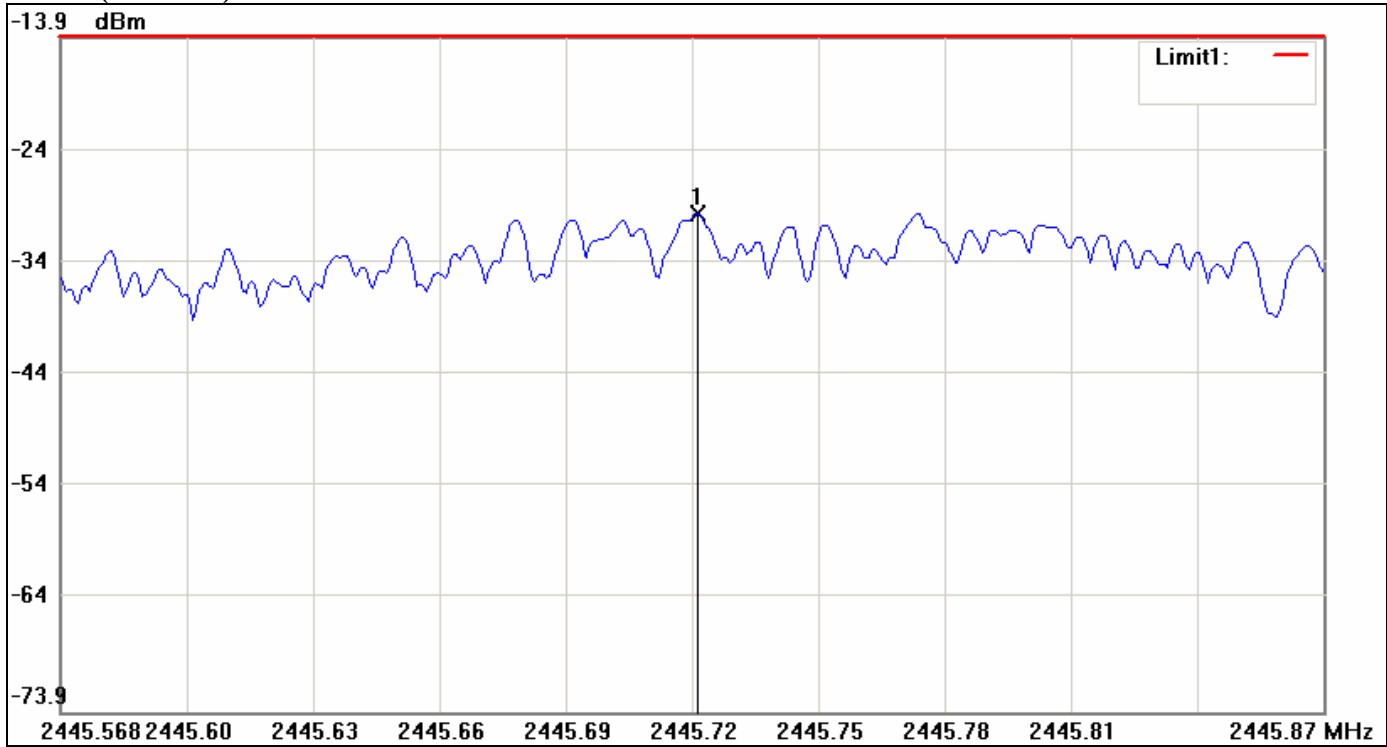

No.	Frequency(MHz)	Level(dBm)	Limit(dBm)	Margin(dBm)
1	2445.7190	-29.58	8.00	-37.58



PPSD (CH High)

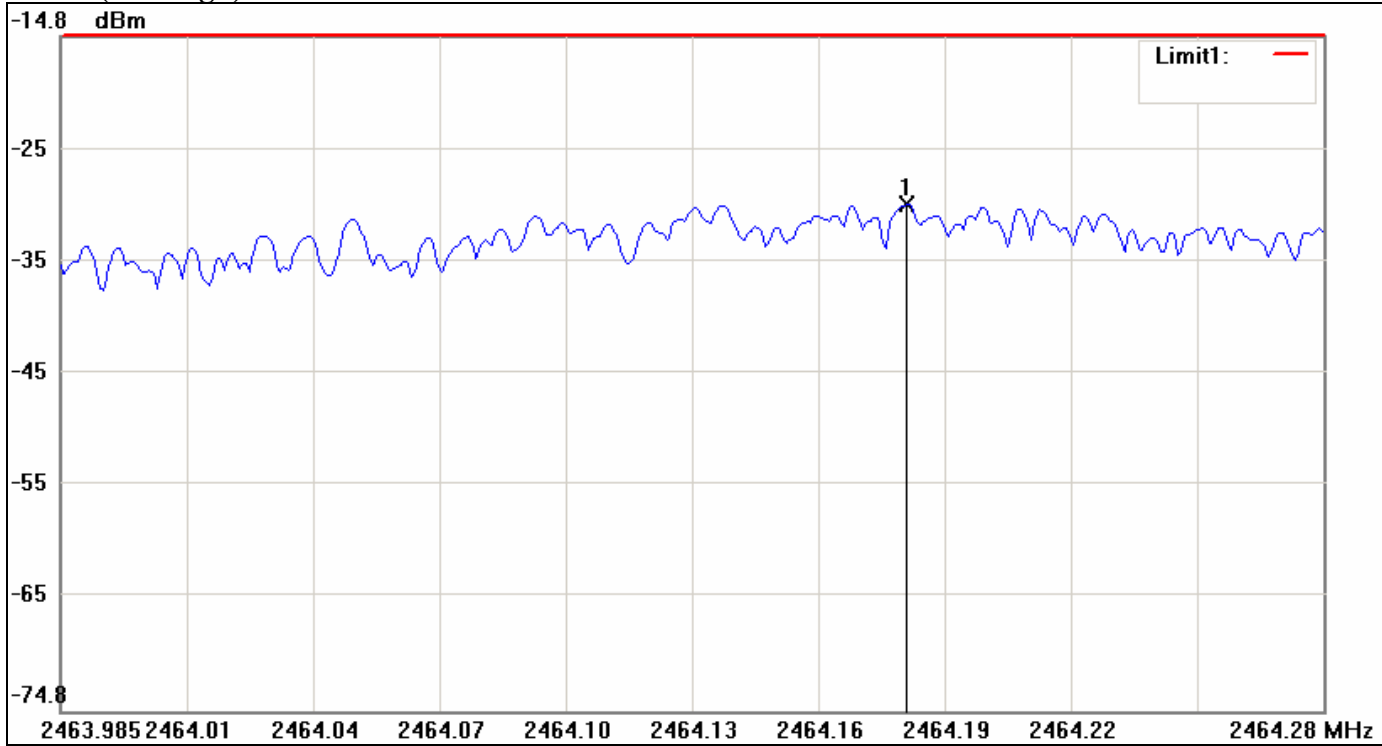

No.	Frequency(MHz)	Level(dBm)	Limit(dBm)	Margin(dBm)
1	2464.1857	-29.72	8.00	-37.72



IEEE 802.11n HT 20 MHz mode / Chain 2

PPSD (CH Low)

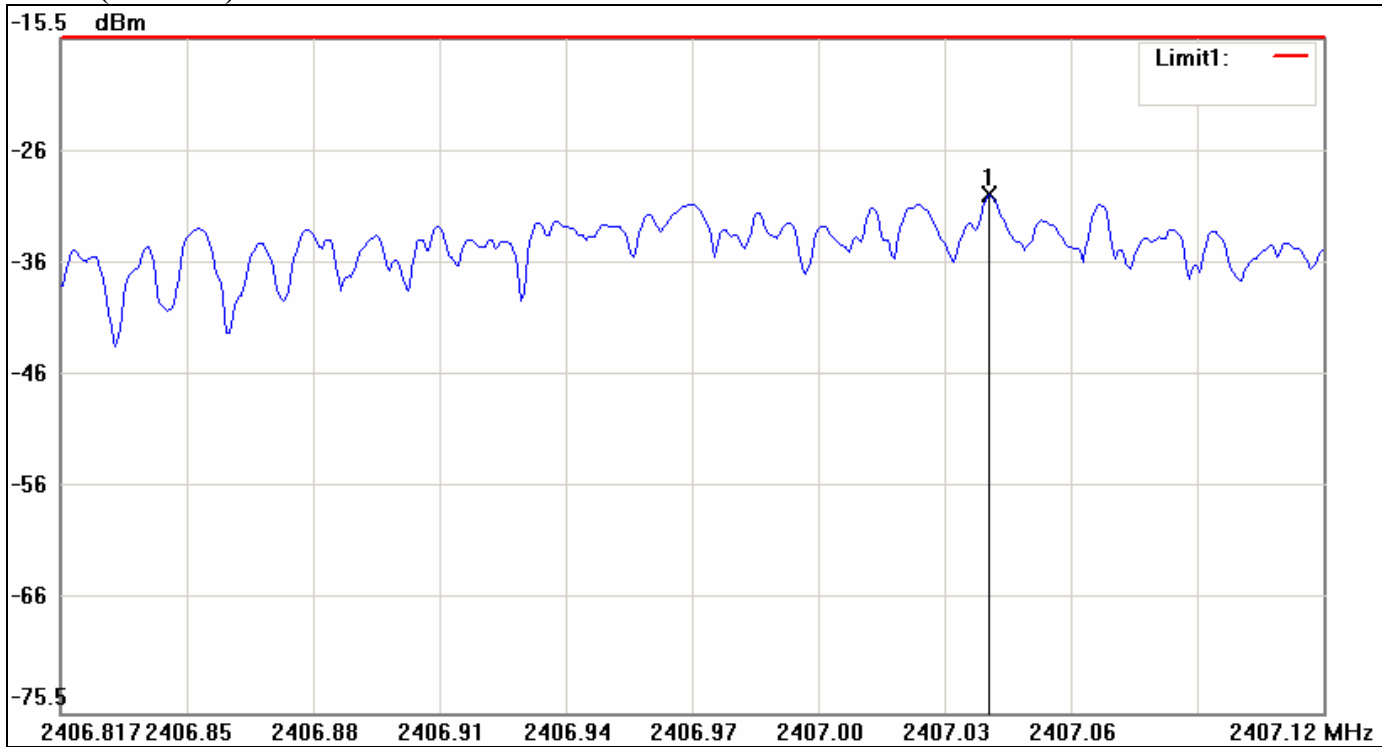

No.	Frequency(MHz)	Level(dBm)	Limit(dBm)	Margin(dBm)
1	2407.0375	-29.47	8.00	-37.47



PPSD (CH Mid)

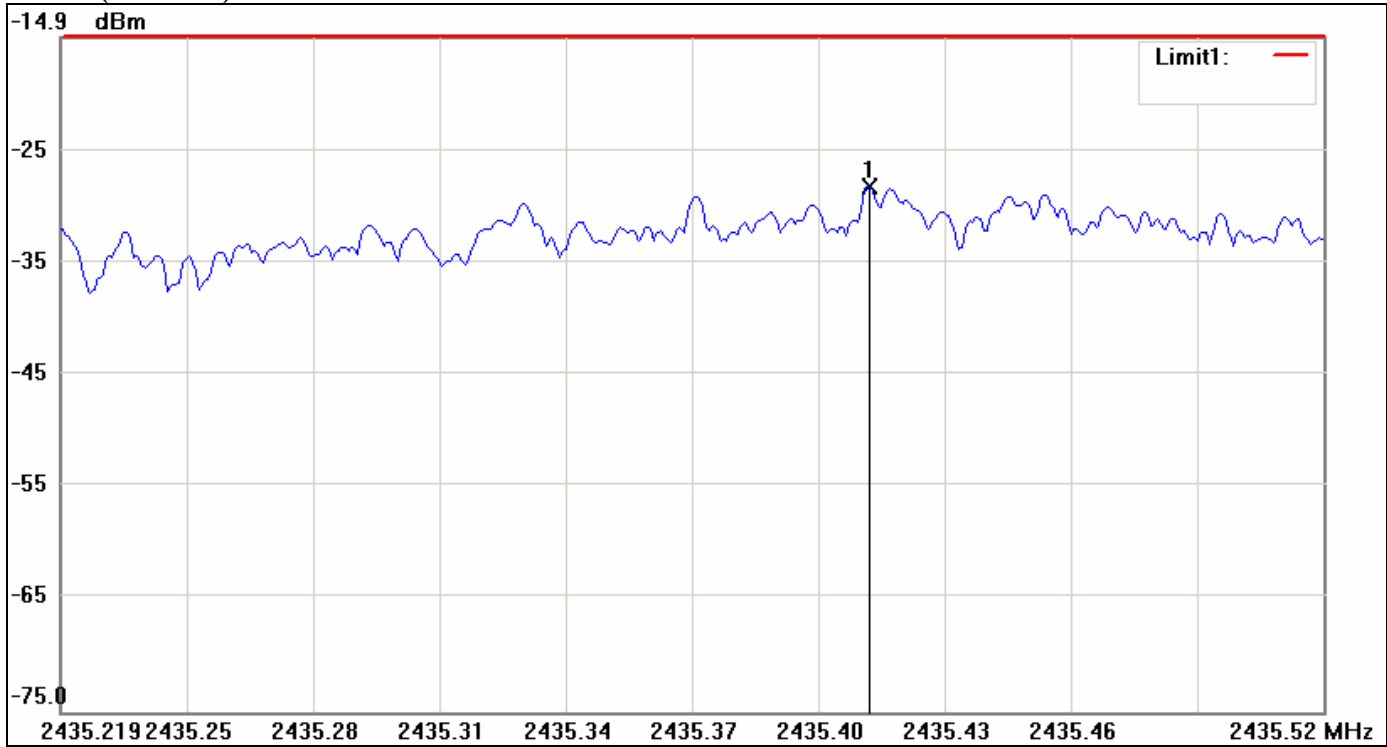

No.	Frequency(MHz)	Level(dBm)	Limit(dBm)	Margin(dBm)
1	2435.4108	-28.17	8.00	-36.17



PPSD (CH High)



No.	Frequency(MHz)	Level(dBm)	Limit(dBm)	Margin(dBm)
1	2455.4530	-28.05	8.00	-36.05



IEEE 802.11n HT 40 MHz mode / Chain 0

PPSD (CH Low)

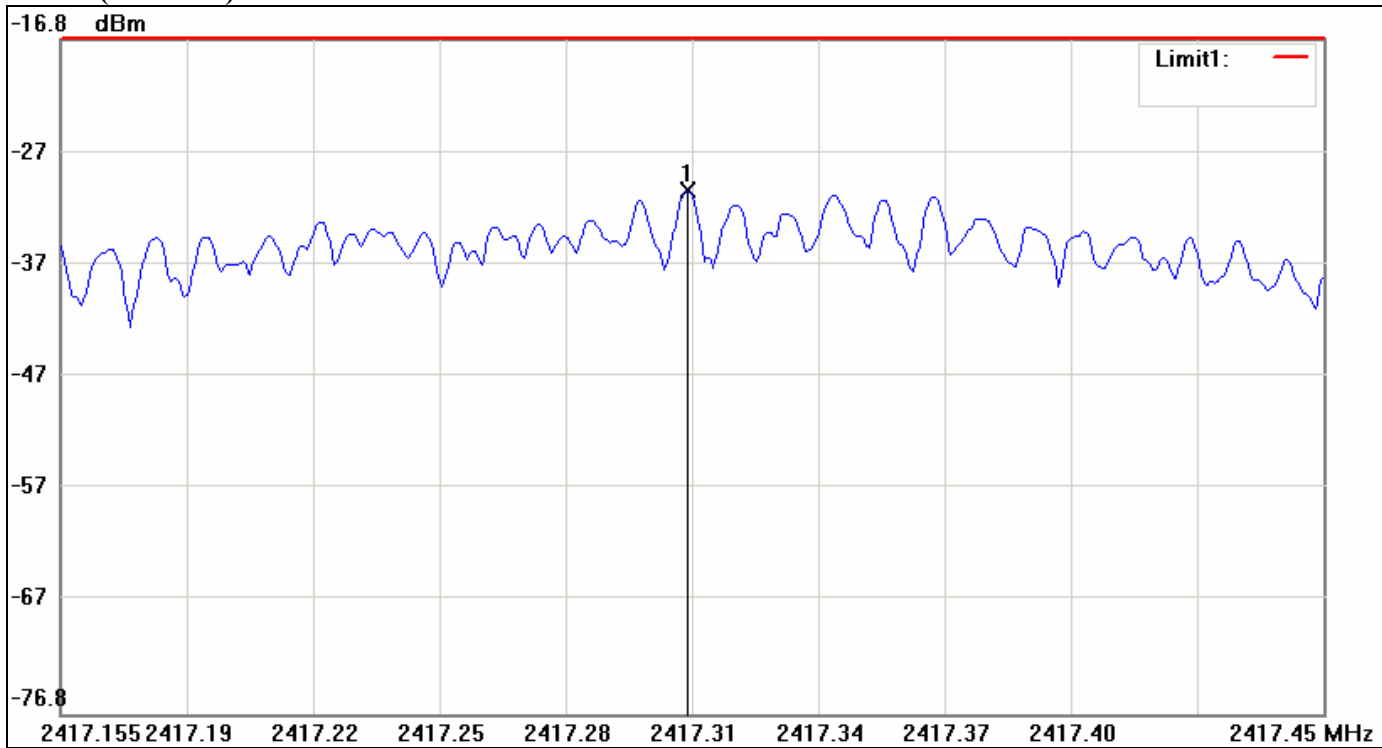

No.	Frequency(MHz)	Level(dBm)	Limit(dBm)	Margin(dBm)
1	2417.3043	-30.27	8.00	-38.27



PPSD (CH Mid)

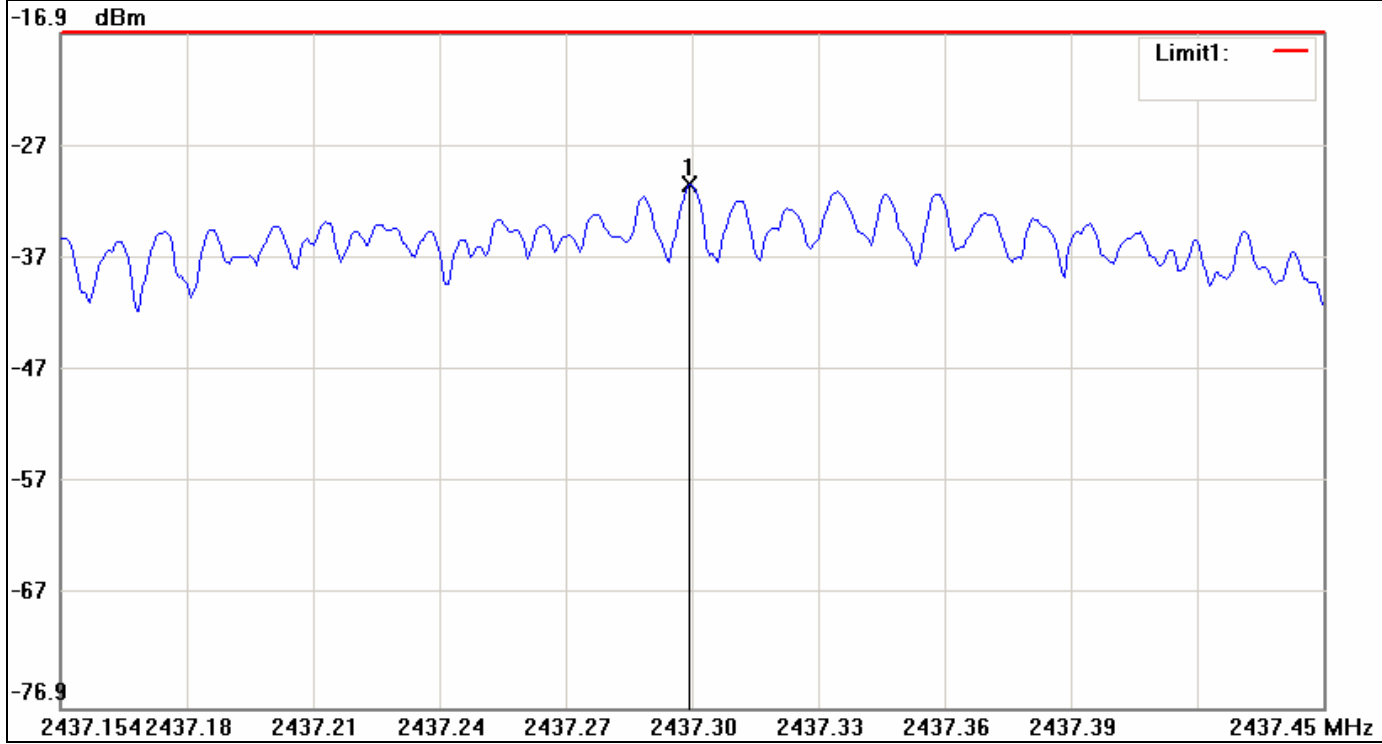

No.	Frequency(MHz)	Level(dBm)	Limit(dBm)	Margin(dBm)
1	2442.3036	-30.43	8.00	-38.43



PPSD (CH High)

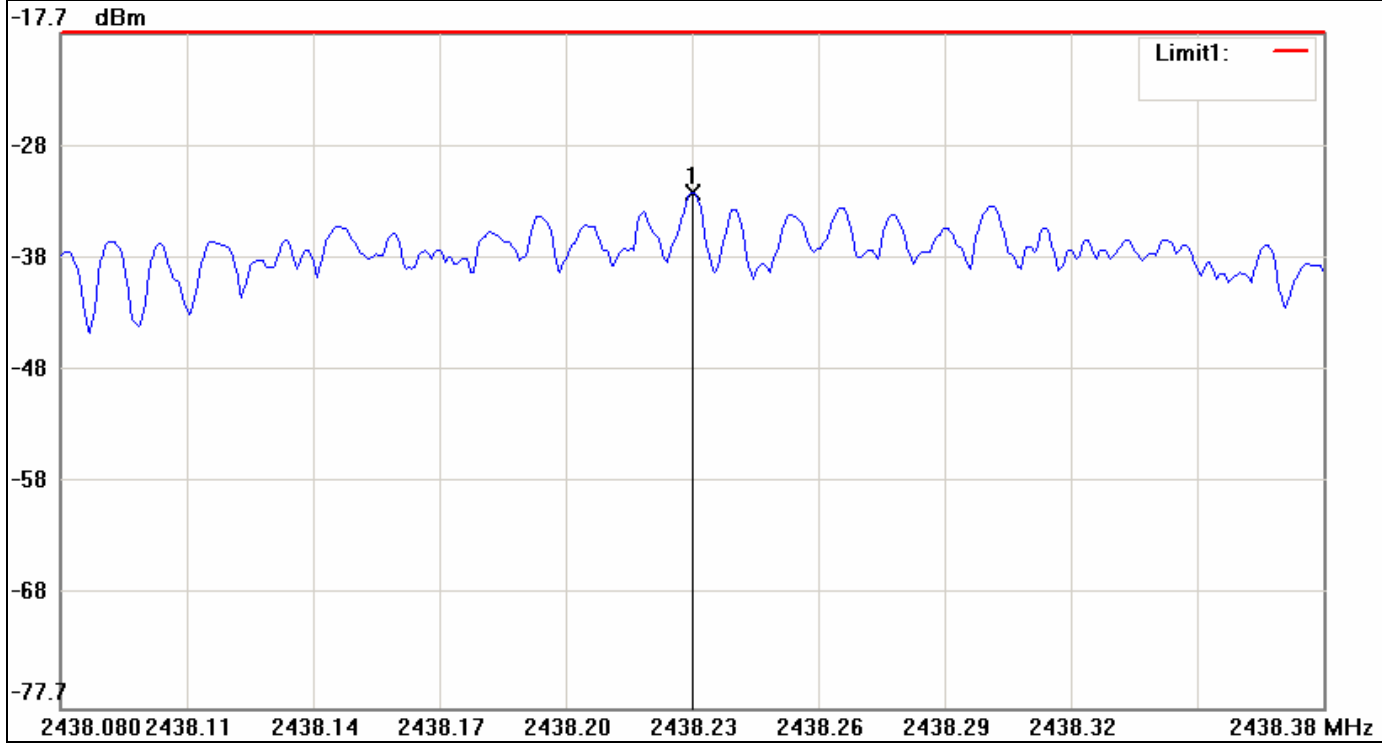

No.	Frequency(MHz)	Level(dBm)	Limit(dBm)	Margin(dBm)
1	2438.2301	-31.91	8.00	-39.91



IEEE 802.11n HT 40 MHz mode / Chain 1

PPSD (CH Low)

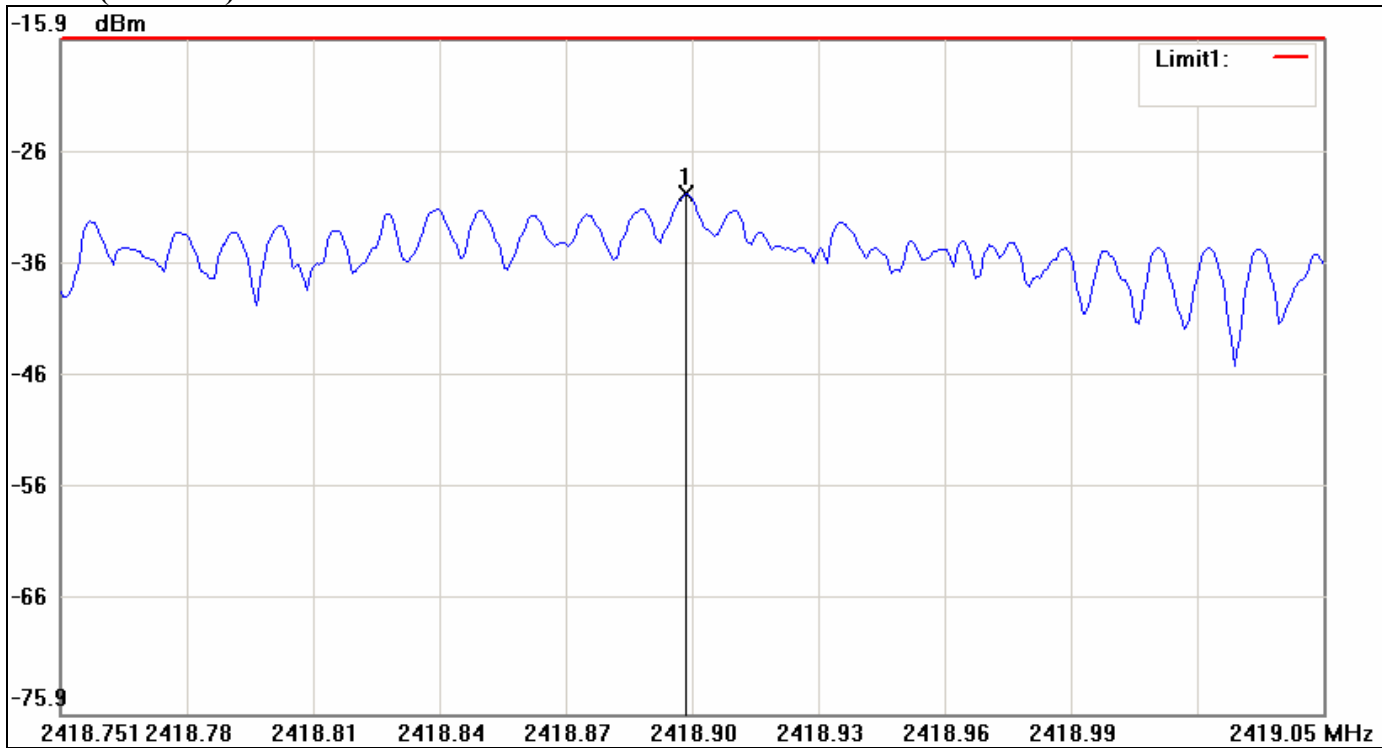

No.	Frequency(MHz)	Level(dBm)	Limit(dBm)	Margin(dBm)
1	2418.8999	-29.66	8.00	-37.66



PPSD (CH Mid)

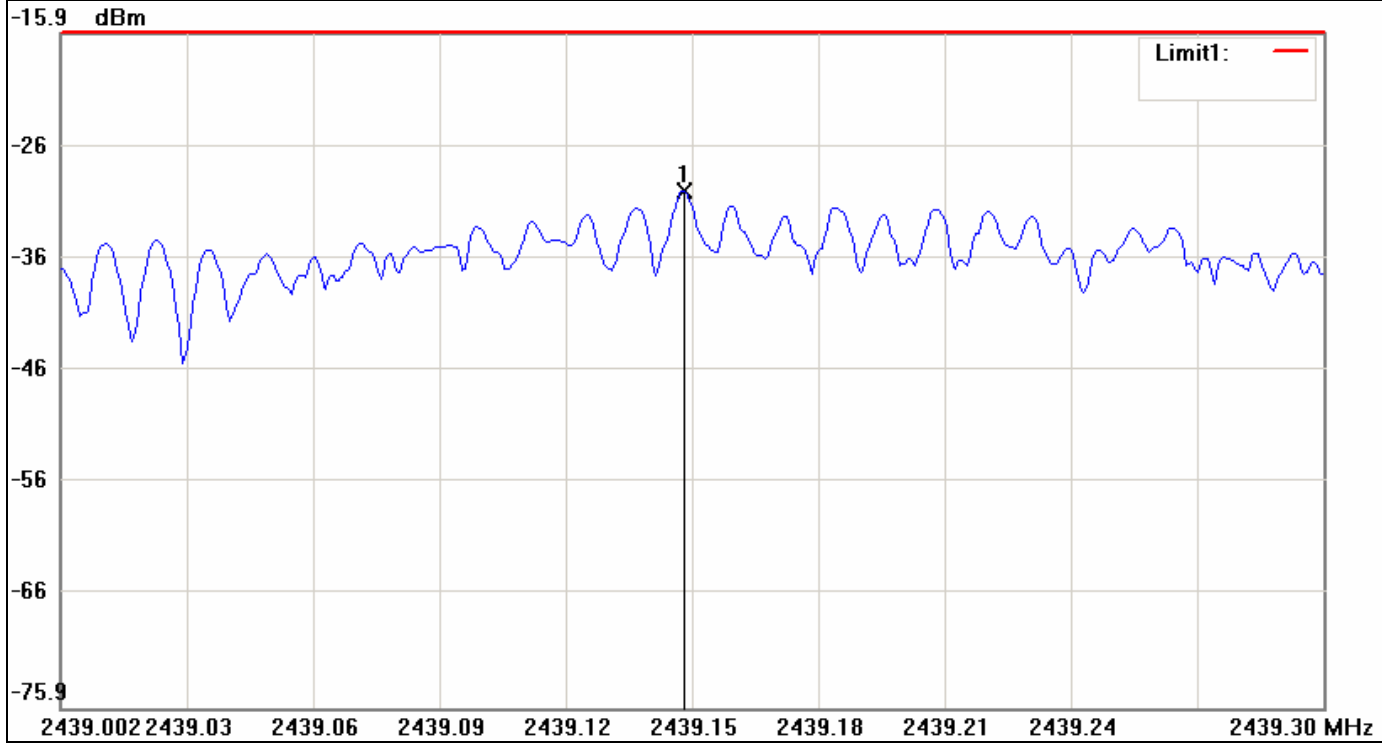

No.	Frequency(MHz)	Level(dBm)	Limit(dBm)	Margin(dBm)
1	2439.1501	-29.91	8.00	-37.91



PPSD (CH High)

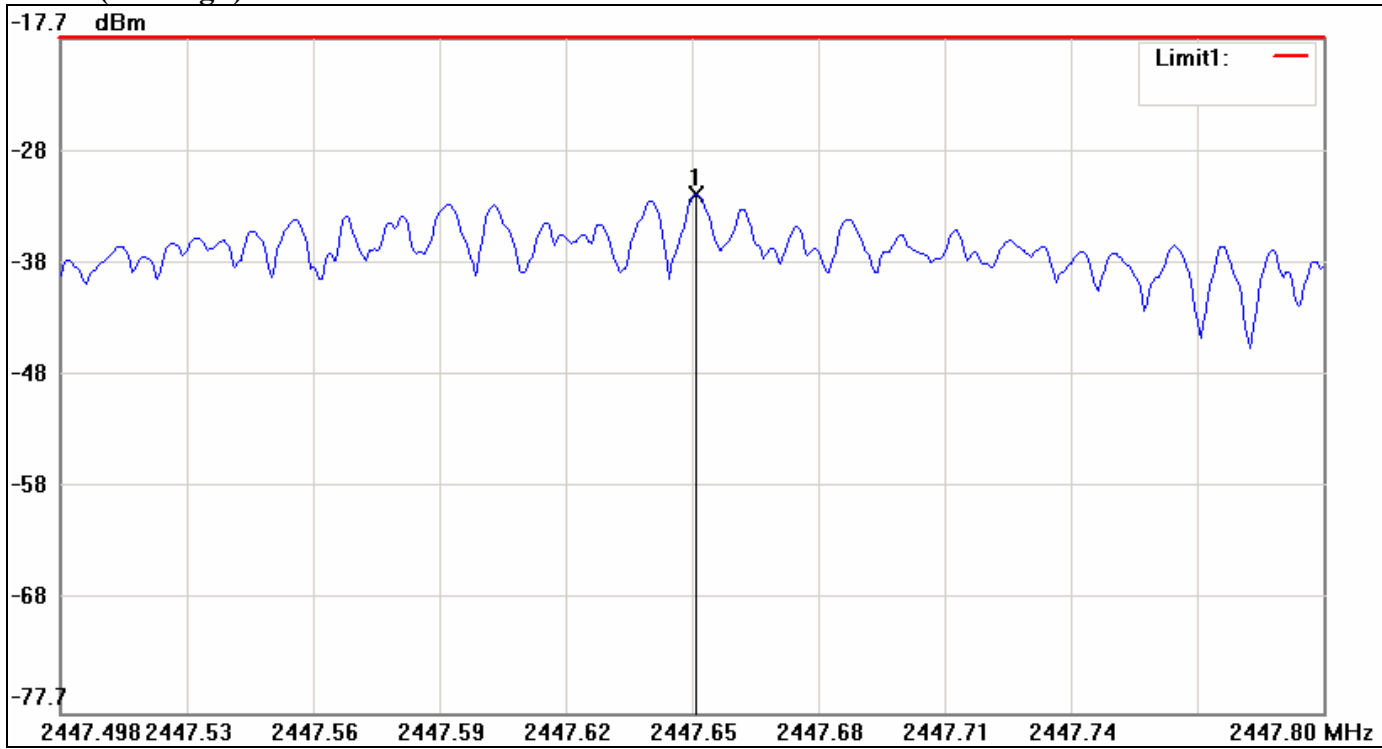

No.	Frequency(MHz)	Level(dBm)	Limit(dBm)	Margin(dBm)
1	2447.6487	-31.57	8.00	-39.57



IEEE 802.11n HT 40 MHz mode / Chain 2

PPSD (CH Low)

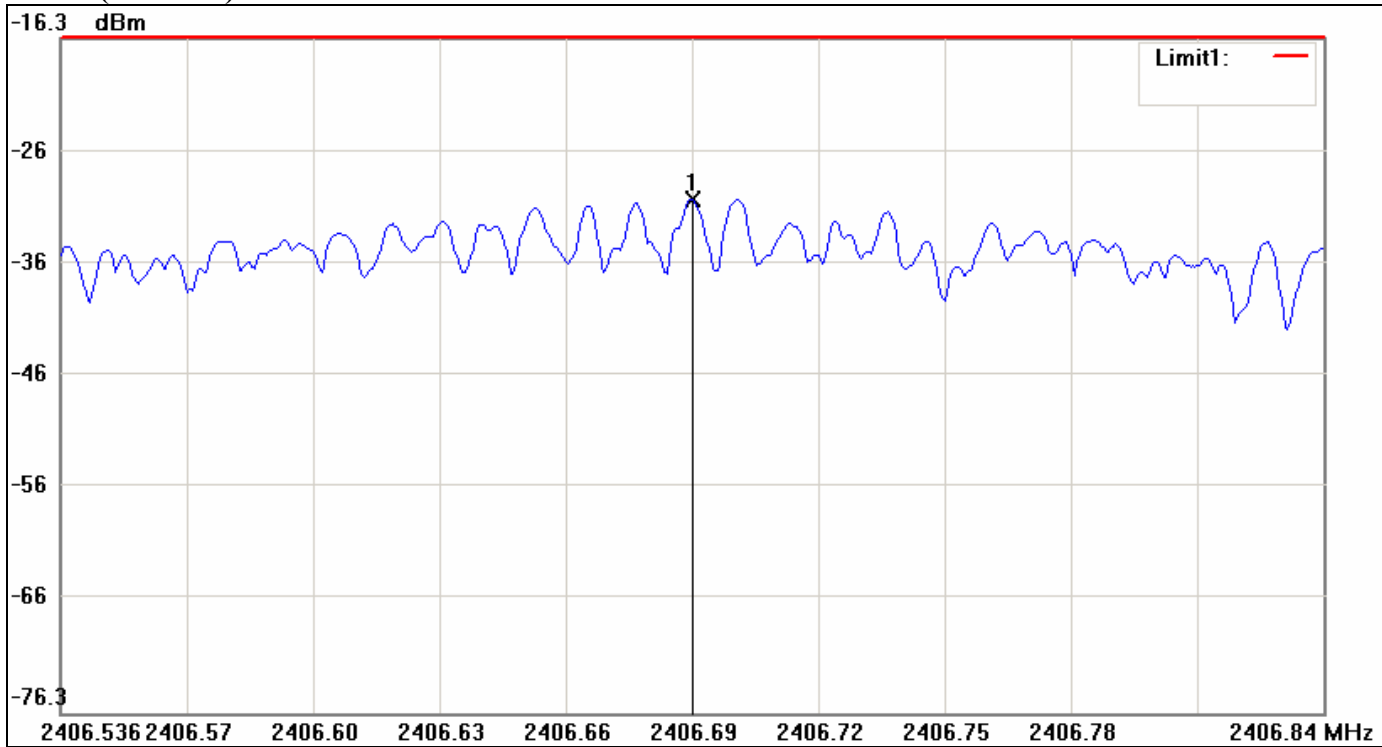

No.	Frequency(MHz)	Level(dBm)	Limit(dBm)	Margin(dBm)
1	2406.6862	-30.69	8.00	-38.69



PPSD (CH Mid)

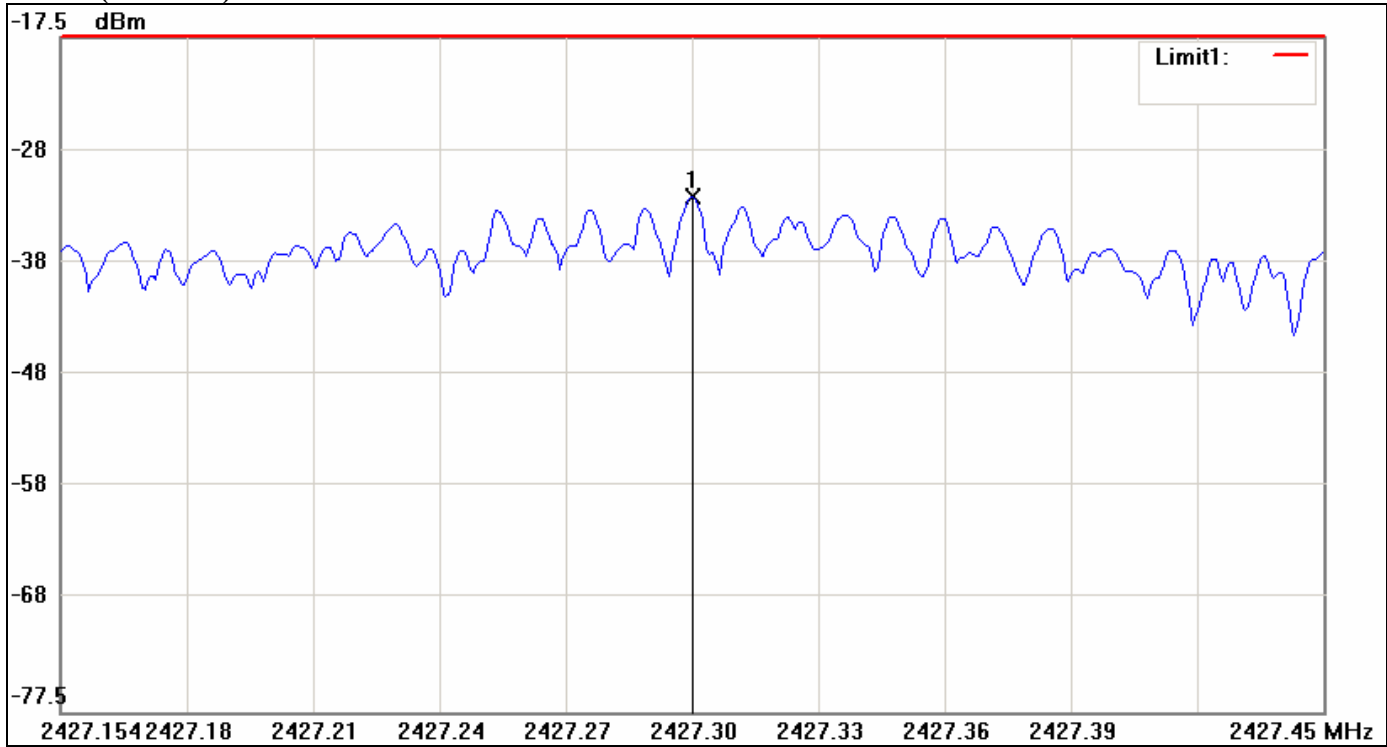

No.	Frequency(MHz)	Level(dBm)	Limit(dBm)	Margin(dBm)
1	2427.3044	-31.73	8.00	-39.73



PPSD (CH High)

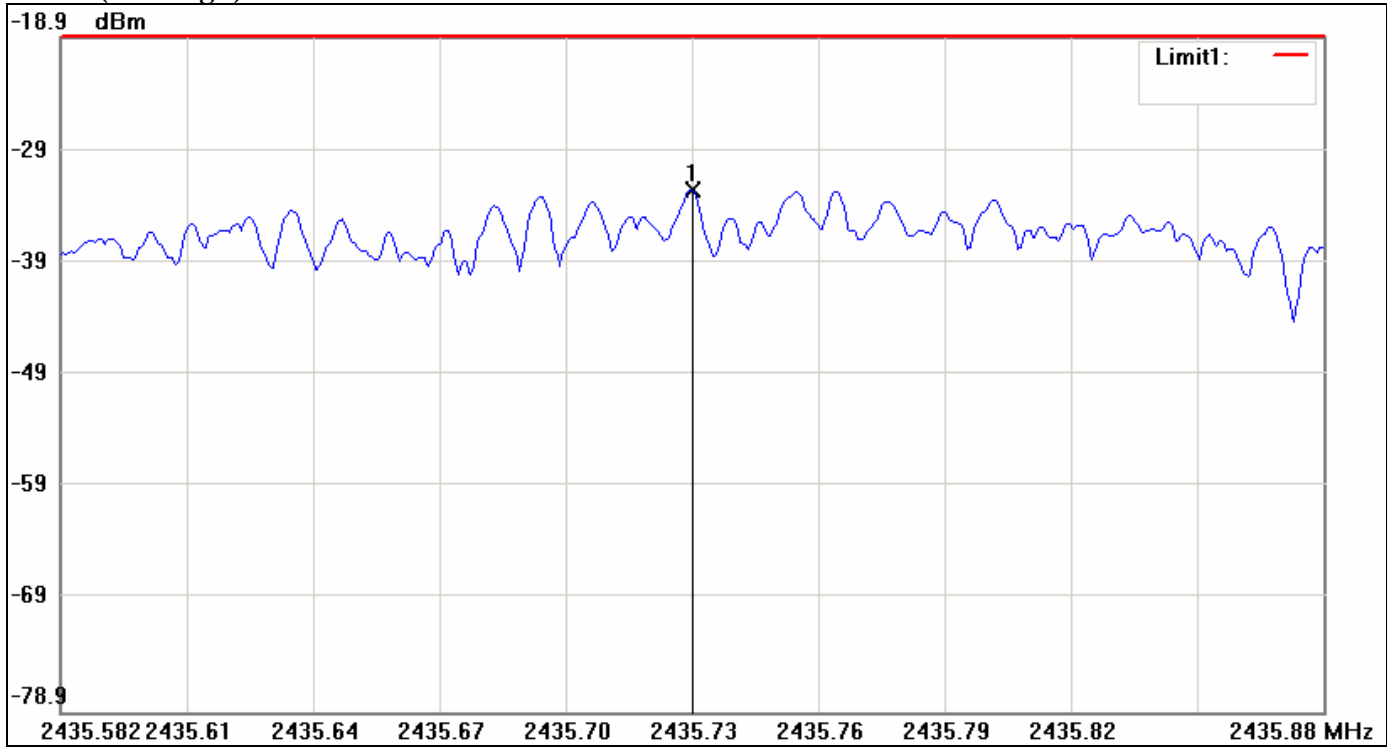

No.	Frequency(MHz)	Level(dBm)	Limit(dBm)	Margin(dBm)
1	2435.7323	-32.45	8.00	-40.45



IEEE 802.11n HT 20 MHz mode with combiner

PPSD (CH Low)

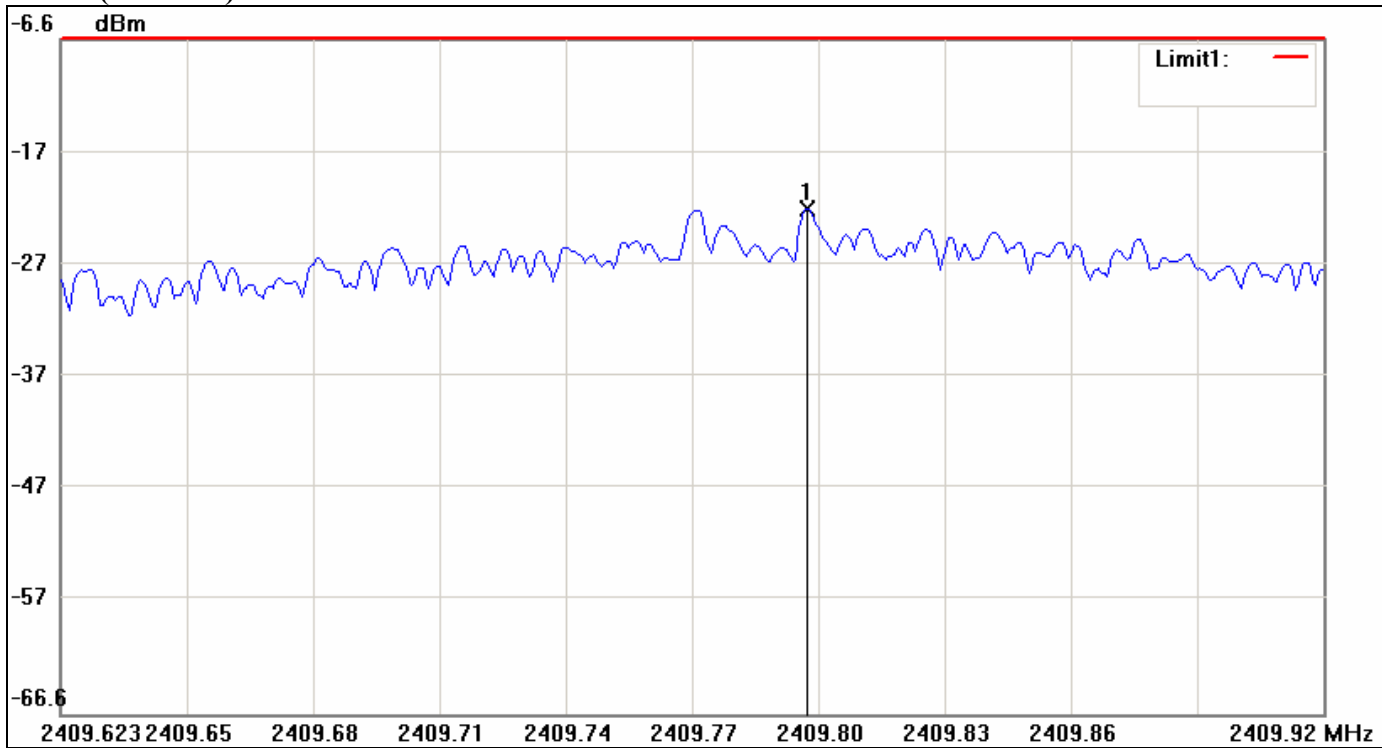

No.	Frequency(MHz)	Level(dBm)	Limit(dBm)	Margin(dBm)
1	2409.8008	-21.72	8.00	-29.72



PPSD (CH Mid)

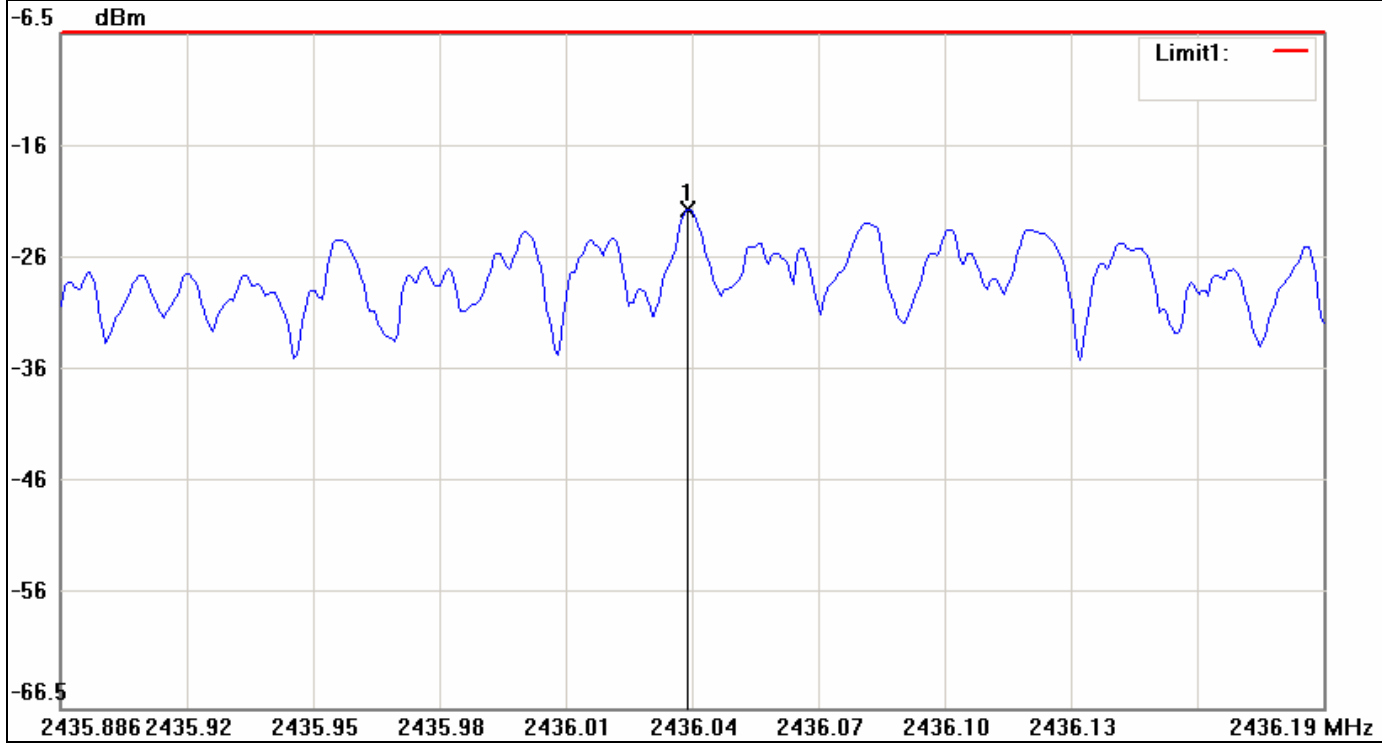

No.	Frequency(MHz)	Level(dBm)	Limit(dBm)	Margin(dBm)
1	2436.0352	-22.13	8.00	-30.13



PPSD (CH High)

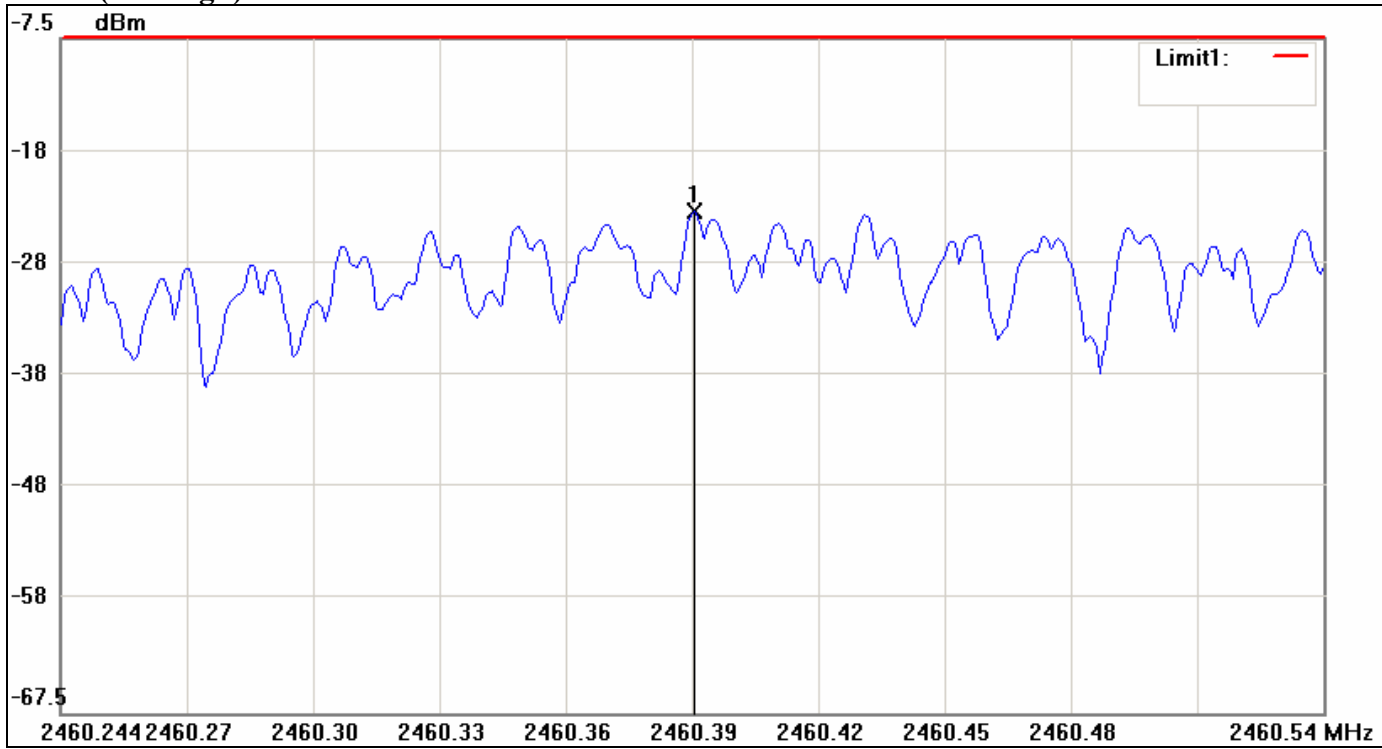

No.	Frequency(MHz)	Level(dBm)	Limit(dBm)	Margin(dBm)
1	2460.3941	-22.95	8.00	-30.95



IEEE 802.11n HT 40 MHz mode with combiner

PPSD (CH Low)

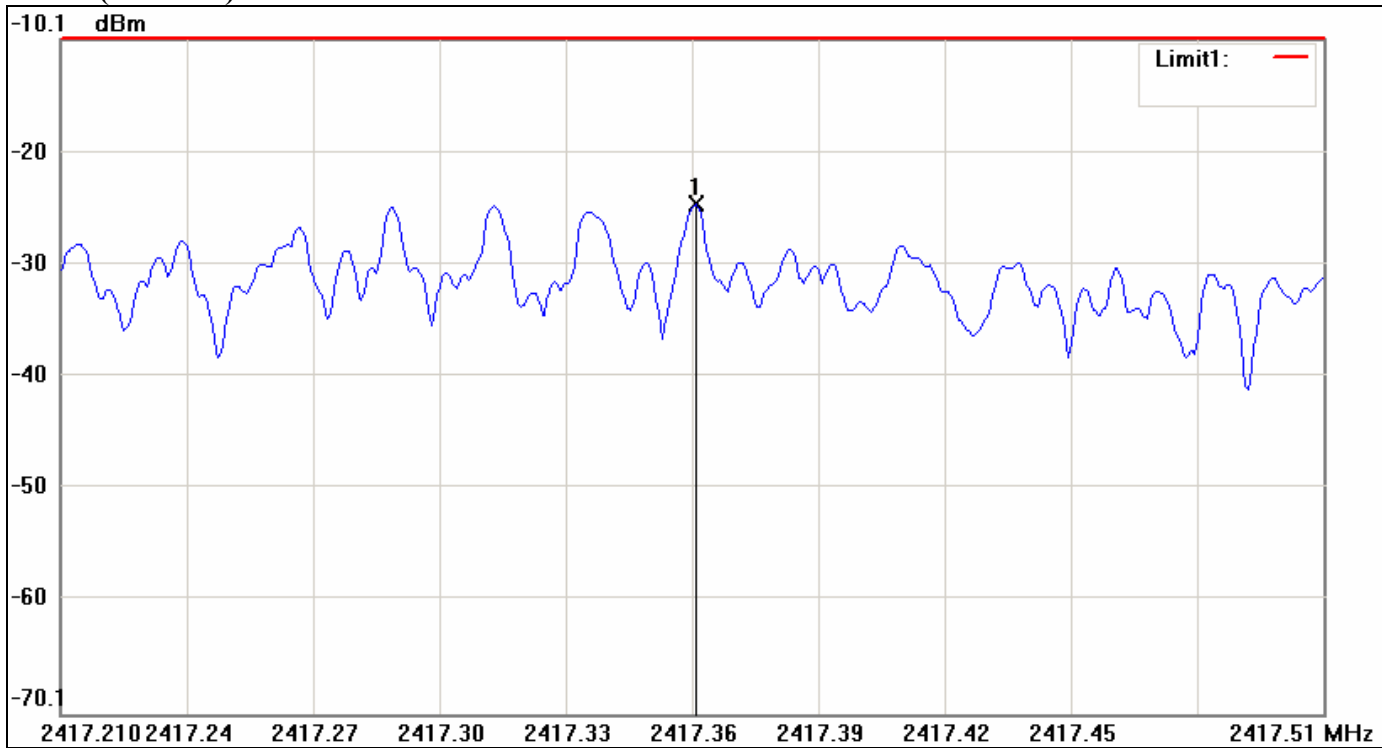

No.	Frequency(MHz)	Level(dBm)	Limit(dBm)	Margin(dBm)
1	2417.3612	-24.75	8.00	-32.75



PPSD (CH Mid)

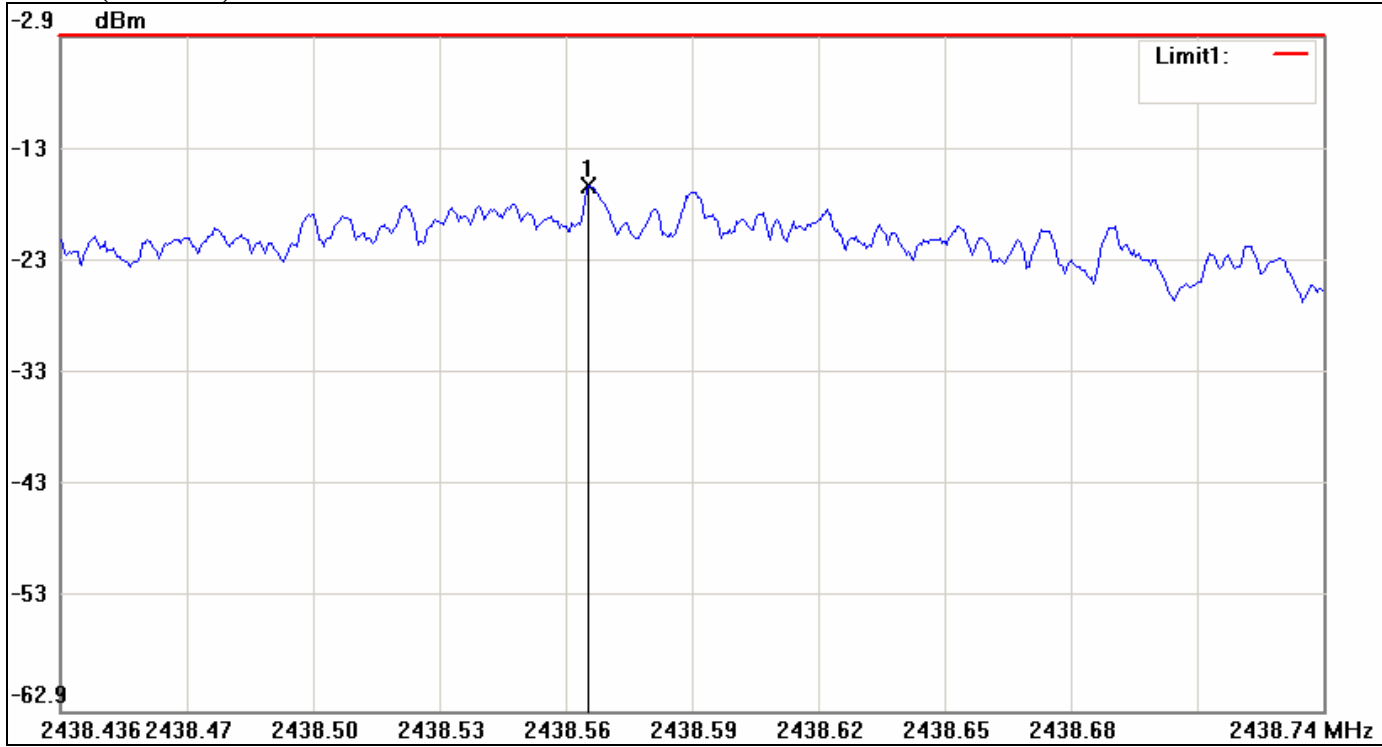

No.	Frequency(MHz)	Level(dBm)	Limit(dBm)	Margin(dBm)
1	2438.5614	-16.22	8.00	-24.22



PPSD (CH High)

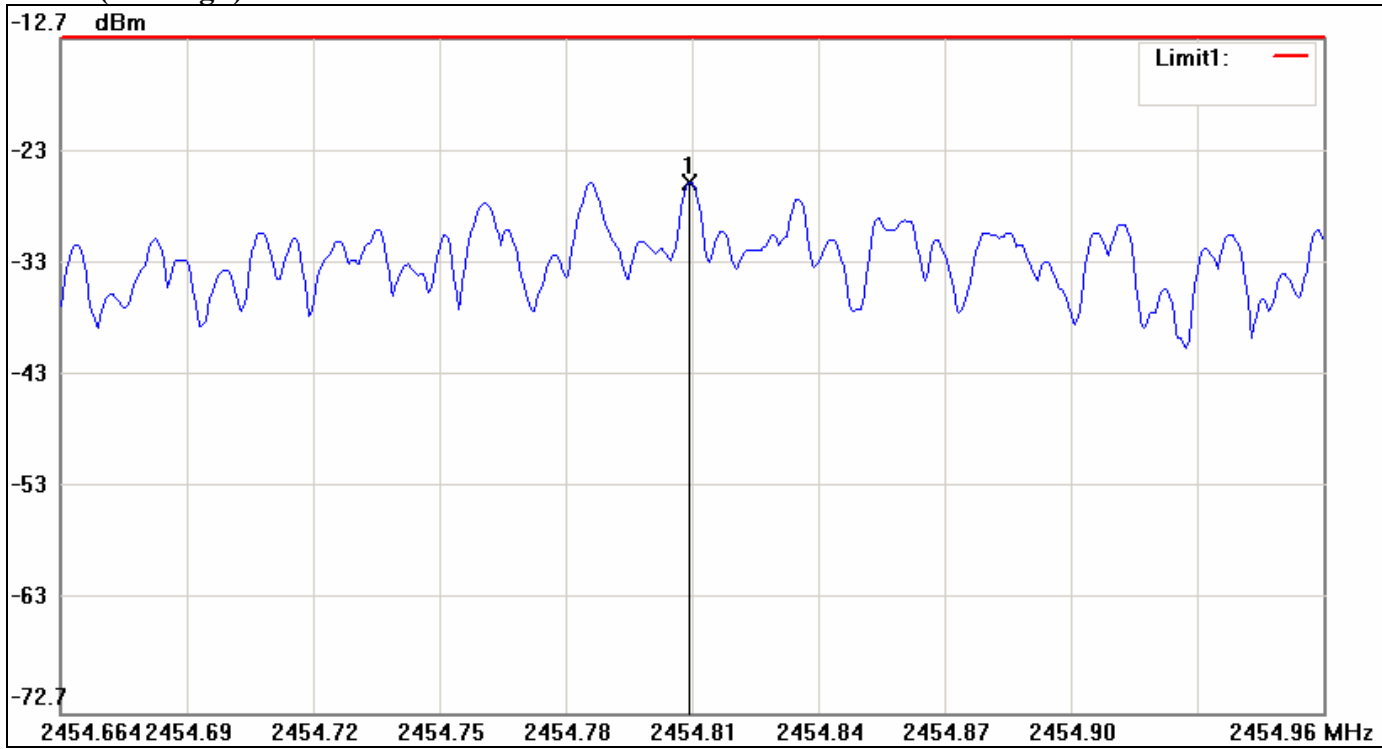

No.	Frequency(MHz)	Level(dBm)	Limit(dBm)	Margin(dBm)
1	2454.8136	-25.54	8.00	-33.54



7.6 SPURIOUS EMISSIONS

7.6.1 Conducted Measurement

LIMIT

According to §15.247(d), in any 100 kHz bandwidth outside the frequency bands in which the spread spectrum intentional radiator is operating, the radio frequency power that is produced by the intentional radiator shall be at least 20 dB below that in the 100 kHz bandwidth within the band that contains the highest level of the desired power, based on either an RF conducted or a radiated measurement, provided the transmitter demonstrates compliance with the peak conducted power limits. In addition, radiated emissions which fall in the restricted bands, as defined in §15.205(a), must also comply with the radiated emission limits specified in 15.209(a) (see Section 15.205(c)).

Test Configuration

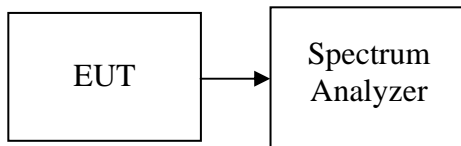

TEST PROCEDURE

Conducted RF measurements of the transmitter output were made to confirm that the EUT antenna port conducted emissions meet the specified limit and to identify any spurious signals that require further investigation or measurements on the radiated emissions site.

The transmitter output is connected to the spectrum analyzer. The resolution bandwidth is set to 100 kHz. The video bandwidth is set to 100 kHz.

Measurements are made over the 30MHz to 26GHz range with the transmitter set to the lowest, middle, and highest channels.

TEST RESULTS

No non-compliance noted



Test Plot

IEEE 802.11b mode

CH Low

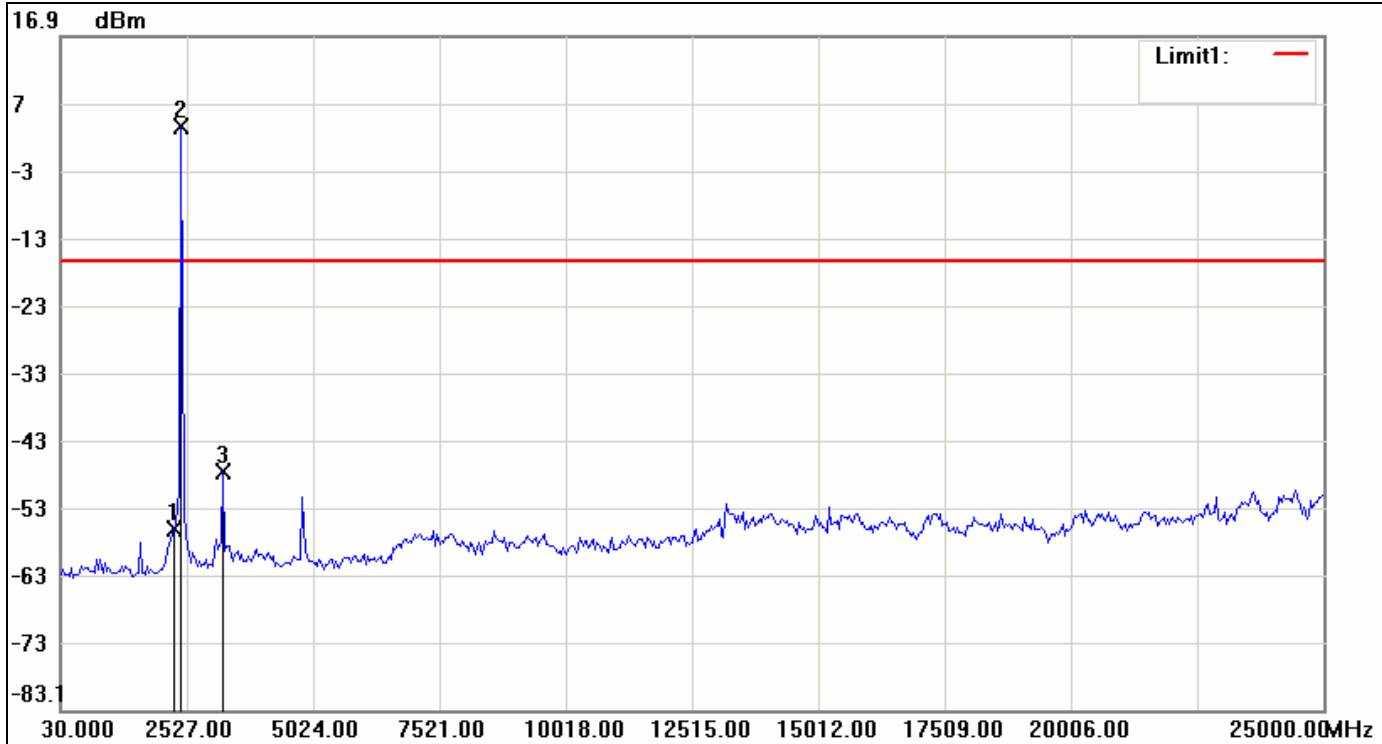

No.	Frequency(MHz)	Level(dBm)	Limit(dBm)	Margin(dBm)
1	2277.3000	-56.10	-16.37	-39.73
2	2402.1500	3.63	-16.37	20.00
3	3234.4833	-47.62	-16.37	-31.25



CH Mid

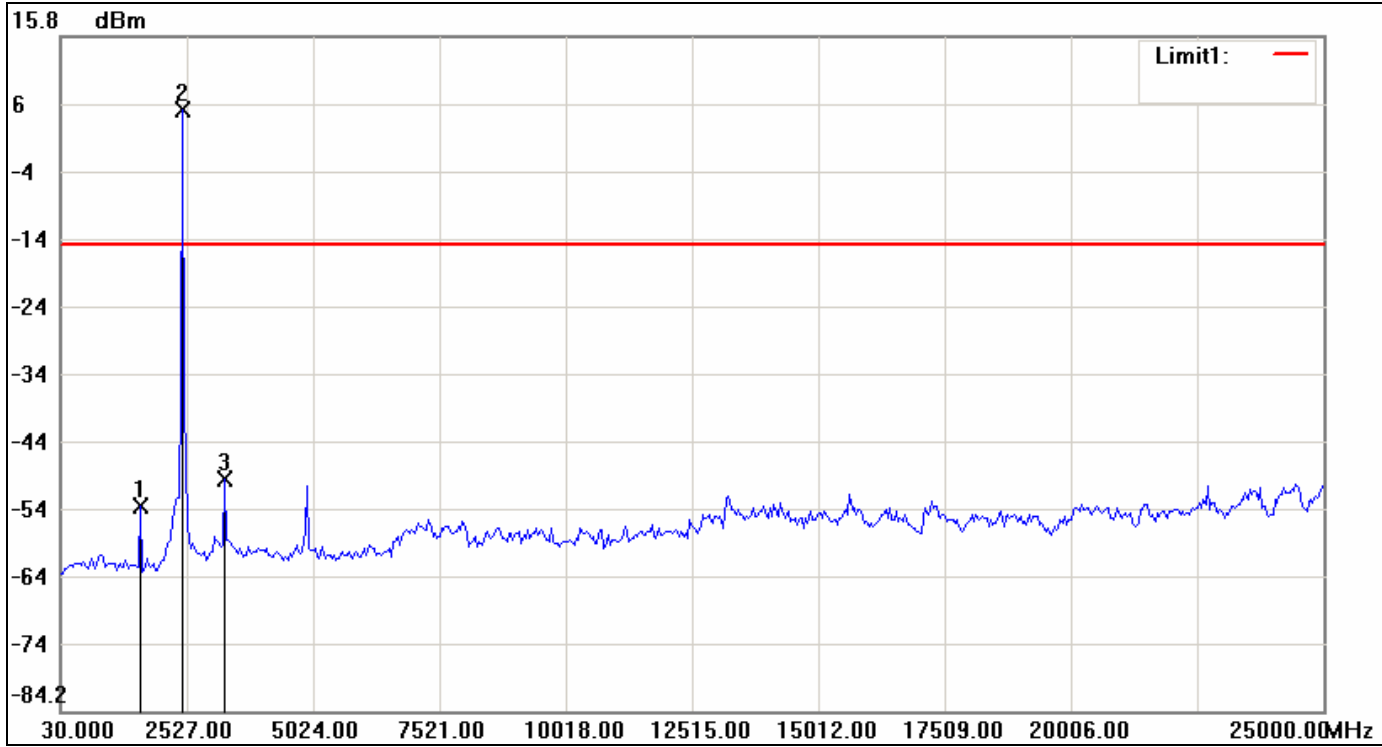

No.	Frequency(MHz)	Level(dBm)	Limit(dBm)	Margin(dBm)
1	1611.4333	-53.88	-15.03	-38.85
2	2443.7667	4.97	-15.03	20.00
3	3276.1000	-49.91	-15.03	-34.88



CH High

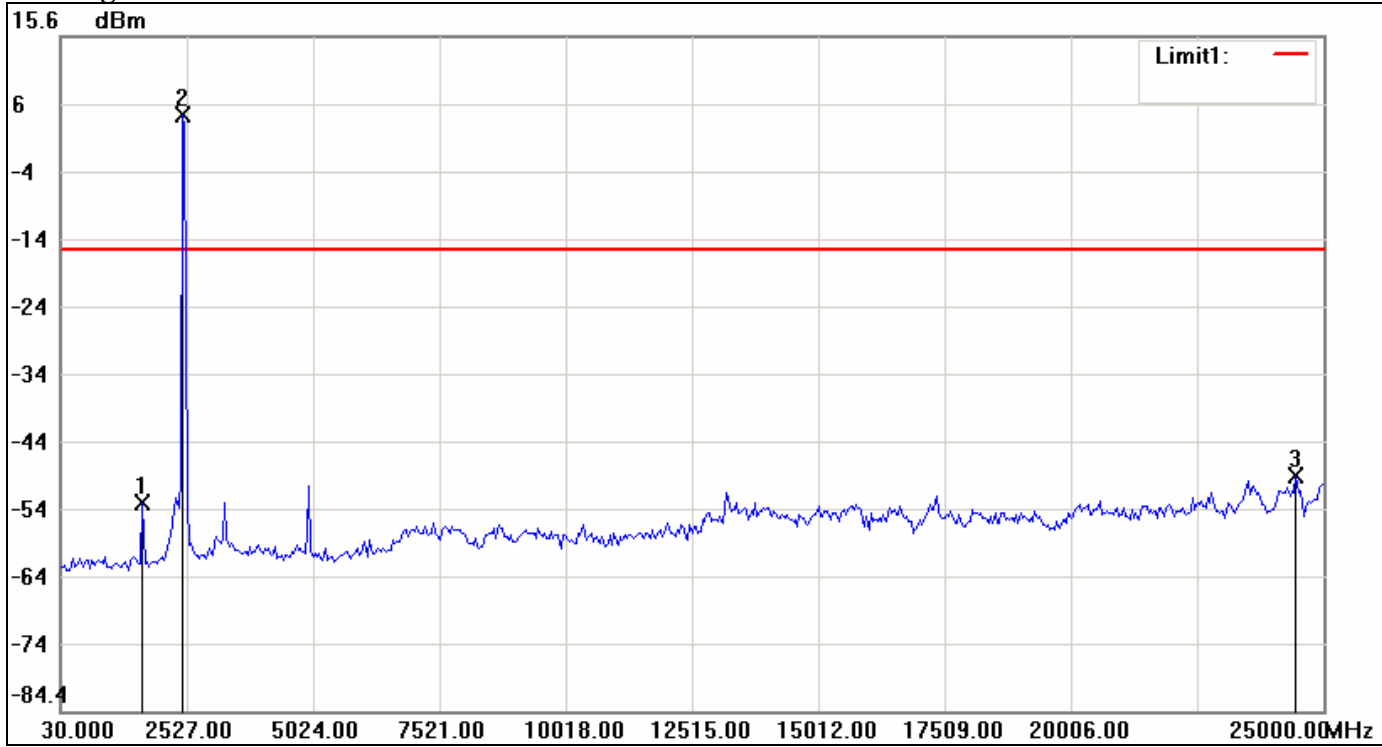

No.	Frequency(MHz)	Level(dBm)	Limit(dBm)	Margin(dBm)
1	1653.0500	-53.48	-16.02	-37.46
2	2443.7667	3.98	-16.02	20.00
3	24458.9833	-49.59	-16.02	-33.57



IEEE 802.11g mode

CH Low

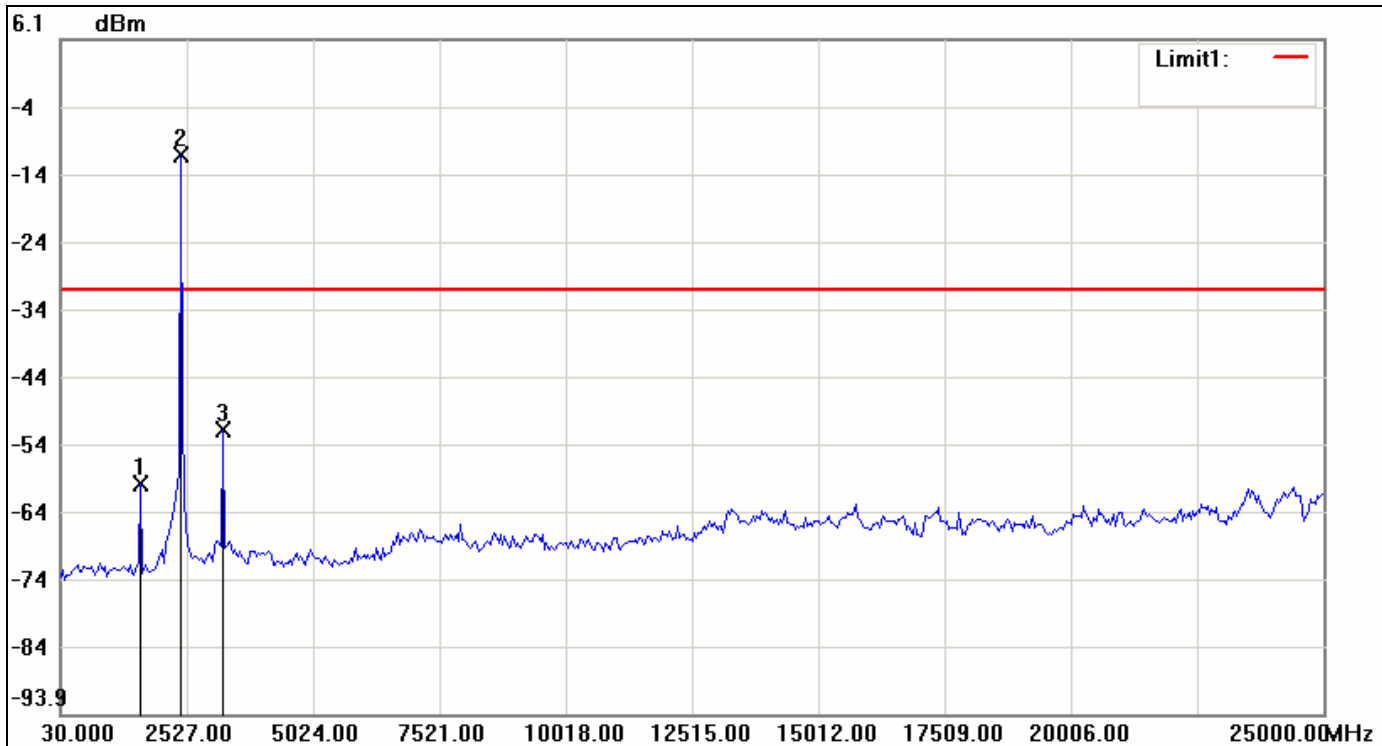

No.	Frequency(MHz)	Level(dBm)	Limit(dBm)	Margin(dBm)
1	1611.4333	-59.80	-30.97	-28.83
2	2402.1500	-10.97	-30.97	20.00
3	3234.4833	-51.76	-30.97	-20.79



CH Mid

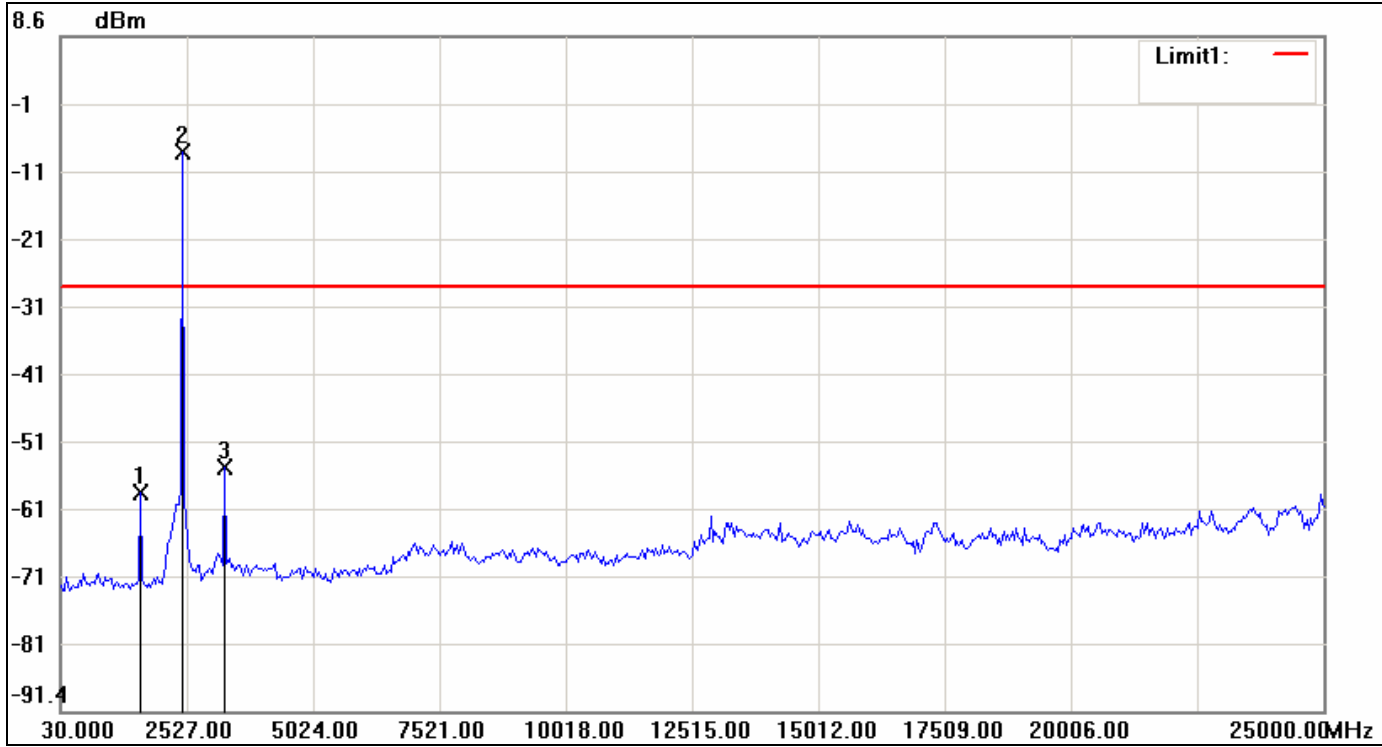

No.	Frequency(MHz)	Level(dBm)	Limit(dBm)	Margin(dBm)
1	1611.4333	-58.99	-28.53	-30.46
2	2443.7667	-8.53	-28.53	20.00
3	3276.1000	-55.36	-28.53	-26.83



CH High



No.	Frequency(MHz)	Level(dBm)	Limit(dBm)	Margin(dBm)
1	1653.0500	-59.28	-29.72	-29.56
2	2443.7667	-9.72	-29.72	20.00
3	3276.1000	-57.58	-29.72	-27.86



IEEE 802.11n HT 20 MHz mode / Chain 0

CH Low

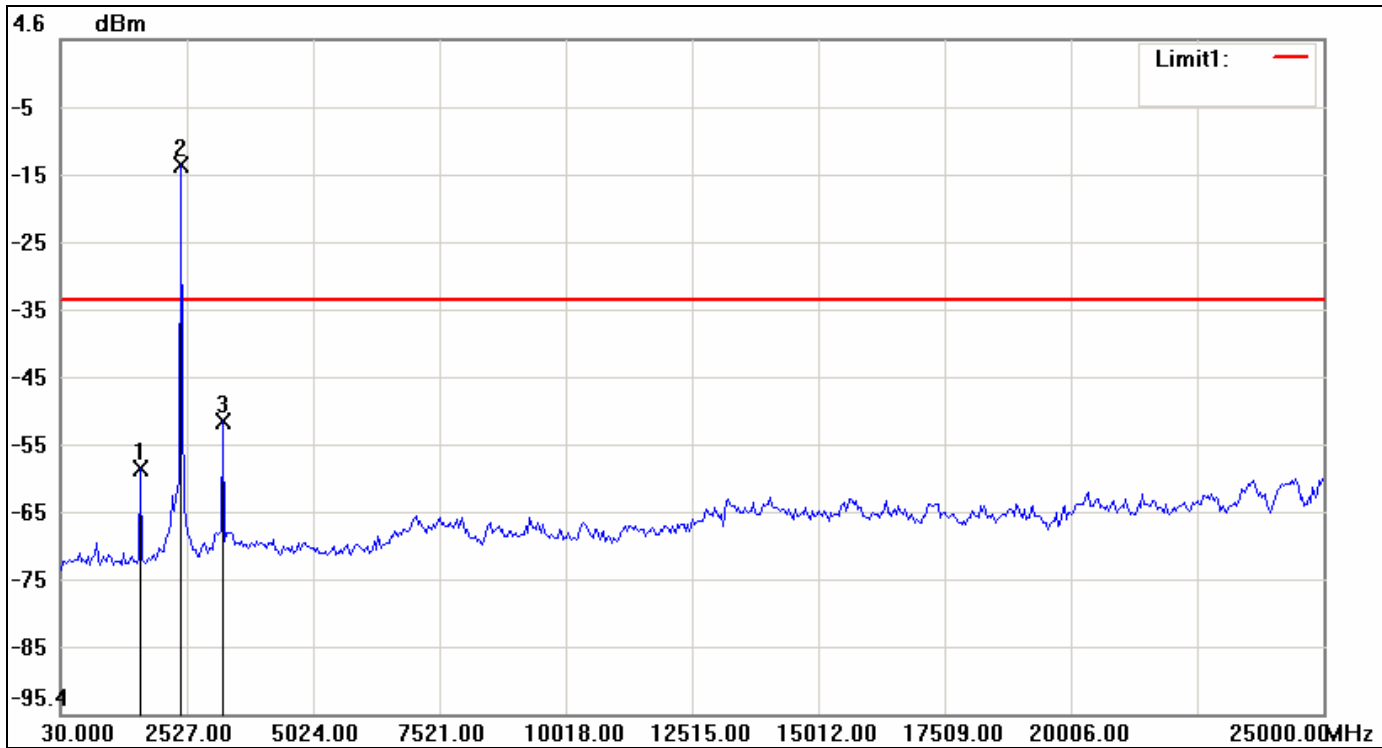

No.	Frequency(MHz)	Level(dBm)	Limit(dBm)	Margin(dBm)
1	1611.4333	-59.03	-34.05	-24.98
2	2402.1500	-14.05	-34.05	20.00
3	3234.4833	-51.98	-34.05	-17.93



CH Mid

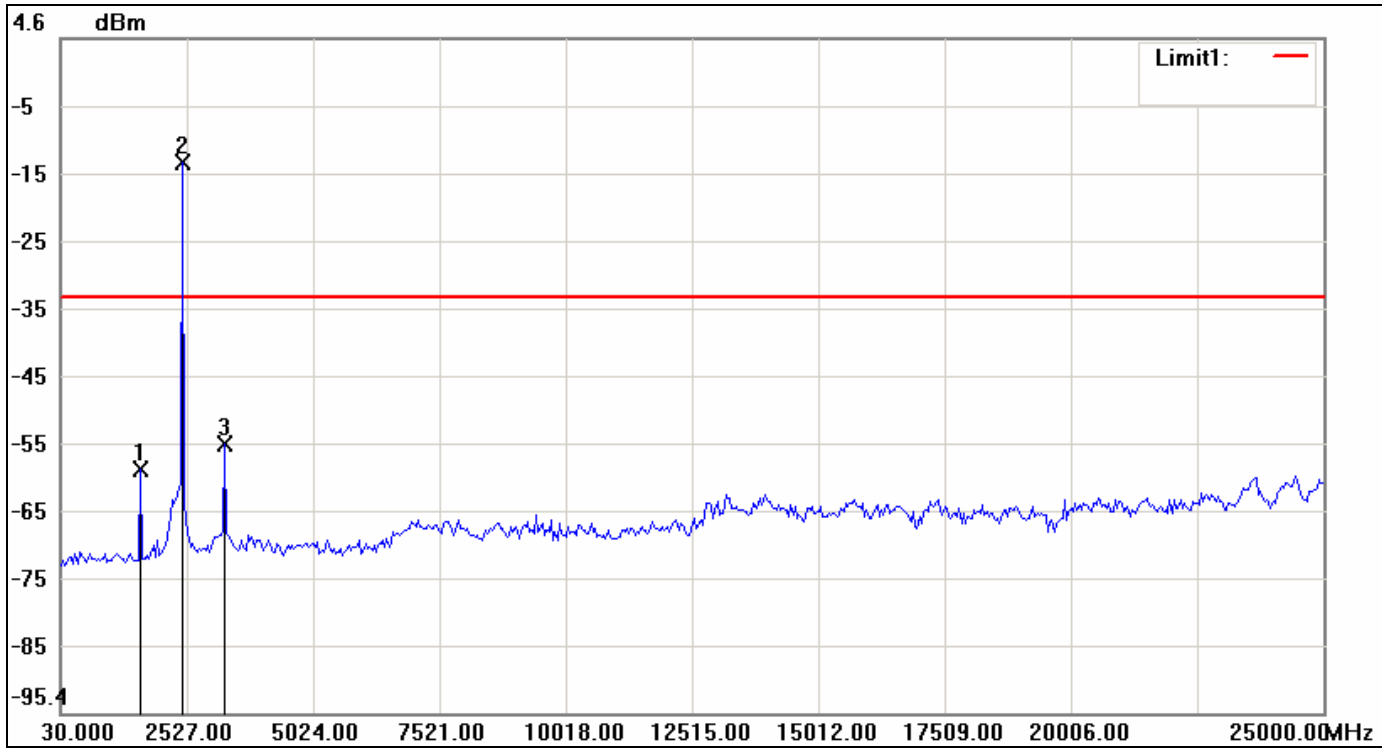

No.	Frequency(MHz)	Level(dBm)	Limit(dBm)	Margin(dBm)
1	1611.4333	-59.34	-33.88	-25.46
2	2443.7667	-13.88	-33.88	20.00
3	3276.1000	-55.45	-33.88	-21.57



CH High

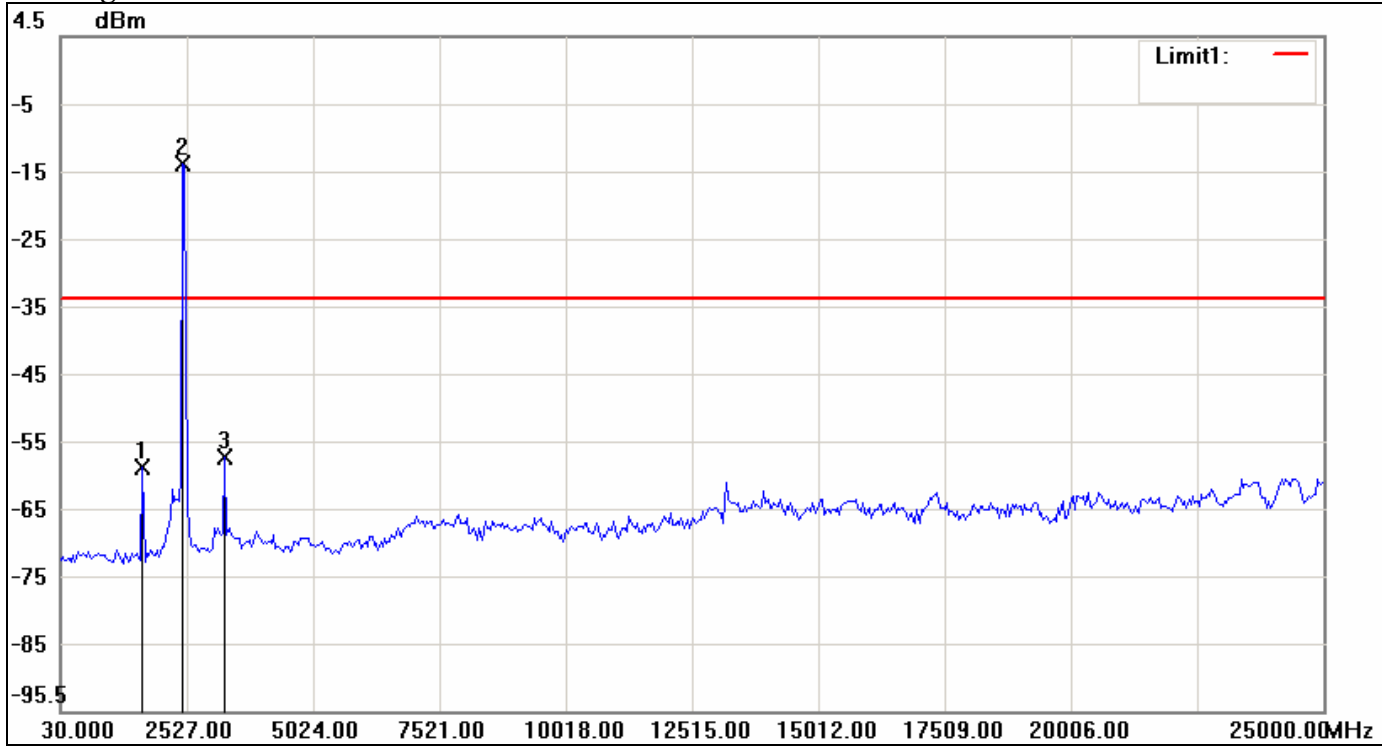

No.	Frequency(MHz)	Level(dBm)	Limit(dBm)	Margin(dBm)
1	1653.0500	-59.34	-34.34	-25.00
2	2443.7667	-14.34	-34.34	20.00
3	3276.1000	-57.90	-34.34	-23.56



IEEE 802.11n HT 20 MHz mode / Chain 1

CH Low

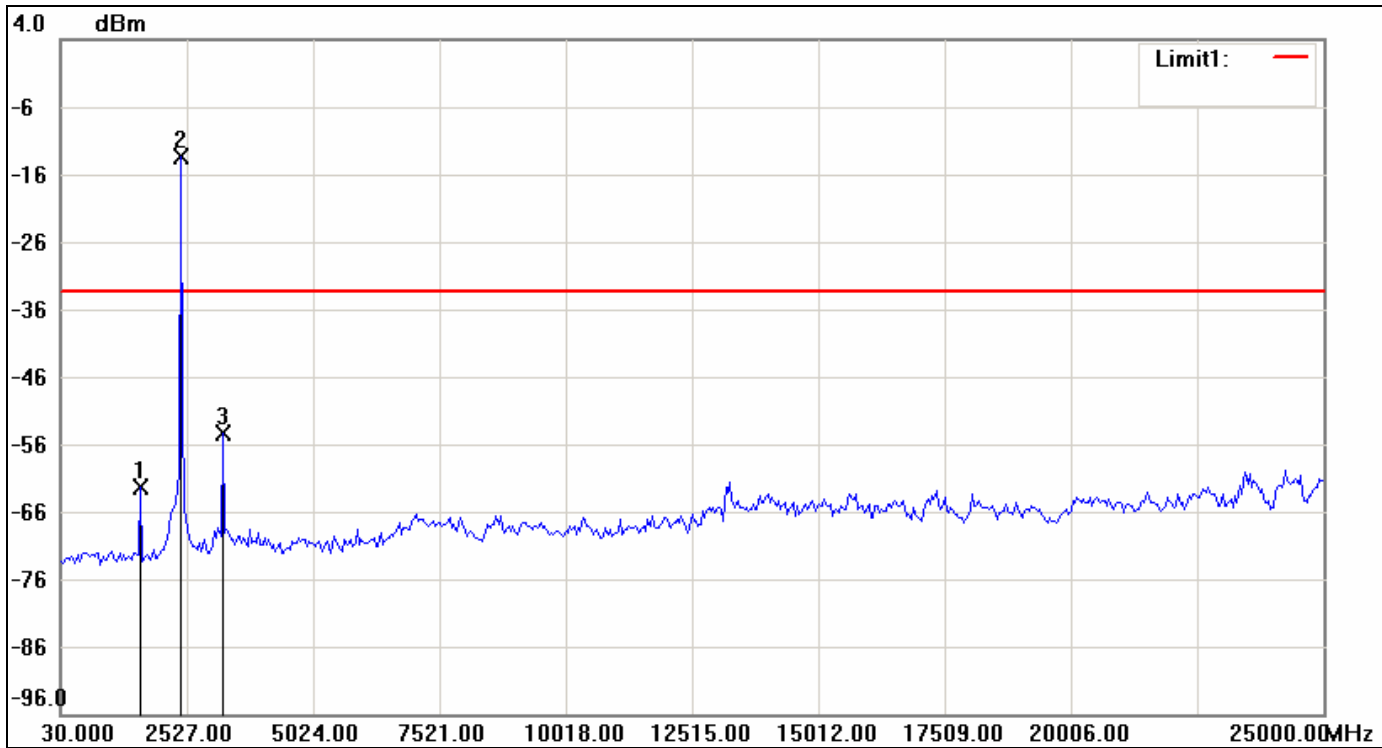

No.	Frequency(MHz)	Level(dBm)	Limit(dBm)	Margin(dBm)
1	1611.4333	-62.34	-33.41	-28.93
2	2402.1500	-13.41	-33.41	20.00
3	3234.4833	-54.49	-33.41	-21.08



CH Mid

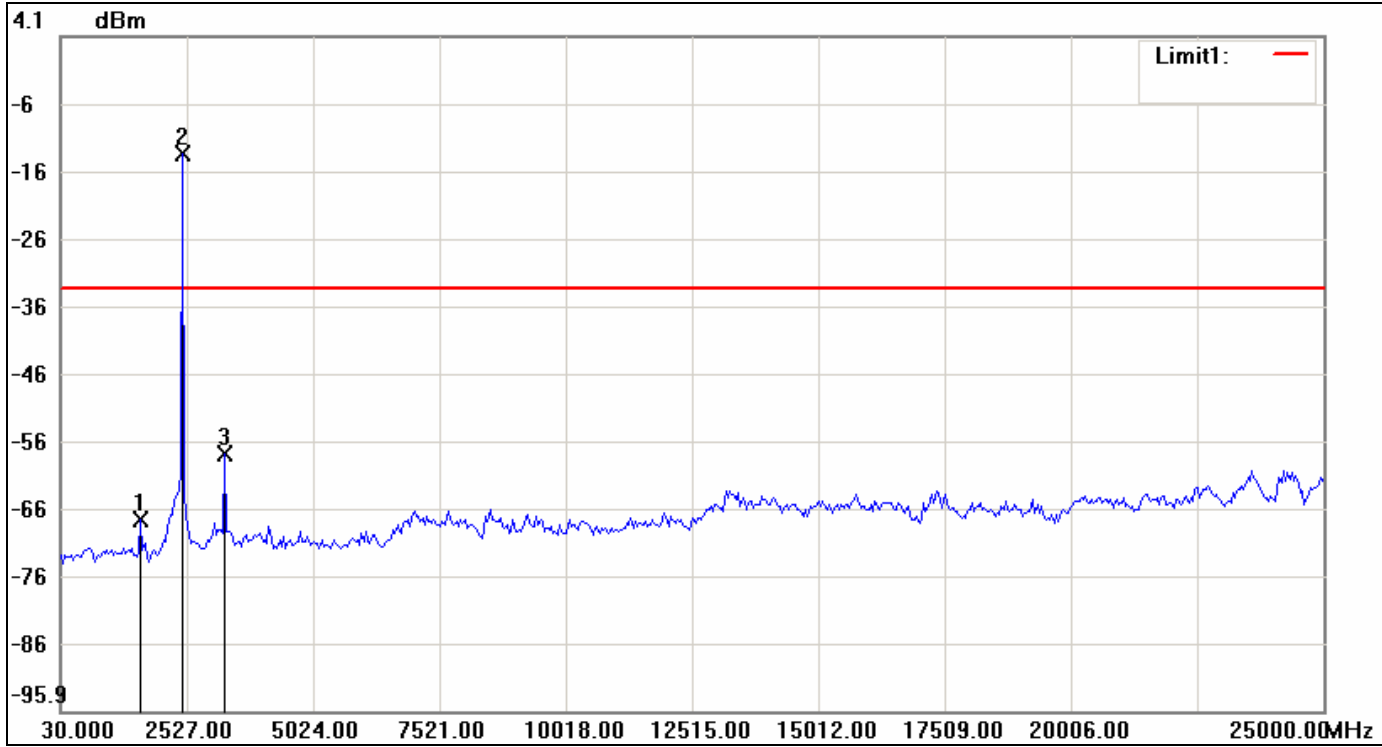

No.	Frequency(MHz)	Level(dBm)	Limit(dBm)	Margin(dBm)
1	1611.4333	-67.45	-33.20	-34.25
2	2443.7667	-13.20	-33.20	20.00
3	3276.1000	-57.67	-33.20	-24.47



CH High

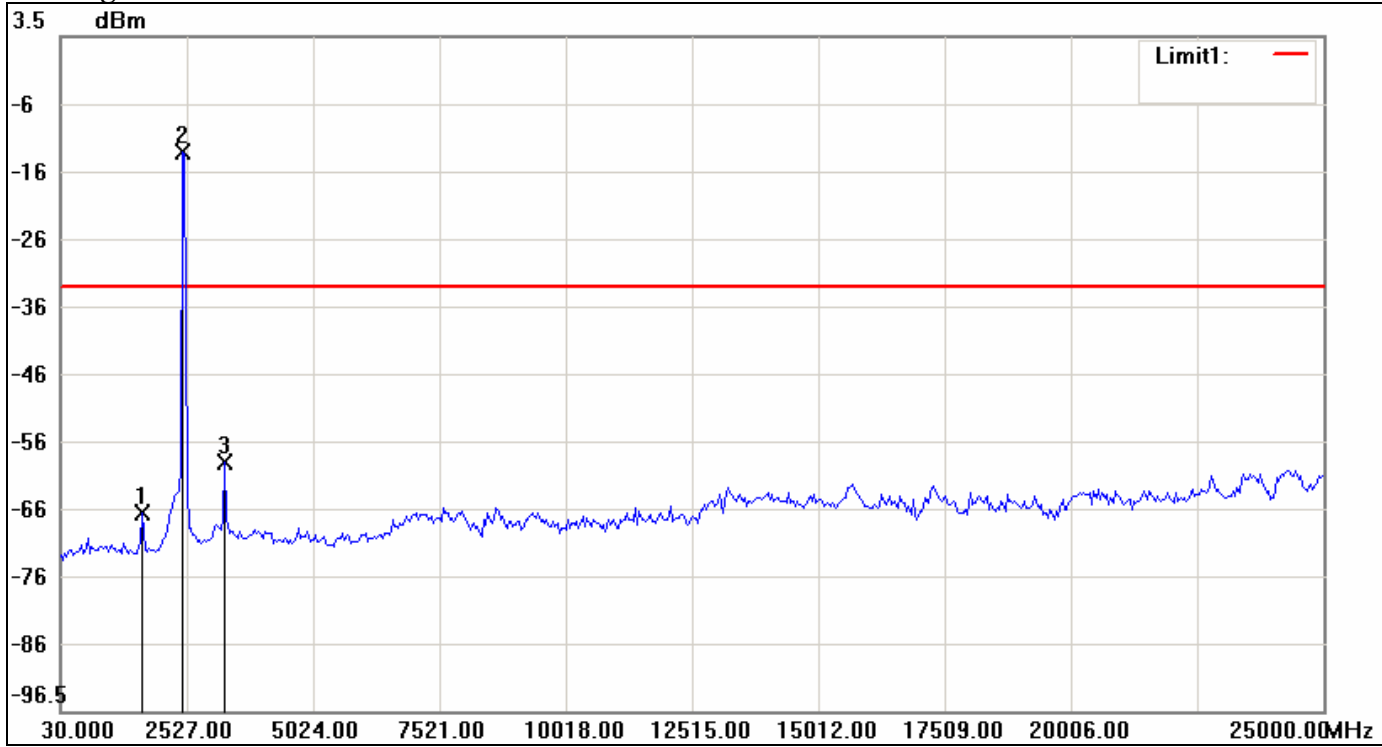

No.	Frequency(MHz)	Level(dBm)	Limit(dBm)	Margin(dBm)
1	1653.0500	-67.10	-33.52	-33.58
2	2443.7667	-13.52	-33.52	20.00
3	3276.1000	-59.72	-33.52	-26.20



IEEE 802.11n HT 20 MHz mode / Chain 2

CH Low

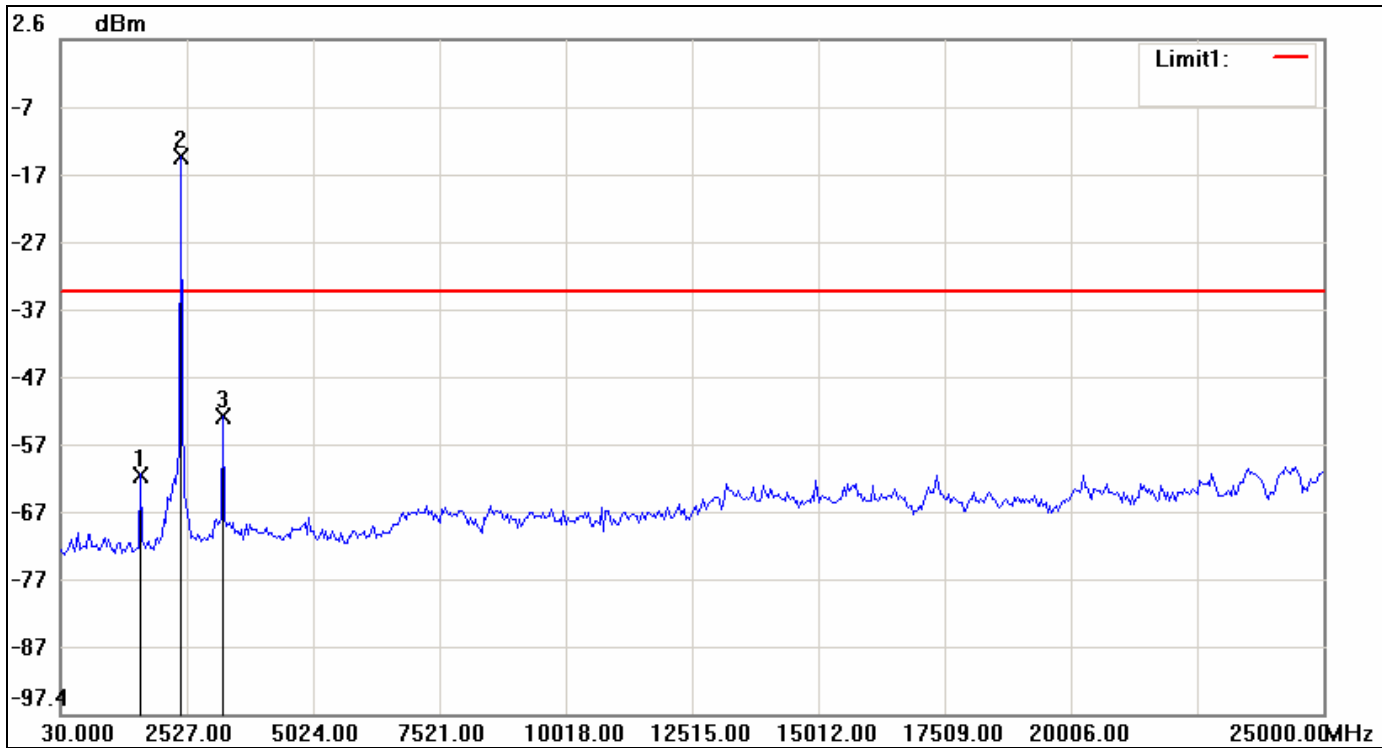

No.	Frequency(MHz)	Level(dBm)	Limit(dBm)	Margin(dBm)
1	1611.4333	-61.94	-34.80	-27.14
2	2402.1500	-14.80	-34.80	20.00
3	3234.4833	-53.29	-34.80	-18.49



CH Mid

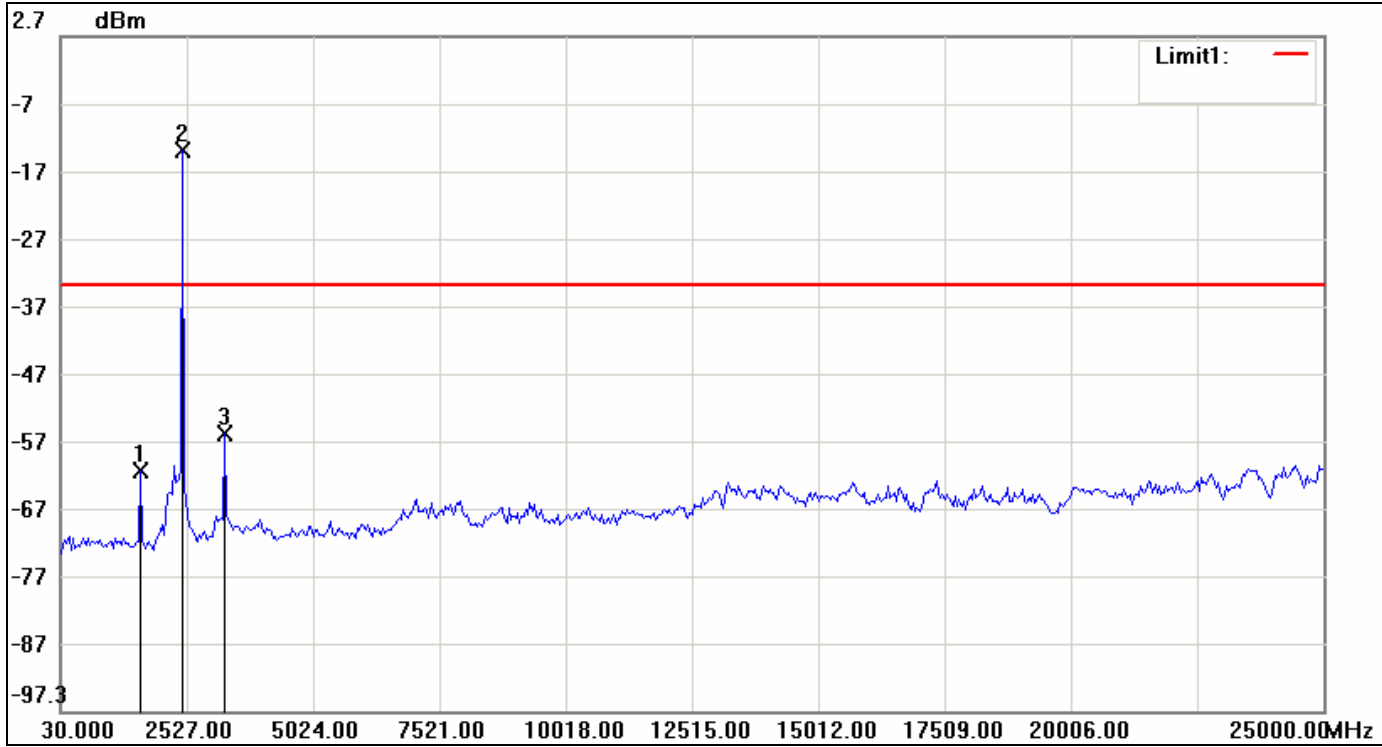

No.	Frequency(MHz)	Level(dBm)	Limit(dBm)	Margin(dBm)
1	1611.4333	-61.62	-34.28	-27.34
2	2443.7667	-14.28	-34.28	20.00
3	3276.1000	-56.31	-34.28	-22.03



CH High

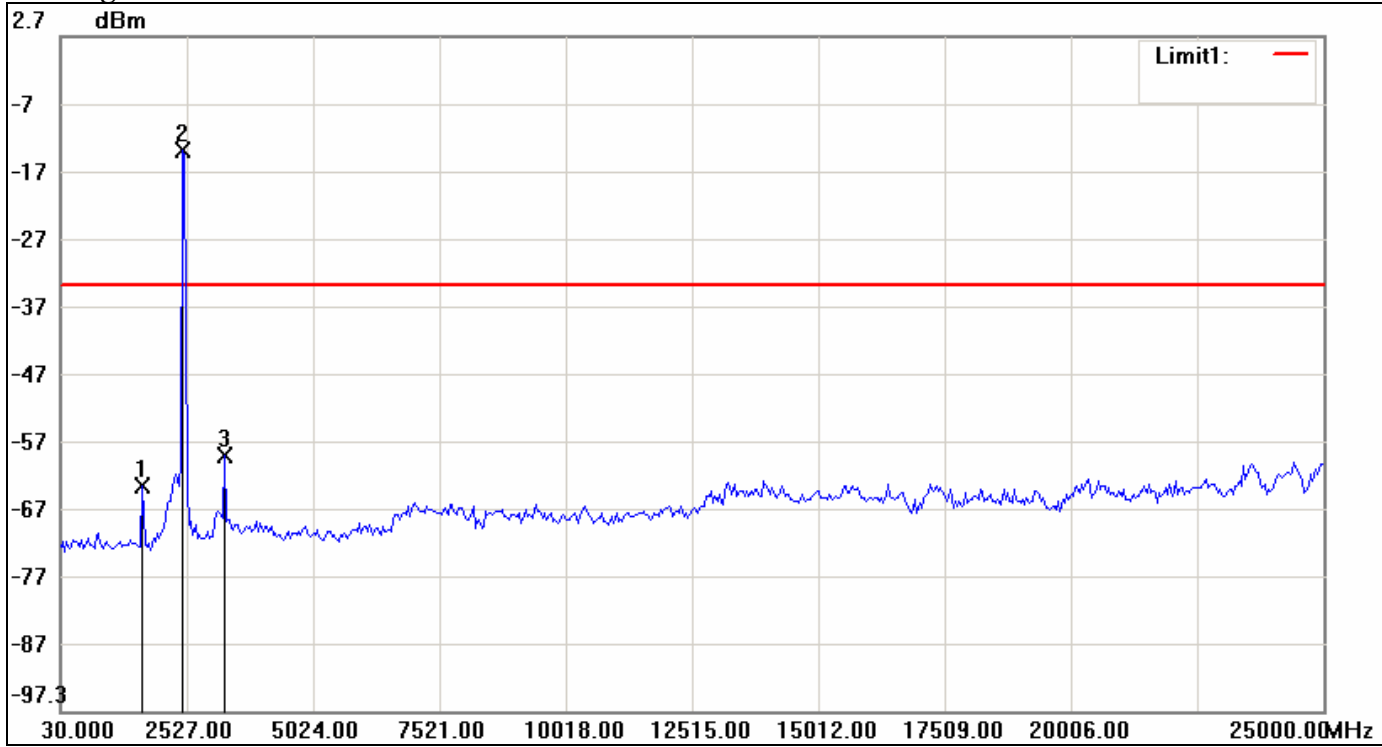

No.	Frequency(MHz)	Level(dBm)	Limit(dBm)	Margin(dBm)
1	1653.0500	-63.96	-34.06	-29.90
2	2443.7667	-14.06	-34.06	20.00
3	3276.1000	-59.30	-34.06	-25.24



IEEE 802.11n HT 40 MHz mode / Chain 0

CH Low

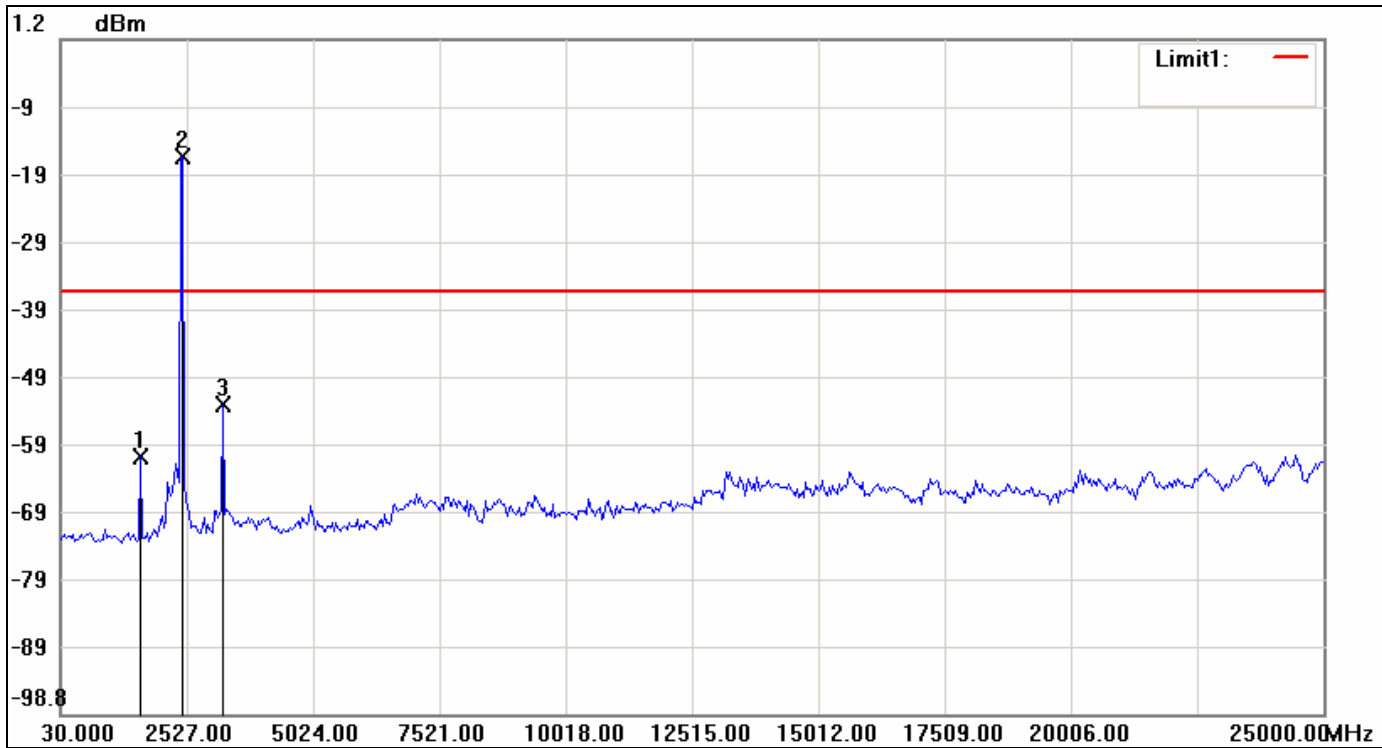

No.	Frequency(MHz)	Level(dBm)	Limit(dBm)	Margin(dBm)
1	1611.4333	-60.55	-36.16	-24.39
2	2443.7667	-16.16	-36.16	20.00
3	3234.4833	-52.91	-36.16	-16.75



CH Mid

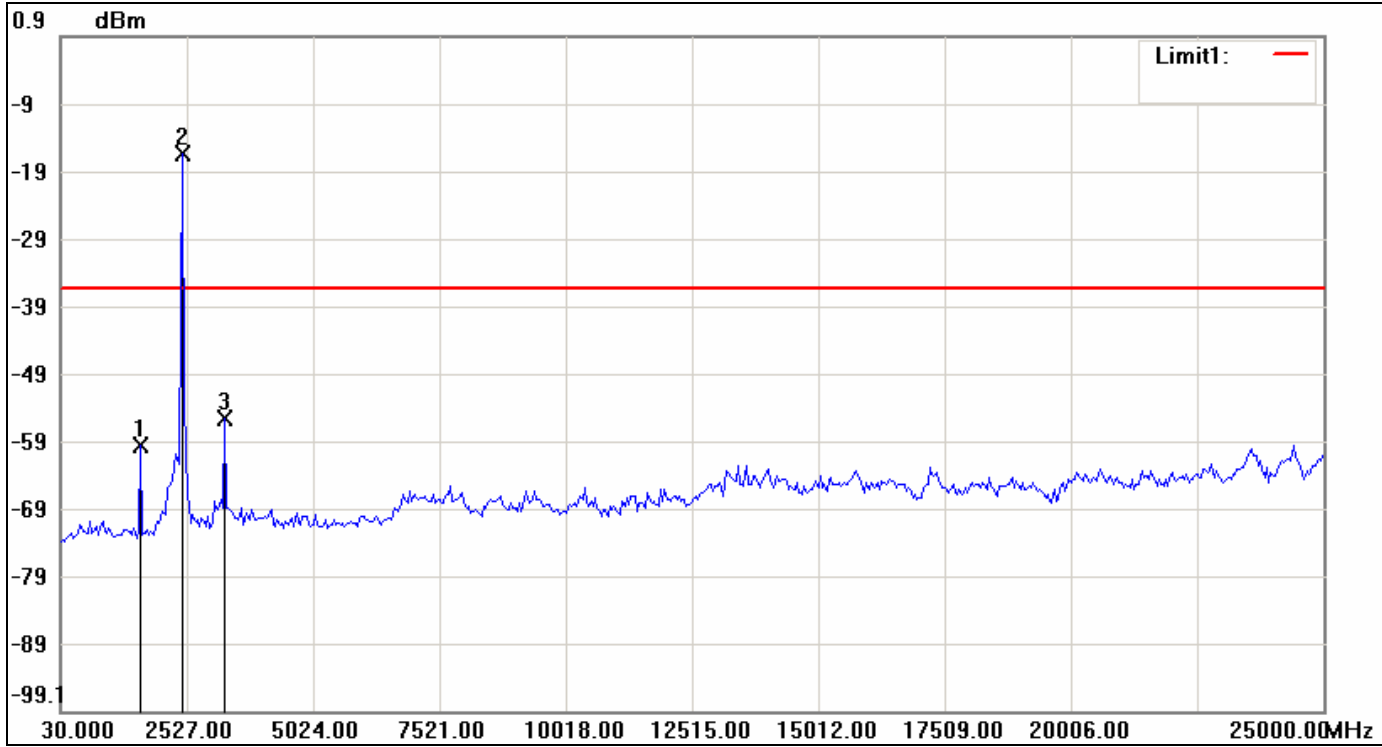

No.	Frequency(MHz)	Level(dBm)	Limit(dBm)	Margin(dBm)
1	1611.4333	-59.62	-36.47	-23.15
2	2443.7667	-16.47	-36.47	20.00
3	3276.1000	-55.65	-36.47	-19.18



CH High

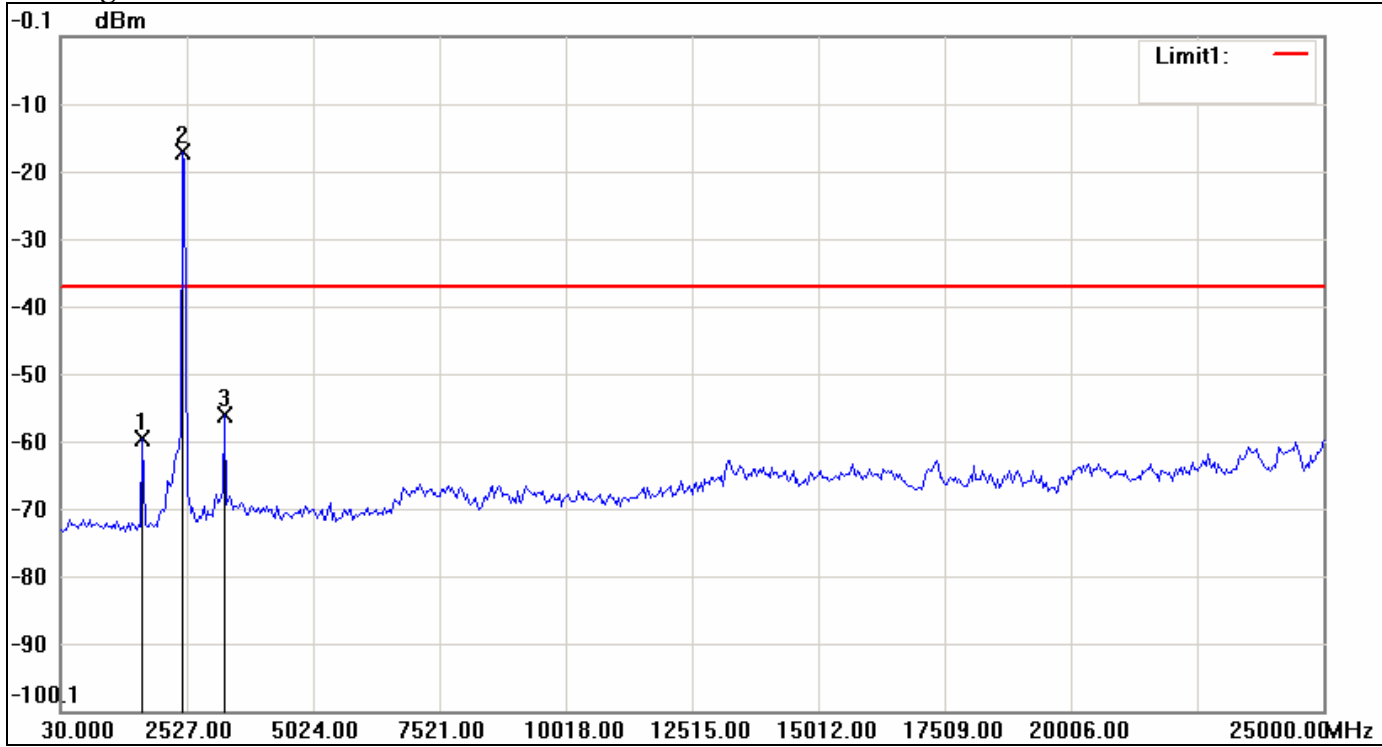

No.	Frequency(MHz)	Level(dBm)	Limit(dBm)	Margin(dBm)
1	1653.0500	-59.77	-37.20	-22.57
2	2443.7667	-17.20	-37.20	20.00
3	3276.1000	-56.34	-37.20	-19.14



IEEE 802.11n HT 40 MHz mode / Chain 1

CH Low

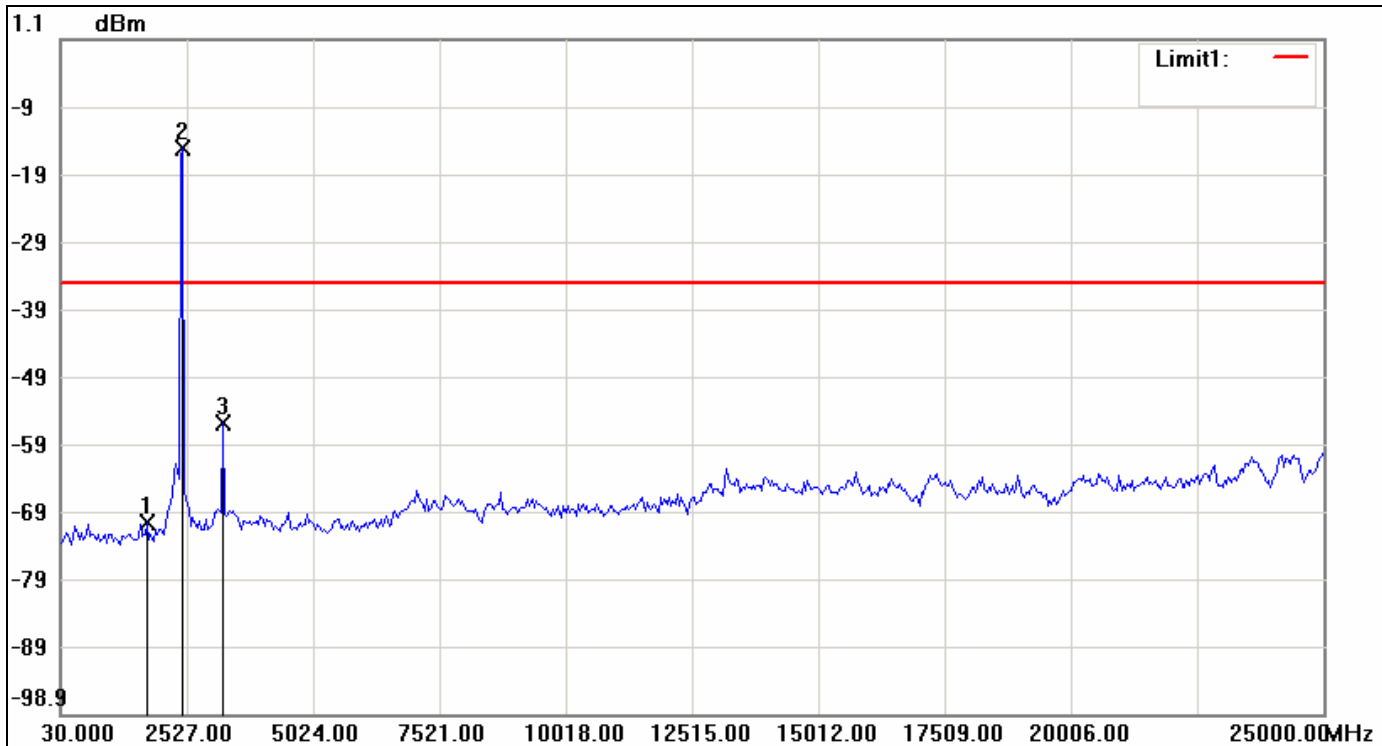

No.	Frequency(MHz)	Level(dBm)	Limit(dBm)	Margin(dBm)
1	1736.2833	-70.55	-35.01	-35.54
2	2443.7667	-15.01	-35.01	20.00
3	3234.4833	-55.74	-35.01	-20.73



CH Mid

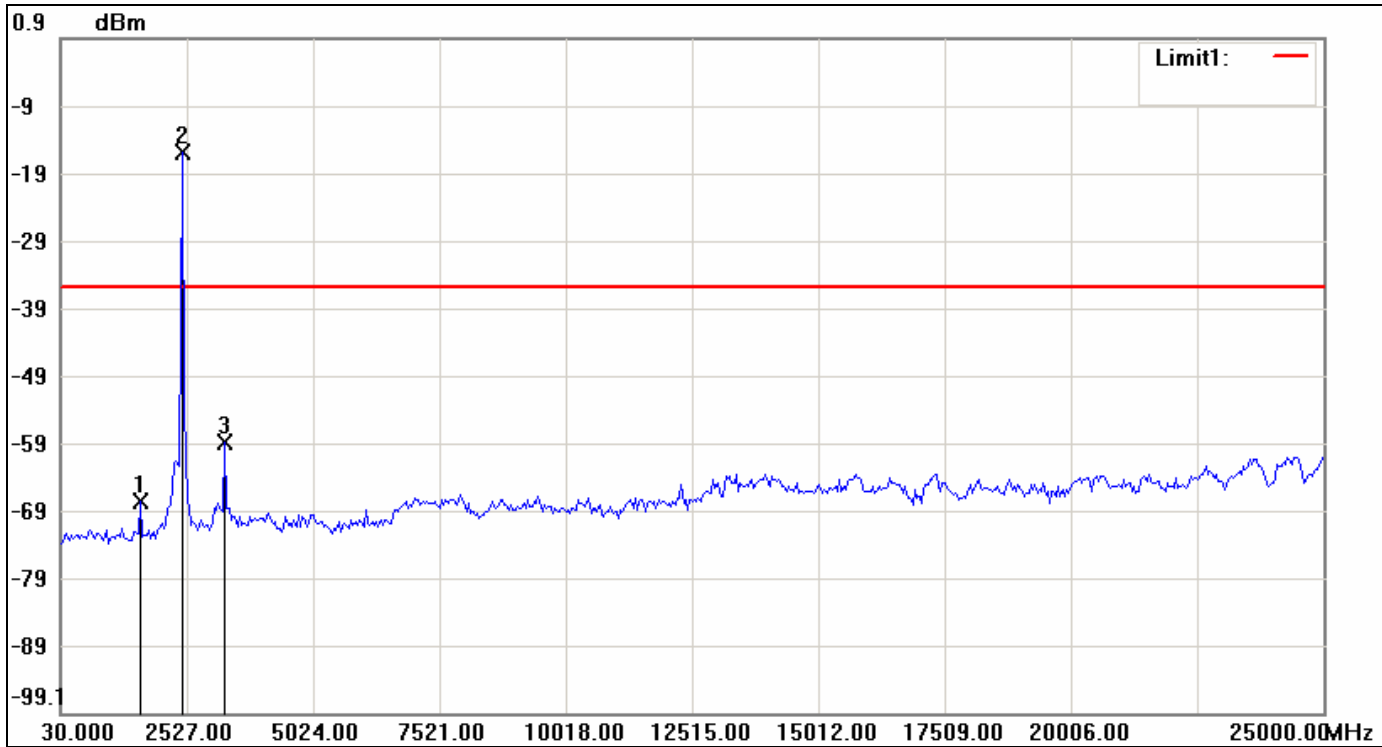

No.	Frequency(MHz)	Level(dBm)	Limit(dBm)	Margin(dBm)
1	1611.4333	-67.65	-36.05	-31.60
2	2443.7667	-16.05	-36.05	20.00
3	3276.1000	-58.90	-36.05	-22.85



CH High

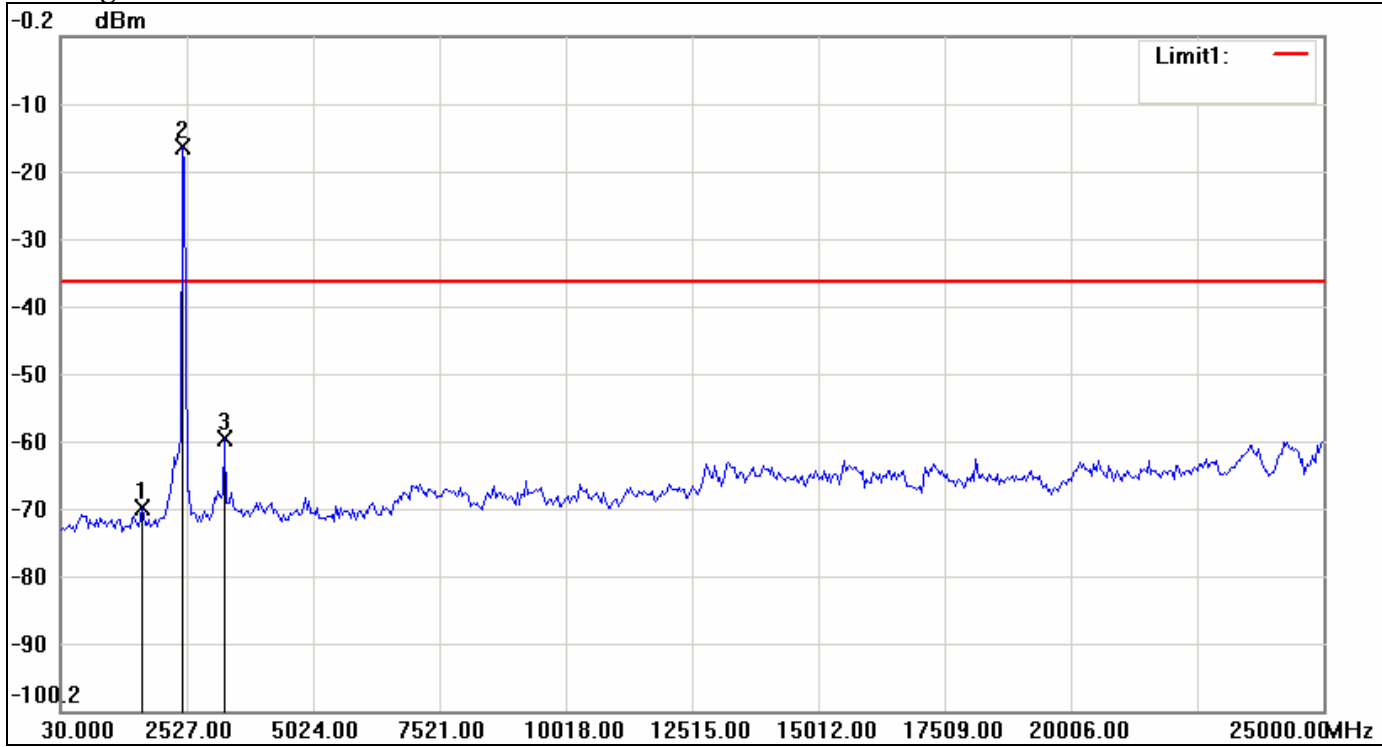

No.	Frequency(MHz)	Level(dBm)	Limit(dBm)	Margin(dBm)
1	1653.0500	-70.14	-36.49	-33.65
2	2443.7667	-16.49	-36.49	20.00
3	3276.1000	-59.73	-36.49	-23.24



IEEE 802.11n HT 40 MHz mode / Chain 2

CH Low

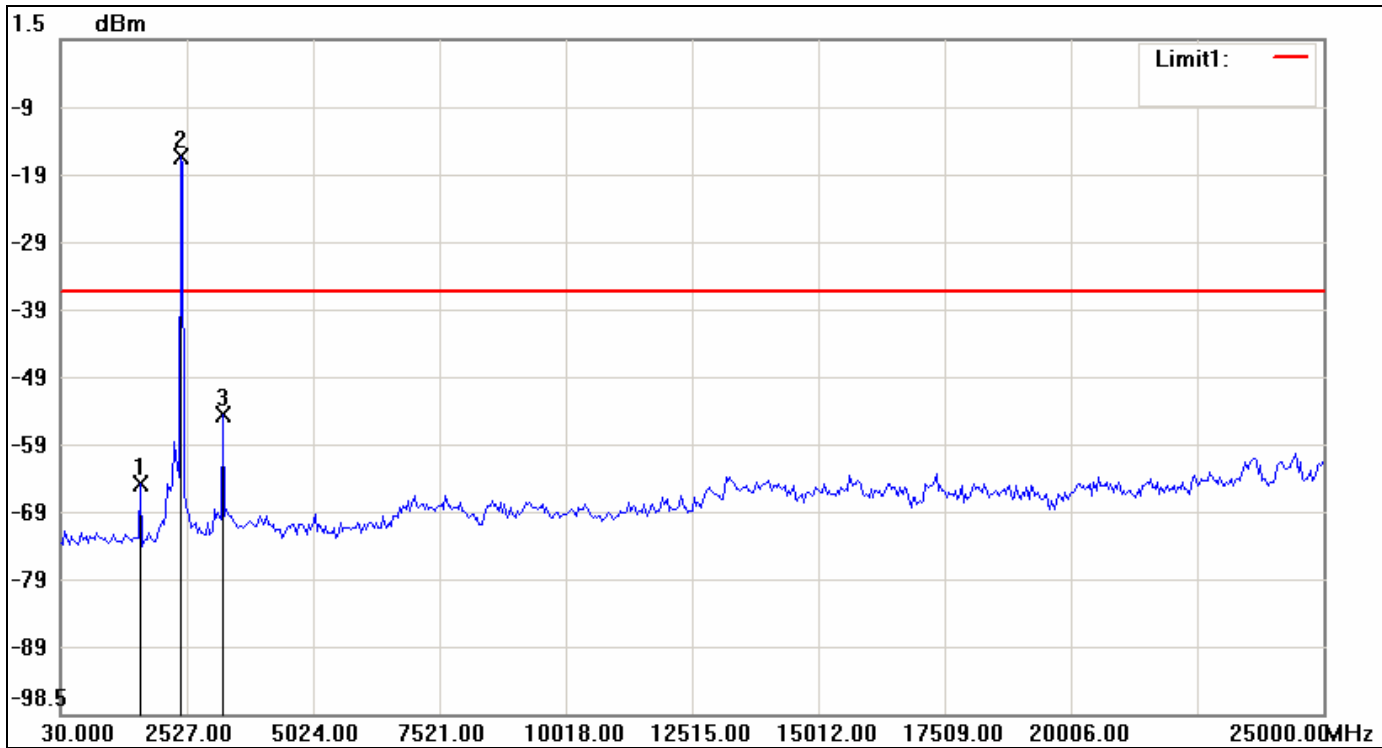

No.	Frequency(MHz)	Level(dBm)	Limit(dBm)	Margin(dBm)
1	1611.4333	-64.48	-35.94	-28.54
2	2402.1500	-15.94	-35.94	20.00
3	3234.4833	-54.22	-35.94	-18.28



CH Mid

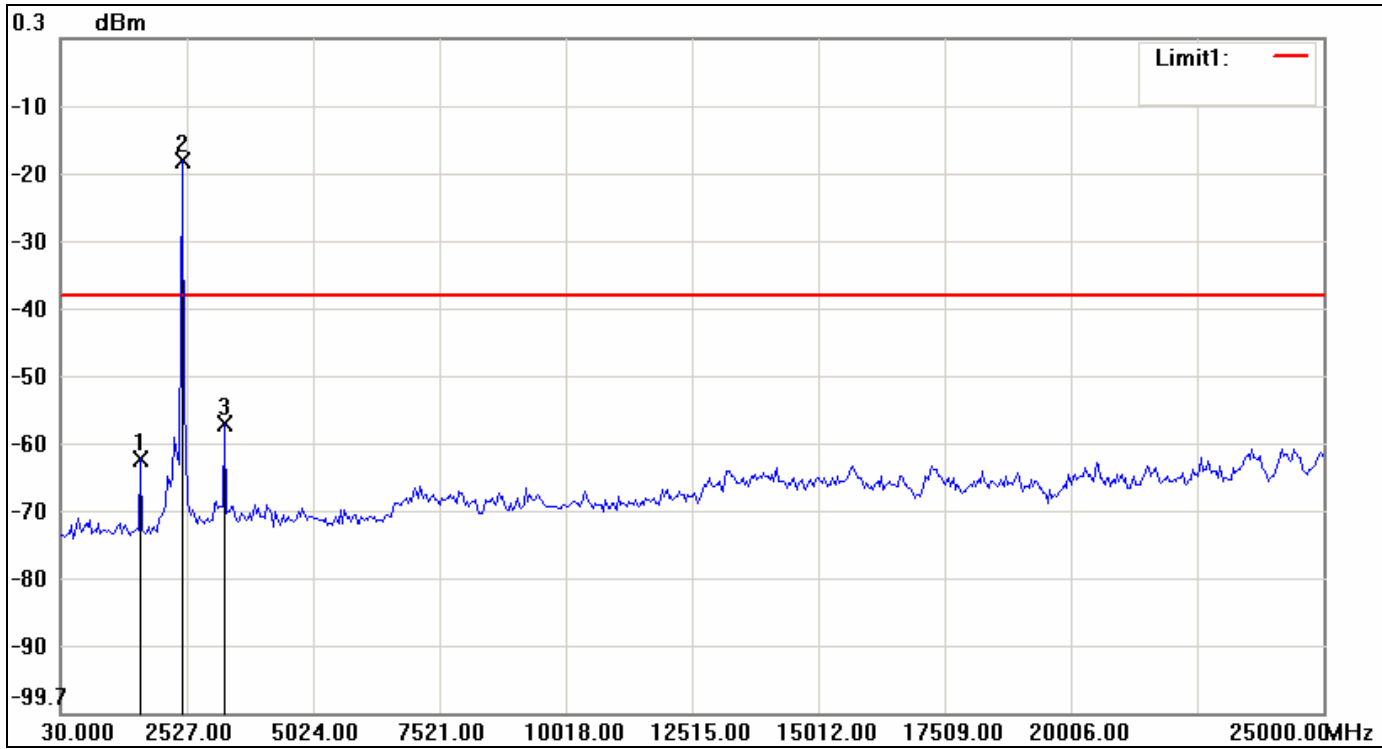

No.	Frequency(MHz)	Level(dBm)	Limit(dBm)	Margin(dBm)
1	1611.4333	-61.96	-37.86	-24.10
2	2443.7667	-17.86	-37.86	20.00
3	3276.1000	-56.84	-37.86	-18.98



CH High

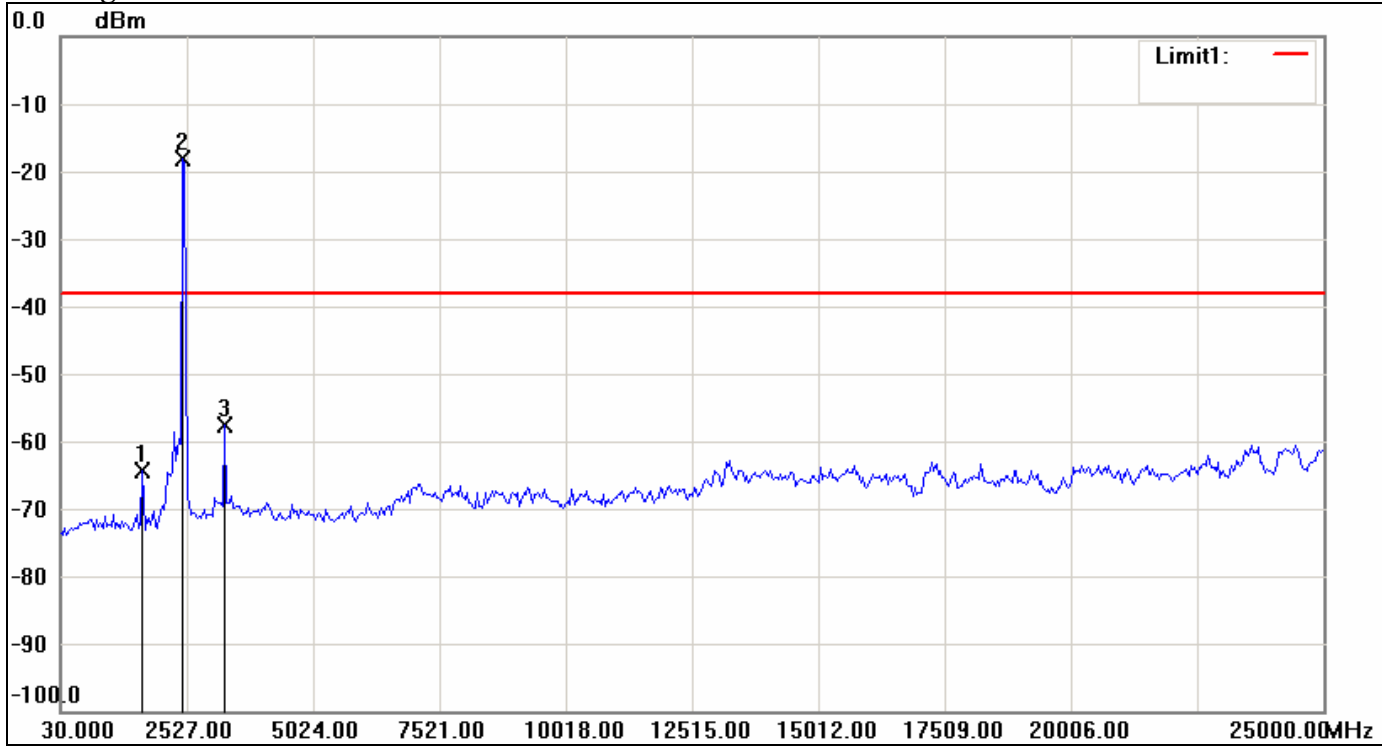

No.	Frequency(MHz)	Level(dBm)	Limit(dBm)	Margin(dBm)
1	1653.0500	-64.37	-38.21	-26.16
2	2443.7667	-18.21	-38.21	20.00
3	3276.1000	-57.60	-38.21	-19.39



IEEE 802.11n HT 20 MHz mode with combiner

CH Low

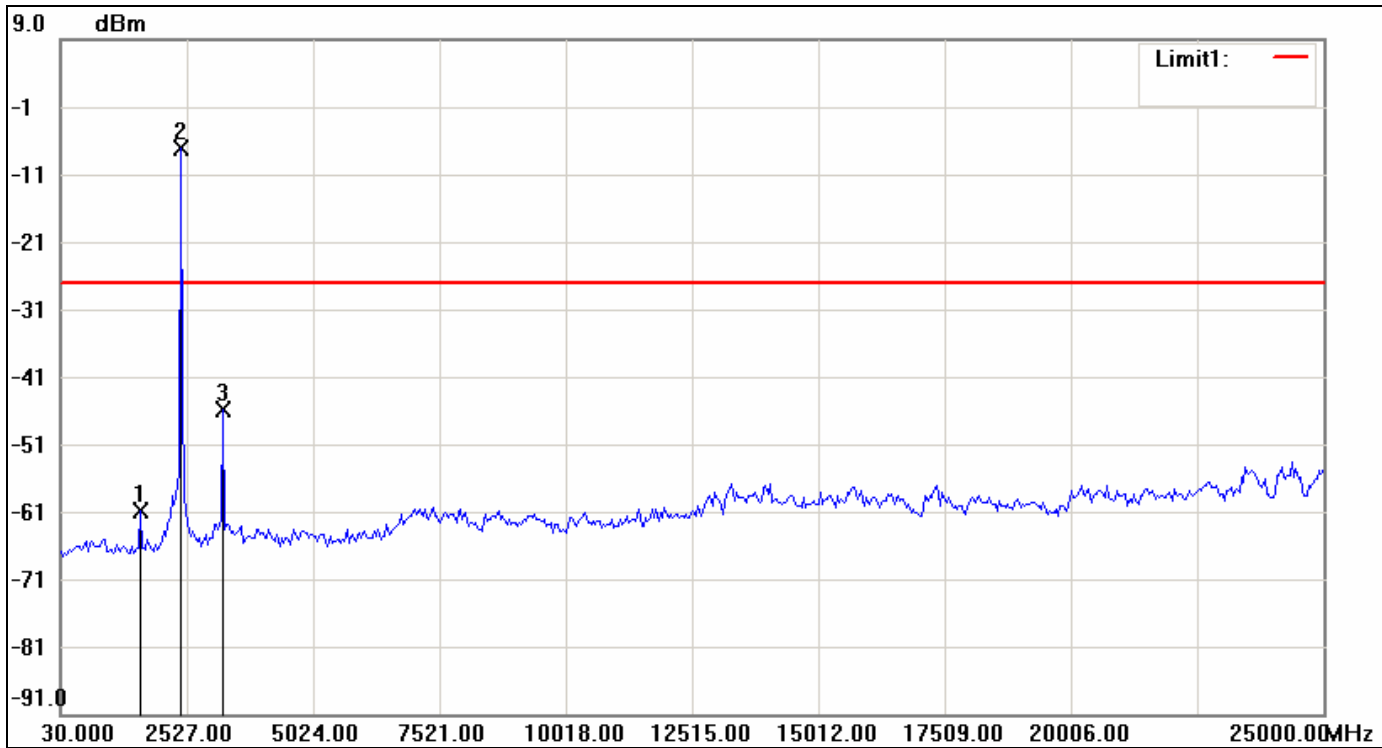

No.	Frequency(MHz)	Level(dBm)	Limit(dBm)	Margin(dBm)
1	1611.4333	-60.82	-27.21	-33.61
2	2402.1500	-7.21	-27.21	20.00
3	3234.4833	-45.80	-27.21	-18.59



CH Mid

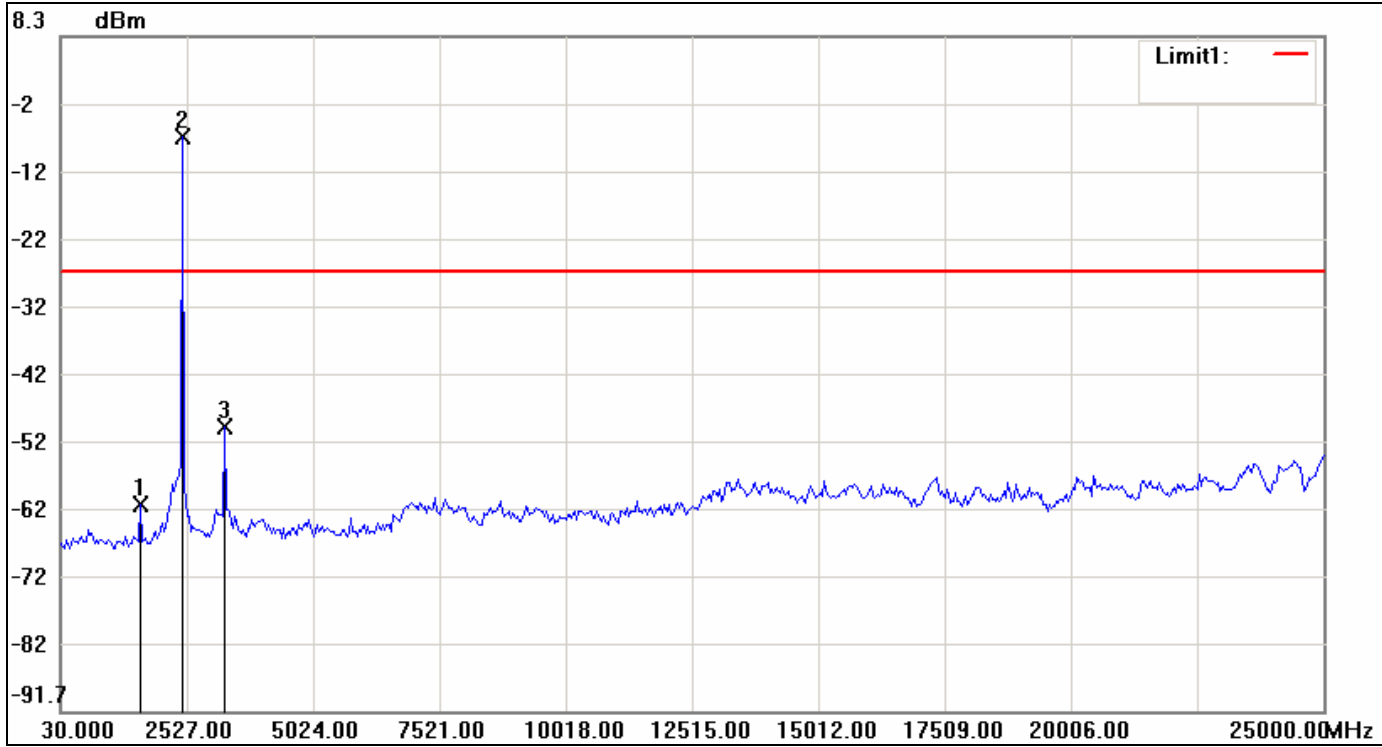

No.	Frequency(MHz)	Level(dBm)	Limit(dBm)	Margin(dBm)
1	1611.4333	-61.13	-26.60	-34.53
2	2443.7667	-6.60	-26.60	20.00
3	3276.1000	-49.61	-26.60	-23.01



CH High

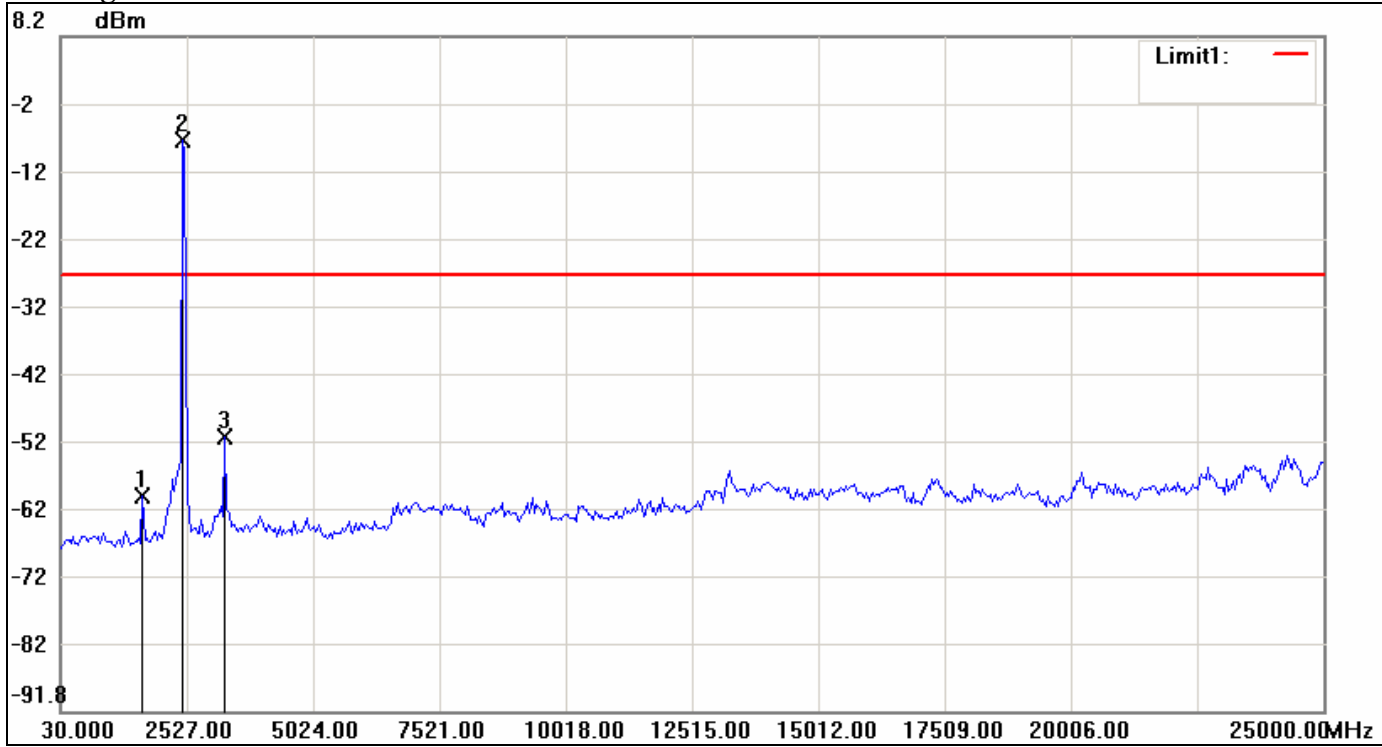

No.	Frequency(MHz)	Level(dBm)	Limit(dBm)	Margin(dBm)
1	1653.0500	-59.92	-27.12	-32.80
2	2443.7667	-7.12	-27.12	20.00
3	3276.1000	-51.18	-27.12	-24.06



IEEE 802.11n HT 40 MHz mode with combiner

CH Low

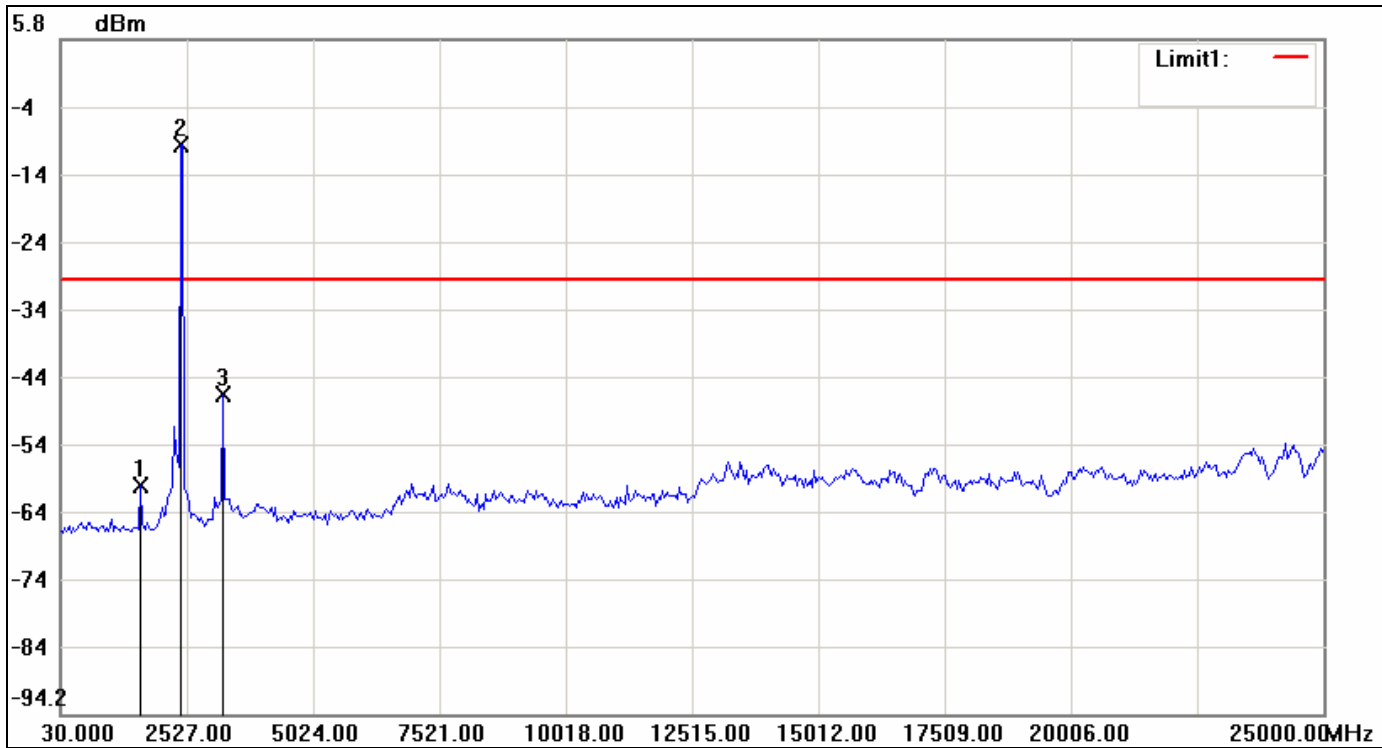

No.	Frequency(MHz)	Level(dBm)	Limit(dBm)	Margin(dBm)
1	1611.4333	-60.35	-29.78	-30.57
2	2402.1500	-9.78	-29.78	20.00
3	3234.4833	-46.77	-29.78	-16.99



CH Mid

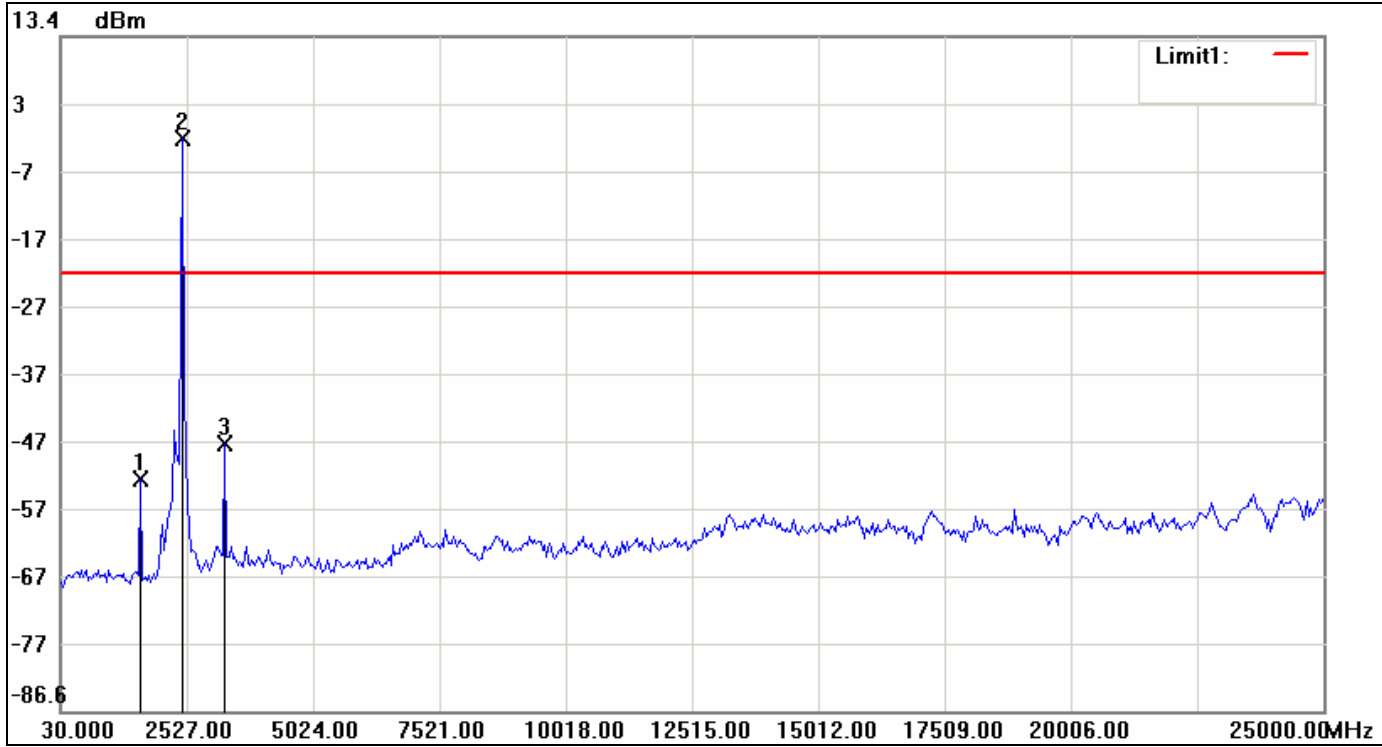

No.	Frequency(MHz)	Level(dBm)	Limit(dBm)	Margin(dBm)
1	1611.4333	-52.34	-21.75	-30.59
2	2443.7667	-1.75	-21.75	20.00
3	3276.1000	-47.05	-21.75	-25.30



CH High

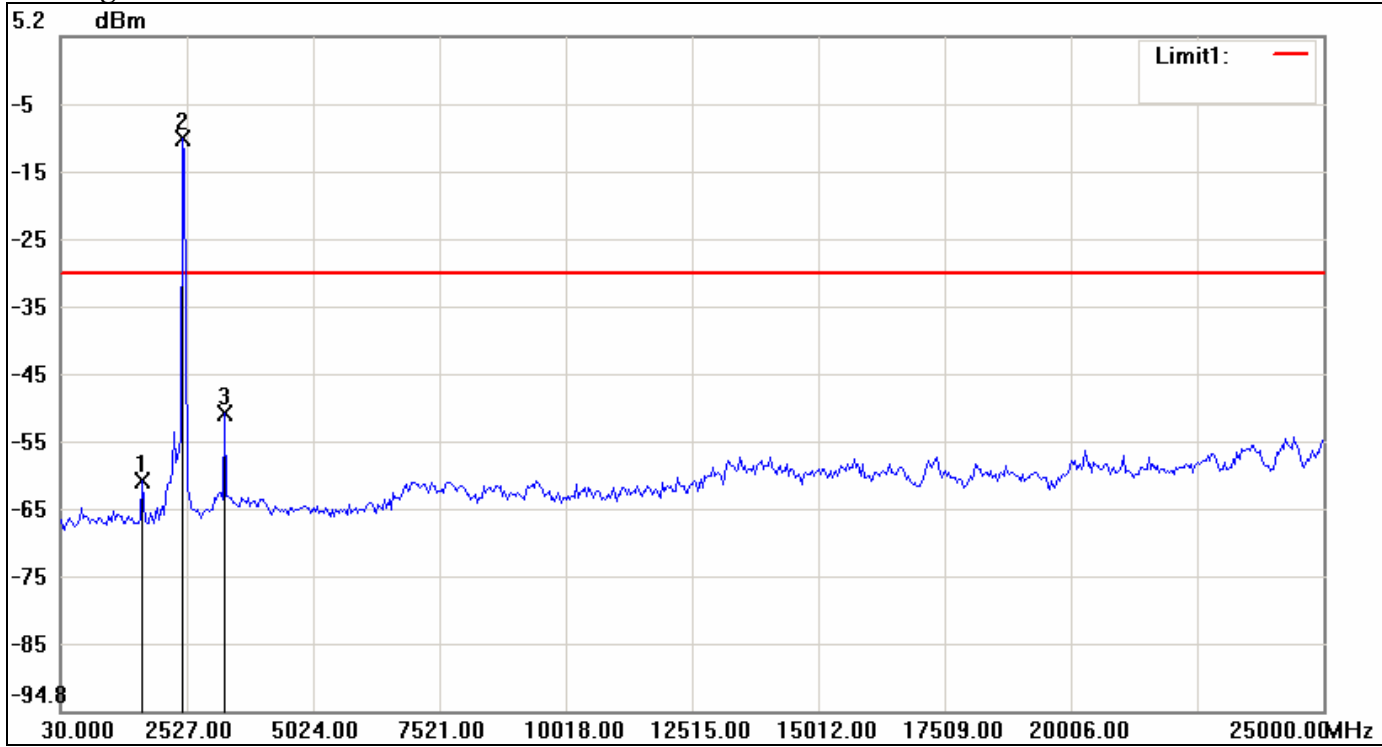

No.	Frequency(MHz)	Level(dBm)	Limit(dBm)	Margin(dBm)
1	1653.0500	-60.79	-29.83	-30.96
2	2443.7667	-9.83	-29.83	20.00
3	3276.1000	-50.76	-29.83	-20.93



7.7 RADIATED EMISSIONS

LIMIT

1. According to §15.209(a), except as provided elsewhere in this Subpart, the emissions from an intentional radiator shall not exceed the field strength levels specified in the following table:

Frequency (MHz)	Field Strength ($\mu\text{V}/\text{m}$)	Measurement Distance (m)
30-88	100*	3
88-216	150*	3
216-960	200*	3
Above 960	500	3

Remark: Except as provided in paragraph (g), fundamental emissions from intentional radiators operating under this Section shall not be located in the frequency bands 54-72 MHz, 76-88 MHz, 174-216 MHz or 470-806 MHz. However, operation within these frequency bands is permitted under other sections of this Part, e.g., Sections 15.231 and 15.241.

2. In the emission table above, the tighter limit applies at the band edges.

Frequency (MHz)	Field Strength ($\mu\text{V}/\text{m}$ at 3-meter)	Field Strength (dB $\mu\text{V}/\text{m}$ at 3-meter)
30-88	100	40
88-216	150	43.5
216-960	200	46
Above 960	500	54



Test Configuration

9kHz ~ 30MHz

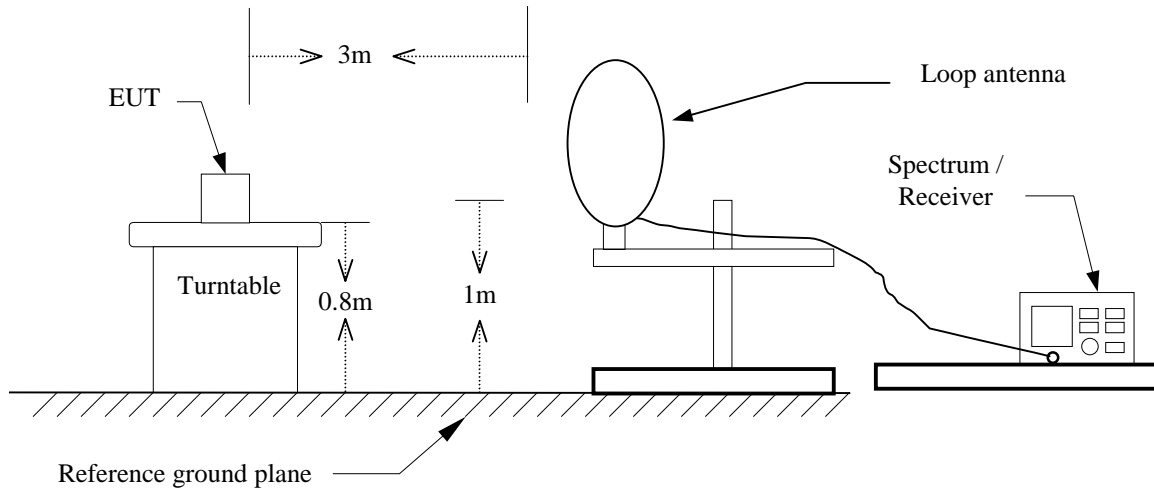

30MHz ~ 1GHz

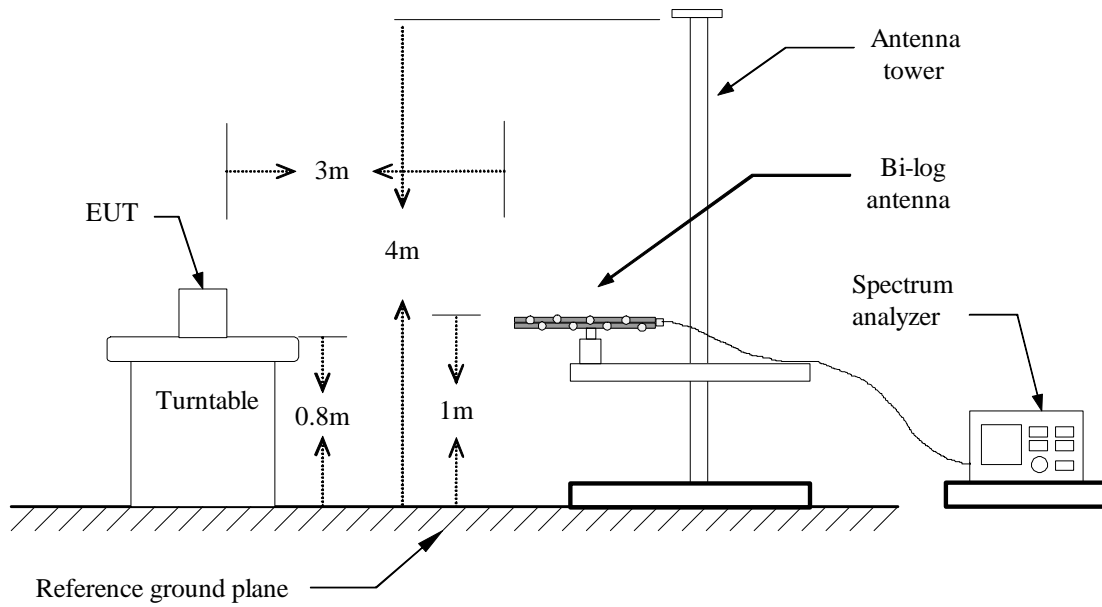



Above 1 GHz

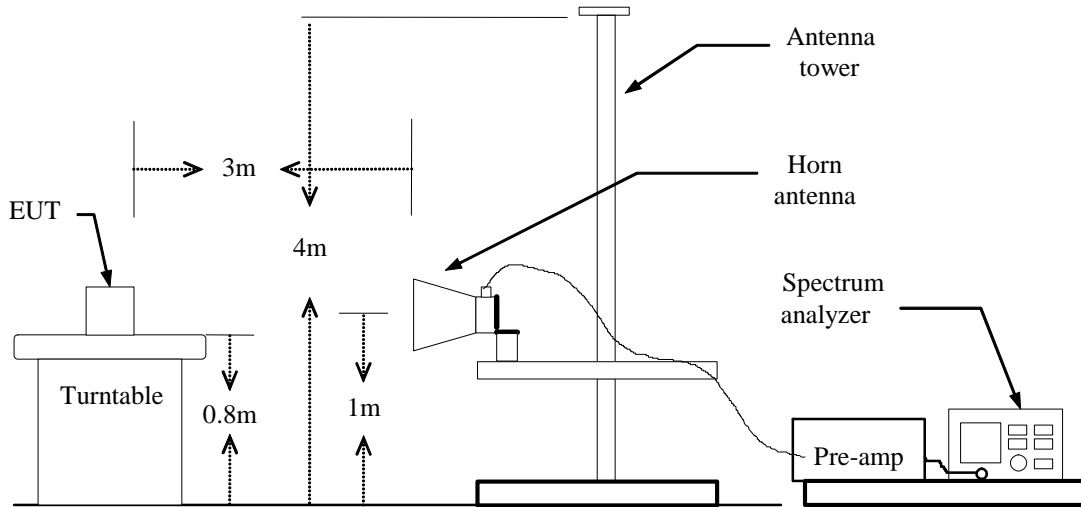



TEST PROCEDURE

1. The EUT is placed on a turntable, which is 0.8m above ground plane.
2. The turntable shall be rotated for 360 degrees to determine the position of maximum emission level.
3. EUT is set 3m away from the receiving antenna, which is varied from 1m to 4m to find out the highest emissions.
4. Maximum procedure was performed on the six highest emissions to ensure EUT compliance.
5. And also, each emission was to be maximized by changing the polarization of receiving antenna both horizontal and vertical.
6. Set the spectrum analyzer in the following setting as:
Below 1GHz:
RBW=100kHz / VBW=300kHz / Sweep=AUTO
Above 1GHz:
(a) PEAK: RBW=VBW=1MHz / Sweep=AUTO
(b) AVERAGE: RBW=1MHz / VBW=10Hz / Sweep=AUTO
7. Repeat above procedures until the measurements for all frequencies are complete.

**Below 1GHz****Operation Mode:** Normal Link**Test Date:** April 7, 2011**Temperature:** 24°C**Tested by:** Ali Shu**Humidity:** 50% RH**Polarity:** Ver. / Hor.

Frequency (MHz)	Reading (dBuV)	Correction Factor (dB/m)	Result (dBuV/m)	Limit (dBuV/m)	Margin (dB)	Remark	Ant. Pol. (H/V)
80.12	45.83	-15.14	30.68	40.00	-9.32	Peak	V
160.95	46.69	-10.60	36.08	43.50	-7.42	Peak	V
432.55	31.92	-6.29	25.63	46.00	-20.37	Peak	V
479.43	35.57	-5.44	30.13	46.00	-15.87	Peak	V
539.25	33.78	-4.62	29.17	46.00	-16.83	Peak	V
959.58	36.59	0.44	37.04	46.00	-8.96	Peak	V
80.12	46.94	-15.14	31.80	40.00	-8.20	Peak	H
180.35	45.63	-11.60	34.03	43.50	-9.47	Peak	H
299.98	42.73	-9.24	33.49	46.00	-12.51	Peak	H
479.43	36.43	-5.44	30.99	46.00	-15.01	Peak	H
660.50	32.79	-2.82	29.98	46.00	-16.02	Peak	H
959.58	41.62	0.44	42.07	46.00	-3.93	Peak	H

Remark:

1. No emission found between lowest internal used/generated frequency to 30MHz (9kHz~30MHz)
2. Radiated emissions measured in frequency range from 30 MHz to 1000MHz were made with an instrument using peak/quasi-peak detector mode.
3. Measurements above show only up to 6 maximum emissions noted, or would be lesser, with " N/A " remark, if no specific emissions from the EUT are recorded (ie: margin>20dB from the applicable limit) and considered that's already beyond the background noise floor.
4. $Margin (dB) = Result (dBuV/m) - Limit (dBuV/m)$.

**Above 1 GHz****Operation Mode:** TX / IEEE 802.11b / CH Low**Test Date:** April 6, 2011**Temperature:** 24°C**Tested by:** Ali Shu**Humidity:** 50 % RH**Polarity:** Ver. / Hor.

Frequency (MHz)	Reading (Peak) (dBuV)	Reading (Average) (dBuV)	Correction Factor (dB/m)	Result (Peak) (dBuV/m)	Result (Average) (dBuV/m)	Limit (Peak) (dBuV/m)	Limit (Average) (dBuV/m)	Margin (dB)	Remark	Ant. Pol. (H/V)
1993.33	58.28	49.67	-5.54	52.74	44.13	74.00	54.00	-9.87	AVG	V
2356.67	61.06	53.59	-4.46	56.60	49.13	74.00	54.00	-4.87	AVG	V
3216.67	53.04	---	-1.60	51.45	---	74.00	54.00	-2.55	Peak	V
4133.33	49.94	---	0.87	50.81	---	74.00	54.00	-3.19	Peak	V
4816.67	50.34	45.28	2.59	52.94	47.87	74.00	54.00	-6.13	AVG	V
7425.00	47.80	35.60	7.19	54.99	42.79	74.00	54.00	-11.21	AVG	V
1426.67	57.91	---	-10.63	47.28	---	74.00	54.00	-6.72	Peak	H
4875.00	49.04	40.71	2.71	51.75	43.42	74.00	54.00	-10.58	AVG	H
7233.33	46.91	42.15	7.26	54.17	49.41	74.00	54.00	-4.59	AVG	H
N/A										

Remark:

1. Measuring frequencies from 1 GHz to the 10th harmonic of highest fundamental frequency.
2. Radiated emissions measured in frequency above 1000MHz were made with an instrument using peak/average detector mode.
3. Average test would be performed if the peak result were greater than the average limit or as required by the applicant.
4. Data of measurement within this frequency range shown " --- " in the table above means the reading of emissions are attenuated more than 20dB below the permissible limits or the field strength is too small to be measured.
5. Measurements above show only up to 6 maximum emissions noted, or would be lesser, with " N/A " remark, if no specific emissions from the EUT are recorded (ie: margin > 20dB from the applicable limit) and considered that's already beyond the background noise floor.
6. Margin (dB) = Remark result (dBuV/m) – Average limit (dBuV/m).

**Operation Mode:** TX / IEEE 802.11b / CH Mid**Test Date:** April 6, 2011**Temperature:** 24°C**Tested by:** Ali Shu**Humidity:** 50 % RH**Polarity:** Ver. / Hor.

Frequency (MHz)	Reading (Peak) (dBuV)	Reading (Average) (dBuV)	Correction Factor (dB/m)	Result (Peak) (dBuV/m)	Result (Average) (dBuV/m)	Limit (Peak) (dBuV/m)	Limit (Average) (dBuV/m)	Margin (dB)	Remark	Ant. Pol. (H/V)
2000.00	58.59	46.15	-5.47	53.12	40.68	74.00	54.00	-13.32	AVG	V
2176.67	59.10	47.54	-5.01	54.09	42.53	74.00	54.00	-11.47	AVG	V
2386.67	61.55	52.63	-4.33	57.22	48.30	74.00	54.00	-5.70	AVG	V
3258.33	50.88	---	-1.49	49.39	---	74.00	54.00	-4.61	Peak	V
4883.33	48.90	---	2.73	51.63	---	74.00	54.00	-2.37	Peak	V
N/A										
1523.33	58.03	---	-10.31	47.71	---	74.00	54.00	-6.29	Peak	H
2383.33	59.95	51.91	-4.35	55.60	47.56	74.00	54.00	-6.44	AVG	H
4425.00	48.29	---	1.74	50.02	---	74.00	54.00	-3.98	Peak	H
4908.33	49.08	38.94	2.78	51.86	41.72	74.00	54.00	-12.28	AVG	H
N/A										

Remark:

1. Measuring frequencies from 1 GHz to the 10th harmonic of highest fundamental frequency.
2. Radiated emissions measured in frequency above 1000MHz were made with an instrument using peak/average detector mode.
3. Average test would be performed if the peak result were greater than the average limit or as required by the applicant.
4. Data of measurement within this frequency range shown " --- " in the table above means the reading of emissions are attenuated more than 20dB below the permissible limits or the field strength is too small to be measured.
5. Measurements above show only up to 6 maximum emissions noted, or would be lesser, with " N/A " remark, if no specific emissions from the EUT are recorded (ie: margin > 20dB from the applicable limit) and considered that's already beyond the background noise floor.
6. Margin (dB) = Remark result (dBuV/m) – Average limit (dBuV/m).



Operation Mode: TX / IEEE 802.11b / CH High

Test Date: April 6, 2011

Temperature: 24°C

Tested by: Ali Shu

Humidity: 50 % RH

Polarity: Ver. / Hor.

Frequency (MHz)	Reading (Peak) (dBuV)	Reading (Average) (dBuV)	Correction Factor (dB/m)	Result (Peak) (dBuV/m)	Result (Average) (dBuV/m)	Limit (Peak) (dBuV/m)	Limit (Average) (dBuV/m)	Margin (dB)	Remark	Ant. Pol. (H/V)
2310.00	61.06	47.19	-4.65	56.41	42.54	74.00	54.00	-11.46	AVG	V
2406.67	59.93	52.35	-4.25	55.68	48.10	74.00	54.00	-5.90	AVG	V
4925.00	49.66	44.22	2.81	52.47	47.03	74.00	54.00	-6397	AVG	V
N/A										
1516.67	59.14	---	-10.38	48.76	---	74.00	54.00	-5.24	Peak	H
N/A										

Remark:

1. Measuring frequencies from 1 GHz to the 10th harmonic of highest fundamental frequency.
2. Radiated emissions measured in frequency above 1000MHz were made with an instrument using peak/average detector mode.
3. Average test would be performed if the peak result were greater than the average limit or as required by the applicant.
4. Data of measurement within this frequency range shown “ --- ” in the table above means the reading of emissions are attenuated more than 20dB below the permissible limits or the field strength is too small to be measured.
5. Measurements above show only up to 6 maximum emissions noted, or would be lesser, with “ N/A ” remark, if no specific emissions from the EUT are recorded (ie: margin>20dB from the applicable limit) and considered that's already beyond the background noise floor.
6. Margin (dB) = Remark result (dBuV/m) – Average limit (dBuV/m).



Operation Mode: TX / IEEE 802.11g / CH Low

Test Date: April 6, 2011

Temperature: 24°C

Tested by: Ali Shu

Humidity: 50 % RH

Polarity: Ver. / Hor.

Frequency (MHz)	Reading (Peak) (dBuV)	Reading (Average) (dBuV)	Correction Factor (dB/m)	Result (Peak) (dBuV/m)	Result (Average) (dBuV/m)	Limit (Peak) (dBuV/m)	Limit (Average) (dBuV/m)	Margin (dB)	Remark	Ant. Pol. (H/V)
1500.00	59.14	---	-10.55	48.59	---	74.00	54.00	-5.41	Peak	V
4866.67	49.29	---	2.69	51.98	---	74.00	54.00	-2.02	Peak	V
7558.33	48.06	34.21	7.31	55.37	41.52	74.00	54.00	-12.48	AVG	V
N/A										
1826.67	57.94	---	-7.23	50.71	---	74.00	54.00	-3.29	Peak	H
N/A										

Remark:

1. Measuring frequencies from 1 GHz to the 10th harmonic of highest fundamental frequency.
2. Radiated emissions measured in frequency above 1000MHz were made with an instrument using peak/average detector mode.
3. Average test would be performed if the peak result were greater than the average limit or as required by the applicant.
4. Data of measurement within this frequency range shown “ --- ” in the table above means the reading of emissions are attenuated more than 20dB below the permissible limits or the field strength is too small to be measured.
5. Measurements above show only up to 6 maximum emissions noted, or would be lesser, with “ N/A ” remark, if no specific emissions from the EUT are recorded (ie: margin > 20dB from the applicable limit) and considered that's already beyond the background noise floor.
6. Margin (dB) = Remark result (dBuV/m) – Average limit (dBuV/m).



Operation Mode: TX / IEEE 802.11g / CH Mid

Test Date: April 6, 2011

Temperature: 24°C

Tested by: Ali Shu

Humidity: 50 % RH

Polarity: Ver. / Hor.

Frequency (MHz)	Reading (Peak) (dBuV)	Reading (Average) (dBuV)	Correction Factor (dB/m)	Result (Peak) (dBuV/m)	Result (Average) (dBuV/m)	Limit (Peak) (dBuV/m)	Limit (Average) (dBuV/m)	Margin (dB)	Remark	Ant. Pol. (H/V)
1500.00	58.59	---	-10.55	48.04	---	74.00	54.00	-5.96	Peak	V
N/A										
1343.33	59.01	---	-10.71	48.30	---	74.00	54.00	-5.70	Peak	H
4108.33	49.51	---	0.80	50.31	---	74.00	54.00	-3.69	Peak	H
N/A										

Remark:

1. Measuring frequencies from 1 GHz to the 10th harmonic of highest fundamental frequency.
2. Radiated emissions measured in frequency above 1000MHz were made with an instrument using peak/average detector mode.
3. Average test would be performed if the peak result were greater than the average limit or as required by the applicant.
4. Data of measurement within this frequency range shown “ --- ” in the table above means the reading of emissions are attenuated more than 20dB below the permissible limits or the field strength is too small to be measured.
5. Measurements above show only up to 6 maximum emissions noted, or would be lesser, with “ N/A ” remark, if no specific emissions from the EUT are recorded (ie: margin > 20dB from the applicable limit) and considered that's already beyond the background noise floor.
6. Margin (dB) = Remark result (dBuV/m) – Average limit (dBuV/m).



Operation Mode: TX / IEEE 802.11g / CH High

Test Date: April 6, 2011

Temperature: 24°C

Tested by: Ali Shu

Humidity: 50 % RH

Polarity: Ver. / Hor.

Frequency (MHz)	Reading (Peak) (dBuV)	Reading (Average) (dBuV)	Correction Factor (dB/m)	Result (Peak) (dBuV/m)	Result (Average) (dBuV/m)	Limit (Peak) (dBuV/m)	Limit (Average) (dBuV/m)	Margin (dB)	Remark	Ant. Pol. (H/V)
1496.67	58.96	---	-10.55	48.41	---	74.00	54.00	-5.59	Peak	V
N/A										
1556.67	58.58	---	-9.97	48.61	---	74.00	54.00	-5.39	Peak	H
N/A										

Remark:

1. Measuring frequencies from 1 GHz to the 10th harmonic of highest fundamental frequency.
2. Radiated emissions measured in frequency above 1000MHz were made with an instrument using peak/average detector mode.
3. Average test would be performed if the peak result were greater than the average limit or as required by the applicant.
4. Data of measurement within this frequency range shown “ --- ” in the table above means the reading of emissions are attenuated more than 20dB below the permissible limits or the field strength is too small to be measured.
5. Measurements above show only up to 6 maximum emissions noted, or would be lesser, with “ N/A ” remark, if no specific emissions from the EUT are recorded (ie: margin>20dB from the applicable limit) and considered that's already beyond the background noise floor.
6. Margin (dB) = Remark result (dBuV/m) – Average limit (dBuV/m).



Operation Mode: TX / IEEE 802.11n HT 20 MHz mode / CH Low Test Date: April 6, 2011

Temperature: 24°C

Tested by: Ali Shu

Humidity: 50 % RH

Polarity: Ver. / Hor.

Frequency (MHz)	Reading (Peak) (dBuV)	Reading (Average) (dBuV)	Correction Factor (dB/m)	Result (Peak) (dBuV/m)	Result (Average) (dBuV/m)	Limit (Peak) (dBuV/m)	Limit (Average) (dBuV/m)	Margin (dB)	Remark	Ant. Pol. (H/V)
1686.67	57.81	---	-8.65	49.16	---	74.00	54.00	-4.84	Peak	V
3216.67	51.07	---	-1.60	49.47	---	74.00	54.00	-4.53	Peak	V
N/A										
1676.67	57.94	---	-8.76	49.19	---	74.00	54.00	-4.81	Peak	H
N/A										

Remark:

1. Measuring frequencies from 1 GHz to the 10th harmonic of highest fundamental frequency.
2. Radiated emissions measured in frequency above 1000MHz were made with an instrument using peak/average detector mode.
3. Average test would be performed if the peak result were greater than the average limit or as required by the applicant.
4. Data of measurement within this frequency range shown “ --- ” in the table above means the reading of emissions are attenuated more than 20dB below the permissible limits or the field strength is too small to be measured.
5. Measurements above show only up to 6 maximum emissions noted, or would be lesser, with “ N/A ” remark, if no specific emissions from the EUT are recorded (ie: margin>20dB from the applicable limit) and considered that's already beyond the background noise floor.
6. Margin (dB) = Remark result (dBuV/m) – Average limit (dBuV/m).



Operation Mode: TX / IEEE 802.11n HT 20 MHz mode / CH Mid Test Date: April 6, 2011

Temperature: 24°C

Tested by: Ali Shu

Humidity: 50 % RH

Polarity: Ver. / Hor.

Frequency (MHz)	Reading (Peak) (dBuV)	Reading (Average) (dBuV)	Correction Factor (dB/m)	Result (Peak) (dBuV/m)	Result (Average) (dBuV/m)	Limit (Peak) (dBuV/m)	Limit (Average) (dBuV/m)	Margin (dB)	Remark	Ant. Pol. (H/V)
1546.67	58.53	---	-10.08	48.46	---	74.00	54.00	-5.54	Peak	V
N/A										
1813.33	57.68	---	-7.37	50.32	---	74.00	54.00	-3.68	Peak	H
4150.00	49.74	---	0.92	50.66	---	74.00	54.00	-3.34	Peak	H
N/A										

Remark:

1. Measuring frequencies from 1 GHz to the 10th harmonic of highest fundamental frequency.
2. Radiated emissions measured in frequency above 1000MHz were made with an instrument using peak/average detector mode.
3. Average test would be performed if the peak result were greater than the average limit or as required by the applicant.
4. Data of measurement within this frequency range shown “ --- ” in the table above means the reading of emissions are attenuated more than 20dB below the permissible limits or the field strength is too small to be measured.
5. Measurements above show only up to 6 maximum emissions noted, or would be lesser, with “ N/A ” remark, if no specific emissions from the EUT are recorded (ie: margin > 20dB from the applicable limit) and considered that's already beyond the background noise floor.
6. Margin (dB) = Remark result (dBuV/m) – Average limit (dBuV/m).



Operation Mode: TX / IEEE 802.11n HT 20 MHz mode / CH High Test Date: April 6, 2011

Temperature: 24°C

Tested by: Ali Shu

Humidity: 50 % RH

Polarity: Ver. / Hor.

Frequency (MHz)	Reading (Peak) (dBuV)	Reading (Average) (dBuV)	Correction Factor (dB/m)	Result (Peak) (dBuV/m)	Result (Average) (dBuV/m)	Limit (Peak) (dBuV/m)	Limit (Average) (dBuV/m)	Margin (dB)	Remark	Ant. Pol. (H/V)
1493.33	58.06	---	-10.56	47.51	---	74.00	54.00	-6.49	Peak	V
5541.67	48.84	---	3.03	51.87	---	74.00	54.00	-2.13	Peak	V
N/A										
1990.00	58.85	46.05	-5.57	53.28	40.48	74.00	54.00	-13.52	AVG	H
N/A										

Remark:

1. Measuring frequencies from 1 GHz to the 10th harmonic of highest fundamental frequency.
2. Radiated emissions measured in frequency above 1000MHz were made with an instrument using peak/average detector mode.
3. Average test would be performed if the peak result were greater than the average limit or as required by the applicant.
4. Data of measurement within this frequency range shown " --- " in the table above means the reading of emissions are attenuated more than 20dB below the permissible limits or the field strength is too small to be measured.
5. Measurements above show only up to 6 maximum emissions noted, or would be lesser, with " N/A " remark, if no specific emissions from the EUT are recorded (ie: margin > 20dB from the applicable limit) and considered that's already beyond the background noise floor.
6. Margin (dB) = Remark result (dBuV/m) – Average limit (dBuV/m).



Operation Mode: TX / IEEE 802.11n HT 40 MHz mode / CH Low

Test Date: April 6, 2011

Temperature: 24°C

Tested by: Ali Shu

Humidity: 50 % RH

Polarity: Ver. / Hor.

Frequency (MHz)	Reading (Peak) (dBuV)	Reading (Average) (dBuV)	Correction Factor (dB/m)	Result (Peak) (dBuV/m)	Result (Average) (dBuV/m)	Limit (Peak) (dBuV/m)	Limit (Average) (dBuV/m)	Margin (dB)	Remark	Ant. Pol. (H/V)
1756.67	57.82	---	-7.94	49.88	---	74.00	54.00	-4.12	Peak	V
N/A										
1863.33	57.91	---	-6.86	51.05	---	74.00	54.00	-2.95	Peak	H
N/A										

Remark:

1. Measuring frequencies from 1 GHz to the 10th harmonic of highest fundamental frequency.
2. Radiated emissions measured in frequency above 1000MHz were made with an instrument using peak/average detector mode.
3. Average test would be performed if the peak result were greater than the average limit or as required by the applicant.
4. Data of measurement within this frequency range shown " --- " in the table above means the reading of emissions are attenuated more than 20dB below the permissible limits or the field strength is too small to be measured.
5. Measurements above show only up to 6 maximum emissions noted, or would be lesser; with " N/A " remark, if no specific emissions from the EUT are recorded (ie: margin > 20dB from the applicable limit) and considered that's already beyond the background noise floor.
6. Margin (dB) = Remark result (dBuV/m) – Average limit (dBuV/m).



Operation Mode: TX / IEEE 802.11n HT 40 MHz mode
/ CH Mid

Test Date: April 6, 2011

Temperature: 24°C

Tested by: Ali Shu

Humidity: 50 % RH

Polarity: Ver. / Hor.

Frequency (MHz)	Reading (Peak) (dBuV)	Reading (Average) (dBuV)	Correction Factor (dB/m)	Result (Peak) (dBuV/m)	Result (Average) (dBuV/m)	Limit (Peak) (dBuV/m)	Limit (Average) (dBuV/m)	Margin (dB)	Remark	Ant. Pol. (H/V)
1996.67	58.51	45.19	-5.50	53.00	39.69	74.00	54.00	-14.31	AVG	V
4958.33	48.96	---	2.88	51.84	---	74.00	54.00	-2.16	Peak	V
N/A										
1676.67	57.51	---	-8.76	48.76	---	74.00	54.00	-5.24	Peak	H
4883.33	48.74	---	2.73	51.47	---	74.00	54.00	-2.53	Peak	H
N/A										

Remark:

1. Measuring frequencies from 1 GHz to the 10th harmonic of highest fundamental frequency.
2. Radiated emissions measured in frequency above 1000MHz were made with an instrument using peak/average detector mode.
3. Average test would be performed if the peak result were greater than the average limit or as required by the applicant.
4. Data of measurement within this frequency range shown " --- " in the table above means the reading of emissions are attenuated more than 20dB below the permissible limits or the field strength is too small to be measured.
5. Measurements above show only up to 6 maximum emissions noted, or would be lesser; with " N/A " remark, if no specific emissions from the EUT are recorded (ie: margin > 20dB from the applicable limit) and considered that's already beyond the background noise floor.
6. Margin (dB) = Remark result (dBuV/m) – Average limit (dBuV/m).



Operation Mode: TX / IEEE 802.11n HT 40 MHz mode / CH High

Test Date: April 6, 2011

Temperature: 24°C

Tested by: Ali Shu

Humidity: 50 % RH

Polarity: Ver. / Hor.

Frequency (MHz)	Reading (Peak) (dBuV)	Reading (Average) (dBuV)	Correction Factor (dB/m)	Result (Peak) (dBuV/m)	Result (Average) (dBuV/m)	Limit (Peak) (dBuV/m)	Limit (Average) (dBuV/m)	Margin (dB)	Remark	Ant. Pol. (H/V)
1496.67	59.76	---	-10.55	49.21	---	74.00	54.00	-4.79	Peak	V
4858.33	49.25	---	2.68	51.92	---	74.00	54.00	-2.08	Peak	v
N/A										
1746.67	58.06	---	-8.04	50.01	---	74.00	54.00	-3.99	Peak	H
N/A										

Remark:

1. Measuring frequencies from 1 GHz to the 10th harmonic of highest fundamental frequency.
2. Radiated emissions measured in frequency above 1000MHz were made with an instrument using peak/average detector mode.
3. Average test would be performed if the peak result were greater than the average limit or as required by the applicant.
4. Data of measurement within this frequency range shown " --- " in the table above means the reading of emissions are attenuated more than 20dB below the permissible limits or the field strength is too small to be measured.
5. Measurements above show only up to 6 maximum emissions noted, or would be lesser; with " N/A " remark, if no specific emissions from the EUT are recorded (ie: margin>20dB from the applicable limit) and considered that's already beyond the background noise floor.
6. Margin (dB) = Remark result (dBuV/m) – Average limit (dBuV/m).



7.8 POWERLINE CONDUCTED EMISSIONS

LIMIT

According to §15.207(a), except as shown in paragraphs (b) and (c) of this section, for an intentional radiator that is designed to be connected to the public utility (AC) power line, the radio frequency voltage that is conducted back onto the AC power line on any frequency or frequencies within the band 150 kHz to 30 MHz shall not exceed the limits in the following table, as measured using a 50 μ H/50 ohms line impedance stabilization network (LISN). Compliance with the provisions of this paragraph shall be based on the measurement of the radio frequency voltage between each power line and ground at the power terminal. The lower limit applies at the boundary between the frequency ranges.

Frequency Range (MHz)	Limits (dB μ V)	
	Quasi-peak	Average
0.15 to 0.50	66 to 56*	56 to 46*
0.50 to 5	56	46
5 to 30	60	50

* Decreases with the logarithm of the frequency.

Test Configuration

See test photographs attached in Appendix II for the actual connections between EUT and support equipment.

TEST PROCEDURE

1. The EUT was placed on a table, which is 0.8m above ground plane.
2. Maximum procedure was performed on the six highest emissions to ensure EUT compliance.
3. Repeat above procedures until all frequency measured were complete.



TEST RESULTS

The initial step in collecting conducted data is a spectrum analyzer peak scan of the measurement range. Significant peaks are then marked as shown on the following data page, and these signals are then quasi-peaked.

Test Data

Operation Mode: Normal Link **Test Date:** April 18, 2011
Temperature: 26°C **Tested by:** David Lee
Humidity: 60% RH

Freq. (MHz)	QP Reading (dBuV)	AV Reading (dBuV)	Corr. factor (dB/m)	QP Result (dBuV/m)	AV Result (dBuV/m)	QP Limit (dBuV)	AV Limit (dBuV)	QP Margin (dB)	AV Margin (dB)	Note
0.1700	44.03	20.53	0.17	44.20	20.70	64.96	54.96	-20.76	-34.26	L1
0.1731	43.83	20.13	0.17	44.00	20.30	64.81	54.81	-20.81	-34.51	L1
0.2700	46.44	32.84	0.16	46.60	33.00	61.12	51.12	-14.52	-18.12	L1
3.0900	32.76	23.36	0.24	33.00	23.60	56.00	46.00	-23.00	-22.40	L1
14.1100	36.05	26.85	0.55	36.60	27.40	60.00	50.00	-23.40	-22.60	L1
23.1400	33.98	27.28	0.72	34.70	28.00	60.00	50.00	-25.30	-22.00	L1
0.2600	41.05	31.15	0.25	41.30	31.40	61.43	51.43	-20.13	-20.03	L2
0.9200	35.64	29.14	0.26	35.90	29.40	56.00	46.00	-20.10	-16.60	L2
1.8400	29.13	18.53	0.27	29.40	18.80	56.00	46.00	-26.60	-27.20	L2
3.5300	31.90	22.50	0.30	32.20	22.80	56.00	46.00	-23.80	-23.20	L2
14.0300	34.58	24.98	0.52	35.10	25.50	60.00	50.00	-24.90	-24.50	L2
23.8900	29.89	23.39	0.71	30.60	24.10	60.00	50.00	-29.40	-25.90	L2

Remark:

1. Measuring frequencies from 0.15 MHz to 30MHz.
2. The emissions measured in frequency range from 0.15 MHz to 30MHz were made with an instrument using Quasi-peak detector and average detector.
3. The IF bandwidth of SPA between 0.15MHz and 30MHz was 10 kHz; the IF bandwidth of Test Receiver between 0.15MHz and 30MHz was 9 kHz;
4. L1 = Line One (Live Line) / L2 = Line Two (Neutral Line)



Test Plots

Conducted emissions (Line 1)



Conducted emissions (Line 2)

