

920287B remote-control Antenna Diagrams Ant10

Pictures



picture Ant_10

Antenna diagram 315 MHz horizontal polarisation Ant_10 [dBi]

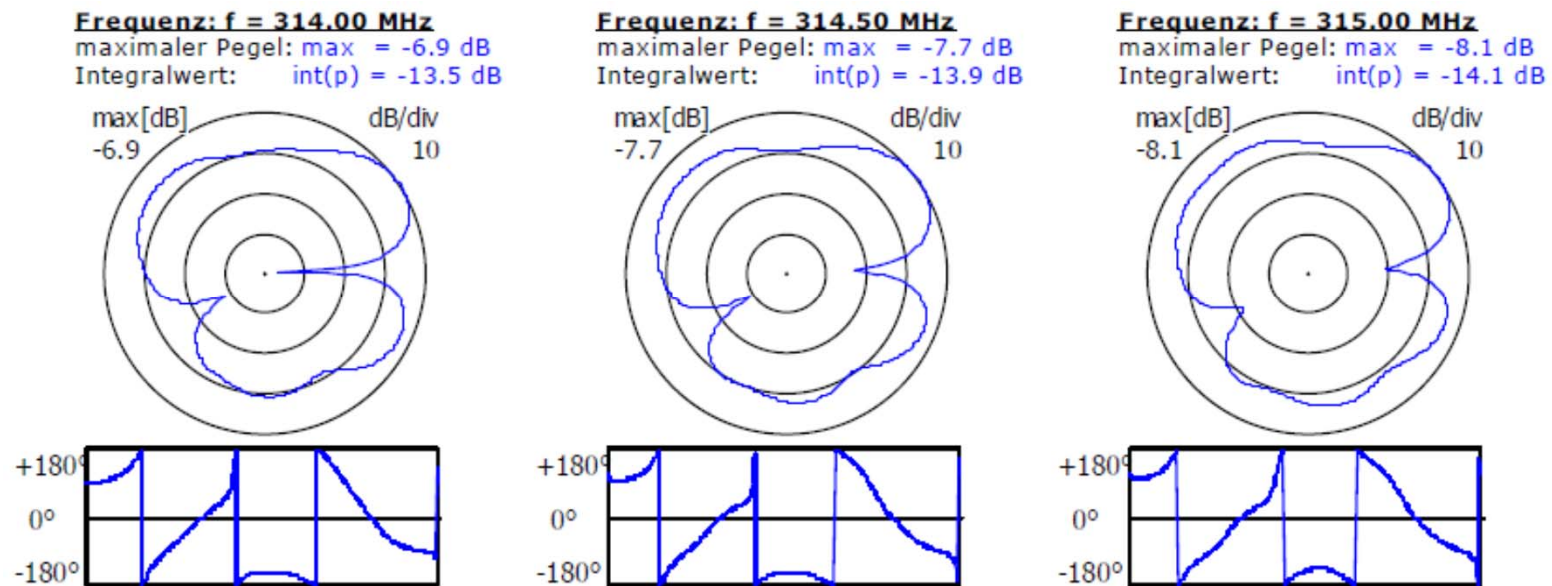

Antenna diagram 315 MHz vertical polarisation Ant_10 [dBi]

Frequenz: f = 314.00 MHz
 maximaler Pegel: max = 0.3 dB
 Integralwert: int(p) = -3.7 dB

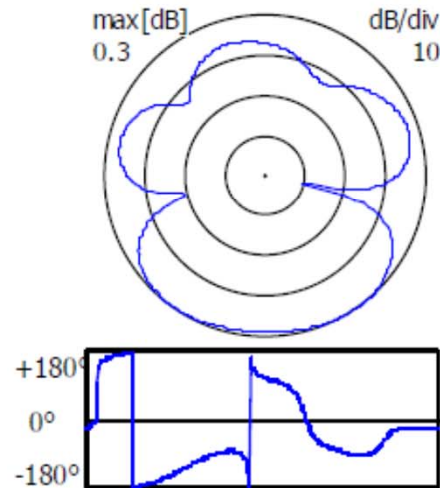

Frequenz: f = 314.50 MHz
 maximaler Pegel: max = 0.5 dB
 Integralwert: int(p) = -3.5 dB

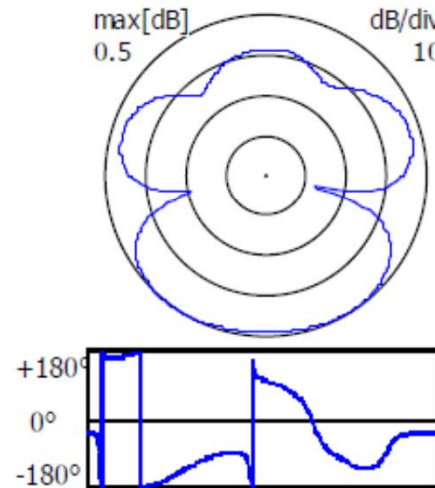

Frequenz: f = 315.00 MHz
 maximaler Pegel: max = 0.7 dB
 Integralwert: int(p) = -3.7 dB

