

FCC Test Report

Product Name	Software defined radio
Model No.	SDR-2400, SM-SDR-2400
FCC ID.	XTC-SDR2400

Applicant	Lilee Systems, Ltd.
Address	91 East Tasman Drive Suite 150, San Jose, California 95134, United States

Date of Receipt	Nov. 16, 2018
Issued Date	Mar. 04, 2019
Report No.	18B0256R-RFUSP26V00
Report Version	V1.0



The test results relate only to the samples tested.

The test results shown in the test report are traceable to the national/international standard through the calibration report of the equipment and evaluated measurement uncertainty herein.

This report must not be used to claim product endorsement by TAF or any agency of the government.

The test report shall not be reproduced without the written approval of DEKRA Testing and Certification Co., Ltd.

Test Report

Issued Date: Mar. 04, 2019

Report No.: 18B0256R-RFUSP26V00



Product Name	Software defined radio
Applicant	Lilee Systems, Ltd.
Address	91 East Tasman Drive Suite 150, San Jose, California 95134, United States
Manufacturer	Lilee Systems, Ltd.
Model No.	SDR-2400, SM-SDR-2400
FCC ID.	XTC-SDR2400
EUT Rated Voltage	DC 12V and DC 3.3V
EUT Test Voltage	DC 12V and DC 3.3V
Trade Name	
Applicable Standard	FCC CFR Title 47 Part 15 Subpart C: 2017 ANSI C63.4: 2014, ANSI C63.10: 2013 KDB 558074 D01 15.247 Meas Guidance v05
Test Result	Complied

Documented By :

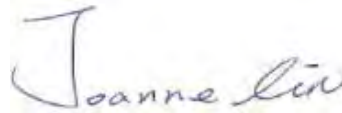

(Senior Adm. Specialist / Joanne Lin)

Tested By :

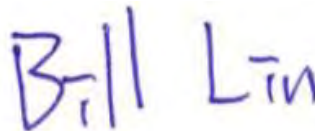

(Senior Engineer / Bill Lin)

Approved By :



(Director / Vincent Lin)

TABLE OF CONTENTS

Description	Page
1. GENERAL INFORMATION	4
1.1. EUT Description.....	4
1.2. Operational Description.....	6
1.3. Tested System Details.....	7
1.4. Configuration of Tested System	7
1.5. EUT Exercise Software	7
1.6. Test Facility	8
1.7. List of Test Equipment.....	9
2. CONDUCTED EMISSION	10
2.1. Test Setup	10
2.2. Limits.....	10
2.3. Test Procedure	11
2.4. Uncertainty	11
2.5. Test Result of Conducted Emission.....	12
3. PEAK POWER OUTPUT	13
3.1. Test Setup	13
3.2. Limit	13
3.3. Test Procedure	13
3.4. Uncertainty	13
3.5. Test Result of Peak Power Output	14
4. RADIATED EMISSION	22
4.1. Test Setup	22
4.2. Limits.....	23
4.3. Test Procedure	24
4.4. Uncertainty	25
4.5. Test Result of Radiated Emission	26
5. RF ANTENNA CONDUCTED TEST	74
5.1. Test Setup	74
5.2. Limits.....	74
5.3. Test Procedure	74
5.4. Uncertainty	74
5.5. Test Result of RF Antenna Conducted Test	75
6. BAND EDGE	99
6.1. Test Setup	99
6.2. Limit	100
6.3. Test Procedure	100
6.4. Uncertainty	101
6.5. Test Result of Band Edge	102
7. 6DB BANDWIDTH	150
7.1. Test Setup	150
7.2. Limits.....	150
7.3. Test Procedure	150
7.4. Uncertainty	150
7.5. Test Result of 6dB Bandwidth.....	151
8. POWER DENSITY	181
8.1. Test Setup	181
8.2. Limits.....	181
8.3. Test Procedure	181
8.4. Uncertainty	181
8.5. Test Result of Power Density	182
9. DUTY CYCLE	212
9.1. Test Setup	212
9.2. Test Procedure	212
9.3. Uncertainty	212
9.4. Test Result of Duty Cycle.....	213
10. EMI REDUCTION METHOD DURING COMPLIANCE TESTING	215
Attachment 1: EUT Test Photographs	
Attachment 2: EUT Detailed Photographs	

1. GENERAL INFORMATION

1.1. EUT Description

Product Name	Software defined radio
Trade Name	
Model No.	SDR-2400, SM-SDR-2400
FCC ID.	XTC-SDR2400
Frequency Range	2412-2462MHz
Channel Number	11
Channel bandwidth:	20 MHz
Channel separation	5 MHz
Data rate	Up to 200 Mbps.
Type of Modulation	OFDM (BPSK, QPSK, 16-QAM, 64-QAM)
Antenna Type	Dipole Antenna · Patch Antenna
Channel Control	Auto
Antenna Gain	Refer to the table “Antenna List”

Antenna List

No.	Manufacturer	Part No.	Antenna Type	Peak Gain
1	JOYMAX ELECTRONICS	IAF-6491RS5X-991	Dipole	2dBi for 2.4 GHz
2	JOYMAX ELECTRONICS	IPX-026XNFX9-999	Patch	13dBi for 2.4 GHz

Note: The antenna of EUT is conforming to FCC 15.203.

Center Frequency of Each Channel:

Channel	Frequency	Channel	Frequency	Channel	Frequency	Channel	Frequency
Channel 01:	2412 MHz	Channel 02:	2417 MHz	Channel 03:	2422 MHz	Channel 04:	2427 MHz
Channel 05:	2432 MHz	Channel 06:	2437 MHz	Channel 07:	2442 MHz	Channel 08:	2447 MHz
Channel 09:	2452 MHz	Channel 10:	2457 MHz	Channel 11:	2462 MHz		

Note:

1. The EUT is a Software defined radio with built-in 2.4G transceiver.
2. These tests were conducted on a sample for the purpose of demonstrating compliance of 2.4G transmitter with Part 15 Subpart C Paragraph 15.247 for spread spectrum devices.
3. Regarding to the operation frequency, the lowest, middle and highest frequency are selected to perform the test.
4. The EUT is including two models for different marketing requirement and the different of each model is shown as below:

Model Number	SDR-2400	SM-SDR-2400
Product Name	Software defined radio	
Trade Name	LILEE SYSTEMS	
Appearance Difference	Have no from panel and top cover	Have from panel and top cover

5. The radiation measurements are performed in X, Y, Z axis positioning. Only the worst case is shown in the report.
6. The EUT can only configure MIMO mode: 2x2 (A1+A2 or B1+B2), 4x4(A1+A2+B1+B2), and the port is defined as follows:

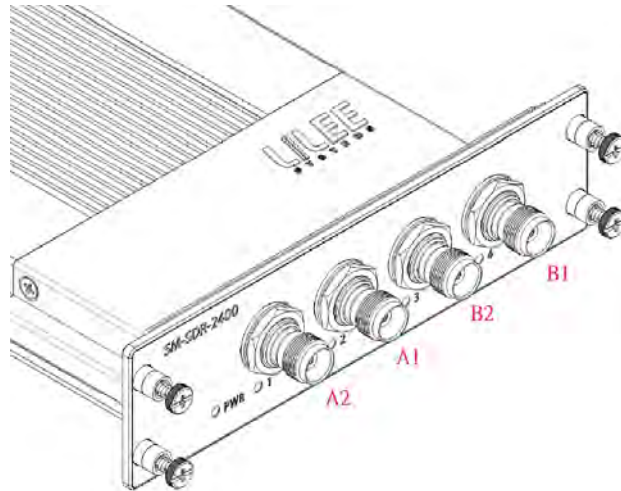

Test Mode	Mode 1: Transmit_Dipole (A1+ A2)
	Mode 1: Transmit_Dipole (A1+ A2+ B1+ B2)
	Mode 1: Transmit_Dipole (B1+ B2)
	Mode 2: Transmit_Patch (A1+ A2)
	Mode 2: Transmit_Patch (A1+ A2+ B1+ B2)
	Mode 2: Transmit_Patch (B1+ B2)

1.3. Tested System Details

The types for all equipment, plus descriptions of all cables used in the tested system (including inserted cards) are:

Product	Manufacturer	Model No.	Serial No.	Power Cord
1	Test Fixture	LILEE SYSTEMS	N/A	N/A

Signal Cable Type	Signal cable Description
N/A	

1.4. Configuration of Tested System

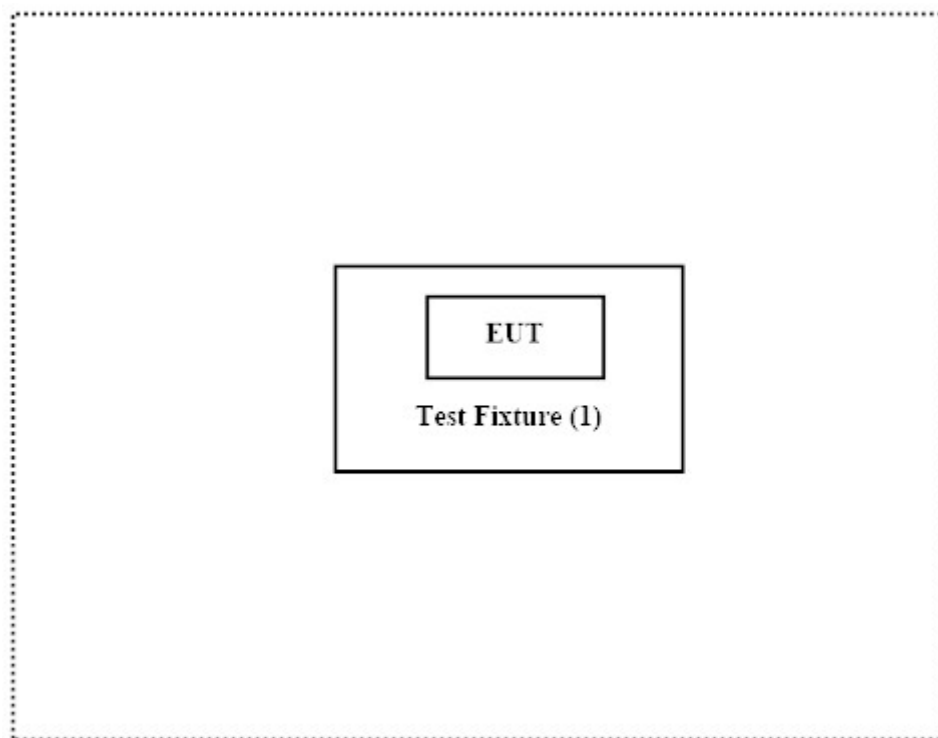

1.5. EUT Exercise Software

1. Setup the EUT as shown in Section 1.4.
2. Execute software "Putty Configuration Release 0.64" on the Notebook PC.
3. Configure the test mode, the test channel, and the data rate.
4. Press "OK" to start the continuous Transmit.
5. Verify that the EUT works properly.
6. Remove the Notebook PC

1.6. Test Facility

Ambient conditions in the laboratory:

Items	Required (IEC 68-1)	Actual
Temperature (°C)	15-35	20-35
Humidity (%RH)	25-75	50-65
Barometric pressure (mbar)	860-1060	950-1000

The related certificate for our laboratories about the test site and management system can be downloaded from DEKRA Testing and Certification Co., Ltd. Web Site:

<http://www.dekra.com.tw/english/about/certificates.aspx?bval=5>

The address and introduction of DEKRA Testing and Certification Co., Ltd. laboratories can be founded in our Web site: http://www.dekra.com.tw/index_en

Site Description: Accredited by TAF
Accredited Number: 3023

Site Name: DEKRA Testing and Certification Co., Ltd.
Site Address: No.159, Sec. 2, Wenhua 1st Rd., Linkou Dist.,
New Taipei City 24457, Taiwan.
TEL: 886-2-2602-7968 / FAX : 866-2-2602-3286
E-Mail : info.tw@dekra.com

FCC Accreditation Number: TW0023

1.7. List of Test Equipment

For Conduction measurements /ASR1

	Equipment	Manufacturer	Model No.	Serial No.	Cali. Data	Due. Data
X	EMI Test Receiver	R&S	ESR7	101602	2018.12.17	2019.12.16
X	Two-Line V-Network	R&S	ENV216	101306	2018.03.09	2019.03.08
X	Two-Line V-Network	R&S	ENV216	101307	2018.03.20	2019.03.19
X	Coaxial Cable	Quietek	RG400_BNC	RF001	2018.05.24	2019.05.23

Note:

1. All equipments are calibrated every one year.
2. The test instruments marked with "X" are used to measure the final test results.
3. Test Software version : QuieTek EMI 2.0 V2.1.113

For Conducted measurements /ASR4

	Equipment	Manufacturer	Model No.	Serial No.	Cali. Data	Due. Data
X	Spectrum Analyzer	R&S	FSV30	103464	2019.01.25	2020.01.24
X	Power Meter	Anritsu	ML2496A	1548003	2018.12.19	2019.12.18
X	Power Sensor	Anritsu	MA2411B	1531024	2018.12.19	2019.12.18
X	Power Sensor	Anritsu	MA2411B	1531025	2018.12.19	2019.12.18
	Bluetooth Tester	R&S	CBT	101238	2019.01.21	2020.01.20

Note:

1. All equipments are calibrated every one year.
2. The test instruments marked with "X" are used to measure the final test results.
3. Test Software version : DEKRA Conduction Test System V9.0.1

For Radiated measurements /ACB1

	Equipment	Manufacturer	Model No.	Serial No.	Cali. Data	Due. Data
X	Loop Antenna	TESEQ	HLA6121	49611	2019.02.22	2020.02.21
X	Bi-Log Antenna	SCHWARZBECK	VULB9168	9168-674	2018.04.02	2019.04.01
X	Horn Antenna	ETS-Lindgren	3117	00203800	2018.12.11	2019.12.10
X	Horn Antenna	Com-Power	AH-840	101087	2018.06.01	2019.05.31
X	Pre-Amplifier	EMCI	EMC001330	980316	2018.06.01	2019.05.31
X	Pre-Amplifier	EMCI	EMC051835SE	980311	2018.06.04	2019.06.03
X	Pre-Amplifier	EMCI	EMC05820SE	980310	2018.06.04	2019.06.03
X	Pre-Amplifier	EMCI	EMC184045SE	980314	2018.05.16	2019.05.15
X	Filter	MICRO TRONICS	BRM50702	G251	2018.09.04	2019.09.03
	Filter	MICRO TRONICS	BRM50716	G188	2018.09.04	2019.09.03
X	EMI Test Receiver	R&S	ESR7	101602	2018.12.17	2019.12.16
X	Spectrum Analyzer	R&S	FSV40	101148	2019.02.20	2020.02.19
X	Coaxial Cable	SUHNER	SUCOFLEX 106	RF002	2018.05.25	2019.05.24
X	Mircoflex Cable	HUBER SUHNER	SUCOFLEX 102	MY3381/2	2018.05.16	2019.05.15

Note:

1. Loop Antenna is calibrated every two year, the other equipments are calibrated every one year.
2. The test instruments marked with "X" are used to measure the final test results.
3. Test Software version : QuieTek EMI 2.0 V2.1.113

2. Conducted Emission

2.1. Test Setup

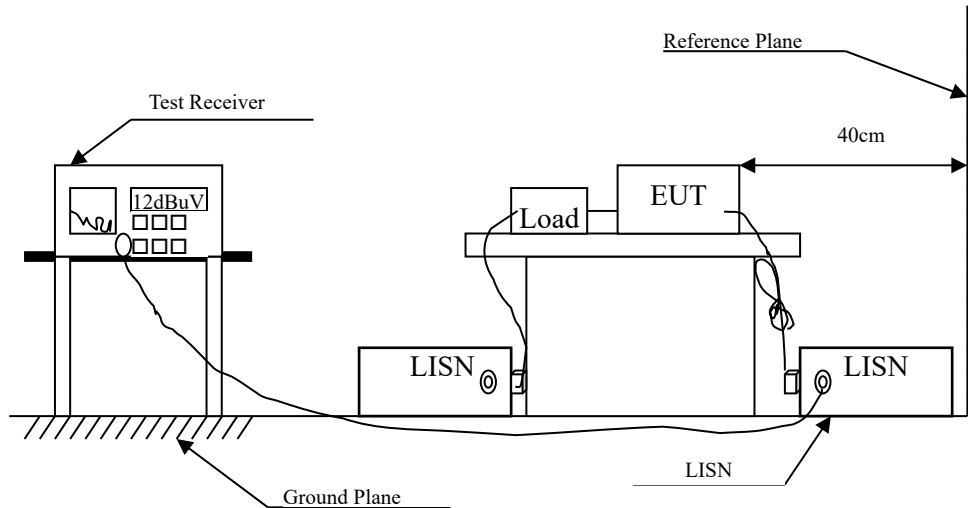

2.2. Limits

FCC Part 15 Subpart C Paragraph 15.207 (dBuV) Limit		
Frequency MHz	Limits	
	QP	AV
0.15 - 0.50	66-56	56-46
0.50-5.0	56	46
5.0 - 30	60	50

Remarks: In the above table, the tighter limit applies at the band edges.

2.3. Test Procedure

The EUT and Peripherals are connected to the main power through a line impedance stabilization network (L.I.S.N.). This provides a 50 ohm /50uH coupling impedance for the measuring equipment. The peripheral devices are also connected to the main power through a LISN that provides a 50ohm /50uH coupling impedance with 50ohm termination. (Please refer to the block diagram of the test setup and photographs.)

Both sides of A.C. line are checked for maximum conducted interference. In order to find the maximum emission, the relative positions of equipment and all the interface cables must be changed according to ANSI C63.4: 2014 on conducted measurement.

Conducted emissions were investigated over the frequency range from 0.15MHz to 30MHz using a receiver bandwidth of 9kHz.

The EUT was setup to ANSI C63.4, 2014; tested to DTS test procedure of FCC KDB-558074 for compliance to FCC 47CFR Subpart C requirements.

2.4. Uncertainty

±2.35dB

2.5. Test Result of Conducted Emission

Owing to the EUT use DC supply voltage, this test item is not performed.

3. Peak Power Output

3.1. Test Setup

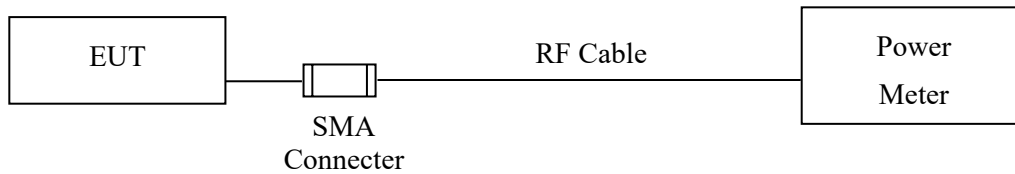

3.2. Limit

The maximum peak power shall be less 1Watt.

3.3. Test Procedure

Tested according to DTS test procedure of KDB 558074 for compliance to FCC 47CFR 15.247 requirements. The maximum peak conducted output power using KDB 558074 section 8.3.1.3 PKPM1 Peak power meter method.

3.4. Uncertainty

± 0.86 dB

3.5. Test Result of Peak Power Output

Product : Software defined radio
 Test Item : Peak Power Output
 Test Mode : Mode 1: Transmit_Dipole (A1+ A2)
 Test Date : 2017/12/07

Chain A1:

Channel No	Frequency (MHz)	Peak Power Output (dBm)						
		Average Power				Peak Power	Required Limit	Result
		For different Data Rate (Mbps)						
5.01	15.20	30.40	45.60	5.01				
01	2412	17.80	--	--	--	26.31	<30dBm	Pass
06	2437	17.58	17.43	17.35	17.29	26.24	<30dBm	Pass
11	2462	17.54	--	--	--	26.57	<30dBm	Pass

Note: Peak Power Output Value =Reading value on power meter + cable loss

Chain A2:

Channel No	Frequency (MHz)	Peak Power Output (dBm)						
		Average Power				Peak Power	Required Limit	Result
		For different Data Rate (Mbps)						
5.01	15.20	30.40	45.60	5.01				
01	2412	17.40	--	--	--	26.47	<30dBm	Pass
06	2437	17.62	17.54	17.42	17.33	26.49	<30dBm	Pass
11	2462	17.68	--	--	--	26.36	<30dBm	Pass

Note: Peak Power Output Value =Reading value on power meter + cable loss

Chain A1+A2:

Channel	Frequency (MHz)	Data Rate (Mbps)	Chain A1 Power (dBm)	Chain A2 Power (dBm)	Chain A1+A2 Power (dBm)	Limit (dBm)	Result
01	2412	HT8	26.31	26.47	29.40	<30dBm	Pass
06	2437	HT8	26.24	26.49	29.38	<30dBm	Pass
11	2462	HT8	26.57	26.36	29.48	<30dBm	Pass

Note: Peak Power Output Value (dBm) = 10*LOG (Chain A1 (mW)+ Chain A2 (mW))

Product : Software defined radio
 Test Item : Peak Power Output
 Test Mode : Mode 1: Transmit_Dipole (A1+ A2+ B1+ B2)
 Test Date : 2017/12/07

Chain A1:

Channel No	Frequency (MHz)	Peak Power Output (dBm)						
		Average Power For different Data Rate (Mbps)				Peak Power	Required Limit	Result
		22.20	66.80	133.80	200.6			
01	2412	13.39	--	--	--	23.47	<30dBm	Pass
06	2437	13.94	13.85	13.76	13.64	24.05	<30dBm	Pass
11	2462	14.13	--	--	--	24.33	<30dBm	Pass

Note: Peak Power Output Value =Reading value on power meter + cable loss

Chain A2:

Channel No	Frequency (MHz)	Peak Power Output (dBm)						
		Average Power For different Data Rate (Mbps)				Peak Power	Required Limit	Result
		22.20	66.80	133.80	200.6			
01	2412	13.15	--	--	--	23.18	<30dBm	Pass
06	2437	14.10	13.96	13.84	13.72	23.5	<30dBm	Pass
11	2462	13.91	--	--	--	23.49	<30dBm	Pass

Note: Peak Power Output Value =Reading value on power meter + cable loss

Chain B1:

Channel No	Frequency (MHz)	Peak Power Output (dBm)						
		Average Power For different Data Rate (Mbps)				Peak Power	Required Limit	Result
		22.20	66.80	133.80	200.6			
01	2412	12.97	--	--	--	23.37	<30dBm	Pass
06	2437	14.25	14.14	14.08	13.91	24.40	<30dBm	Pass
11	2462	14.33	--	--	--	24.23	<30dBm	Pass

Note: Peak Power Output Value =Reading value on power meter + cable loss

Chain B2:

Channel No	Frequency (MHz)	Peak Power Output (dBm)						
		Average Power For different Data Rate (Mbps)				Peak Power	Required Limit	Result
		22.20	66.80	133.80	200.6			
01	2412	12.55	--	--	--	22.13	<30dBm	Pass
06	2437	13.38	13.29	13.17	13.08	23.04	<30dBm	Pass
11	2462	13.25	--	--	--	23.04	<30dBm	Pass

Note: Peak Power Output Value =Reading value on power meter + cable loss

Chain A1+A2+B1+B2:

Channel	Frequency (MHz)	Data Rate (Mbps)	Chain A1 Power (dBm)	Chain A2 Power (dBm)	Chain B1 Power (dBm)	Chain B2 Power (dBm)	Chain A1+A2+B1+B2 Power (dBm)	Limit (dBm)	Result
01	2412	HT24	23.47	23.18	23.37	22.13	29.09	<30dBm	Pass
06	2437	HT24	24.05	23.50	24.40	23.04	29.80	<30dBm	Pass
11	2462	HT24	24.33	23.49	24.23	23.04	29.83	<30dBm	Pass

Note: Peak Power Output Value (dBm) = 10*LOG (Chain A1 (mW)+Chain A2 (mW)+Chain B1 (mW)+Chain B2 (mW))

Product : Software defined radio
 Test Item : Peak Power Output
 Test Mode : Mode 1: Transmit_Dipole (B1+ B2)
 Test Date : 2017/12/07

Chain B1:

Channel No	Frequency (MHz)	Peak Power Output (dBm)						
		Average Power For different Data Rate (Mbps)				Peak Power	Required Limit	Result
		5.01	15.20	30.40	45.60			
01	2412	17.56	--	--	--	26.65	<30dBm	Pass
06	2437	17.33	17.26	17.13	17.08	26.80	<30dBm	Pass
11	2462	17.43	--	--	--	26.78	<30dBm	Pass

Note: Peak Power Output Value =Reading value on power meter + cable loss

Chain B2:

Channel No	Frequency (MHz)	Peak Power Output (dBm)						
		Average Power For different Data Rate (Mbps)				Peak Power	Required Limit	Result
		5.01	15.20	30.40	45.60			
01	2412	16.77	--	--	--	26.31	<30dBm	Pass
06	2437	16.91	16.85	16.74	16.61	26.29	<30dBm	Pass
11	2462	16.64	--	--	--	26.09	<30dBm	Pass

Note: Peak Power Output Value =Reading value on power meter + cable loss

Chain B1+B2:

Channel	Frequency (MHz)	Data Rate (Mbps)	Chain B1 Power (dBm)	Chain B2 Power (dBm)	Chain B1+B2 Power (dBm)	Limit (dBm)	Result
01	2412	HT8	26.65	26.31	29.49	<30dBm	Pass
06	2437	HT8	26.80	26.29	29.56	<30dBm	Pass
11	2462	HT8	26.78	26.09	29.46	<30dBm	Pass

Note: Peak Power Output Value (dBm) = 10*LOG (Chain B1 (mW)+ Chain B2 (mW))

Product : Software defined radio
 Test Item : Peak Power Output
 Test Mode : Mode 2: Transmit_Patch (A1+ A2)
 Test Date : 2018/01/10

Chain A1:

Channel No	Frequency (MHz)	Peak Power Output (dBm)						Required Limit	Result
		Average Power				Peak Power			
		For different Data Rate (Mbps)							
5.01	15.20	30.40	45.60	5.01					
01	2412	7.29	--	--	--	17.23	<23dBm	Pass	
06	2437	9.39	9.24	9.16	9.07	19.82	<23dBm	Pass	
11	2462	8.73	--	--	--	18.52	<23dBm	Pass	

Note: 1.Peak Power Output Value =Reading value on power meter + cable loss

2.Limit = 30dBm – (Ant Gain-6) ; 30dBm – (13-6) = 23dBm

Chain A2:

Channel No	Frequency (MHz)	Peak Power Output (dBm)						Required Limit	Result
		Average Power				Peak Power			
		For different Data Rate (Mbps)							
5.01	15.20	30.40	45.60	5.01					
01	2412	8.37	--	--	--	17.46	<23dBm	Pass	
06	2437	10.18	10.05	9.93	9.84	19.89	<23dBm	Pass	
11	2462	9.30	--	--	--	18.88	<23dBm	Pass	

Note: 1.Peak Power Output Value =Reading value on power meter + cable loss

2.Limit = 30dBm – (Ant Gain-6) ; 30dBm – (13-6) = 23dBm

Chain A1+A2:

Channel	Frequency (MHz)	Data Rata (Mbps)	Chain A1 Power (dBm)	Chain A2 Power (dBm)	Chain A1+A2 Power (dBm)	Limit (dBm)	Result
01	2412	HT8	17.23	17.46	20.36	<23dBm	Pass
06	2437	HT8	19.82	19.89	22.87	<23dBm	Pass
11	2462	HT8	18.52	18.88	21.71	<23dBm	Pass

Note: 1.Peak Power Output Value (dBm) = 10*LOG (Chain A1 (mW)+ Chain A2 (mW))

2.Limit = 30dBm – (Ant Gain-6) ; 30dBm – (13-6) = 23dBm

Product : Software defined radio
 Test Item : Peak Power Output
 Test Mode : Mode 2: Transmit_Patch (A1+ A2+ B1+ B2)
 Test Date : 2018/01/10

Chain A1:

Channel No	Frequency (MHz)	Peak Power Output (dBm)							
		Average Power For different Data Rate (Mbps)				Peak Power	Required Limit	Result	
		22.20	66.80	133.80	200.6				
01	2412	6.18	--	--	--	22.20	16.59	<23dBm	Pass
06	2437	6.14	6.05	5.94	5.73	22.20	16.66	<23dBm	Pass
11	2462	6.13	--	--	--	22.20	16.53	<23dBm	Pass

Note: 1. Peak Power Output Value = Reading value on power meter + cable loss
 2. Limit = 30dBm – (Ant Gain-6) ; 30dBm – (13-6) = 23dBm

Chain A2:

Channel No	Frequency (MHz)	Peak Power Output (dBm)							
		Average Power For different Data Rate (Mbps)				Peak Power	Required Limit	Result	
		22.20	66.80	133.80	200.6				
01	2412	6.92	--	--	--	22.20	16.42	<23dBm	Pass
06	2437	6.87	6.76	6.68	6.53	22.20	16.34	<23dBm	Pass
11	2462	6.73	--	--	--	22.20	16.26	<23dBm	Pass

Note: 1. Peak Power Output Value = Reading value on power meter + cable loss
 2. Limit = 30dBm – (Ant Gain-6) ; 30dBm – (13-6) = 23dBm

Chain B1:

Channel No	Frequency (MHz)	Peak Power Output (dBm)							
		Average Power For different Data Rate (Mbps)				Peak Power	Required Limit	Result	
		22.20	66.80	133.80	200.6				
01	2412	6.89	--	--	--	22.20	16.86	<23dBm	Pass
06	2437	6.53	6.42	6.33	6.29	22.20	16.60	<23dBm	Pass
11	2462	6.88	--	--	--	22.20	16.56	<23dBm	Pass

Note: 1. Peak Power Output Value = Reading value on power meter + cable loss
 2. Limit = 30dBm – (Ant Gain-6) ; 30dBm – (13-6) = 23dBm

Chain B2:

Channel No	Frequency (MHz)	Peak Power Output (dBm)							
		Average Power For different Data Rate (Mbps)				Peak Power	Required Limit	Result	
		22.20	66.80	133.80	200.6				
01	2412	6.00	--	--	--	22.20	15.26	<23dBm	Pass
06	2437	6.09	5.91	5.86	5.74	22.20	15.75	<23dBm	Pass
11	2462	5.79	--	--	--	22.20	15.48	<23dBm	Pass

Note: 1. Peak Power Output Value = Reading value on power meter + cable loss
 2. Limit = 30dBm – (Ant Gain-6) ; 30dBm – (13-6) = 23dBm

Chain A1+A2+B1+B2:

Channel	Frequency (MHz)	Data Rate (Mbps)	Chain A1 Power (dBm)	Chain A2 Power (dBm)	Chain B1 Power (dBm)	Chain B2 Power (dBm)	Chain A1+A2+B1+B2 Power (dBm)	Limit (dBm)	Result
01	2412	HT24	16.59	16.42	16.86	15.26	22.34	<23dBm	Pass
06	2437	HT24	16.66	16.34	16.60	15.75	22.37	<23dBm	Pass
11	2462	HT24	16.53	16.26	16.56	15.48	22.25	<23dBm	Pass

Note:

1. Peak Power Output Value (dBm) = 10*LOG (Chain A1 (mW)+Chain A2 (mW)+Chain B1 (mW)+Chain B2 (mW))
2. Limit = 30dBm – (Ant Gain-6) ; 30dBm – (13-6) = 23dBm

Product : Software defined radio
 Test Item : Peak Power Output
 Test Mode : Mode 2: Transmit_Patch (B1+ B2)
 Test Date : 2018/01/10

Chain B1:

Channel No	Frequency (MHz)	Peak Power Output (dBm)						
		Average Power For different Data Rate (Mbps)				Peak Power	Required Limit	Result
		5.01	15.20	30.40	45.60			
01	2412	7.35	--	--	--	17.40	<23dBm	Pass
06	2437	10.41	10.32	10.25	10.16	20.35	<23dBm	Pass
11	2462	8.22	--	--	--	18.58	<23dBm	Pass

Note: Peak Power Output Value =Reading value on power meter + cable loss

Chain B2:

Channel No	Frequency (MHz)	Peak Power Output (dBm)						
		Average Power For different Data Rate (Mbps)				Peak Power	Required Limit	Result
		5.01	15.20	30.40	45.60			
01	2412	6.75	--	--	--	16.34	<23dBm	Pass
06	2437	10.02	9.91	9.83	9.74	19.31	<23dBm	Pass
11	2462	7.79	--	--	--	17.07	<23dBm	Pass

Note: Peak Power Output Value =Reading value on power meter + cable loss

Chain B1+B2:

Channel	Frequency (MHz)	Data Rata (Mbps)	Chain B1 Power (dBm)	Chain B2 Power (dBm)	Chain B1+B2 Power (dBm)	Limit (dBm)	Result
01	2412	HT8	17.40	16.34	19.91	<23dBm	Pass
06	2437	HT8	20.35	19.31	22.87	<23dBm	Pass
11	2462	HT8	18.58	17.07	20.90	<23dBm	Pass

Note: 1.Peak Power Output Value (dBm) = 10*LOG (Chain B1 (mW)+ Chain B2 (mW))

2.Limit = 30dBm – (Ant Gain-6) ; 30dBm – (13-6) = 23dBm

4. Radiated Emission

4.1. Test Setup

Radiated Emission Under 30MHz

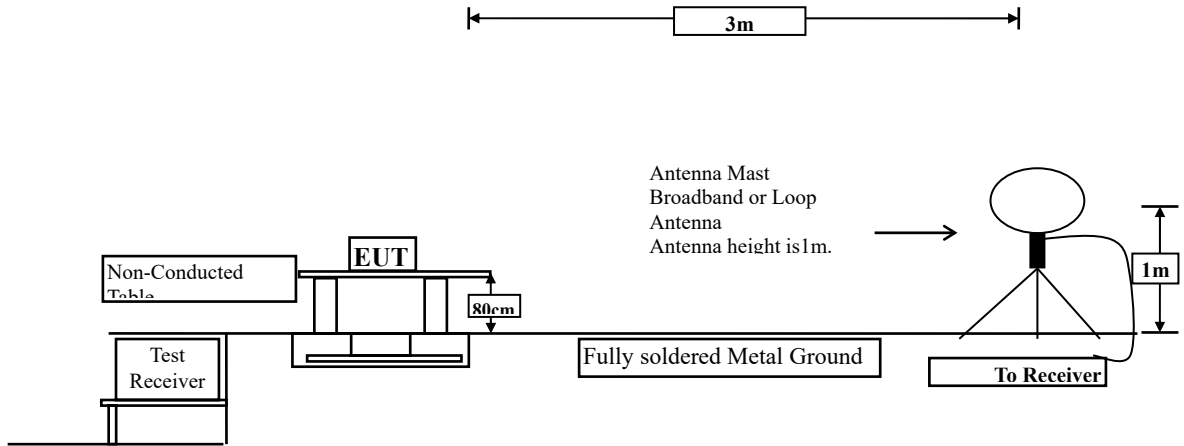

Radiated Emission Below 1GHz

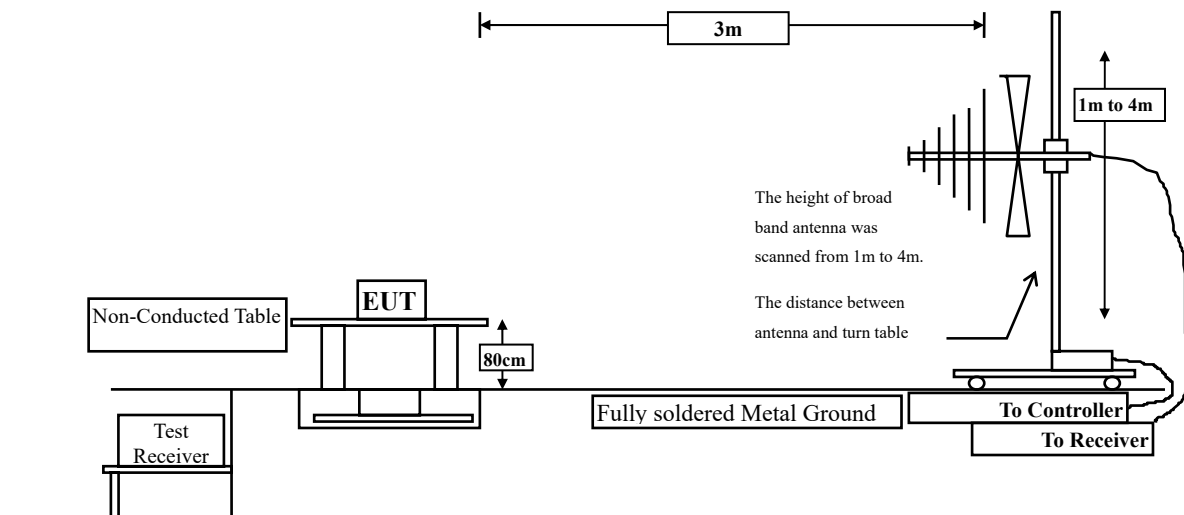

Radiated Emission Above 1GHz

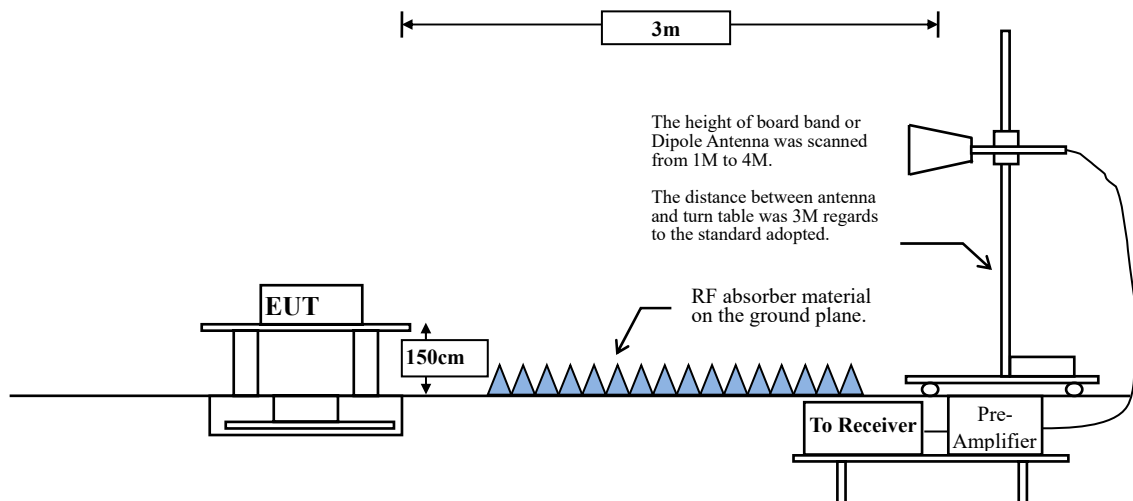

4.2. Limits

➤ General Radiated Emission Limits

Emissions radiated outside of the specified frequency bands, except for harmonics, shall be attenuated by at least 20dB below the level of the fundamental or to the general radiated emission limits in paragraph 15.209, whichever is the lesser attenuation.

FCC Part 15 Subpart C Paragraph 15.209 Limits		
Frequency MHz	Field strength (microvolts/meter)	Measurement distance (meter)
0.009-0.490	2400/F(kHz)	300
0.490-1.705	24000/F(kHz)	30
1.705-30	30	30
30-88	100	3
88-216	150	3
216-960	200	3
Above 960	500	3

- Remarks:
1. RF Voltage (dBuV) = 20 log RF Voltage (uV)
 2. In the Above Table, the tighter limit applies at the band edges.
 3. Distance refers to the distance in meters between the measuring instrument antenna and the closed point of any part of the device or system.

4.3. Test Procedure

The EUT was setup according to ANSI C63.10: 2013 and tested according to DTS test procedure of KDB558074 for compliance to FCC 47CFR 15.247 requirements.

Measuring the frequency range below 1GHz, the EUT is placed on a turn table which is 0.8 meter above ground, when measuring the frequency range above 1GHz, the EUT is placed on a turn table which is 1.5 meter above ground.

The turn table is rotated 360 degrees to determine the position of the maximum emission level.

The EUT was positioned such that the distance from antenna to the EUT was 3 meters.

The antenna is scanned between 1 meter and 4 meters to find out the maximum emission level. This is repeated for both horizontal and vertical polarization of the antenna. In order to find the maximum emission, all of the interface cables were manipulated according to ANSI C63.10: 2013 on radiated measurement.

The resolution bandwidth below 30MHz setting on the field strength meter is 9kHz and 30MHz~1GHz is 120kHz and above 1GHz is 1MHz.

Radiated emission measurements below 30MHz are made using Loop Antenna and 30MHz~1GHz are made using broadband Bilog antenna and above 1GHz are made using Horn Antennas.

The measurement is divided into the Preliminary Measurement and the Final Measurement.

The suspected frequencies are searched for in Preliminary Measurement with the measurement antenna kept pointed at the source of the emission both in azimuth and elevation, with the polarization of the antenna oriented for maximum response. The antenna is pointed at an angle towards the source of the emission, and the EUT is rotated in both height and polarization to maximize the measured emission. The emission is kept within the illumination area of the 3 dB bandwidth of the antenna.

The measurement frequency range from 9kHz - 10th Harmonic of fundamental was investigated.

RBW and VBW Parameter setting:

According to KDB 558074 Peak power measurement procedure

RBW = as specified in Table 1.

$VBW \geq 3 \times RBW$.

Table 1 —RBW as a function of frequency

Frequency	RBW
9-150 kHz	200-300 Hz
0.15-30 MHz	9-10 kHz
30-1000 MHz	100-120 kHz
> 1000 MHz	1 MHz

According to KDB 558074 Average power measurement procedure

RBW = 1MHz.

VBW = 10Hz, when duty cycle $\geq 98\%$

$VBW \geq 1/T$, when duty cycle $< 98\%$

(T refers to the minimum transmission duration over which the transmitter is on and is transmitting at its maximum power control level for the tested mode of operation.)

2.4GHz band	Duty Cycle (%)	T (ms)	1/T (Hz)	VBW (Hz)
A1, A2	100.00	311.5940	3	10
B1, B2	100.00	461.5940	2	10
A1, A2, B1, B2	100.00	479.7100	2	10

Note: Duty Cycle Refer to Section 9

4.4. Uncertainty

Horizontal polarization :

30-300MHz: ± 4.08 dB ; 300M-1GHz: ± 3.86 dB ; 1-18GHz: ± 3.77 dB ; 18-40GHz: ± 3.98 dB

Vertical polarization :

30-300MHz: ± 4.81 dB ; 300M-1GHz: ± 3.87 dB ; 1-18GHz: ± 3.83 dB ; 18-40GHz: ± 3.98 dB

4.5. Test Result of Radiated Emission

Product : Software defined radio
 Test Item : Harmonic Radiated Emission
 Test Mode : Mode 1: Transmit_Dipole (A1+ A2) (2412MHz)
 Test Date : 2018/02/24

Horizontal

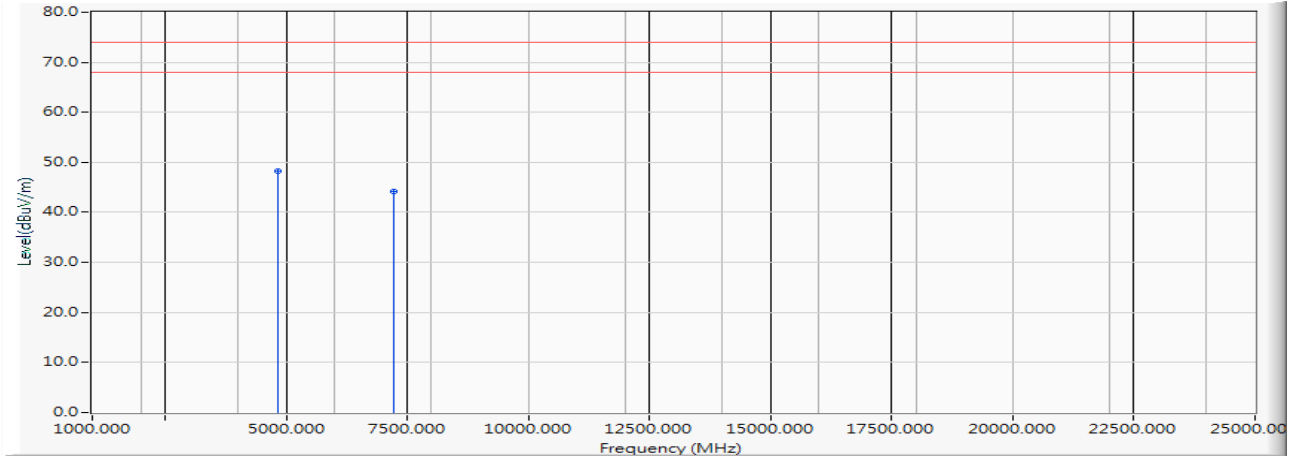

		Frequency (MHz)	Correct Factor (dB)	Reading Level (dBµV)	Measure Level (dBµV/m)	Margin (dB)	Limit (dBµV/m)	Detector Type
1	*	4824.000	-3.721	51.920	48.199	-25.801	74.000	PEAK
2		7236.000	0.206	44.040	44.247	-29.753	74.000	PEAK

Note:

1. All Readings below 1GHz are Quasi-Peak, above 1GHz are performed with peak and/or average measurements as necessary.
2. Measurement Level = Reading Level + Correct Factor.
3. Correct Factor = Antenna factor + Cable loss – Amplifier gain.
4. The average measurement was not performed when the peak measured data under the limit of average detection.
5. The emission levels of other frequencies are very lower than the limit and not show in test report.

Product : Software defined radio
 Test Item : Harmonic Radiated Emission
 Test Mode : Mode 1: Transmit_Dipole (A1+ A2) (2412MHz)
 Test Date : 2018/02/24

Vertical

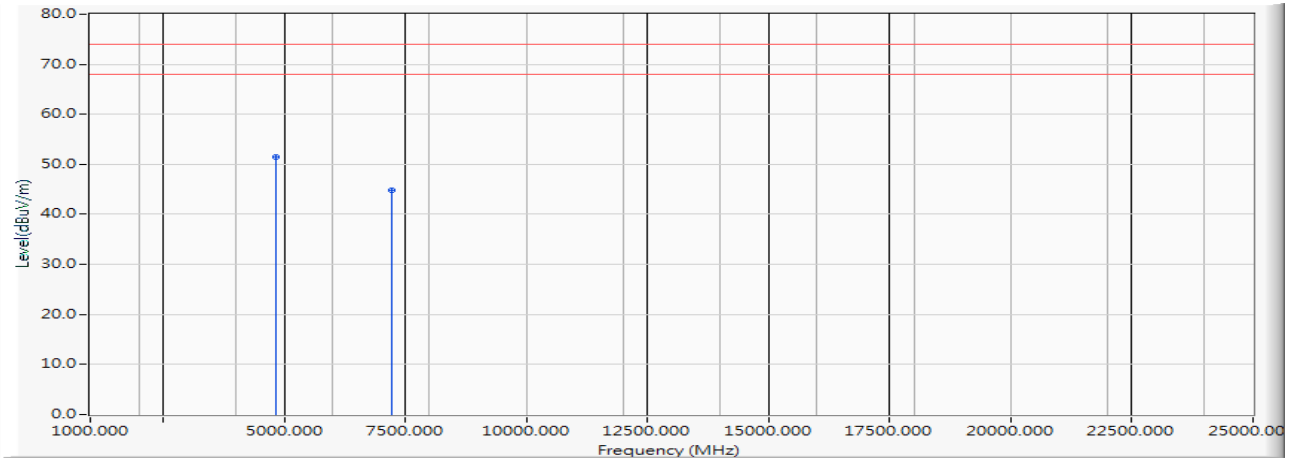

		Frequency (MHz)	Correct Factor (dB)	Reading Level (dBμV)	Measure Level (dBμV/m)	Margin (dB)	Limit (dBμV/m)	Detector Type
1	*	4824.000	-3.721	55.150	51.429	-22.571	74.000	PEAK
2		7236.000	0.206	44.590	44.797	-29.203	74.000	PEAK

Note:

1. All Readings below 1GHz are Quasi-Peak, above 1GHz are performed with peak and/or average measurements as necessary.
2. Measurement Level = Reading Level + Correct Factor.
3. Correct Factor = Antenna factor + Cable loss – Amplifier gain.
4. The average measurement was not performed when the peak measured data under the limit of average detection.
5. The emission levels of other frequencies are very lower than the limit and not show in test report.

Product : Software defined radio
 Test Item : Harmonic Radiated Emission
 Test Mode : Mode 1: Transmit_Dipole (A1+ A2) (2437MHz)
 Test Date : 2018/02/24

Horizontal

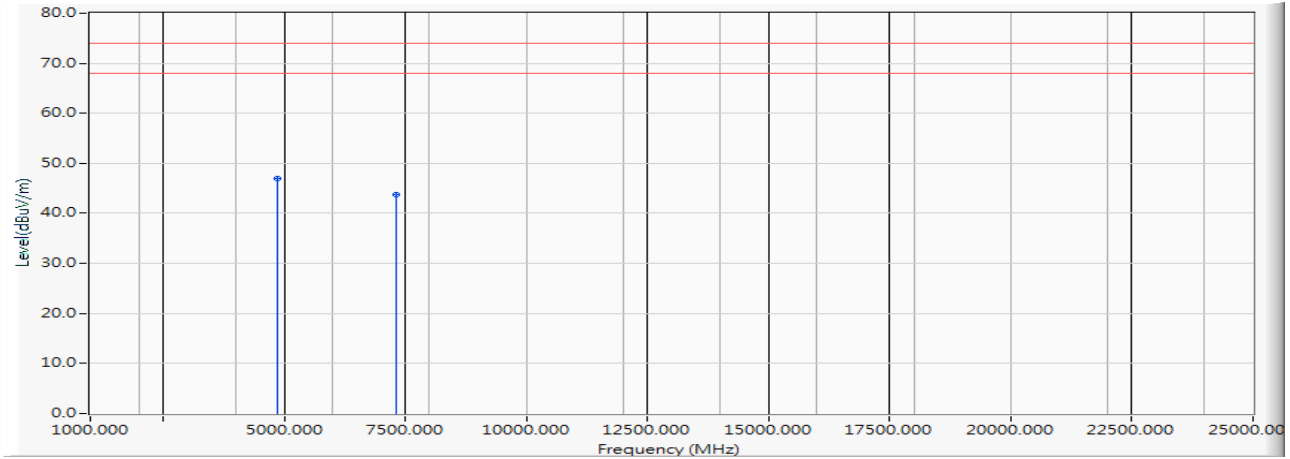

		Frequency (MHz)	Correct Factor (dB)	Reading Level (dBµV)	Measure Level (dBµV/m)	Margin (dB)	Limit (dBµV/m)	Detector Type
1	*	4874.000	-3.652	50.700	47.048	-26.952	74.000	PEAK
2		7311.000	0.239	43.580	43.819	-30.181	74.000	PEAK

Note:

1. All Readings below 1GHz are Quasi-Peak, above 1GHz are performed with peak and/or average measurements as necessary.
2. Measurement Level = Reading Level + Correct Factor.
3. Correct Factor = Antenna factor + Cable loss – Amplifier gain.
4. The average measurement was not performed when the peak measured data under the limit of average detection.
5. The emission levels of other frequencies are very lower than the limit and not show in test report.

Product : Software defined radio
 Test Item : Harmonic Radiated Emission
 Test Mode : Mode 1: Transmit_Dipole (A1+ A2) (2437MHz)
 Test Date : 2018/02/24

Vertical

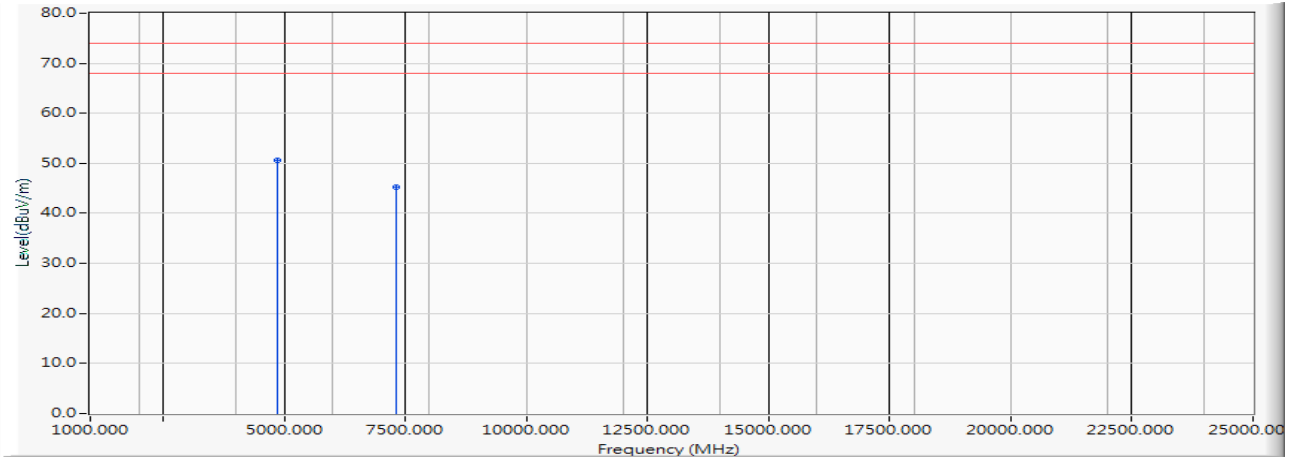

		Frequency (MHz)	Correct Factor (dB)	Reading Level (dBµV)	Measure Level (dBµV/m)	Margin (dB)	Limit (dBµV/m)	Detector Type
1	*	4874.000	-3.652	54.370	50.718	-23.282	74.000	PEAK
2		7311.000	0.239	44.990	45.229	-28.771	74.000	PEAK

Note:

1. All Readings below 1GHz are Quasi-Peak, above 1GHz are performed with peak and/or average measurements as necessary.
2. Measurement Level = Reading Level + Correct Factor.
3. Correct Factor = Antenna factor + Cable loss – Amplifier gain.
4. The average measurement was not performed when the peak measured data under the limit of average detection.
5. The emission levels of other frequencies are very lower than the limit and not show in test report.

Product : Software defined radio
 Test Item : Harmonic Radiated Emission
 Test Mode : Mode 1: Transmit_Dipole (A1+ A2) (2462MHz)
 Test Date : 2018/02/24

Horizontal

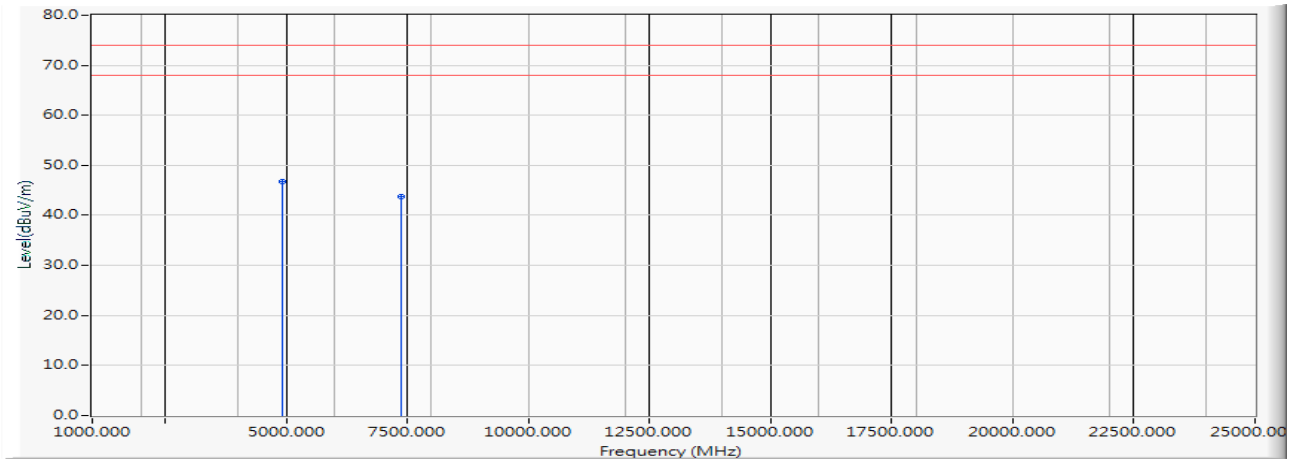

		Frequency (MHz)	Correct Factor (dB)	Reading Level (dBµV)	Measure Level (dBµV/m)	Margin (dB)	Limit (dBµV/m)	Detector Type
1	*	4924.000	-3.622	50.400	46.779	-27.221	74.000	PEAK
2		7386.000	0.309	43.410	43.719	-30.281	74.000	PEAK

Note:

1. All Readings below 1GHz are Quasi-Peak, above 1GHz are performed with peak and/or average measurements as necessary.
2. Measurement Level = Reading Level + Correct Factor.
3. Correct Factor = Antenna factor + Cable loss – Amplifier gain.
4. The average measurement was not performed when the peak measured data under the limit of average detection.
5. The emission levels of other frequencies are very lower than the limit and not show in test report.

Product : Software defined radio
 Test Item : Harmonic Radiated Emission
 Test Mode : Mode 1: Transmit_Dipole (A1+ A2) (2462MHz)
 Test Date : 2018/02/24

Vertical

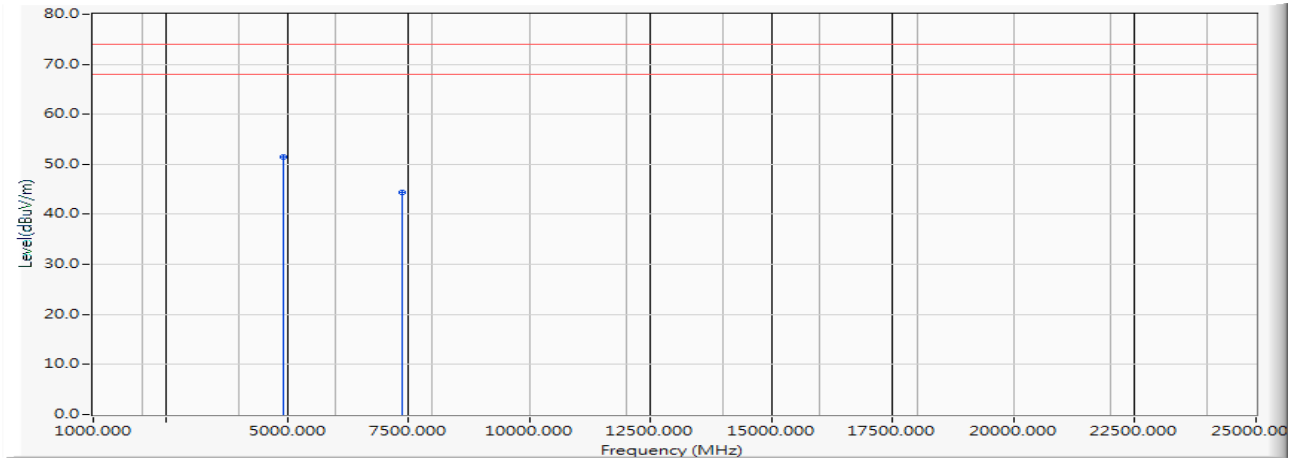

		Frequency (MHz)	Correct Factor (dB)	Reading Level (dBµV)	Measure Level (dBµV/m)	Margin (dB)	Limit (dBµV/m)	Detector Type
1	*	4924.000	-3.622	55.120	51.499	-22.501	74.000	PEAK
2		7386.000	0.309	44.050	44.359	-29.641	74.000	PEAK

Note:

1. All Readings below 1GHz are Quasi-Peak, above 1GHz are performed with peak and/or average measurements as necessary.
2. Measurement Level = Reading Level + Correct Factor.
3. Correct Factor = Antenna factor + Cable loss – Amplifier gain.
4. The average measurement was not performed when the peak measured data under the limit of average detection.
5. The emission levels of other frequencies are very lower than the limit and not show in test report.

Product : Software defined radio
 Test Item : Harmonic Radiated Emission
 Test Mode : Mode 1: Transmit_Dipole (A1+ A2+ B1+ B2) (2412MHz)
 Test Date : 2018/02/24

Horizontal

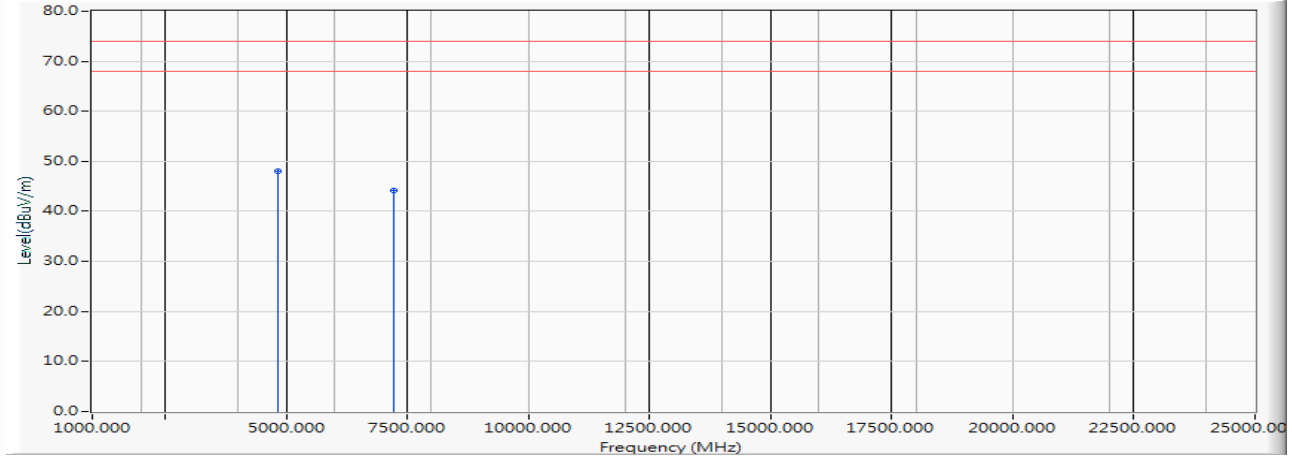

		Frequency (MHz)	Correct Factor (dB)	Reading Level (dBμV)	Measure Level (dBμV/m)	Margin (dB)	Limit (dBμV/m)	Detector Type
1	*	4824.000	-3.721	51.690	47.969	-26.031	74.000	PEAK
2		7236.000	0.206	44.050	44.257	-29.743	74.000	PEAK

Note:

1. All Readings below 1GHz are Quasi-Peak, above 1GHz are performed with peak and/or average measurements as necessary.
2. Measurement Level = Reading Level + Correct Factor.
3. Correct Factor = Antenna factor + Cable loss – Amplifier gain.
4. The average measurement was not performed when the peak measured data under the limit of average detection.
5. The emission levels of other frequencies are very lower than the limit and not show in test report.

Product : Software defined radio
 Test Item : Harmonic Radiated Emission
 Test Mode : Mode 1: Transmit_Dipole (A1+ A2+ B1+ B2) (2412MHz)
 Test Date : 2018/02/24

Vertical

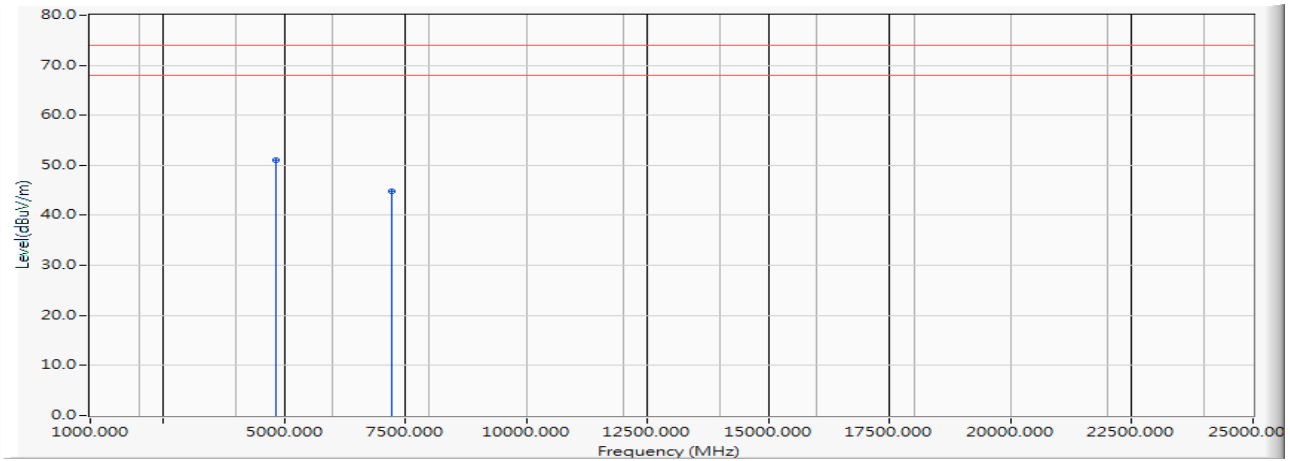

		Frequency (MHz)	Correct Factor (dB)	Reading Level (dBµV)	Measure Level (dBµV/m)	Margin (dB)	Limit (dBµV/m)	Detector Type
1	*	4824.000	-3.721	54.870	51.149	-22.851	74.000	PEAK
2		7236.000	0.206	44.520	44.727	-29.273	74.000	PEAK

Note:

1. All Readings below 1GHz are Quasi-Peak, above 1GHz are performed with peak and/or average measurements as necessary.
2. Measurement Level = Reading Level + Correct Factor.
3. Correct Factor = Antenna factor + Cable loss – Amplifier gain.
4. The average measurement was not performed when the peak measured data under the limit of average detection.
5. The emission levels of other frequencies are very lower than the limit and not show in test report.

Product : Software defined radio
 Test Item : Harmonic Radiated Emission
 Test Mode : Mode 1: Transmit_Dipole (A1+ A2+ B1+ B2) (2437MHz)
 Test Date : 2018/02/24

Horizontal

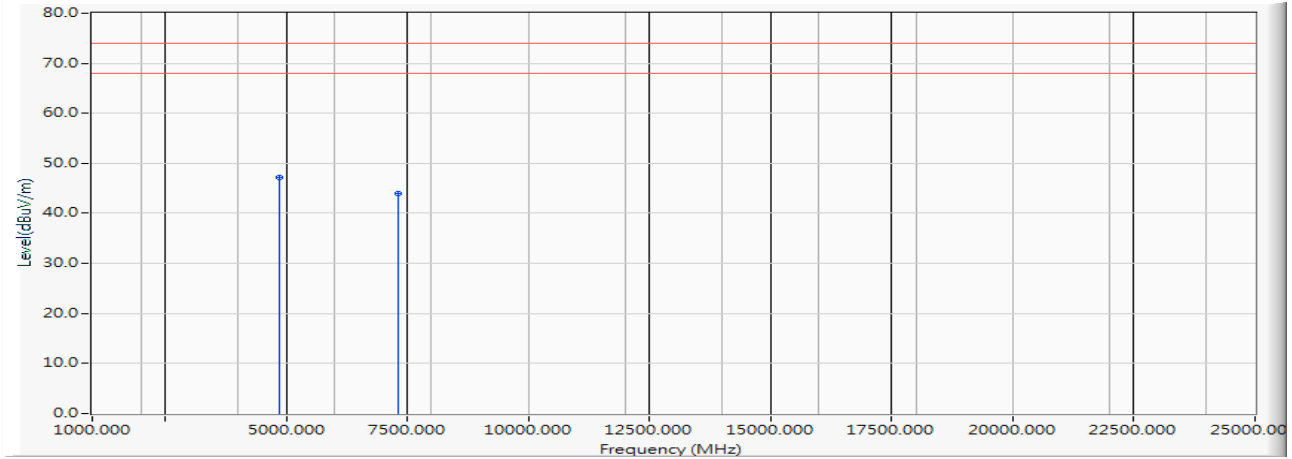

		Frequency (MHz)	Correct Factor (dB)	Reading Level (dBµV)	Measure Level (dBµV/m)	Margin (dB)	Limit (dBµV/m)	Detector Type
1	*	4874.000	-3.652	50.840	47.188	-26.812	74.000	PEAK
2		7311.000	0.239	43.780	44.019	-29.981	74.000	PEAK

Note:

1. All Readings below 1GHz are Quasi-Peak, above 1GHz are performed with peak and/or average measurements as necessary.
2. Measurement Level = Reading Level + Correct Factor.
3. Correct Factor = Antenna factor + Cable loss –Amplifier gain.
4. The average measurement was not performed when the peak measured data under the limit of average detection.
5. The emission levels of other frequencies are very lower than the limit and not show in test report.

Product : Software defined radio
 Test Item : Harmonic Radiated Emission
 Test Mode : Mode 1: Transmit_Dipole (A1+ A2+ B1+ B2) (2437MHz)
 Test Date : 2018/02/24

Vertical

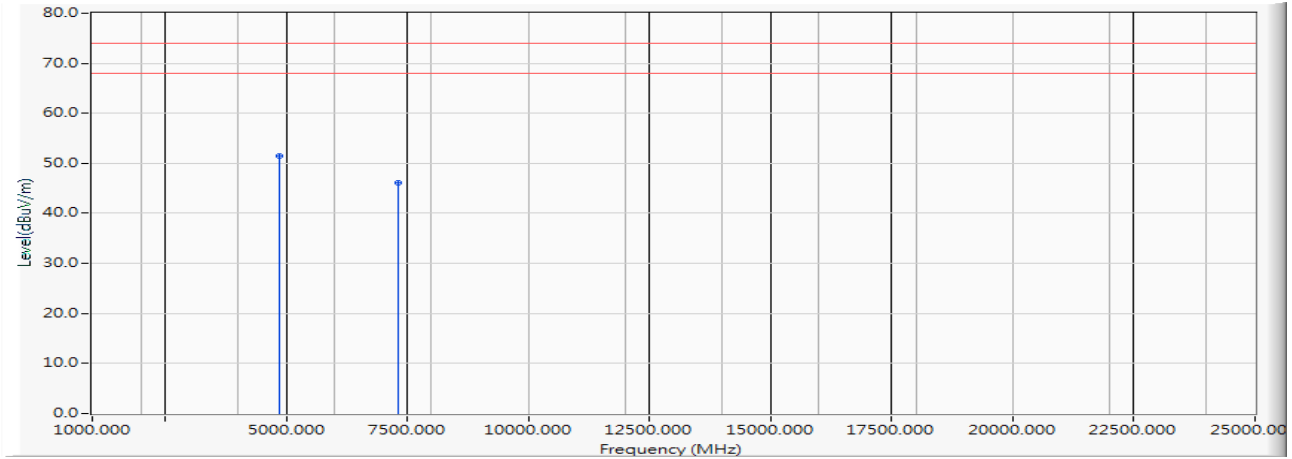

		Frequency (MHz)	Correct Factor (dB)	Reading Level (dBμV)	Measure Level (dBμV/m)	Margin (dB)	Limit (dBμV/m)	Detector Type
1	*	4874.000	-3.652	55.030	51.378	-22.622	74.000	PEAK
2		7311.000	0.239	45.980	46.219	-27.781	74.000	PEAK

Note:

1. All Readings below 1GHz are Quasi-Peak, above 1GHz are performed with peak and/or average measurements as necessary.
2. Measurement Level = Reading Level + Correct Factor.
3. Correct Factor = Antenna factor + Cable loss – Amplifier gain.
4. The average measurement was not performed when the peak measured data under the limit of average detection.
5. The emission levels of other frequencies are very lower than the limit and not show in test report.

Product : Software defined radio
 Test Item : Harmonic Radiated Emission
 Test Mode : Mode 1: Transmit_Dipole (A1+ A2+ B1+ B2) (2462MHz)
 Test Date : 2018/02/24

Horizontal

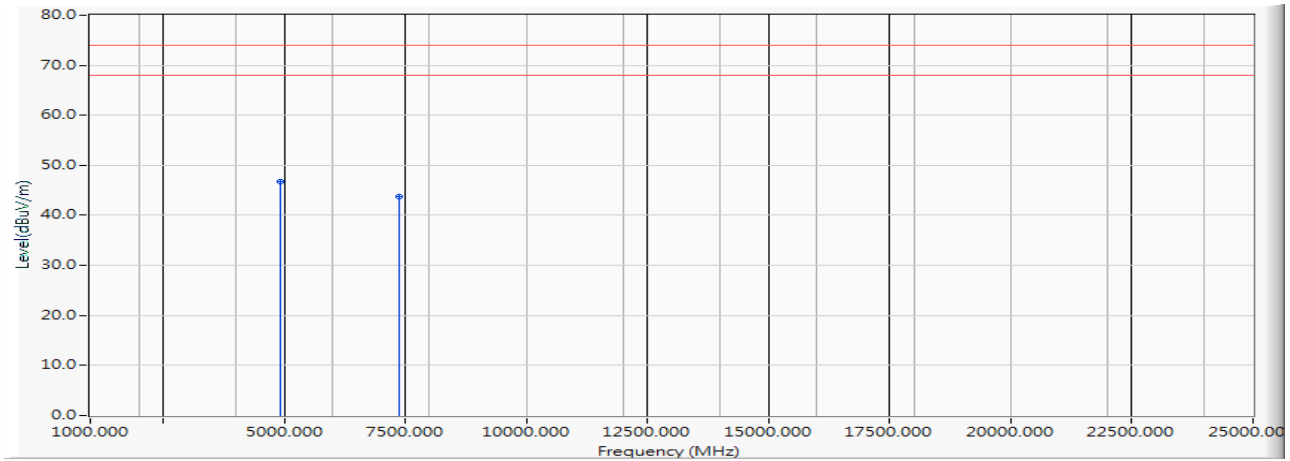

		Frequency (MHz)	Correct Factor (dB)	Reading Level (dBµV)	Measure Level (dBµV/m)	Margin (dB)	Limit (dBµV/m)	Detector Type
1	*	4924.000	-3.622	50.480	46.859	-27.141	74.000	PEAK
2		7386.000	0.309	43.450	43.759	-30.241	74.000	PEAK

Note:

1. All Readings below 1GHz are Quasi-Peak, above 1GHz are performed with peak and/or average measurements as necessary.
2. Measurement Level = Reading Level + Correct Factor.
3. Correct Factor = Antenna factor + Cable loss – Amplifier gain.
4. The average measurement was not performed when the peak measured data under the limit of average detection.
5. The emission levels of other frequencies are very lower than the limit and not show in test report.

Product : Software defined radio
 Test Item : Harmonic Radiated Emission
 Test Mode : Mode 1: Transmit_Dipole (A1+ A2+ B1+ B2) (2462MHz)
 Test Date : 2018/02/24

Vertical

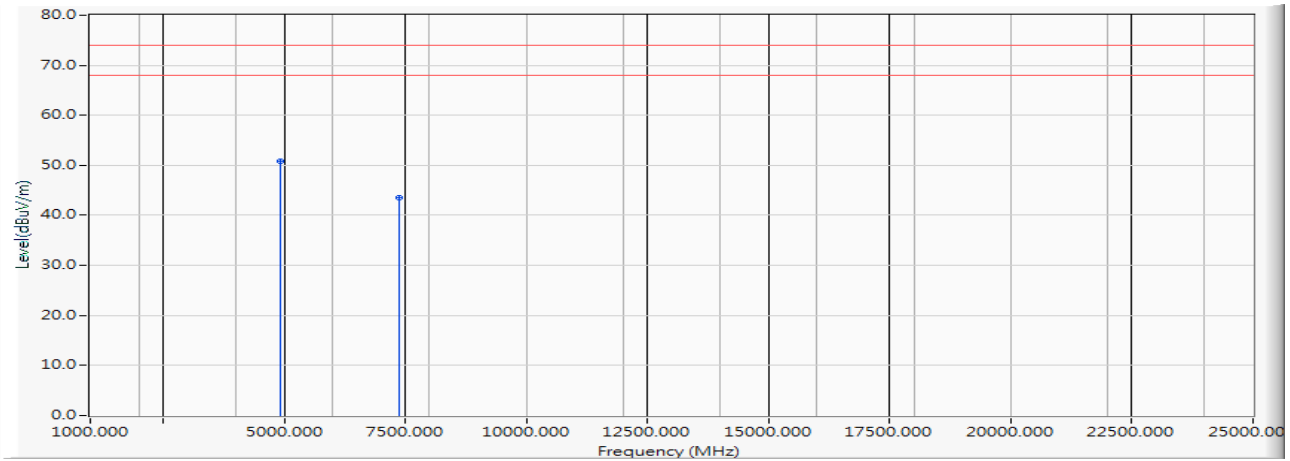

		Frequency (MHz)	Correct Factor (dB)	Reading Level (dBµV)	Measure Level (dBµV/m)	Margin (dB)	Limit (dBµV/m)	Detector Type
1	*	4924.000	-3.622	54.360	50.739	-23.261	74.000	PEAK
2		7386.000	0.309	43.320	43.629	-30.371	74.000	PEAK

Note:

1. All Readings below 1GHz are Quasi-Peak, above 1GHz are performed with peak and/or average measurements as necessary.
2. Measurement Level = Reading Level + Correct Factor.
3. Correct Factor = Antenna factor + Cable loss – Amplifier gain.
4. The average measurement was not performed when the peak measured data under the limit of average detection.
5. The emission levels of other frequencies are very lower than the limit and not show in test report.

Product : Software defined radio
 Test Item : Harmonic Radiated Emission
 Test Mode : Mode 1: Transmit_Dipole (B1+ B2) (2412MHz)
 Test Date : 2018/02/24

Horizontal

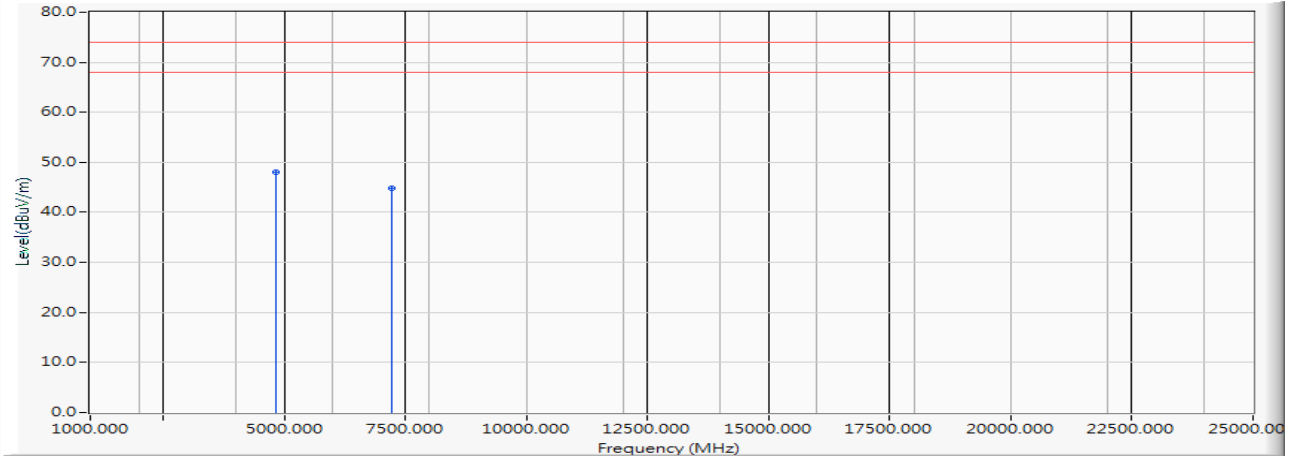

		Frequency (MHz)	Correct Factor (dB)	Reading Level (dBµV)	Measure Level (dBµV/m)	Margin (dB)	Limit (dBµV/m)	Detector Type
1	*	4824.000	-3.721	51.680	47.959	-26.041	74.000	PEAK
2		7236.000	0.206	44.610	44.817	-29.183	74.000	PEAK

Note:

1. All Readings below 1GHz are Quasi-Peak, above 1GHz are performed with peak and/or average measurements as necessary.
2. Measurement Level = Reading Level + Correct Factor.
3. Correct Factor = Antenna factor + Cable loss – Amplifier gain.
4. The average measurement was not performed when the peak measured data under the limit of average detection.
5. The emission levels of other frequencies are very lower than the limit and not show in test report.

Product : Software defined radio
 Test Item : Harmonic Radiated Emission
 Test Mode : Mode 1: Transmit_Dipole (B1+ B2) (2412MHz)
 Test Date : 2018/02/24

Vertical

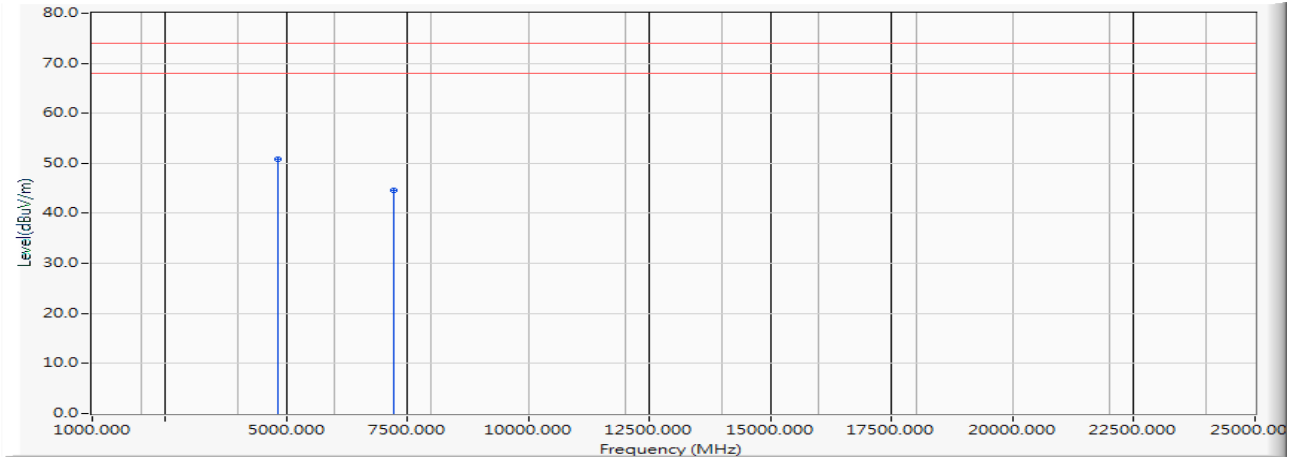

		Frequency (MHz)	Correct Factor (dB)	Reading Level (dBμV)	Measure Level (dBμV/m)	Margin (dB)	Limit (dBμV/m)	Detector Type
1	*	4824.000	-3.721	54.600	50.879	-23.121	74.000	PEAK
2		7236.000	0.206	44.460	44.667	-29.333	74.000	PEAK

Note:

1. All Readings below 1GHz are Quasi-Peak, above 1GHz are performed with peak and/or average measurements as necessary.
2. Measurement Level = Reading Level + Correct Factor.
3. Correct Factor = Antenna factor + Cable loss – Amplifier gain.
4. The average measurement was not performed when the peak measured data under the limit of average detection.
5. The emission levels of other frequencies are very lower than the limit and not show in test report.

Product : Software defined radio
 Test Item : Harmonic Radiated Emission
 Test Mode : Mode 1: Transmit_Dipole (B1+ B2) (2437MHz)
 Test Date : 2018/02/24

Horizontal

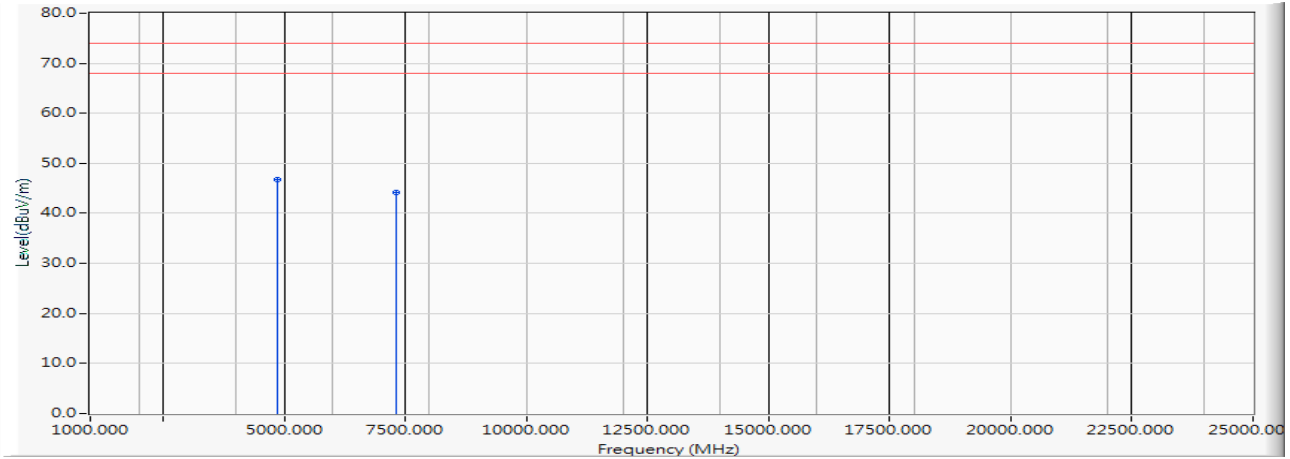

		Frequency (MHz)	Correct Factor (dB)	Reading Level (dBµV)	Measure Level (dBµV/m)	Margin (dB)	Limit (dBµV/m)	Detector Type
1	*	4874.000	-3.652	50.480	46.828	-27.172	74.000	PEAK
2		7311.000	0.239	44.020	44.259	-29.741	74.000	PEAK

Note:

1. All Readings below 1GHz are Quasi-Peak, above 1GHz are performed with peak and/or average measurements as necessary.
2. Measurement Level = Reading Level + Correct Factor.
3. Correct Factor = Antenna factor + Cable loss – Amplifier gain.
4. The average measurement was not performed when the peak measured data under the limit of average detection.
5. The emission levels of other frequencies are very lower than the limit and not show in test report.

Product : Software defined radio
 Test Item : Harmonic Radiated Emission
 Test Mode : Mode 1: Transmit_Dipole (B1+ B2) (2437MHz)
 Test Date : 2018/02/24

Vertical

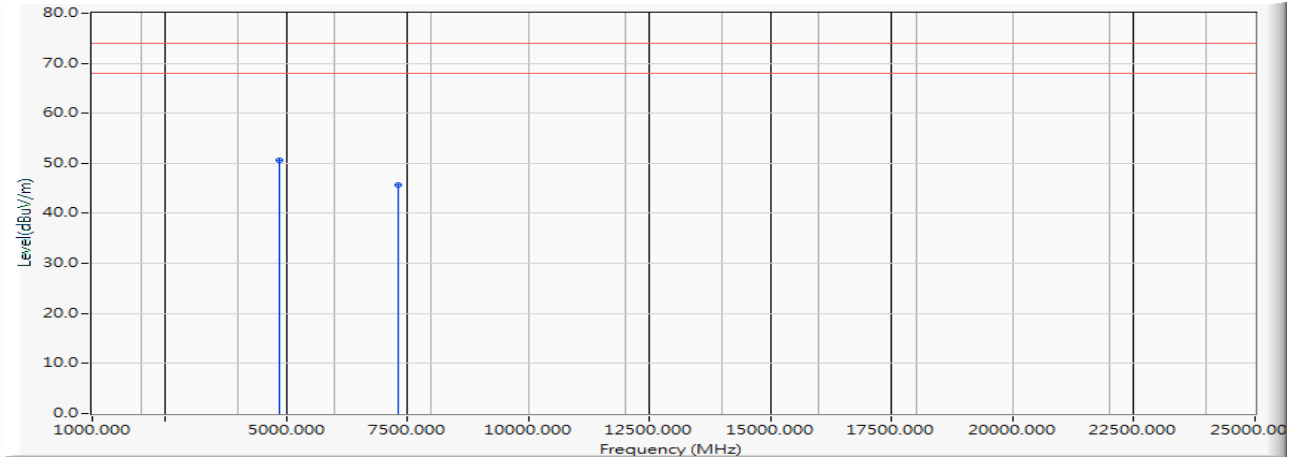

		Frequency (MHz)	Correct Factor (dB)	Reading Level (dBμV)	Measure Level (dBμV/m)	Margin (dB)	Limit (dBμV/m)	Detector Type
1	*	4874.000	-3.652	54.320	50.668	-23.332	74.000	PEAK
2		7311.000	0.239	45.400	45.639	-28.361	74.000	PEAK

Note:

1. All Readings below 1GHz are Quasi-Peak, above 1GHz are performed with peak and/or average measurements as necessary.
2. Measurement Level = Reading Level + Correct Factor.
3. Correct Factor = Antenna factor + Cable loss – Amplifier gain.
4. The average measurement was not performed when the peak measured data under the limit of average detection.
5. The emission levels of other frequencies are very lower than the limit and not show in test report.

Product : Software defined radio
 Test Item : Harmonic Radiated Emission
 Test Mode : Mode 1: Transmit_Dipole (B1+ B2) (2462MHz)
 Test Date : 2018/02/24

Horizontal

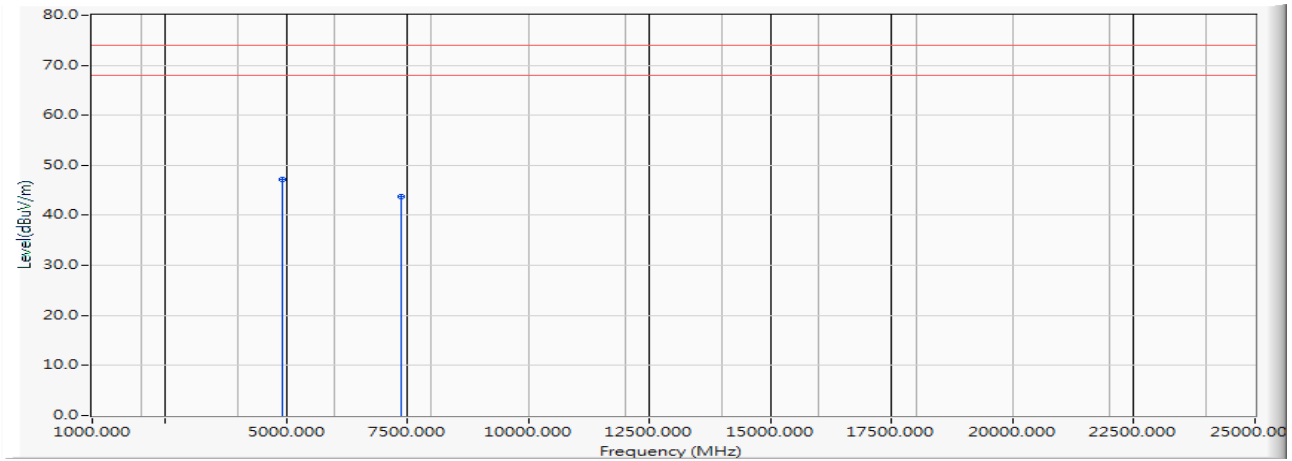

		Frequency (MHz)	Correct Factor (dB)	Reading Level (dBµV)	Measure Level (dBµV/m)	Margin (dB)	Limit (dBµV/m)	Detector Type
1	*	4924.000	-3.622	50.770	47.149	-26.851	74.000	PEAK
2		7386.000	0.309	43.520	43.829	-30.171	74.000	PEAK

Note:

1. All Readings below 1GHz are Quasi-Peak, above 1GHz are performed with peak and/or average measurements as necessary.
2. Measurement Level = Reading Level + Correct Factor.
3. Correct Factor = Antenna factor + Cable loss – Amplifier gain.
4. The average measurement was not performed when the peak measured data under the limit of average detection.
5. The emission levels of other frequencies are very lower than the limit and not show in test report.

Product : Software defined radio
 Test Item : Harmonic Radiated Emission
 Test Mode : Mode 1: Transmit_Dipole (B1+ B2) (2462MHz)
 Test Date : 2018/02/24

Vertical

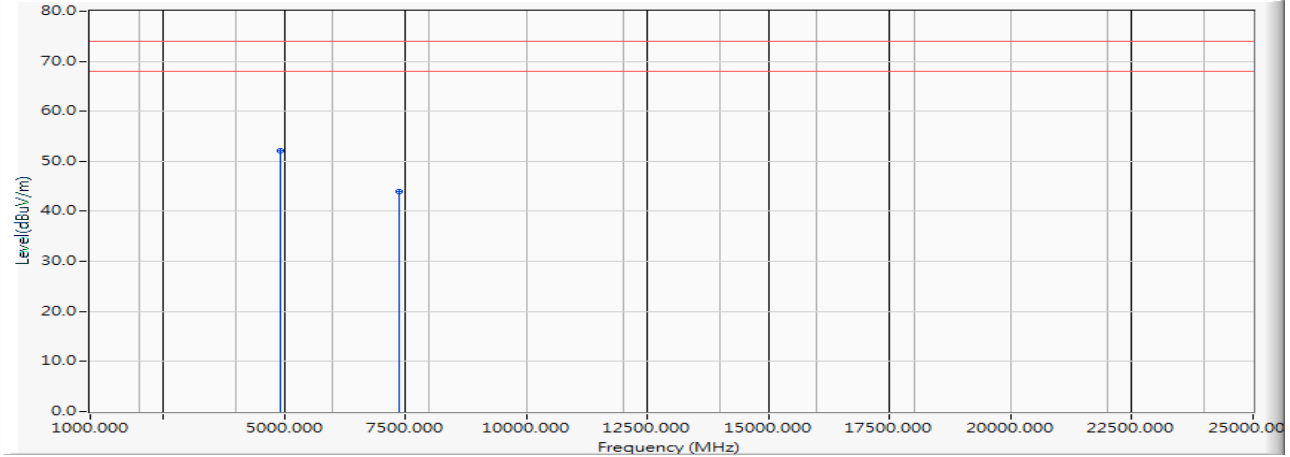

		Frequency (MHz)	Correct Factor (dB)	Reading Level (dBµV)	Measure Level (dBµV/m)	Margin (dB)	Limit (dBµV/m)	Detector Type
1	*	4924.000	-3.622	55.650	52.029	-21.971	74.000	PEAK
2		7386.000	0.309	43.570	43.879	-30.121	74.000	PEAK

Note:

1. All Readings below 1GHz are Quasi-Peak, above 1GHz are performed with peak and/or average measurements as necessary.
2. Measurement Level = Reading Level + Correct Factor.
3. Correct Factor = Antenna factor + Cable loss – Amplifier gain.
4. The average measurement was not performed when the peak measured data under the limit of average detection.
5. The emission levels of other frequencies are very lower than the limit and not show in test report.

Product : Software defined radio
 Test Item : Harmonic Radiated Emission
 Test Mode : Mode 2: Transmit_Patch (A1+ A2) (2412MHz)
 Test Date : 2018/02/22

Horizontal

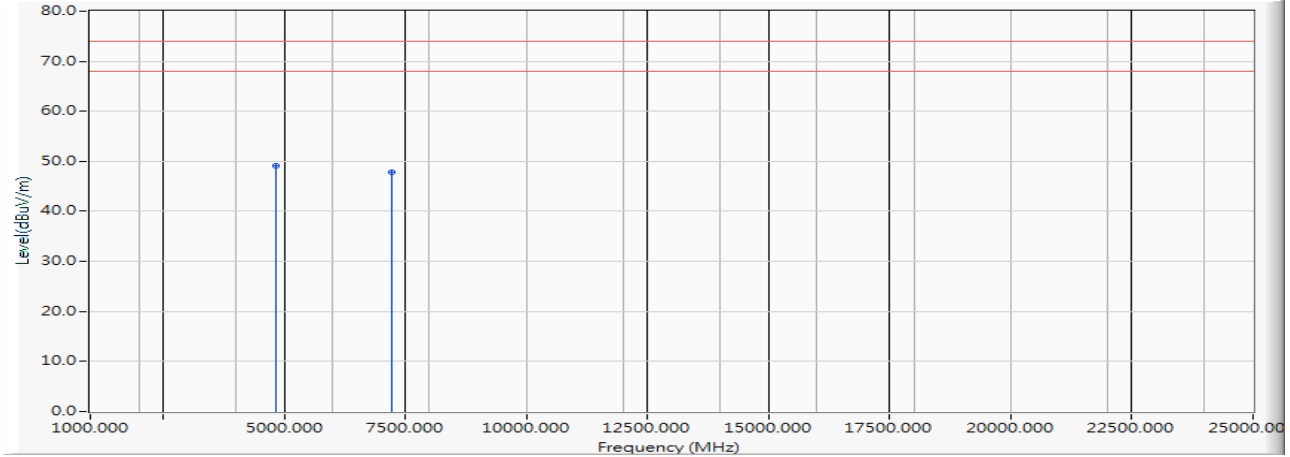

		Frequency (MHz)	Correct Factor (dB)	Reading Level (dBµV)	Measure Level (dBµV/m)	Margin (dB)	Limit (dBµV/m)	Detector Type
1	*	4824.000	-2.547	51.660	49.113	-24.887	74.000	PEAK
2		7236.000	0.811	46.940	47.751	-26.249	74.000	PEAK

Note:

1. All Readings below 1GHz are Quasi-Peak, above 1GHz are performed with peak and/or average measurements as necessary.
2. Measurement Level = Reading Level + Correct Factor.
3. Correct Factor = Antenna factor + Cable loss – Amplifier gain.
4. The average measurement was not performed when the peak measured data under the limit of average detection.
5. The emission levels of other frequencies are very lower than the limit and not show in test report.

Product : Software defined radio
 Test Item : Harmonic Radiated Emission
 Test Mode : Mode 2: Transmit_Patch (A1+ A2) (2412MHz)
 Test Date : 2018/02/22

Vertical

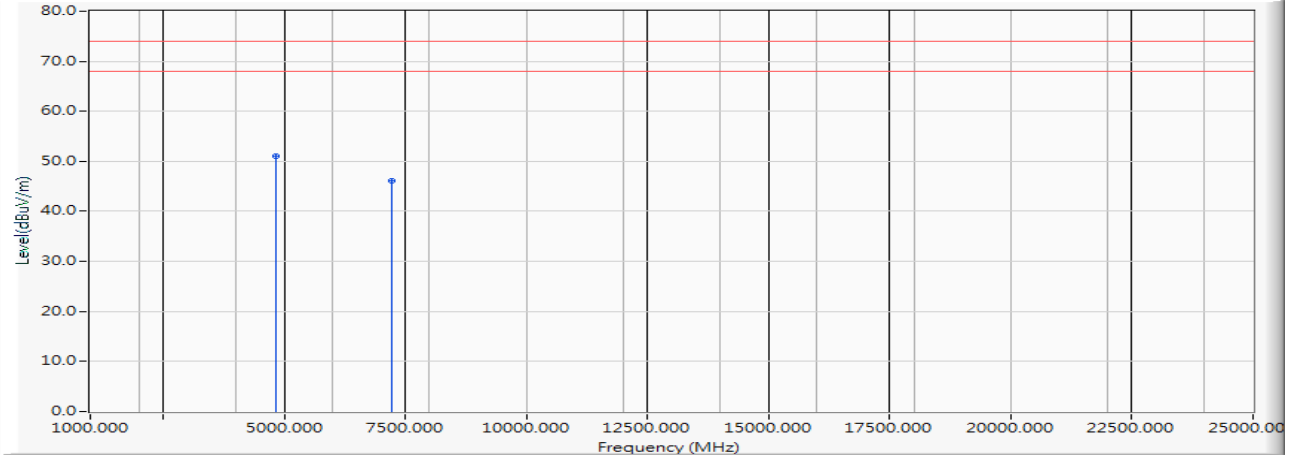

		Frequency (MHz)	Correct Factor (dB)	Reading Level (dBµV)	Measure Level (dBµV/m)	Margin (dB)	Limit (dBµV/m)	Detector Type
1	*	4824.000	-2.547	53.550	51.003	-22.997	74.000	PEAK
2		7236.000	0.811	45.400	46.211	-27.789	74.000	PEAK

Note:

1. All Readings below 1GHz are Quasi-Peak, above 1GHz are performed with peak and/or average measurements as necessary.
2. Measurement Level = Reading Level + Correct Factor.
3. Correct Factor = Antenna factor + Cable loss –Amplifier gain.
4. The average measurement was not performed when the peak measured data under the limit of average detection.
5. The emission levels of other frequencies are very lower than the limit and not show in test report.

Product : Software defined radio
 Test Item : Harmonic Radiated Emission
 Test Mode : Mode 2: Transmit_Patch (A1+ A2) (2437MHz)
 Test Date : 2018/02/22

Horizontal

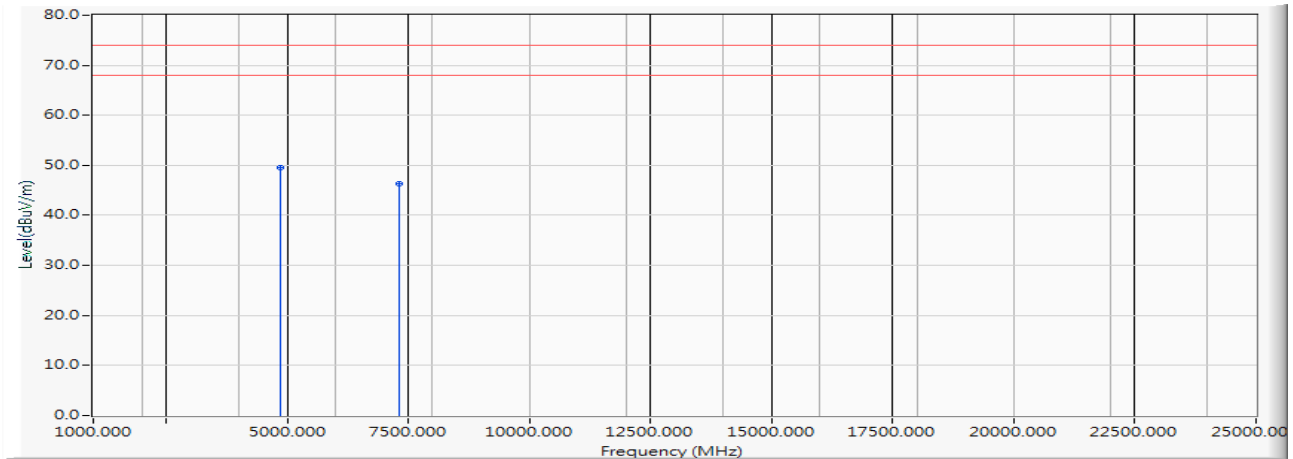

		Frequency (MHz)	Correct Factor (dB)	Reading Level (dBμV)	Measure Level (dBμV/m)	Margin (dB)	Limit (dBμV/m)	Detector Type
1	*	4874.000	-2.393	51.940	49.546	-24.454	74.000	PEAK
2		7311.000	0.810	45.450	46.260	-27.740	74.000	PEAK

Note:

1. All Readings below 1GHz are Quasi-Peak, above 1GHz are performed with peak and/or average measurements as necessary.
2. Measurement Level = Reading Level + Correct Factor.
3. Correct Factor = Antenna factor + Cable loss – Amplifier gain.
4. The average measurement was not performed when the peak measured data under the limit of average detection.
5. The emission levels of other frequencies are very lower than the limit and not show in test report.

Product : Software defined radio
 Test Item : Harmonic Radiated Emission
 Test Mode : Mode 2: Transmit_Patch (A1+ A2) (2437MHz)
 Test Date : 2018/02/22

Vertical

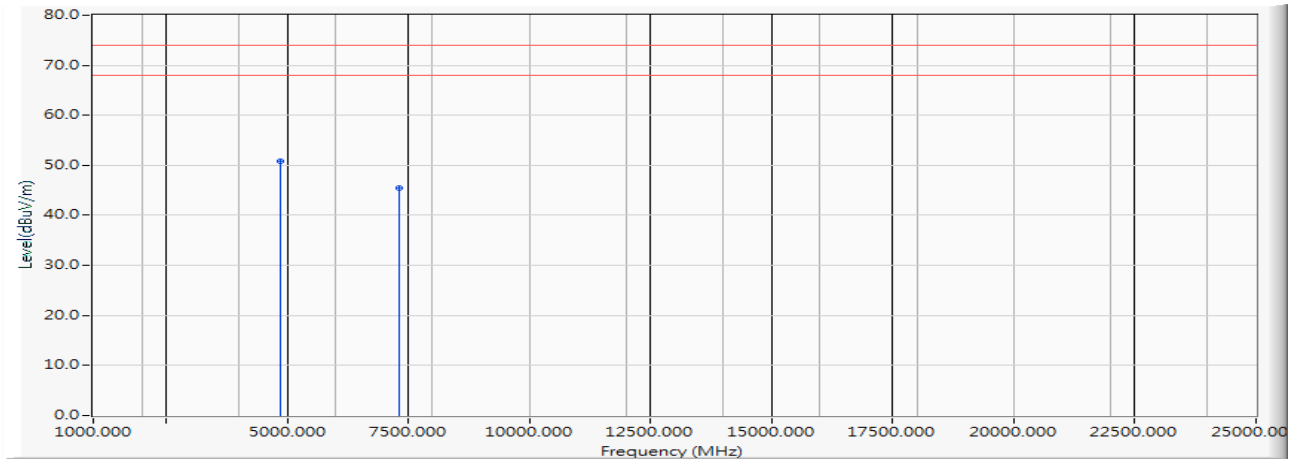

		Frequency (MHz)	Correct Factor (dB)	Reading Level (dBμV)	Measure Level (dBμV/m)	Margin (dB)	Limit (dBμV/m)	Detector Type
1	*	4874.000	-2.393	53.270	50.876	-23.124	74.000	PEAK
2		7311.000	0.810	44.580	45.390	-28.610	74.000	PEAK

Note:

1. All Readings below 1GHz are Quasi-Peak, above 1GHz are performed with peak and/or average measurements as necessary.
2. Measurement Level = Reading Level + Correct Factor.
3. Correct Factor = Antenna factor + Cable loss – Amplifier gain.
4. The average measurement was not performed when the peak measured data under the limit of average detection.
5. The emission levels of other frequencies are very lower than the limit and not show in test report.

Product : Software defined radio
 Test Item : Harmonic Radiated Emission
 Test Mode : Mode 2: Transmit_Patch (A1+ A2) (2462MHz)
 Test Date : 2018/02/22

Horizontal

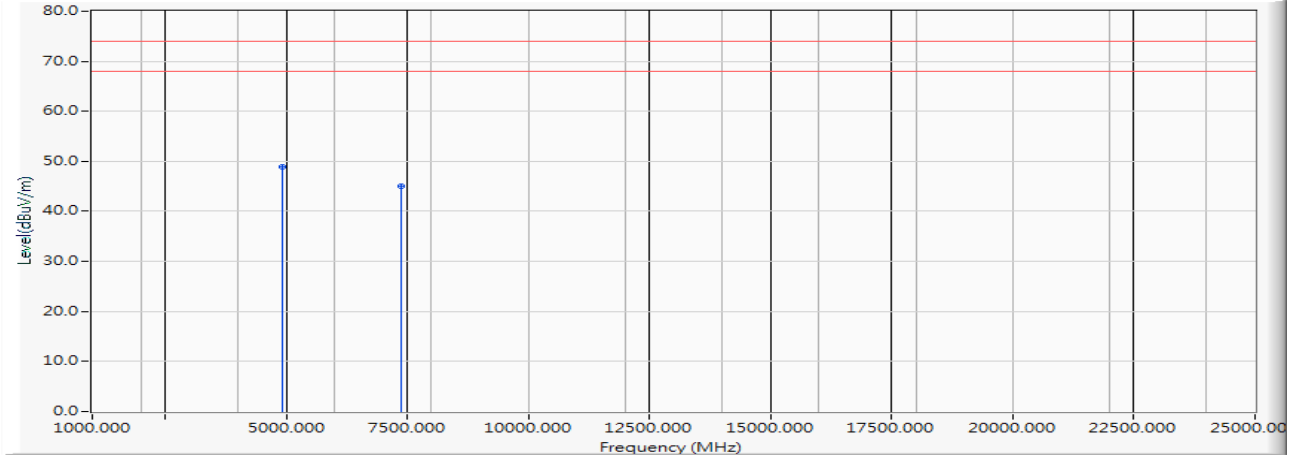

		Frequency (MHz)	Correct Factor (dB)	Reading Level (dBµV)	Measure Level (dBµV/m)	Margin (dB)	Limit (dBµV/m)	Detector Type
1	*	4924.000	-2.402	51.340	48.938	-25.062	74.000	PEAK
2		7386.000	0.806	44.140	44.946	-29.054	74.000	PEAK

Note:

1. All Readings below 1GHz are Quasi-Peak, above 1GHz are performed with peak and/or average measurements as necessary.
2. Measurement Level = Reading Level + Correct Factor.
3. Correct Factor = Antenna factor + Cable loss – Amplifier gain.
4. The average measurement was not performed when the peak measured data under the limit of average detection.
5. The emission levels of other frequencies are very lower than the limit and not show in test report.

Product : Software defined radio
 Test Item : Harmonic Radiated Emission
 Test Mode : Mode 2: Transmit_Patch (A1+ A2) (2462MHz)
 Test Date : 2018/02/22

Vertical

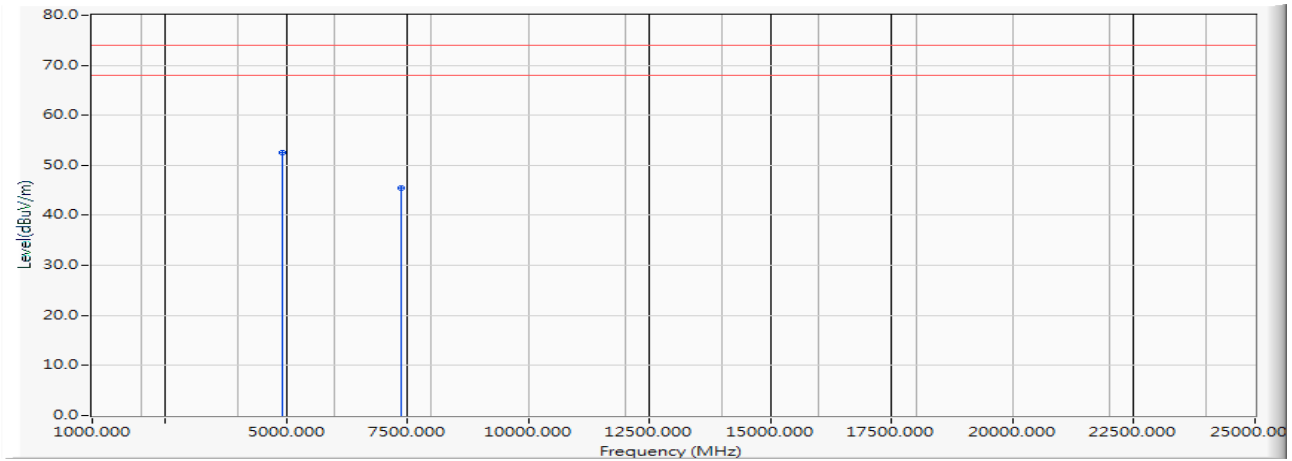

		Frequency (MHz)	Correct Factor (dB)	Reading Level (dBμV)	Measure Level (dBμV/m)	Margin (dB)	Limit (dBμV/m)	Detector Type
1	*	4924.000	-2.402	54.970	52.568	-21.432	74.000	PEAK
2		7386.000	0.806	44.660	45.466	-28.534	74.000	PEAK

Note:

1. All Readings below 1GHz are Quasi-Peak, above 1GHz are performed with peak and/or average measurements as necessary.
2. Measurement Level = Reading Level + Correct Factor.
3. Correct Factor = Antenna factor + Cable loss – Amplifier gain.
4. The average measurement was not performed when the peak measured data under the limit of average detection.
5. The emission levels of other frequencies are very lower than the limit and not show in test report.

Product : Software defined radio
 Test Item : Harmonic Radiated Emission
 Test Mode : Mode 2: Transmit_Patch (A1+ A2+ B1+ B2) (2412MHz)
 Test Date : 2018/02/22

Horizontal

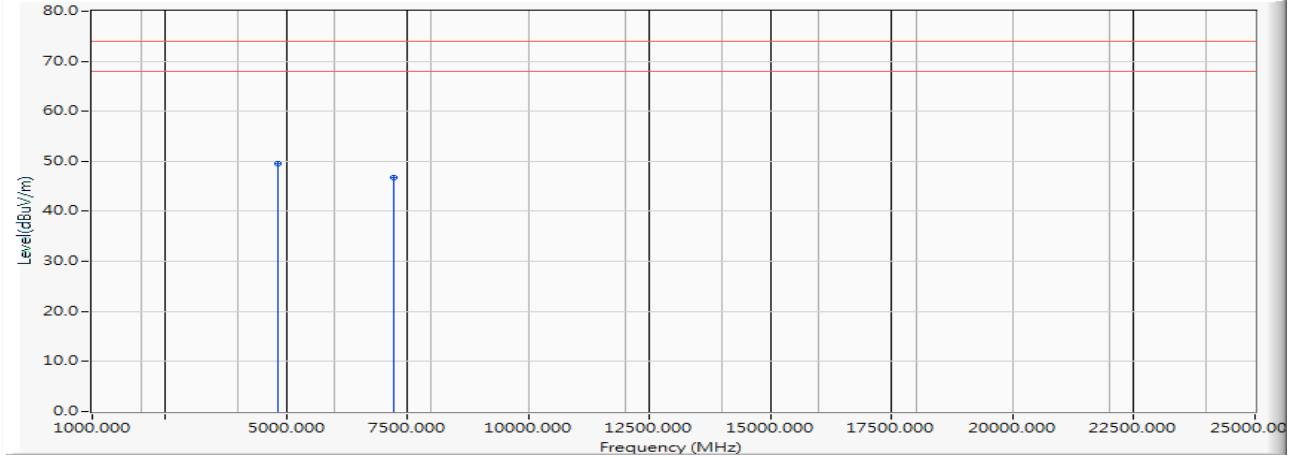

		Frequency (MHz)	Correct Factor (dB)	Reading Level (dBµV)	Measure Level (dBµV/m)	Margin (dB)	Limit (dBµV/m)	Detector Type
1	*	4824.000	-2.547	51.990	49.443	-24.557	74.000	PEAK
2		7236.000	0.811	45.900	46.711	-27.289	74.000	PEAK

Note:

1. All Readings below 1GHz are Quasi-Peak, above 1GHz are performed with peak and/or average measurements as necessary.
2. Measurement Level = Reading Level + Correct Factor.
3. Correct Factor = Antenna factor + Cable loss – Amplifier gain.
4. The average measurement was not performed when the peak measured data under the limit of average detection.
5. The emission levels of other frequencies are very lower than the limit and not show in test report.

Product : Software defined radio
 Test Item : Harmonic Radiated Emission
 Test Mode : Mode 2: Transmit_Patch (A1+ A2+ B1+ B2) (2412MHz)
 Test Date : 2018/02/22

Vertical

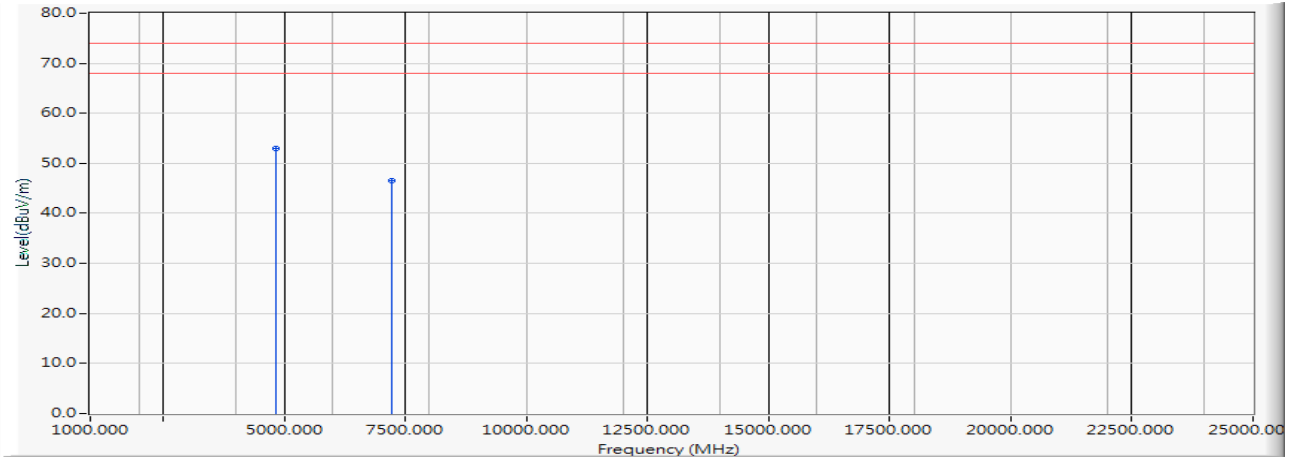

		Frequency (MHz)	Correct Factor (dB)	Reading Level (dBµV)	Measure Level (dBµV/m)	Margin (dB)	Limit (dBµV/m)	Detector Type
1	*	4824.000	-2.547	55.520	52.973	-21.027	74.000	PEAK
2		7236.000	0.811	45.630	46.441	-27.559	74.000	PEAK

Note:

1. All Readings below 1GHz are Quasi-Peak, above 1GHz are performed with peak and/or average measurements as necessary.
2. Measurement Level = Reading Level + Correct Factor.
3. Correct Factor = Antenna factor + Cable loss –Amplifier gain.
4. The average measurement was not performed when the peak measured data under the limit of average detection.
5. The emission levels of other frequencies are very lower than the limit and not show in test report.

Product : Software defined radio
 Test Item : Harmonic Radiated Emission
 Test Mode : Mode 2: Transmit_Patch (A1+ A2+ B1+ B2) (2437MHz)
 Test Date : 2018/02/22

Horizontal

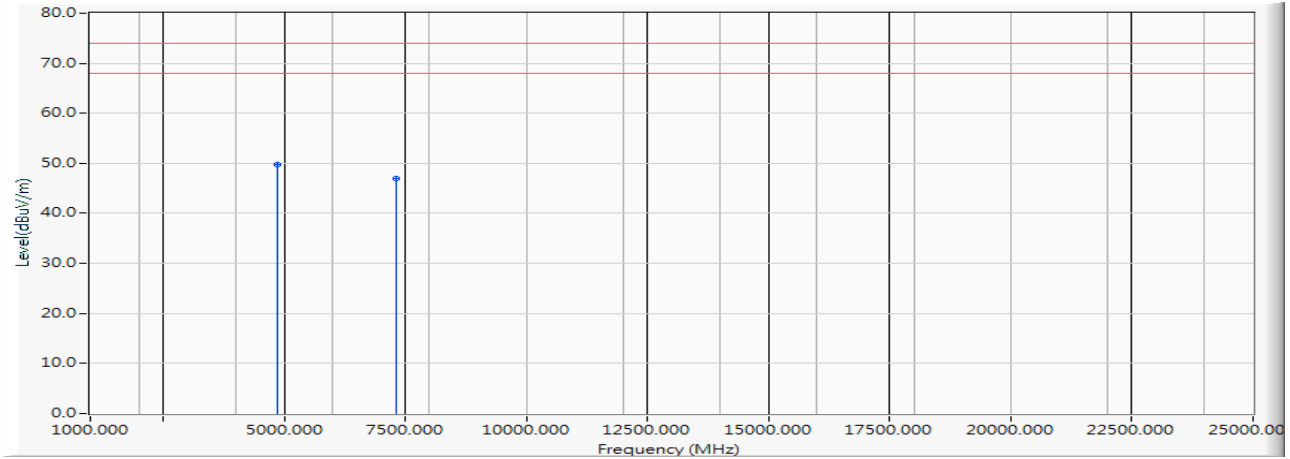

		Frequency (MHz)	Correct Factor (dB)	Reading Level (dBµV)	Measure Level (dBµV/m)	Margin (dB)	Limit (dBµV/m)	Detector Type
1	*	4874.000	-2.393	52.070	49.676	-24.324	74.000	PEAK
2		7311.000	0.810	46.080	46.890	-27.110	74.000	PEAK

Note:

1. All Readings below 1GHz are Quasi-Peak, above 1GHz are performed with peak and/or average measurements as necessary.
2. Measurement Level = Reading Level + Correct Factor.
3. Correct Factor = Antenna factor + Cable loss – Amplifier gain.
4. The average measurement was not performed when the peak measured data under the limit of average detection.
5. The emission levels of other frequencies are very lower than the limit and not show in test report.

Product : Software defined radio
 Test Item : Harmonic Radiated Emission
 Test Mode : Mode 2: Transmit_Patch (A1+ A2+ B1+ B2) (2437MHz)
 Test Date : 2018/02/22

Vertical

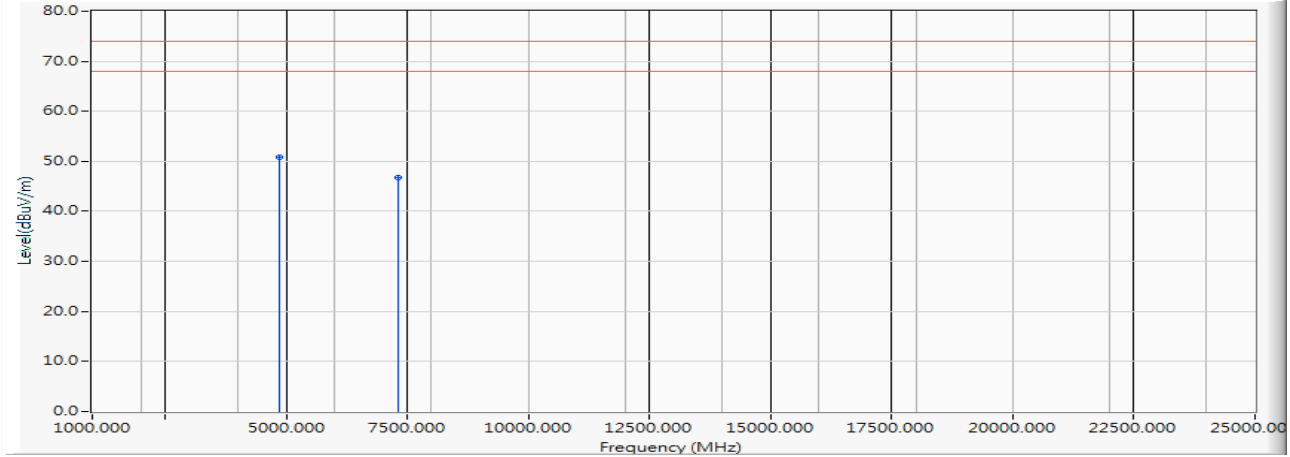

		Frequency (MHz)	Correct Factor (dB)	Reading Level (dBµV)	Measure Level (dBµV/m)	Margin (dB)	Limit (dBµV/m)	Detector Type
1	*	4874.000	-2.393	53.330	50.936	-23.064	74.000	PEAK
2		7311.000	0.810	45.890	46.700	-27.300	74.000	PEAK

Note:

1. All Readings below 1GHz are Quasi-Peak, above 1GHz are performed with peak and/or average measurements as necessary.
2. Measurement Level = Reading Level + Correct Factor.
3. Correct Factor = Antenna factor + Cable loss – Amplifier gain.
4. The average measurement was not performed when the peak measured data under the limit of average detection.
5. The emission levels of other frequencies are very lower than the limit and not show in test report.

Product : Software defined radio
 Test Item : Harmonic Radiated Emission
 Test Mode : Mode 2: Transmit_Patch (A1+ A2+ B1+ B2) (2462MHz)
 Test Date : 2018/02/22

Horizontal

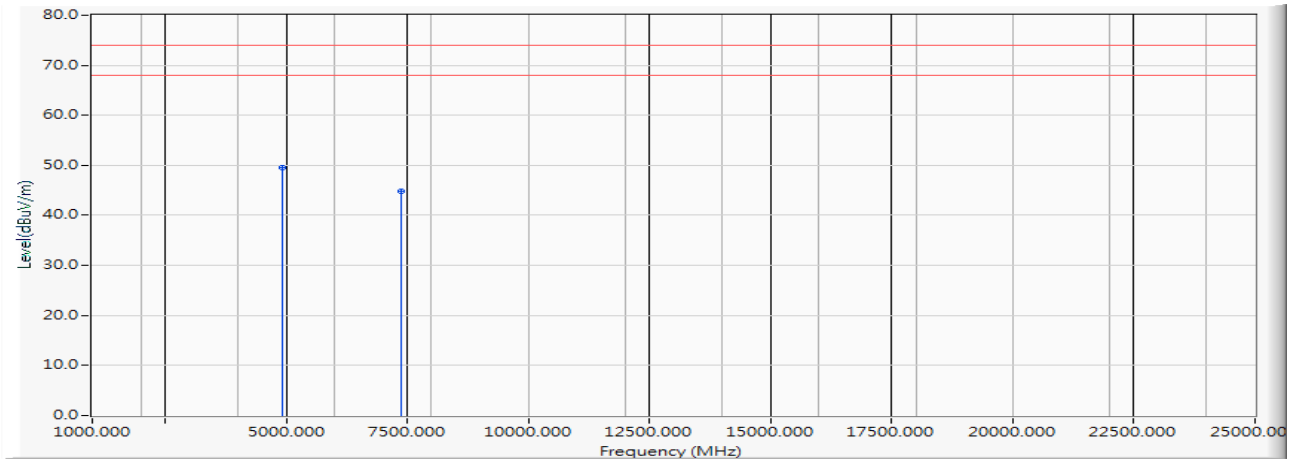

		Frequency (MHz)	Correct Factor (dB)	Reading Level (dBμV)	Measure Level (dBμV/m)	Margin (dB)	Limit (dBμV/m)	Detector Type
1	*	4924.000	-2.402	51.890	49.488	-24.512	74.000	PEAK
2		7386.000	0.806	44.120	44.926	-29.074	74.000	PEAK

Note:

1. All Readings below 1GHz are Quasi-Peak, above 1GHz are performed with peak and/or average measurements as necessary.
2. Measurement Level = Reading Level + Correct Factor.
3. Correct Factor = Antenna factor + Cable loss – Amplifier gain.
4. The average measurement was not performed when the peak measured data under the limit of average detection.
5. The emission levels of other frequencies are very lower than the limit and not show in test report.

Product : Software defined radio
 Test Item : Harmonic Radiated Emission
 Test Mode : Mode 2: Transmit_Patch (A1+ A2+ B1+ B2) (2462MHz)
 Test Date : 2018/02/22

Vertical

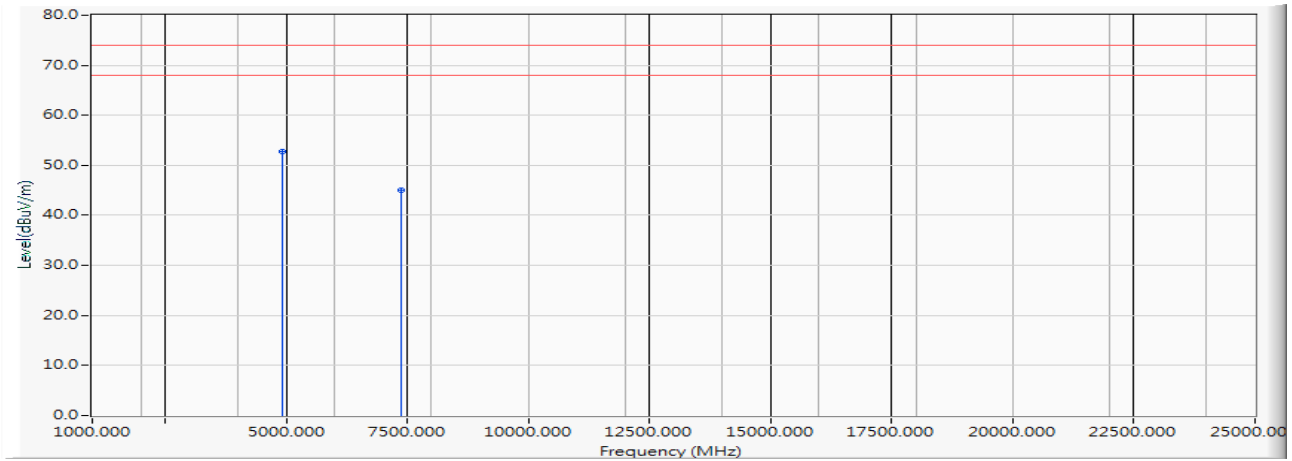

		Frequency (MHz)	Correct Factor (dB)	Reading Level (dBμV)	Measure Level (dBμV/m)	Margin (dB)	Limit (dBμV/m)	Detector Type
1	*	4924.000	-2.402	55.250	52.848	-21.152	74.000	PEAK
2		7386.000	0.806	44.140	44.946	-29.054	74.000	PEAK

Note:

1. All Readings below 1GHz are Quasi-Peak, above 1GHz are performed with peak and/or average measurements as necessary.
2. Measurement Level = Reading Level + Correct Factor.
3. Correct Factor = Antenna factor + Cable loss – Amplifier gain.
4. The average measurement was not performed when the peak measured data under the limit of average detection.
5. The emission levels of other frequencies are very lower than the limit and not show in test report.

Product : Software defined radio
 Test Item : Harmonic Radiated Emission
 Test Mode : Mode 2: Transmit_Patch (B1+ B2) (2412MHz)
 Test Date : 2018/02/22

Horizontal

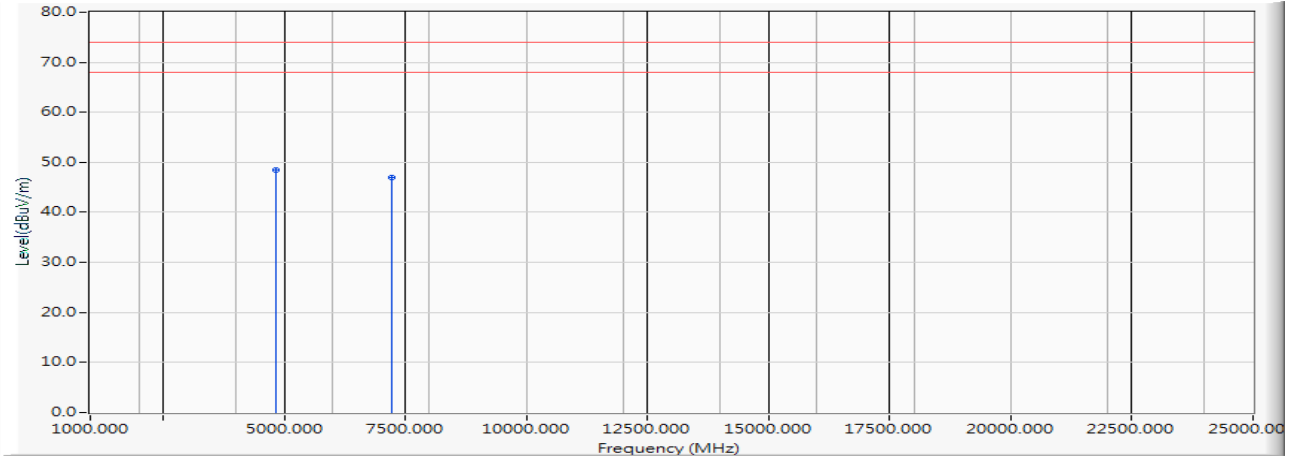

		Frequency (MHz)	Correct Factor (dB)	Reading Level (dBµV)	Measure Level (dBµV/m)	Margin (dB)	Limit (dBµV/m)	Detector Type
1	*	4824.000	-2.547	50.950	48.403	-25.597	74.000	PEAK
2		7236.000	0.811	46.160	46.971	-27.029	74.000	PEAK

Note:

1. All Readings below 1GHz are Quasi-Peak, above 1GHz are performed with peak and/or average measurements as necessary.
2. Measurement Level = Reading Level + Correct Factor.
3. Correct Factor = Antenna factor + Cable loss – Amplifier gain.
4. The average measurement was not performed when the peak measured data under the limit of average detection.
5. The emission levels of other frequencies are very lower than the limit and not show in test report.

Product : Software defined radio
 Test Item : Harmonic Radiated Emission
 Test Mode : Mode 2: Transmit_Patch (B1+ B2) (2412MHz)
 Test Date : 2018/02/22

Vertical

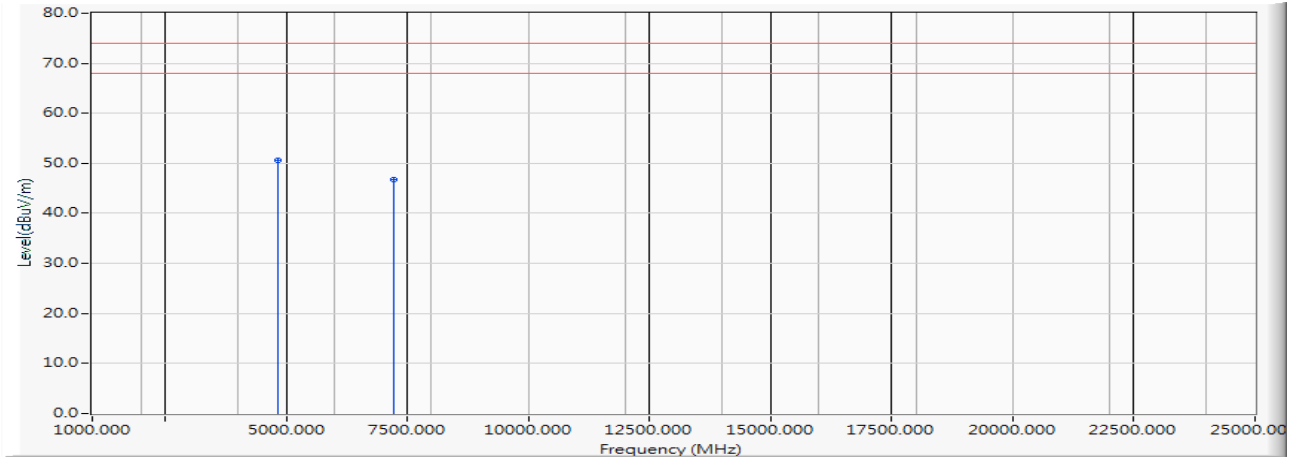

		Frequency (MHz)	Correct Factor (dB)	Reading Level (dBμV)	Measure Level (dBμV/m)	Margin (dB)	Limit (dBμV/m)	Detector Type
1	*	4824.000	-2.547	53.130	50.583	-23.417	74.000	PEAK
2		7236.000	0.811	45.850	46.661	-27.339	74.000	PEAK

Note:

1. All Readings below 1GHz are Quasi-Peak, above 1GHz are performed with peak and/or average measurements as necessary.
2. Measurement Level = Reading Level + Correct Factor.
3. Correct Factor = Antenna factor + Cable loss – Amplifier gain.
4. The average measurement was not performed when the peak measured data under the limit of average detection.
5. The emission levels of other frequencies are very lower than the limit and not show in test report.

Product : Software defined radio
 Test Item : Harmonic Radiated Emission
 Test Mode : Mode 2: Transmit_Patch (B1+ B2) (2437MHz)
 Test Date : 2018/02/22

Horizontal

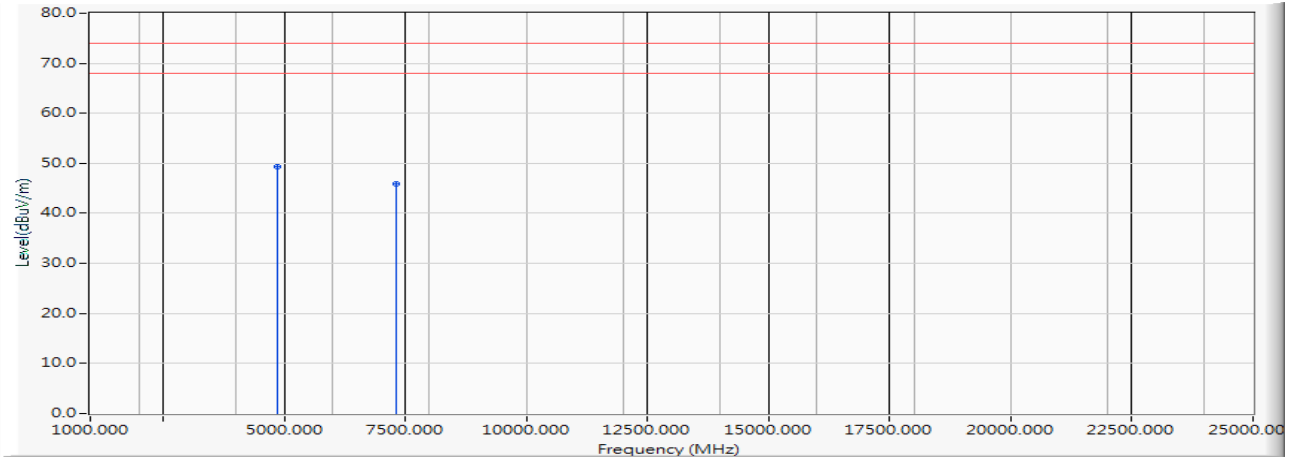

		Frequency (MHz)	Correct Factor (dB)	Reading Level (dBµV)	Measure Level (dBµV/m)	Margin (dB)	Limit (dBµV/m)	Detector Type
1	*	4874.000	-2.393	51.740	49.346	-24.654	74.000	PEAK
2		7311.000	0.810	45.100	45.910	-28.090	74.000	PEAK

Note:

1. All Readings below 1GHz are Quasi-Peak, above 1GHz are performed with peak and/or average measurements as necessary.
2. Measurement Level = Reading Level + Correct Factor.
3. Correct Factor = Antenna factor + Cable loss – Amplifier gain.
4. The average measurement was not performed when the peak measured data under the limit of average detection.
5. The emission levels of other frequencies are very lower than the limit and not show in test report.

Product : Software defined radio
 Test Item : Harmonic Radiated Emission
 Test Mode : Mode 2: Transmit_Patch (B1+ B2) (2437MHz)
 Test Date : 2018/02/22

Vertical

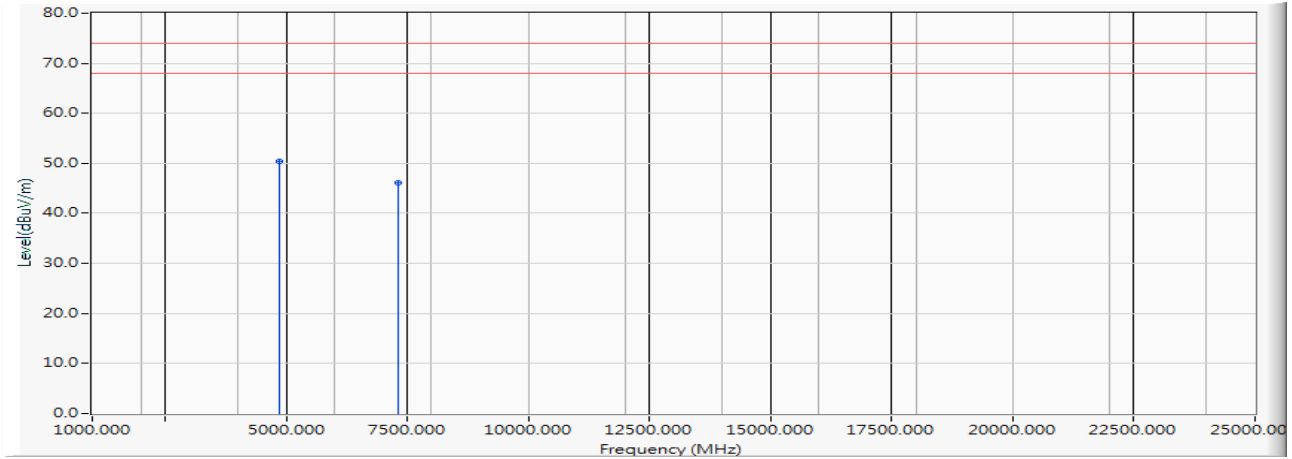

		Frequency (MHz)	Correct Factor (dB)	Reading Level (dBµV)	Measure Level (dBµV/m)	Margin (dB)	Limit (dBµV/m)	Detector Type
1	*	4874.000	-2.393	52.730	50.336	-23.664	74.000	PEAK
2		7311.000	0.810	45.390	46.200	-27.800	74.000	PEAK

Note:

1. All Readings below 1GHz are Quasi-Peak, above 1GHz are performed with peak and/or average measurements as necessary.
2. Measurement Level = Reading Level + Correct Factor.
3. Correct Factor = Antenna factor + Cable loss – Amplifier gain.
4. The average measurement was not performed when the peak measured data under the limit of average detection.
5. The emission levels of other frequencies are very lower than the limit and not show in test report.

Product : Software defined radio
 Test Item : Harmonic Radiated Emission
 Test Mode : Mode 2: Transmit_Patch (B1+ B2) (2462MHz)
 Test Date : 2018/02/22

Horizontal

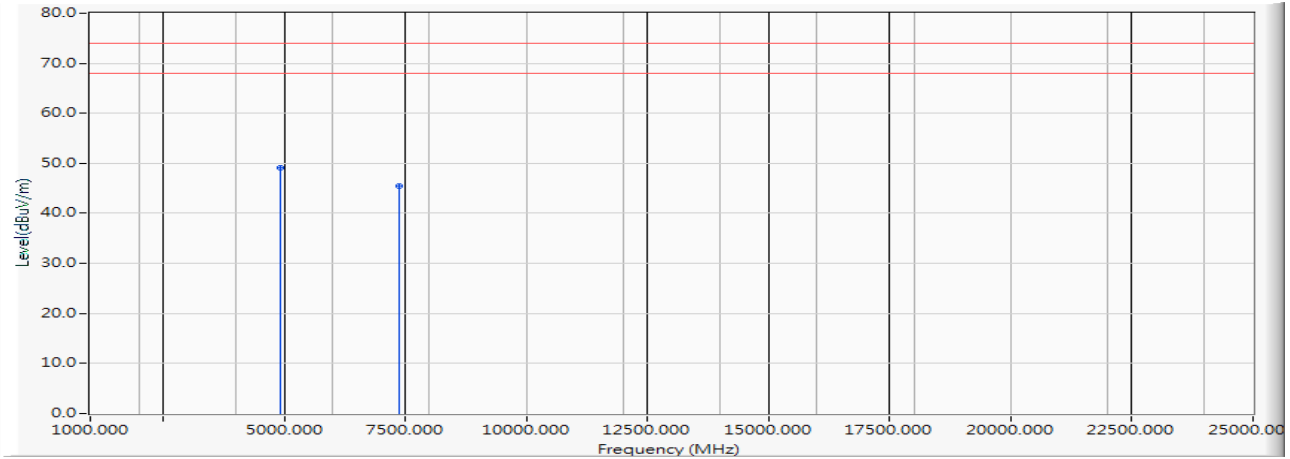

		Frequency (MHz)	Correct Factor (dB)	Reading Level (dBµV)	Measure Level (dBµV/m)	Margin (dB)	Limit (dBµV/m)	Detector Type
1	*	4924.000	-2.402	51.480	49.078	-24.922	74.000	PEAK
2		7386.000	0.806	44.690	45.496	-28.504	74.000	PEAK

Note:

1. All Readings below 1GHz are Quasi-Peak, above 1GHz are performed with peak and/or average measurements as necessary.
2. Measurement Level = Reading Level + Correct Factor.
3. Correct Factor = Antenna factor + Cable loss – Amplifier gain.
4. The average measurement was not performed when the peak measured data under the limit of average detection.
5. The emission levels of other frequencies are very lower than the limit and not show in test report.

Product : Software defined radio
 Test Item : Harmonic Radiated Emission
 Test Mode : Mode 2: Transmit_Patch (B1+ B2) (2462MHz)
 Test Date : 2018/02/22

Vertical

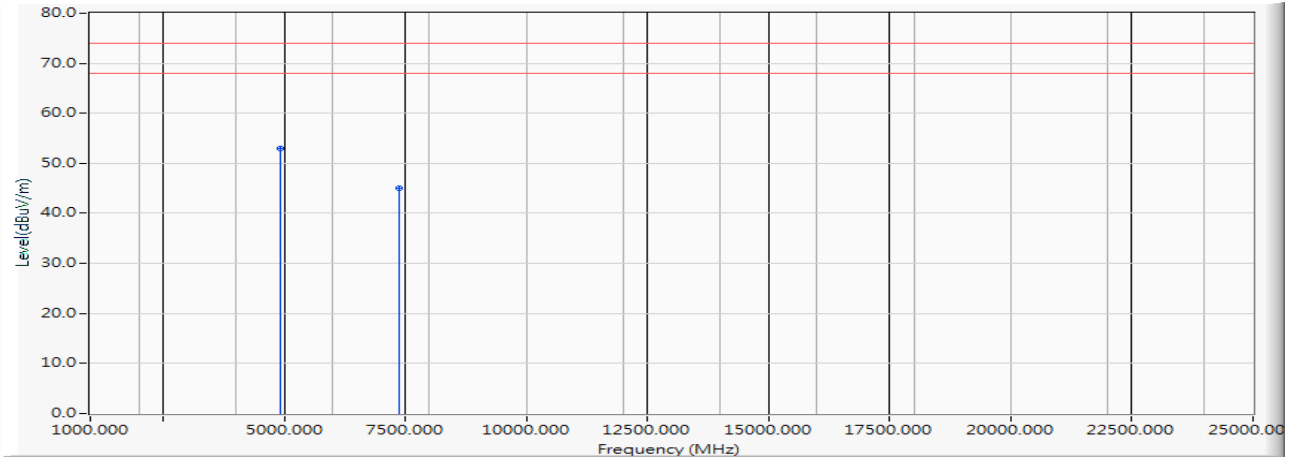

		Frequency (MHz)	Correct Factor (dB)	Reading Level (dBµV)	Measure Level (dBµV/m)	Margin (dB)	Limit (dBµV/m)	Detector Type
1	*	4924.000	-2.402	55.280	52.878	-21.122	74.000	PEAK
2		7386.000	0.806	44.300	45.106	-28.894	74.000	PEAK

Note:

1. All Readings below 1GHz are Quasi-Peak, above 1GHz are performed with peak and/or average measurements as necessary.
2. Measurement Level = Reading Level + Correct Factor.
3. Correct Factor = Antenna factor + Cable loss – Amplifier gain.
4. The average measurement was not performed when the peak measured data under the limit of average detection.
5. The emission levels of other frequencies are very lower than the limit and not show in test report.

Product : Software defined radio
 Test Item : General Radiated Emission
 Test Mode : Mode 1: Transmit_Dipole (A1+ A2) (2437MHz)
 Test Date : 2019/02/24

Horizontal

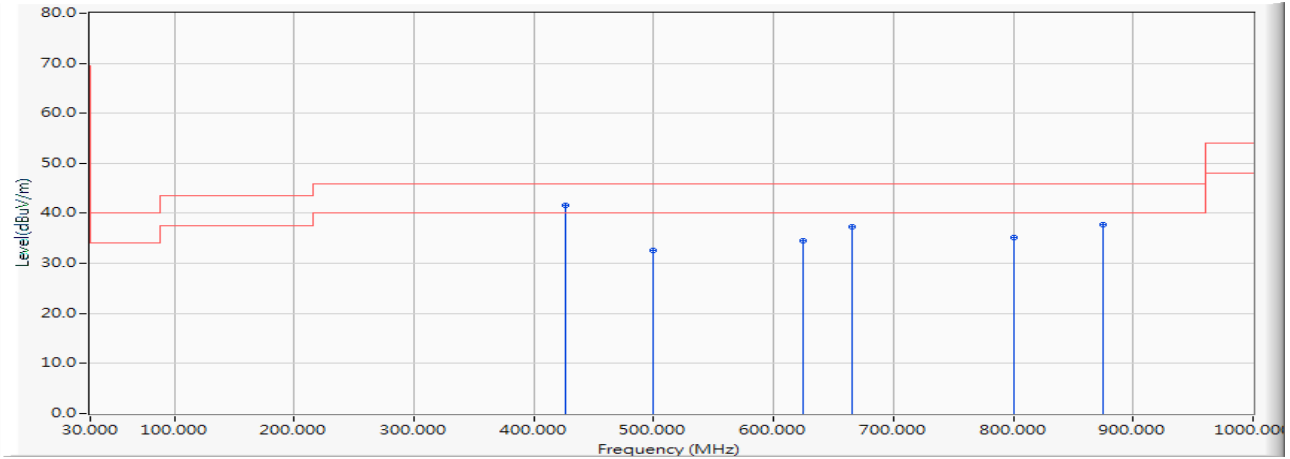

		Frequency (MHz)	Correct Factor (dB)	Reading Level (dBµV)	Measure Level (dBµV/m)	Margin (dB)	Limit (dBµV/m)	Detector Type
1	*	426.435	-6.476	47.996	41.519	-4.481	46.000	QUASIPeAK
2		499.536	-5.026	37.567	32.540	-13.460	46.000	QUASIPeAK
3		624.652	-2.618	37.206	34.589	-11.411	46.000	QUASIPeAK
4		665.420	-2.133	39.500	37.367	-8.633	46.000	QUASIPeAK
5		800.377	-0.125	35.276	35.151	-10.849	46.000	QUASIPeAK
6		874.884	0.791	37.061	37.852	-8.148	46.000	QUASIPeAK

Note:

1. All Readings below 1GHz are Quasi-Peak, above 1GHz are performed with peak and/or average measurements as necessary.
2. Measurement Level = Reading Level + Correct Factor.
3. Correct Factor = Antenna factor + Cable loss – Amplifier gain.
4. The emission levels of other frequencies are very lower than the limit and not show in test report.
5. No emission found between lowest internal used/generated frequency to 30MHz.

Product : Software defined radio
 Test Item : General Radiated Emission
 Test Mode : Mode 1: Transmit_Dipole (A1+ A2) (2437MHz)
 Test Date : 2019/02/24

Vertical

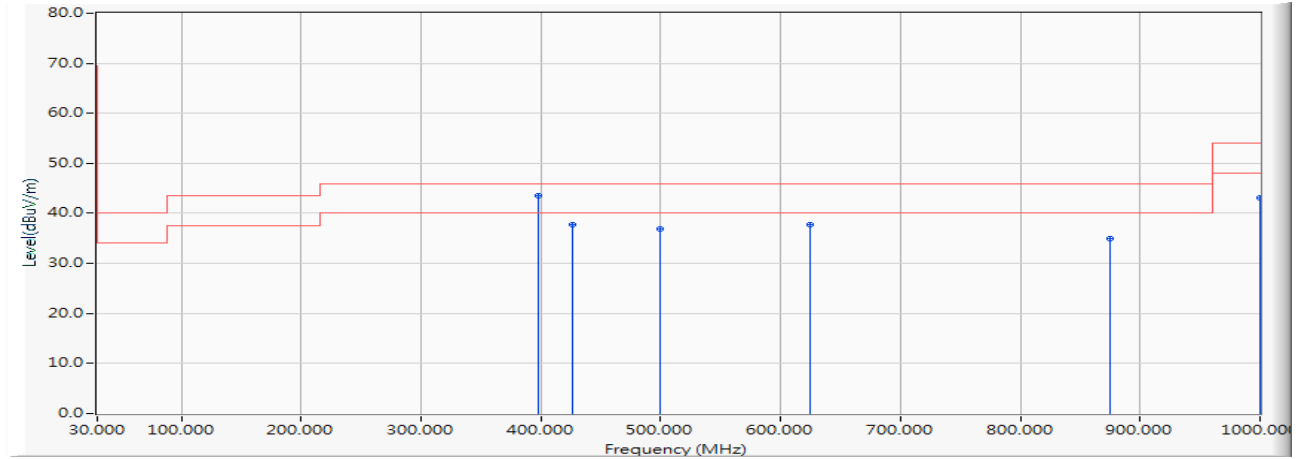

		Frequency (MHz)	Correct Factor (dB)	Reading Level (dBµV)	Measure Level (dBµV/m)	Margin (dB)	Limit (dBµV/m)	Detector Type
1	*	398.319	-7.157	50.603	43.447	-2.553	46.000	QUASIPeAK
2		426.435	-6.476	44.217	37.740	-8.260	46.000	QUASIPeAK
3		499.536	-5.026	41.965	36.938	-9.062	46.000	QUASIPeAK
4		624.652	-2.618	40.448	37.831	-8.169	46.000	QUASIPeAK
5		874.884	0.791	34.155	34.946	-11.054	46.000	QUASIPeAK
6		1000.000	2.410	40.740	43.150	-10.850	54.000	QUASIPeAK

Note:

1. All Readings below 1GHz are Quasi-Peak, above 1GHz are performed with peak and/or average measurements as necessary.
2. Measurement Level = Reading Level + Correct Factor.
3. Correct Factor = Antenna factor + Cable loss – Amplifier gain.
4. The emission levels of other frequencies are very lower than the limit and not show in test report.
5. No emission found between lowest internal used/generated frequency to 30MHz.

Product : Software defined radio
 Test Item : General Radiated Emission
 Test Mode : Mode 1: Transmit_Dipole (A1+ A2+ B1+ B2) (2437MHz)
 Test Date : 2019/02/24

Horizontal

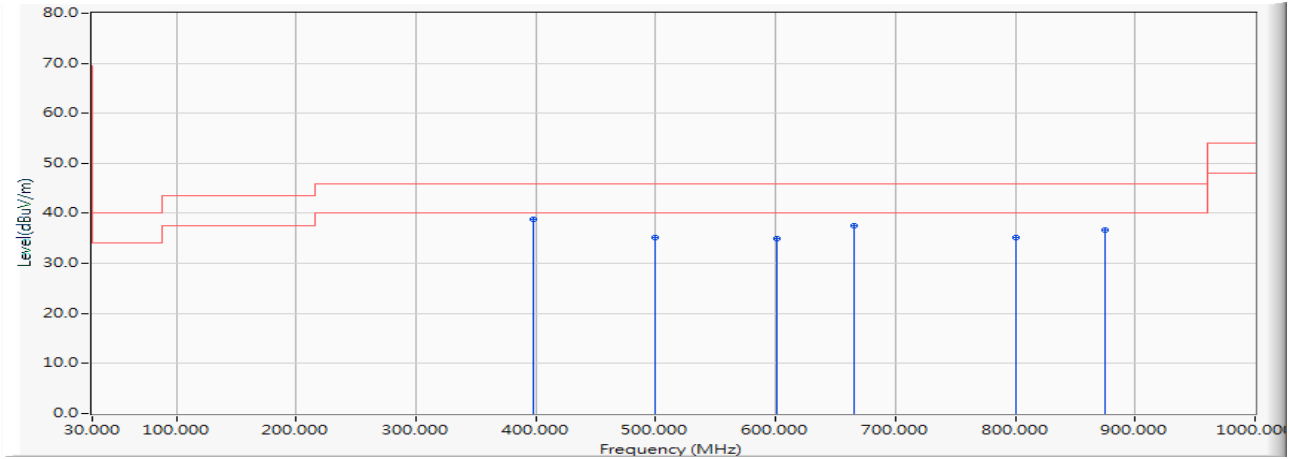

		Frequency (MHz)	Correct Factor (dB)	Reading Level (dBµV)	Measure Level (dBµV/m)	Margin (dB)	Limit (dBµV/m)	Detector Type
1	*	398.319	-7.157	46.065	38.909	-7.091	46.000	QUASIPeAK
2		499.536	-5.026	40.113	35.086	-10.914	46.000	QUASIPeAK
3		600.754	-2.816	37.875	35.060	-10.940	46.000	QUASIPeAK
4		665.420	-2.133	39.689	37.556	-8.444	46.000	QUASIPeAK
5		800.377	-0.125	35.368	35.243	-10.757	46.000	QUASIPeAK
6		874.884	0.791	35.917	36.708	-9.292	46.000	QUASIPeAK

Note:

1. All Readings below 1GHz are Quasi-Peak, above 1GHz are performed with peak and/or average measurements as necessary.
2. Measurement Level = Reading Level + Correct Factor.
3. Correct Factor = Antenna factor + Cable loss – Amplifier gain.
4. The emission levels of other frequencies are very lower than the limit and not show in test report.
5. No emission found between lowest internal used/generated frequency to 30MHz.

Product : Software defined radio
 Test Item : General Radiated Emission
 Test Mode : Mode 1: Transmit_Dipole (A1+ A2+ B1+ B2) (2437MHz)
 Test Date : 2019/02/24

Vertical

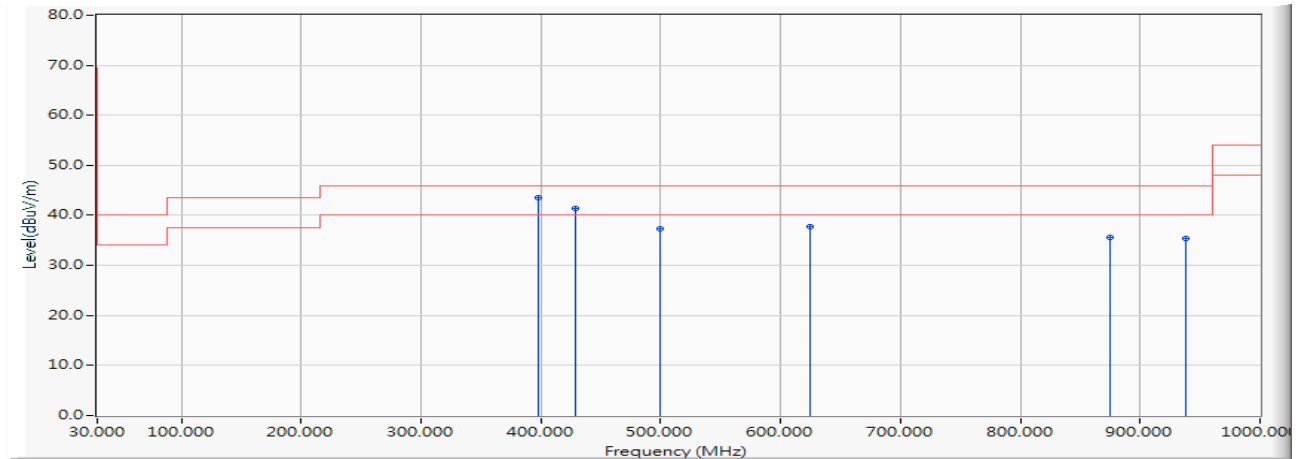

		Frequency (MHz)	Correct Factor (dB)	Reading Level (dBµV)	Measure Level (dBµV/m)	Margin (dB)	Limit (dBµV/m)	Detector Type
1	*	398.319	-7.157	50.643	43.487	-2.513	46.000	QUASIPEAK
2		429.246	-6.410	47.911	41.501	-4.499	46.000	QUASIPEAK
3		499.536	-5.026	42.283	37.256	-8.744	46.000	QUASIPEAK
4		624.652	-2.618	40.389	37.772	-8.228	46.000	QUASIPEAK
5		874.884	0.791	34.731	35.522	-10.478	46.000	QUASIPEAK
6		938.145	1.522	33.816	35.338	-10.662	46.000	QUASIPEAK

Note:

1. All Readings below 1GHz are Quasi-Peak, above 1GHz are performed with peak and/or average measurements as necessary.
2. Measurement Level = Reading Level + Correct Factor.
3. Correct Factor = Antenna factor + Cable loss – Amplifier gain.
4. The emission levels of other frequencies are very lower than the limit and not show in test report.
5. No emission found between lowest internal used/generated frequency to 30MHz.

Product : Software defined radio
 Test Item : General Radiated Emission
 Test Mode : Mode 1: Transmit_Dipole (B1+ B2) (2437MHz)
 Test Date : 2019/02/24

Horizontal

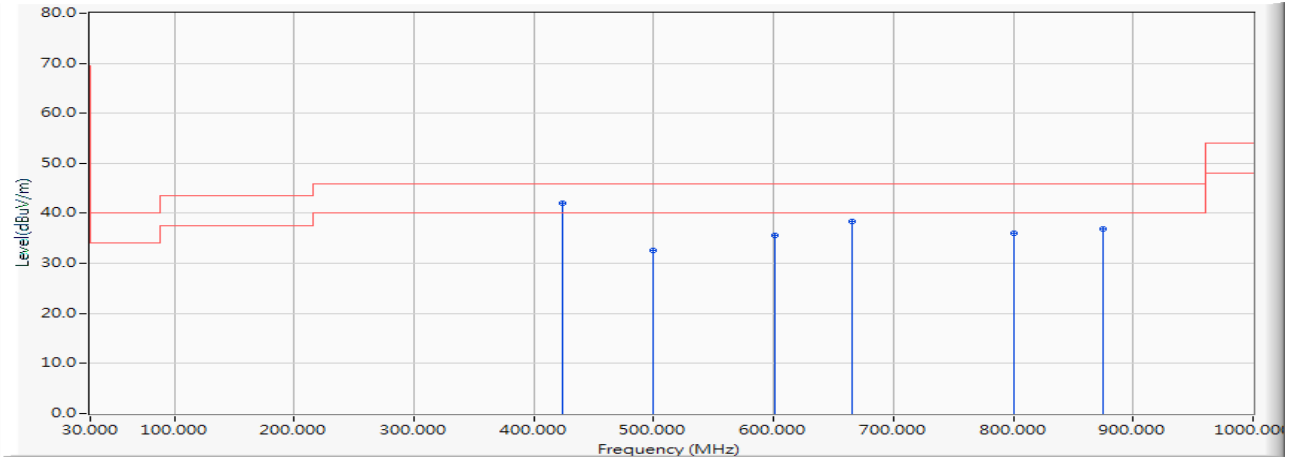

		Frequency (MHz)	Correct Factor (dB)	Reading Level (dBµV)	Measure Level (dBµV/m)	Margin (dB)	Limit (dBµV/m)	Detector Type
1	*	423.623	-6.547	48.510	41.963	-4.037	46.000	QUASIPeAK
2		499.536	-5.026	37.693	32.666	-13.334	46.000	QUASIPeAK
3		600.754	-2.816	38.453	35.638	-10.362	46.000	QUASIPeAK
4		665.420	-2.133	40.424	38.291	-7.709	46.000	QUASIPeAK
5		800.377	-0.125	36.245	36.120	-9.880	46.000	QUASIPeAK
6		874.884	0.791	36.131	36.922	-9.078	46.000	QUASIPeAK

Note:

1. All Readings below 1GHz are Quasi-Peak, above 1GHz are performed with peak and/or average measurements as necessary.
2. Measurement Level = Reading Level + Correct Factor.
3. Correct Factor = Antenna factor + Cable loss – Amplifier gain.
4. The emission levels of other frequencies are very lower than the limit and not show in test report.
5. No emission found between lowest internal used/generated frequency to 30MHz.

Product : Software defined radio
 Test Item : General Radiated Emission
 Test Mode : Mode 1: Transmit_Dipole (B1+ B2) (2437MHz)
 Test Date : 2019/02/24

Vertical

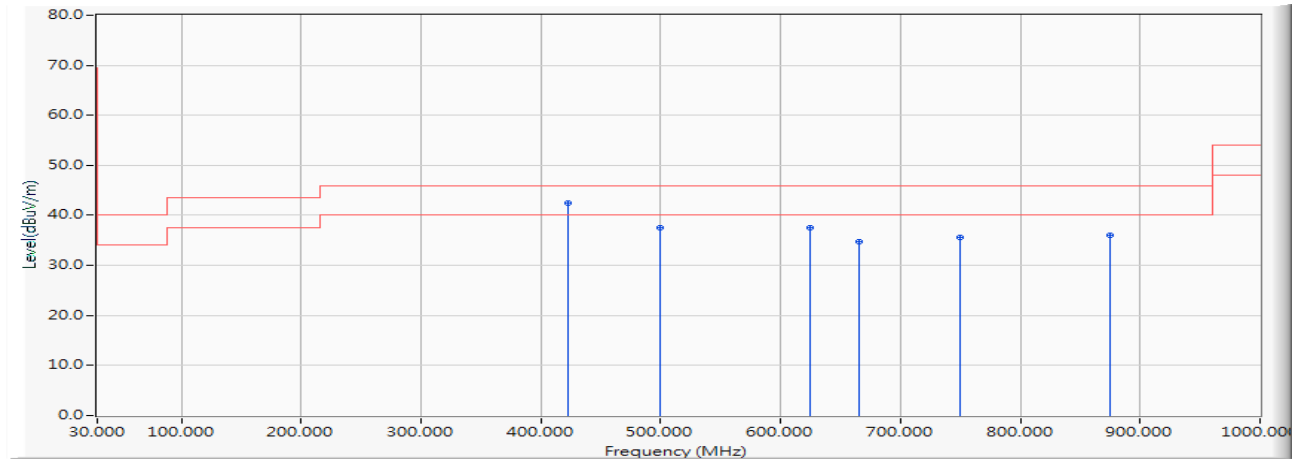

		Frequency (MHz)	Correct Factor (dB)	Reading Level (dBµV)	Measure Level (dBµV/m)	Margin (dB)	Limit (dBµV/m)	Detector Type
1	*	422.400	-6.574	49.000	42.426	-3.574	46.000	QUASIPEAK
2		499.536	-5.026	42.624	37.597	-8.403	46.000	QUASIPEAK
3		624.652	-2.618	40.245	37.628	-8.372	46.000	QUASIPEAK
4		665.420	-2.133	36.803	34.670	-11.330	46.000	QUASIPEAK
5		749.768	-0.724	36.368	35.644	-10.356	46.000	QUASIPEAK
6		874.884	0.791	35.315	36.106	-9.894	46.000	QUASIPEAK

Note:

1. All Readings below 1GHz are Quasi-Peak, above 1GHz are performed with peak and/or average measurements as necessary.
2. Measurement Level = Reading Level + Correct Factor.
3. Correct Factor = Antenna factor + Cable loss – Amplifier gain.
4. The emission levels of other frequencies are very lower than the limit and not show in test report.
5. No emission found between lowest internal used/generated frequency to 30MHz.

Product : Software defined radio
 Test Item : General Radiated Emission
 Test Mode : Mode 2: Transmit_Patch (A1+ A2) (2437MHz)
 Test Date : 2019/01/04

Horizontal

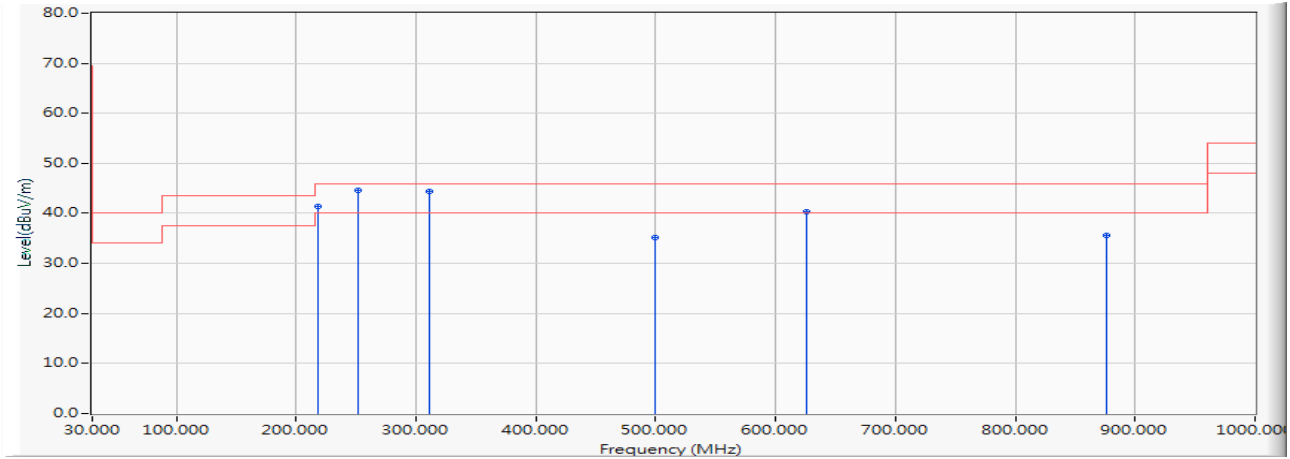

		Frequency (MHz)	Correct Factor (dB)	Reading Level (dBμV)	Measure Level (dBμV/m)	Margin (dB)	Limit (dBμV/m)	Detector Type
1		218.180	-12.549	53.994	41.445	-4.555	46.000	QUASIPEAK
2	*	251.160	-11.371	55.899	44.528	-1.472	46.000	QUASIPEAK
3		311.300	-9.404	53.719	44.315	-1.685	46.000	QUASIPEAK
4		499.480	-5.027	40.173	35.146	-10.854	46.000	QUASIPEAK
5		625.580	-2.612	42.943	40.331	-5.669	46.000	QUASIPEAK
6		875.840	0.801	34.878	35.679	-10.321	46.000	QUASIPEAK

Note:

1. All Readings below 1GHz are Quasi-Peak, above 1GHz are performed with peak and/or average measurements as necessary.
2. Measurement Level = Reading Level + Correct Factor.
3. Correct Factor = Antenna factor + Cable loss – Amplifier gain.
4. The emission levels of other frequencies are very lower than the limit and not show in test report.
5. No emission found between lowest internal used/generated frequency to 30MHz.

Product : Software defined radio
 Test Item : General Radiated Emission
 Test Mode : Mode 2: Transmit_Patch (A1+ A2) (2437MHz)
 Test Date : 2019/01/04

Vertical

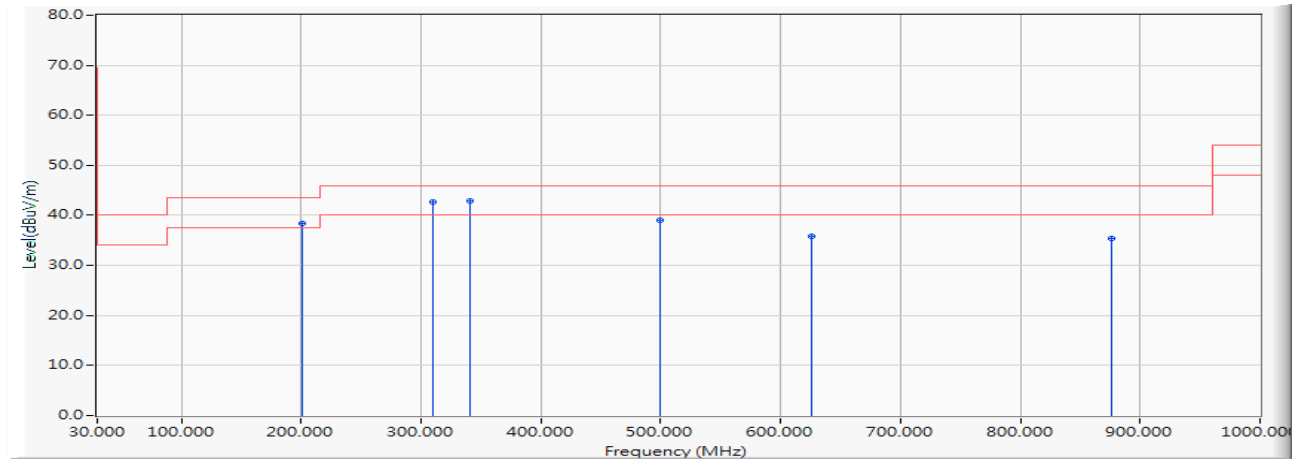

		Frequency (MHz)	Correct Factor (dB)	Reading Level (dBµV)	Measure Level (dBµV/m)	Margin (dB)	Limit (dBµV/m)	Detector Type
1		200.720	-13.222	51.564	38.342	-5.158	43.500	QUASIPeAK
2		309.360	-9.453	52.123	42.670	-3.330	46.000	QUASIPeAK
3	*	340.400	-8.752	51.552	42.800	-3.200	46.000	QUASIPeAK
4		499.480	-5.027	44.119	39.092	-6.908	46.000	QUASIPeAK
5		625.580	-2.612	38.456	35.844	-10.156	46.000	QUASIPeAK
6		875.840	0.801	34.518	35.319	-10.681	46.000	QUASIPeAK

Note:

1. All Readings below 1GHz are Quasi-Peak, above 1GHz are performed with peak and/or average measurements as necessary.
2. Measurement Level = Reading Level + Correct Factor.
3. Correct Factor = Antenna factor + Cable loss – Amplifier gain.
4. The emission levels of other frequencies are very lower than the limit and not show in test report.
5. No emission found between lowest internal used/generated frequency to 30MHz.

Product : Software defined radio
 Test Item : General Radiated Emission
 Test Mode : Mode 2: Transmit_Patch (A1+ A2+ B1+ B2) (2437MHz)
 Test Date : 2019/01/04

Horizontal

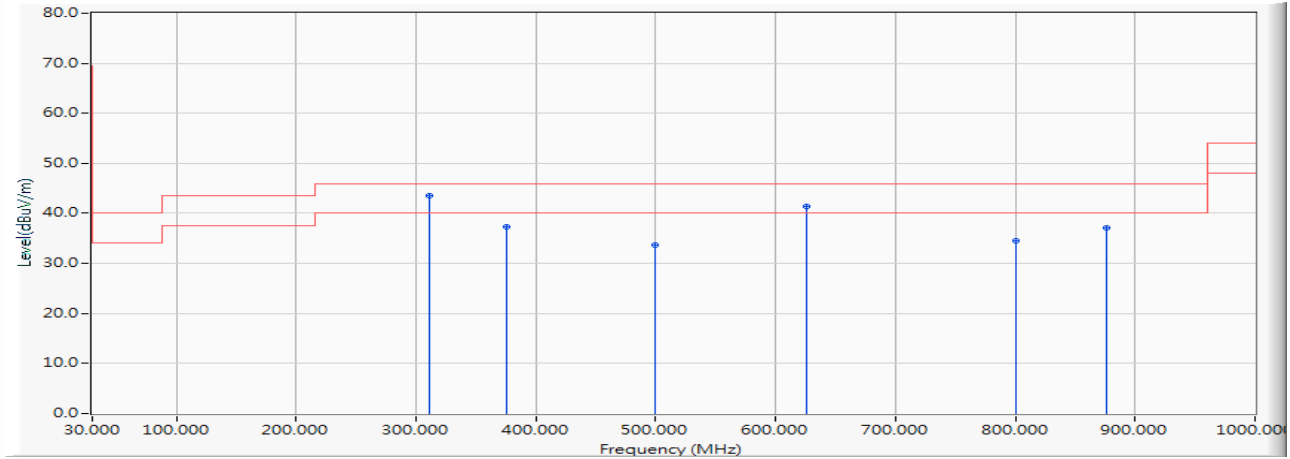

		Frequency (MHz)	Correct Factor (dB)	Reading Level (dBμV)	Measure Level (dBμV/m)	Margin (dB)	Limit (dBμV/m)	Detector Type
1	*	311.300	-9.404	53.048	43.644	-2.356	46.000	QUASIPeAK
2		375.320	-7.812	45.142	37.330	-8.670	46.000	QUASIPeAK
3		499.480	-5.027	38.679	33.652	-12.348	46.000	QUASIPeAK
4		625.580	-2.612	43.923	41.311	-4.689	46.000	QUASIPeAK
5		800.180	-0.127	34.708	34.581	-11.419	46.000	QUASIPeAK
6		875.840	0.801	36.212	37.013	-8.987	46.000	QUASIPeAK

Note:

1. All Readings below 1GHz are Quasi-Peak, above 1GHz are performed with peak and/or average measurements as necessary.
2. Measurement Level = Reading Level + Correct Factor.
3. Correct Factor = Antenna factor + Cable loss – Amplifier gain.
4. The emission levels of other frequencies are very lower than the limit and not show in test report.
5. No emission found between lowest internal used/generated frequency to 30MHz.

Product : Software defined radio
 Test Item : General Radiated Emission
 Test Mode : Mode 2: Transmit_Patch (A1+ A2+ B1+ B2) (2437MHz)
 Test Date : 2019/01/04

Vertical

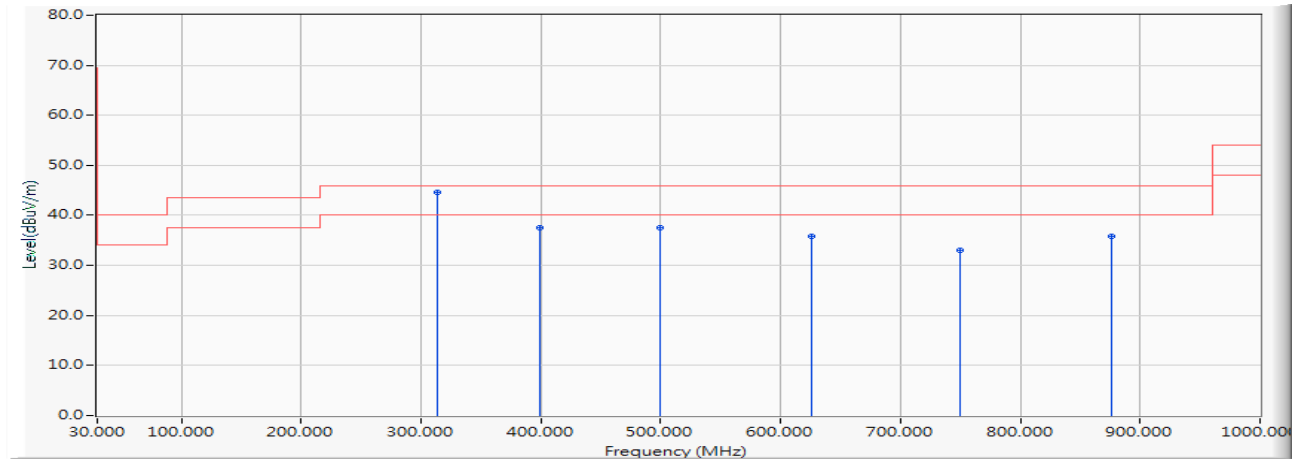

		Frequency (MHz)	Correct Factor (dB)	Reading Level (dBµV)	Measure Level (dBµV/m)	Margin (dB)	Limit (dBµV/m)	Detector Type
1	*	313.240	-9.365	53.939	44.574	-1.426	46.000	QUASIPeAK
2		398.600	-7.146	44.757	37.611	-8.389	46.000	QUASIPeAK
3		499.480	-5.027	42.569	37.542	-8.458	46.000	QUASIPeAK
4		625.580	-2.612	38.478	35.866	-10.134	46.000	QUASIPeAK
5		749.740	-0.724	33.741	33.017	-12.983	46.000	QUASIPeAK
6		875.840	0.801	35.081	35.882	-10.118	46.000	QUASIPeAK

Note:

1. All Readings below 1GHz are Quasi-Peak, above 1GHz are performed with peak and/or average measurements as necessary.
2. Measurement Level = Reading Level + Correct Factor.
3. Correct Factor = Antenna factor + Cable loss – Amplifier gain.
4. The emission levels of other frequencies are very lower than the limit and not show in test report.
5. No emission found between lowest internal used/generated frequency to 30MHz.

Product : Software defined radio
 Test Item : General Radiated Emission
 Test Mode : Mode 2: Transmit_Patch (B1+ B2) (2437MHz)
 Test Date : 2019/01/04

Horizontal

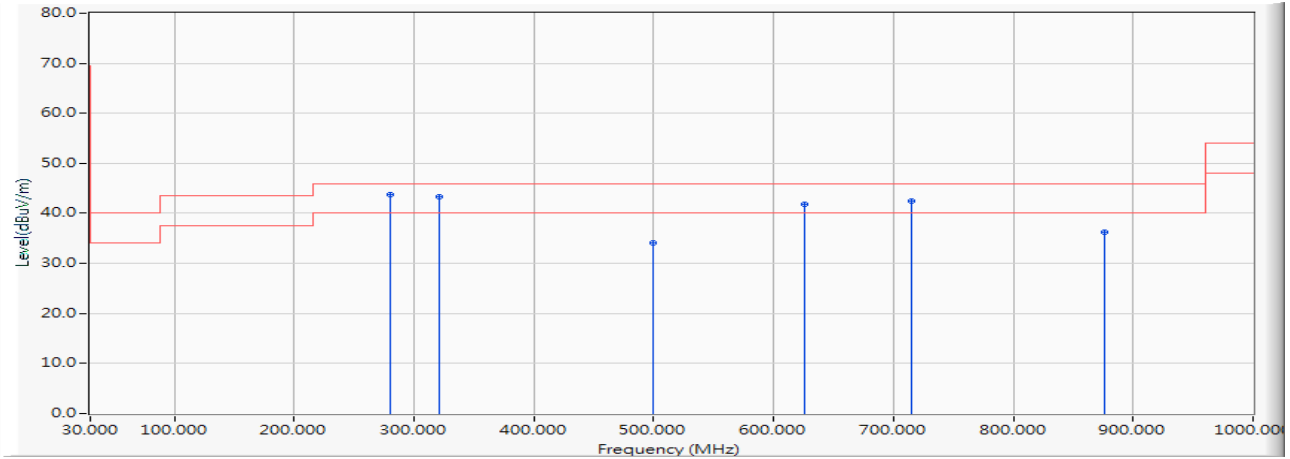

		Frequency (MHz)	Correct Factor (dB)	Reading Level (dBμV)	Measure Level (dBμV/m)	Margin (dB)	Limit (dBμV/m)	Detector Type
1	*	280.260	-10.111	53.870	43.759	-2.241	46.000	QUASIPeAK
2		321.000	-9.190	52.572	43.382	-2.618	46.000	QUASIPeAK
3		499.480	-5.027	39.069	34.042	-11.958	46.000	QUASIPeAK
4		625.580	-2.612	44.461	41.849	-4.151	46.000	QUASIPeAK
5		714.820	-1.280	43.698	42.418	-3.582	46.000	QUASIPeAK
6		875.840	0.801	35.416	36.217	-9.783	46.000	QUASIPeAK

Note:

1. All Readings below 1GHz are Quasi-Peak, above 1GHz are performed with peak and/or average measurements as necessary.
2. Measurement Level = Reading Level + Correct Factor.
3. Correct Factor = Antenna factor + Cable loss – Amplifier gain.
4. The emission levels of other frequencies are very lower than the limit and not show in test report.
5. No emission found between lowest internal used/generated frequency to 30MHz.

Product : Software defined radio
 Test Item : General Radiated Emission
 Test Mode : Mode 2: Transmit_Patch (B1+ B2) (2437MHz)
 Test Date : 2019/01/04

Vertical

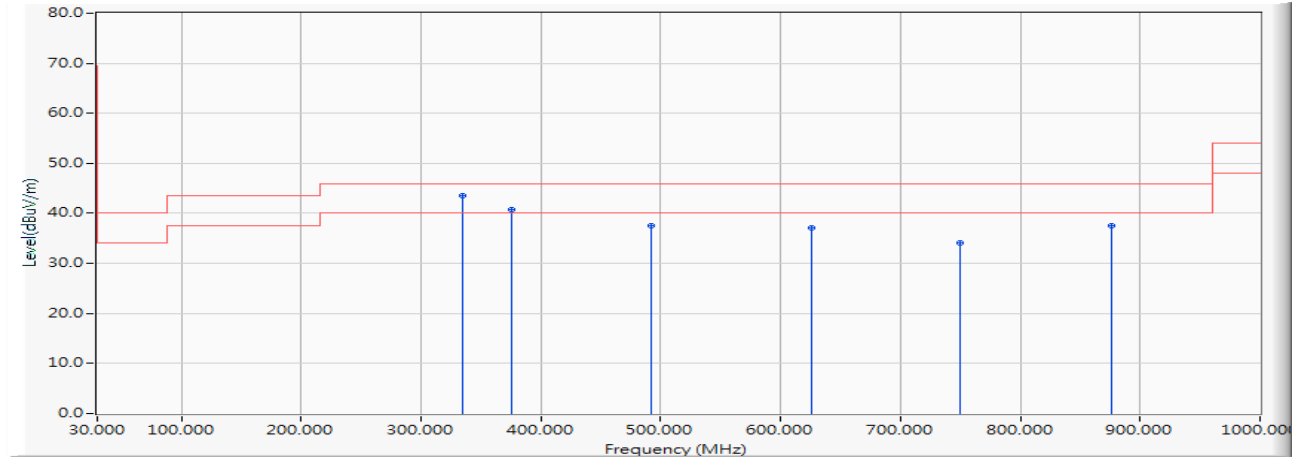

		Frequency (MHz)	Correct Factor (dB)	Reading Level (dBµV)	Measure Level (dBµV/m)	Margin (dB)	Limit (dBµV/m)	Detector Type
1	*	334.580	-8.878	52.456	43.578	-2.422	46.000	QUASIPEAK
2		375.320	-7.812	48.656	40.844	-5.156	46.000	QUASIPEAK
3		491.720	-5.170	42.737	37.567	-8.433	46.000	QUASIPEAK
4		625.580	-2.612	39.612	37.000	-9.000	46.000	QUASIPEAK
5		749.740	-0.724	34.745	34.021	-11.979	46.000	QUASIPEAK
6		875.840	0.801	36.798	37.599	-8.401	46.000	QUASIPEAK

Note:

1. All Readings below 1GHz are Quasi-Peak, above 1GHz are performed with peak and/or average measurements as necessary.
2. Measurement Level = Reading Level + Correct Factor.
3. Correct Factor = Antenna factor + Cable loss – Amplifier gain.
4. The emission levels of other frequencies are very lower than the limit and not show in test report.
5. No emission found between lowest internal used/generated frequency to 30MHz.

5. RF Antenna Conducted Test

5.1. Test Setup

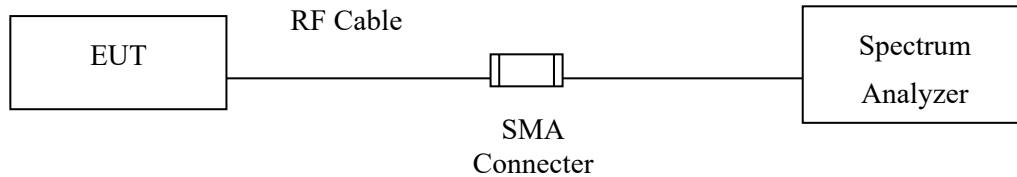

5.2. Limits

According to FCC Section 15.247(d). In any 100 kHz bandwidth outside the frequency band in which the spread spectrum or digitally modulated intentional radiator is operating, the radio frequency power that is produced by the intentional radiator shall be at least 20 dB below that in the 100 kHz bandwidth within the band that contains the highest level of the desired power, based on either an RF conducted or measurement, provided the transmitter demonstrates compliance with the peak conducted power limits. If the transmitter complies with the conducted power limits based on the use of RMS averaging over a time interval, the attenuation required under this paragraph shall be 30 dB instead of 20 dB.

5.3. Test Procedure

Tested according to DTS test procedure of KDB558074 section 8.5 DTS emissions in non-restricted frequency bands for compliance to FCC 47CFR 15.247 requirements.
Set RBW = 100 kHz, Set VBW > RBW, scan up through 10th harmonic.

5.4. Uncertainty

$\pm 1.23\text{dB}$

5.5. Test Result of RF Antenna Conducted Test

Product : Software defined radio
Test Item : RF Antenna Conducted Test
Test Mode : Mode 1: Transmit_Dipole (A1+ A2)
Test Date : 2018/12/07

Figure Channel 01 (Chain A1)

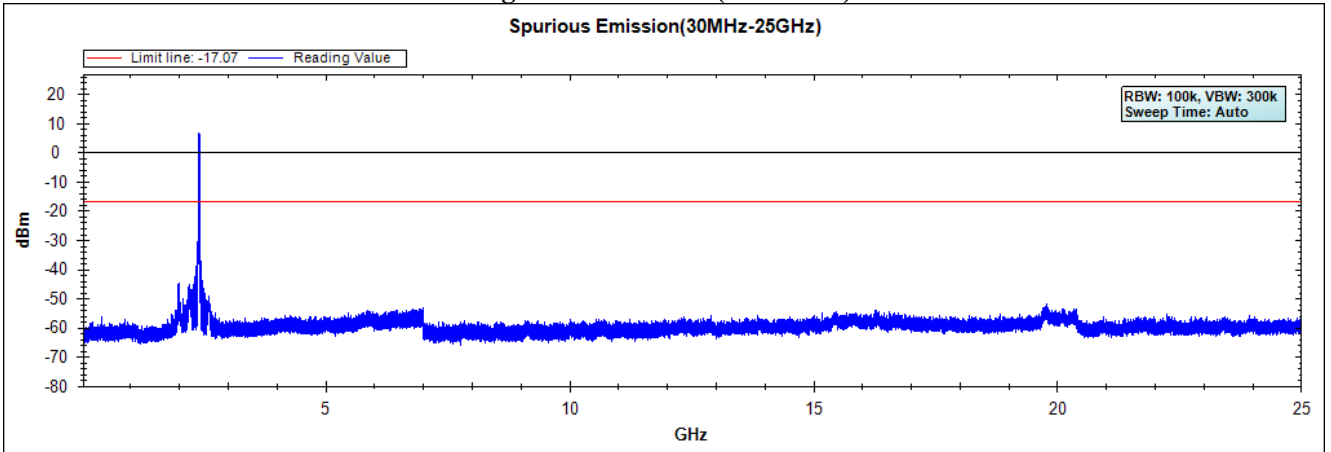

Figure Channel 01 (Chain A2)

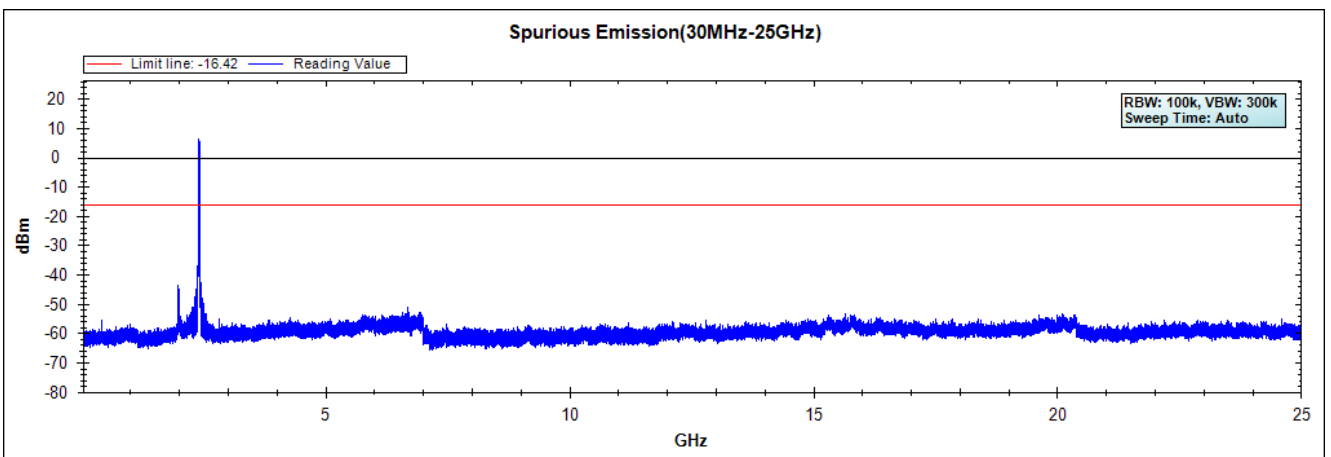

Figure Channel 06 (Chain A1)

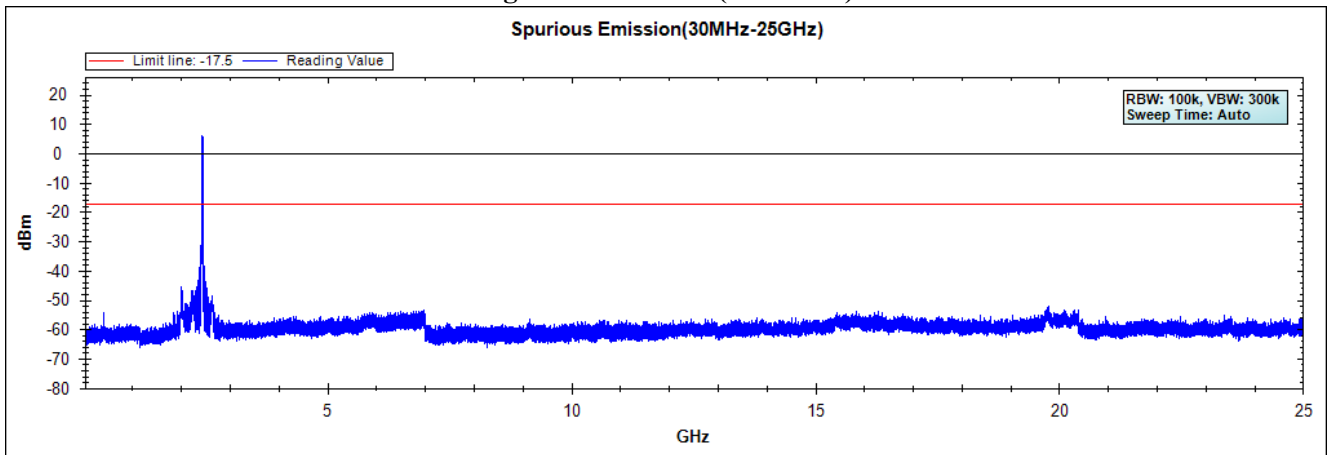

Figure Channel 06 (Chain A1)

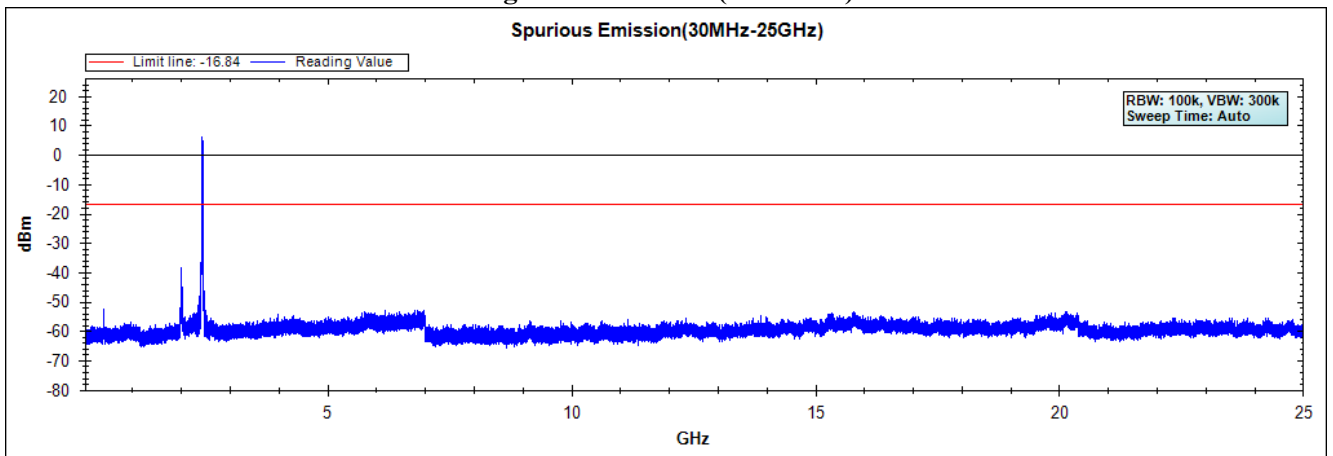

Figure Channel 11 (Chain A1)

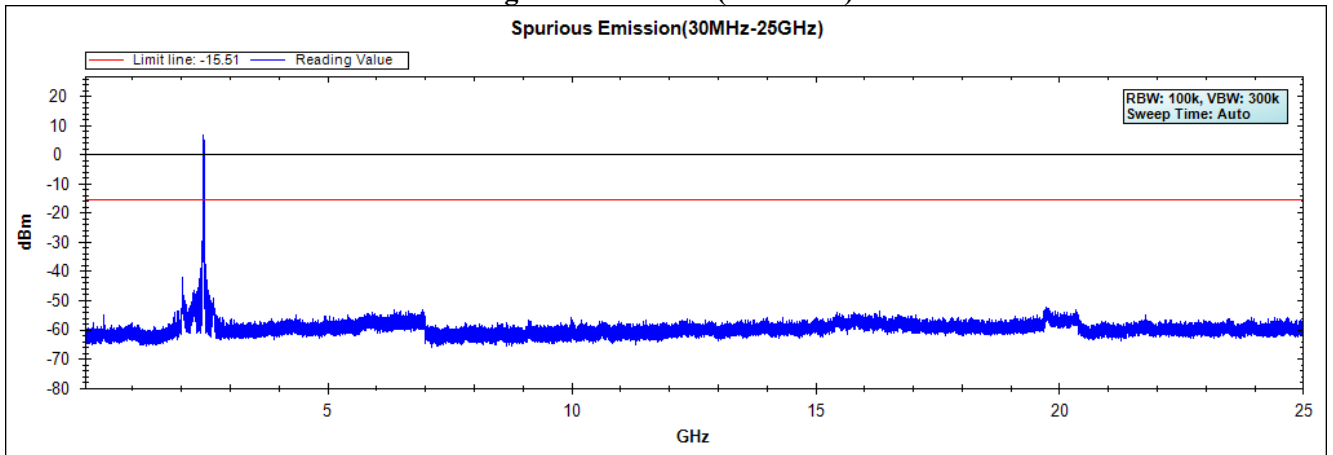
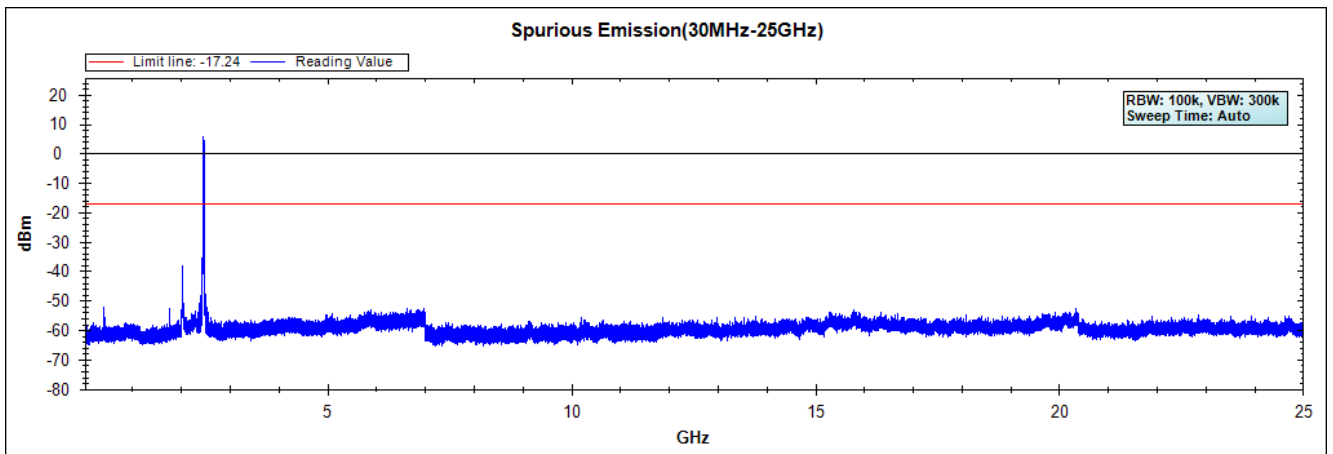

Figure Channel 11 (Chain A2)



Note: The above test pattern is synthesized by multiple of the frequency range.

Product : Software defined radio
Test Item : RF Antenna Conducted Test
Test Mode : Mode 1: Transmit_Dipole (A1+ A2+ B1+ B2)
Test Date : 2018/12/07

Figure Channel 01 (Chain A1)

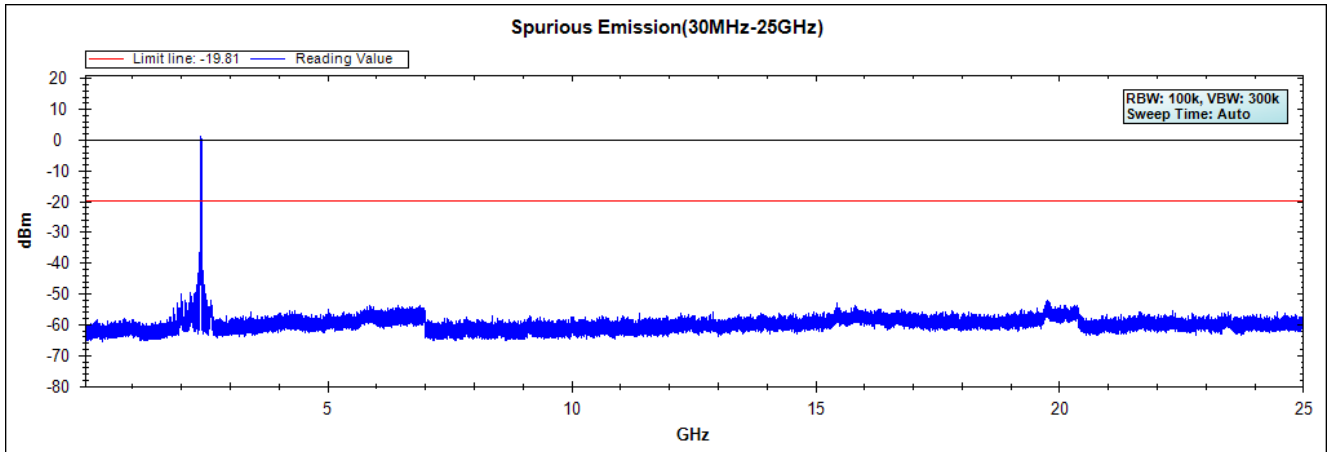

Figure Channel 01 (Chain A2)

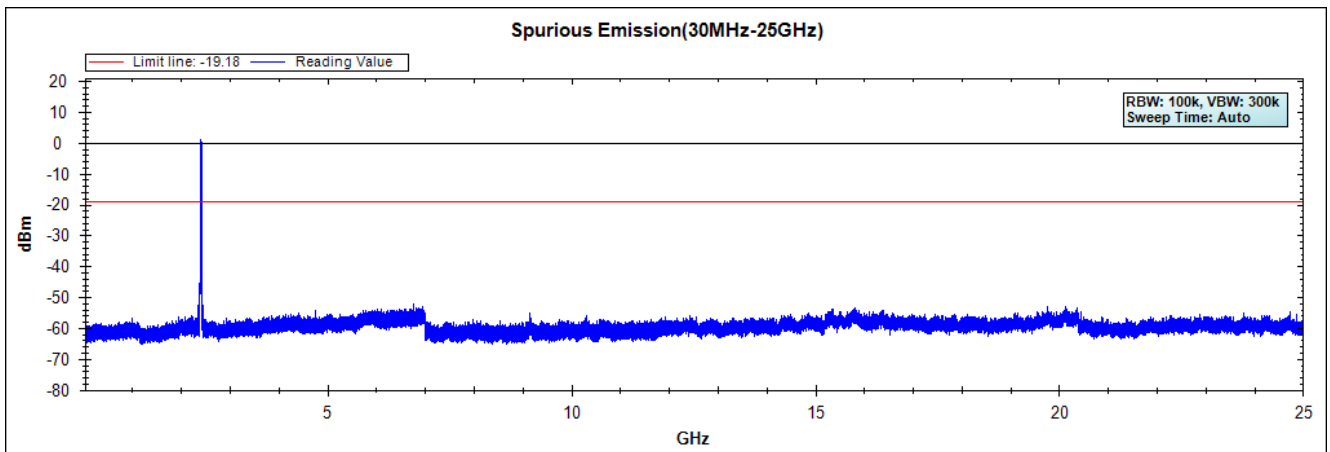

Figure Channel 01 (Chain B1)

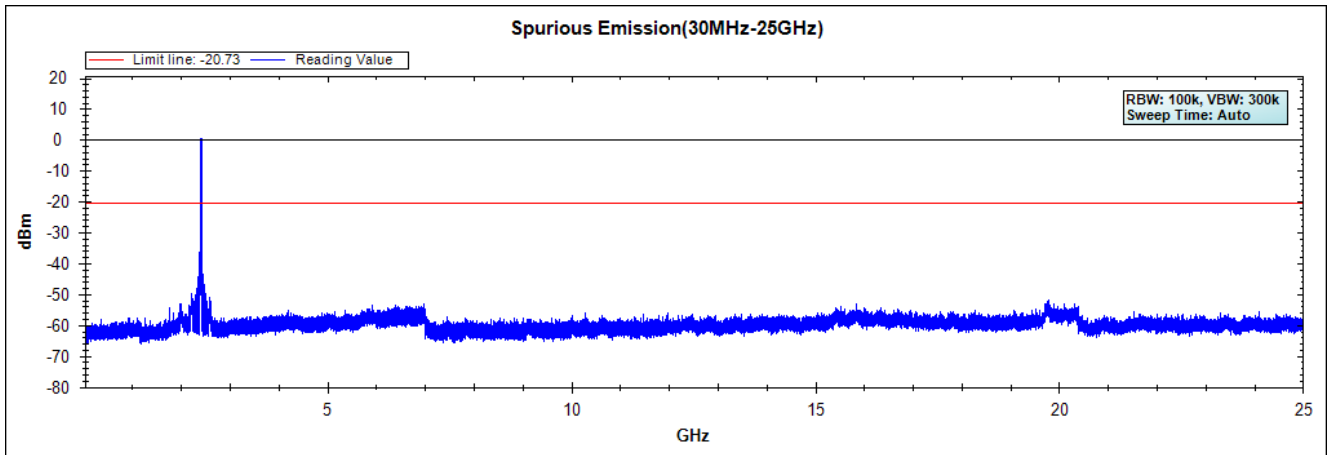

Figure Channel 01 (Chain B2)

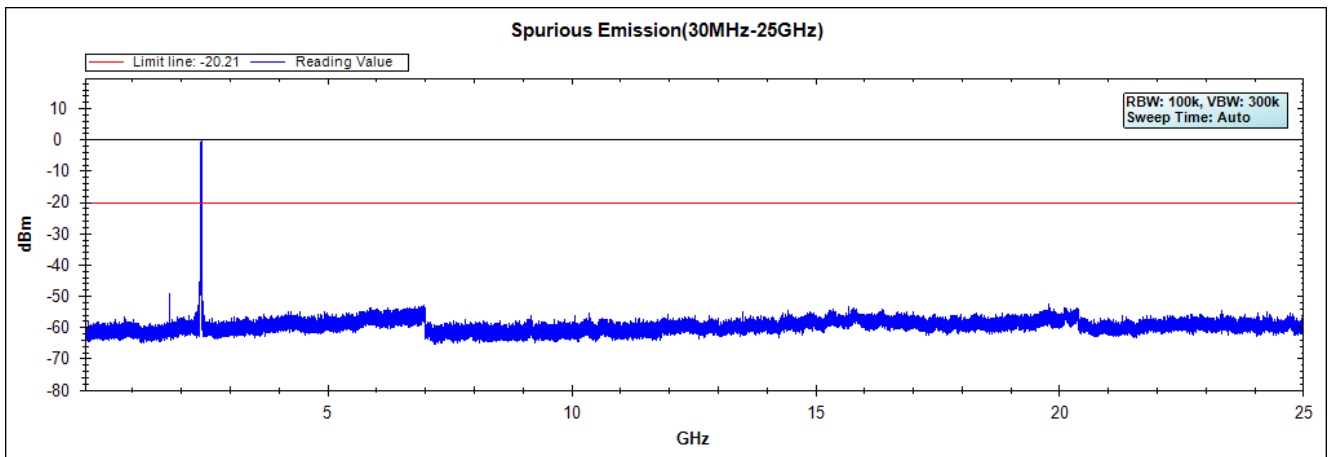

Figure Channel 06 (Chain A1)

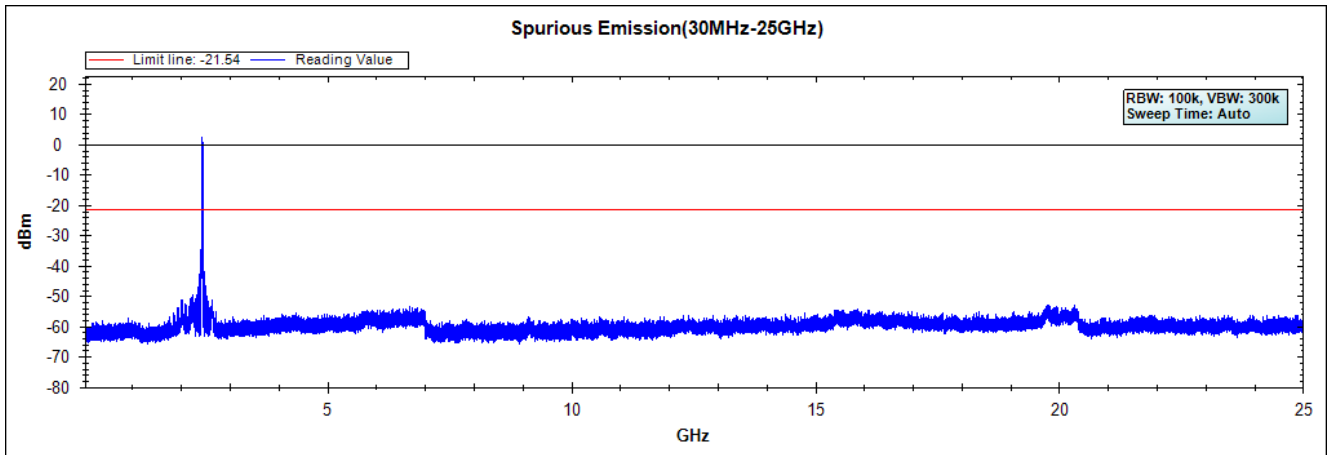

Figure Channel 06 (Chain A2)

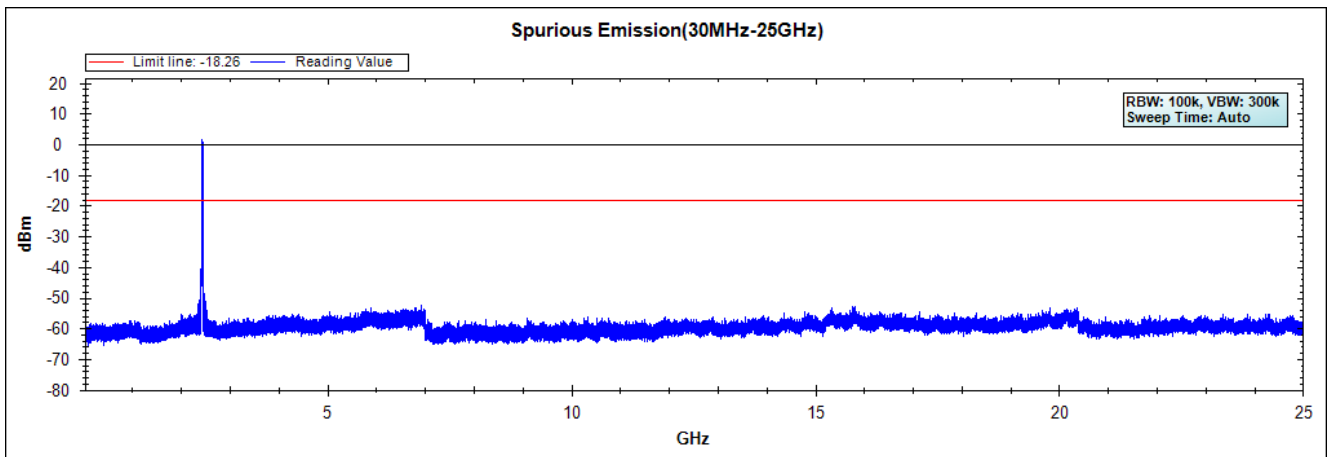

Figure Channel 06 (Chain B1)

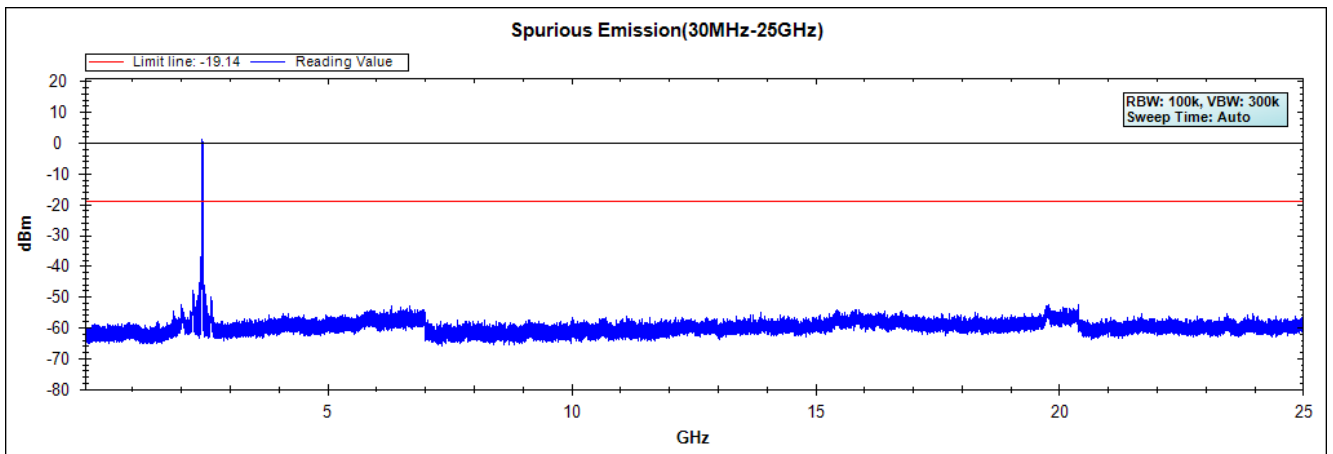

Figure Channel 06 (Chain B2)

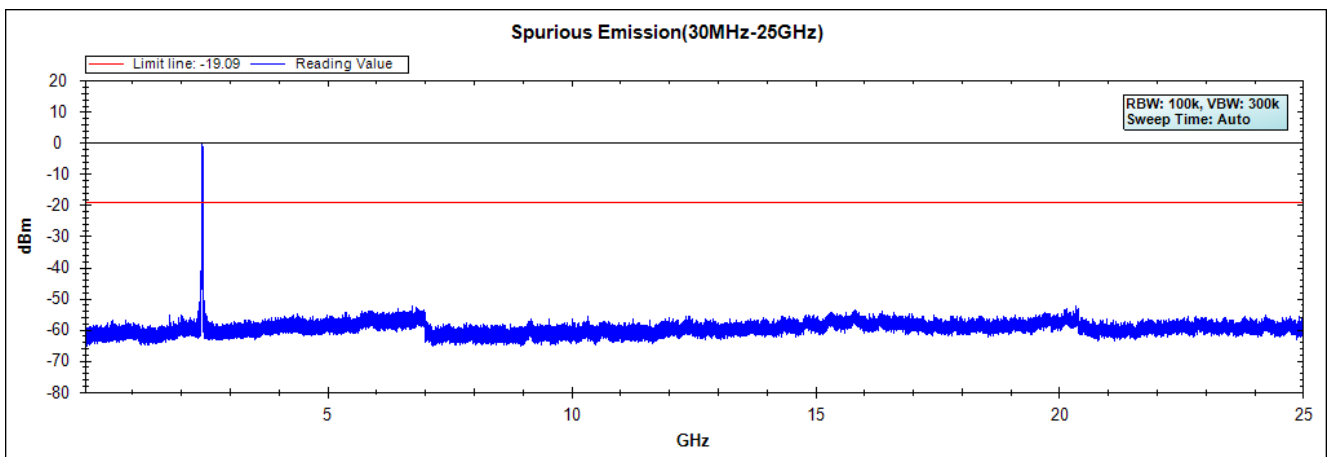

Figure Channel 11 (Chain A1)

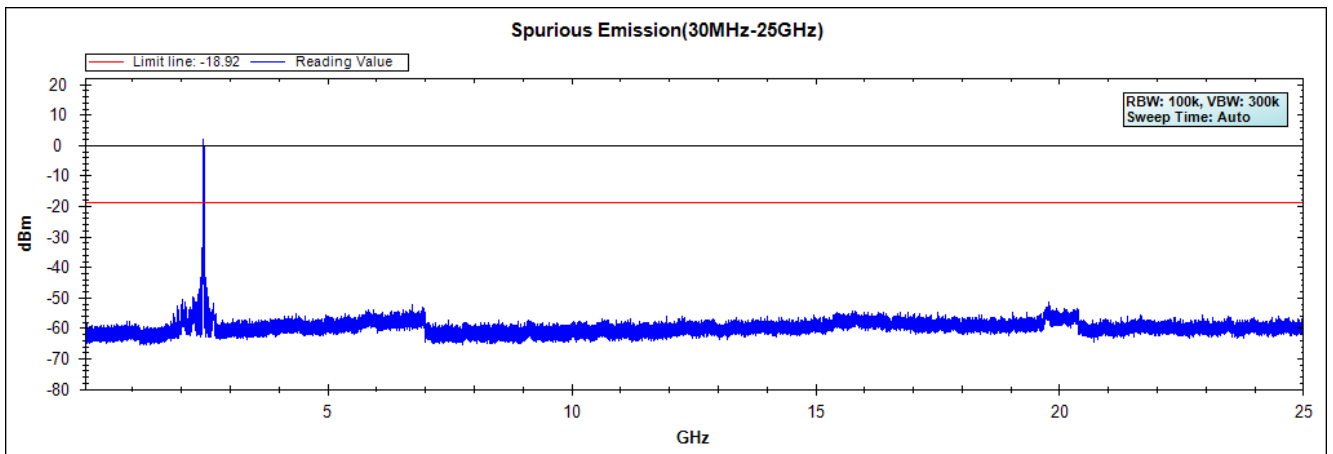

Figure Channel 11 (Chain A2)

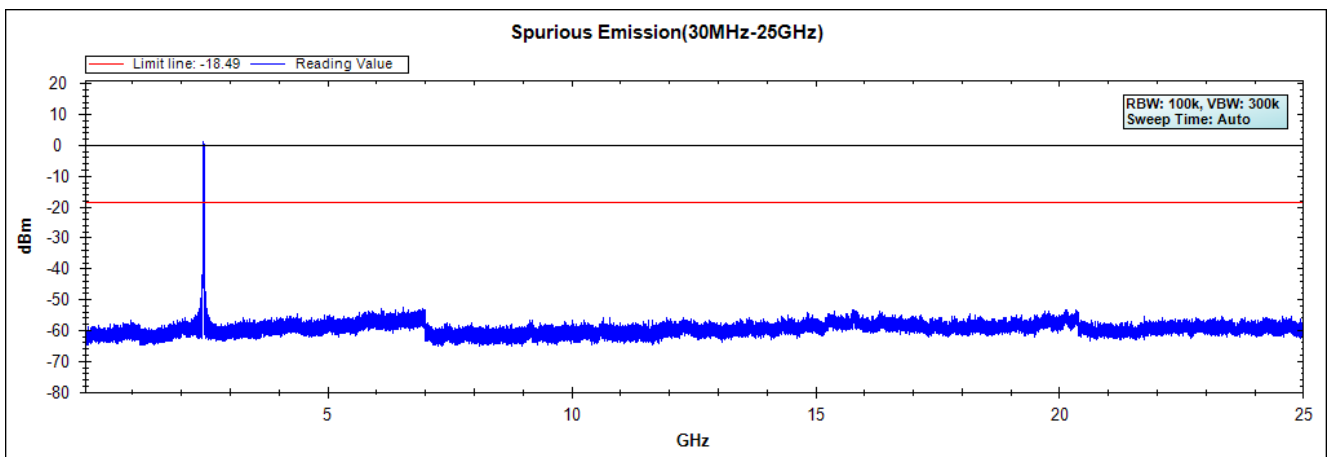

Figure Channel 11 (Chain B1)

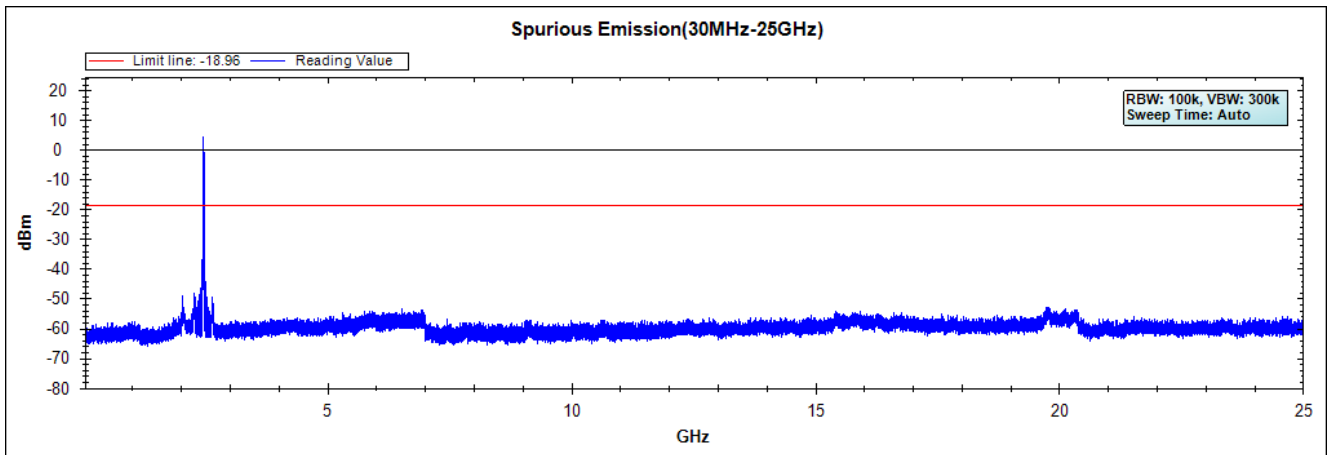
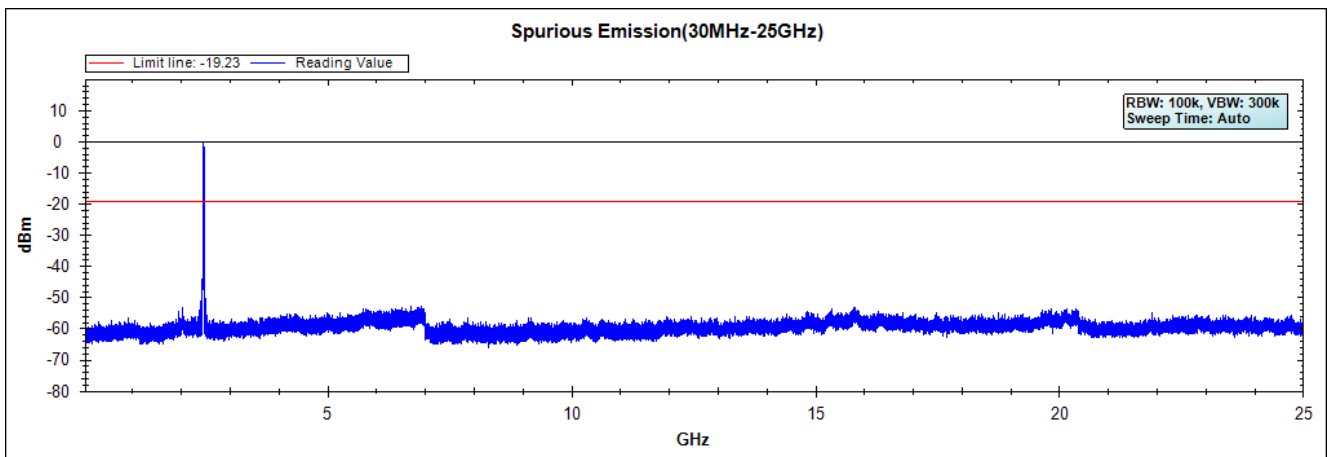

Figure Channel 11 (Chain B2)



Note: The above test pattern is synthesized by multiple of the frequency range.

Product : Software defined radio
Test Item : RF Antenna Conducted Test
Test Mode : Mode 1: Transmit_Dipole (B1+ B2)
Test Date : 2018/12/07

Figure Channel 01 (Chain B1)

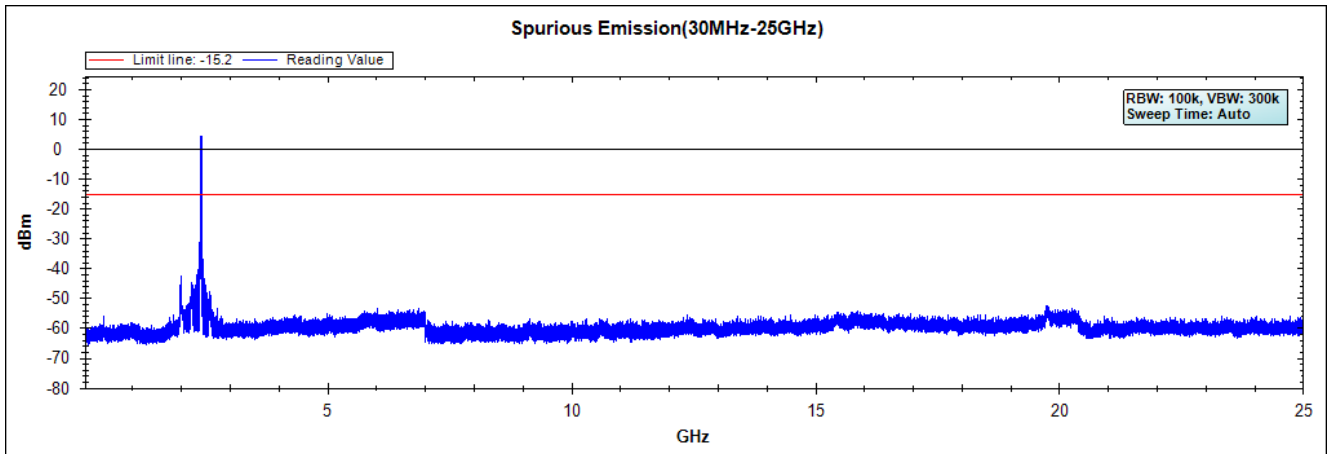

Figure Channel 01 (Chain B2)

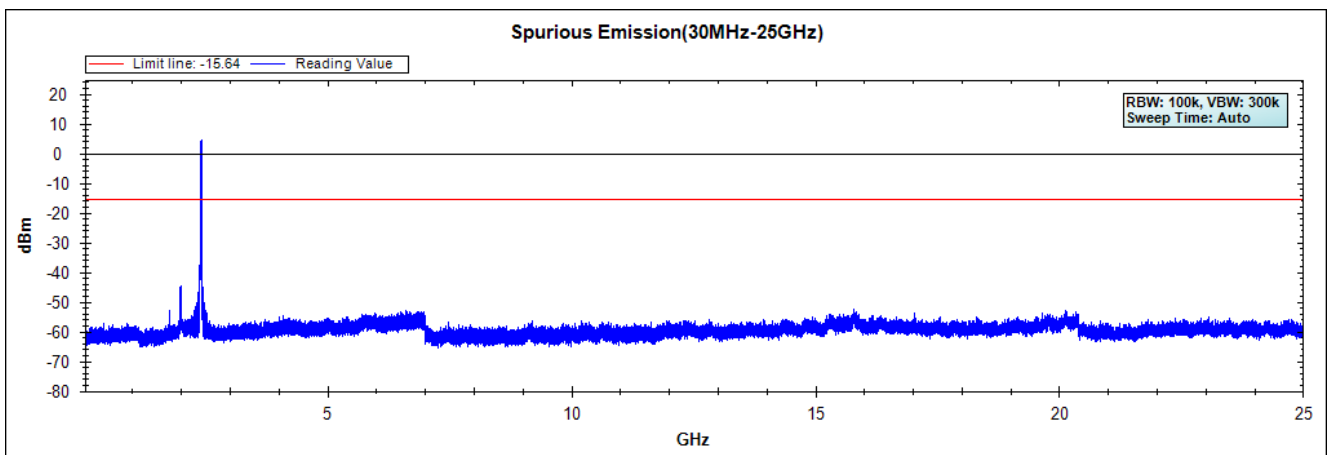

Figure Channel 06 (Chain B1)

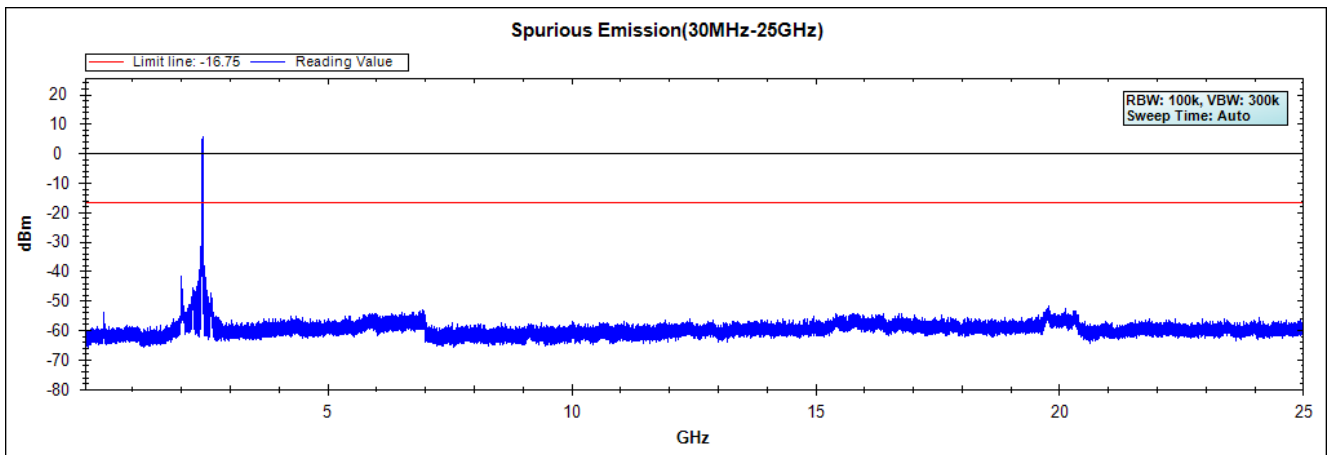

Figure Channel 06 (Chain B2)

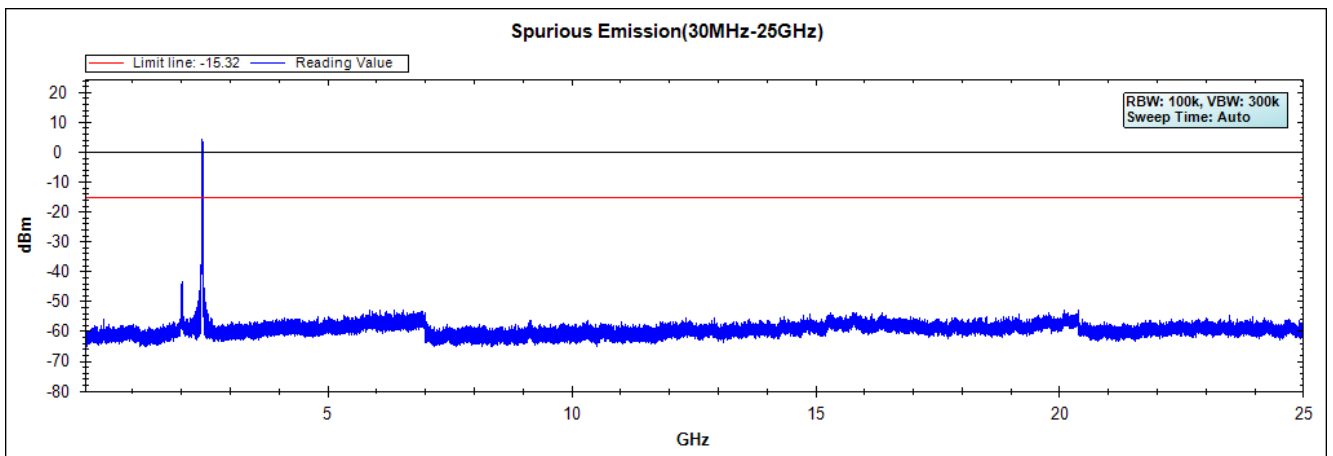

Figure Channel 11 (Chain B1)

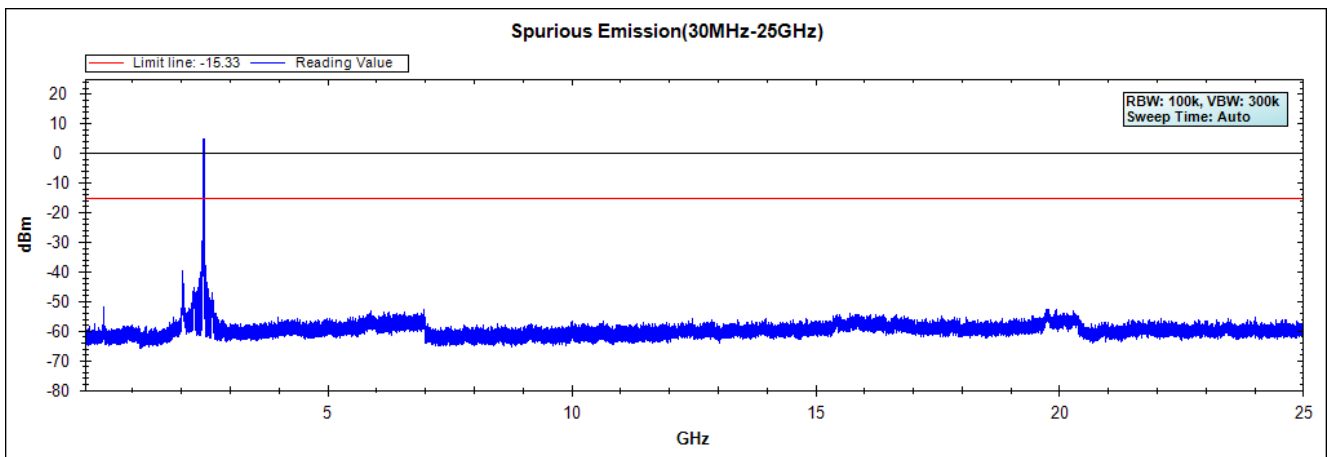
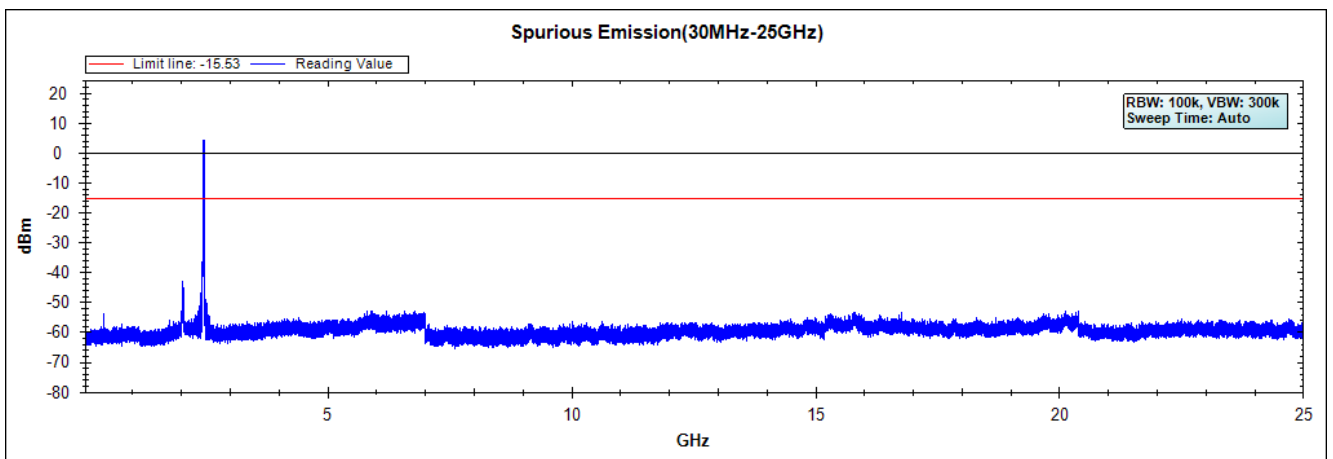

Figure Channel 11 (Chain B2)



Note: The above test pattern is synthesized by multiple of the frequency range.

Product : Software defined radio
Test Item : RF Antenna Conducted Test
Test Mode : Mode 2: Transmit_Patch (A1+ A2)
Test Date : 2018/12/07

Figure Channel 01 (Chain A1)

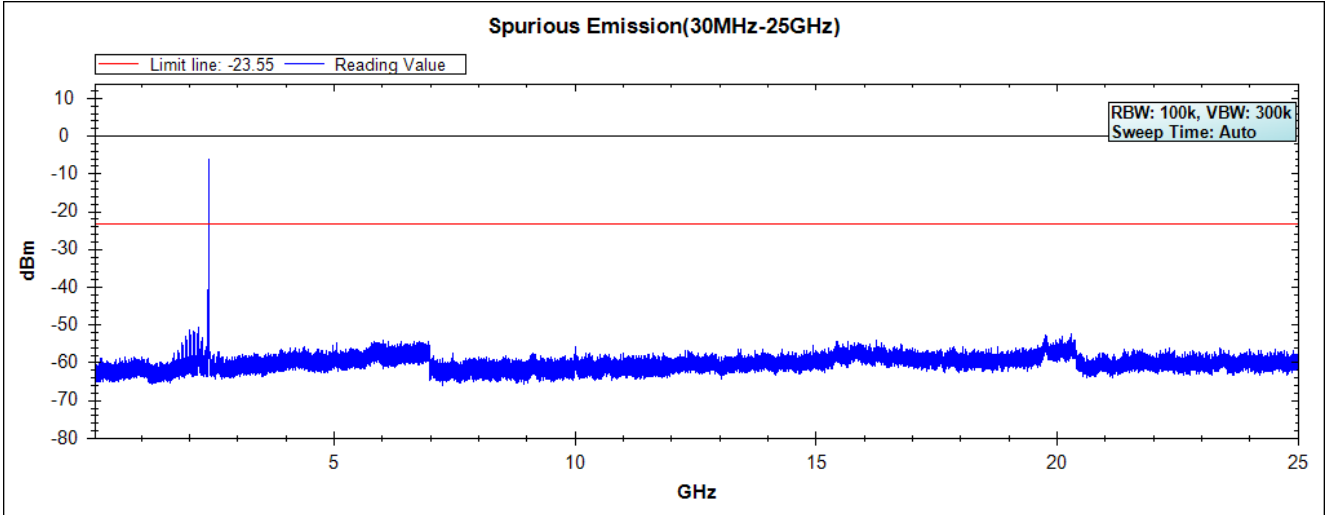

Figure Channel 01 (Chain A2)

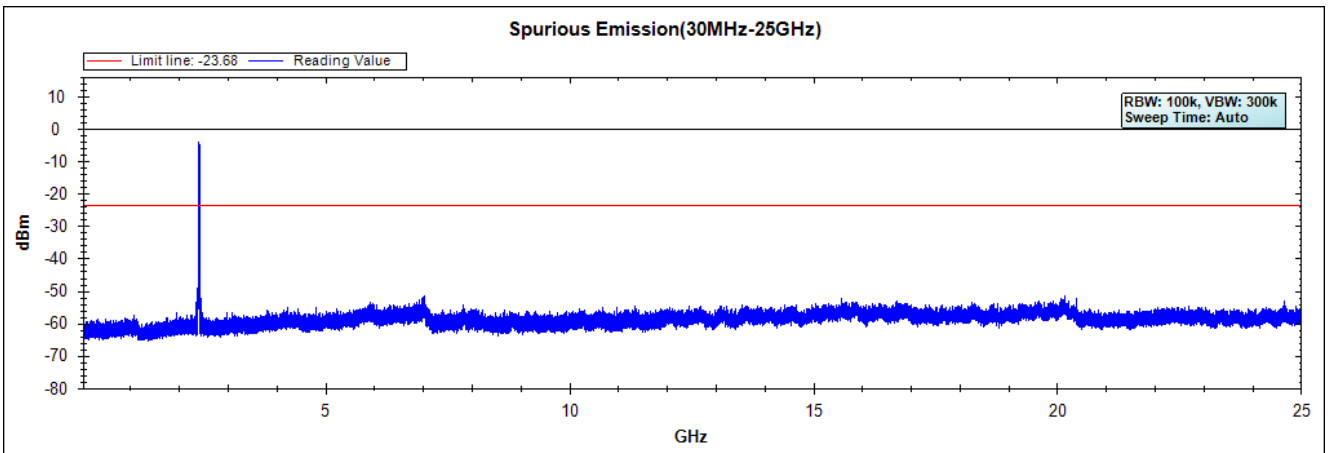

Figure Channel 06 (Chain A1)

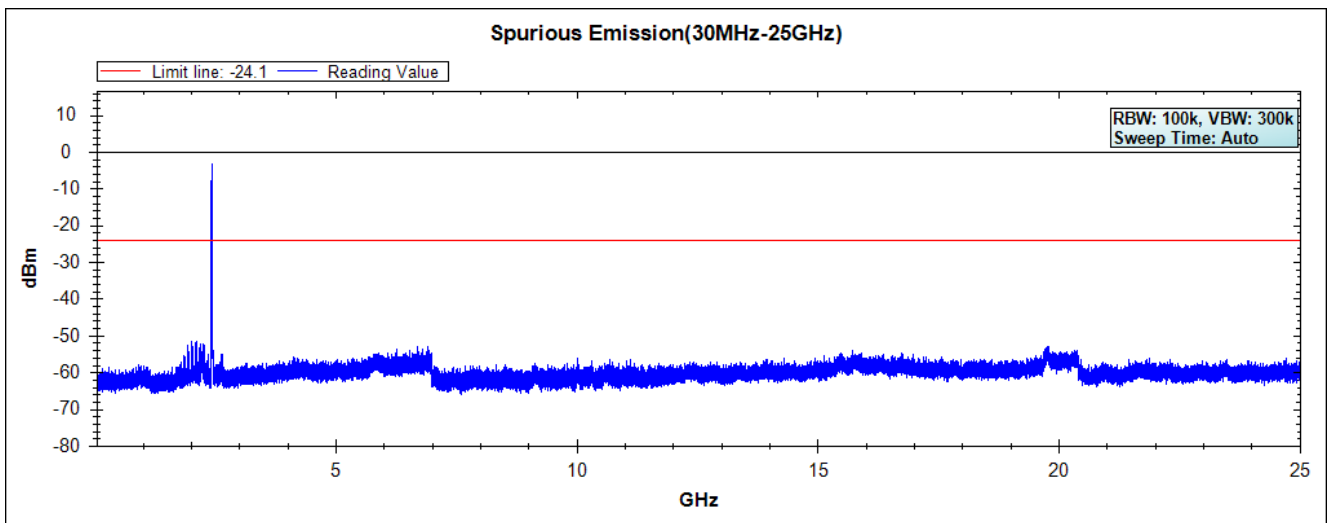

Figure Channel 06 (Chain A2)

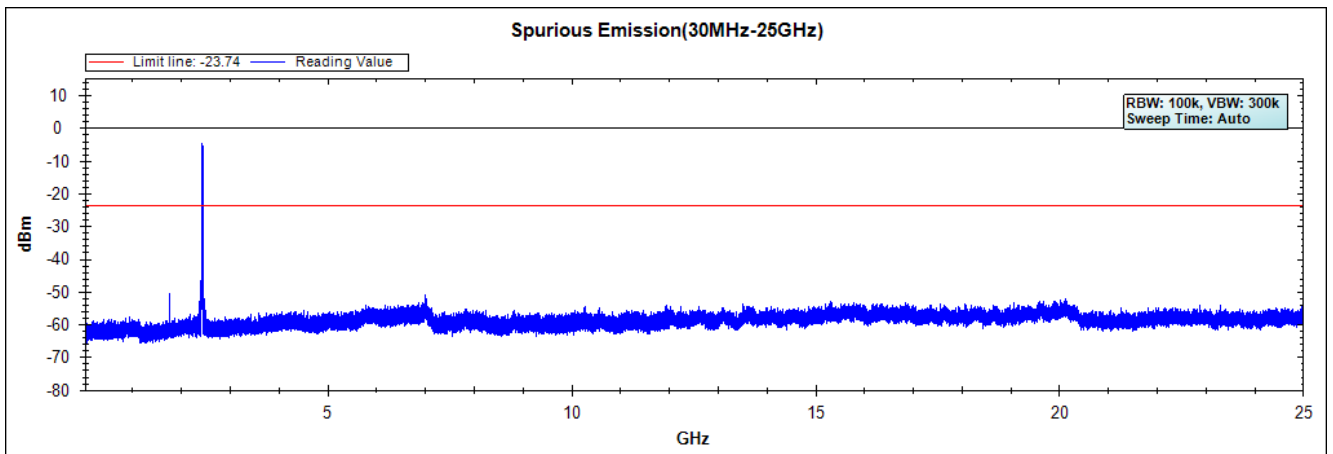

Figure Channel 11 (Chain A1)

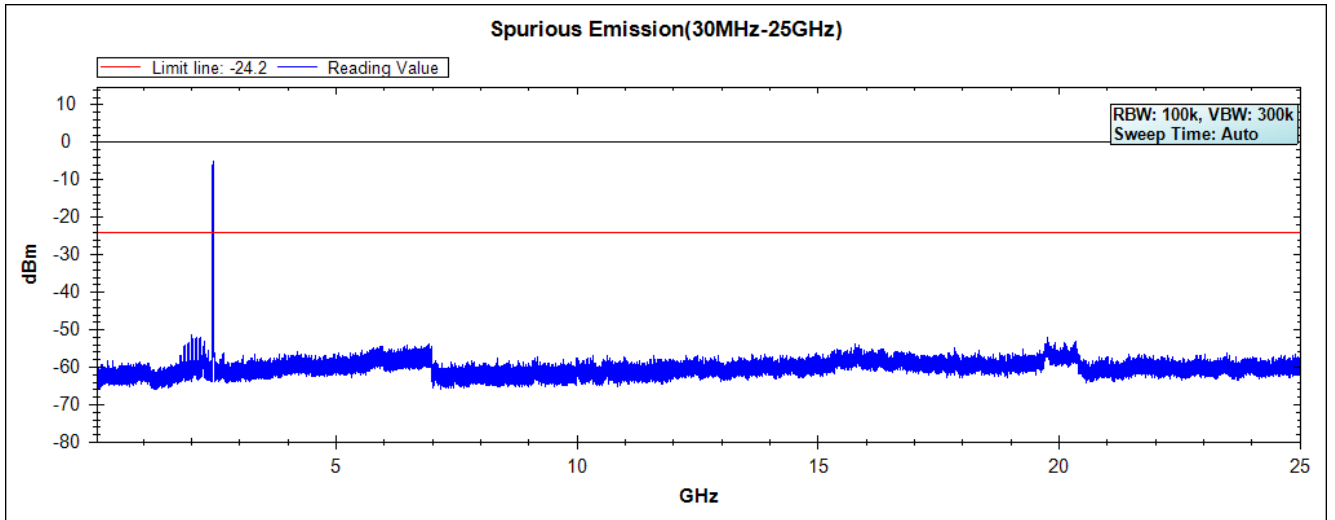
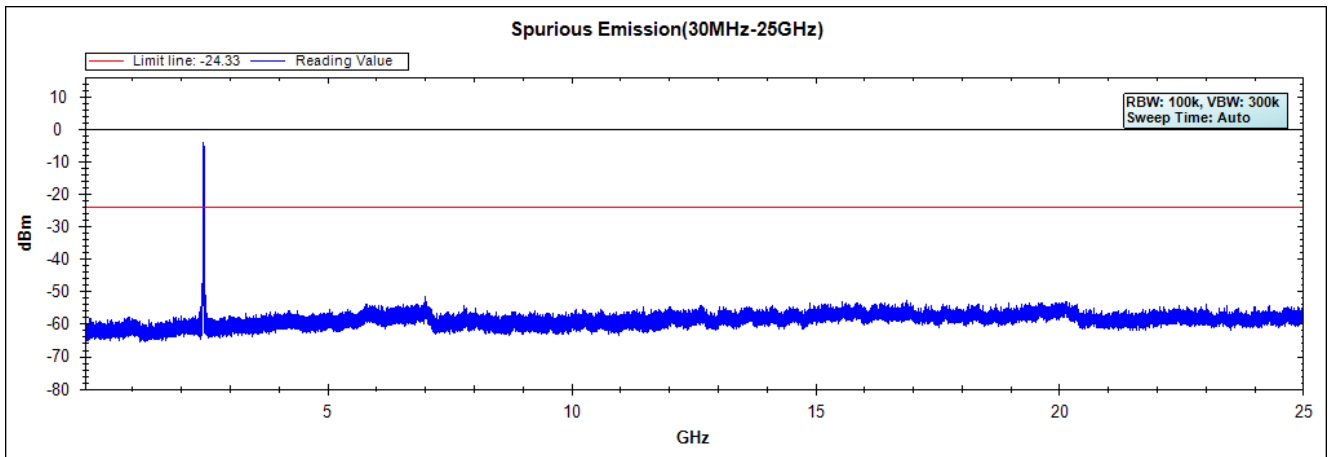

Figure Channel 11 (Chain A2)



Note: The above test pattern is synthesized by multiple of the frequency range.

Product : Software defined radio
Test Item : RF Antenna Conducted Test
Test Mode : Mode 2: Transmit_Patch (A1+ A2+ B1+ B2)
Test Date : 2019/02/27

Figure Channel 01 (Chain A1)

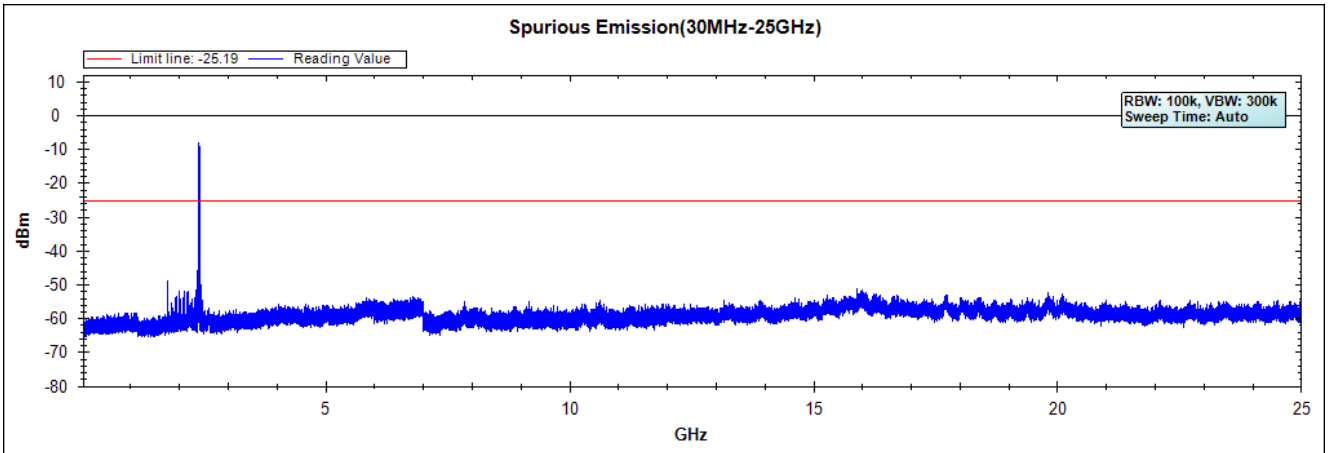

Figure Channel 01 (Chain A2)

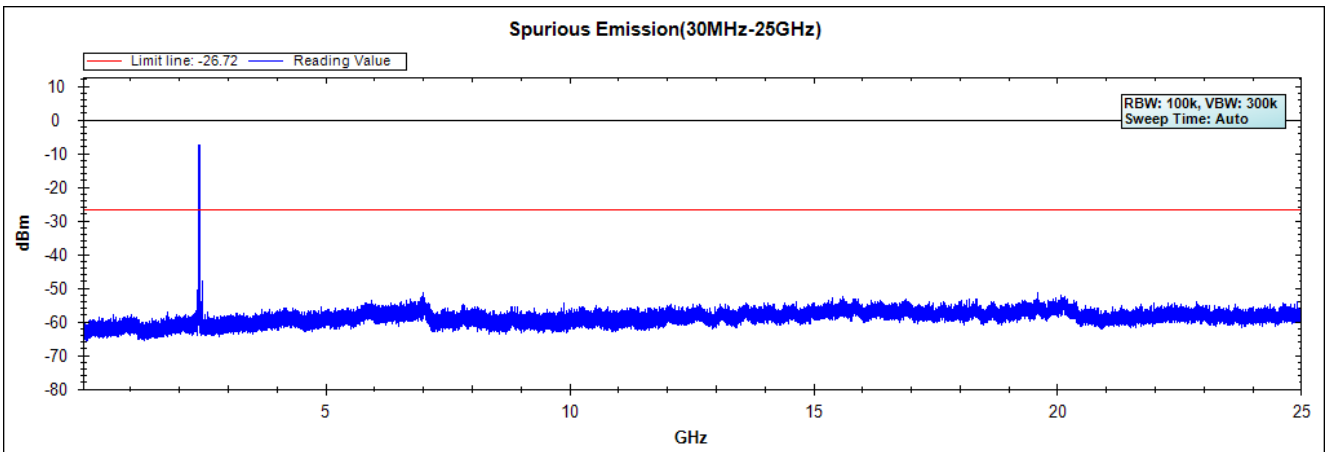

Figure Channel 01 (Chain B1)

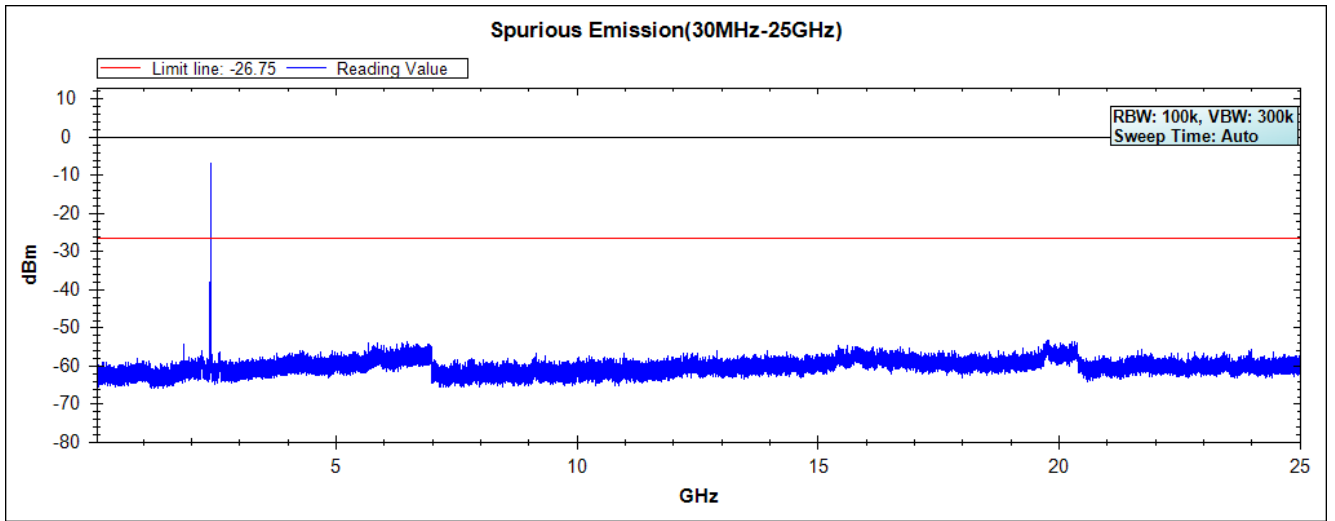

Figure Channel 01 (Chain B2)

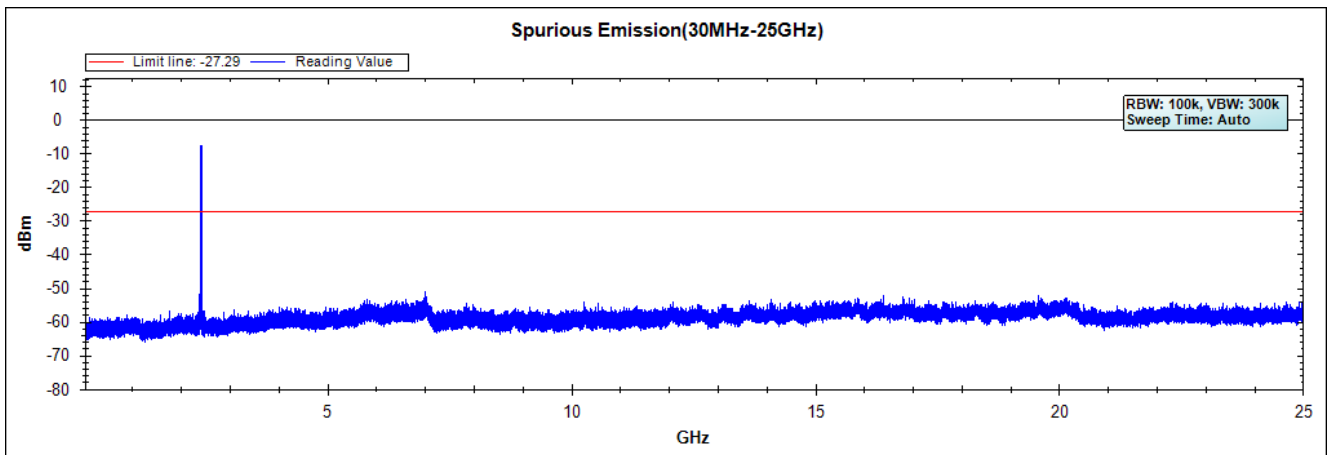

Figure Channel 06 (Chain A1)

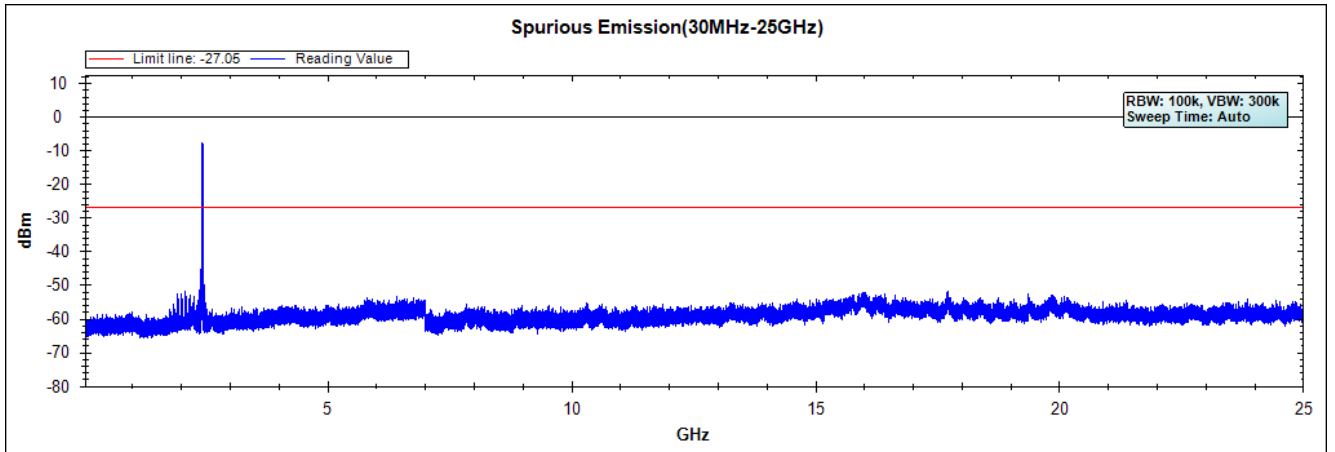

Figure Channel 06 (Chain A2)

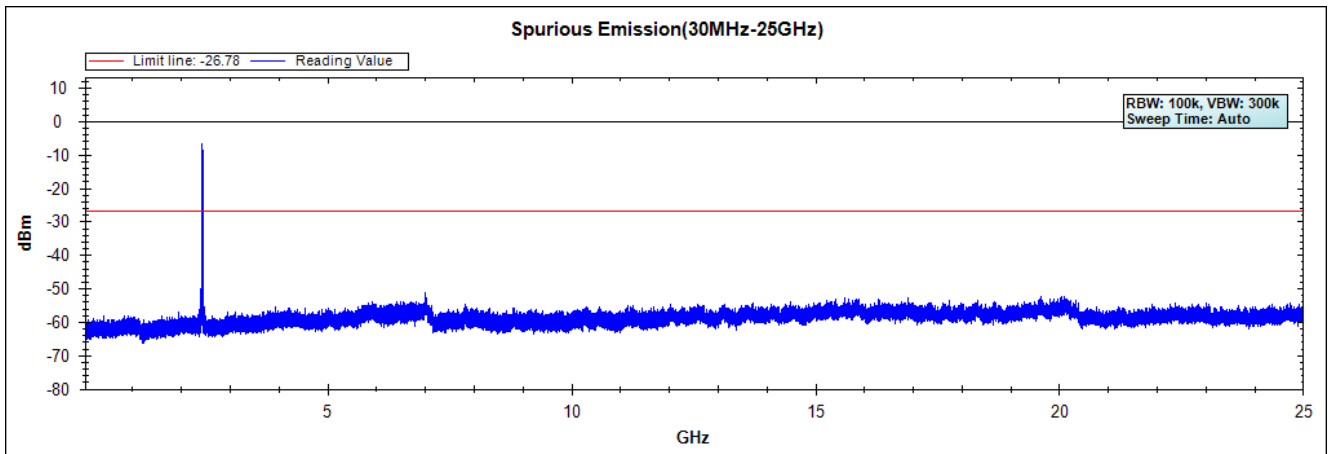

Figure Channel 06 (Chain B1)

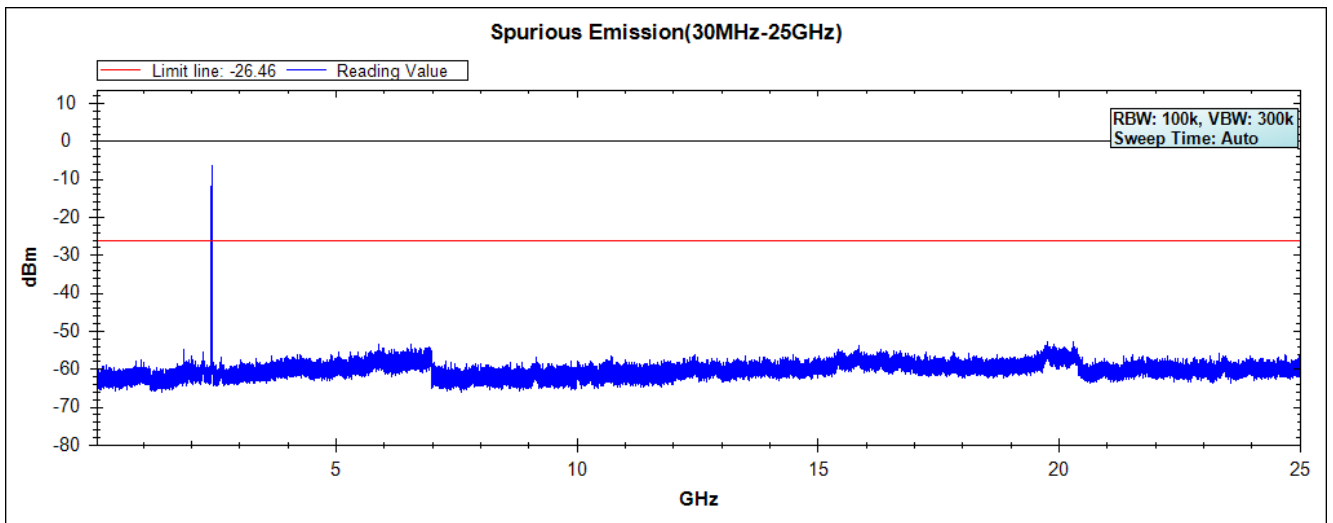

Figure Channel 06 (Chain B2)

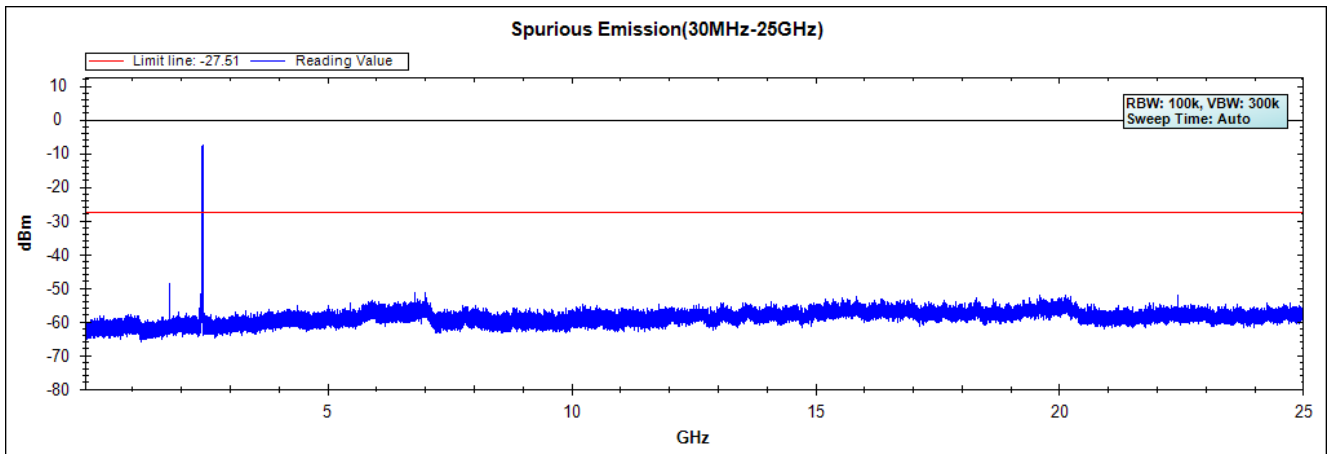

Figure Channel 11 (Chain A1)

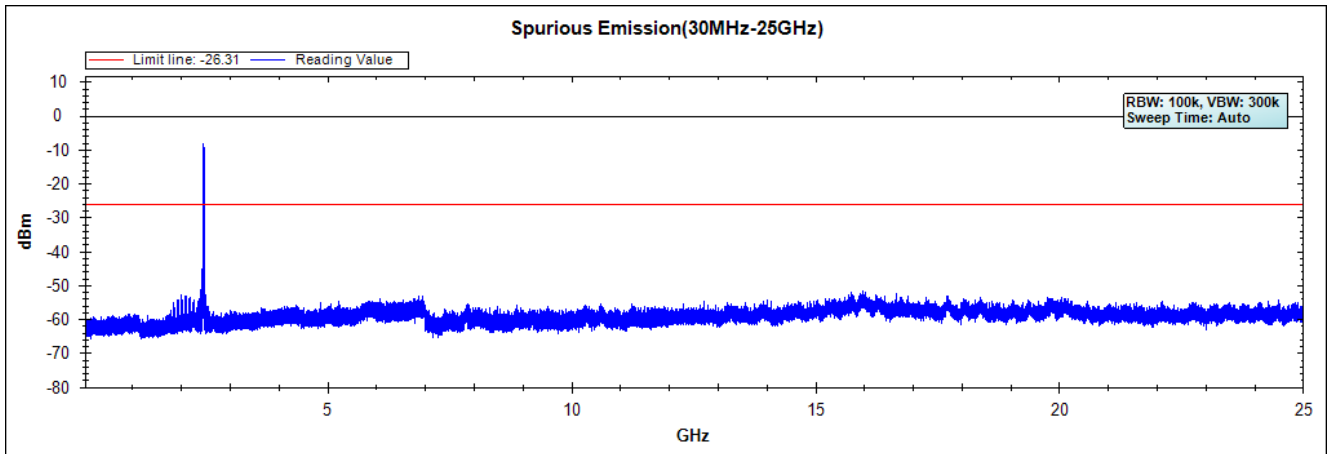

Figure Channel 11 (Chain A2)

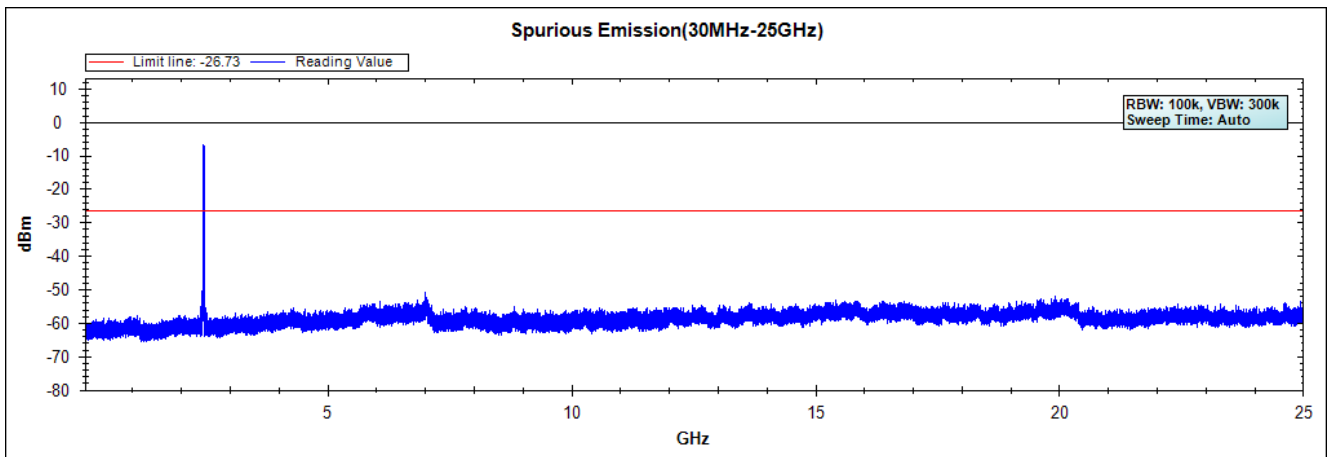

Figure Channel 11 (Chain B1)

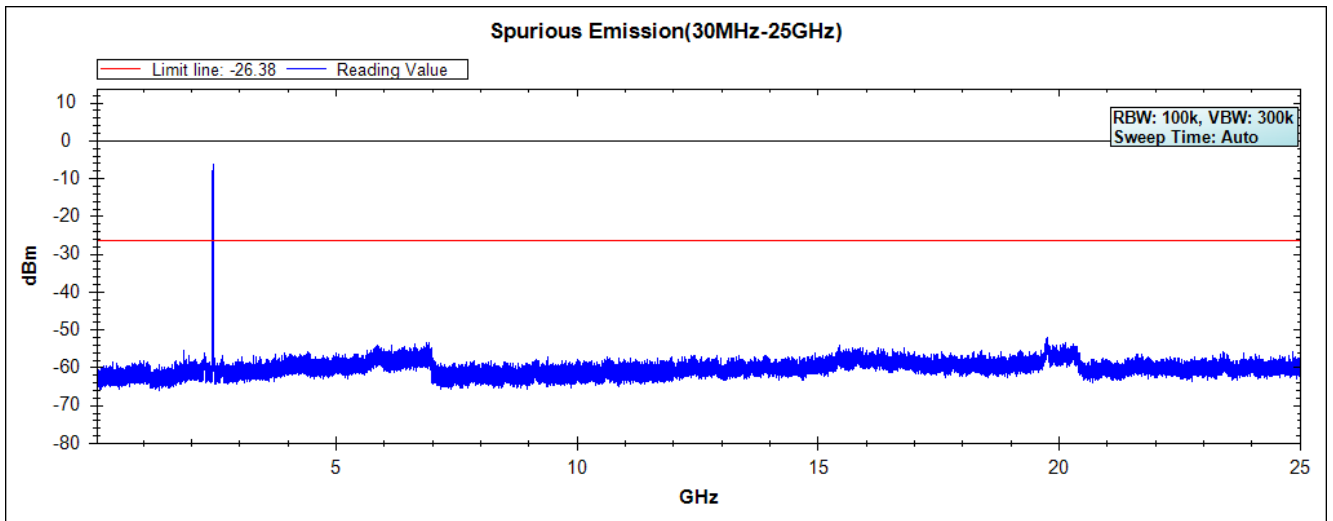
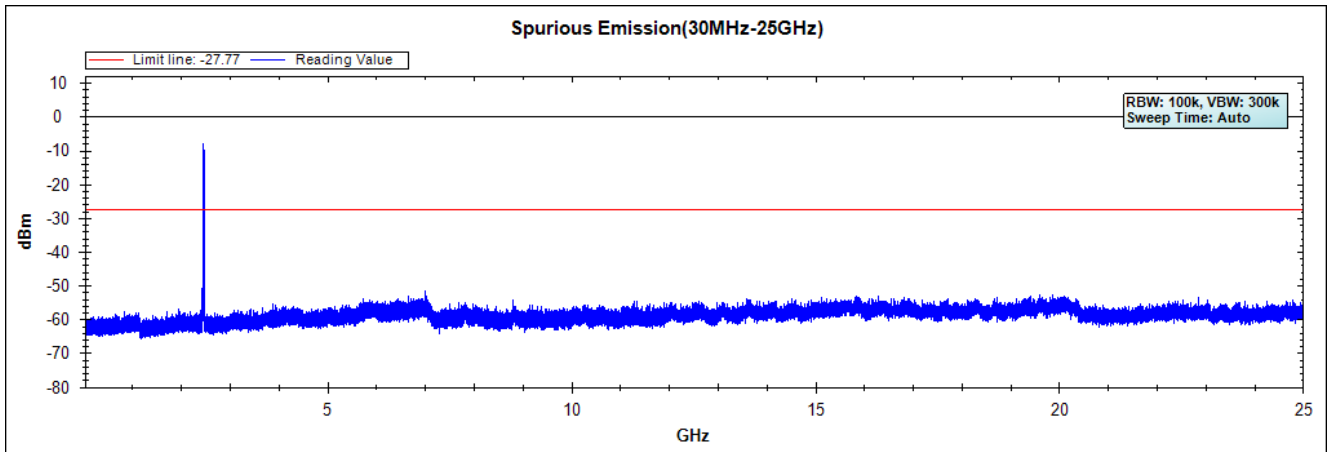

Figure Channel 11 (Chain B2)



Note: The above test pattern is synthesized by multiple of the frequency range.

Product : Software defined radio
Test Item : RF Antenna Conducted Test
Test Mode : Mode 2: Transmit_Patch (B1+ B2)
Test Date : 2019/02/27

Figure Channel 01 (Chain B1)

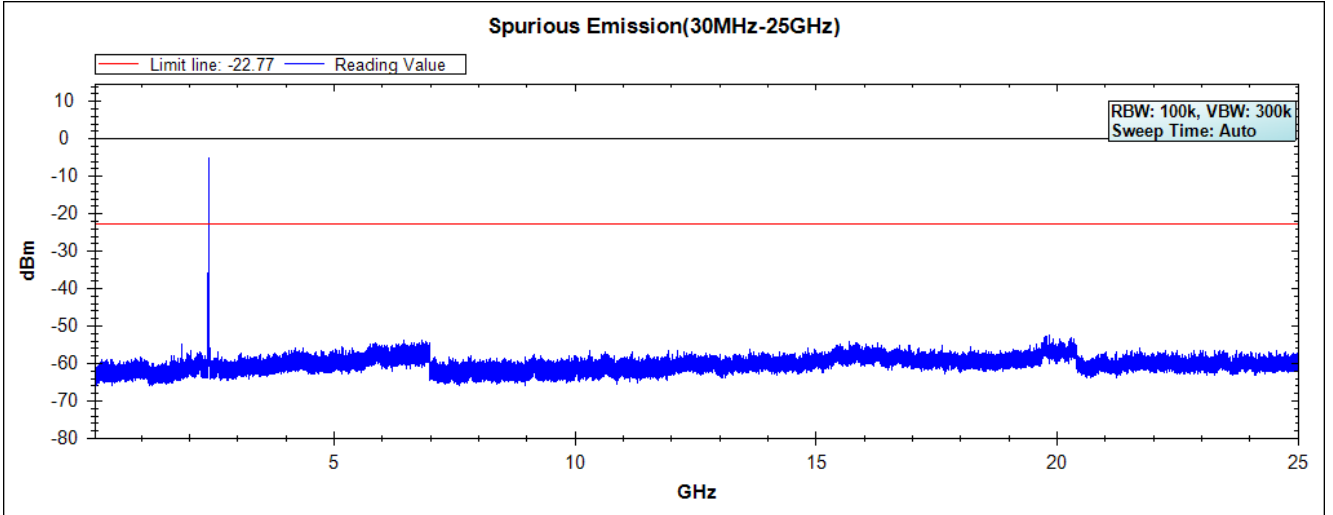

Figure Channel 01 (Chain B2)

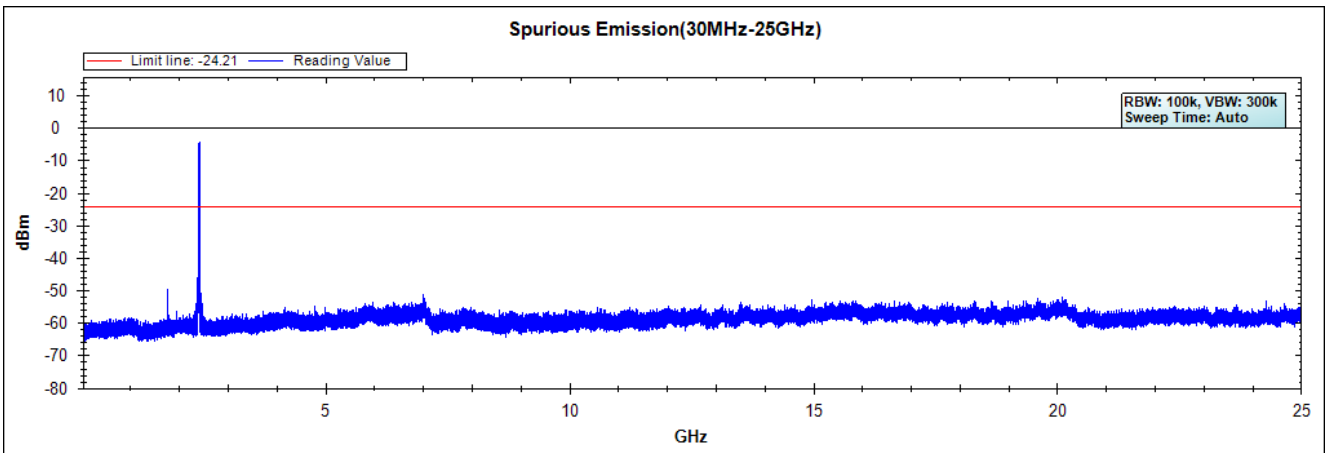

Figure Channel 06 (Chain B1)

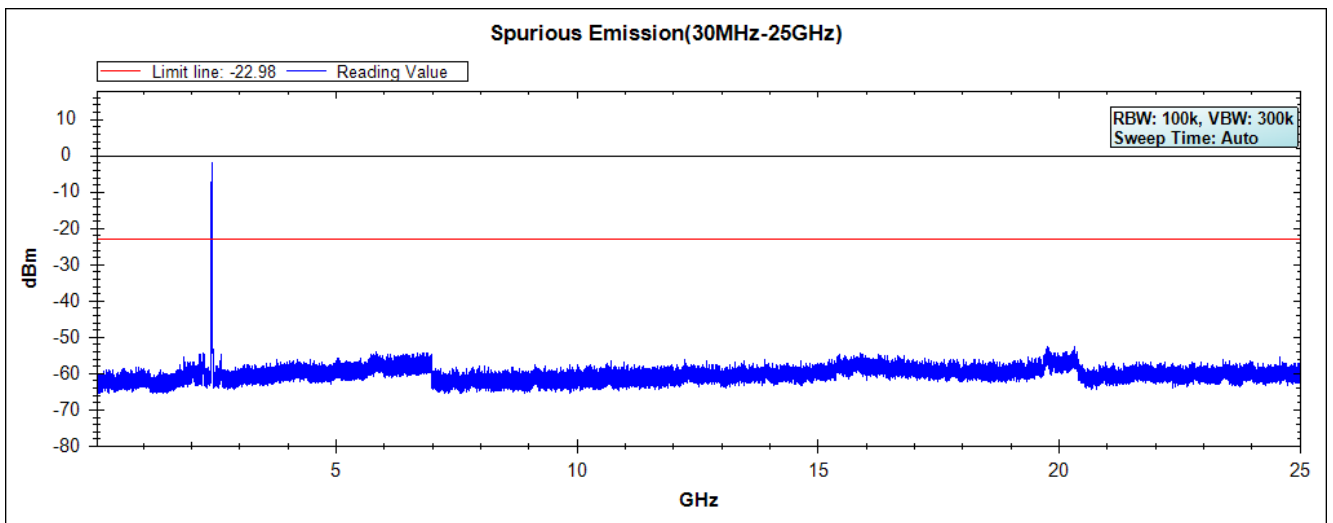

Figure Channel 06 (Chain B2)

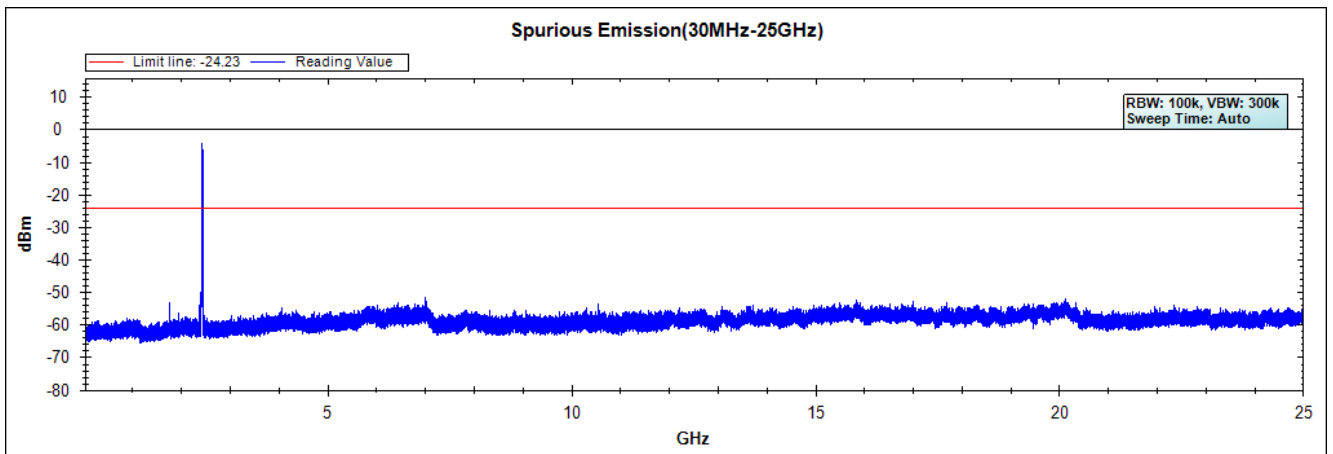

Figure Channel 11 (Chain B1)

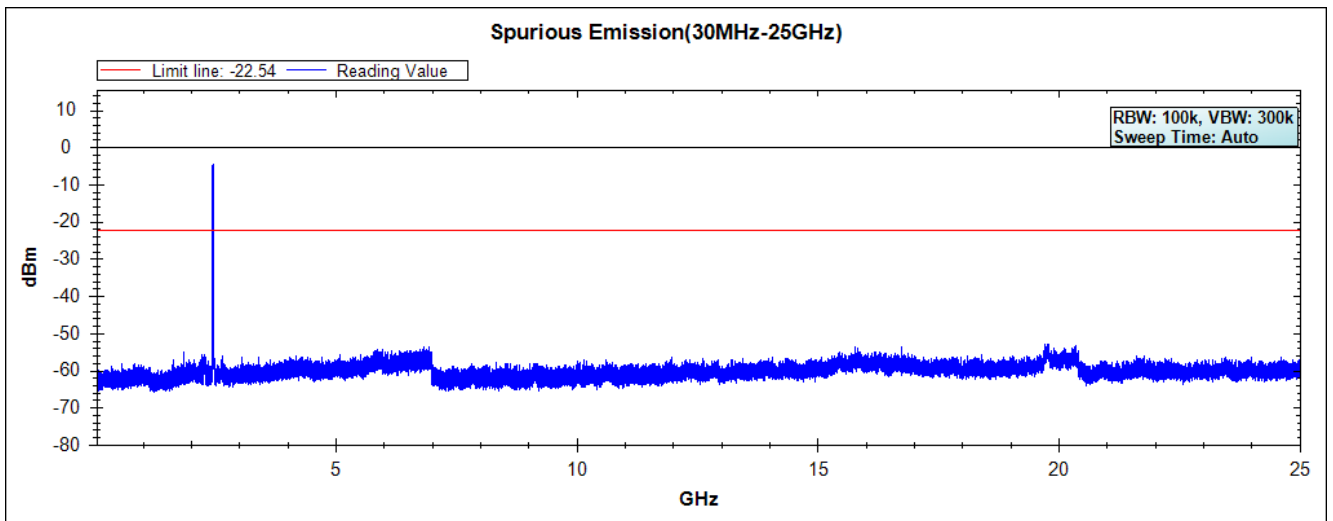
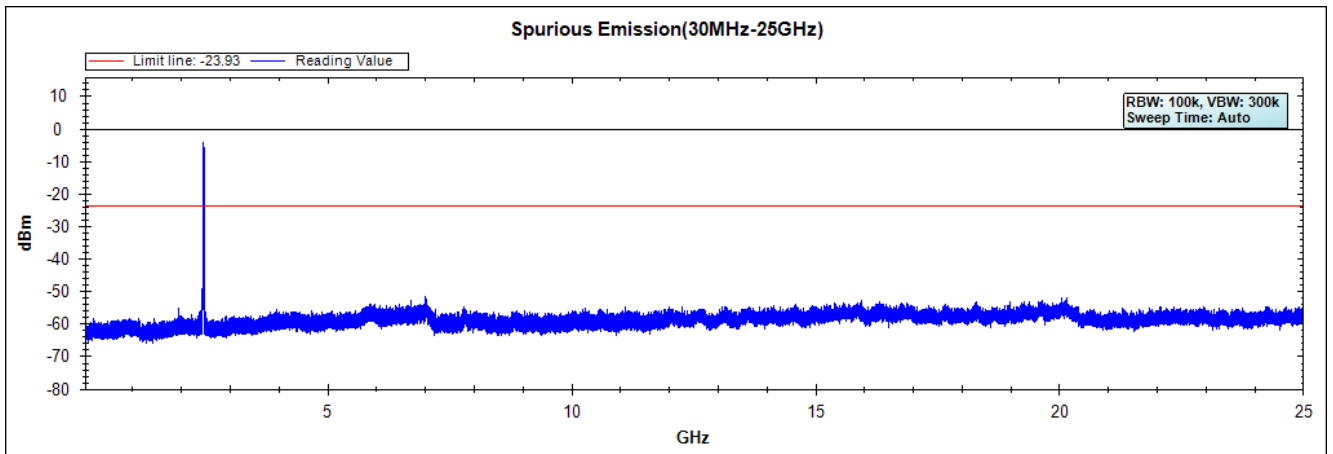

Figure Channel 11 (Chain B2)



Note: The above test pattern is synthesized by multiple of the frequency range.

6. Band Edge

6.1. Test Setup

RF Conducted Measurement

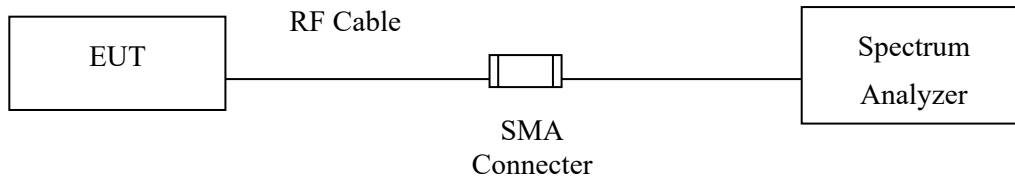

RF Radiated Measurement:

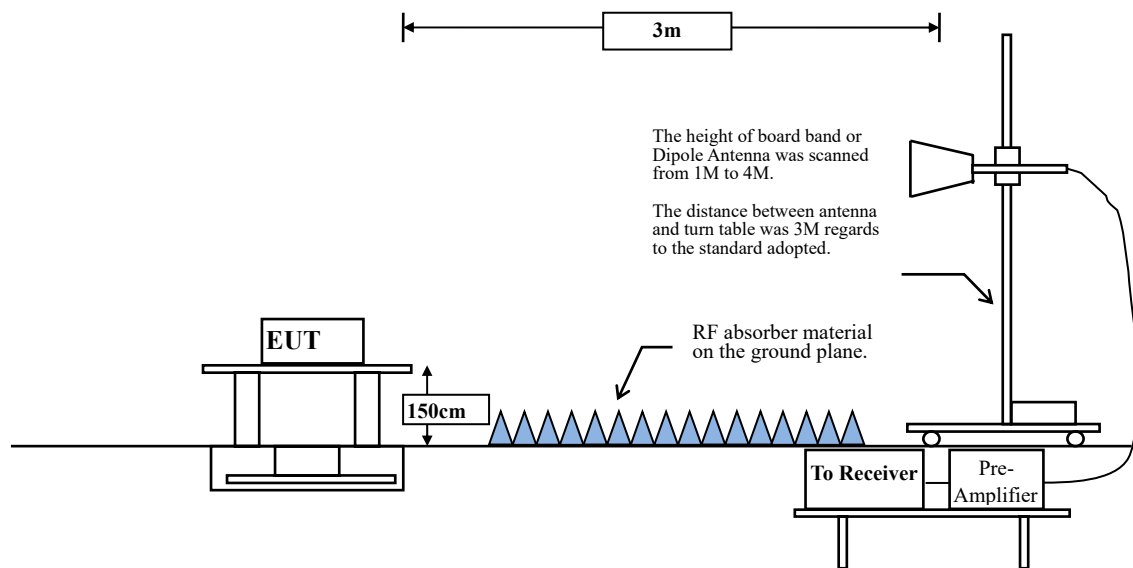

6.2. Limit

According to FCC Section 15.247(d). In any 100 kHz bandwidth outside the frequency band in which the spread spectrum or digitally modulated intentional radiator is operating, the radio frequency power that is produced by the intentional radiator shall be at least 20 dB below that in the 100 kHz bandwidth within the band that contains the highest level of the desired power, based on either an RF conducted or measurement, provided the transmitter demonstrates compliance with the peak conducted power limits. If the transmitter complies with the conducted power limits based on the use of RMS averaging over a time interval, the attenuation required under this paragraph shall be 30 dB instead of 20 dB. Attenuation below the general limits specified in Section 15.209(a) is not required. In addition, radiated emissions which fall in the restricted bands, as defined in Section 15.205(a), must also comply with the radiated emission limits specified in Section 15.209(a) (see Section 15.205(c)).

6.3. Test Procedure

The EUT was setup according to ANSI C63.10, 2013 and tested according to DTS test procedure of KDB558074 for compliance to FCC 47CFR 15.247 requirements.

The EUT is placed on a turn table which is 1.5 meter above ground. The turn table is rotated 360 degrees to determine the position of the maximum emission level. The EUT was positioned such that the distance from antenna to the EUT was 3 meters.

The antenna is scanned from 1 meter to 4 meters to find out the maximum emission level. This is repeated for both horizontal and vertical polarization of the antenna. In order to find the maximum emission, all of the interface cables were manipulated according to ANSI C63.10:2013 on radiated measurement.

RBW and VBW Parameter setting:

According to KDB 558074 Peak power measurement procedure

RBW = as specified in Table 1.

VBW \geq 3 x RBW.

Table 1 —RBW as a function of frequency

Frequency	RBW
9-150 kHz	200-300 Hz
0.15-30 MHz	9-10 kHz
30-1000 MHz	100-120 kHz
> 1000 MHz	1 MHz

According to KDB 558074 Average power measurement procedure

RBW = 1MHz.

VBW = 10Hz, when duty cycle \geq 98 %

VBW \geq 1/T, when duty cycle < 98 %

(T refers to the minimum transmission duration over which the transmitter is on and is transmitting at its maximum power control level for the tested mode of operation.)

2.4GHz band	Duty Cycle (%)	T (ms)	1/T (Hz)	VBW (Hz)
A1, A2	100.00	311.5940	3	10
B1, B2	100.00	461.5940	2	10
A1, A2, B1, B2	100.00	479.7100	2	10

Note: Duty Cycle Refer to Section 9

6.4. Uncertainty

Conducted: \pm 1.23dB

Radiated:

Horizontal polarization : 1-18GHz: \pm 3.77dB

Vertical polarization : 1-18GHz : \pm 3.83dB

6.5. Test Result of Band Edge

Product : Software defined radio
 Test Item : Band Edge
 Test Mode : Mode 1: Transmit_Dipole (A1+ A2) (2412MHz)
 Test Date : 2018/12/12

Horizontal

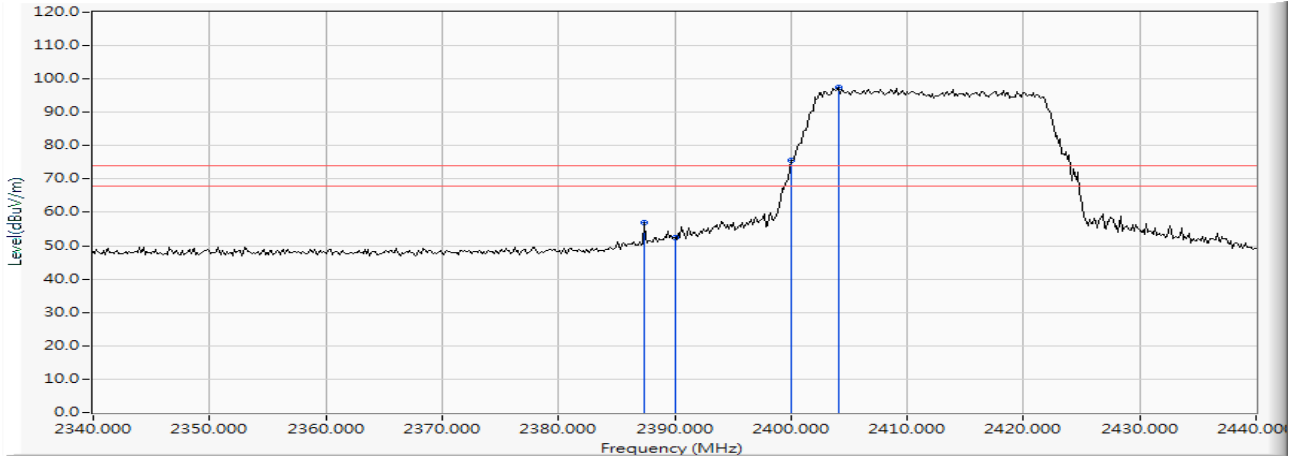

		Frequency (MHz)	Correct Factor (dB)	Reading Level (dBµV)	Measure Level (dBµV/m)	Margin (dB)	Limit (dBµV/m)	Detector Type
1		2387.391	12.174	44.655	56.828	-17.172	74.000	PEAK
2		2390.000	12.186	40.407	52.593	-21.407	74.000	PEAK
3		2400.000	12.235	63.242	75.478	--	--	PEAK
4	*	2404.058	12.248	85.276	97.523	--	--	PEAK

Note:

1. All readings above 1GHz are performed with peak and/or average measurements as necessary.
2. Measurement Level = Reading Level + Correct Factor.
3. The average measurement was not performed when the peak measured data under the limit of average detection.

Product : Software defined radio
 Test Item : Band Edge
 Test Mode : Mode 1: Transmit_Dipole (A1+ A2) (2412MHz)
 Test Date : 2017/12/12

Horizontal

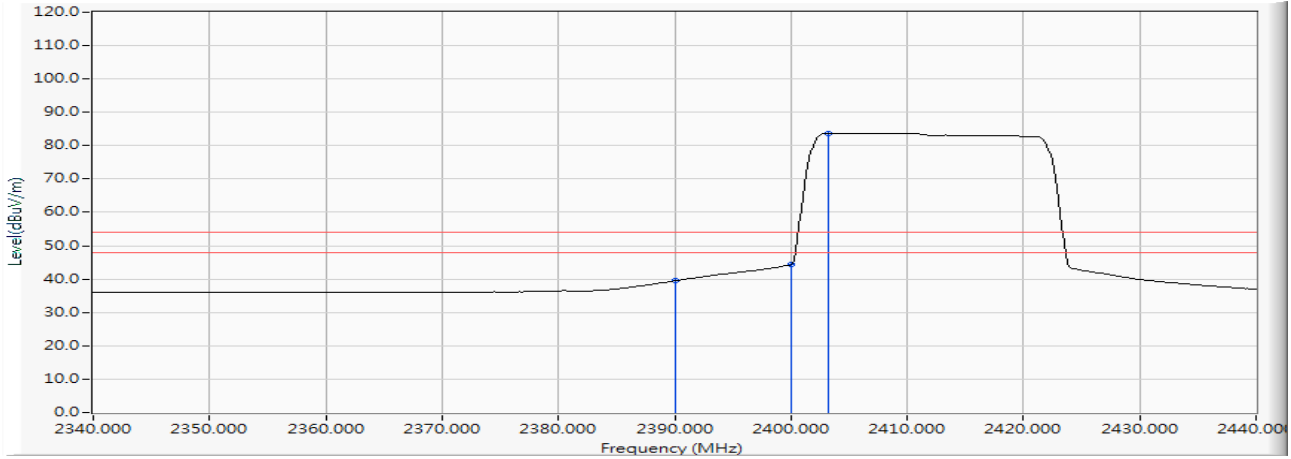

		Frequency (MHz)	Correct Factor (dB)	Reading Level (dBµV)	Measure Level (dBµV/m)	Margin (dB)	Limit (dBµV/m)	Detector Type
1		2390.000	12.186	27.262	39.448	-14.552	54.000	AVERAGE
2		2400.000	12.235	32.086	44.322	--	--	AVERAGE
3	*	2403.188	12.246	71.538	83.785	--	--	AVERAGE

Note:

1. All readings above 1GHz are performed with peak and/or average measurements as necessary.
2. Measurement Level = Reading Level + Correct Factor.
3. The average measurement was not performed when the peak measured data under the limit of average detection.

Product : Software defined radio
 Test Item : Band Edge
 Test Mode : Mode 1: Transmit_Dipole (A1+ A2) (2412MHz)
 Test Date : 2018/12/12

Vertical

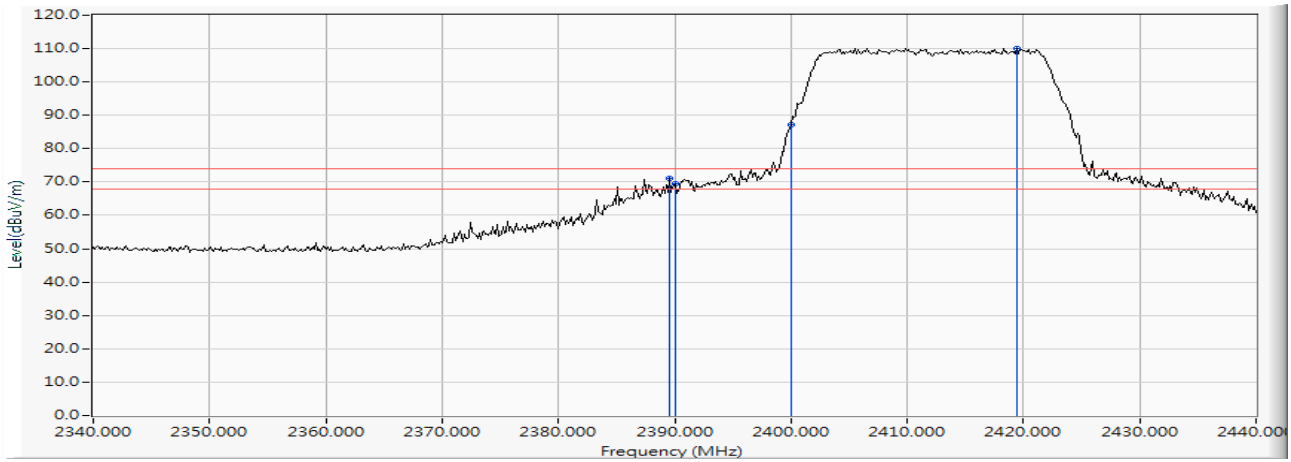

		Frequency (MHz)	Correct Factor (dB)	Reading Level (dBµV)	Measure Level (dBµV/m)	Margin (dB)	Limit (dBµV/m)	Detector Type
1		2389.565	12.184	58.959	71.143	-2.857	74.000	PEAK
2		2390.000	12.186	57.321	69.507	-4.493	74.000	PEAK
3		2400.000	12.235	74.966	87.202	--	--	PEAK
4	*	2419.420	12.263	97.897	110.160	--	--	PEAK

Note:

1. All readings above 1GHz are performed with peak and/or average measurements as necessary.
2. Measurement Level = Reading Level + Correct Factor.
3. The average measurement was not performed when the peak measured data under the limit of average detection.

Product : Software defined radio
 Test Item : Band Edge
 Test Mode : Mode 1: Transmit_Dipole (A1+ A2) (2412MHz)
 Test Date : 2018/12/12

Vertical

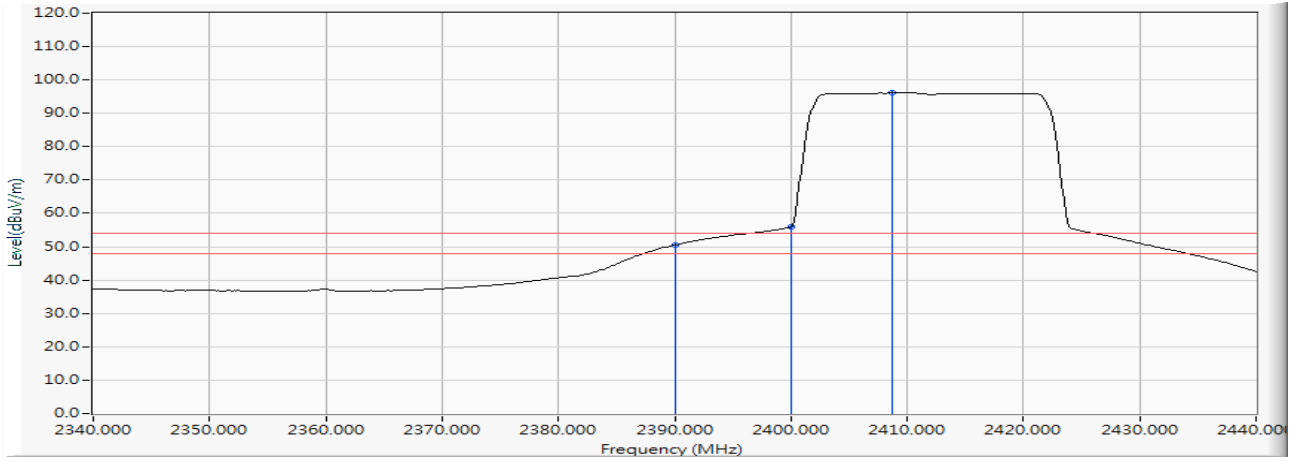

		Frequency (MHz)	Correct Factor (dB)	Reading Level (dBµV)	Measure Level (dBµV/m)	Margin (dB)	Limit (dBµV/m)	Detector Type
1		2390.000	12.186	38.334	50.520	-3.480	54.000	AVERAGE
2		2400.000	12.235	43.665	55.901	--	--	AVERAGE
3	*	2408.696	12.251	83.845	96.097	--	--	AVERAGE

Note:

1. All readings above 1GHz are performed with peak and/or average measurements as necessary.
2. Measurement Level = Reading Level + Correct Factor.
3. The average measurement was not performed when the peak measured data under the limit of average detection.

Product : Software defined radio
 Test Item : Band Edge
 Test Mode : Mode 1: Transmit_Dipole (A1+ A2) (2462MHz)
 Test Date : 2018/12/12

Horizontal

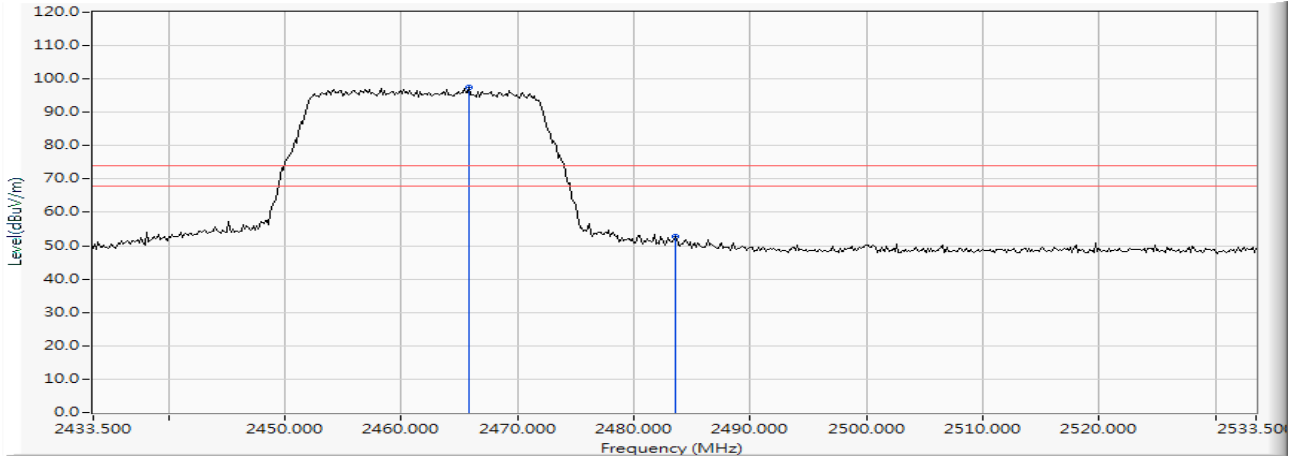

		Frequency (MHz)	Correct Factor (dB)	Reading Level (dBµV)	Measure Level (dBµV/m)	Margin (dB)	Limit (dBµV/m)	Detector Type
1	*	2465.819	12.384	85.173	97.558	--	--	PEAK
2		2483.500	12.433	40.404	52.837	-21.163	74.000	PEAK

Note:

1. All readings above 1GHz are performed with peak and/or average measurements as necessary.
2. Measurement Level = Reading Level + Correct Factor.
3. The average measurement was not performed when the peak measured data under the limit of average detection.

Product : Software defined radio
 Test Item : Band Edge
 Test Mode : Mode 1: Transmit_Dipole (A1+ A2) (2462MHz)
 Test Date : 2018/12/12

Horizontal

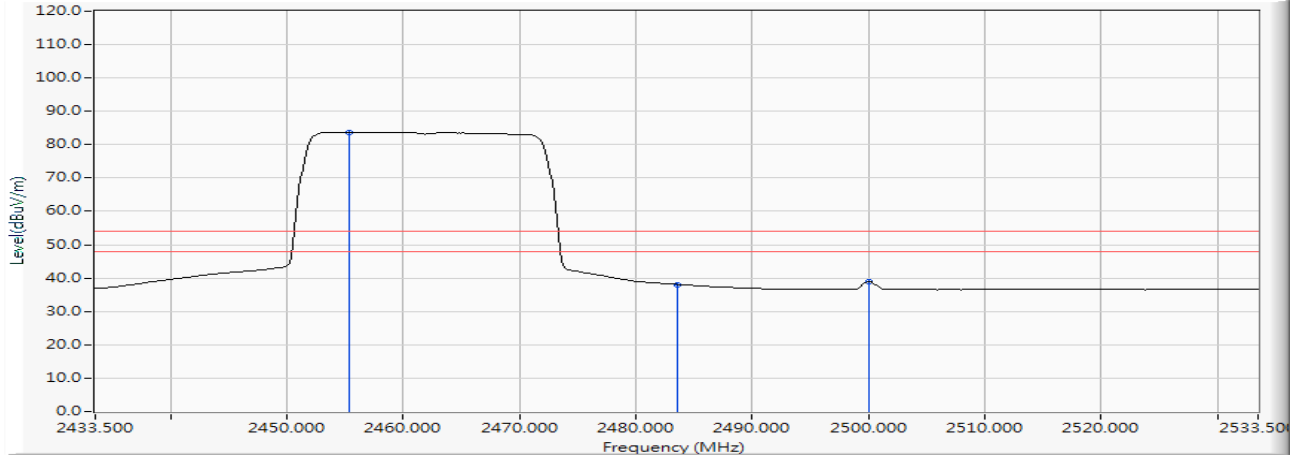

		Frequency (MHz)	Correct Factor (dB)	Reading Level (dBµV)	Measure Level (dBµV/m)	Margin (dB)	Limit (dBµV/m)	Detector Type
1	*	2455.384	12.331	71.284	83.615	--	--	AVERAGE
2		2483.500	12.433	25.671	38.104	-15.896	54.000	AVERAGE
3		2500.022	12.482	26.472	38.954	-15.046	54.000	AVERAGE

Note:

1. All readings above 1GHz are performed with peak and/or average measurements as necessary.
2. Measurement Level = Reading Level + Correct Factor.
3. The average measurement was not performed when the peak measured data under the limit of average detection.

Product : Software defined radio
 Test Item : Band Edge
 Test Mode : Mode 1: Transmit_Dipole (A1+ A2) (2462MHz)
 Test Date : 2018/12/12

Vertical

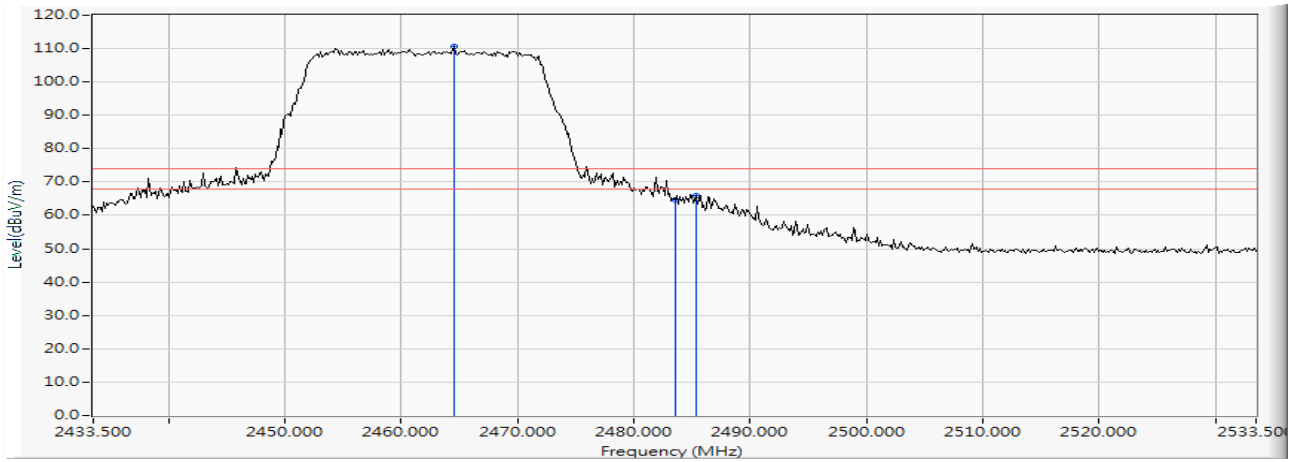

		Frequency (MHz)	Correct Factor (dB)	Reading Level (dBµV)	Measure Level (dBµV/m)	Margin (dB)	Limit (dBµV/m)	Detector Type
1	*	2464.514	12.378	98.150	110.528	--	--	PEAK
2		2483.500	12.433	52.093	64.526	-9.474	74.000	PEAK
3		2485.384	12.434	53.676	66.110	-7.890	74.000	PEAK

Note:

1. All readings above 1GHz are performed with peak and/or average measurements as necessary.
2. Measurement Level = Reading Level + Correct Factor.
3. The average measurement was not performed when the peak measured data under the limit of average detection.

Product : Software defined radio
 Test Item : Band Edge
 Test Mode : Mode 1: Transmit_Dipole (A1+ A2) (2462MHz)
 Test Date : 2018/12/12

Vertical

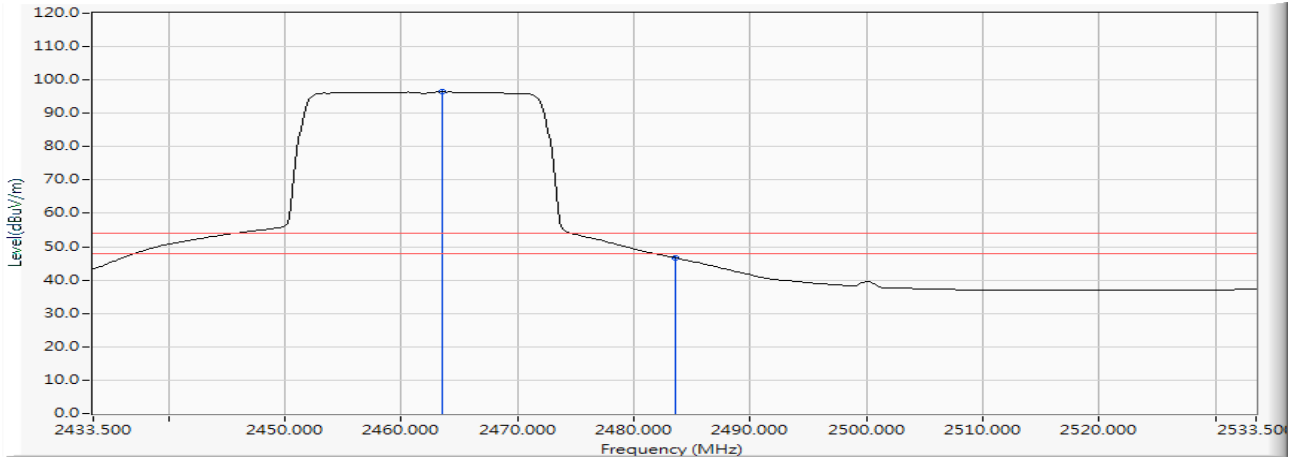

		Frequency (MHz)	Correct Factor (dB)	Reading Level (dBµV)	Measure Level (dBµV/m)	Margin (dB)	Limit (dBµV/m)	Detector Type
1	*	2463.500	12.372	84.018	96.390	--	--	AVERAGE
2		2483.500	12.433	34.296	46.729	-7.271	54.000	AVERAGE

Note:

1. All readings above 1GHz are performed with peak and/or average measurements as necessary.
2. Measurement Level = Reading Level + Correct Factor.
3. The average measurement was not performed when the peak measured data under the limit of average detection.

Product : Software defined radio
 Test Item : Band Edge
 Test Mode : Mode 1: Transmit_Dipole (A1+ A2+ B1+ B2) (2412MHz)
 Test Date : 2018/12/12

Horizontal

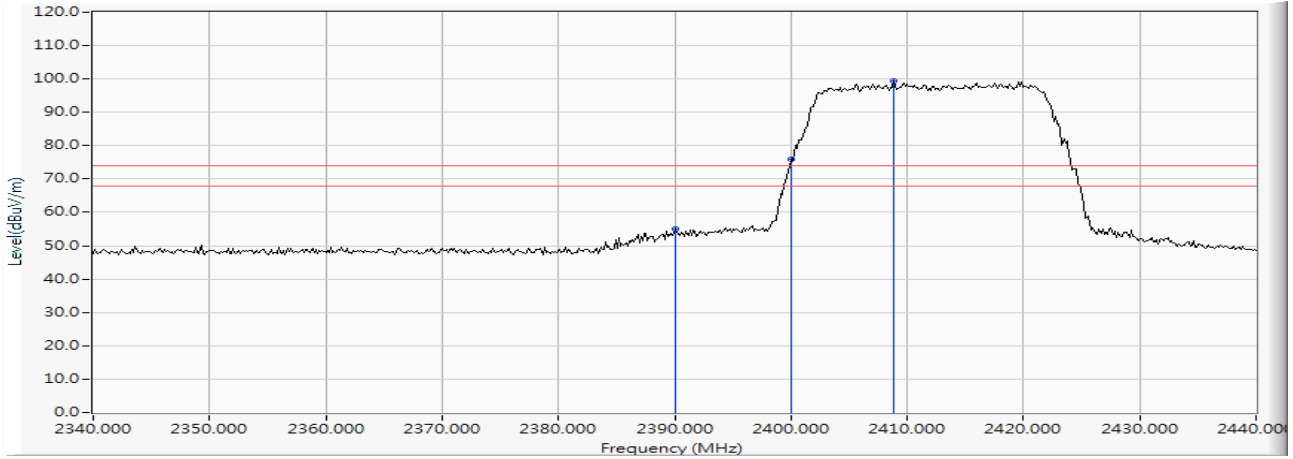

		Frequency (MHz)	Correct Factor (dB)	Reading Level (dBµV)	Measure Level (dBµV/m)	Margin (dB)	Limit (dBµV/m)	Detector Type
1		2390.000	12.186	42.880	55.066	-18.934	74.000	PEAK
2		2400.000	12.235	63.582	75.818	--	--	PEAK
3	*	2408.841	12.252	87.057	99.309	--	--	PEAK

Note:

1. All readings above 1GHz are performed with peak and/or average measurements as necessary.
2. Measurement Level = Reading Level + Correct Factor.
3. The average measurement was not performed when the peak measured data under the limit of average detection.

Product : Software defined radio
 Test Item : Band Edge
 Test Mode : Mode 1: Transmit_Dipole (A1+ A2+ B1+ B2) (2412MHz)
 Test Date : 2018/12/12

Horizontal

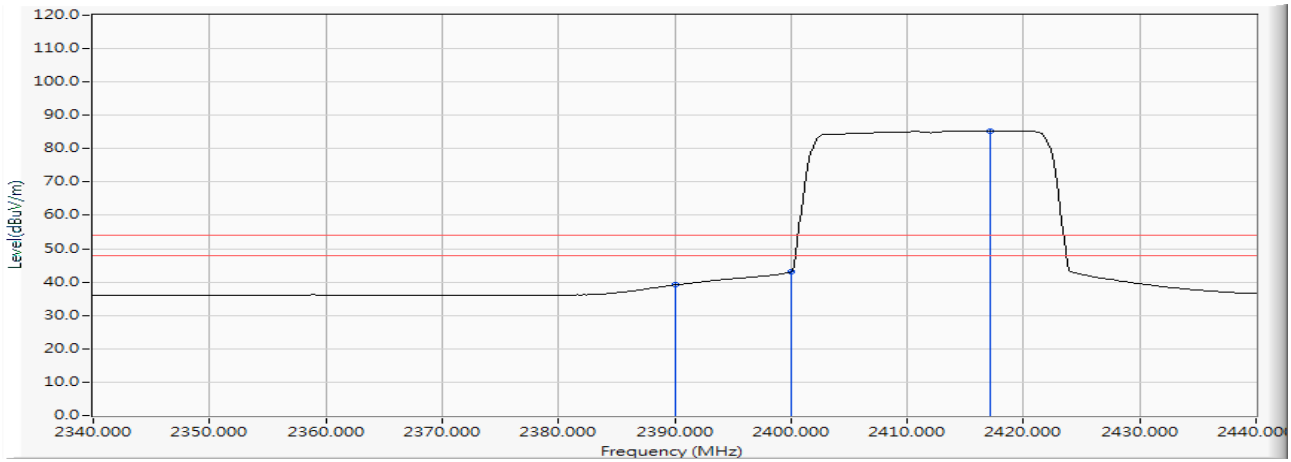

		Frequency (MHz)	Correct Factor (dB)	Reading Level (dBµV)	Measure Level (dBµV/m)	Margin (dB)	Limit (dBµV/m)	Detector Type
1		2390.000	12.186	26.906	39.092	-14.908	54.000	AVERAGE
2		2400.000	12.235	30.828	43.064	--	--	AVERAGE
3	*	2417.101	12.261	73.092	85.352	--	--	AVERAGE

Note:

1. All readings above 1GHz are performed with peak and/or average measurements as necessary.
2. Measurement Level = Reading Level + Correct Factor.
3. The average measurement was not performed when the peak measured data under the limit of average detection.

Product : Software defined radio
 Test Item : Band Edge
 Test Mode : Mode 1: Transmit_Dipole (A1+ A2+ B1+ B2) (2412MHz)
 Test Date : 2018/12/12

Vertical

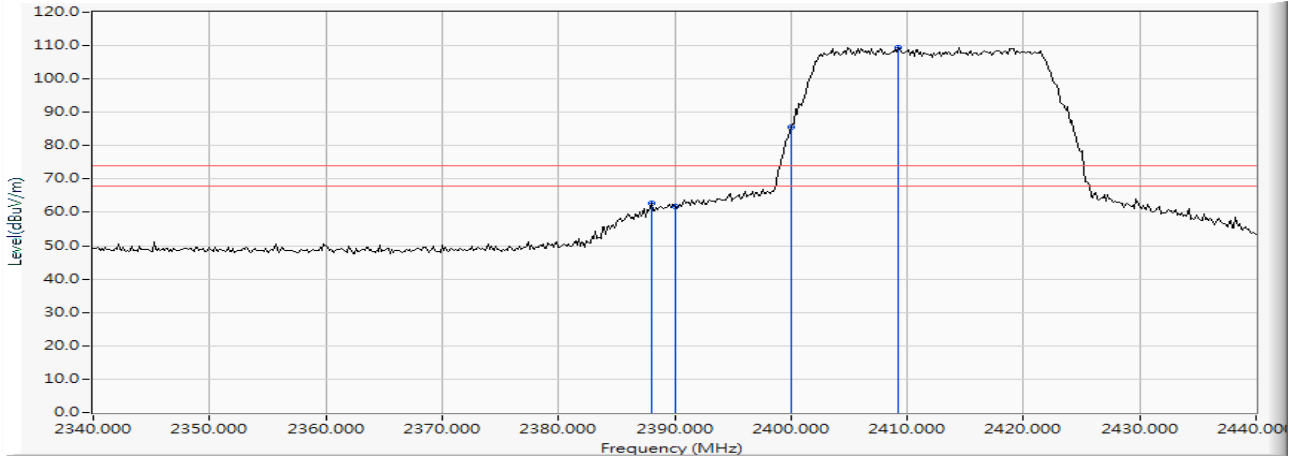

		Frequency (MHz)	Correct Factor (dB)	Reading Level (dBµV)	Measure Level (dBµV/m)	Margin (dB)	Limit (dBµV/m)	Detector Type
1		2387.971	12.176	50.465	62.641	-11.359	74.000	PEAK
2		2390.000	12.186	49.677	61.863	-12.137	74.000	PEAK
3		2400.000	12.235	73.184	85.420	--	--	PEAK
4	*	2409.275	12.253	97.043	109.295	--	--	PEAK

Note:

1. All readings above 1GHz are performed with peak and/or average measurements as necessary.
2. Measurement Level = Reading Level + Correct Factor.
3. The average measurement was not performed when the peak measured data under the limit of average detection.

Product : Software defined radio
 Test Item : Band Edge
 Test Mode : Mode 1: Transmit_Dipole (A1+ A2+ B1+ B2) (2412MHz)
 Test Date : 2018/12/12

Vertical

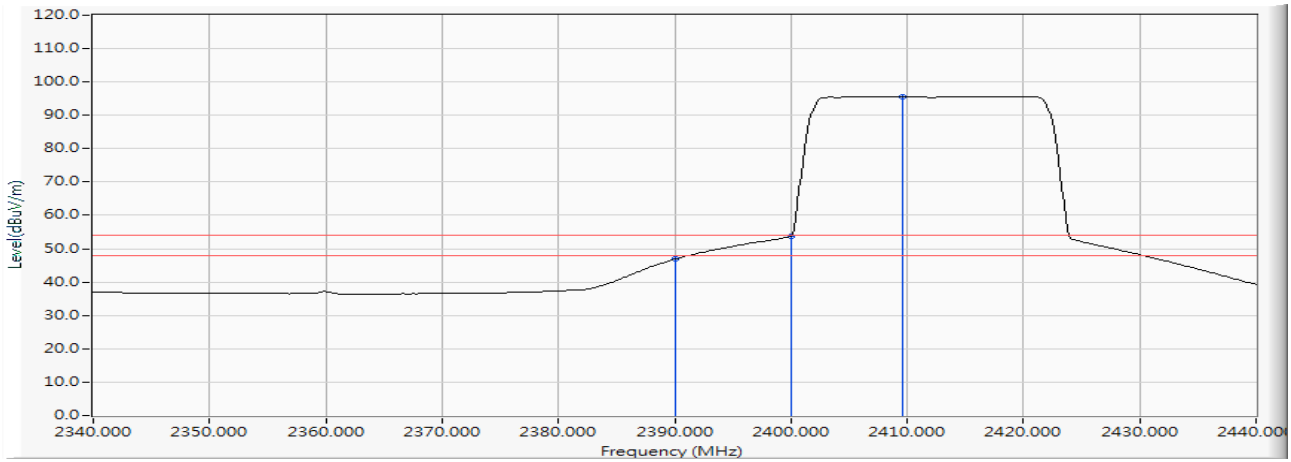

		Frequency (MHz)	Correct Factor (dB)	Reading Level (dBµV)	Measure Level (dBµV/m)	Margin (dB)	Limit (dBµV/m)	Detector Type
1		2390.000	12.186	34.665	46.851	-7.149	54.000	AVERAGE
2		2400.000	12.235	41.528	53.764	--	--	AVERAGE
3	*	2409.565	12.253	83.433	95.685	--	--	AVERAGE

Note:

1. All readings above 1GHz are performed with peak and/or average measurements as necessary.
2. Measurement Level = Reading Level + Correct Factor.
3. The average measurement was not performed when the peak measured data under the limit of average detection.

Product : Software defined radio
 Test Item : Band Edge
 Test Mode : Mode 1: Transmit_Dipole (A1+ A2+ B1+ B2) (2462MHz)
 Test Date : 2018/12/12

Horizontal

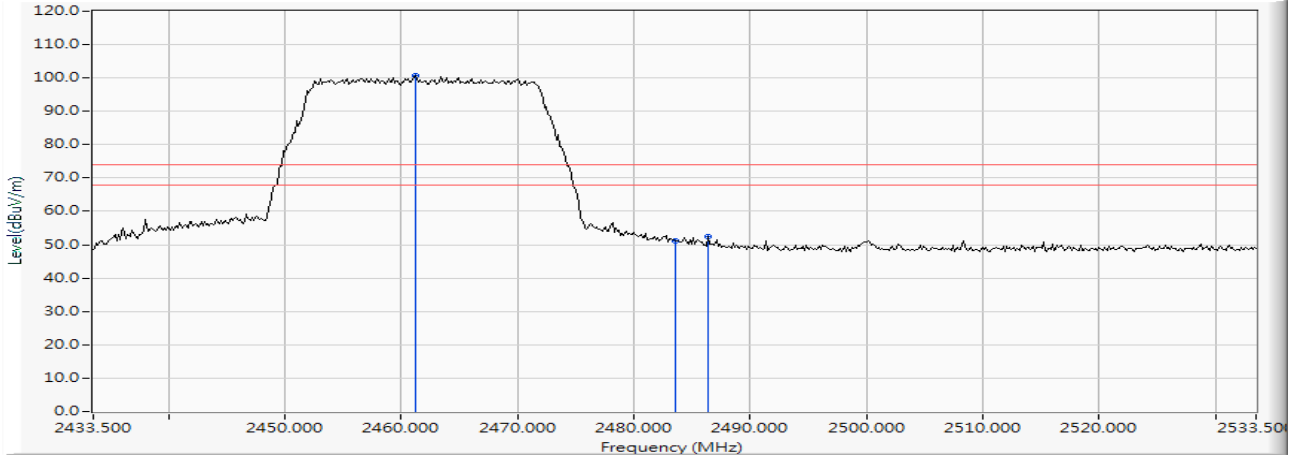

		Frequency (MHz)	Correct Factor (dB)	Reading Level (dBµV)	Measure Level (dBµV/m)	Margin (dB)	Limit (dBµV/m)	Detector Type
1	*	2461.181	12.359	88.271	100.630	--	--	PEAK
2		2483.500	12.433	38.752	51.185	-22.815	74.000	PEAK
3		2486.399	12.435	39.921	52.356	-21.644	74.000	PEAK

Note:

1. All readings above 1GHz are performed with peak and/or average measurements as necessary.
2. Measurement Level = Reading Level + Correct Factor.
3. The average measurement was not performed when the peak measured data under the limit of average detection.

Product : Software defined radio
 Test Item : Band Edge
 Test Mode : Mode 1: Transmit_Dipole (A1+ A2+ B1+ B2) (2462MHz)
 Test Date : 2018/12/12

Horizontal

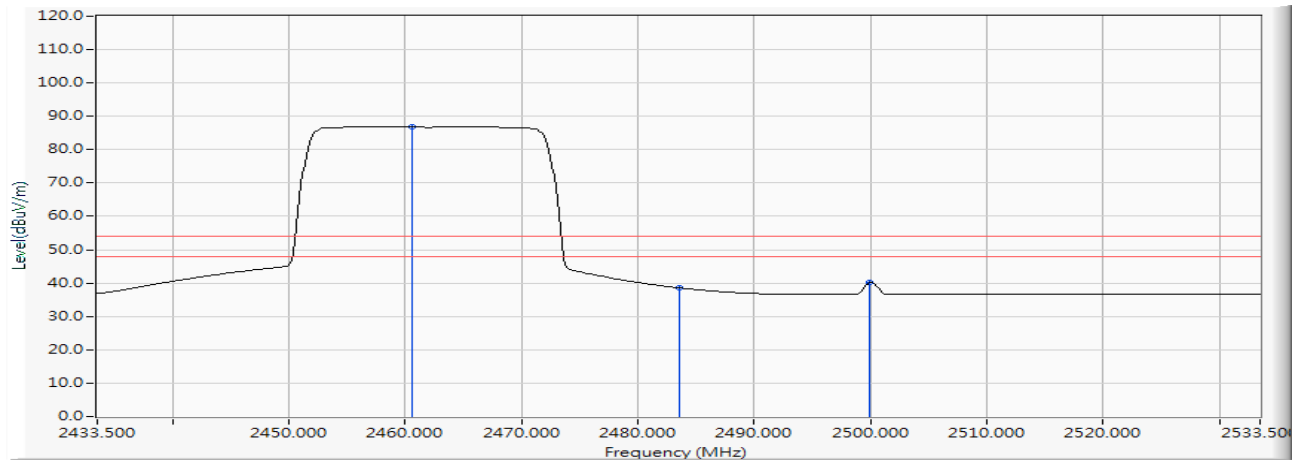

		Frequency (MHz)	Correct Factor (dB)	Reading Level (dBµV)	Measure Level (dBµV/m)	Margin (dB)	Limit (dBµV/m)	Detector Type
1	*	2460.601	12.356	74.651	87.007	--	--	AVERAGE
2		2483.500	12.433	26.145	38.578	-15.422	54.000	AVERAGE
3		2499.877	12.481	27.609	40.090	-13.910	54.000	AVERAGE

Note:

1. All readings above 1GHz are performed with peak and/or average measurements as necessary.
2. Measurement Level = Reading Level + Correct Factor.
3. The average measurement was not performed when the peak measured data under the limit of average detection.

Product : Software defined radio
 Test Item : Band Edge
 Test Mode : Mode 1: Transmit_Dipole (A1+ A2+ B1+ B2) (2462MHz)
 Test Date : 2018/12/12

Vertical

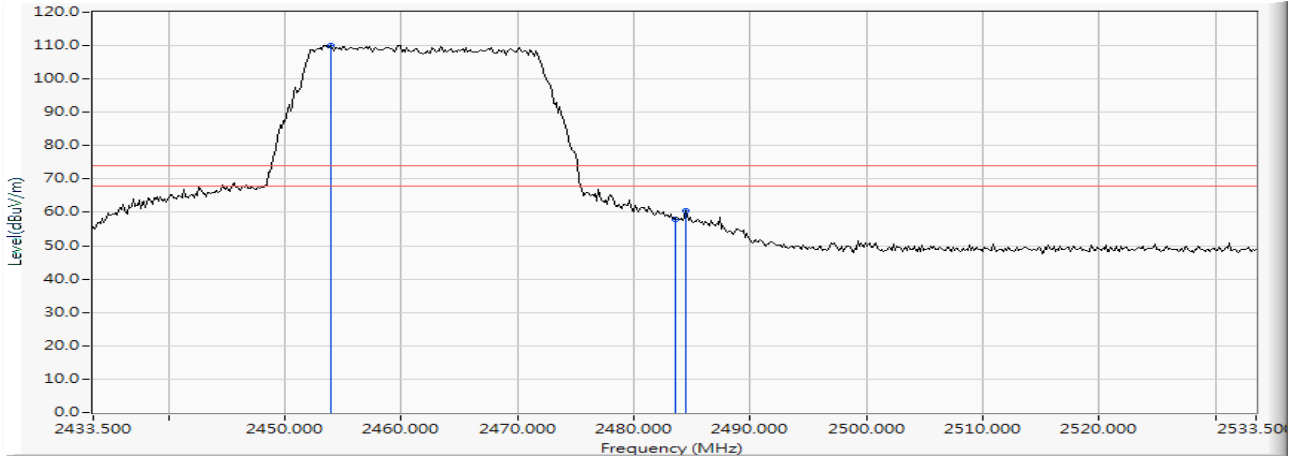

		Frequency (MHz)	Correct Factor (dB)	Reading Level (dBµV)	Measure Level (dBµV/m)	Margin (dB)	Limit (dBµV/m)	Detector Type
1	*	2453.935	12.332	97.847	110.179	--	--	PEAK
2		2483.500	12.433	45.535	57.968	-16.032	74.000	PEAK
3		2484.514	12.433	47.996	60.430	-13.570	74.000	PEAK

Note:

1. All readings above 1GHz are performed with peak and/or average measurements as necessary.
2. Measurement Level = Reading Level + Correct Factor.
3. The average measurement was not performed when the peak measured data under the limit of average detection.

Product : Software defined radio
 Test Item : Band Edge
 Test Mode : Mode 1: Transmit_Dipole (A1+ A2+ B1+ B2) (2462MHz)
 Test Date : 2018/12/12

Vertical

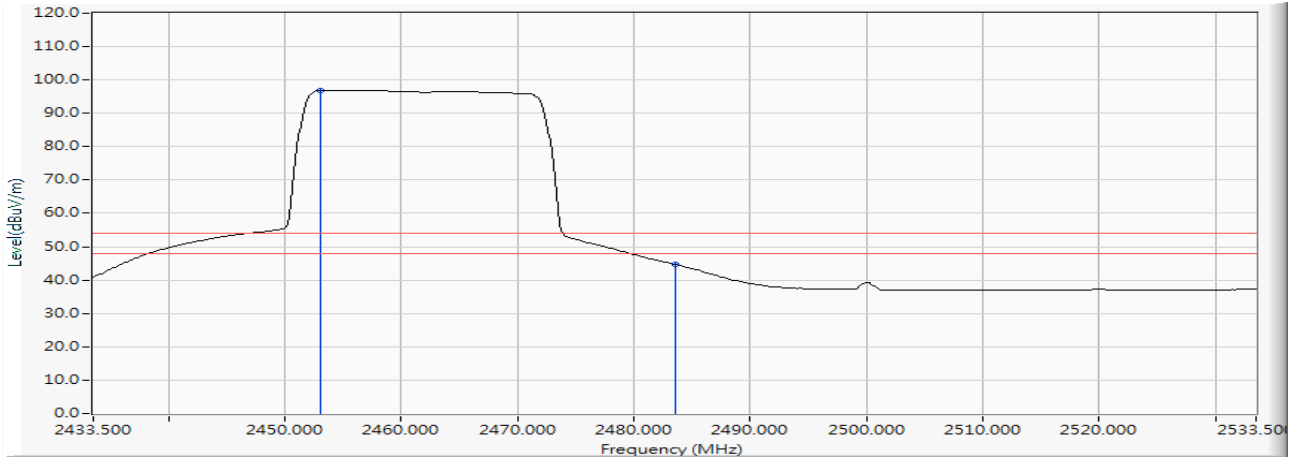

		Frequency (MHz)	Correct Factor (dB)	Reading Level (dBµV)	Measure Level (dBµV/m)	Margin (dB)	Limit (dBµV/m)	Detector Type
1	*	2453.065	12.331	84.614	96.946	--	--	AVERAGE
2		2483.500	12.433	32.367	44.800	-9.200	54.000	AVERAGE

Note:

1. All readings above 1GHz are performed with peak and/or average measurements as necessary.
2. Measurement Level = Reading Level + Correct Factor.
3. The average measurement was not performed when the peak measured data under the limit of average detection.

Product : Software defined radio
 Test Item : Band Edge
 Test Mode : Mode 1: Transmit_Dipole (B1+ B2) (2412MHz)
 Test Date : 2018/12/12

Horizontal

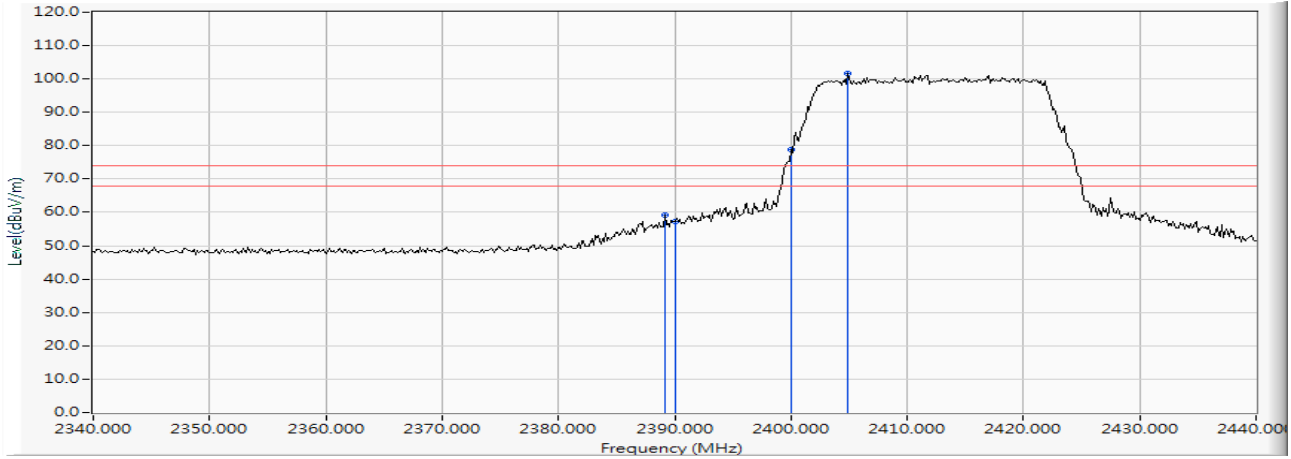

		Frequency (MHz)	Correct Factor (dB)	Reading Level (dBµV)	Measure Level (dBµV/m)	Margin (dB)	Limit (dBµV/m)	Detector Type
1		2389.130	12.182	47.134	59.316	-14.684	74.000	PEAK
2		2390.000	12.186	44.935	57.121	-16.879	74.000	PEAK
3		2400.000	12.235	66.520	78.756	--	--	PEAK
4	*	2404.928	12.248	89.390	101.638	--	--	PEAK

Note:

1. All readings above 1GHz are performed with peak and/or average measurements as necessary.
2. Measurement Level = Reading Level + Correct Factor.
3. The average measurement was not performed when the peak measured data under the limit of average detection.

Product : Software defined radio
 Test Item : Band Edge
 Test Mode : Mode 1: Transmit_Dipole (B1+ B2) (2412MHz)
 Test Date : 2018/12/12

Horizontal

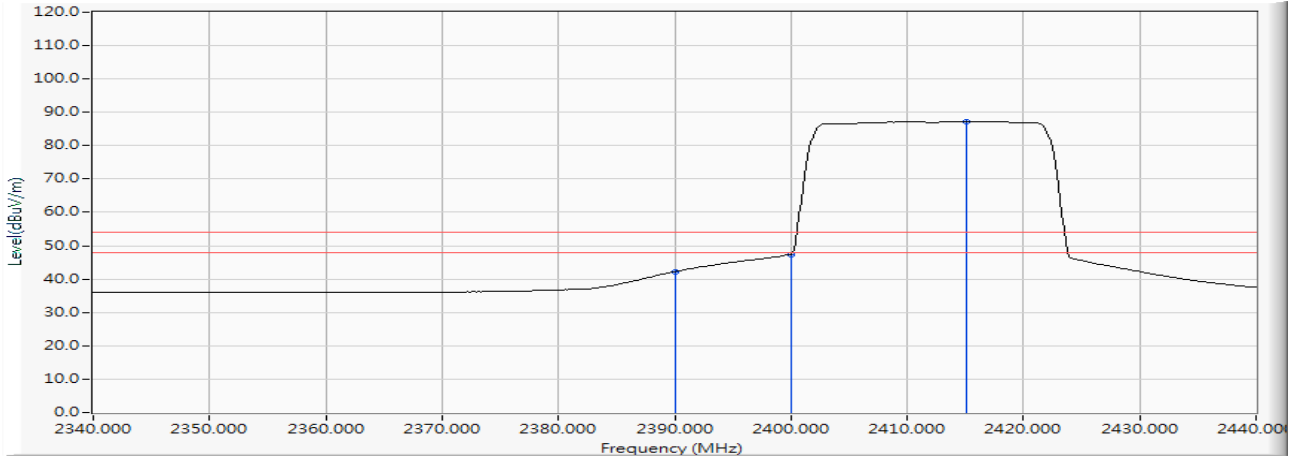

		Frequency (MHz)	Correct Factor (dB)	Reading Level (dBµV)	Measure Level (dBµV/m)	Margin (dB)	Limit (dBµV/m)	Detector Type
1		2390.000	12.186	30.017	42.203	-11.797	54.000	AVERAGE
2		2400.000	12.235	35.179	47.415	--	--	AVERAGE
3	*	2415.072	12.259	74.940	87.198	--	--	AVERAGE

Note:

1. All readings above 1GHz are performed with peak and/or average measurements as necessary.
2. Measurement Level = Reading Level + Correct Factor.
3. The average measurement was not performed when the peak measured data under the limit of average detection.

Product : Software defined radio
 Test Item : Band Edge
 Test Mode : Mode 1: Transmit_Dipole (B1+ B2) (2412MHz)
 Test Date : 2018/12/12

Vertical

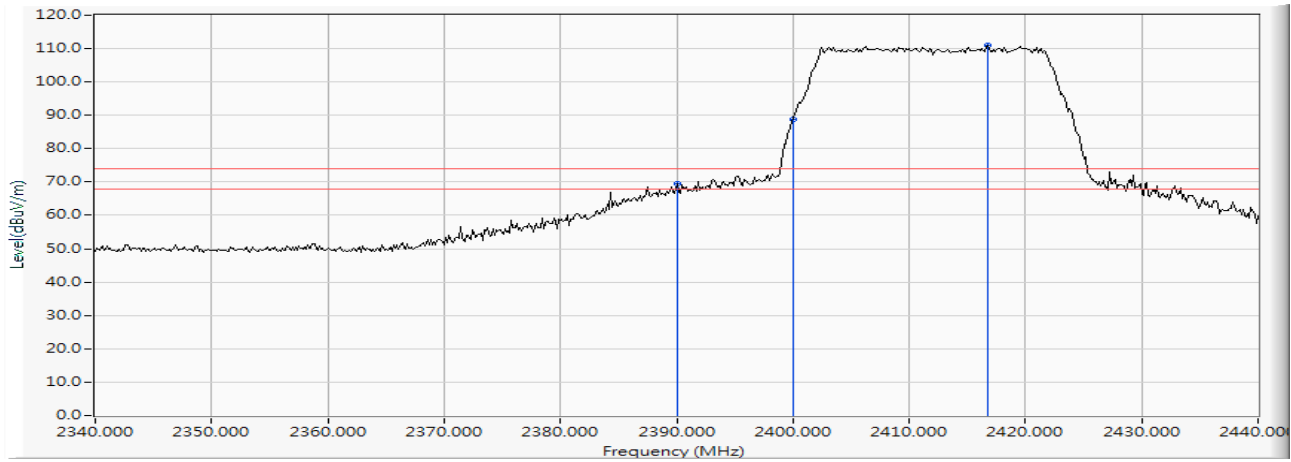

		Frequency (MHz)	Correct Factor (dB)	Reading Level (dBµV)	Measure Level (dBµV/m)	Margin (dB)	Limit (dBµV/m)	Detector Type
1		2390.000	12.186	57.167	69.353	-4.647	74.000	PEAK
2		2400.000	12.235	76.693	88.929	--	--	PEAK
3	*	2416.812	12.260	98.657	110.917	--	--	PEAK

Note:

1. All readings above 1GHz are performed with peak and/or average measurements as necessary.
2. Measurement Level = Reading Level + Correct Factor.
3. The average measurement was not performed when the peak measured data under the limit of average detection.

Product : Software defined radio
 Test Item : Band Edge
 Test Mode : Mode 1: Transmit_Dipole (B1+ B2) (2412MHz)
 Test Date : 2018/12/12

Vertical

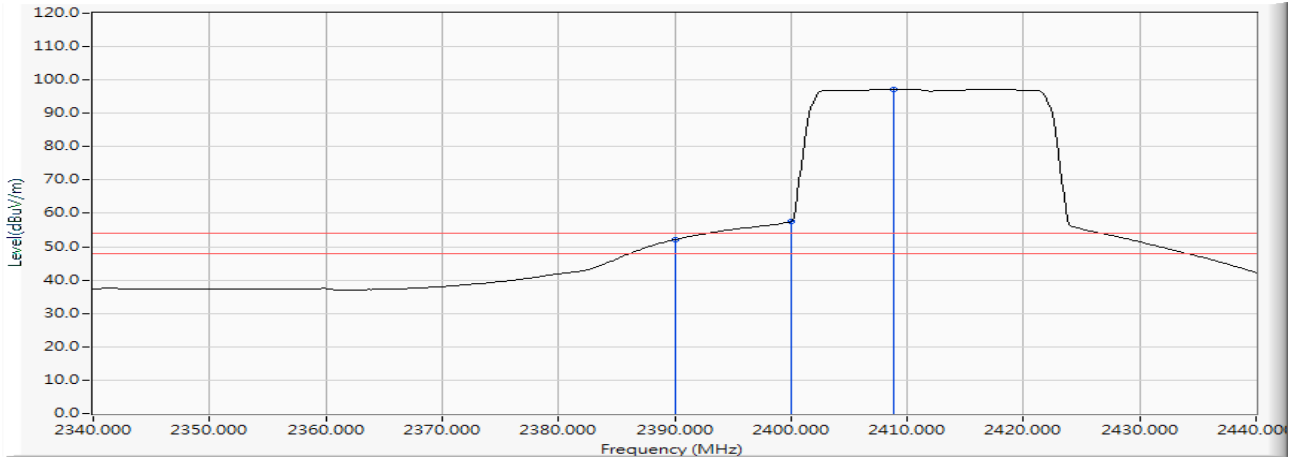

		Frequency (MHz)	Correct Factor (dB)	Reading Level (dBµV)	Measure Level (dBµV/m)	Margin (dB)	Limit (dBµV/m)	Detector Type
1		2390.000	12.186	39.935	52.121	-1.879	54.000	AVERAGE
2		2400.000	12.235	45.296	57.532	--	--	AVERAGE
3	*	2408.841	12.252	84.861	97.113	--	--	AVERAGE

Note:

1. All readings above 1GHz are performed with peak and/or average measurements as necessary.
2. Measurement Level = Reading Level + Correct Factor.
3. The average measurement was not performed when the peak measured data under the limit of average detection.

Product : Software defined radio
 Test Item : Band Edge
 Test Mode : Mode 1: Transmit_Dipole (B1+ B2) (2462MHz)
 Test Date : 2018/12/12

Horizontal

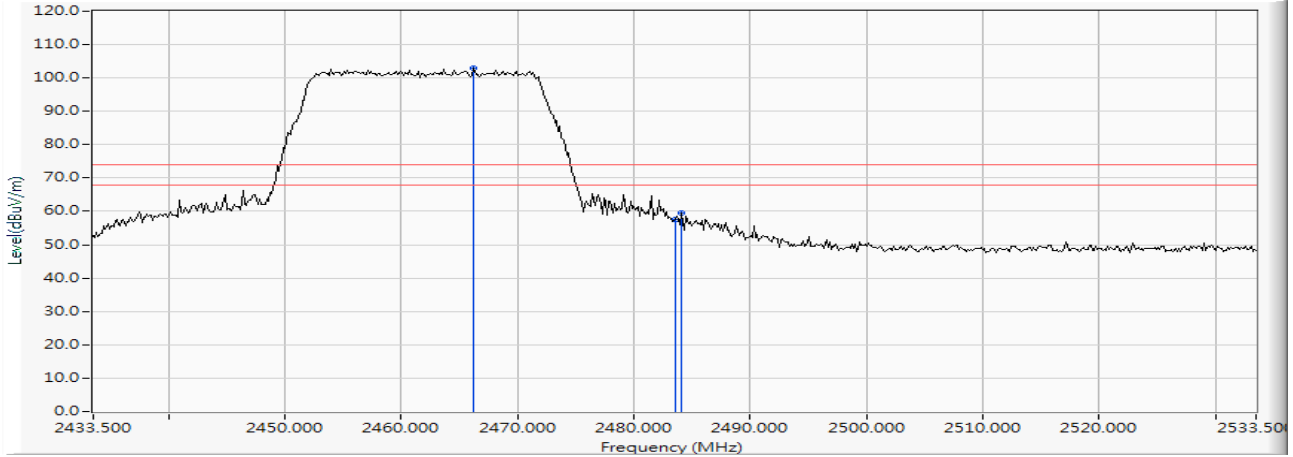

		Frequency (MHz)	Correct Factor (dB)	Reading Level (dBµV)	Measure Level (dBµV/m)	Margin (dB)	Limit (dBµV/m)	Detector Type
1	*	2466.254	12.387	90.547	102.934	--	--	PEAK
2		2483.500	12.433	45.044	57.477	-16.523	74.000	PEAK
3		2484.080	12.434	47.195	59.629	-14.371	74.000	PEAK

Note:

1. All readings above 1GHz are performed with peak and/or average measurements as necessary.
2. Measurement Level = Reading Level + Correct Factor.
3. The average measurement was not performed when the peak measured data under the limit of average detection.

Product : Software defined radio
 Test Item : Band Edge
 Test Mode : Mode 1: Transmit_Dipole (B1+ B2) (2462MHz)
 Test Date : 2018/12/12

Horizontal

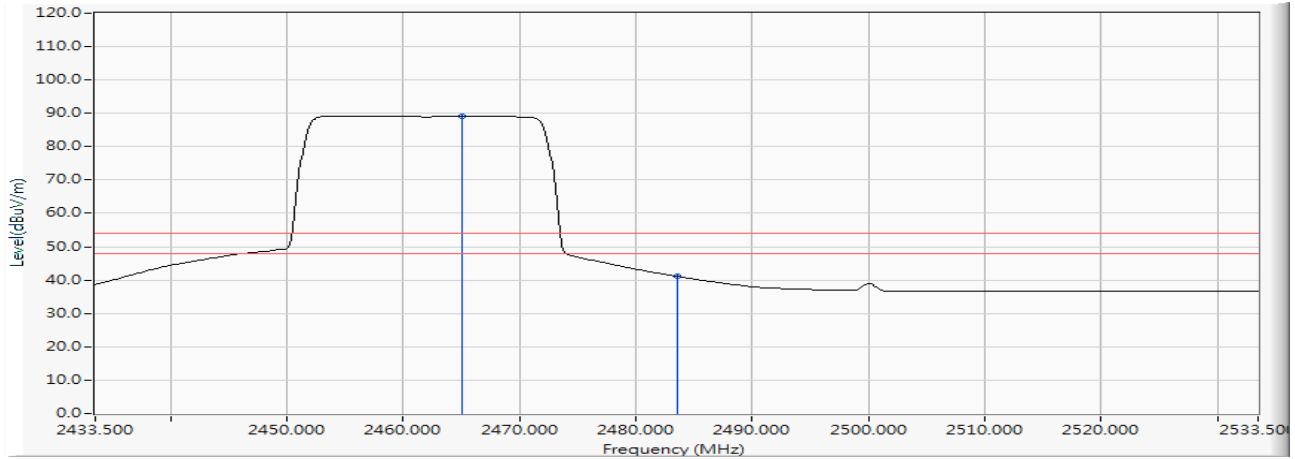

		Frequency (MHz)	Correct Factor (dB)	Reading Level (dBµV)	Measure Level (dBµV/m)	Margin (dB)	Limit (dBµV/m)	Detector Type
1	*	2465.094	12.381	76.820	89.201	--	--	AVERAGE
2		2483.500	12.433	28.730	41.163	-12.837	54.000	AVERAGE

Note:

1. All readings above 1GHz are performed with peak and/or average measurements as necessary.
2. Measurement Level = Reading Level + Correct Factor.
3. The average measurement was not performed when the peak measured data under the limit of average detection.

Product : Software defined radio
 Test Item : Band Edge
 Test Mode : Mode 1: Transmit_Dipole (B1+ B2) (2462MHz)
 Test Date : 2018/12/12

Vertical

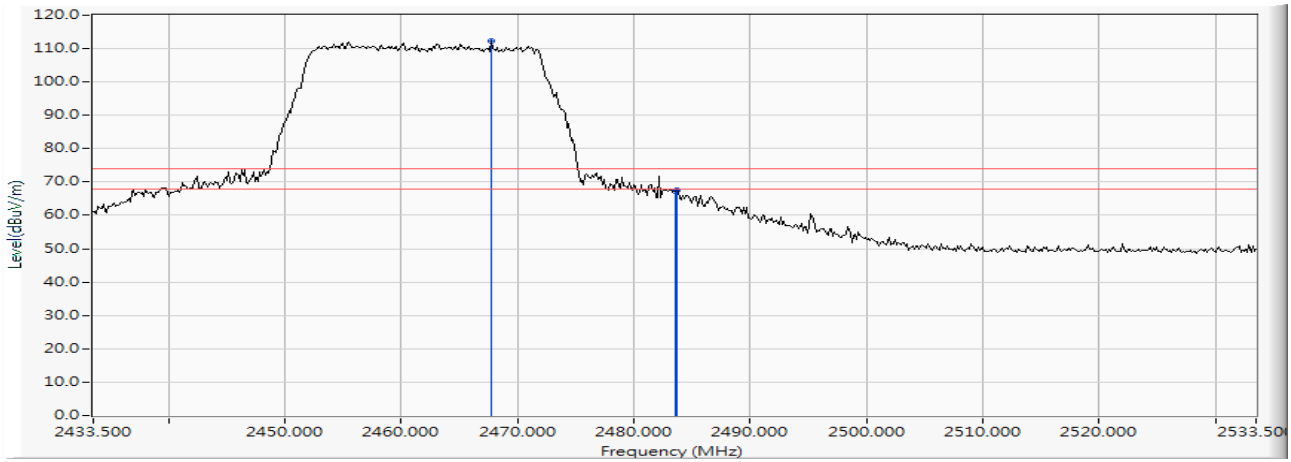

		Frequency (MHz)	Correct Factor (dB)	Reading Level (dBµV)	Measure Level (dBµV/m)	Margin (dB)	Limit (dBµV/m)	Detector Type
1	*	2467.703	12.395	99.849	112.244	--	--	PEAK
2		2483.500	12.433	54.650	67.083	-6.917	74.000	PEAK
3		2483.645	12.433	54.969	67.402	-6.598	74.000	PEAK

Note:

1. All readings above 1GHz are performed with peak and/or average measurements as necessary.
2. Measurement Level = Reading Level + Correct Factor.
3. The average measurement was not performed when the peak measured data under the limit of average detection.

Product : Software defined radio
 Test Item : Band Edge
 Test Mode : Mode 1: Transmit_Dipole (B1+ B2) (2462MHz)
 Test Date : 2018/12/12

Vertical

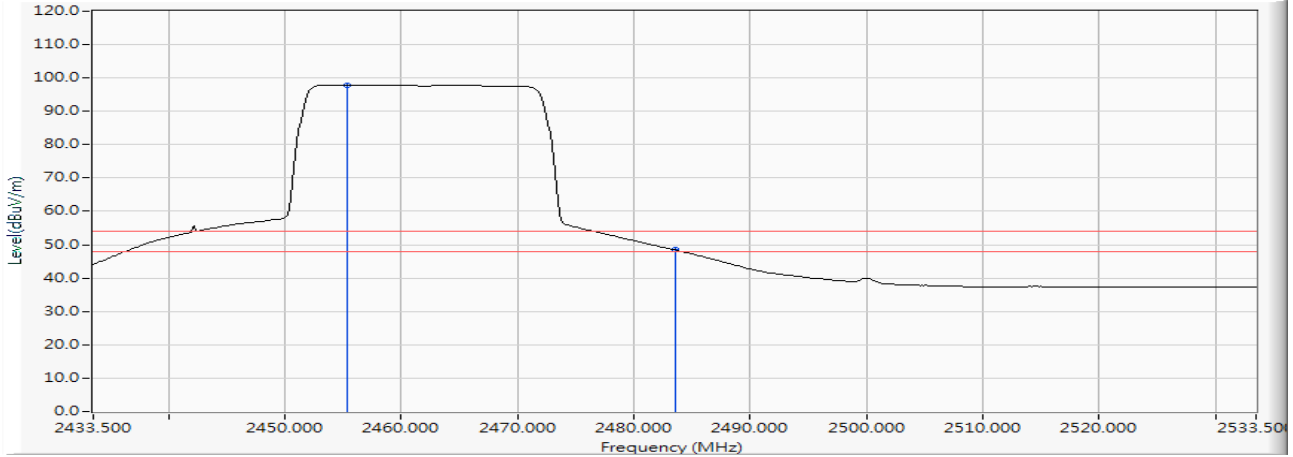

		Frequency (MHz)	Correct Factor (dB)	Reading Level (dBµV)	Measure Level (dBµV/m)	Margin (dB)	Limit (dBµV/m)	Detector Type
1	*	2455.384	12.331	85.581	97.912	--	--	AVERAGE
2		2483.500	12.433	36.037	48.470	-5.530	54.000	AVERAGE

Note:

1. All readings above 1GHz are performed with peak and/or average measurements as necessary.
2. Measurement Level = Reading Level + Correct Factor.
3. The average measurement was not performed when the peak measured data under the limit of average detection.

Product : Software defined radio
 Test Item : Band Edge
 Test Mode : Mode 2: Transmit_Patch (A1+ A2) (2412MHz)
 Test Date : 2019/01/09

Horizontal

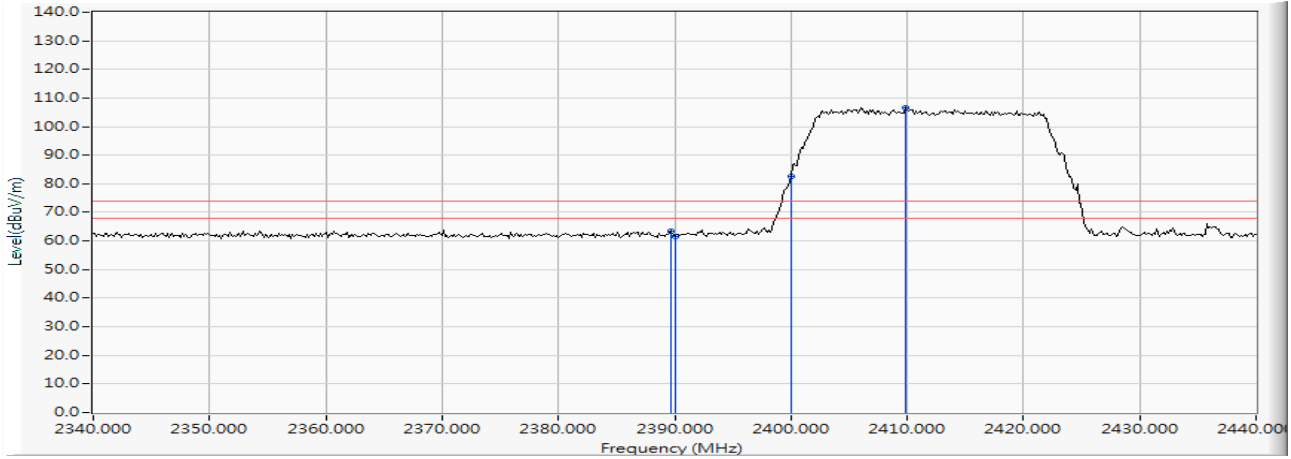

		Frequency (MHz)	Correct Factor (dB)	Reading Level (dBµV)	Measure Level (dBµV/m)	Margin (dB)	Limit (dBµV/m)	Detector Type
1		2389.710	36.455	26.883	63.338	-10.662	74.000	PEAK
2		2390.000	36.456	25.119	61.575	-12.425	74.000	PEAK
3		2400.000	36.503	45.984	82.487	--	--	PEAK
4	*	2409.855	36.519	70.147	106.666	--	--	PEAK

Note:

1. All readings above 1GHz are performed with peak and/or average measurements as necessary.
2. Measurement Level = Reading Level + Correct Factor.
3. The average measurement was not performed when the peak measured data under the limit of average detection.

Product : Software defined radio
 Test Item : Band Edge
 Test Mode : Mode 2: Transmit_Patch (A1+ A2) (2412MHz)
 Test Date : 2019/01/09

Horizontal

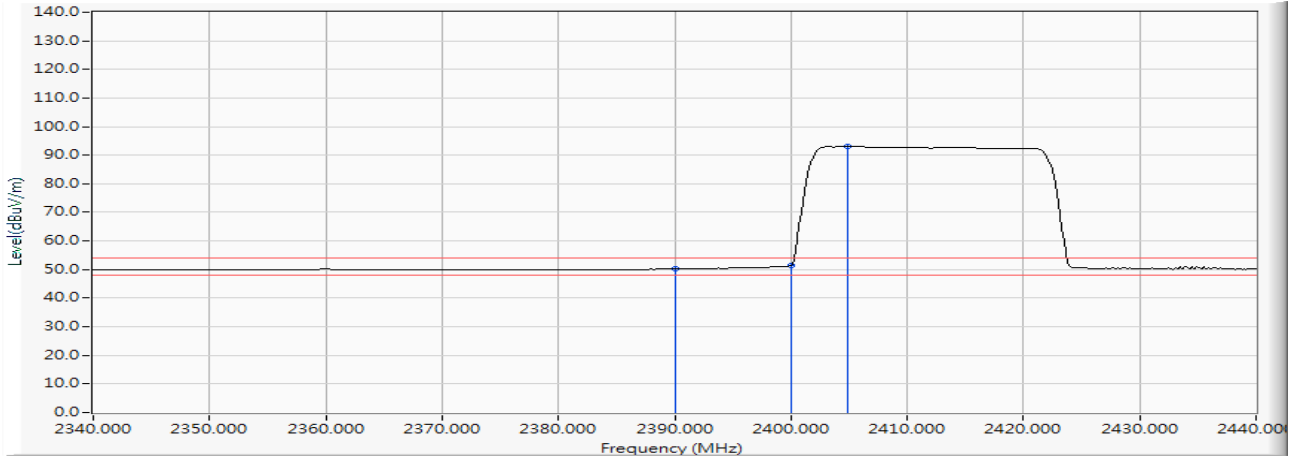

		Frequency (MHz)	Correct Factor (dB)	Reading Level (dBµV)	Measure Level (dBµV/m)	Margin (dB)	Limit (dBµV/m)	Detector Type
1		2390.000	36.456	13.732	50.188	-3.812	54.000	AVERAGE
2		2400.000	36.503	14.863	51.366	-2.634	54.000	AVERAGE
3	*	2404.928	36.515	56.462	92.977	--	--	AVERAGE

Note:

1. All readings above 1GHz are performed with peak and/or average measurements as necessary.
2. Measurement Level = Reading Level + Correct Factor.
3. The average measurement was not performed when the peak measured data under the limit of average detection.

Product : Software defined radio
 Test Item : Band Edge
 Test Mode : Mode 2: Transmit_Patch (A1+ A2) (2412MHz)
 Test Date : 2019/01/09

Vertical

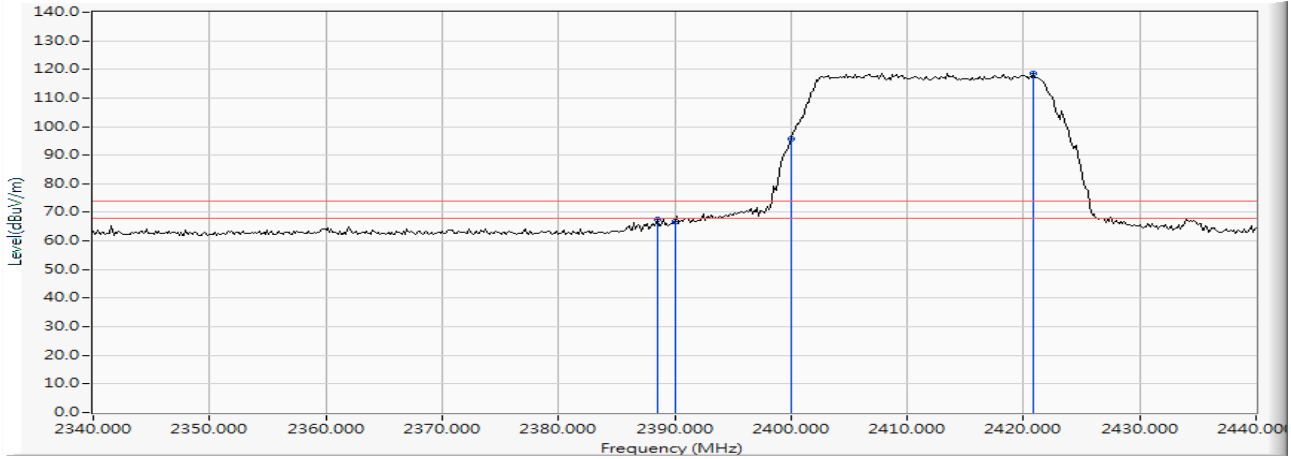

		Frequency (MHz)	Correct Factor (dB)	Reading Level (dBµV)	Measure Level (dBµV/m)	Margin (dB)	Limit (dBµV/m)	Detector Type
1		2388.551	36.449	31.088	67.537	-6.463	74.000	PEAK
2		2390.000	36.456	30.412	66.868	-7.132	74.000	PEAK
3		2400.000	36.503	59.317	95.820	--	--	PEAK
4	*	2420.870	36.531	82.008	118.539	--	--	PEAK

Note:

1. All readings above 1GHz are performed with peak and/or average measurements as necessary.
2. Measurement Level = Reading Level + Correct Factor.
3. The average measurement was not performed when the peak measured data under the limit of average detection.

Product : Software defined radio
 Test Item : Band Edge
 Test Mode : Mode 2: Transmit_Patch (A1+ A2) (2412MHz)
 Test Date : 2019/01/09

Vertical

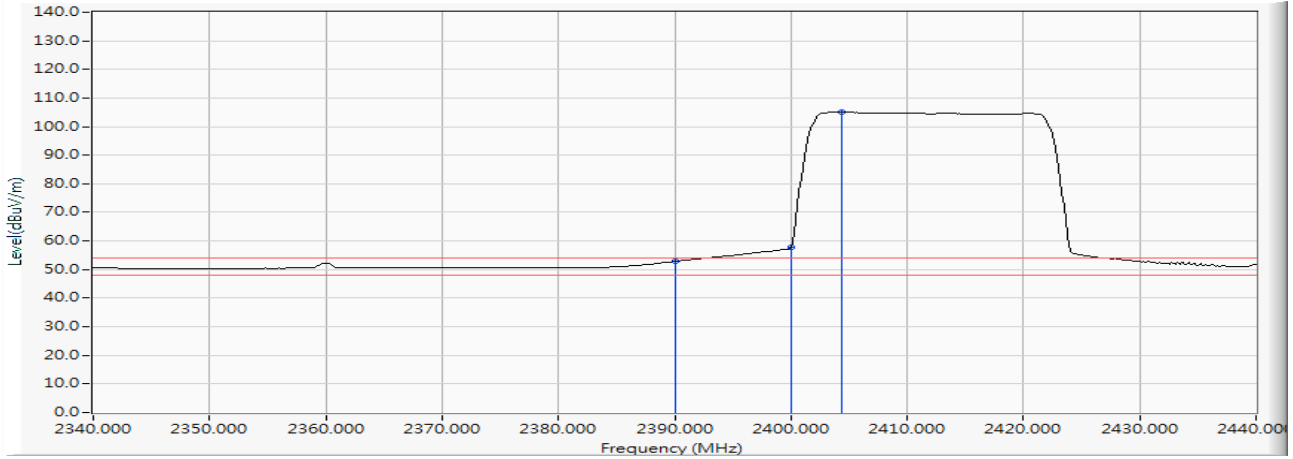

		Frequency (MHz)	Correct Factor (dB)	Reading Level (dBµV)	Measure Level (dBµV/m)	Margin (dB)	Limit (dBµV/m)	Detector Type
1		2390.000	36.456	16.439	52.895	-1.105	54.000	AVERAGE
2		2400.000	36.503	21.399	57.902	--	--	AVERAGE
3	*	2404.348	36.515	68.446	104.961	--	--	AVERAGE

Note:

1. All readings above 1GHz are performed with peak and/or average measurements as necessary.
2. Measurement Level = Reading Level + Correct Factor.
3. The average measurement was not performed when the peak measured data under the limit of average detection.

Product : Software defined radio
 Test Item : Band Edge
 Test Mode : Mode 2: Transmit_Patch (A1+ A2) (2462MHz)
 Test Date : 2019/01/09

Horizontal

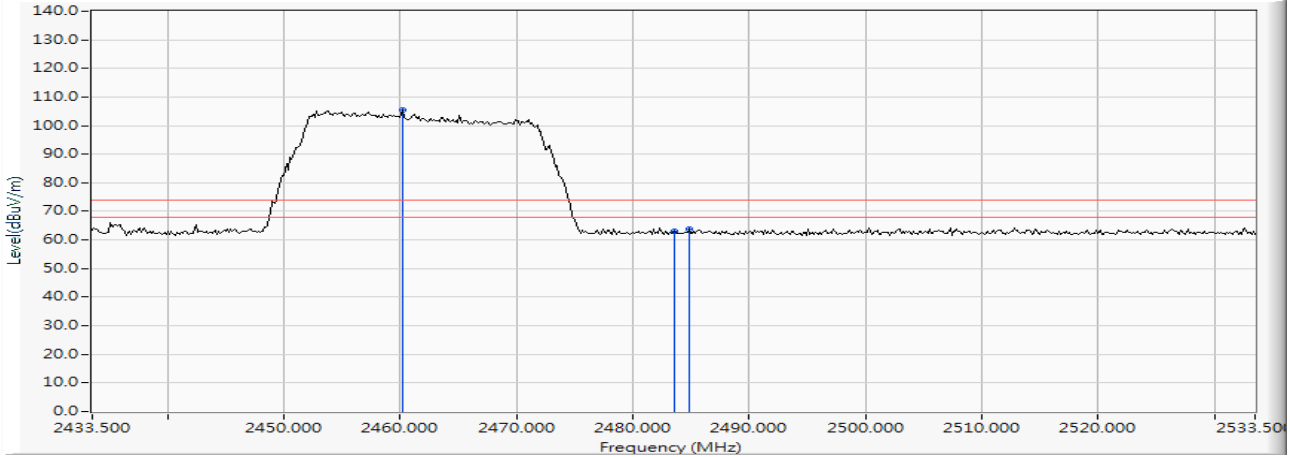

		Frequency (MHz)	Correct Factor (dB)	Reading Level (dBµV)	Measure Level (dBµV/m)	Margin (dB)	Limit (dBµV/m)	Detector Type
1	*	2460.167	36.610	68.895	105.506	--	--	PEAK
2		2483.500	36.686	26.256	62.942	-11.058	74.000	PEAK
3		2484.804	36.687	27.042	63.729	-10.271	74.000	PEAK

Note:

1. All readings above 1GHz are performed with peak and/or average measurements as necessary.
2. Measurement Level = Reading Level + Correct Factor.
3. The average measurement was not performed when the peak measured data under the limit of average detection.

Product : Software defined radio
 Test Item : Band Edge
 Test Mode : Mode 2: Transmit_Patch (A1+ A2) (2462MHz)
 Test Date : 2019/01/09

Horizontal

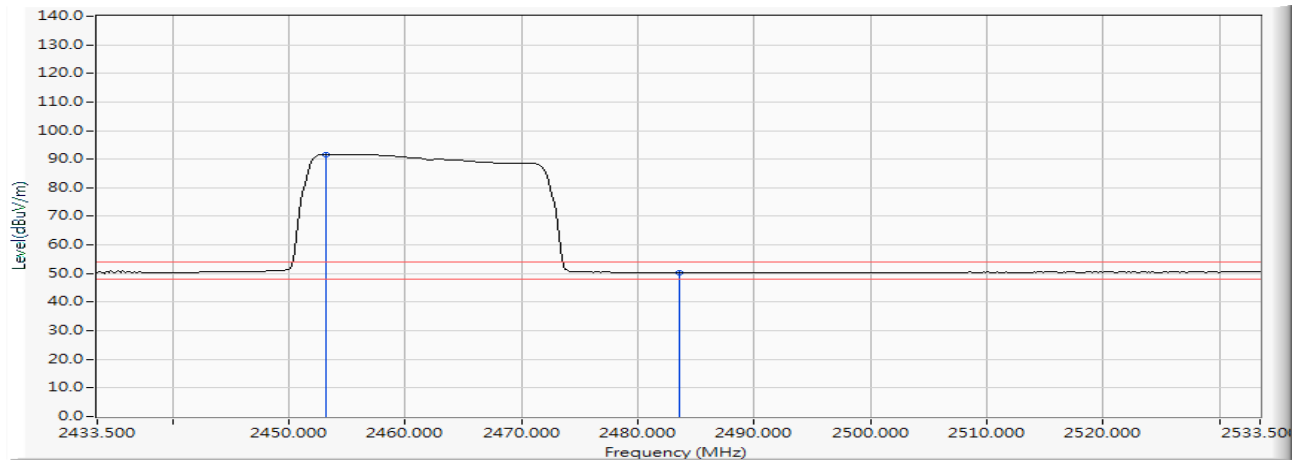

		Frequency (MHz)	Correct Factor (dB)	Reading Level (dBµV)	Measure Level (dBµV/m)	Margin (dB)	Limit (dBµV/m)	Detector Type
1	*	2453.210	36.591	55.170	91.761	--	--	AVERAGE
2		2483.500	36.686	13.687	50.373	-3.627	54.000	AVERAGE

Note:

1. All readings above 1GHz are performed with peak and/or average measurements as necessary.
2. Measurement Level = Reading Level + Correct Factor.
3. The average measurement was not performed when the peak measured data under the limit of average detection.

Product : Software defined radio
 Test Item : Band Edge
 Test Mode : Mode 2: Transmit_Patch (A1+ A2) (2462MHz)
 Test Date : 2019/01/09

Vertical

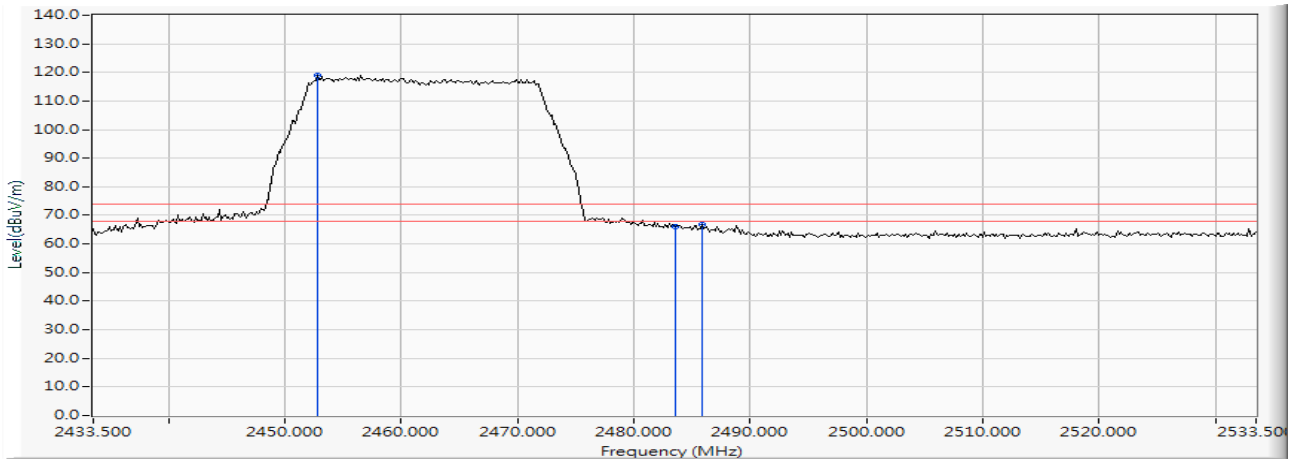

		Frequency (MHz)	Correct Factor (dB)	Reading Level (dBµV)	Measure Level (dBµV/m)	Margin (dB)	Limit (dBµV/m)	Detector Type
1	*	2452.775	36.591	82.411	119.002	--	--	PEAK
2		2483.500	36.686	29.317	66.003	-7.997	74.000	PEAK
3		2485.819	36.687	30.154	66.841	-7.159	74.000	PEAK

Note:

1. All readings above 1GHz are performed with peak and/or average measurements as necessary.
2. Measurement Level = Reading Level + Correct Factor.
3. The average measurement was not performed when the peak measured data under the limit of average detection.

Product : Software defined radio
 Test Item : Band Edge
 Test Mode : Mode 2: Transmit_Patch (A1+ A2) (2462MHz)
 Test Date : 2019/01/09

Vertical

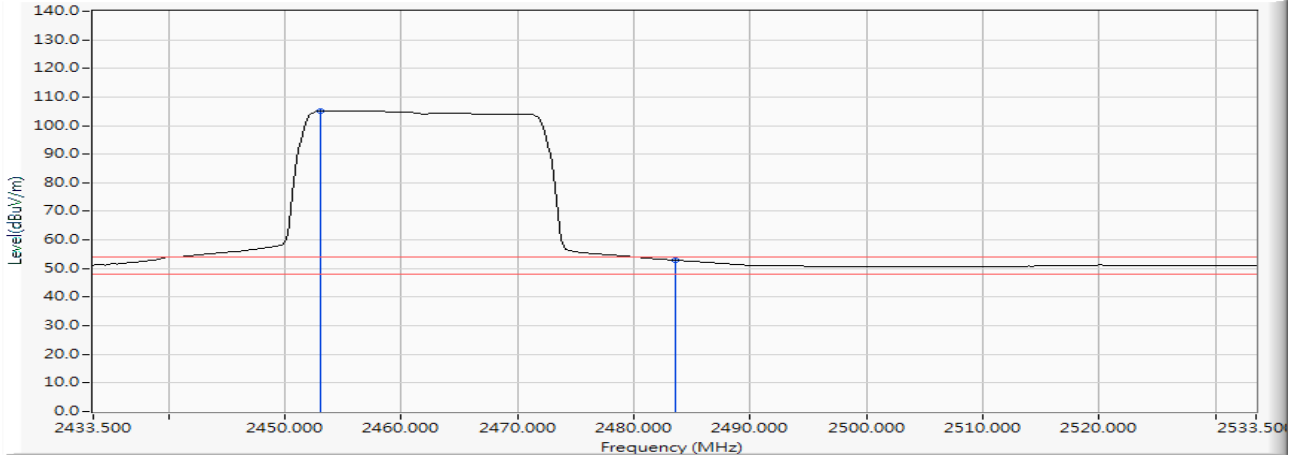

		Frequency (MHz)	Correct Factor (dB)	Reading Level (dBµV)	Measure Level (dBµV/m)	Margin (dB)	Limit (dBµV/m)	Detector Type
1	*	2453.065	36.590	68.558	105.149	--	--	AVERAGE
2		2483.500	36.686	16.265	52.951	-1.049	54.000	AVERAGE

Note:

1. All readings above 1GHz are performed with peak and/or average measurements as necessary.
2. Measurement Level = Reading Level + Correct Factor.
3. The average measurement was not performed when the peak measured data under the limit of average detection.

Product : Software defined radio
 Test Item : Band Edge
 Test Mode : Mode 2: Transmit_Patch (A1+ A2+ B1+ B2) (2412MHz)
 Test Date : 2019/01/09

Horizontal

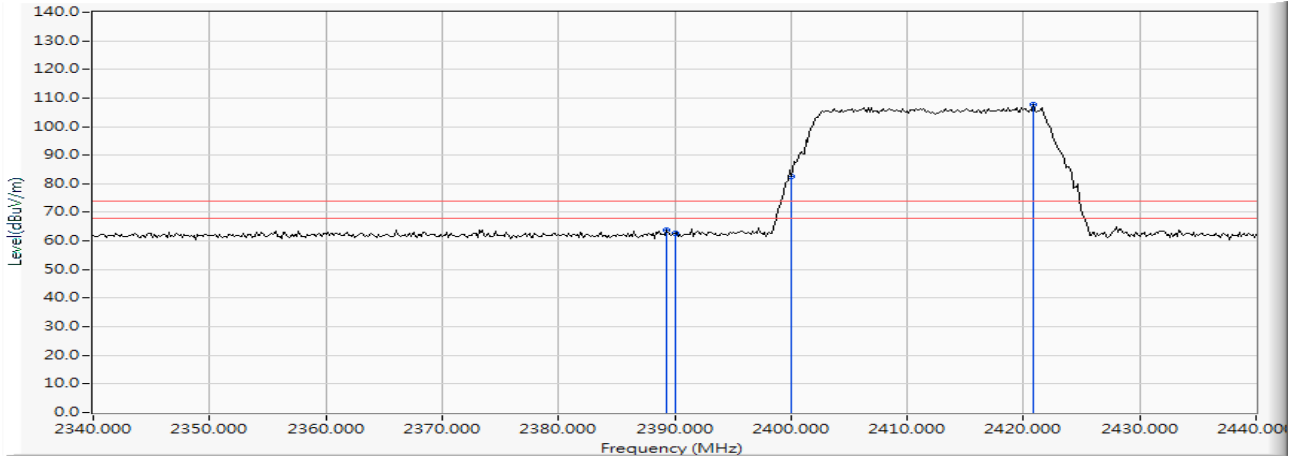

		Frequency (MHz)	Correct Factor (dB)	Reading Level (dBµV)	Measure Level (dBµV/m)	Margin (dB)	Limit (dBµV/m)	Detector Type
1		2389.275	36.452	27.325	63.778	-10.222	74.000	PEAK
2		2390.000	36.456	26.196	62.652	-11.348	74.000	PEAK
3		2400.000	36.503	45.991	82.494	--	--	PEAK
4	*	2420.870	36.531	71.226	107.757	--	--	PEAK

Note:

1. All readings above 1GHz are performed with peak and/or average measurements as necessary.
2. Measurement Level = Reading Level + Correct Factor.
3. The average measurement was not performed when the peak measured data under the limit of average detection.

Product : Software defined radio
 Test Item : Band Edge
 Test Mode : Mode 2: Transmit_Patch (A1+ A2+ B1+ B2) (2412MHz)
 Test Date : 2019/01/09

Horizontal

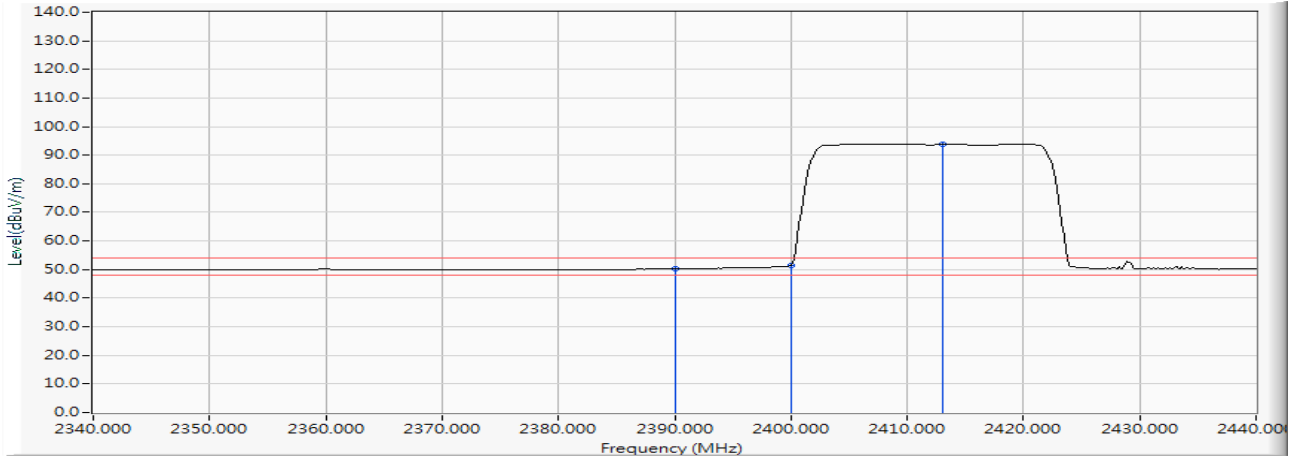

	Frequency (MHz)	Correct Factor (dB)	Reading Level (dBµV)	Measure Level (dBµV/m)	Margin (dB)	Limit (dBµV/m)	Detector Type
1	2390.000	36.456	13.805	50.261	-3.739	54.000	AVERAGE
2	2400.000	36.503	14.898	51.401	-2.599	54.000	AVERAGE
3	* 2413.043	36.522	57.315	93.837	--	--	AVERAGE

Note:

1. All readings above 1GHz are performed with peak and/or average measurements as necessary.
2. Measurement Level = Reading Level + Correct Factor.
3. The average measurement was not performed when the peak measured data under the limit of average detection.

Product : Software defined radio
 Test Item : Band Edge
 Test Mode : Mode 2: Transmit_Patch (A1+ A2+ B1+ B2) (2412MHz)
 Test Date : 2019/01/09

Vertical

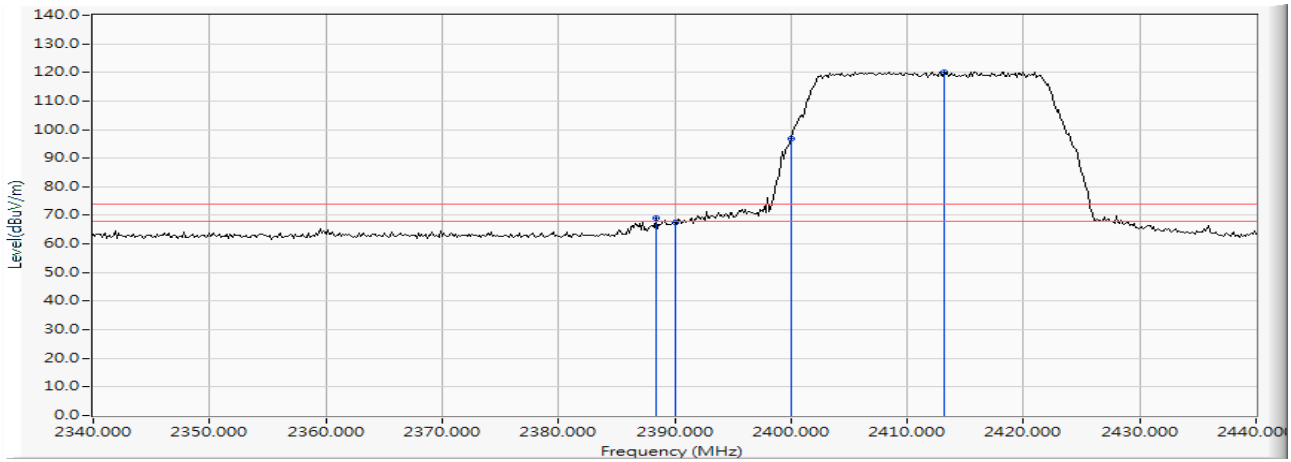

		Frequency (MHz)	Correct Factor (dB)	Reading Level (dBµV)	Measure Level (dBµV/m)	Margin (dB)	Limit (dBµV/m)	Detector Type
1		2388.406	36.448	32.462	68.911	-5.089	74.000	PEAK
2		2390.000	36.456	31.030	67.486	-6.514	74.000	PEAK
3		2400.000	36.503	60.482	96.985	--	--	PEAK
4	*	2413.188	36.522	83.714	120.236	--	--	PEAK

Note:

1. All readings above 1GHz are performed with peak and/or average measurements as necessary.
2. Measurement Level = Reading Level + Correct Factor.
3. The average measurement was not performed when the peak measured data under the limit of average detection.

Product : Software defined radio
 Test Item : Band Edge
 Test Mode : Mode 2: Transmit_Patch (A1+ A2+ B1+ B2) (2412MHz)
 Test Date : 2019/01/09

Vertical

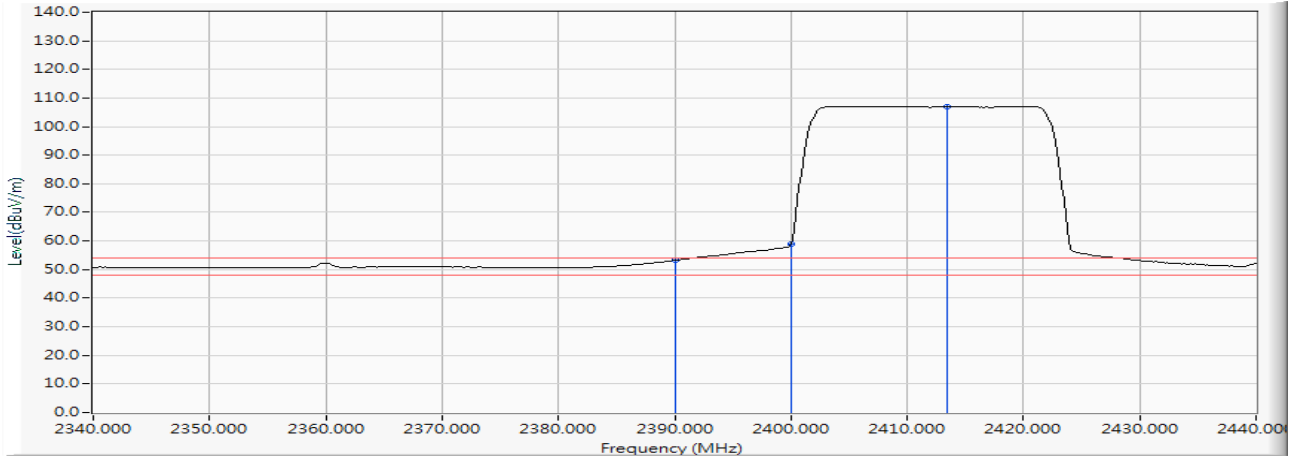

		Frequency (MHz)	Correct Factor (dB)	Reading Level (dBµV)	Measure Level (dBµV/m)	Margin (dB)	Limit (dBµV/m)	Detector Type
1		2390.000	36.456	16.828	53.284	-0.716	54.000	AVERAGE
2		2400.000	36.503	22.245	58.748	--	--	AVERAGE
3	*	2413.478	36.522	70.591	107.113	--	--	AVERAGE

Note:

1. All readings above 1GHz are performed with peak and/or average measurements as necessary.
2. Measurement Level = Reading Level + Correct Factor.
3. The average measurement was not performed when the peak measured data under the limit of average detection.

Product : Software defined radio
 Test Item : Band Edge
 Test Mode : Mode 2: Transmit_Patch (A1+ A2+ B1+ B2) (2462MHz)
 Test Date : 2019/01/09

Horizontal

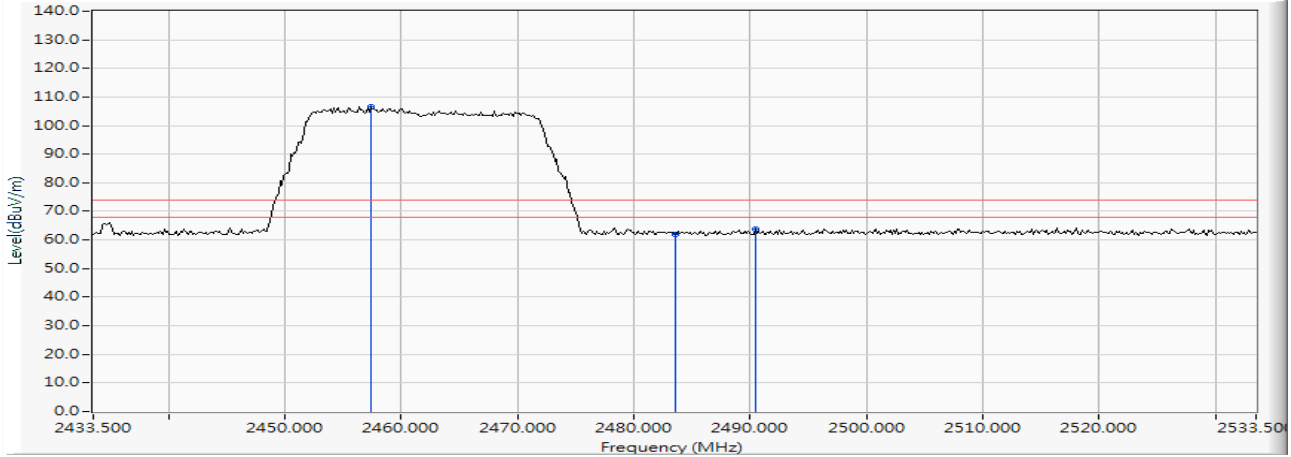

		Frequency (MHz)	Correct Factor (dB)	Reading Level (dBµV)	Measure Level (dBµV/m)	Margin (dB)	Limit (dBµV/m)	Detector Type
1	*	2457.413	36.597	70.068	106.664	--	--	PEAK
2		2483.500	36.686	25.384	62.070	-11.930	74.000	PEAK
3		2490.457	36.689	27.291	63.979	-10.021	74.000	PEAK

Note:

1. All readings above 1GHz are performed with peak and/or average measurements as necessary.
2. Measurement Level = Reading Level + Correct Factor.
3. The average measurement was not performed when the peak measured data under the limit of average detection.

Product : Software defined radio
 Test Item : Band Edge
 Test Mode : Mode 2: Transmit_Patch (A1+ A2+ B1+ B2) (2462MHz)
 Test Date : 2019/01/09

Horizontal

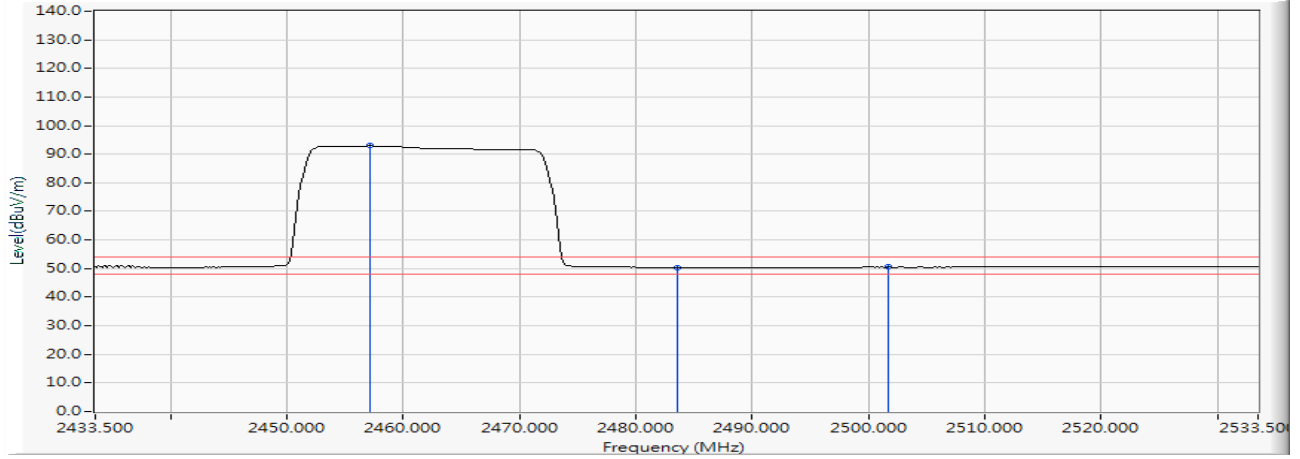

		Frequency (MHz)	Correct Factor (dB)	Reading Level (dBµV)	Measure Level (dBµV/m)	Margin (dB)	Limit (dBµV/m)	Detector Type
1	*	2457.123	36.595	56.305	92.900	--	--	AVERAGE
2		2483.500	36.686	13.727	50.413	-3.587	54.000	AVERAGE
3		2501.761	36.739	13.765	50.505	-3.495	54.000	AVERAGE

Note:

1. All readings above 1GHz are performed with peak and/or average measurements as necessary.
2. Measurement Level = Reading Level + Correct Factor.
3. The average measurement was not performed when the peak measured data under the limit of average detection.

Product : Software defined radio
 Test Item : Band Edge
 Test Mode : Mode 2: Transmit_Patch (A1+ A2+ B1+ B2) (2462MHz)
 Test Date : 2019/01/09

Vertical

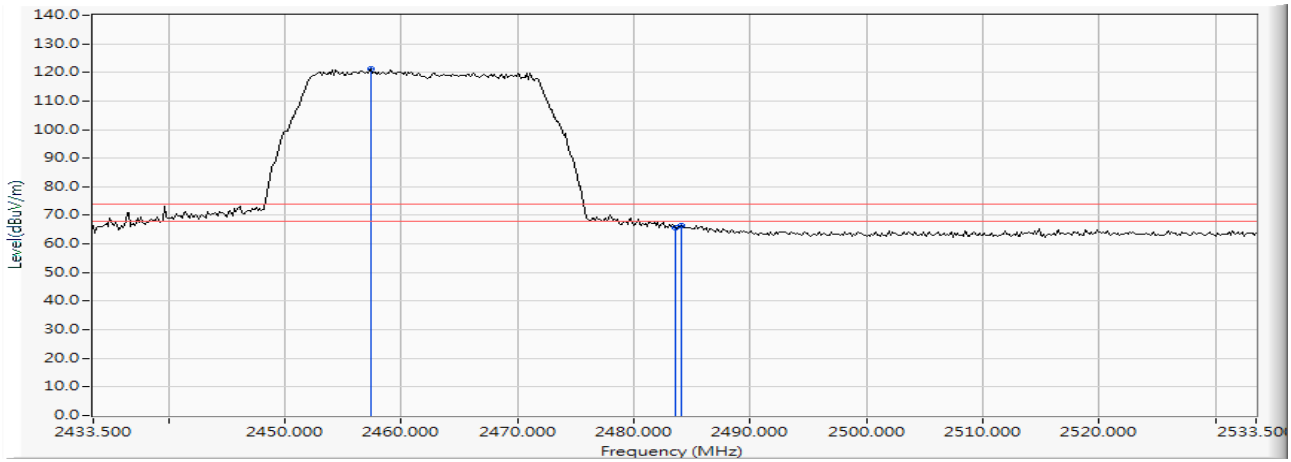

		Frequency (MHz)	Correct Factor (dB)	Reading Level (dBµV)	Measure Level (dBµV/m)	Margin (dB)	Limit (dBµV/m)	Detector Type
1	*	2457.413	36.597	84.779	121.375	--	--	PEAK
2		2483.500	36.686	29.028	65.714	-8.286	74.000	PEAK
3		2484.080	36.687	29.647	66.334	-7.666	74.000	PEAK

Note:

1. All readings above 1GHz are performed with peak and/or average measurements as necessary.
2. Measurement Level = Reading Level + Correct Factor.
3. The average measurement was not performed when the peak measured data under the limit of average detection.

Product : Software defined radio
 Test Item : Band Edge
 Test Mode : Mode 2: Transmit_Patch (A1+ A2+ B1+ B2) (2462MHz)
 Test Date : 2019/01/09

Vertical

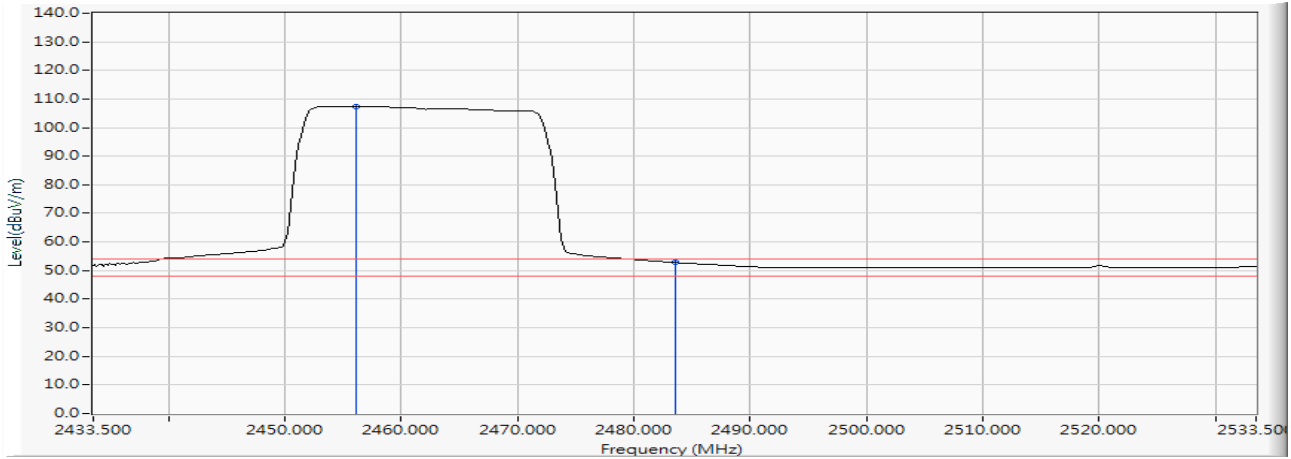

		Frequency (MHz)	Correct Factor (dB)	Reading Level (dBµV)	Measure Level (dBµV/m)	Margin (dB)	Limit (dBµV/m)	Detector Type
1	*	2456.109	36.590	70.810	107.399	--	--	AVERAGE
2		2483.500	36.686	16.124	52.810	-1.190	54.000	AVERAGE

Note:

1. All readings above 1GHz are performed with peak and/or average measurements as necessary.
2. Measurement Level = Reading Level + Correct Factor.
3. The average measurement was not performed when the peak measured data under the limit of average detection.

Product : Software defined radio
 Test Item : Band Edge
 Test Mode : Mode 2: Transmit_Patch (B1+ B2) (2412MHz)
 Test Date : 2019/01/09

Horizontal

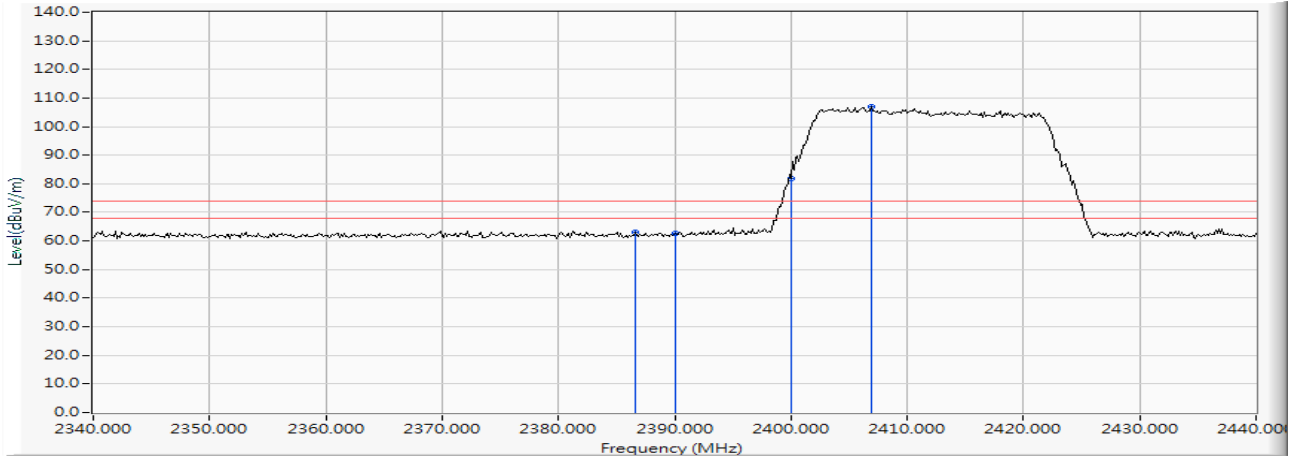

		Frequency (MHz)	Correct Factor (dB)	Reading Level (dBµV)	Measure Level (dBµV/m)	Margin (dB)	Limit (dBµV/m)	Detector Type
1		2386.667	36.441	26.434	62.874	-11.126	74.000	PEAK
2		2390.000	36.456	26.080	62.536	-11.464	74.000	PEAK
3		2400.000	36.503	45.505	82.008	--	--	PEAK
4	*	2406.957	36.517	70.576	107.093	--	--	PEAK

Note:

1. All readings above 1GHz are performed with peak and/or average measurements as necessary.
2. Measurement Level = Reading Level + Correct Factor.
3. The average measurement was not performed when the peak measured data under the limit of average detection.

Product : Software defined radio
 Test Item : Band Edge
 Test Mode : Mode 2: Transmit_Patch (B1+ B2) (2412MHz)
 Test Date : 2019/01/09

Horizontal

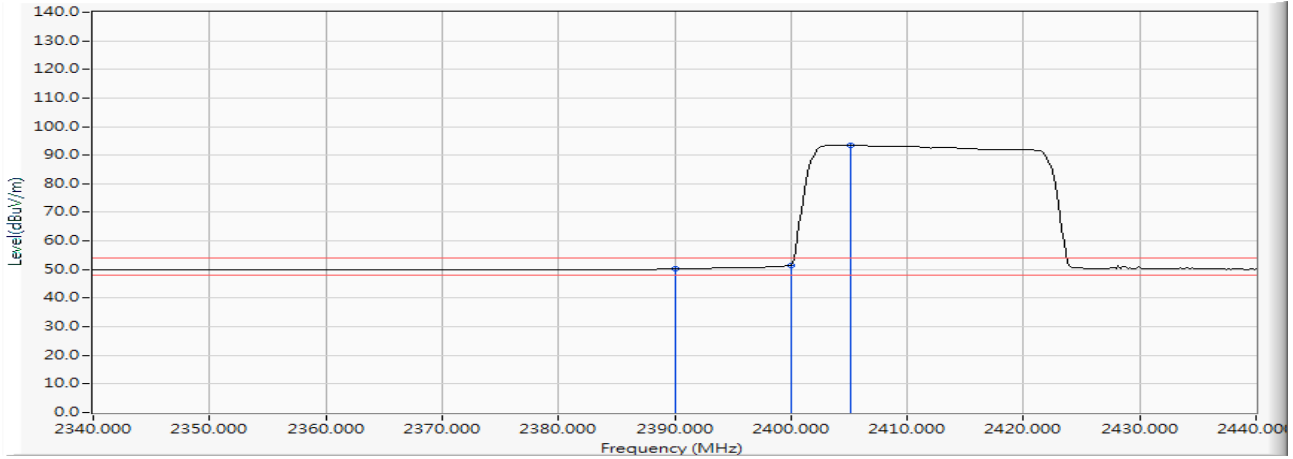

		Frequency (MHz)	Correct Factor (dB)	Reading Level (dBµV)	Measure Level (dBµV/m)	Margin (dB)	Limit (dBµV/m)	Detector Type
1		2390.000	36.456	13.771	50.227	-3.773	54.000	AVERAGE
2		2400.000	36.503	14.968	51.471	-2.529	54.000	AVERAGE
3	*	2405.072	36.515	56.869	93.384	--	--	AVERAGE

Note:

1. All readings above 1GHz are performed with peak and/or average measurements as necessary.
2. Measurement Level = Reading Level + Correct Factor.
3. The average measurement was not performed when the peak measured data under the limit of average detection.

Product : Software defined radio
 Test Item : Band Edge
 Test Mode : Mode 2: Transmit_Patch (B1+ B2) (2412MHz)
 Test Date : 2019/01/09

Vertical

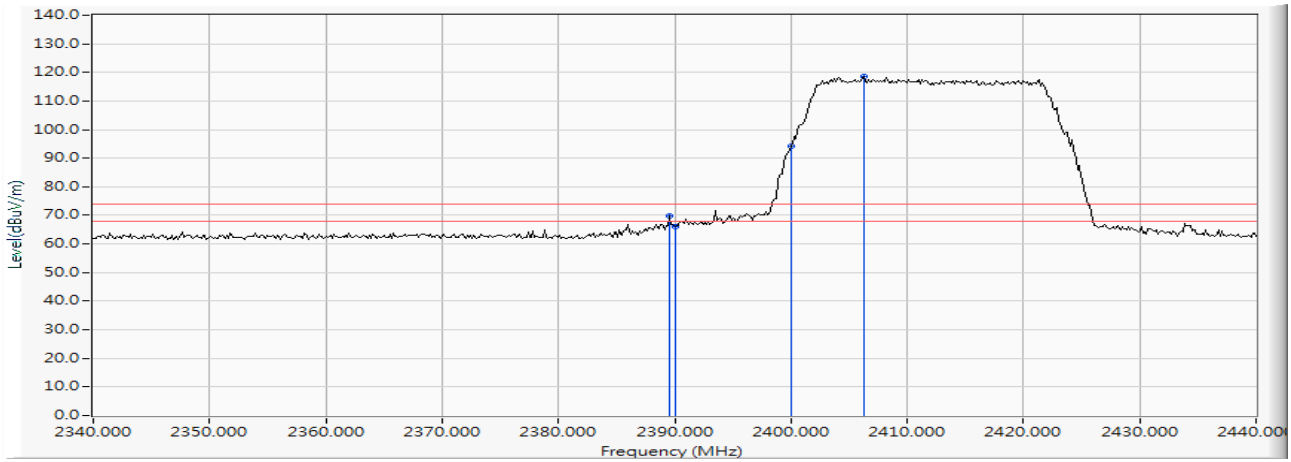

		Frequency (MHz)	Correct Factor (dB)	Reading Level (dBµV)	Measure Level (dBµV/m)	Margin (dB)	Limit (dBµV/m)	Detector Type
1		2389.565	36.454	33.418	69.872	-4.128	74.000	PEAK
2		2390.000	36.456	29.453	65.909	-8.091	74.000	PEAK
3		2400.000	36.503	57.534	94.037	--	--	PEAK
4	*	2406.232	36.517	82.209	118.725	--	--	PEAK

Note:

1. All readings above 1GHz are performed with peak and/or average measurements as necessary.
2. Measurement Level = Reading Level + Correct Factor.
3. The average measurement was not performed when the peak measured data under the limit of average detection.

Product : Software defined radio
 Test Item : Band Edge
 Test Mode : Mode 2: Transmit_Patch (B1+ B2) (2412MHz)
 Test Date : 2019/01/09

Vertical

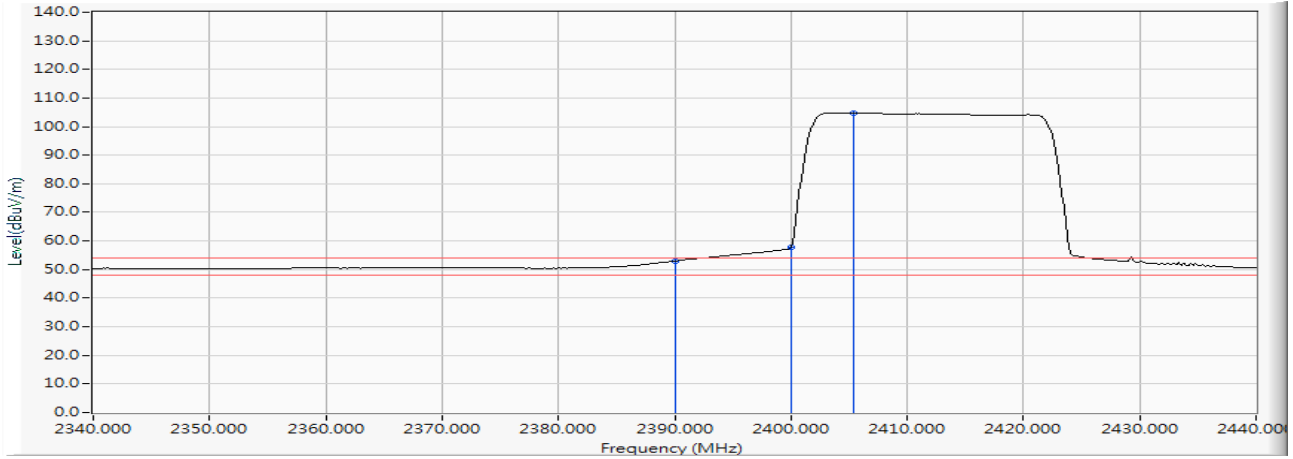

		Frequency (MHz)	Correct Factor (dB)	Reading Level (dBµV)	Measure Level (dBµV/m)	Margin (dB)	Limit (dBµV/m)	Detector Type
1		2390.000	36.456	16.560	53.016	-0.984	54.000	AVERAGE
2		2400.000	36.503	21.253	57.756	3.756	54.000	AVERAGE
3	*	2405.362	36.515	68.190	104.706	--	--	AVERAGE

Note:

1. All readings above 1GHz are performed with peak and/or average measurements as necessary.
2. Measurement Level = Reading Level + Correct Factor.
3. The average measurement was not performed when the peak measured data under the limit of average detection.

Product : Software defined radio
 Test Item : Band Edge
 Test Mode : Mode 2: Transmit_Patch (B1+ B2) (2462MHz)
 Test Date : 2019/01/09

Horizontal

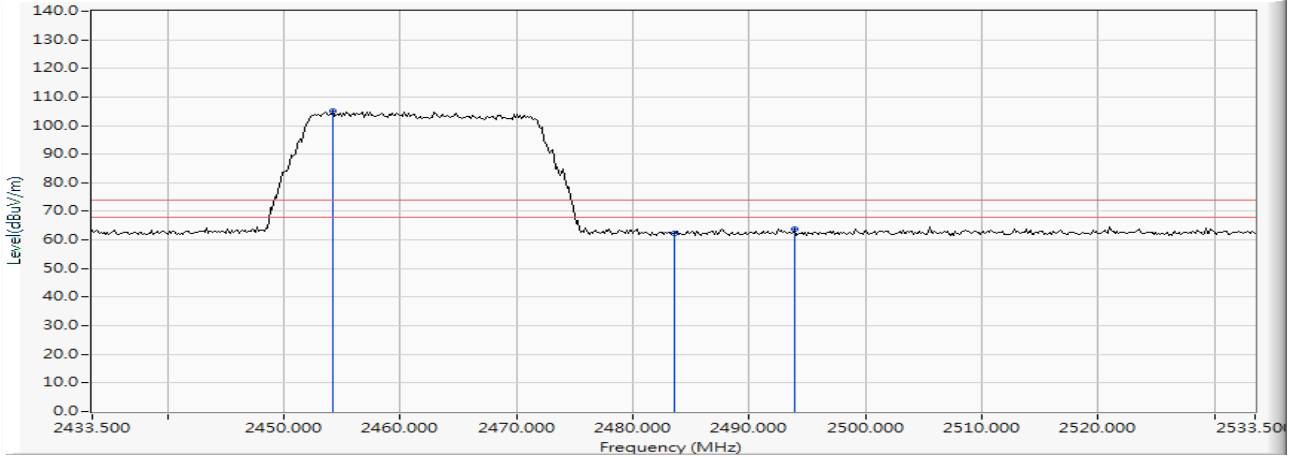

		Frequency (MHz)	Correct Factor (dB)	Reading Level (dBµV)	Measure Level (dBµV/m)	Margin (dB)	Limit (dBµV/m)	Detector Type
1	*	2454.225	36.590	68.537	105.127	--	--	PEAK
2		2483.500	36.686	25.521	62.207	-11.793	74.000	PEAK
3		2493.935	36.699	26.987	63.686	-10.314	74.000	PEAK

Note:

1. All readings above 1GHz are performed with peak and/or average measurements as necessary.
2. Measurement Level = Reading Level + Correct Factor.
3. The average measurement was not performed when the peak measured data under the limit of average detection.

Product : Software defined radio
 Test Item : Band Edge
 Test Mode : Mode 2: Transmit_Patch (B1+ B2) (2462MHz)
 Test Date : 2019/01/09

Horizontal

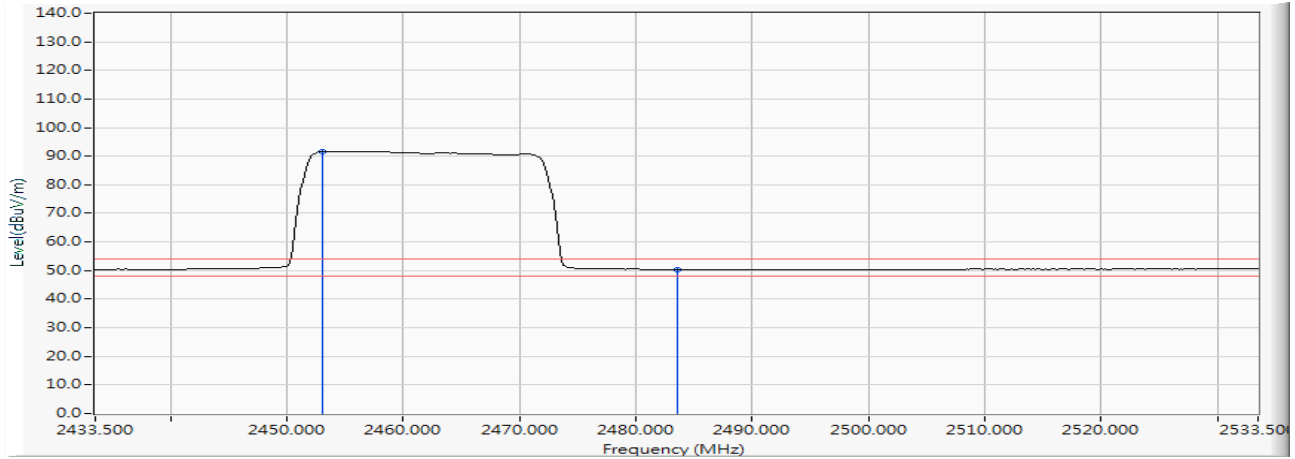

		Frequency (MHz)	Correct Factor (dB)	Reading Level (dBµV)	Measure Level (dBµV/m)	Margin (dB)	Limit (dBµV/m)	Detector Type
1	*	2453.065	36.590	55.096	91.687	--	--	AVERAGE
2		2483.500	36.686	13.720	50.406	-3.594	54.000	AVERAGE

Note:

1. All readings above 1GHz are performed with peak and/or average measurements as necessary.
2. Measurement Level = Reading Level + Correct Factor.
3. The average measurement was not performed when the peak measured data under the limit of average detection.

Product : Software defined radio
 Test Item : Band Edge
 Test Mode : Mode 2: Transmit_Patch (B1+ B2) (2462MHz)
 Test Date : 2019/01/09

Vertical

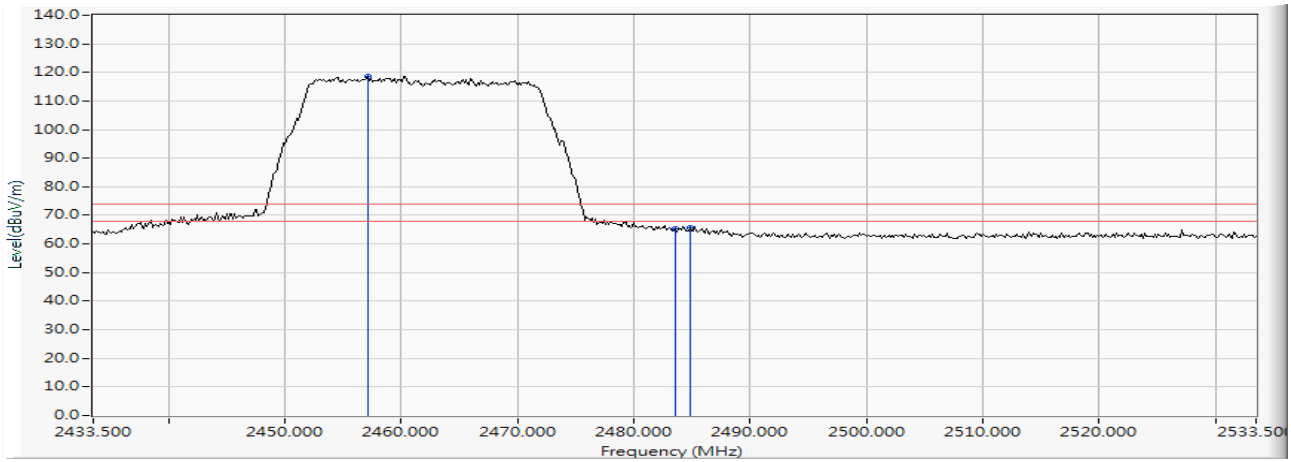

		Frequency (MHz)	Correct Factor (dB)	Reading Level (dBµV)	Measure Level (dBµV/m)	Margin (dB)	Limit (dBµV/m)	Detector Type
1	*	2457.123	36.595	82.138	118.733	--	--	PEAK
2		2483.500	36.686	28.663	65.349	-8.651	74.000	PEAK
3		2484.804	36.687	29.034	65.721	-8.279	74.000	PEAK

Note:

1. All readings above 1GHz are performed with peak and/or average measurements as necessary.
2. Measurement Level = Reading Level + Correct Factor.
3. The average measurement was not performed when the peak measured data under the limit of average detection.

Product : Software defined radio
 Test Item : Band Edge
 Test Mode : Mode 2: Transmit_Patch (B1+ B2) (2462MHz)
 Test Date : 2019/01/09

Vertical

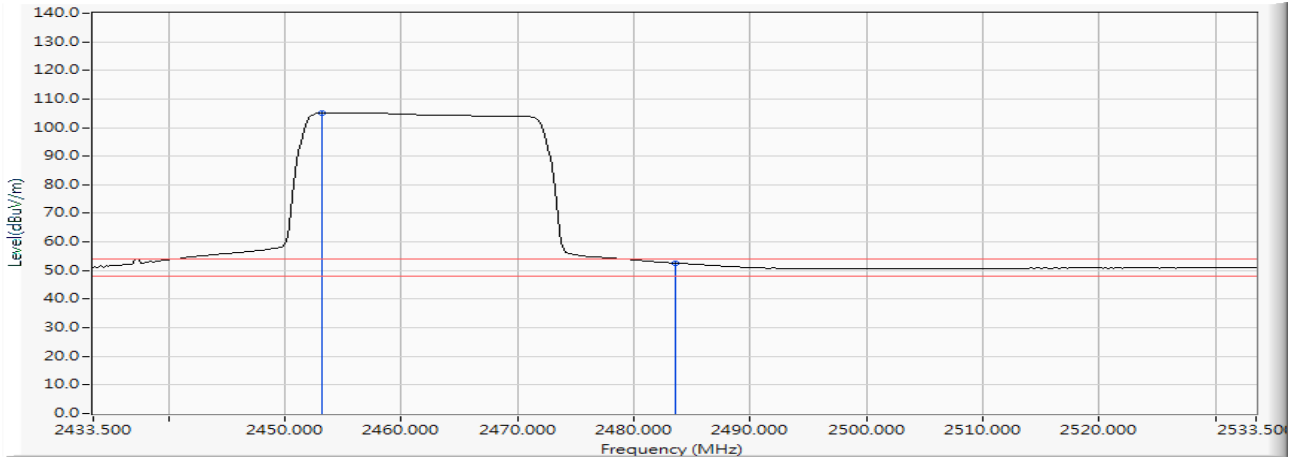

		Frequency (MHz)	Correct Factor (dB)	Reading Level (dBµV)	Measure Level (dBµV/m)	Margin (dB)	Limit (dBµV/m)	Detector Type
1	*	2453.210	36.591	68.551	105.142	--	--	AVERAGE
2		2483.500	36.686	15.919	52.605	-1.395	54.000	AVERAGE

Note:

1. All readings above 1GHz are performed with peak and/or average measurements as necessary.
2. Measurement Level = Reading Level + Correct Factor.
3. The average measurement was not performed when the peak measured data under the limit of average detection.

7. 6dB Bandwidth

7.1. Test Setup

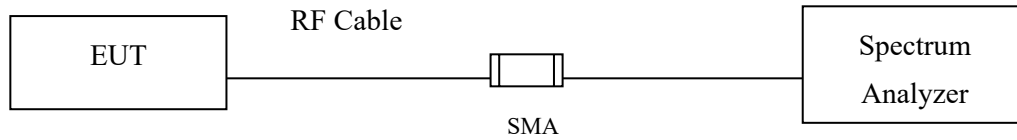

7.2. Limits

The minimum bandwidth shall be at least 500 kHz.

7.3. Test Procedure

Tested according to DTS test procedure of KDB558074 section 8.2 for compliance to FCC 47CFR 15.247 requirements.

Set RBW = 1-5% of the emission bandwidth, $VBW \geq 3 * RBW$

7.4. Uncertainty

$\pm 279.2\text{Hz}$

7.5. Test Result of 6dB Bandwidth

Product : Software defined radio
Test Item : 6dB Bandwidth Data
Test Mode : Mode 1: Transmit_Dipole (A1+ A2)

Channel No.	Frequency (MHz)	Chain	Measure Level (kHz)	Limit (kHz)	Result
01	2412	A1	19950	>500	Pass
06	2437	A1	19950	>500	Pass
11	2462	A1	20000	>500	Pass
01	2412	A2	20100	>500	Pass
06	2437	A2	20100	>500	Pass
11	2462	A2	20050	>500	Pass

Figure Channel 01 (Chain A1)

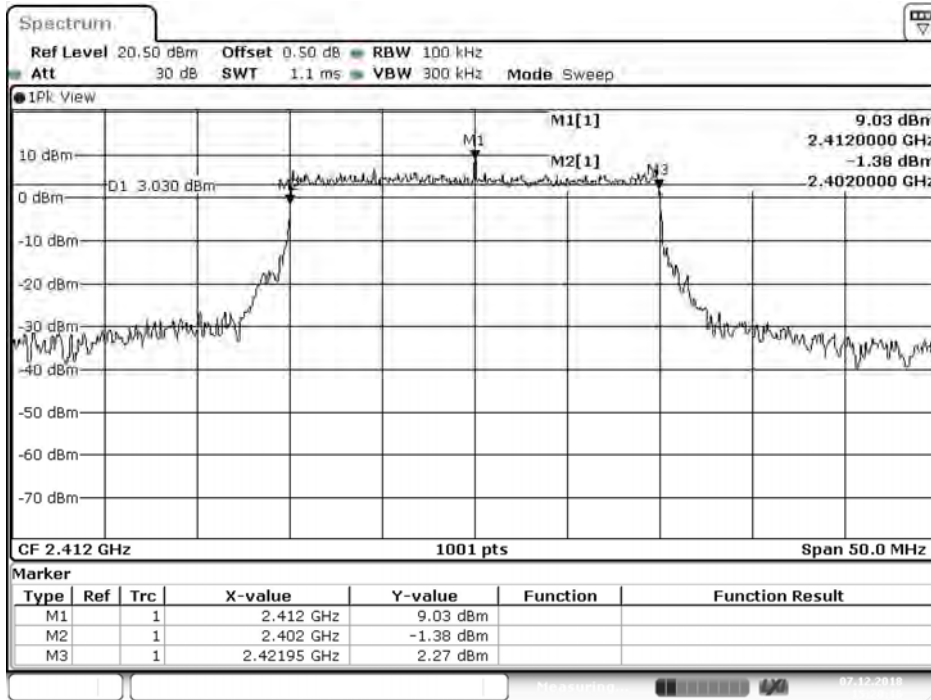

Date: 7.DEC.2018 15:20:16

Figure Channel 01 (Chain A2)

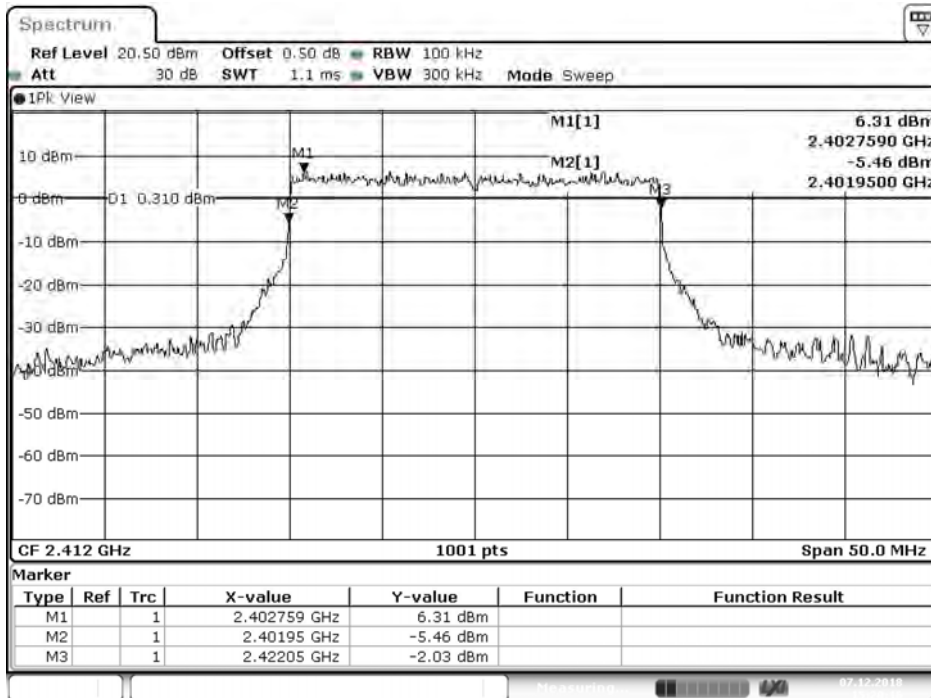

Date: 7.DEC.2018 15:20:16

Figure Channel 06 (Chain A1)

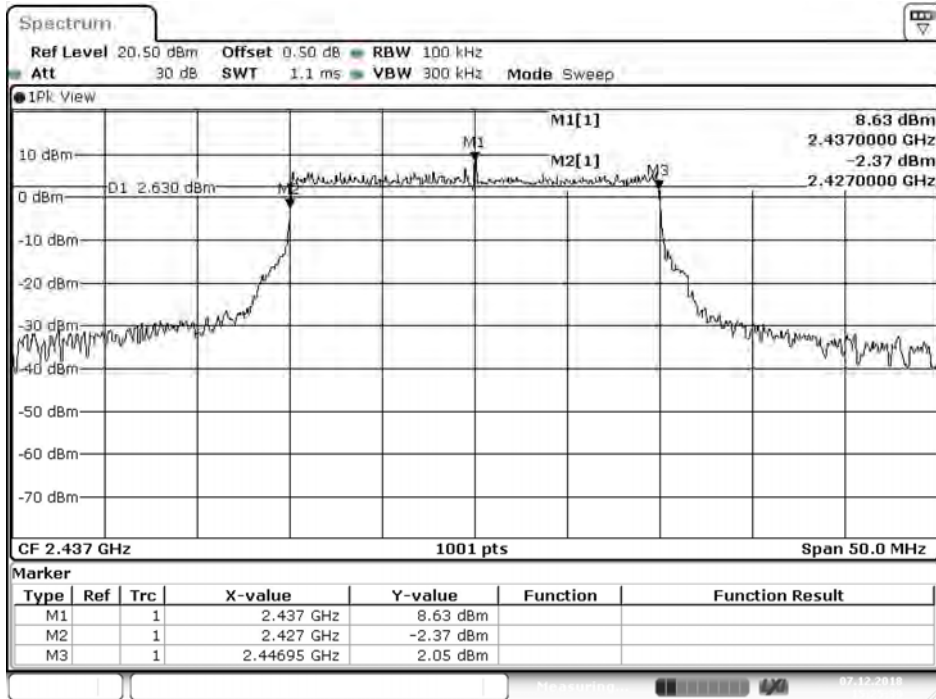

Date: 7.DEC.2018 15:25:40

Figure Channel 06 (Chain A2)

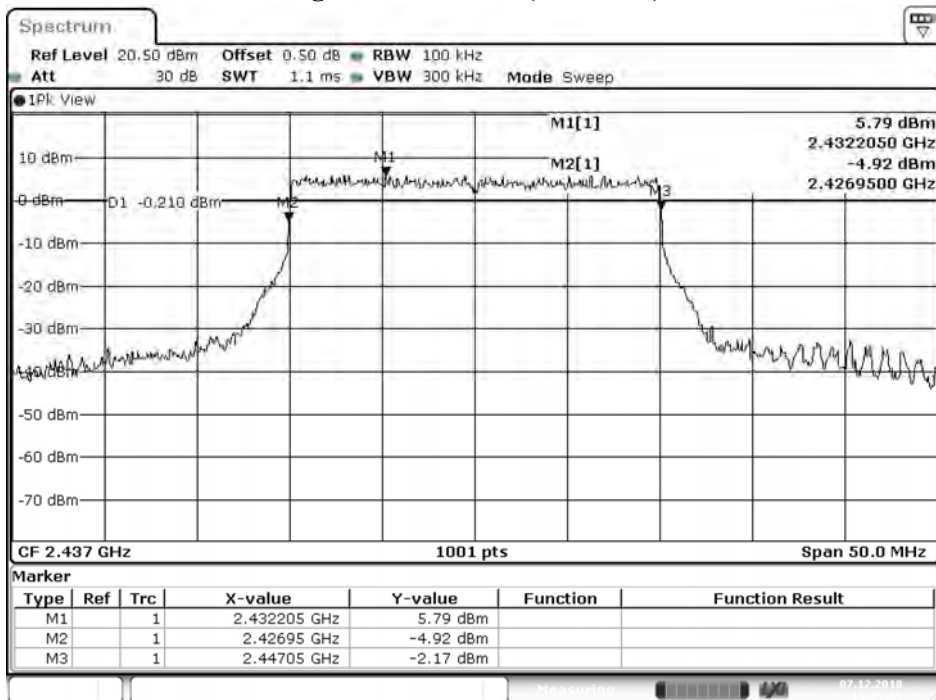

Date: 7.DEC.2018 15:25:39

Figure Channel 11 (Chain A1)

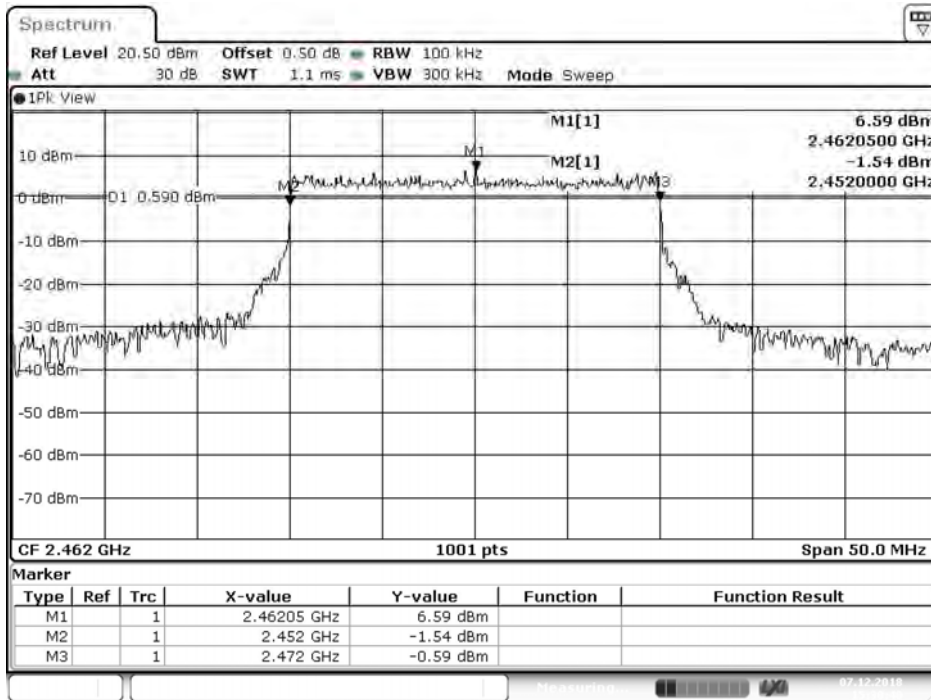

Date: 7.DEC.2018 15:30:40

Figure Channel 11 (Chain A2)

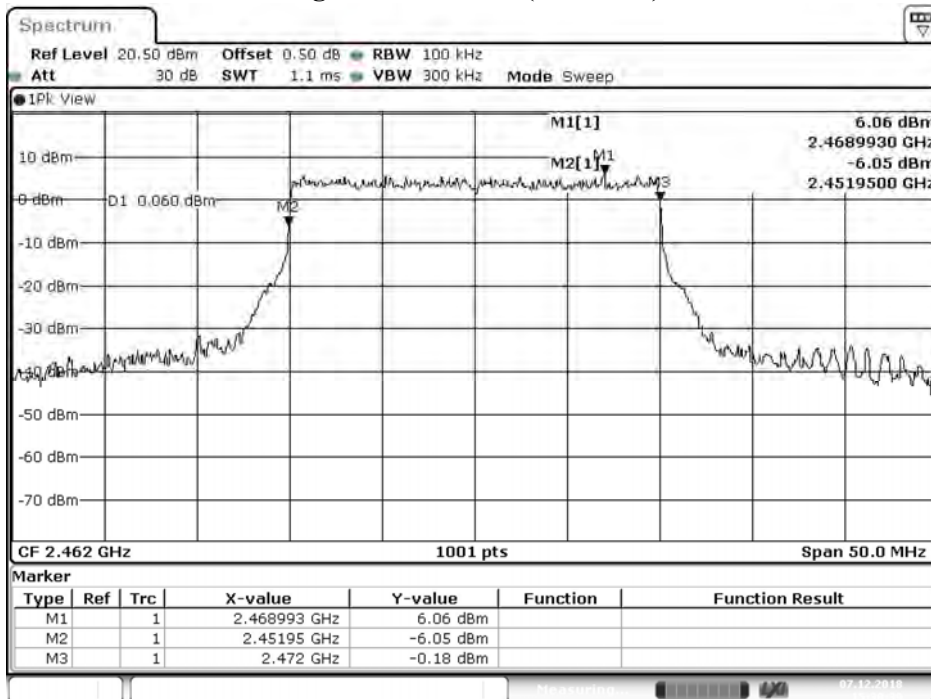

Date: 7.DEC.2018 15:30:40

Product : Software defined radio
Test Item : 6dB Bandwidth Data
Test Mode : Mode 1: Transmit_Dipole (A1+ A2+ B1+ B2)

Channel No.	Frequency (MHz)	Chain	Measure Level (kHz)	Limit (kHz)	Result
01	2412	A1	20000	>500	Pass
06	2437	A1	20000	>500	Pass
11	2462	A1	19950	>500	Pass
01	2412	A2	20100	>500	Pass
06	2437	A2	20050	>500	Pass
11	2462	A2	20050	>500	Pass
01	2412	B1	20000	>500	Pass
06	2437	B1	19950	>500	Pass
11	2462	B1	19950	>500	Pass
01	2412	B2	20100	>500	Pass
06	2437	B2	20000	>500	Pass
11	2462	B2	20100	>500	Pass

Figure Channel 01 (Chain A1)

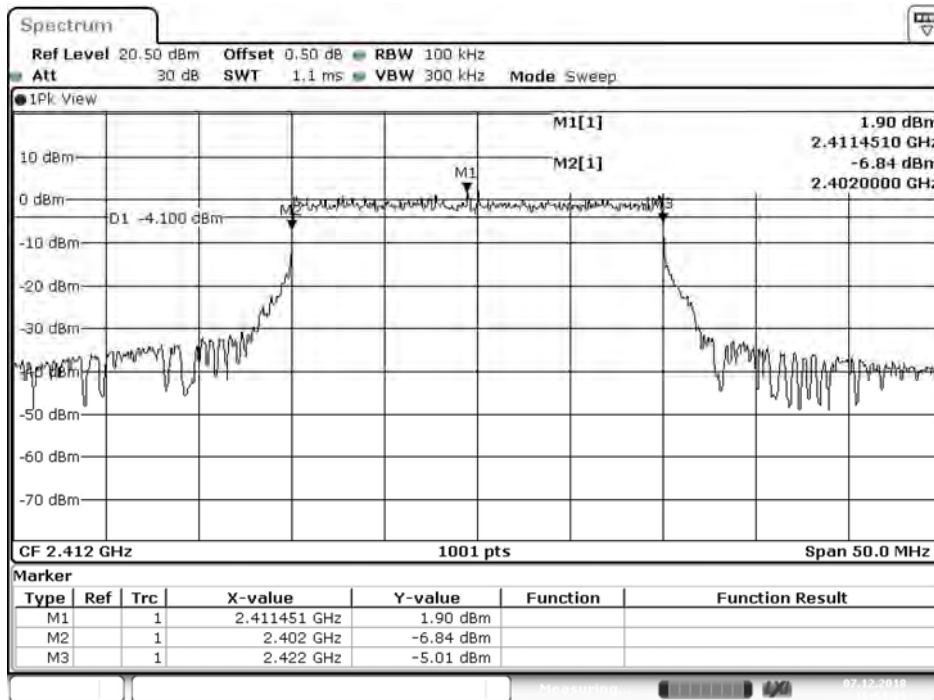

Figure Channel 01 (Chain A2)

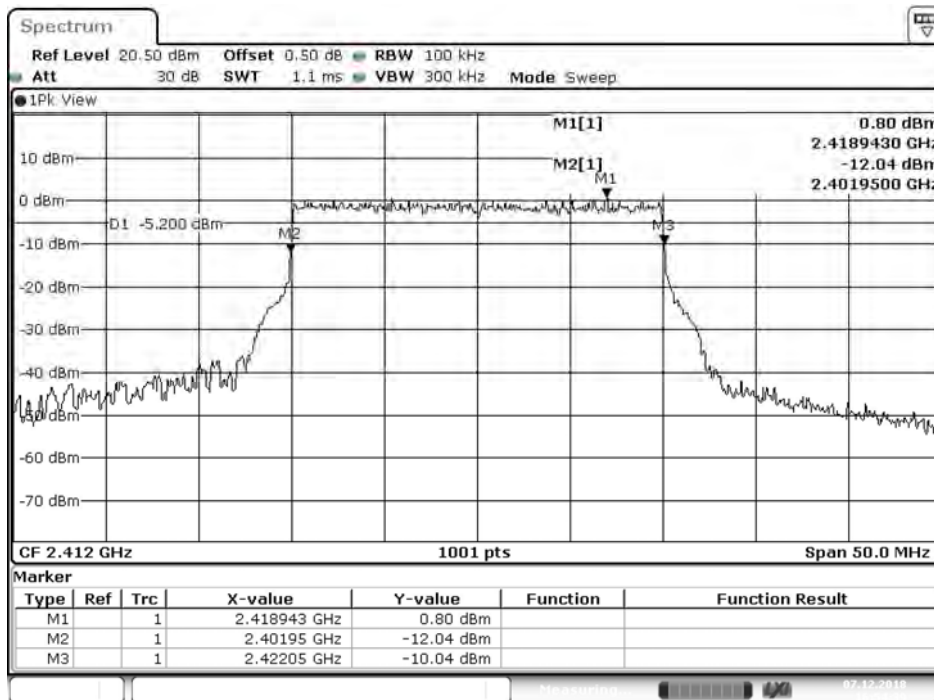

Figure Channel 01 (Chain B1)

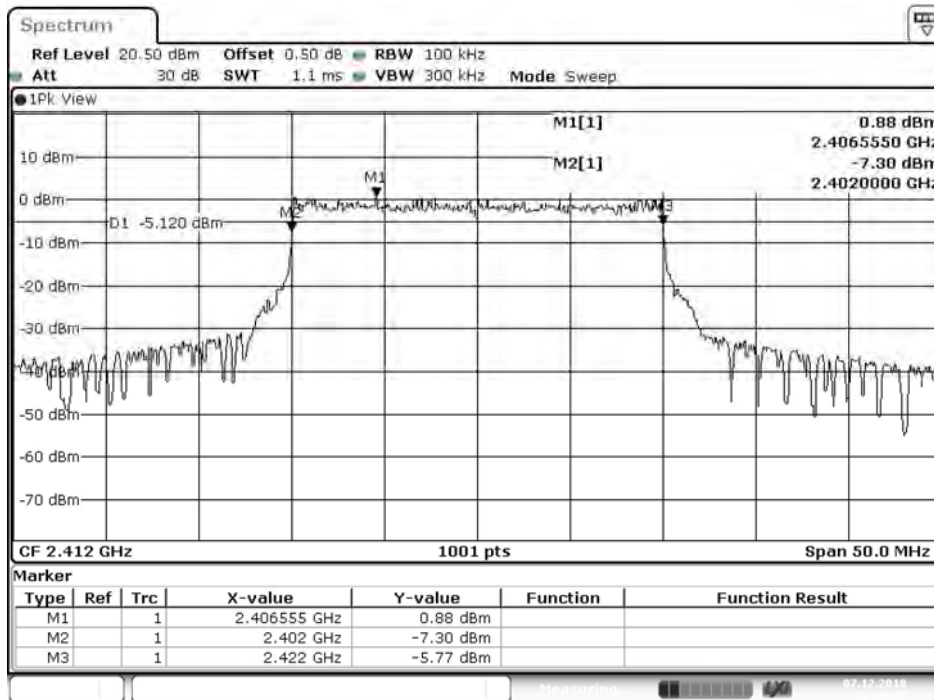

Figure Channel 01 (Chain B2)

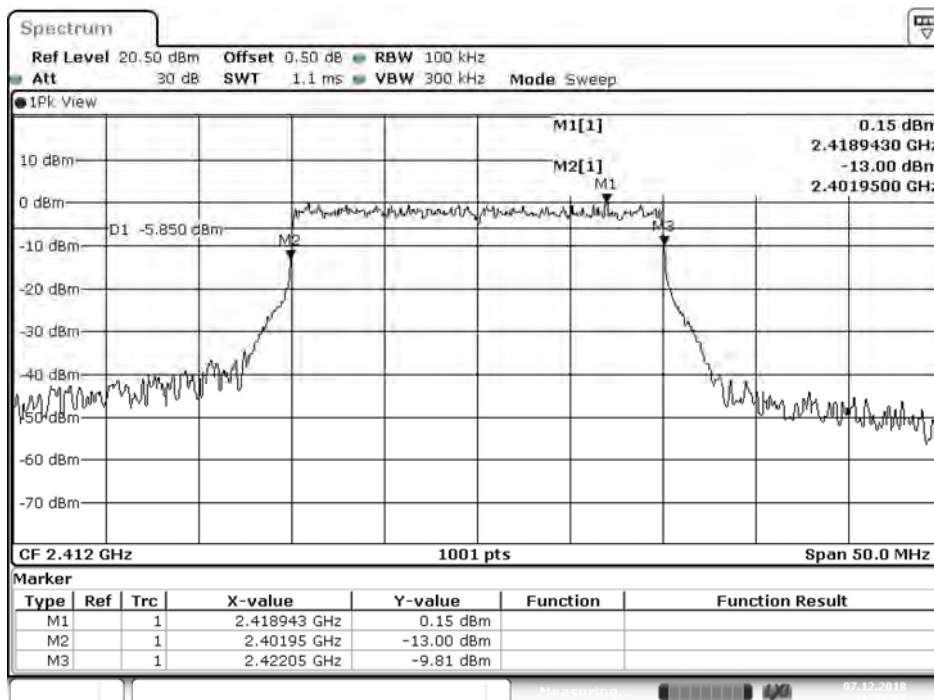
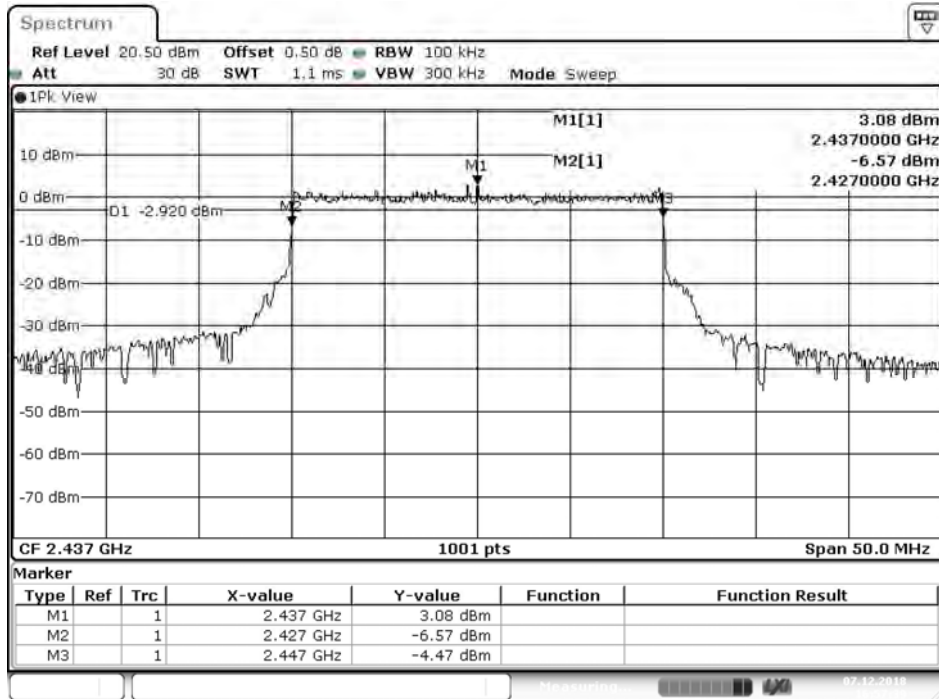
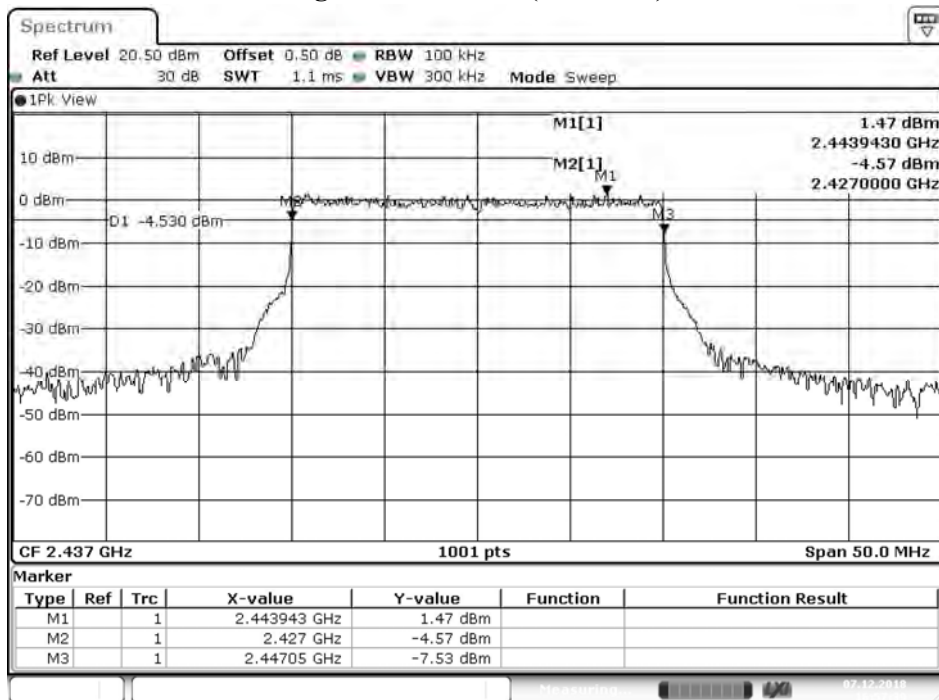

Figure Channel 06 (Chain A1)



Date: 7.DEC.2018 16:57:39

Figure Channel 06 (Chain A2)



Date: 7.DEC.2018 16:57:39

Figure Channel 06 (Chain B1)

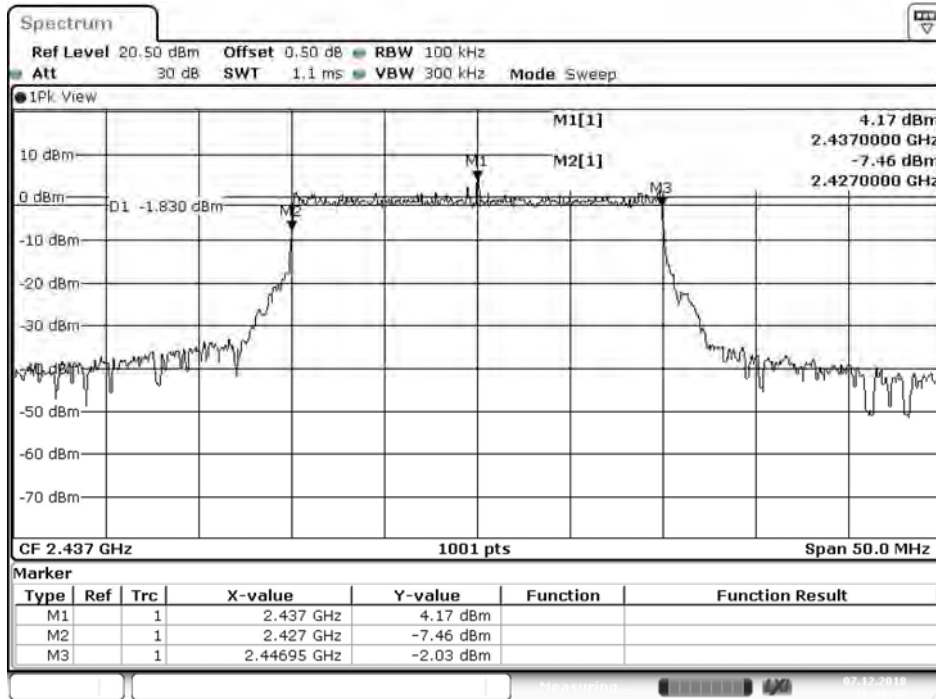

Date: 7.DEC.2018 16:38:46

Figure Channel 06 (Chain B2)

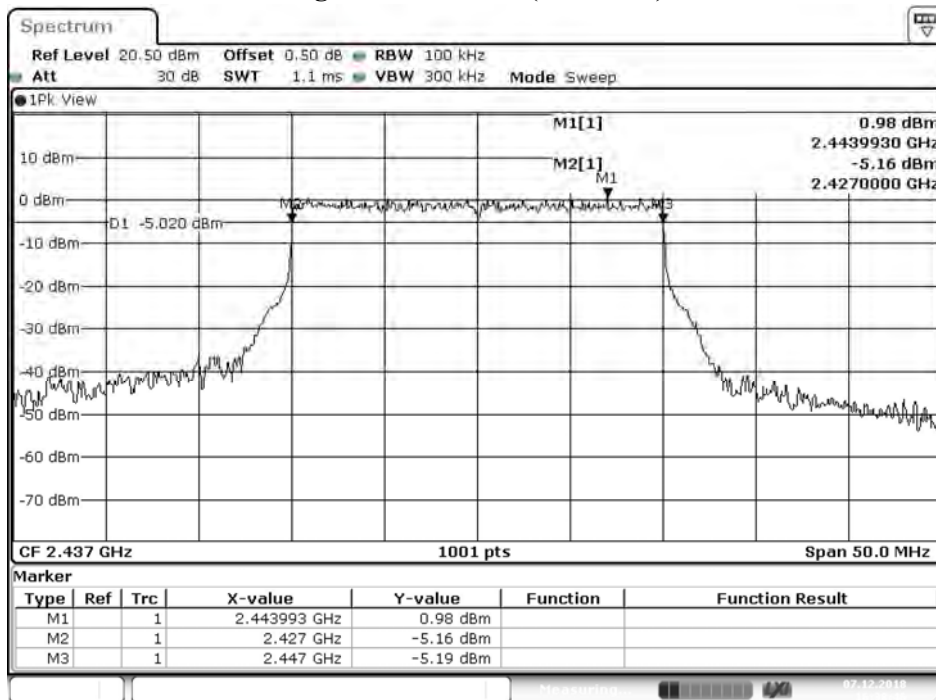

Date: 7.DEC.2018 16:38:46

Figure Channel 11 (Chain A1)

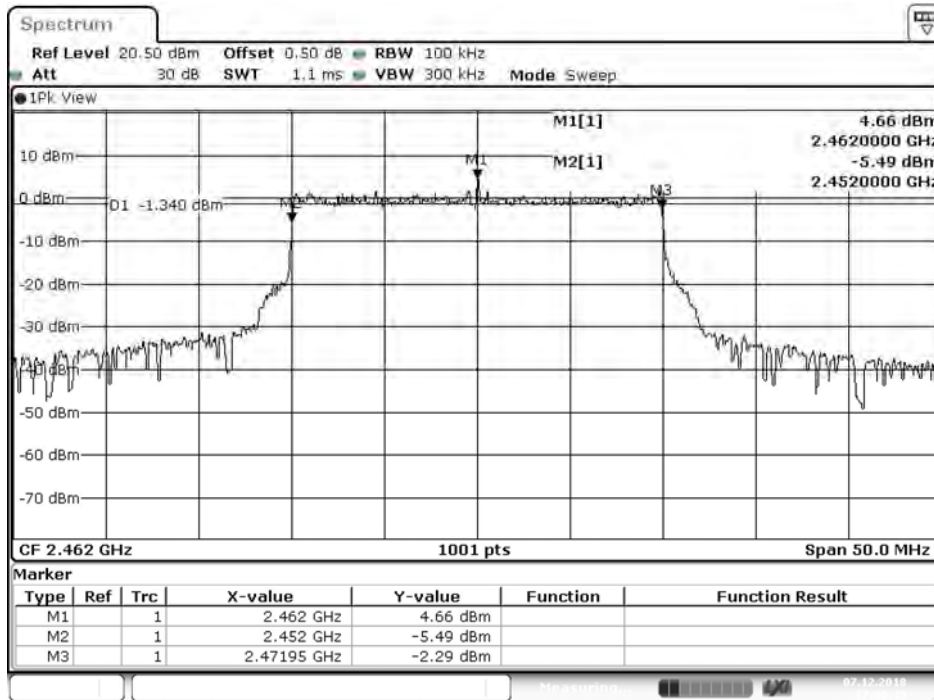

Date: 7.DEC.2018 17:00:46

Figure Channel 11 (Chain A2)

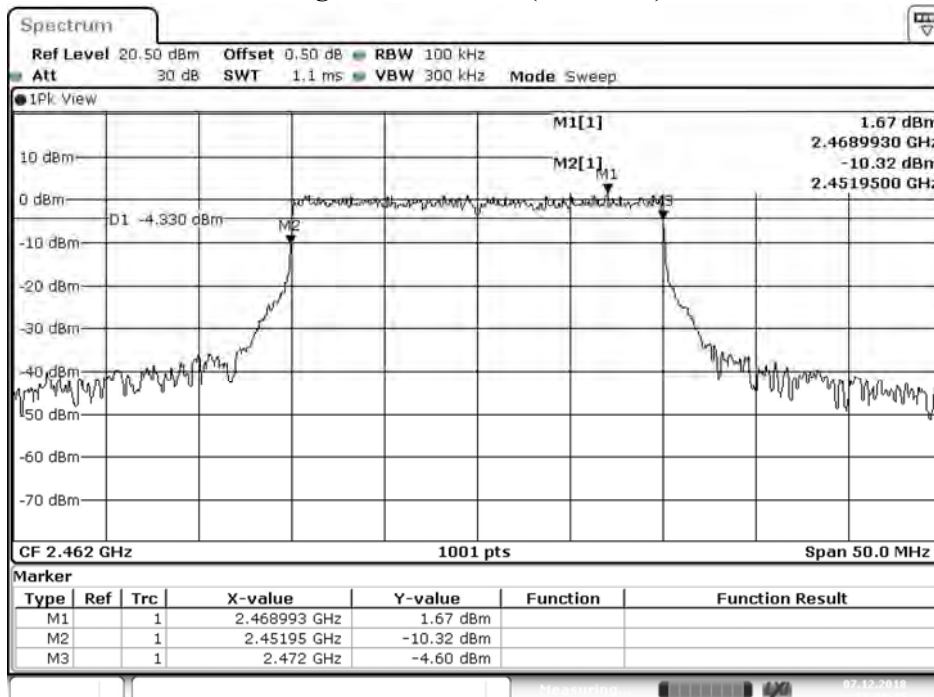

Date: 7.DEC.2018 17:00:45

Figure Channel 11 (Chain B1)

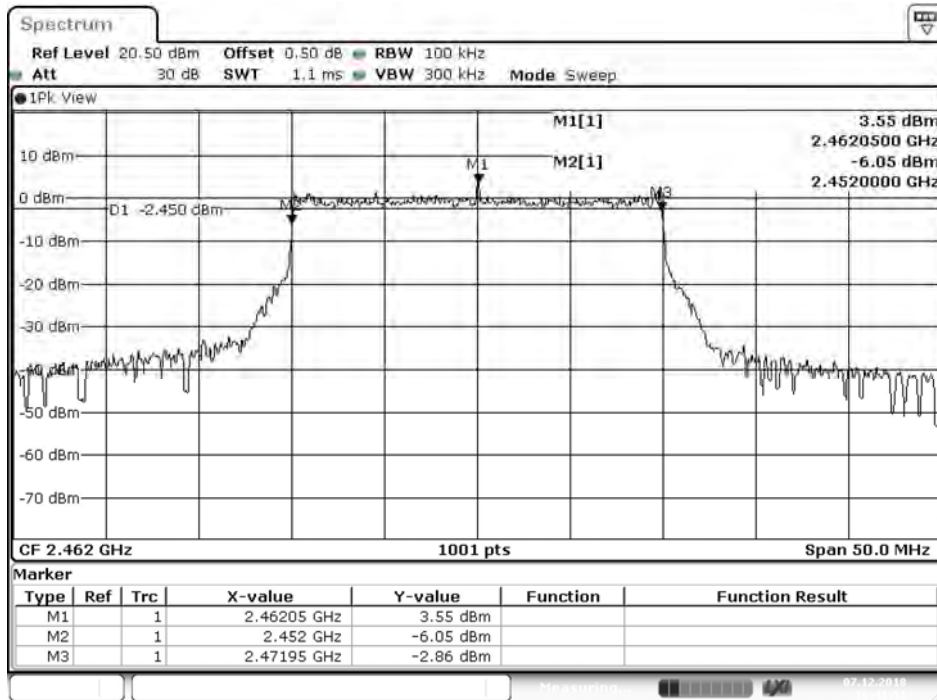

Date: 7.DEC.2018 16:41:52

Figure Channel 11 (Chain B2)

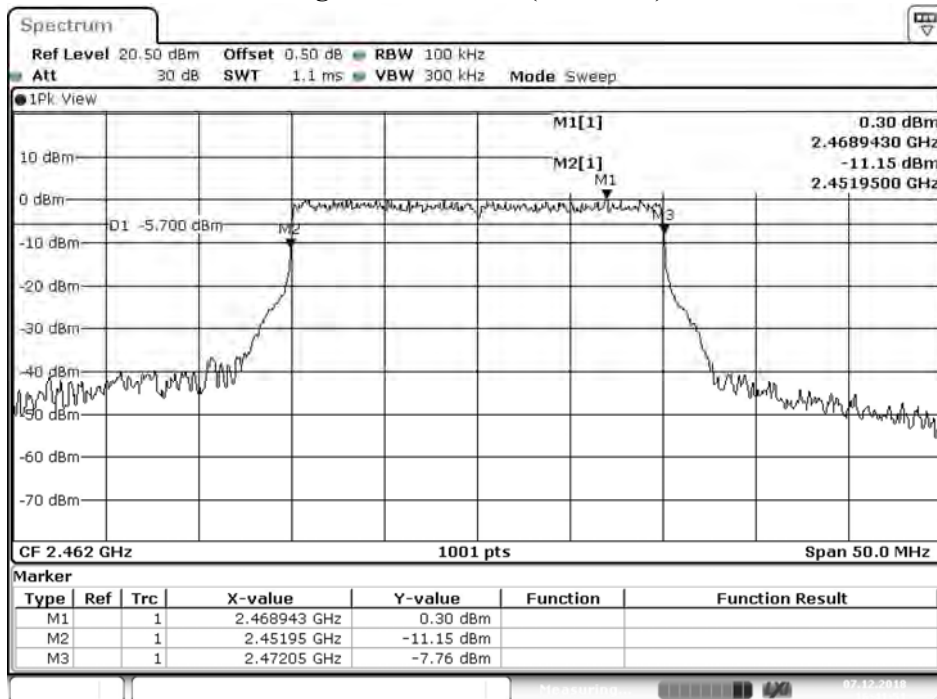

Date: 7.DEC.2018 16:41:52

Product : Software defined radio
Test Item : 6dB Bandwidth Data
Test Mode : Mode 1: Transmit_Dipole (B1+ B2)

Channel No.	Frequency (MHz)	Chain	Measure Level (kHz)	Limit (kHz)	Result
01	2412	B1	19950	>500	Pass
06	2437	B1	19900	>500	Pass
11	2462	B1	19850	>500	Pass
01	2412	B2	20000	>500	Pass
06	2437	B2	20100	>500	Pass
11	2462	B2	20100	>500	Pass

Figure Channel 01 (Chain B1)

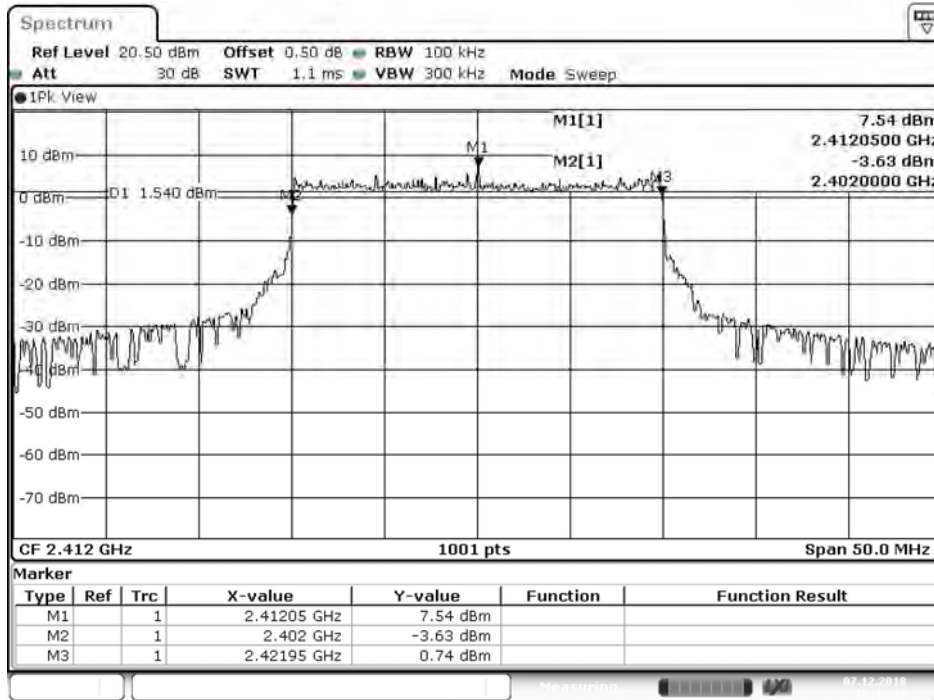

Date: 7.DEC.2018 15:43:37

Figure Channel 01 (Chain B2)

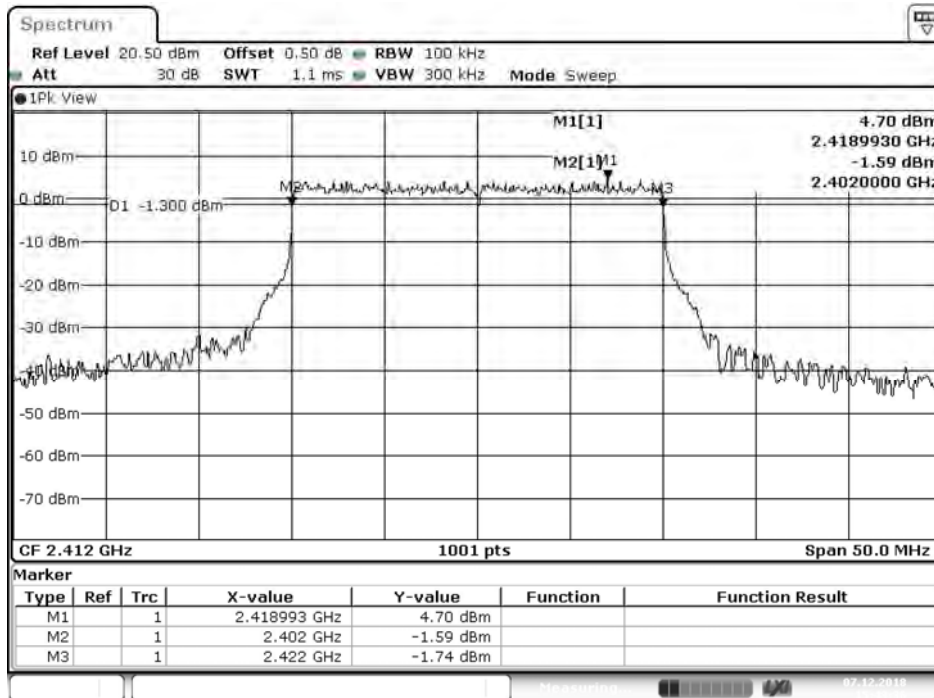

Date: 7.DEC.2018 15:43:36

Figure Channel 06 (Chain B1)

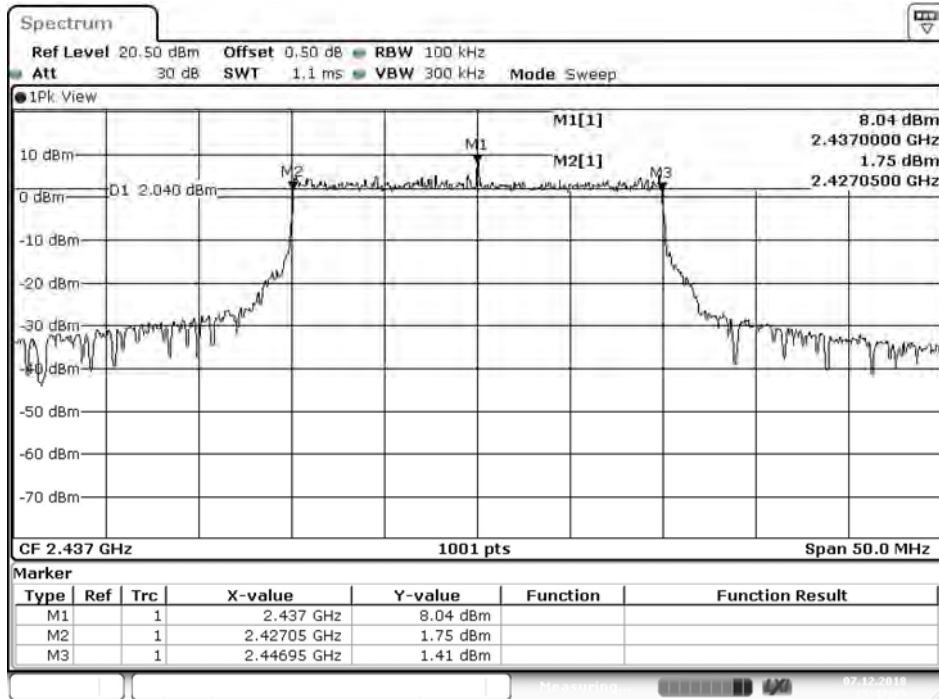

Date: 7.DEC.2018 15:47:36

Figure Channel 06 (Chain B2)

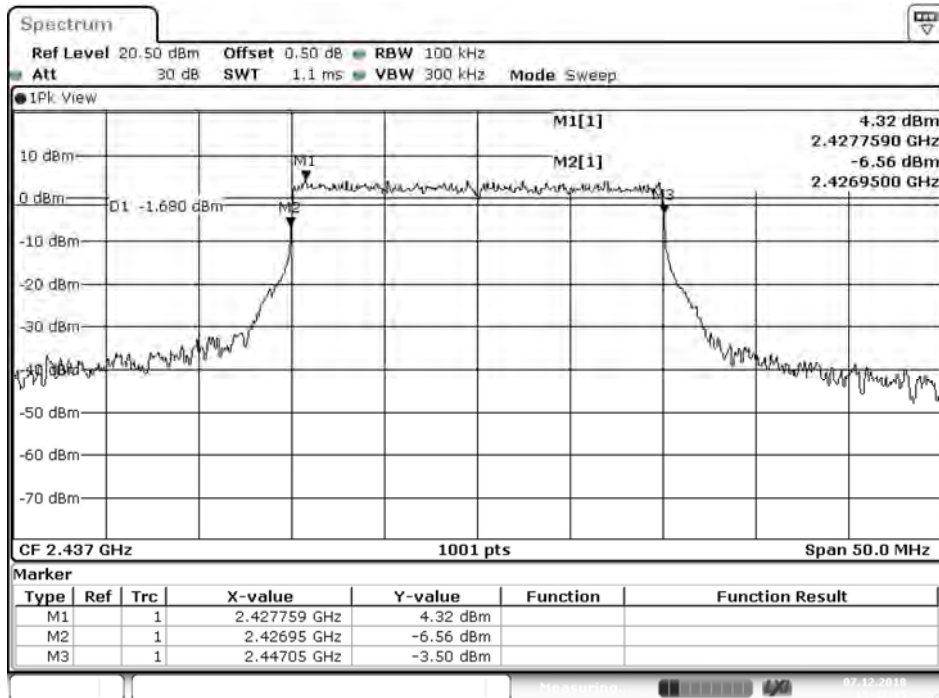

Date: 7.DEC.2018 15:47:36

Figure Channel 11 (Chain B1)

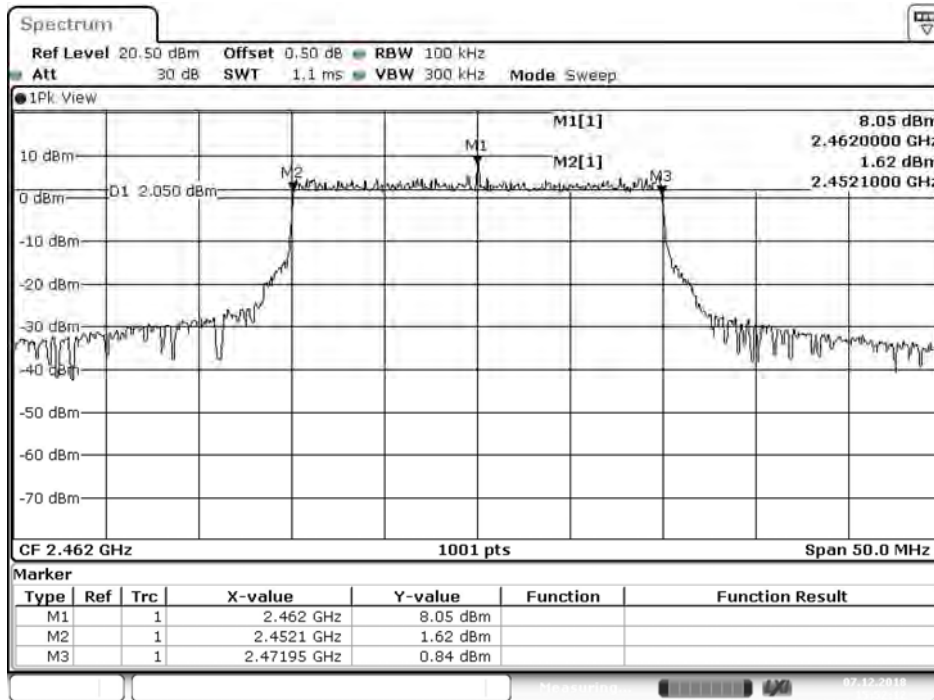
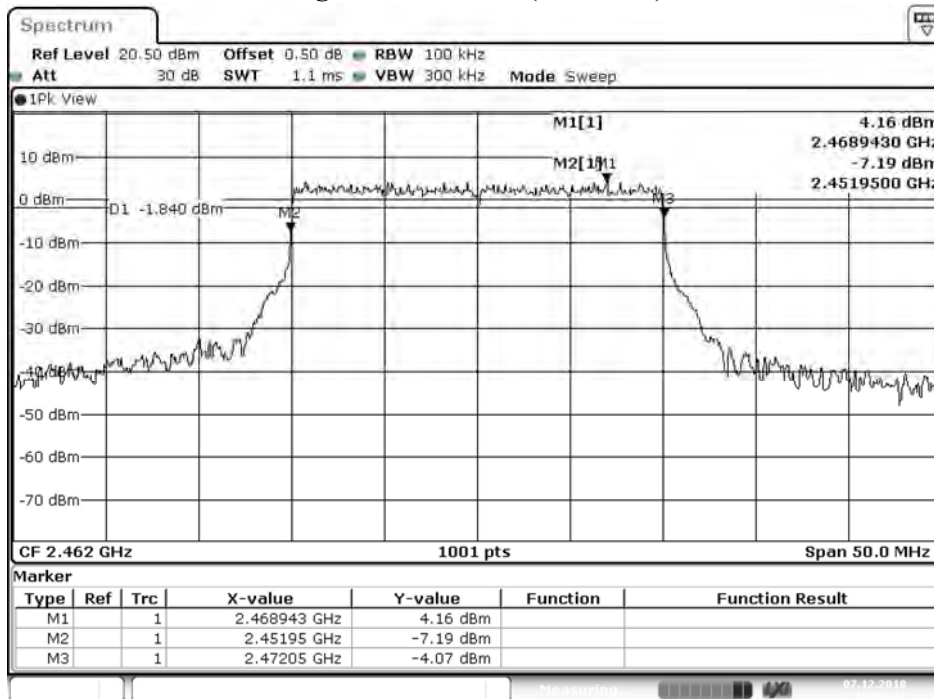

Figure Channel 11 (Chain B2)



Product : Software defined radio
Test Item : 6dB Bandwidth Data
Test Mode : Mode 2: Transmit_Patch (A1+ A2)

Channel No.	Frequency (MHz)	Chain	Measure Level (kHz)	Limit (kHz)	Result
01	2412	A1	19900	>500	Pass
06	2437	A1	19950	>500	Pass
11	2462	A1	19950	>500	Pass
01	2412	A2	20000	>500	Pass
06	2437	A2	20000	>500	Pass
11	2462	A2	20100	>500	Pass

Figure Channel 01 (Chain A1)

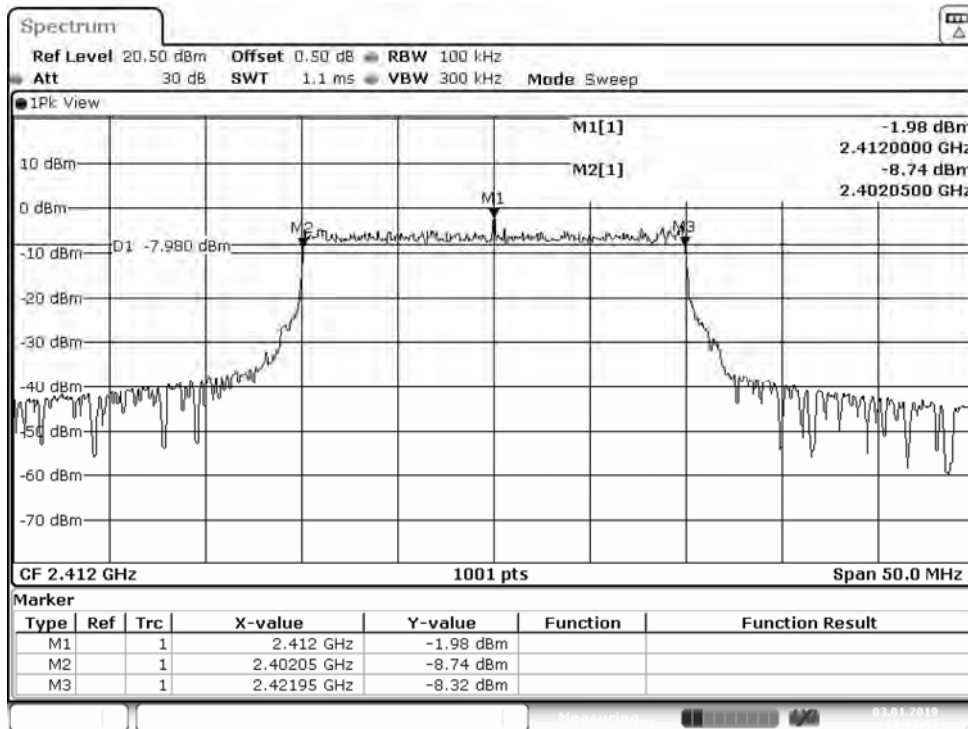
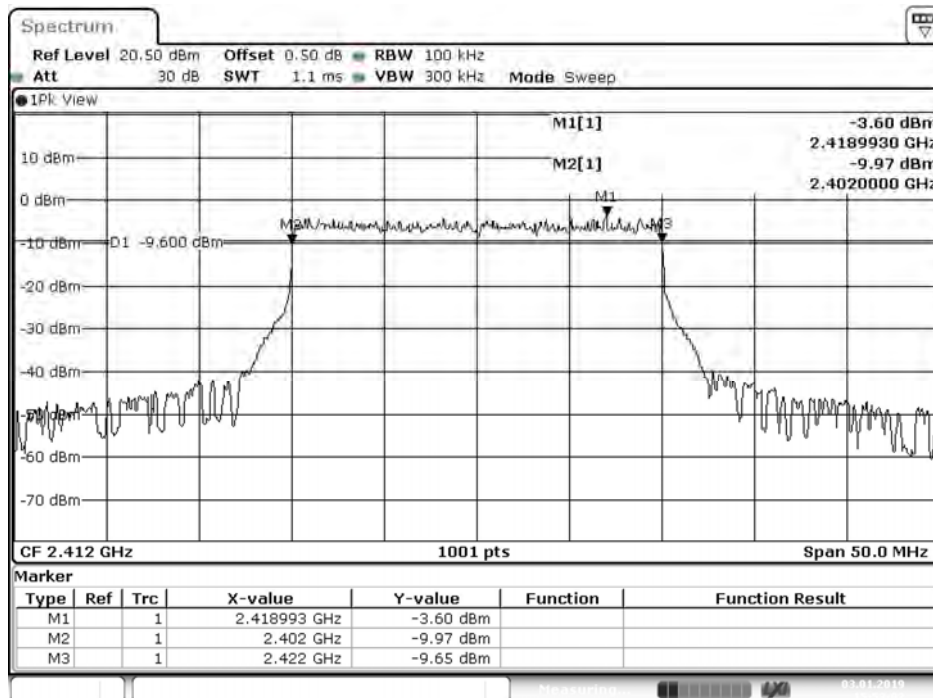

Figure Channel 01 (Chain A2)



Date: 3.JAN.2019 15:53:02

Figure Channel 06 (Chain A1)

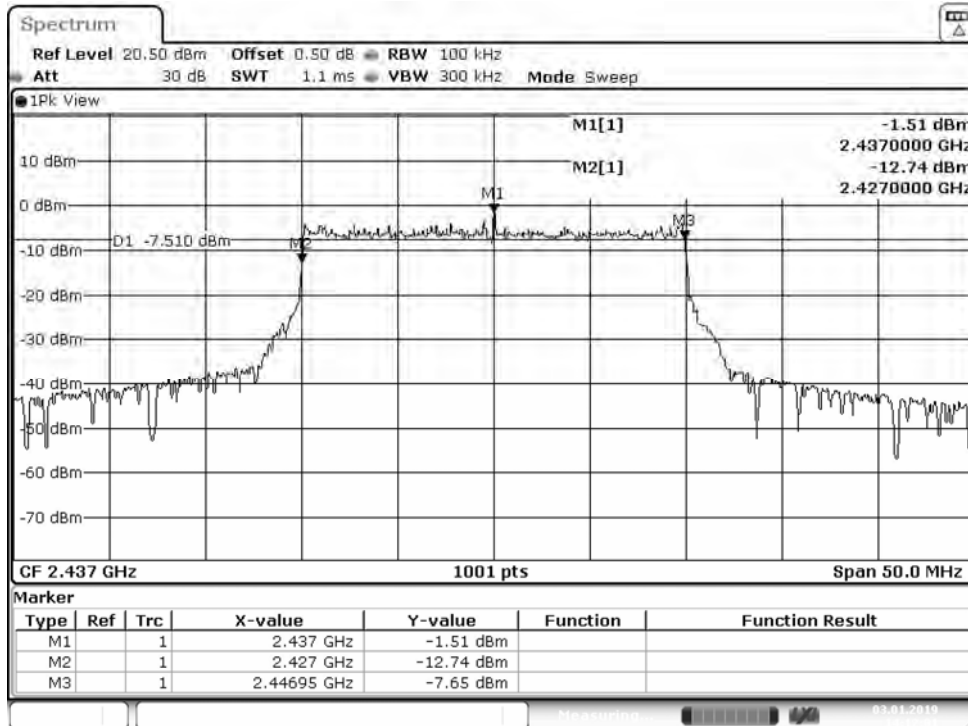
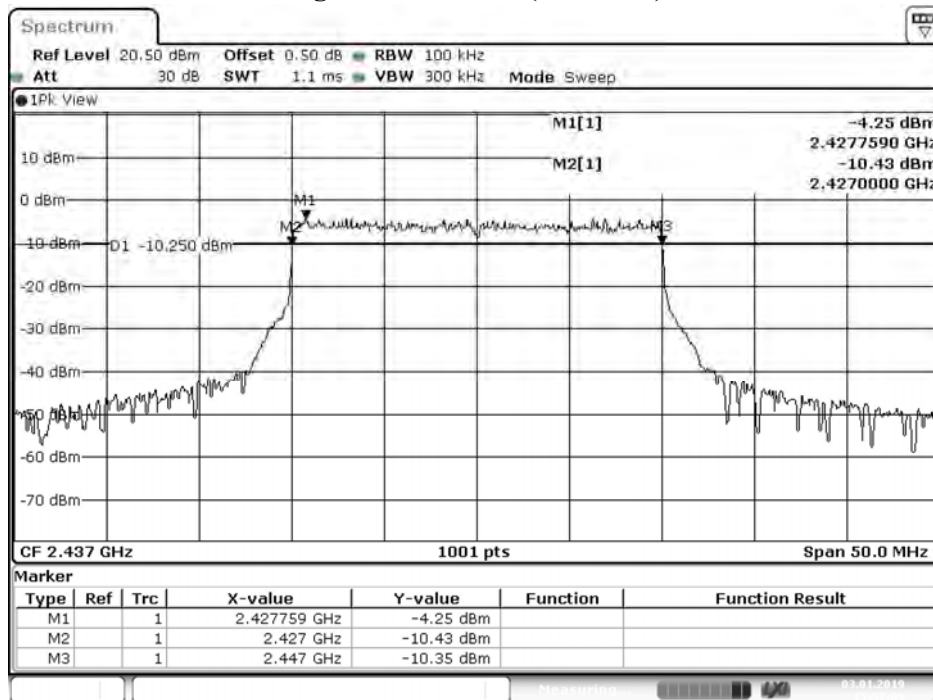

Figure Channel 06 (Chain A2)



Date: 3.JAN.2019 15:57:10

Figure Channel 11 (Chain A1)

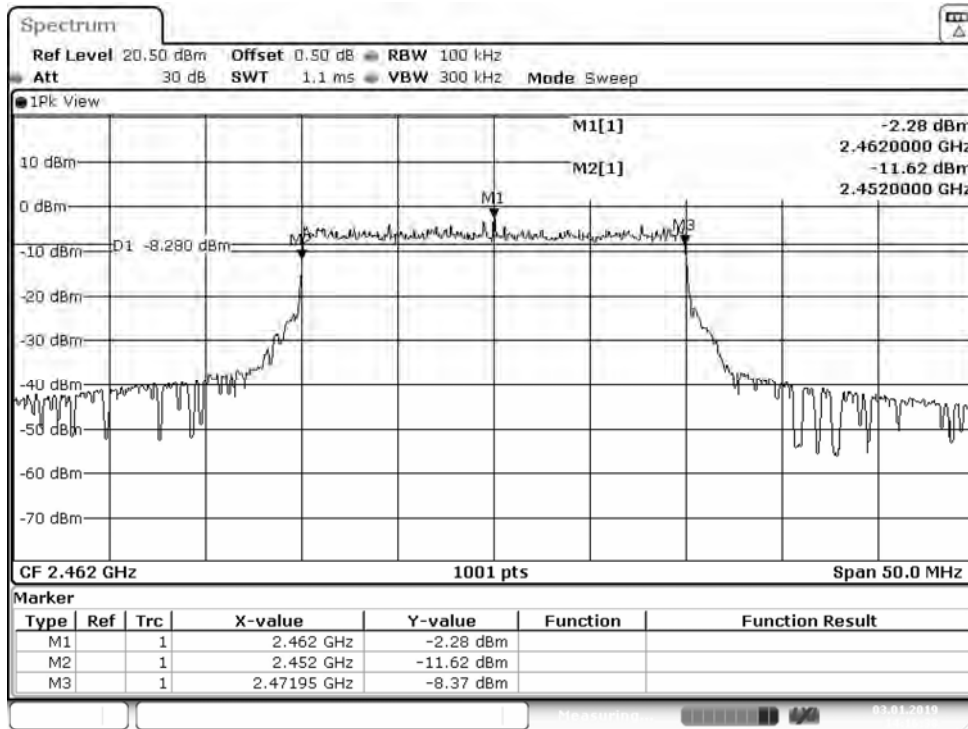
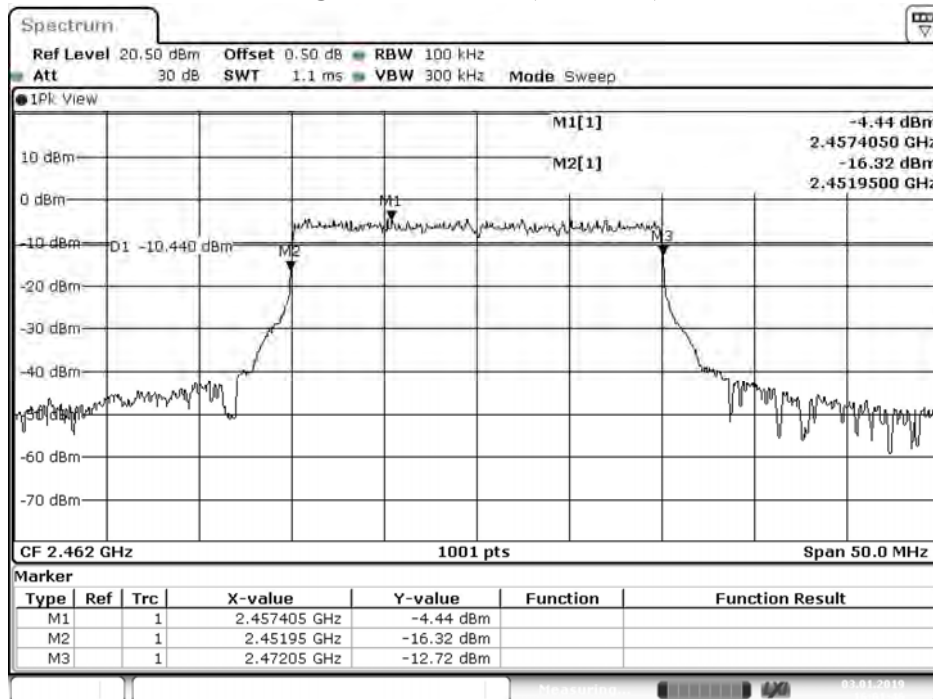

Figure Channel 11 (Chain A2)



Date: 3.JAN.2019 16:01:46

Product : Software defined radio
Test Item : 6dB Bandwidth Data
Test Mode : Mode 2: Transmit_Patch (A1+ A2+ B1+ B2)

Channel No.	Frequency (MHz)	Chain	Measure Level (kHz)	Limit (kHz)	Result
01	2412	A1	20000	>500	Pass
06	2437	A1	20000	>500	Pass
11	2462	A1	20000	>500	Pass
01	2412	A2	20100	>500	Pass
06	2437	A2	20000	>500	Pass
11	2462	A2	20100	>500	Pass
01	2412	B1	19900	>500	Pass
06	2437	B1	20000	>500	Pass
11	2462	B1	20000	>500	Pass
01	2412	B2	20050	>500	Pass
06	2437	B2	20050	>500	Pass
11	2462	B2	20100	>500	Pass

Figure Channel 01 (Chain A1)

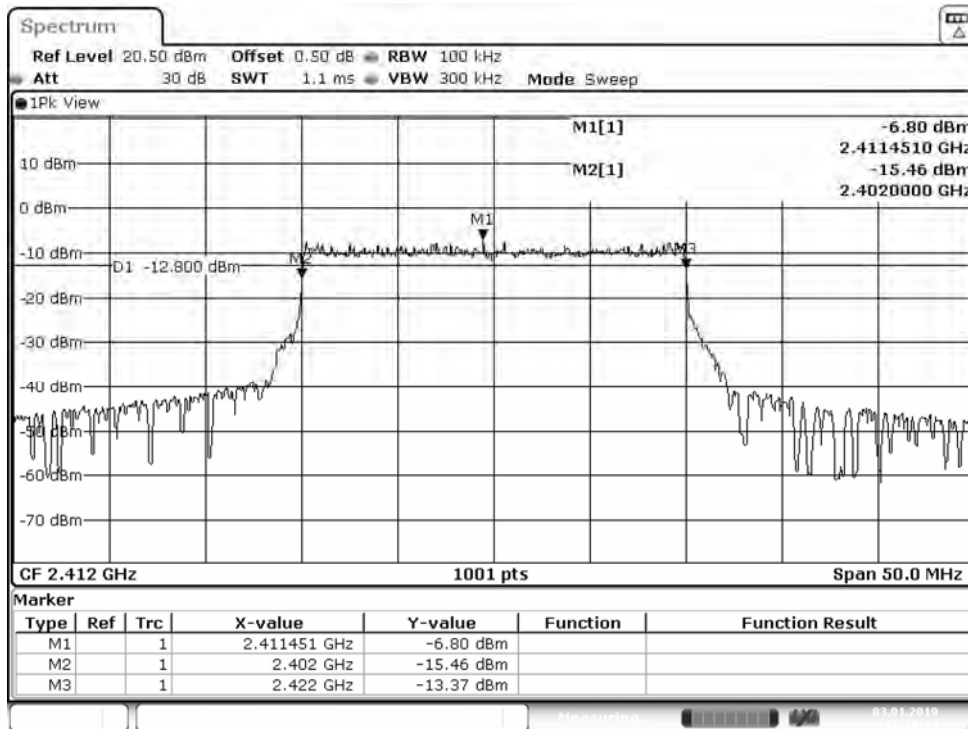
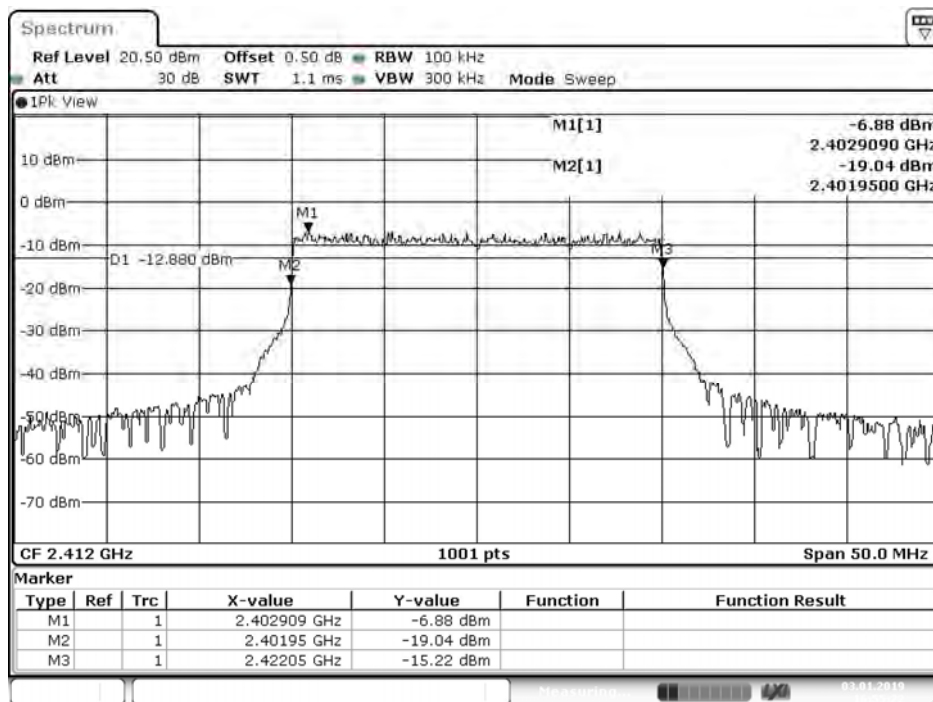

Figure Channel 01 (Chain A2)



Date: 3.JAN.2019 16:55:22

Figure Channel 01 (Chain B1)

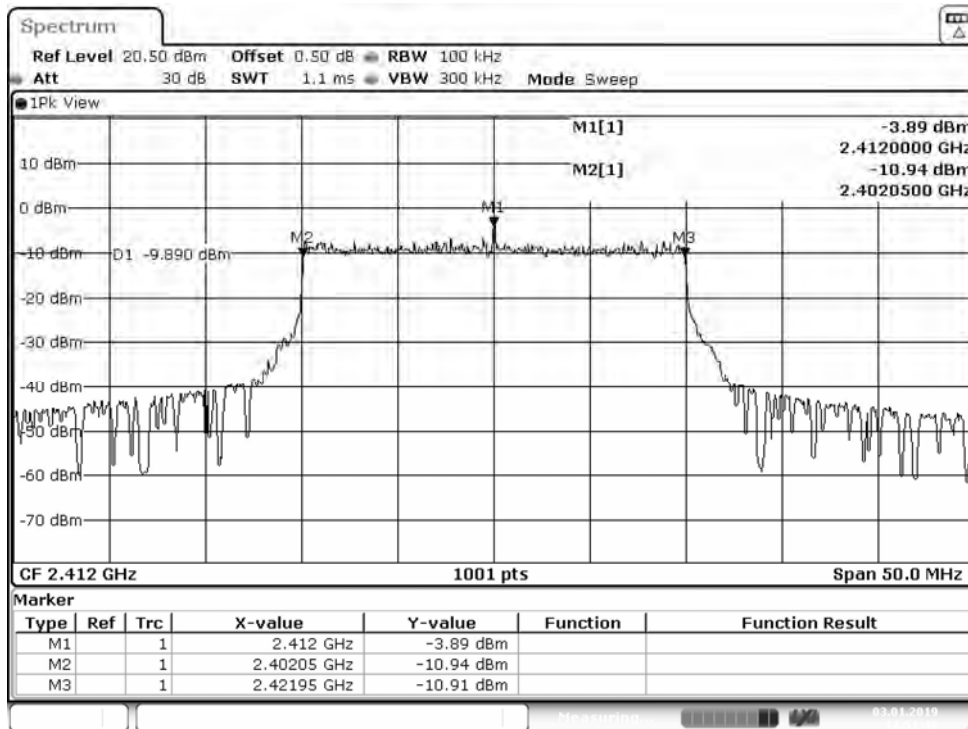
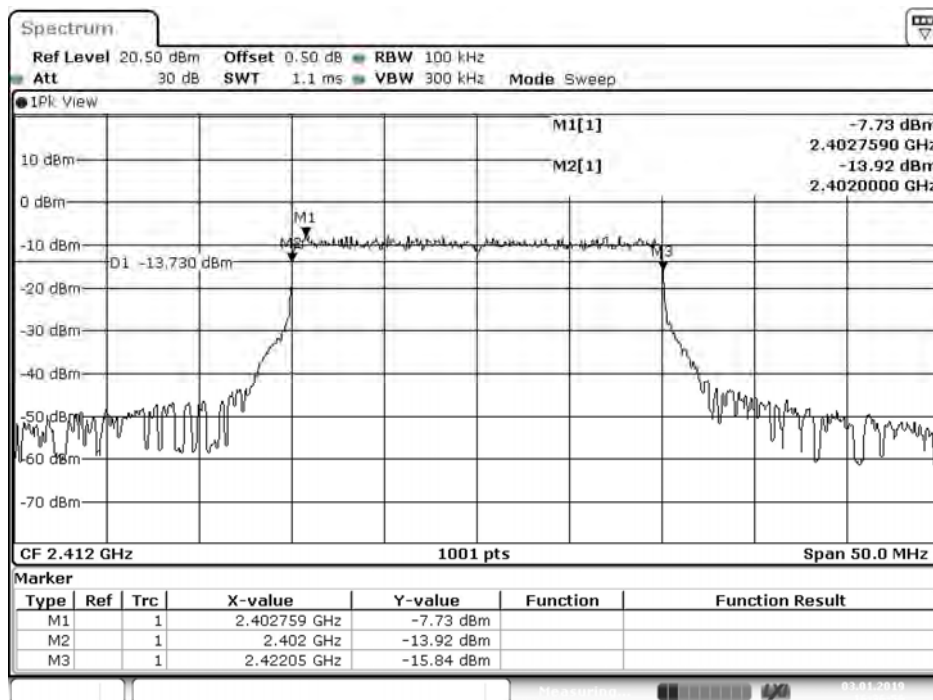

Figure Channel 01 (Chain B2)



Date: 3.JAN.2019 16:36:56

Figure Channel 06 (Chain A1)

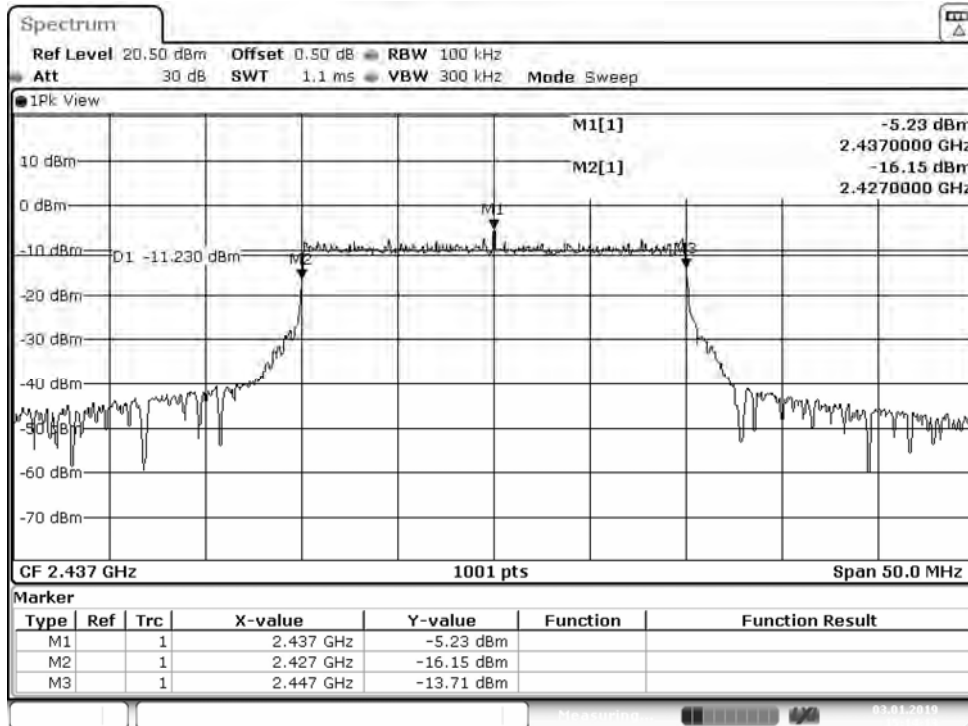
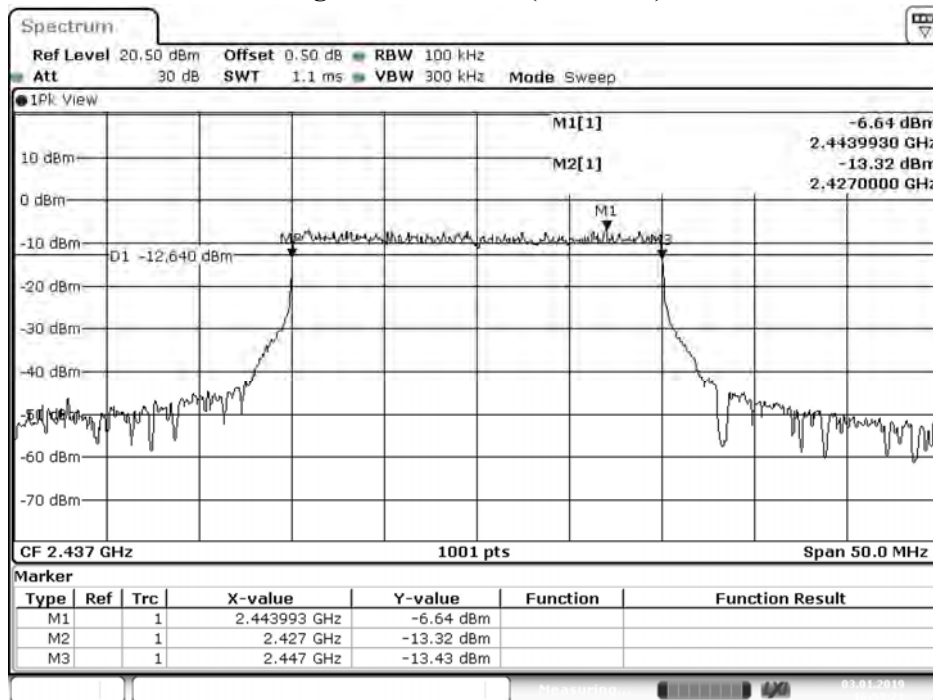

Figure Channel 06 (Chain A2)



Date: 3.JAN.2019 16:59:22

Figure Channel 06 (Chain B1)

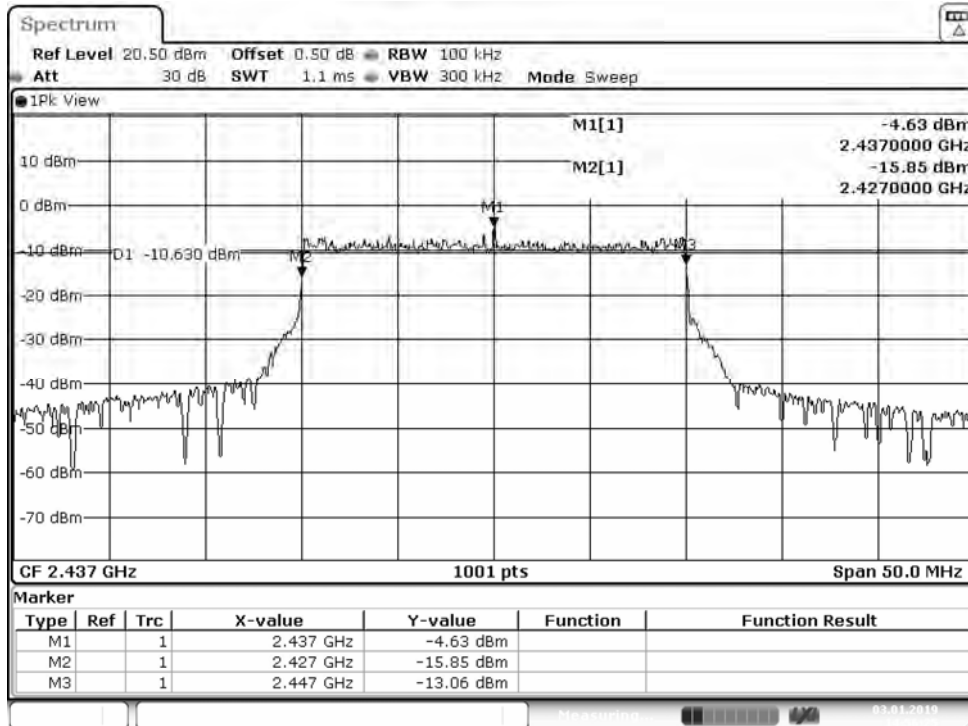
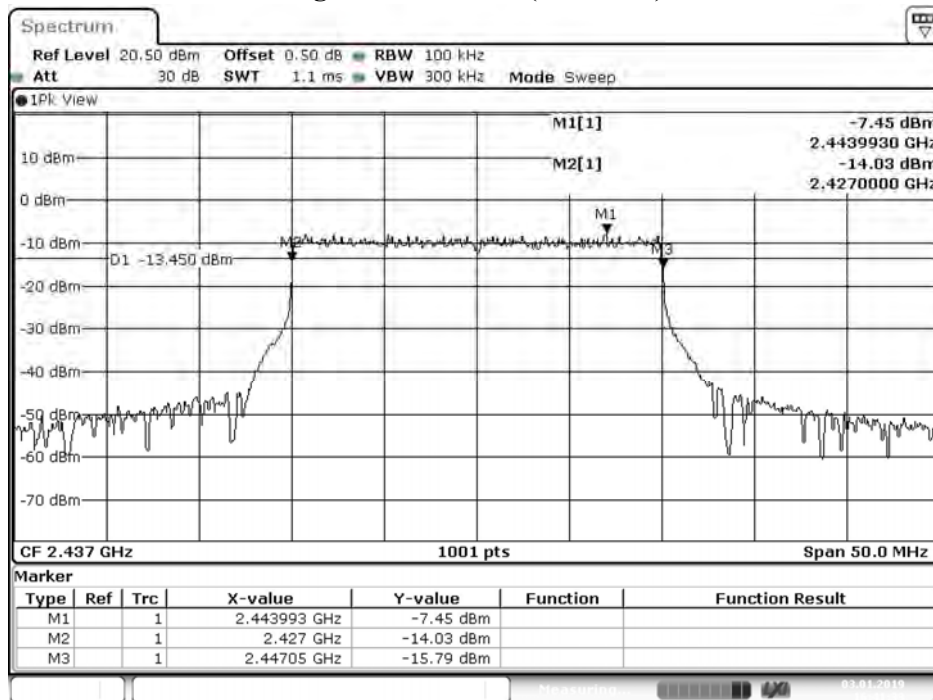

Figure Channel 06 (Chain B2)



Date: 3.JAN.2019 16:41:33

Figure Channel 11 (Chain A1)

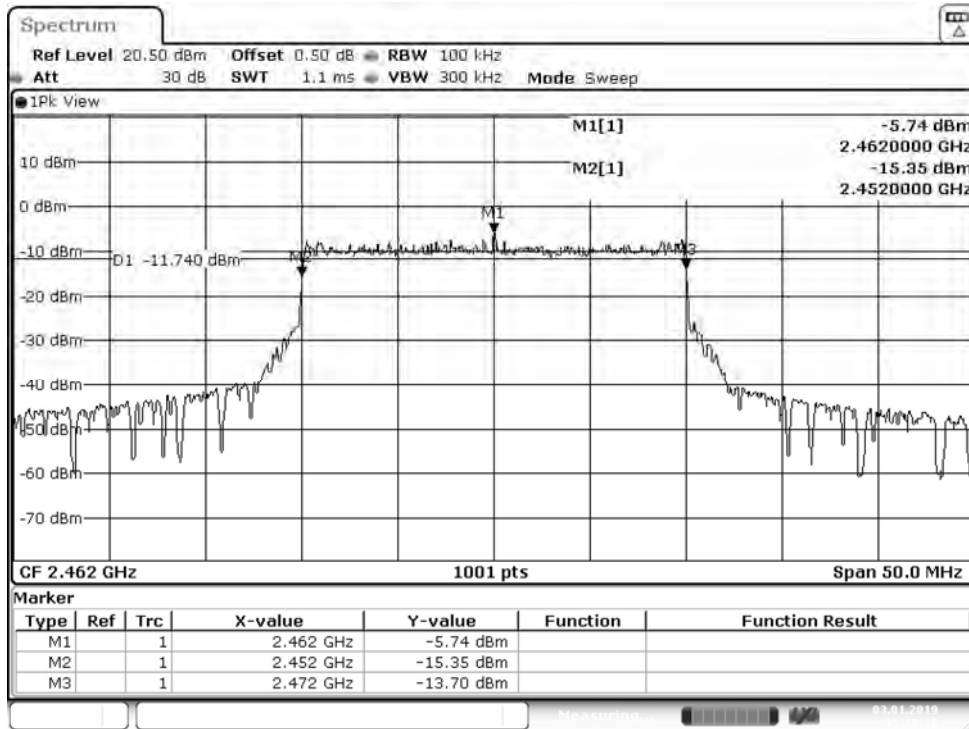
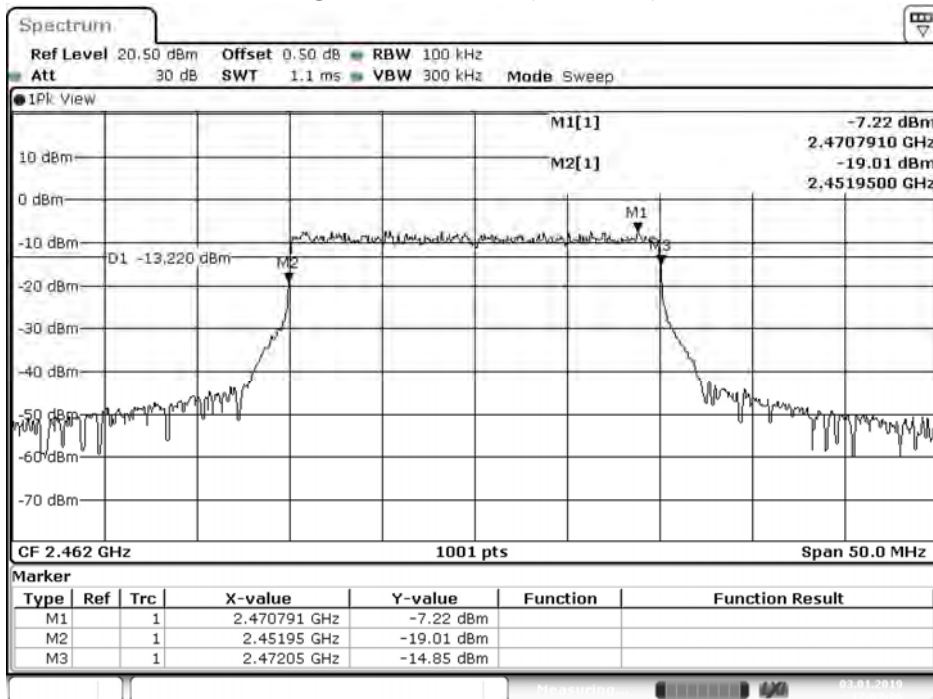

Figure Channel 11 (Chain A2)



Date: 3.JAN.2019 17:03:26

Figure Channel 11 (Chain B1)

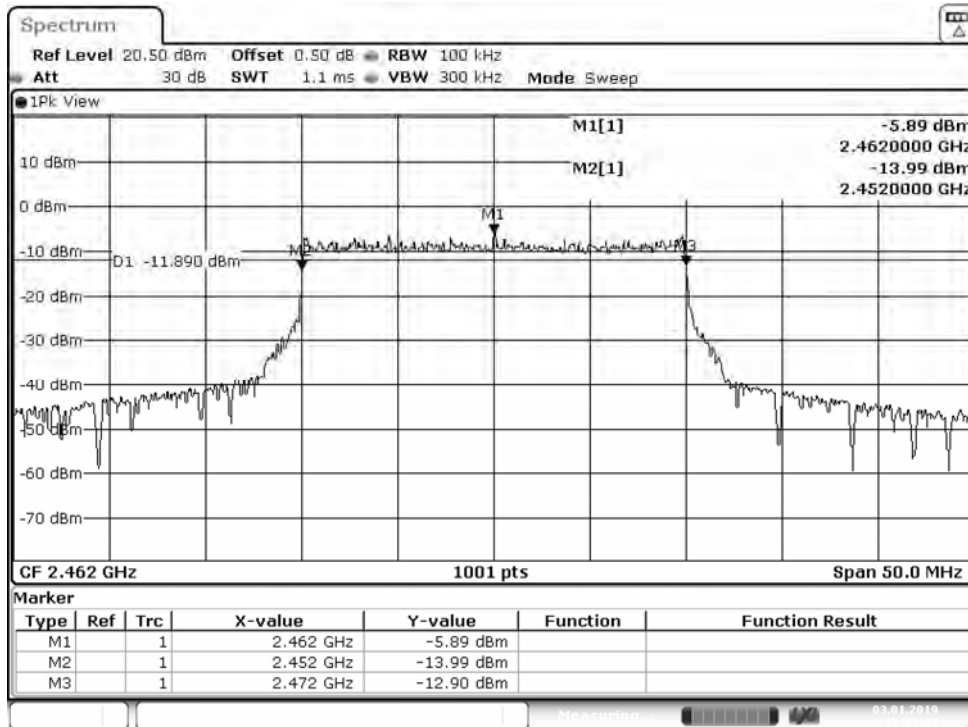
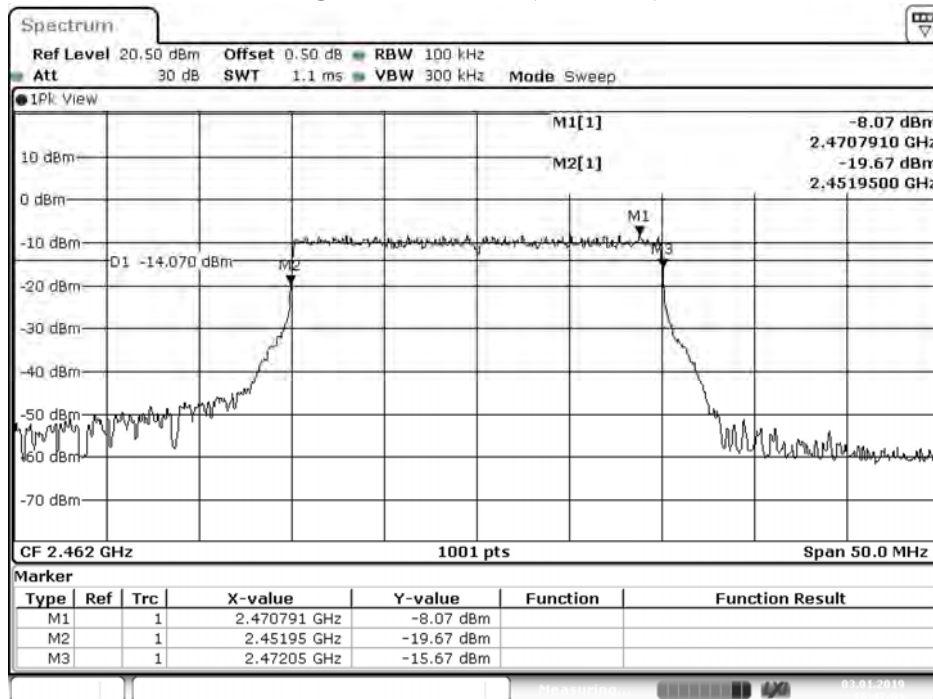

Figure Channel 11 (Chain B2)



Date: 3.JAN.2019 16:47:04

Product : Software defined radio
Test Item : 6dB Bandwidth Data
Test Mode : Mode 2: Transmit_Patch (B1+ B2)

Channel No.	Frequency (MHz)	Chain	Measure Level (kHz)	Limit (kHz)	Result
01	2412	B1	19900	>500	Pass
06	2437	B1	19950	>500	Pass
11	2462	B1	19900	>500	Pass
01	2412	B2	20100	>500	Pass
06	2437	B2	20050	>500	Pass
11	2462	B2	20050	>500	Pass

Figure Channel 01 (Chain B1)

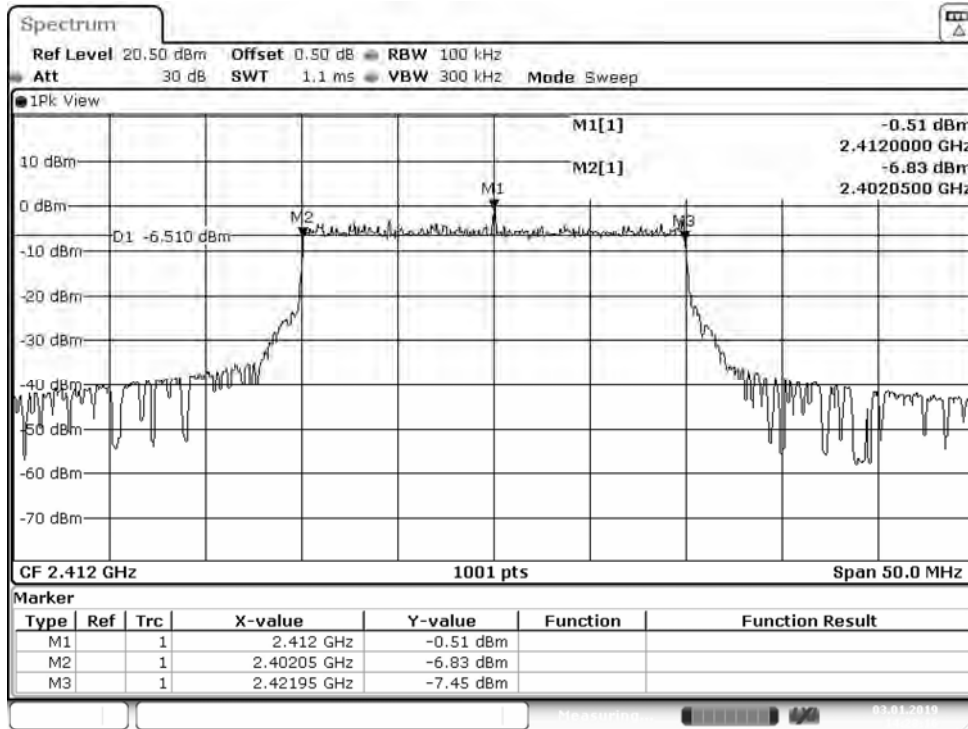
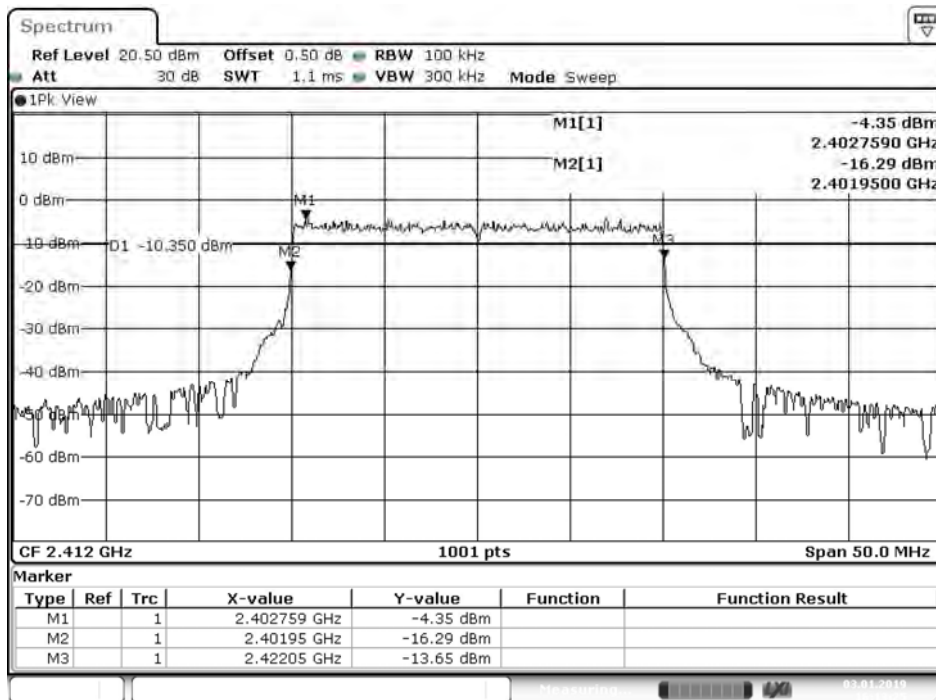

Figure Channel 01 (Chain B2)



Date: 3.JAN.2019 16:13:25

Figure Channel 06 (Chain B1)

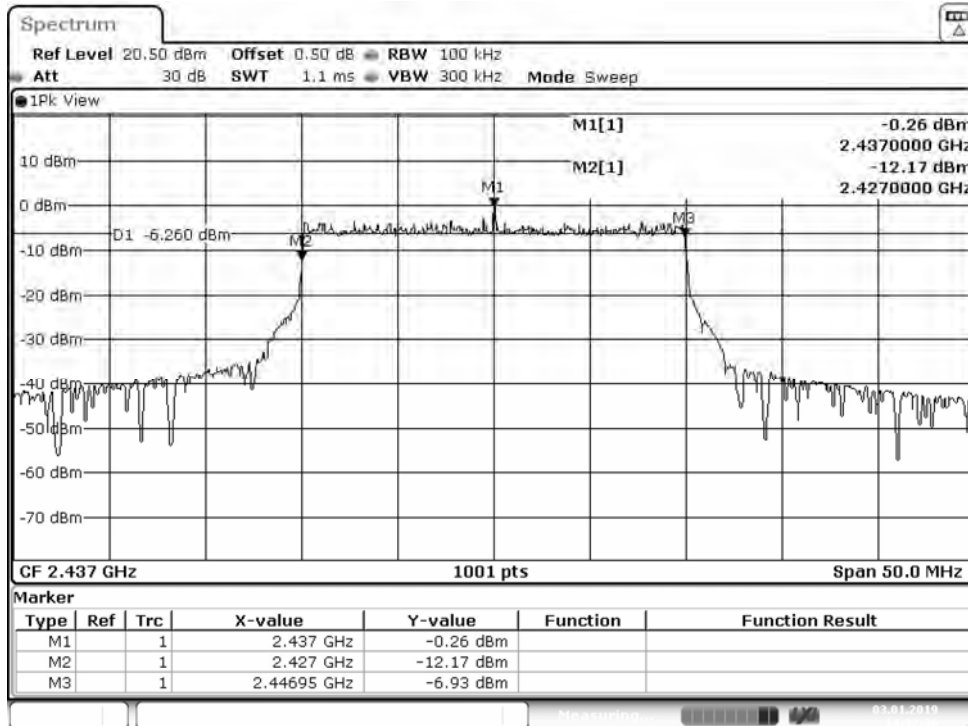
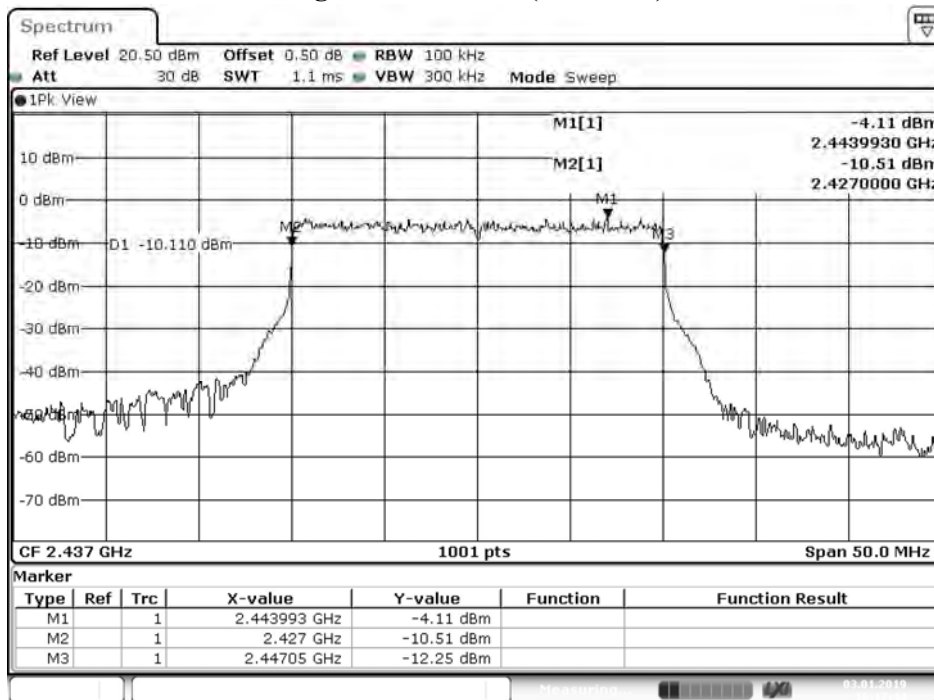

Figure Channel 06 (Chain B2)



Date: 3.JAN.2019 16:17:44

Figure Channel 11 (Chain B1)

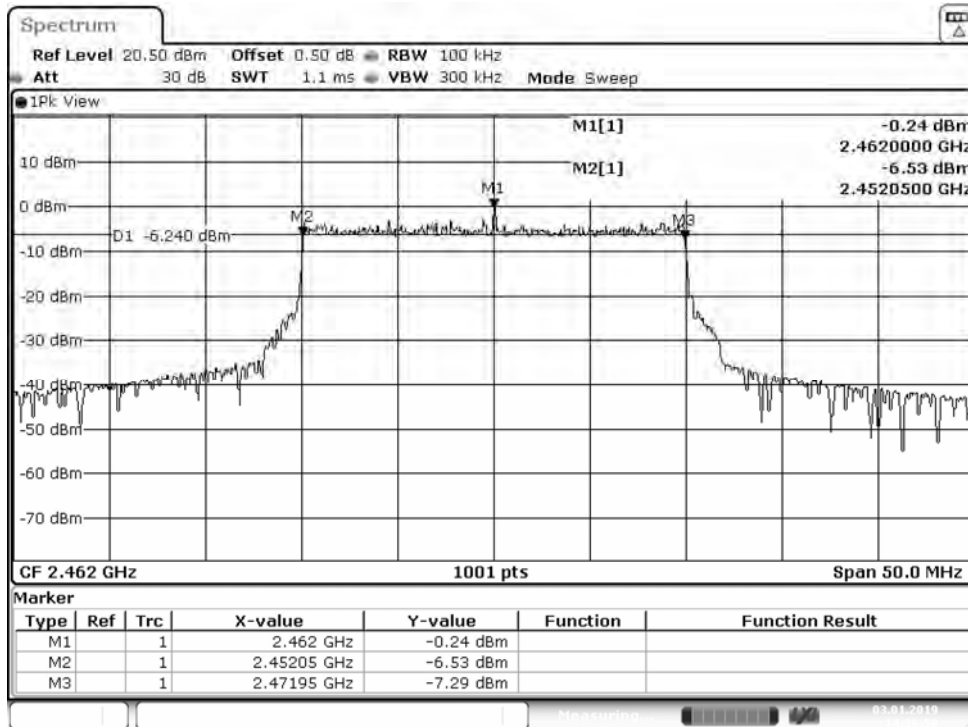
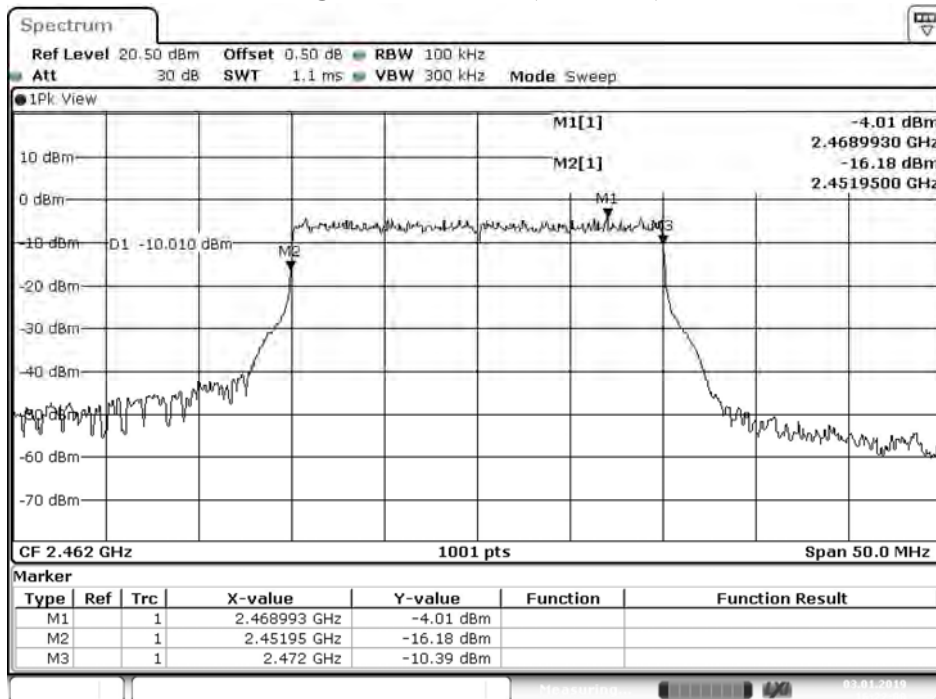

Figure Channel 11 (Chain B2)



Date: 3.JAN.2019 16:21:59

8. Power Density

8.1. Test Setup

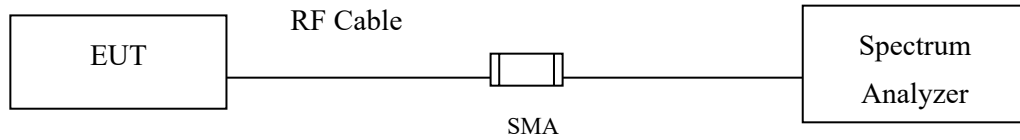

8.2. Limits

The transmitted power density averaged over any 1 second interval shall not be greater +8dBm in any 3kHz bandwidth.

8.3. Test Procedure

Tested according to DTS test procedure of KDB558074 section 8.4 for compliance to FCC 47CFR 15.247 requirements.

8.4. Uncertainty

$\pm 1.23\text{dB}$

8.5. Test Result of Power Density

Product : Software defined radio
 Test Item : Power Density Data
 Test Mode : Mode 1: Transmit_Dipole (A1+ A2)

Channel No.	Frequency (MHz)	Chain (dBm)	PPSD/MHz (dBm)	10*log(2) (dB)	Measure Level (dBm)	Limit (dBm)	Result
01	2412	A1	2.930	3.010	5.940	≤ 8dBm	Pass
		A2	3.580	3.010	6.590	≤ 8dBm	Pass
06	2437	A1	2.500	3.010	5.510	≤ 8dBm	Pass
		A2	3.160	3.010	6.170	≤ 8dBm	Pass
11	2462	A1	4.490	3.010	7.500	≤ 8dBm	Pass
		A2	2.760	3.010	5.770	≤ 8dBm	Pass

Note:

The quantity $10 \cdot \log 2$ (two antennas) is added to the spectrum peak value according to document 662911 D01.

Figure Channel 01 (Chain A1)

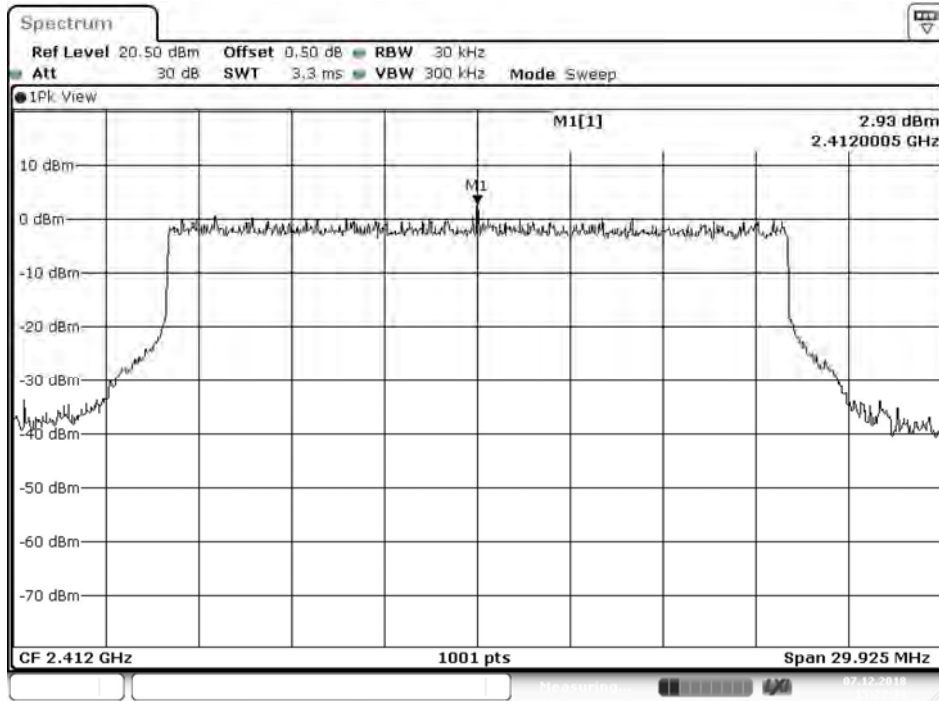

Date: 7.DEC.2018 15:22:33

Figure Channel 01 (Chain A2)

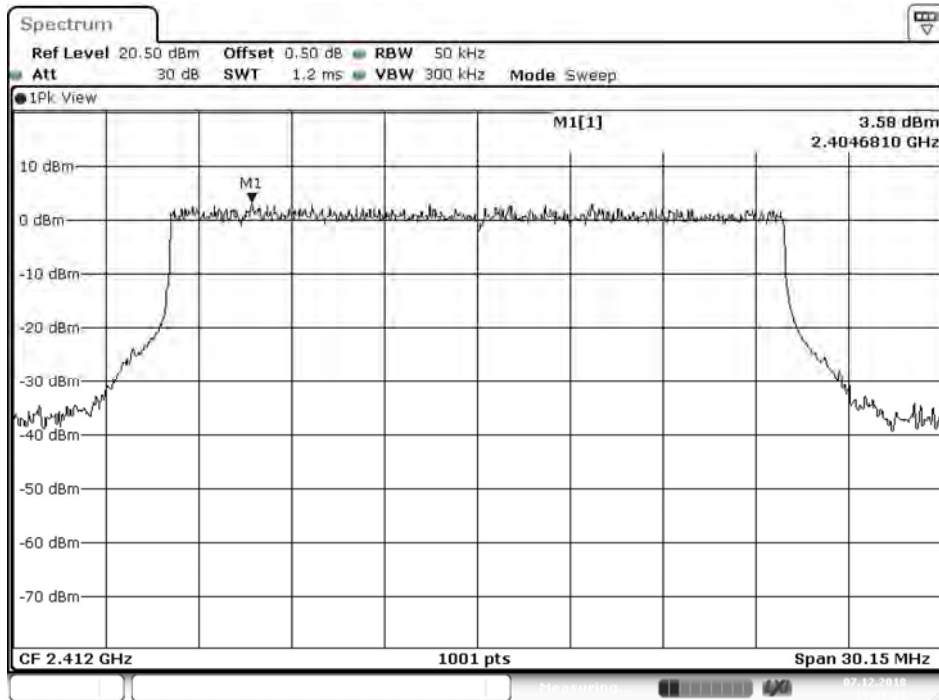

Date: 7.DEC.2018 15:21:28

Figure Channel 06 (Chain A1)

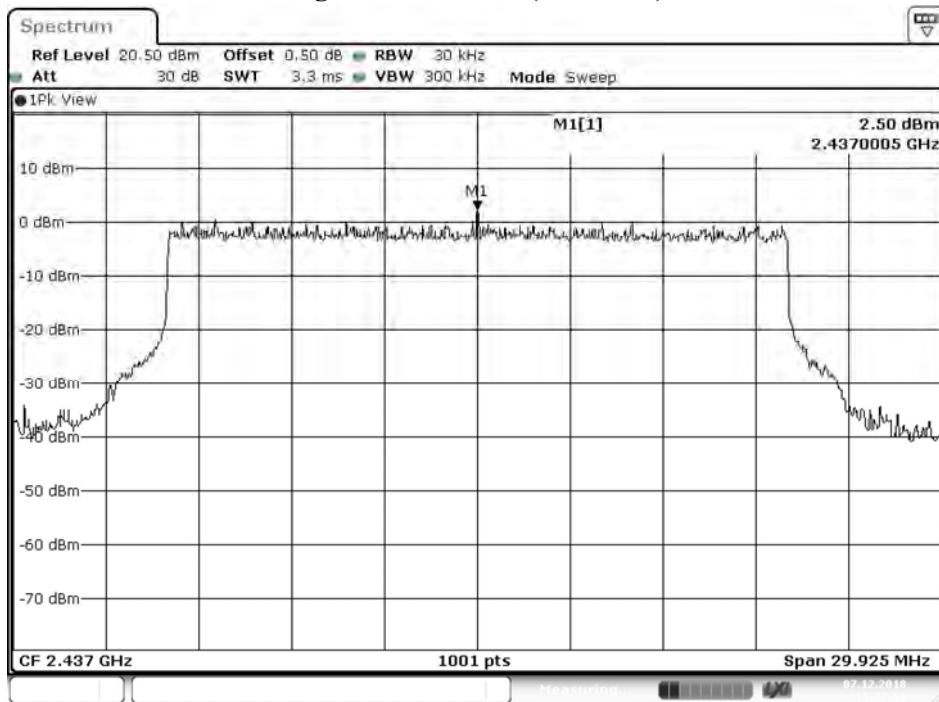

Date: 7.DEC.2018 15:27:57

Figure Channel 06 (Chain A2)

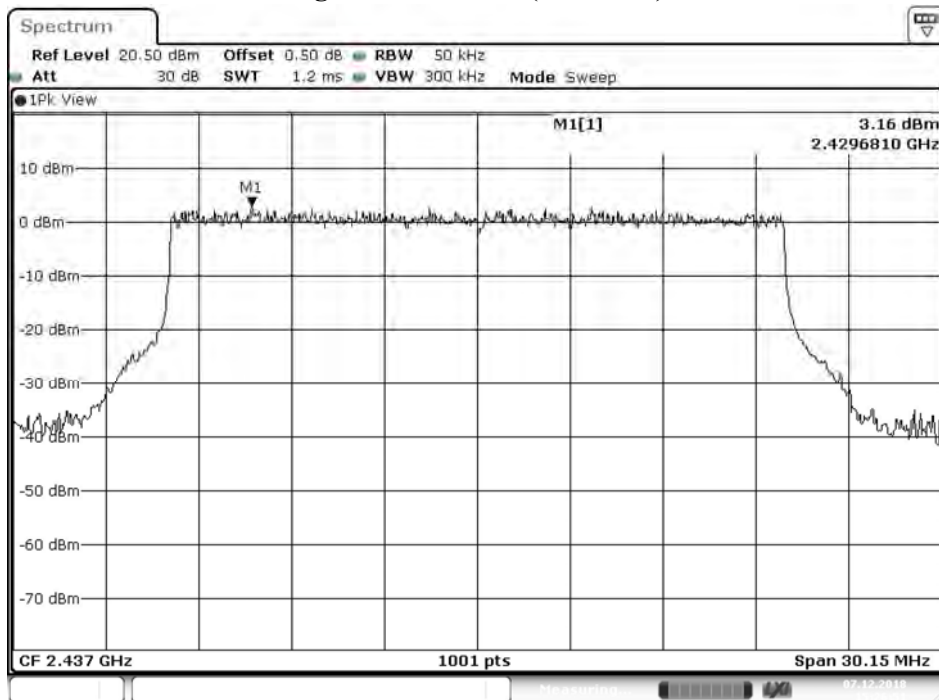

Date: 7.DEC.2018 15:26:52

Figure Channel 11 (Chain A1)

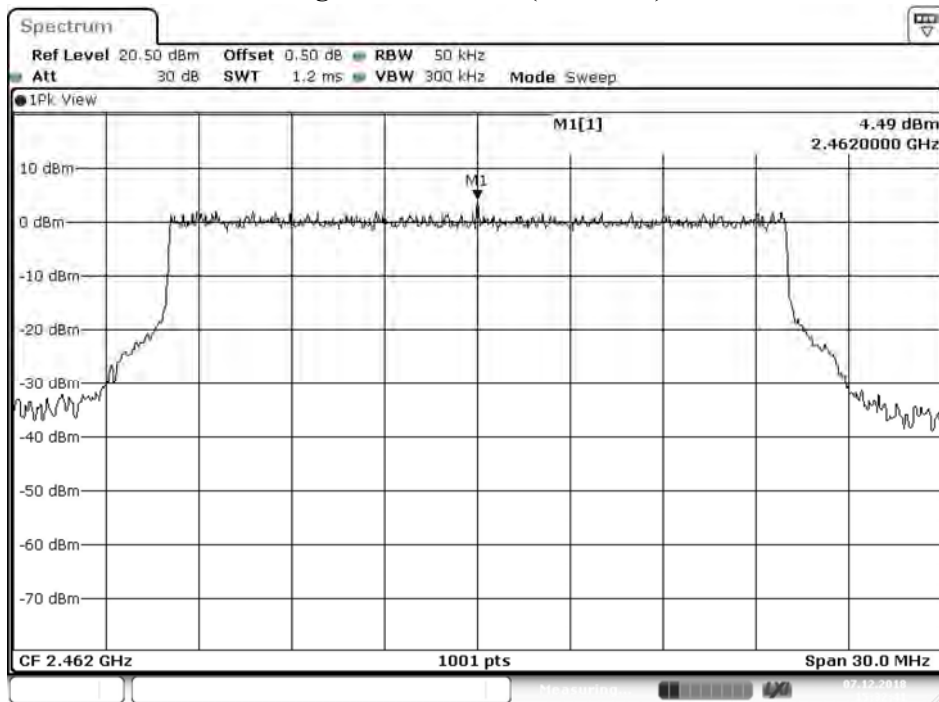

Date: 7.DEC.2018 15:32:41

Figure Channel 11 (Chain A2)

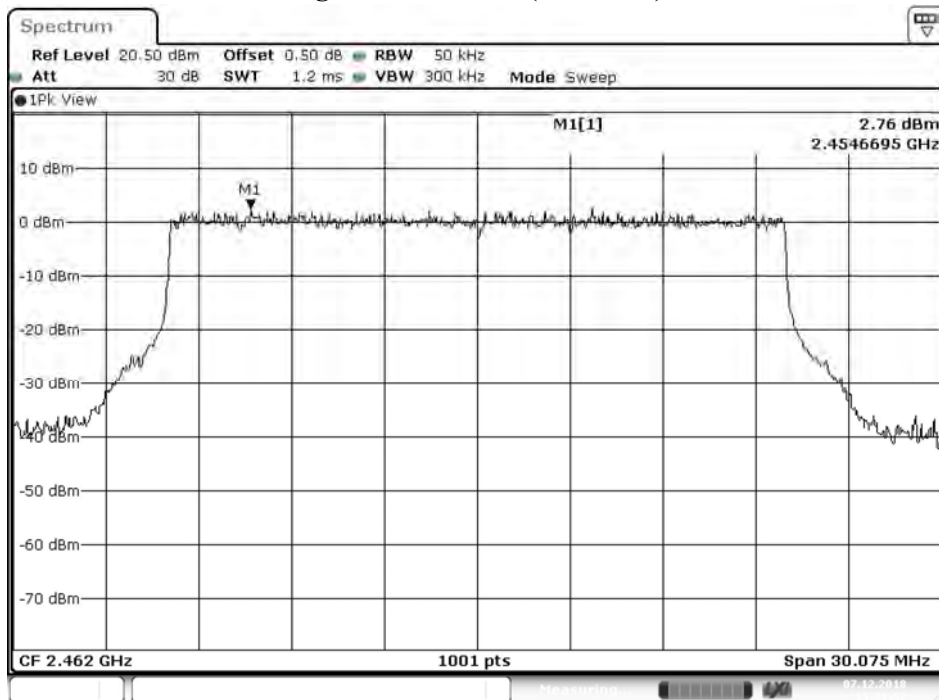

Date: 7.DEC.2018 15:31:52

Product : Software defined radio
 Test Item : Power Density Data
 Test Mode : Mode 1: Transmit_Dipole (A1+ A2+ B1+ B2)

Channel No.	Frequency (MHz)	Chain (dBm)	PPSD/MHz (dBm)	10*log(4) (dB)	Measure Level (dBm)	Limit (dBm)	Result
01	2412	A1	0.190	6.021	6.211	≤ 8dBm	Pass
		A2	0.820	6.021	6.841	≤ 8dBm	Pass
		B1	-0.730	6.021	5.291	≤ 8dBm	Pass
		B2	-0.210	6.021	5.811	≤ 8dBm	Pass
06	2437	A1	-1.540	6.021	4.481	≤ 8dBm	Pass
		A2	1.740	6.021	7.761	≤ 8dBm	Pass
		B1	0.860	6.021	6.881	≤ 8dBm	Pass
		B2	0.910	6.021	6.931	≤ 8dBm	Pass
11	2462	A1	1.080	6.021	7.101	≤ 8dBm	Pass
		A2	1.510	6.021	7.531	≤ 8dBm	Pass
		B1	1.040	6.021	7.061	≤ 8dBm	Pass
		B2	0.770	6.021	6.791	≤ 8dBm	Pass

Note:

The quantity 10*log 4 (four antennas) is added to the spectrum peak value according to document 662911 D01.

Figure Channel 01 (Chain A1)

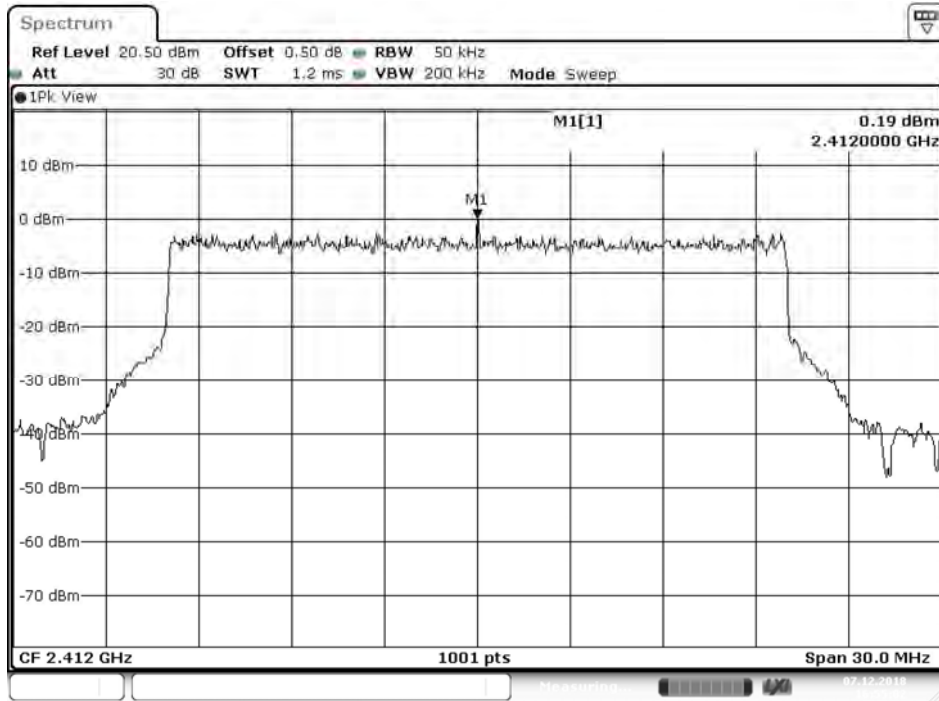

Date: 7.DEC.2018 16:55:03

Figure Channel 01 (Chain A2)

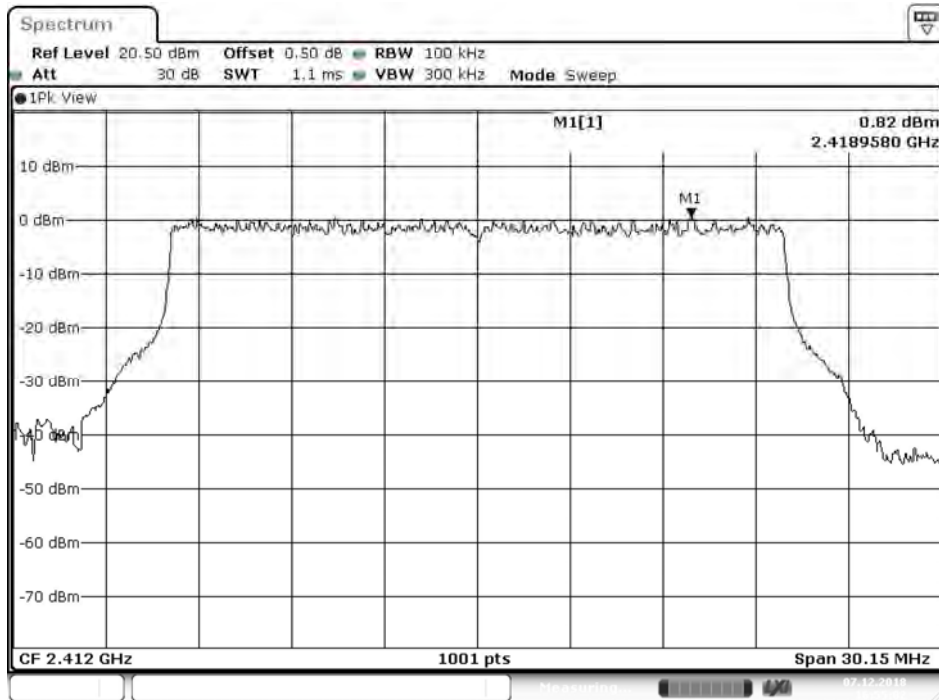

Date: 7.DEC.2018 16:55:03

Figure Channel 01 (Chain B1)

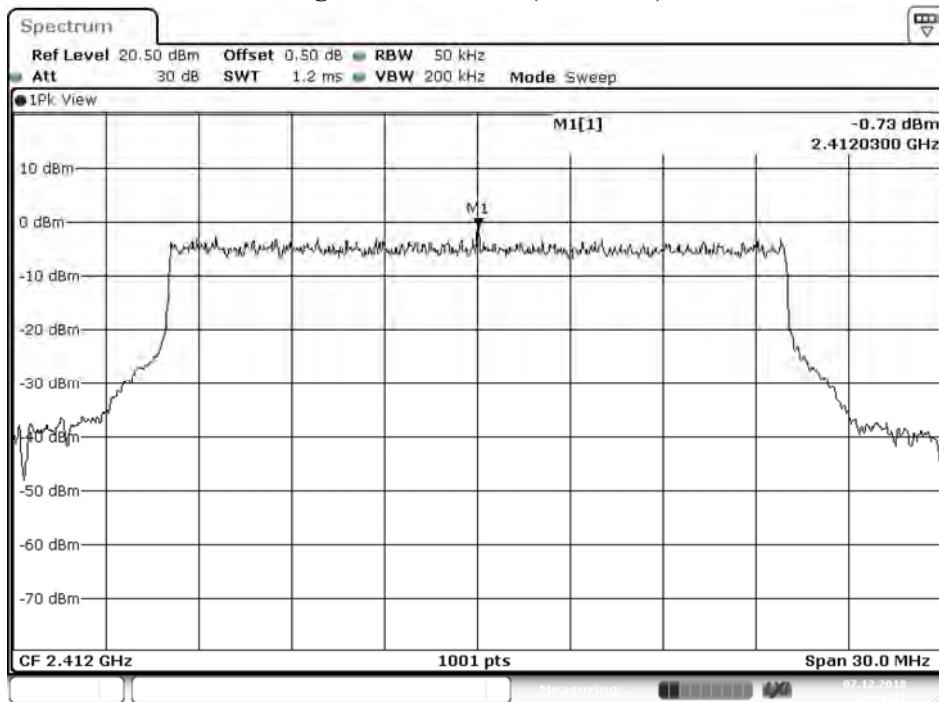

Date: 7.DEC.2018 16:36:01

Figure Channel 01 (Chain B2)

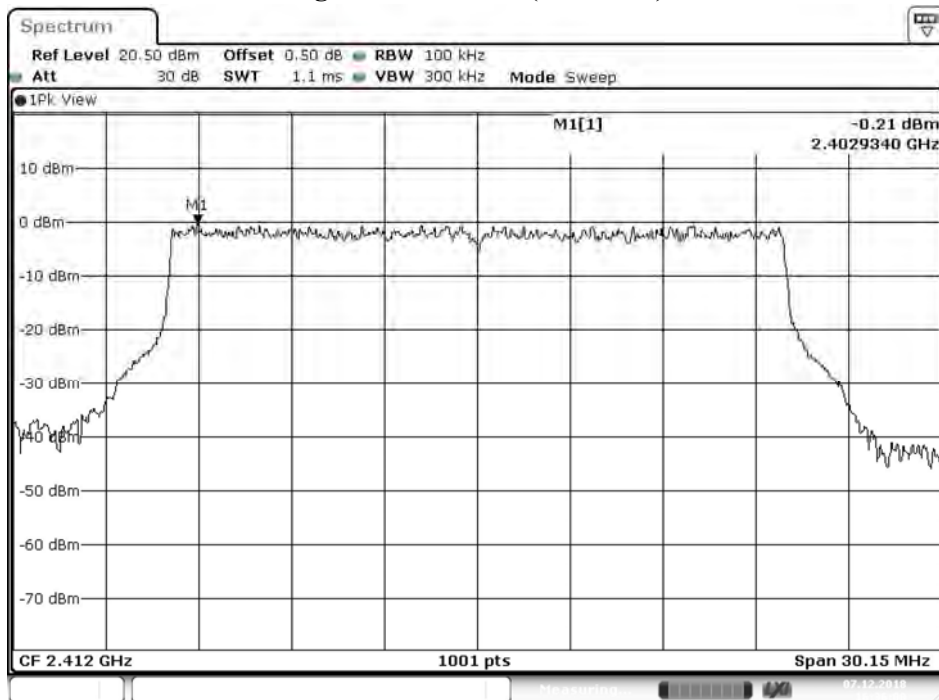

Date: 7.DEC.2018 16:36:01

Figure Channel 06 (Chain A1)

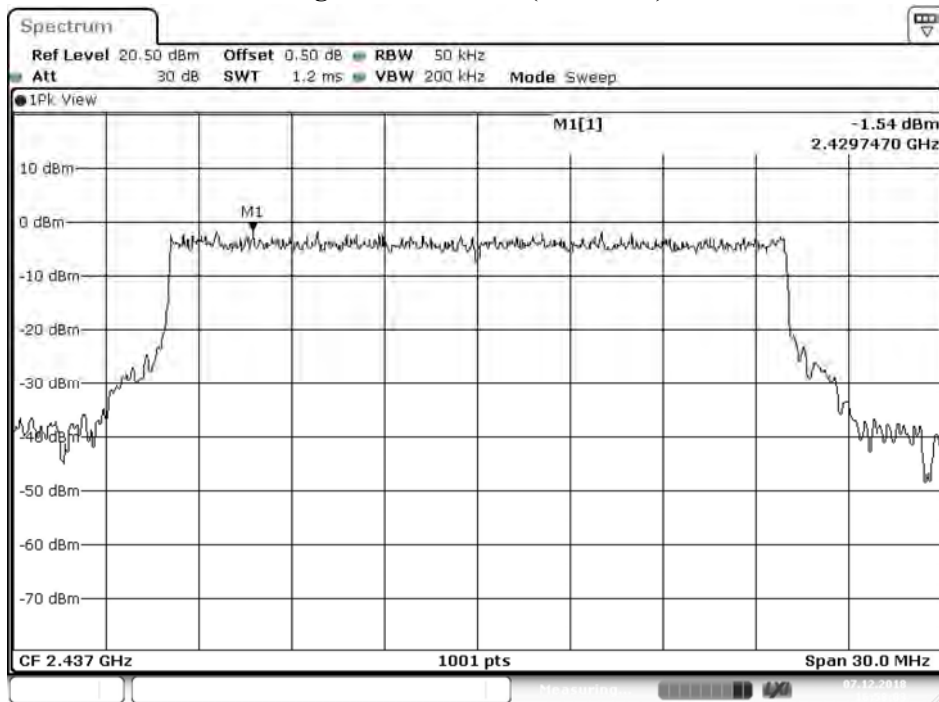

Date: 7.DEC.2018 16:58:03

Figure Channel 06 (Chain A2)

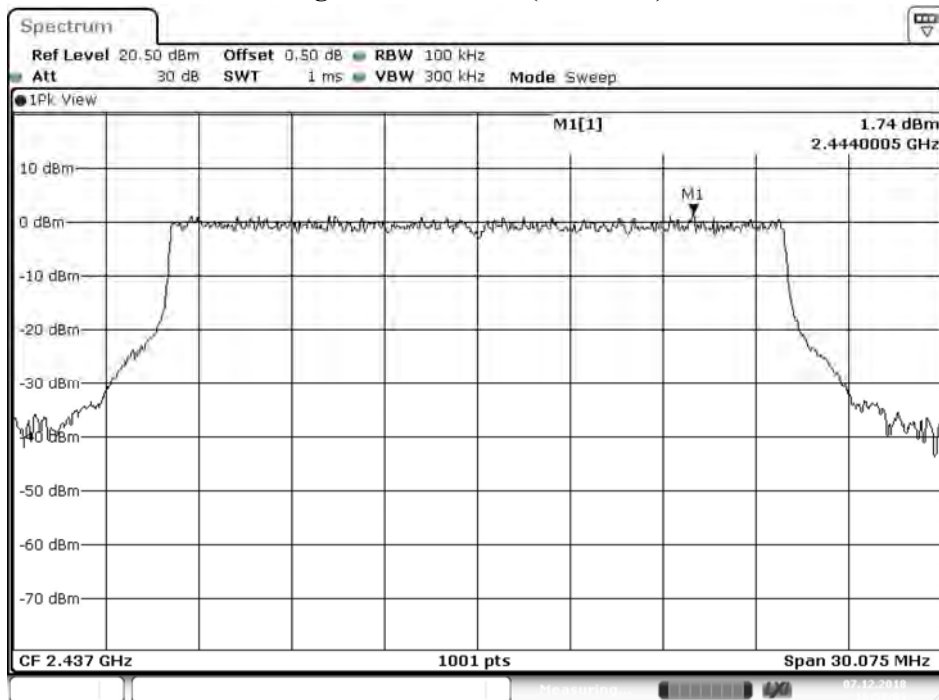

Date: 7.DEC.2018 16:58:03

Figure Channel 06 (Chain B1)

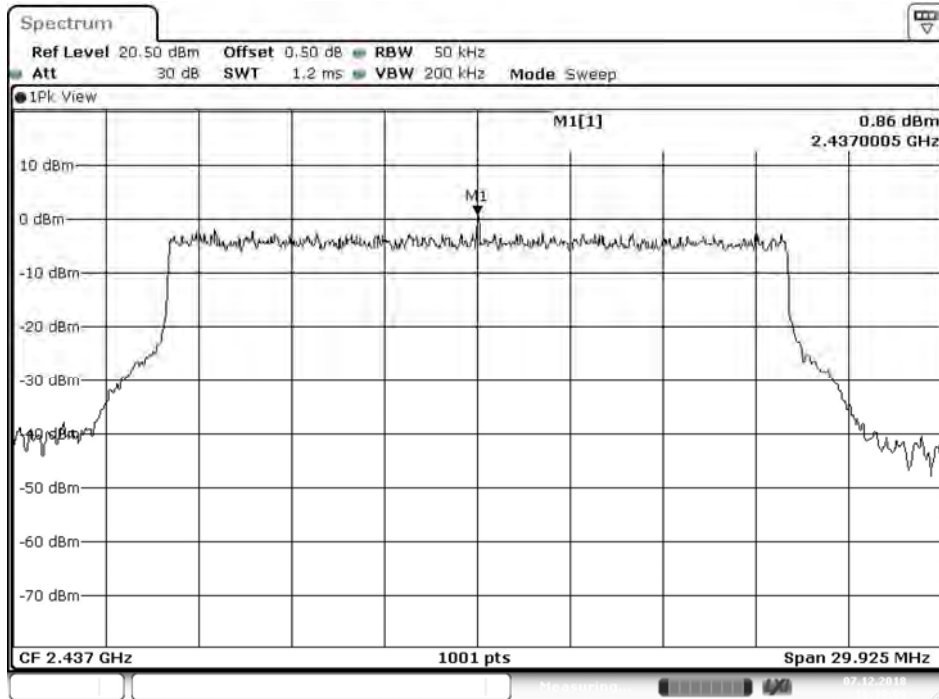

Date: 7.DEC.2018 16:39:09

Figure Channel 06 (Chain B2)

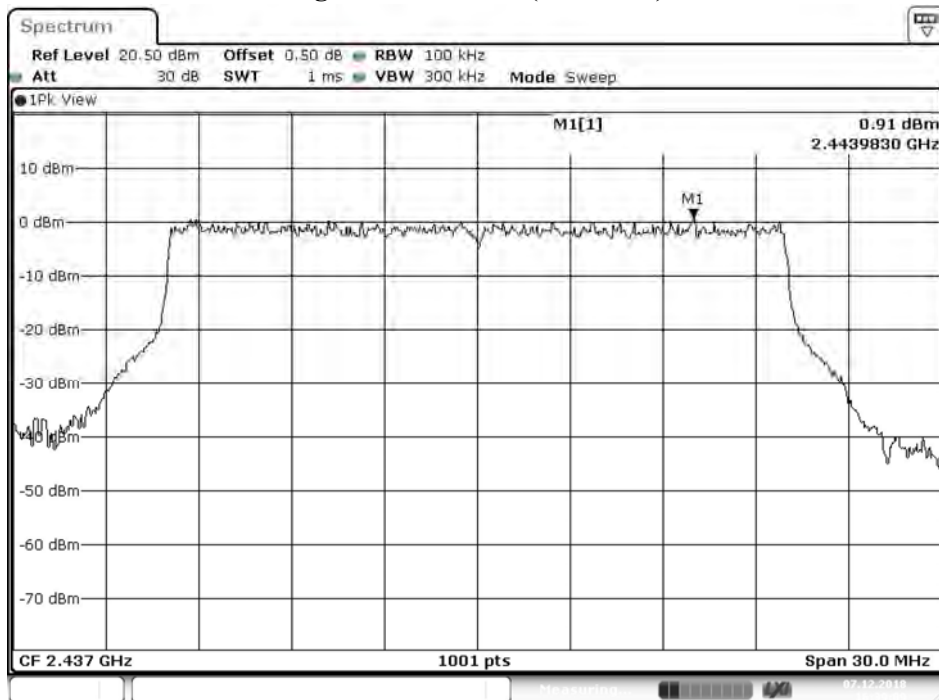

Date: 7.DEC.2018 16:39:09

Figure Channel 11 (Chain A1)

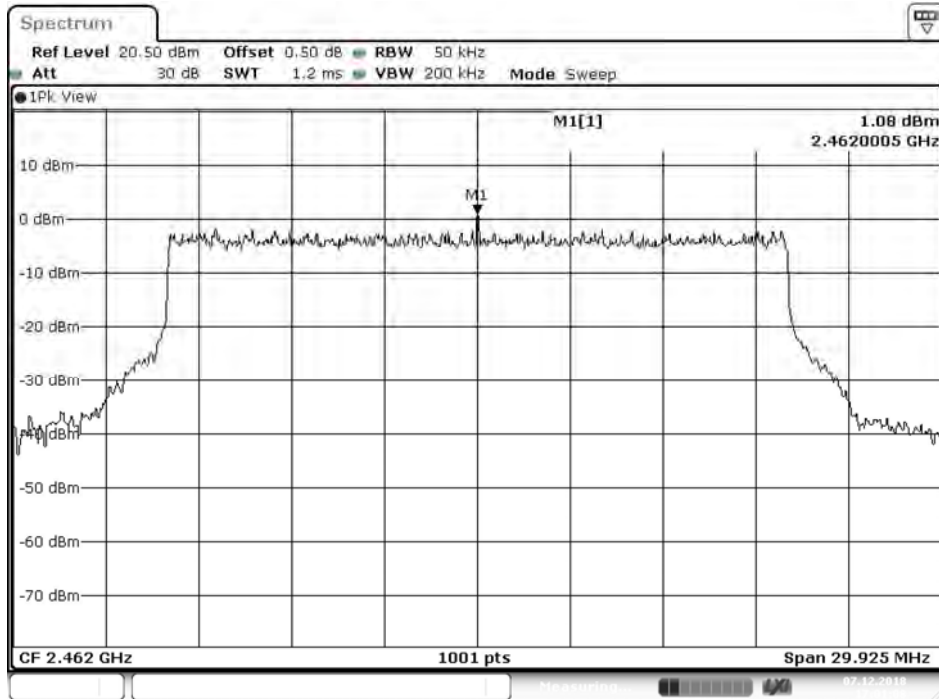

Date: 7.DEC.2018 17:01:09

Figure Channel 11 (Chain A2)

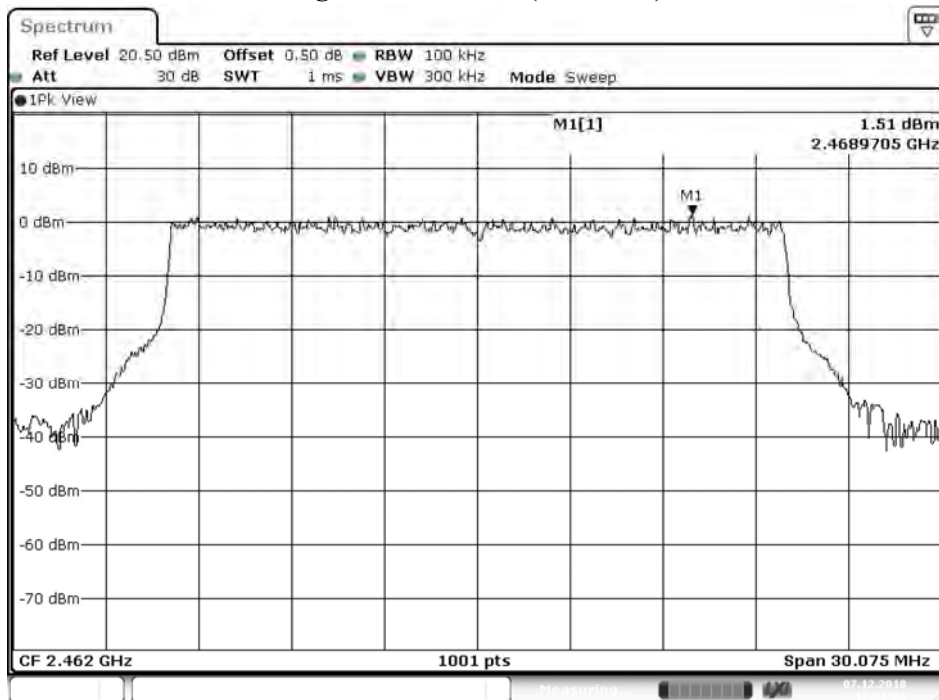

Date: 7.DEC.2018 17:01:09

Figure Channel 11 (Chain B1)

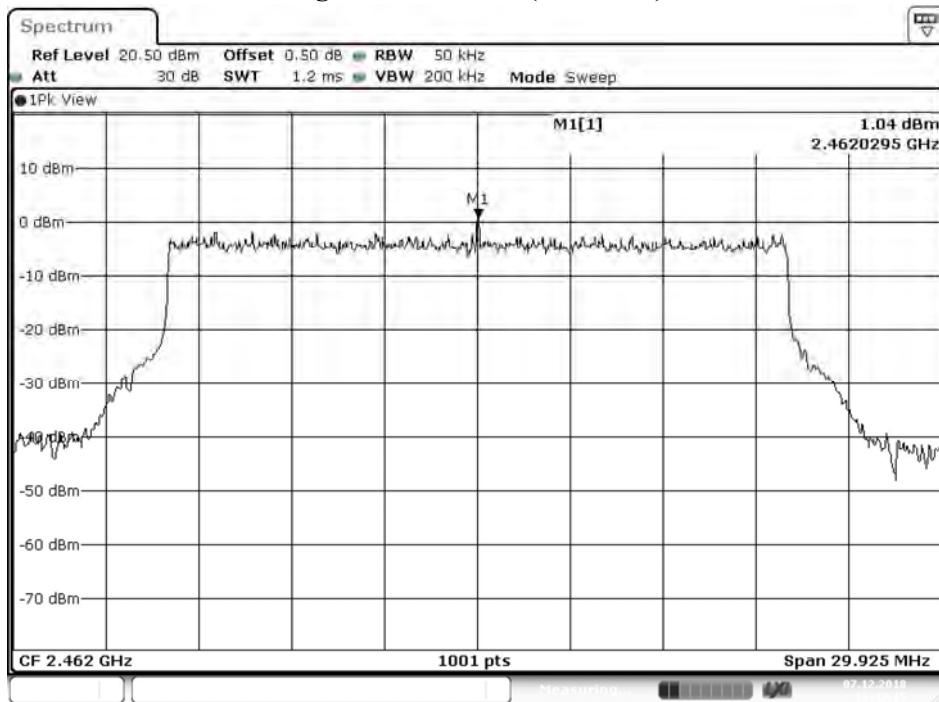

Date: 7.DEC.2018 16:42:15

Figure Channel 11 (Chain B2)

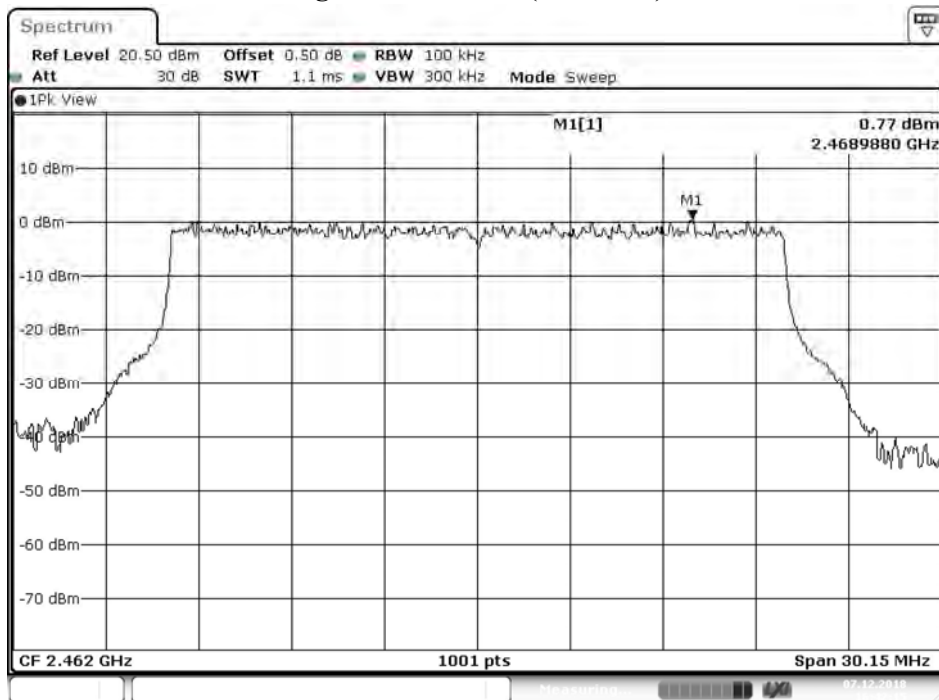

Date: 7.DEC.2018 16:42:15

Product : Software defined radio
 Test Item : Power Density Data
 Test Mode : Mode 1: Transmit_Dipole (B1+ B2)

Channel No.	Frequency (MHz)	Chain (dBm)	PPSD/MHz (dBm)	10*log(2) (dB)	Measure Level (dBm)	Limit (dBm)	Result
01	2412	B1	4.800	3.010	7.810	≤ 8dBm	Pass
		B2	4.360	3.010	7.370	≤ 8dBm	Pass
06	2437	B1	3.250	3.010	6.260	≤ 8dBm	Pass
		B2	4.680	3.010	7.690	≤ 8dBm	Pass
11	2462	B1	4.670	3.010	7.680	≤ 8dBm	Pass
		B2	4.470	3.010	7.480	≤ 8dBm	Pass

Note:

The quantity $10 \cdot \log 2$ (two antennas) is added to the spectrum peak value according to document 662911 D01.

Figure Channel 01 (Chain B1)

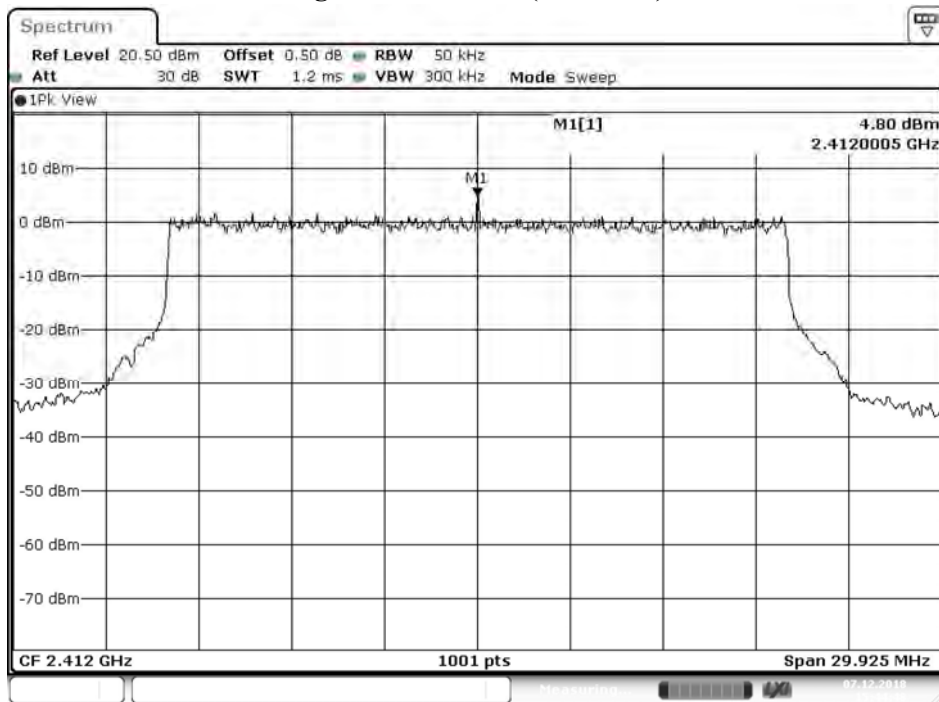

Date: 7.DEC.2018 15:44:49

Figure Channel 01 (Chain B2)

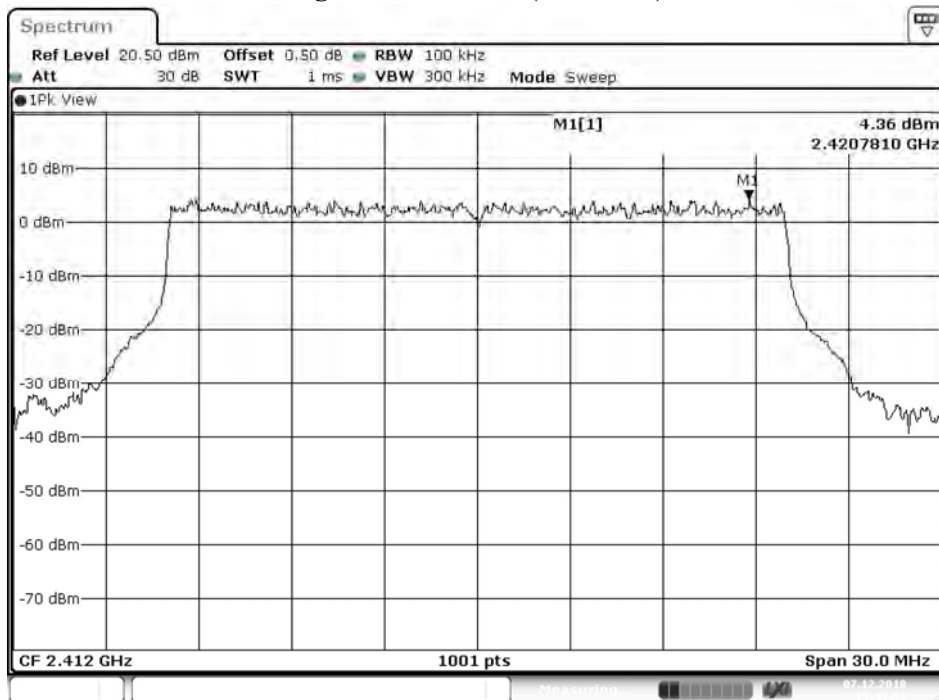

Date: 7.DEC.2018 15:44:00

Figure Channel 06 (Chain B1)

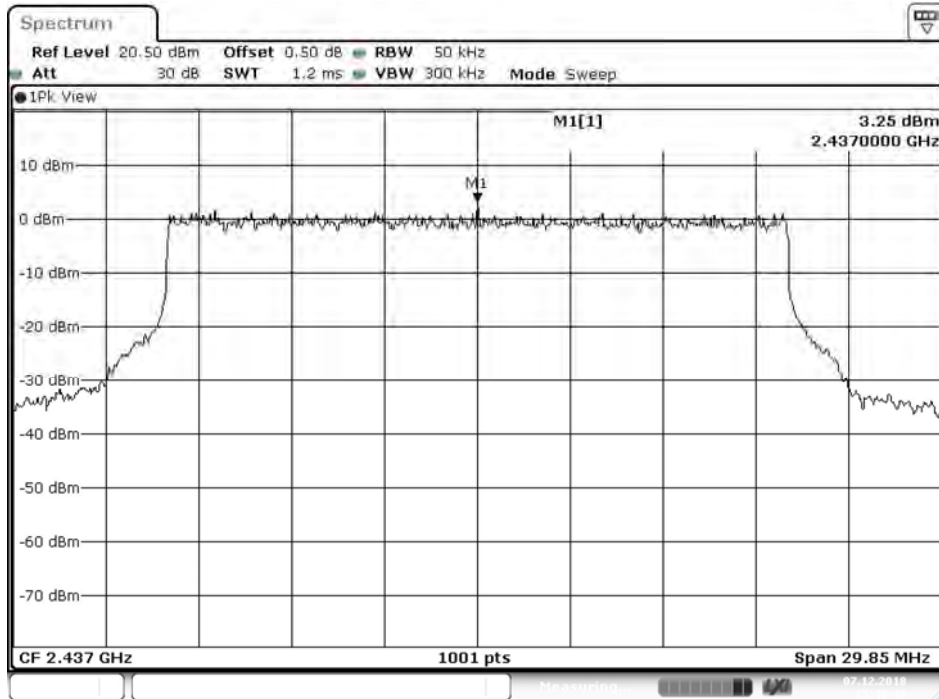

Date: 7.DEC.2018 15:48:48

Figure Channel 06 (Chain B2)

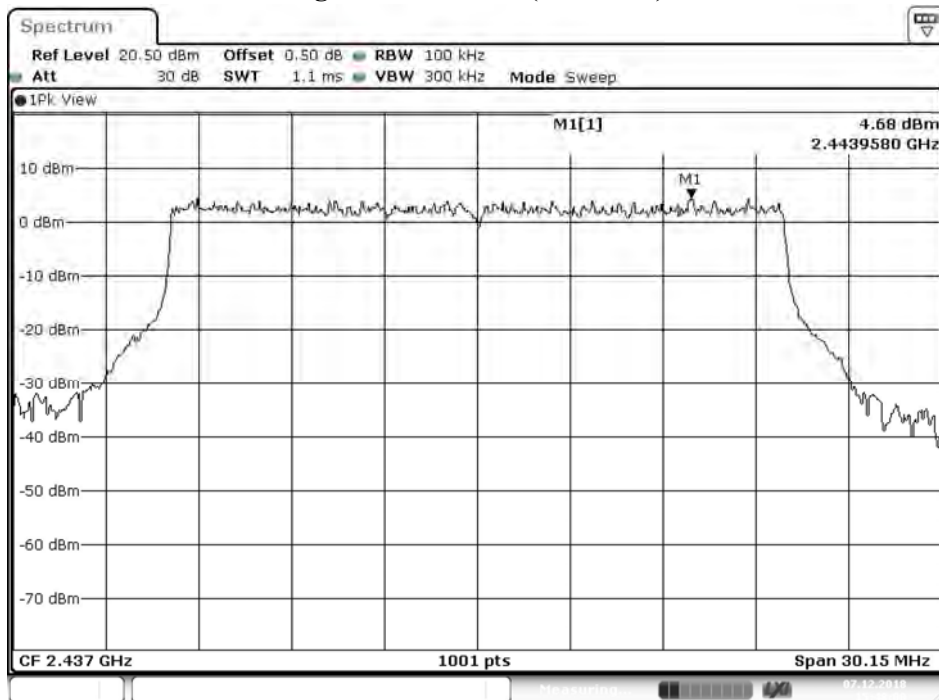

Date: 7.DEC.2018 15:48:00

Figure Channel 11 (Chain B1)

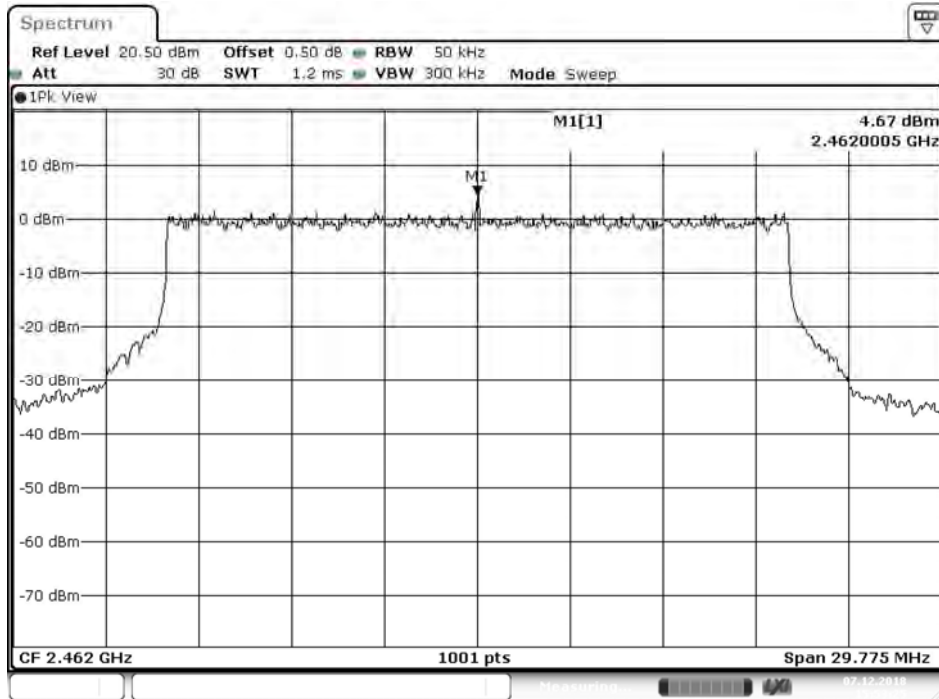

Date: 7.DEC.2018 15:53:25

Figure Channel 11 (Chain B2)

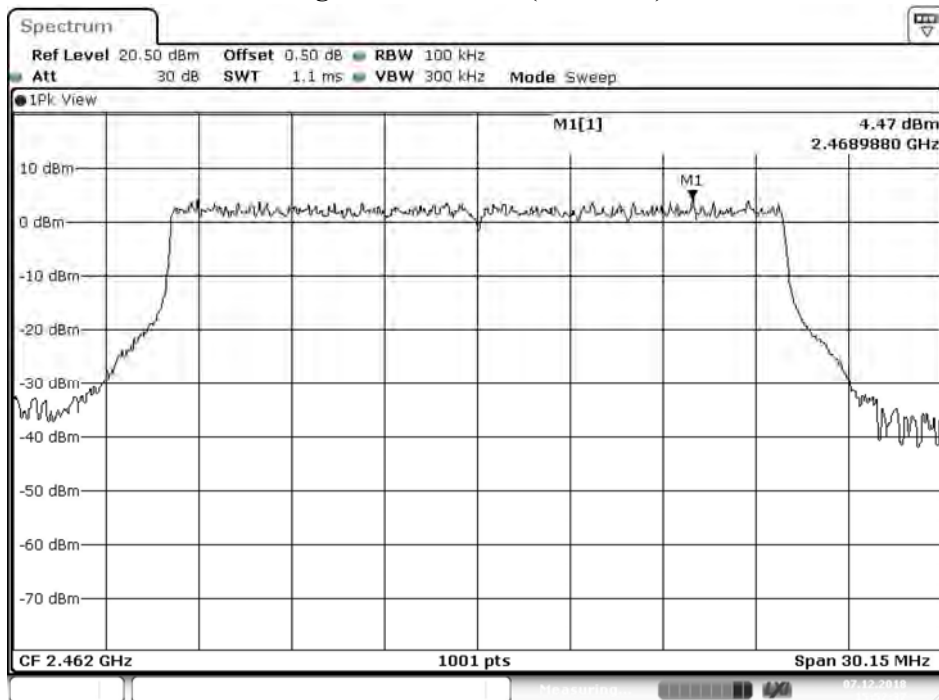

Date: 7.DEC.2018 15:52:36

Product : Software defined radio
 Test Item : Power Density Data
 Test Mode : Mode 2: Transmit_Patch (A1+ A2)

Channel No.	Frequency (MHz)	Chain (dBm)	PPSD/MHz (dBm)	10*log(2) (dB)	Measure Level (dBm)	Limit (dBm)	Result
01	2412	A1	-3.550	3.010	-0.540	≤ 1dBm	Pass
		A2	-3.680	3.010	-0.670	≤ 1dBm	Pass
06	2437	A1	-4.100	3.010	-1.090	≤ 1dBm	Pass
		A2	-3.740	3.010	-0.730	≤ 1dBm	Pass
11	2462	A1	-4.200	3.010	-1.190	≤ 1dBm	Pass
		A2	-4.330	3.010	-1.320	≤ 1dBm	Pass

Note:

1. The quantity $10 \cdot \log 2$ (two antennas) is added to the spectrum peak value according to document 662911 D01.
2. Limit = $8\text{dBm} - (\text{Ant Gain}-6)$; $8\text{dBm} - (13-6) = 1\text{dBm}$

Figure Channel 01 (Chain A1)

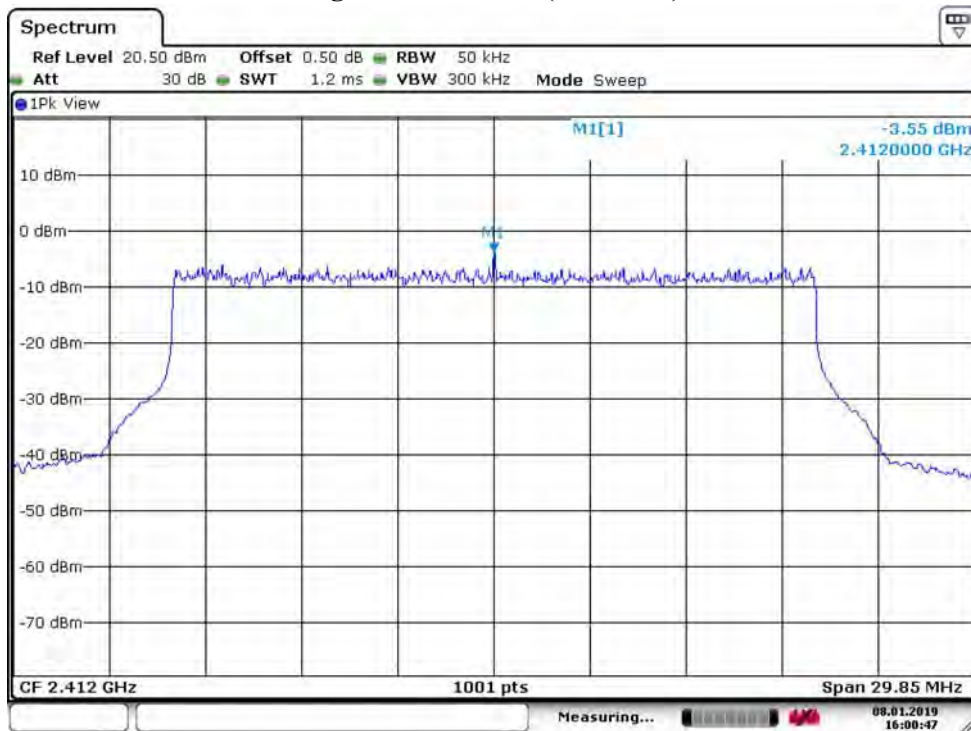
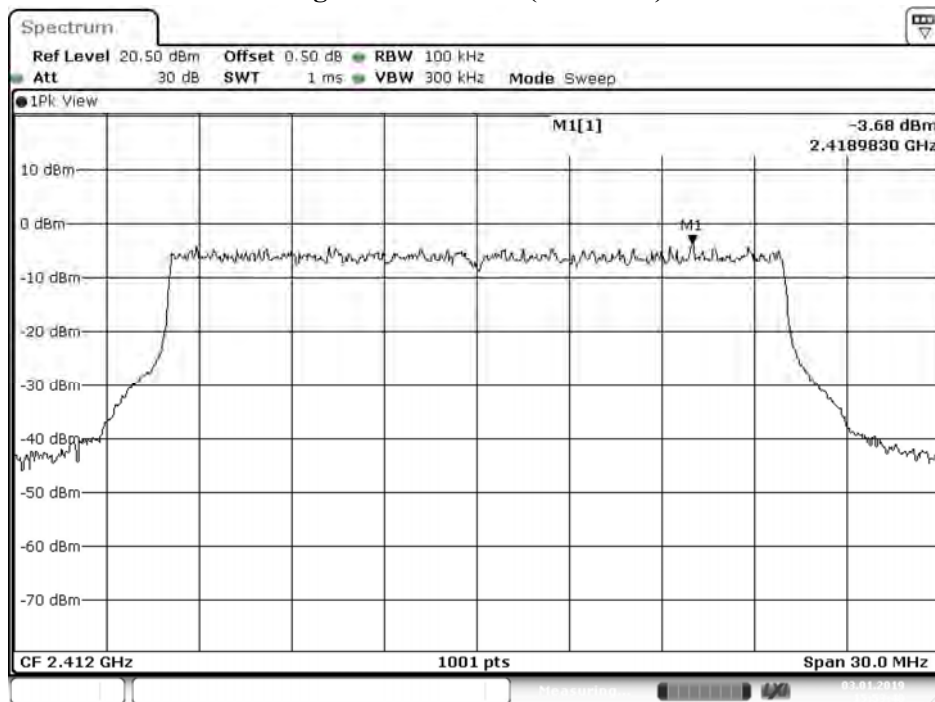

Figure Channel 01 (Chain A2)



Date: 3.JAN.2019 15:53:41

Figure Channel 06 (Chain A1)

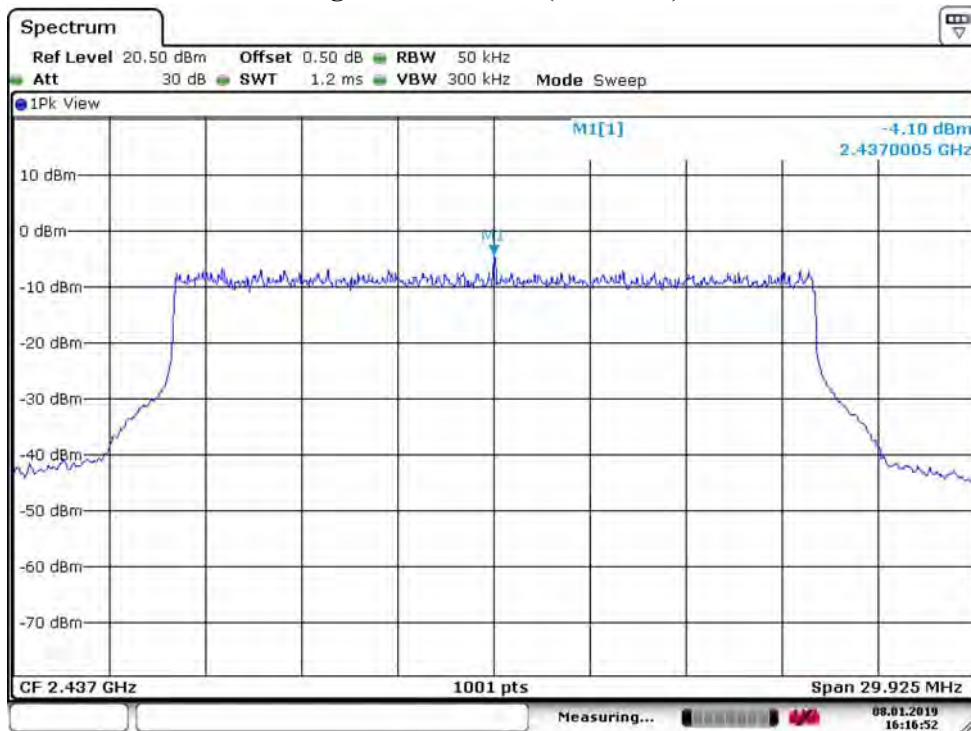
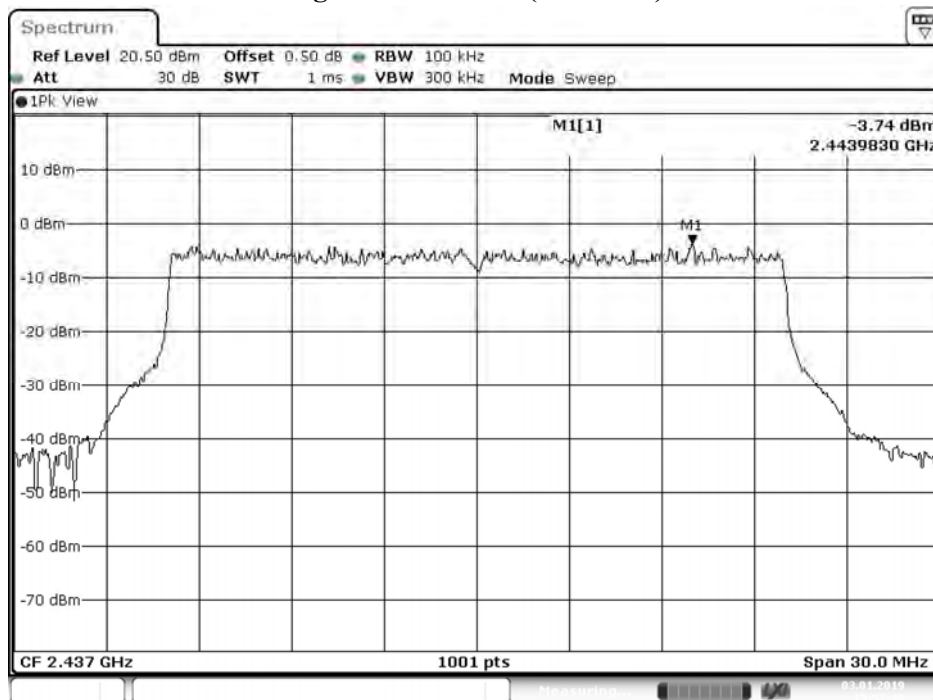

Figure Channel 06 (Chain A2)



Date: 3.JAN.2019 15:57:48

Figure Channel 11 (Chain A1)

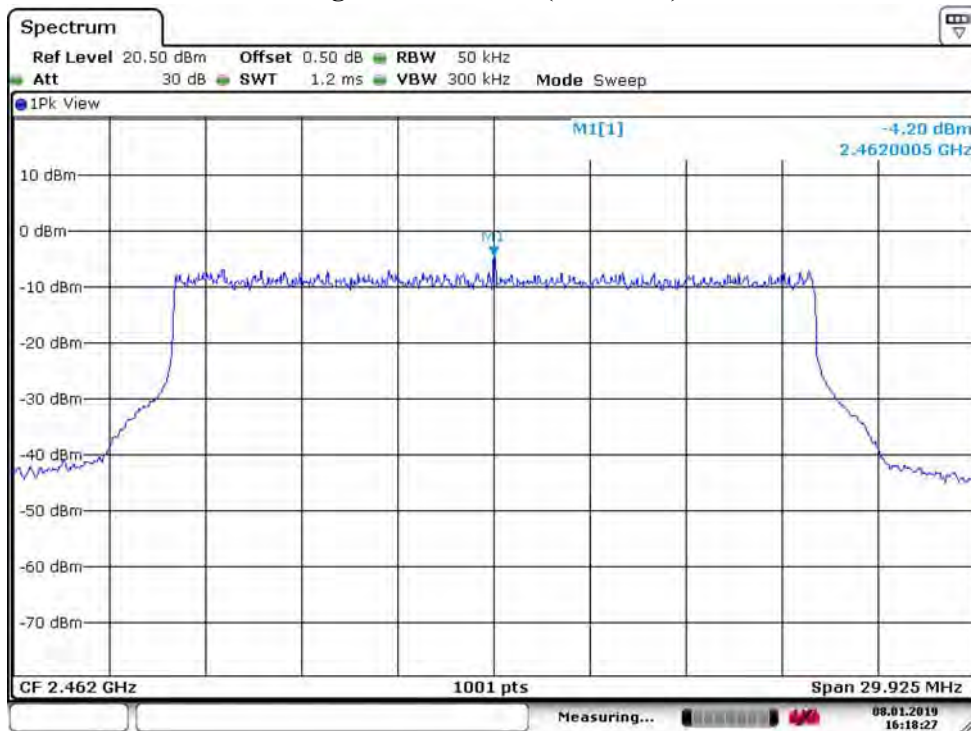
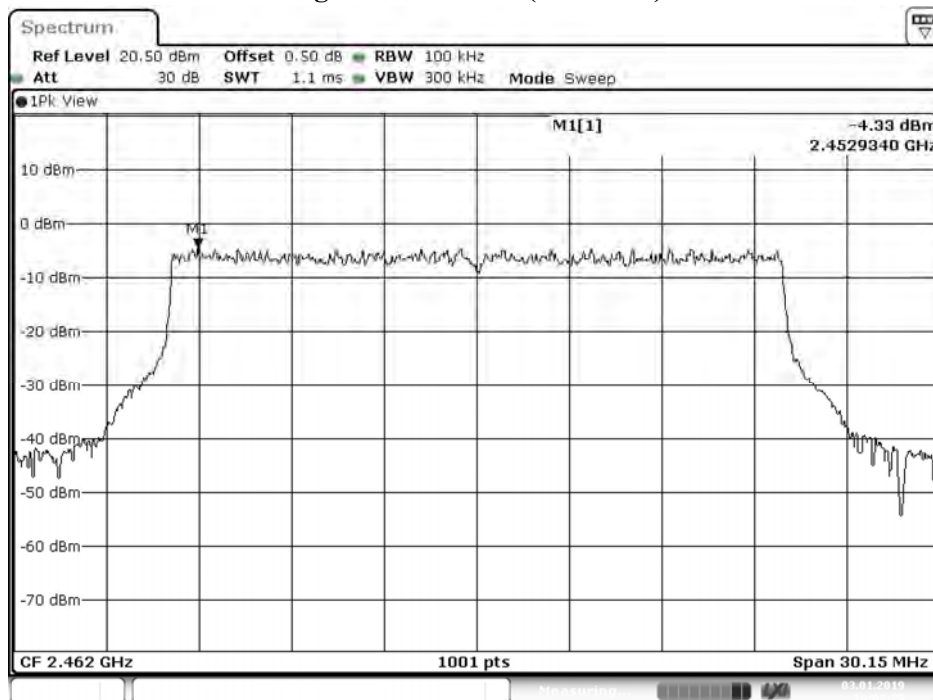

Figure Channel 11 (Chain A2)



Date: 3.JAN.2019 16:02:25

Product : Software defined radio
 Test Item : Power Density Data
 Test Mode : Mode 2: Transmit_Patch (A1+ A2+ B1+ B2)

Channel No.	Frequency (MHz)	Chain (dBm)	PPSD/MHz (dBm)	10*log(4) (dB)	Measure Level (dBm)	Limit (dBm)	Result
01	2412	A1	-5.190	6.021	0.831	$\leq 1\text{dBm}$	Pass
		A2	-6.720	6.021	-0.699	$\leq 1\text{dBm}$	Pass
		B1	-6.750	6.021	-0.729	$\leq 1\text{dBm}$	Pass
		B2	-7.290	6.021	-1.269	$\leq 1\text{dBm}$	Pass
06	2437	A1	-7.050	6.021	-1.029	$\leq 1\text{dBm}$	Pass
		A2	-6.780	6.021	-0.759	$\leq 1\text{dBm}$	Pass
		B1	-6.460	6.021	-0.439	$\leq 1\text{dBm}$	Pass
		B2	-7.510	6.021	-1.489	$\leq 1\text{dBm}$	Pass
11	2462	A1	-6.310	6.021	-0.289	$\leq 1\text{dBm}$	Pass
		A2	-6.730	6.021	-0.709	$\leq 1\text{dBm}$	Pass
		B1	-6.380	6.021	-0.359	$\leq 1\text{dBm}$	Pass
		B2	-7.770	6.021	-1.749	$\leq 1\text{dBm}$	Pass

Note:

- 1.The quantity $10*\log 2$ (two antennas) is added to the spectrum peak value according to document 662911 D01.
2. Limit = $8\text{dBm} - (\text{Ant Gain}-6)$; $8\text{dBm} - (13-6) = 1\text{dBm}$

Figure Channel 01 (Chain A1)

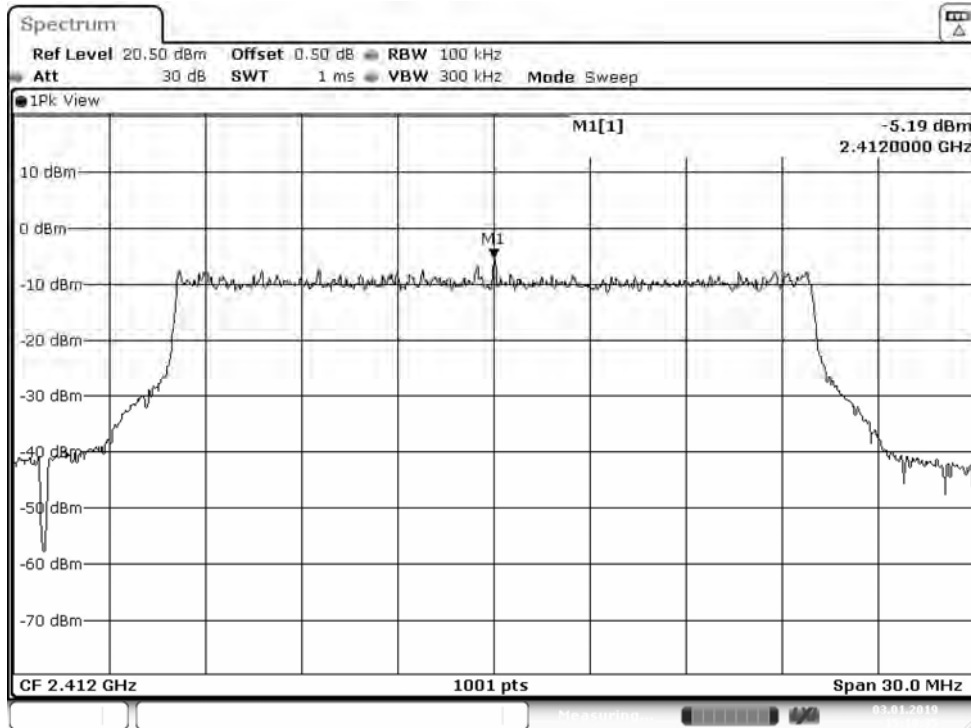
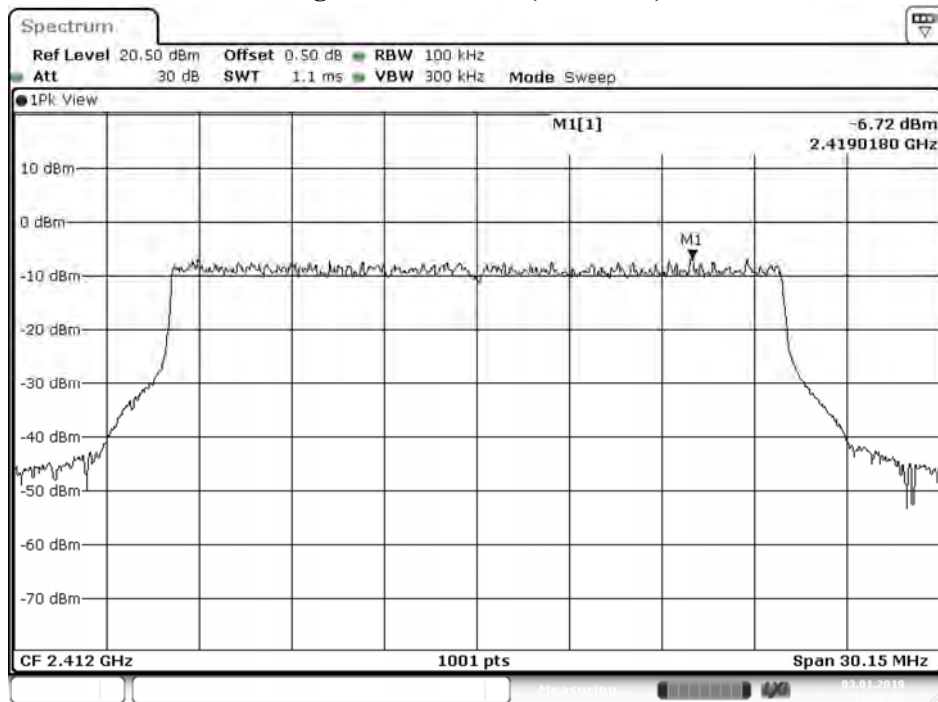

Figure Channel 01 (Chain A2)



Date: 3.JAN.2019 16:56:01

Figure Channel 01 (Chain B1)

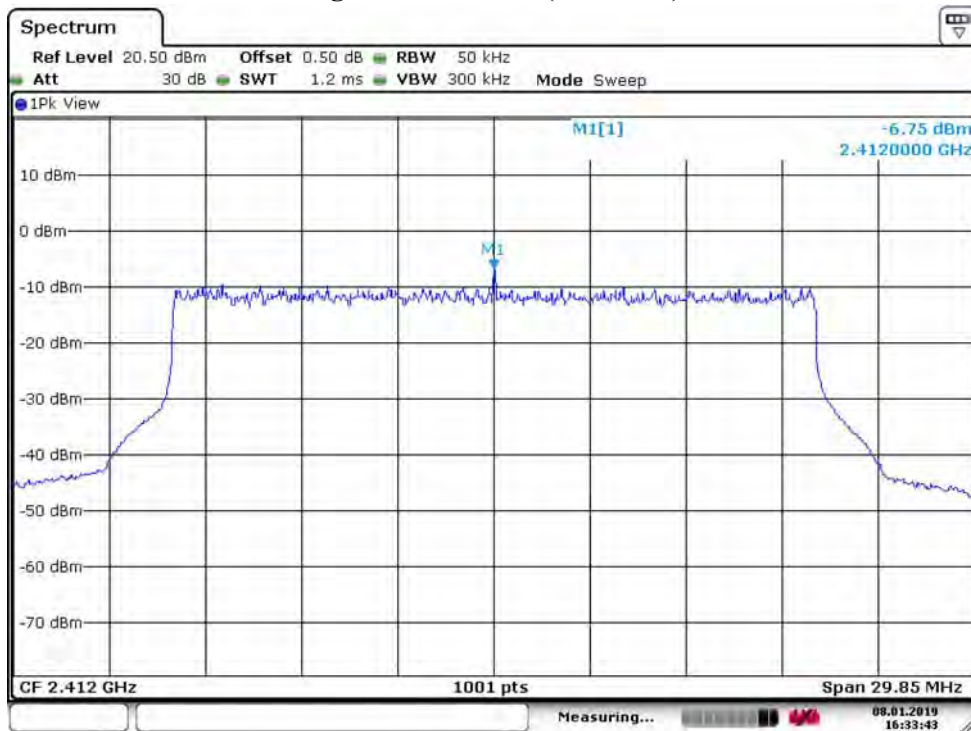
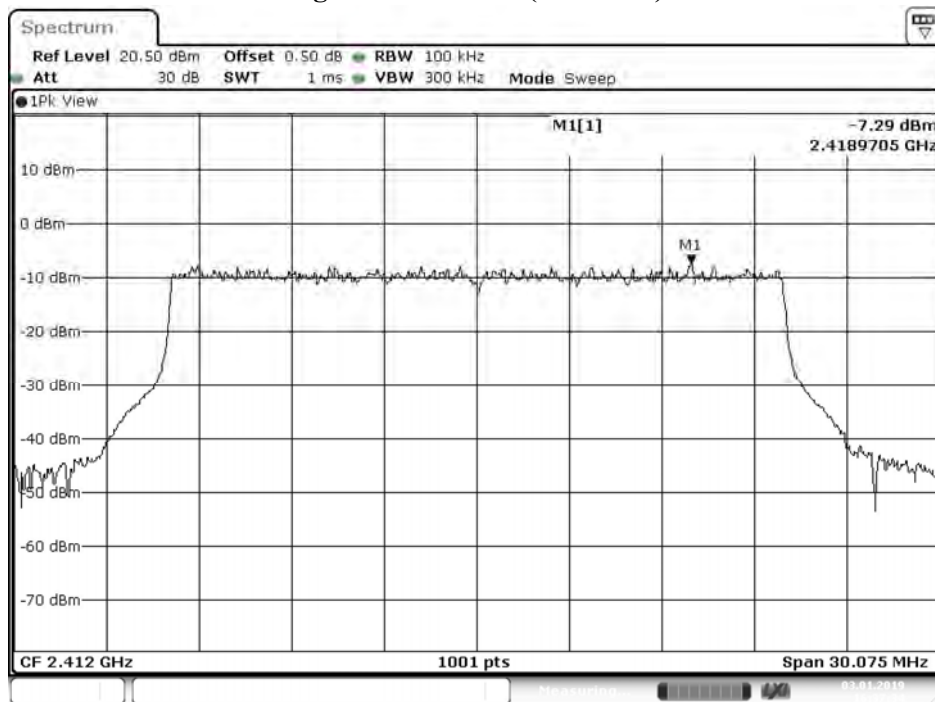

Figure Channel 01 (Chain B2)



Date: 3.JAN.2019 16:37:35

Figure Channel 06 (Chain A1)

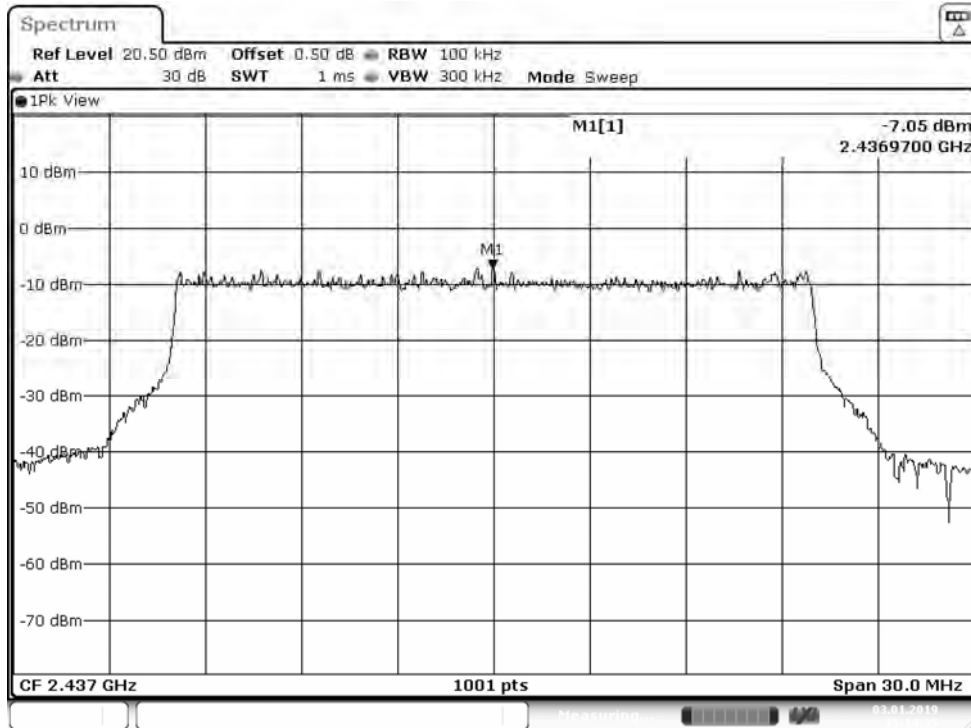
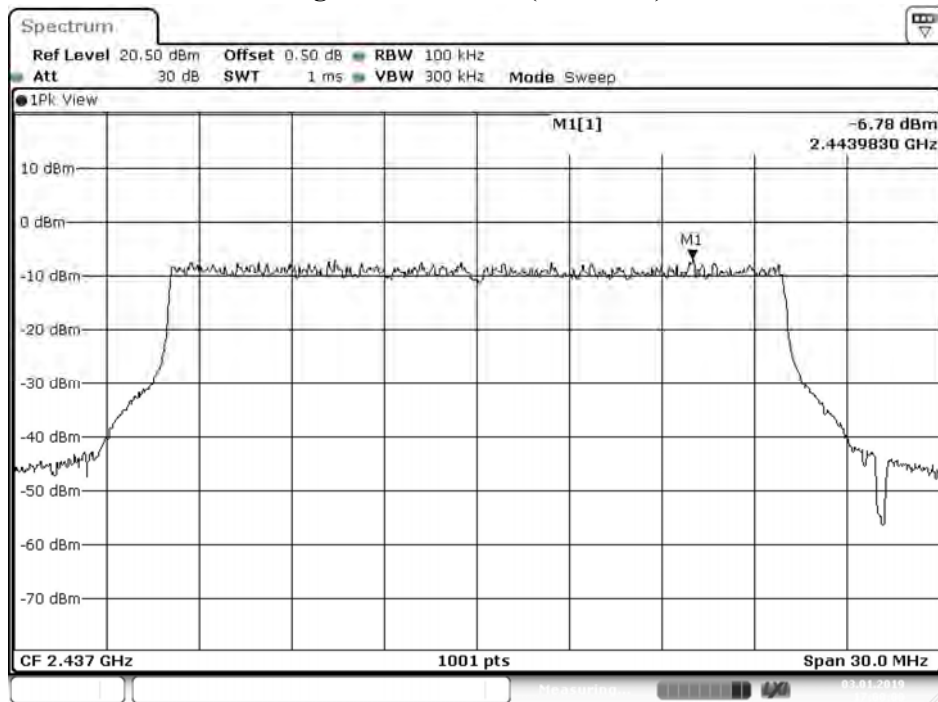

Figure Channel 06 (Chain A2)



Date: 3.JAN.2019 17:00:00

Figure Channel 06 (Chain B1)

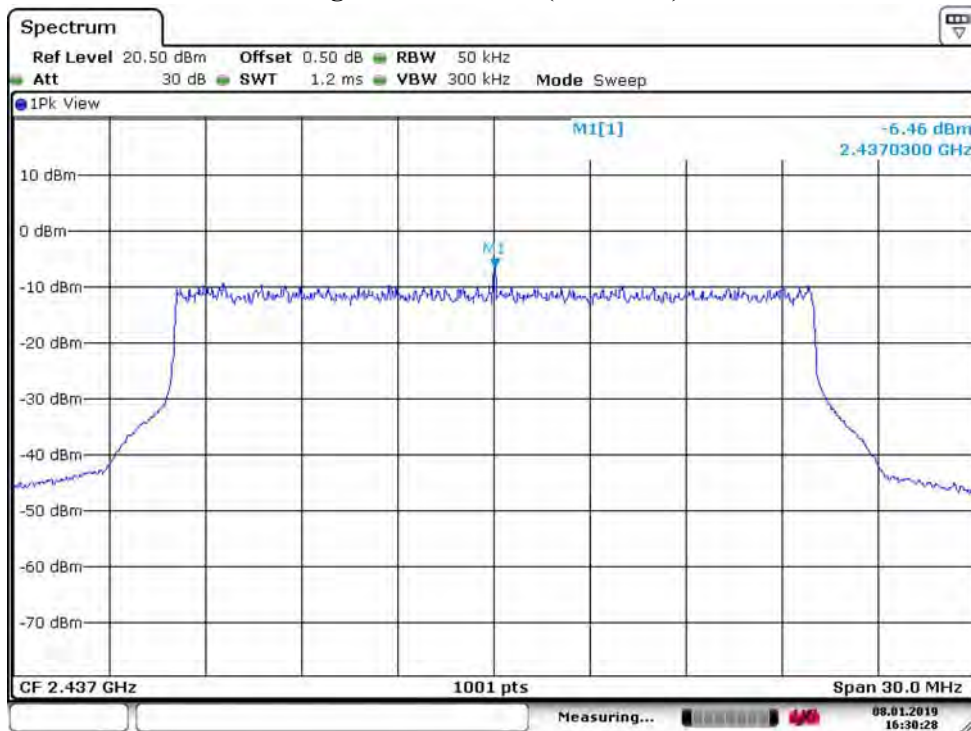
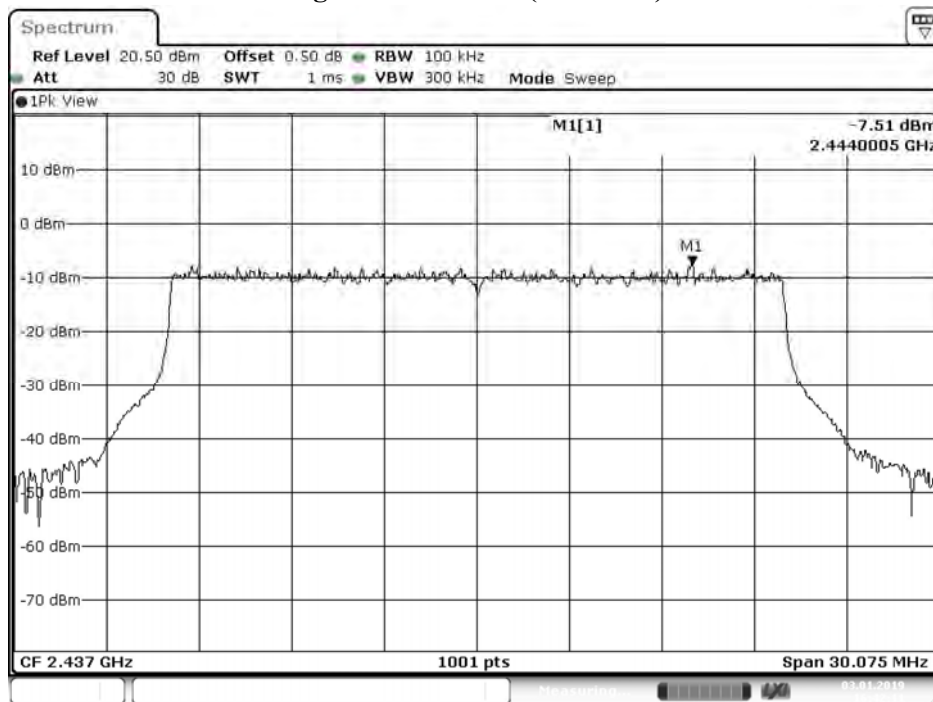

Figure Channel 06 (Chain B2)



Date: 3.JAN.2019 16:42:12

Figure Channel 11 (Chain A1)

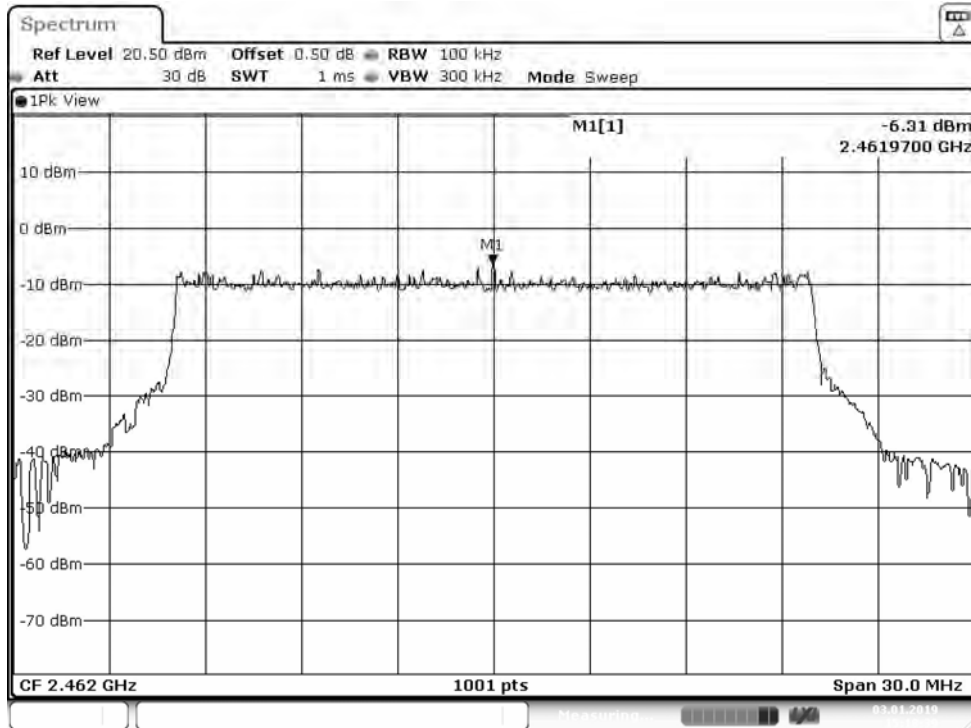
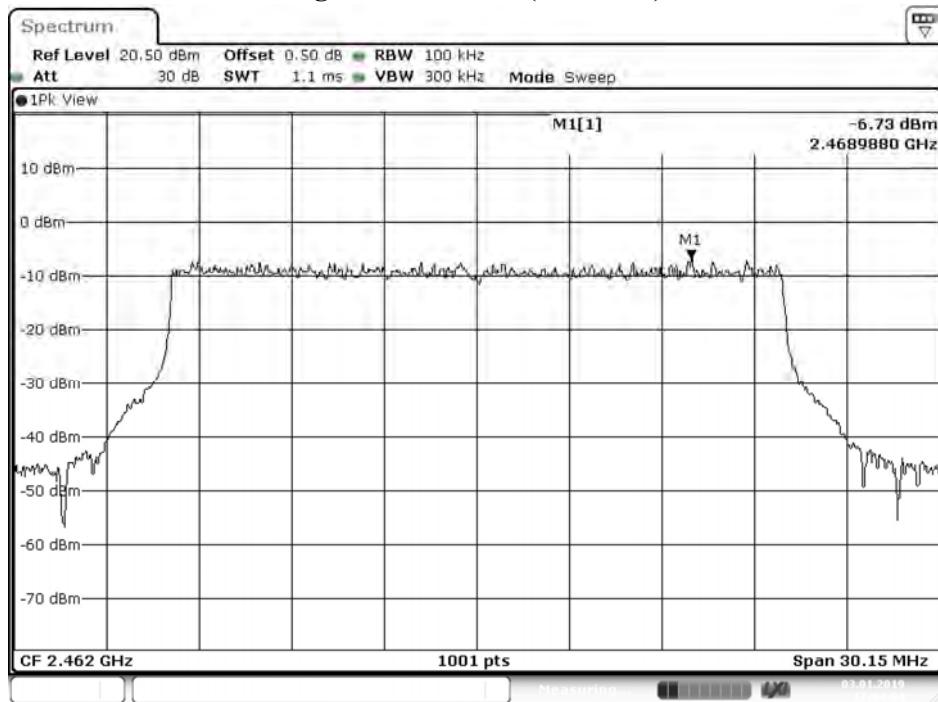

Figure Channel 11 (Chain A2)



Date: 3.JAN.2019 17:04:05

Figure Channel 11 (Chain B1)

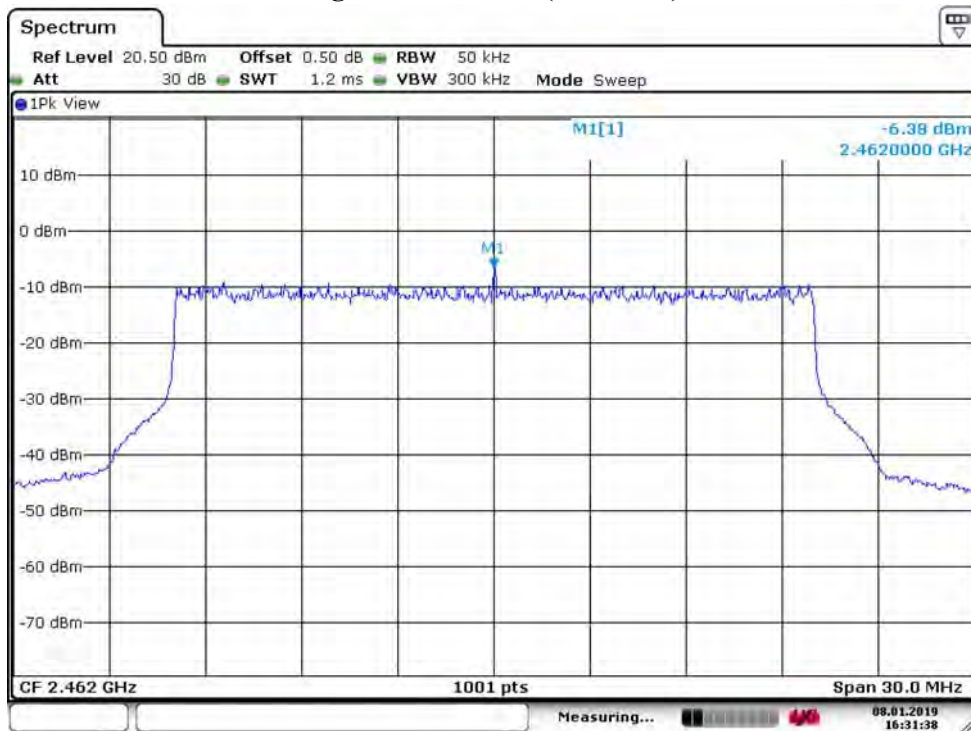
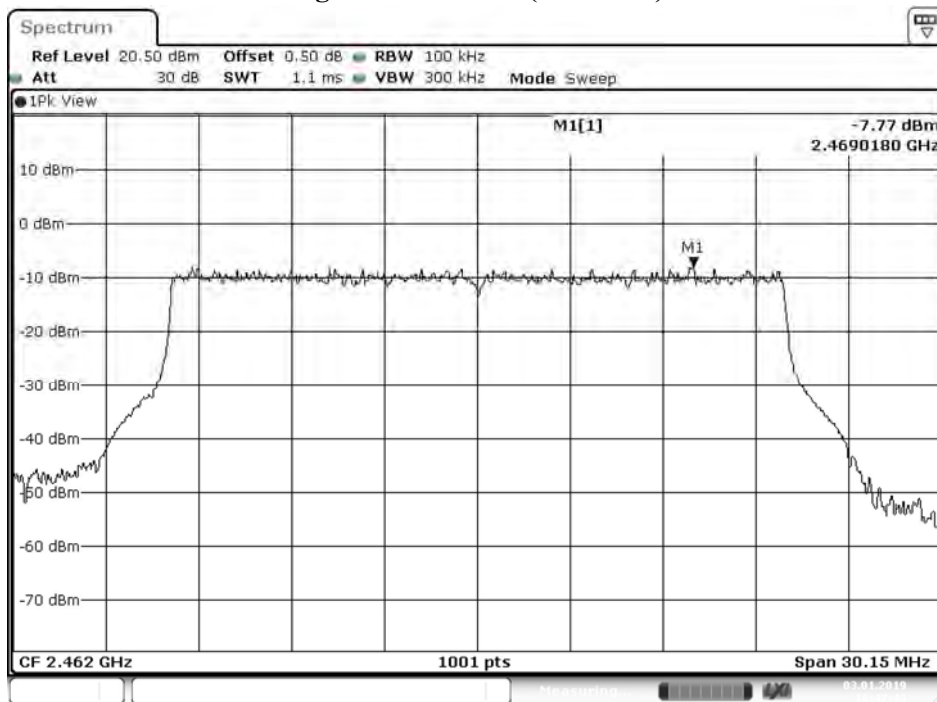

Figure Channel 11 (Chain B2)



Date: 3.JAN.2019 16:47:43

Product : Software defined radio
 Test Item : Power Density Data
 Test Mode : Mode 2: Transmit_Patch (B1+ B2)

Channel No.	Frequency (MHz)	Chain (dBm)	PPSD/MHz (dBm)	10*log(2) (dB)	Measure Level (dBm)	Limit (dBm)	Result
01	2412	B1	-2.770	3.010	0.240	≤ 1dBm	Pass
		B2	-4.210	3.010	-1.200	≤ 1dBm	Pass
06	2437	B1	-2.980	3.010	0.030	≤ 1dBm	Pass
		B2	-4.230	3.010	-1.220	≤ 1dBm	Pass
11	2462	B1	-2.540	3.010	0.470	≤ 1dBm	Pass
		B2	-3.930	3.010	-0.920	≤ 1dBm	Pass

Note:

- 1.The quantity $10*\log 2$ (two antennas) is added to the spectrum peak value according to document 662911 D01.
2. Limit = $8\text{dBm} - (\text{Ant Gain}-6)$; $8\text{dBm} - (13-6) = 1\text{dBm}$

Figure Channel 01 (Chain B1)

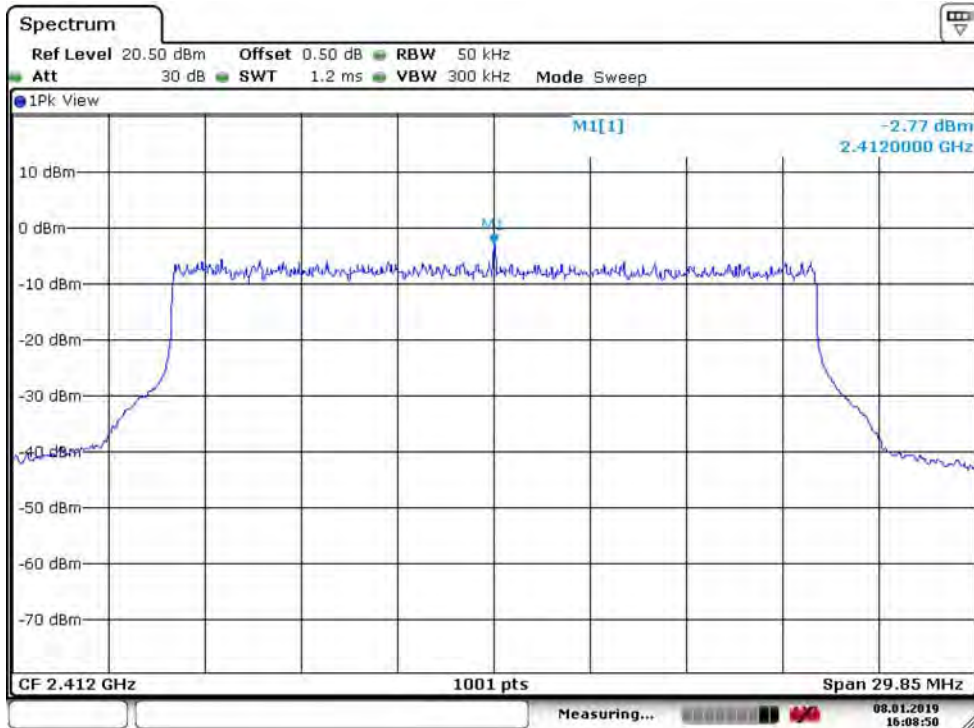
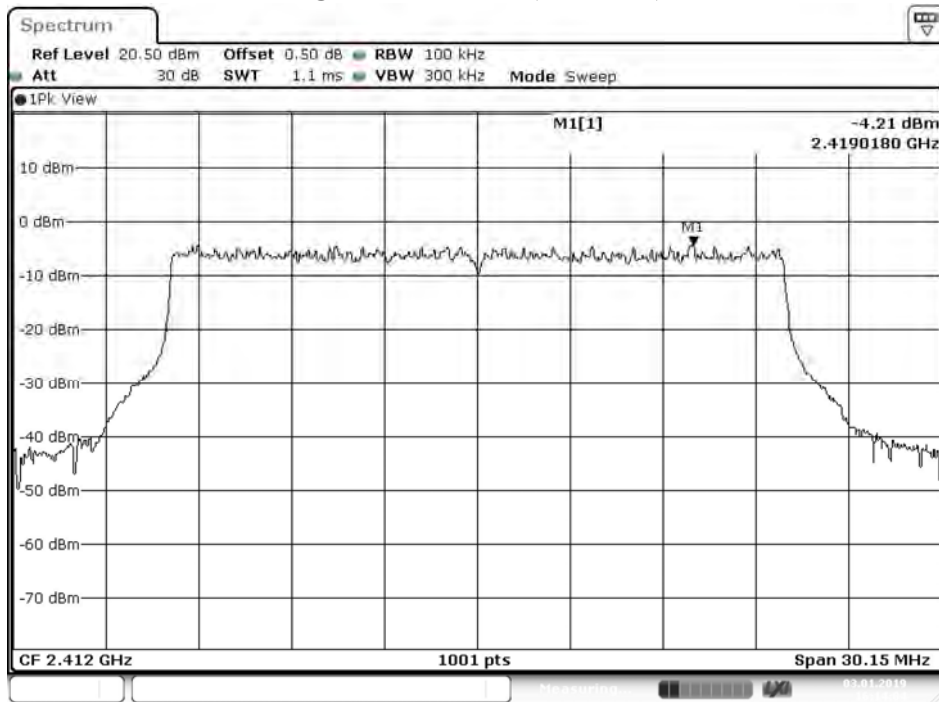

Figure Channel 01 (Chain B2)



Date: 3.JAN.2019 16:14:04

Figure Channel 06 (Chain B1)

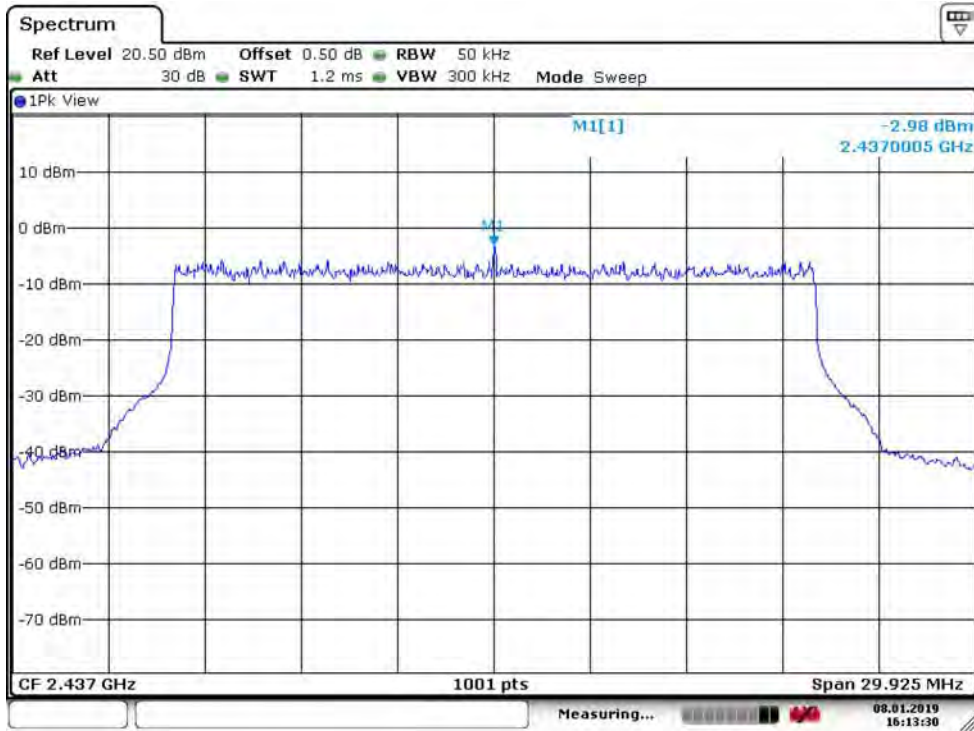
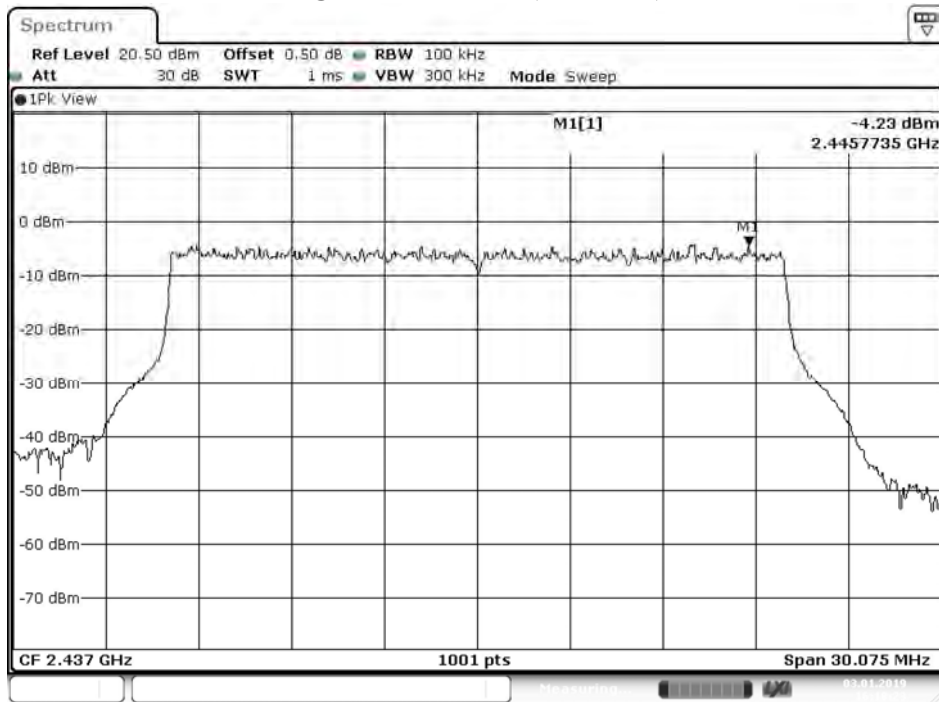

Figure Channel 06 (Chain B2)



Date: 3.JAN.2019 16:18:23

Figure Channel 11 (Chain B1)

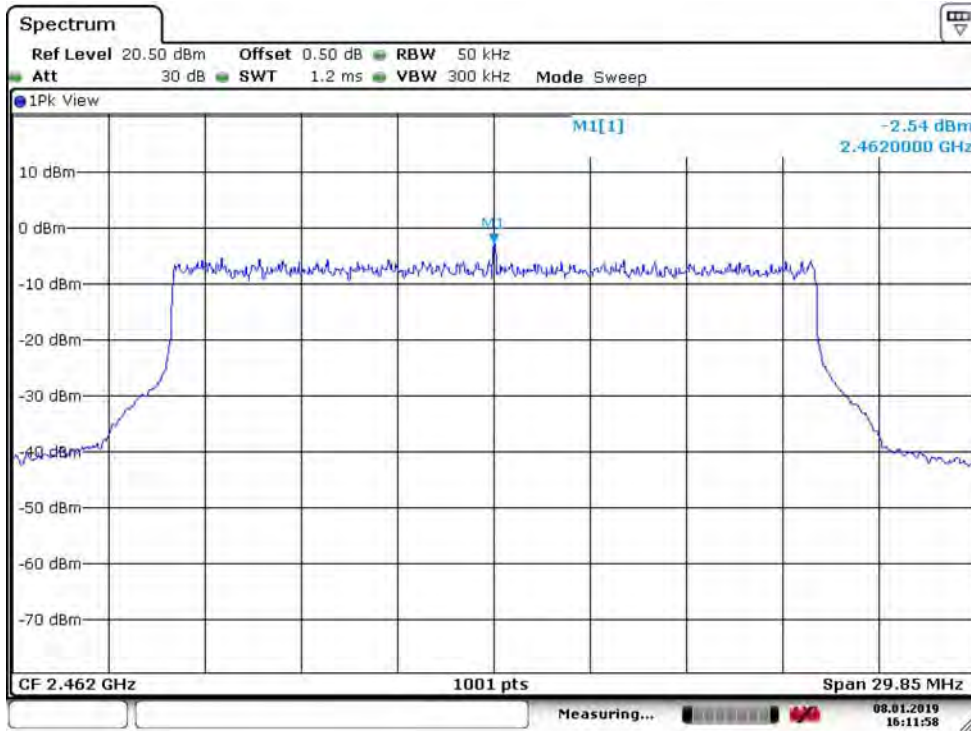
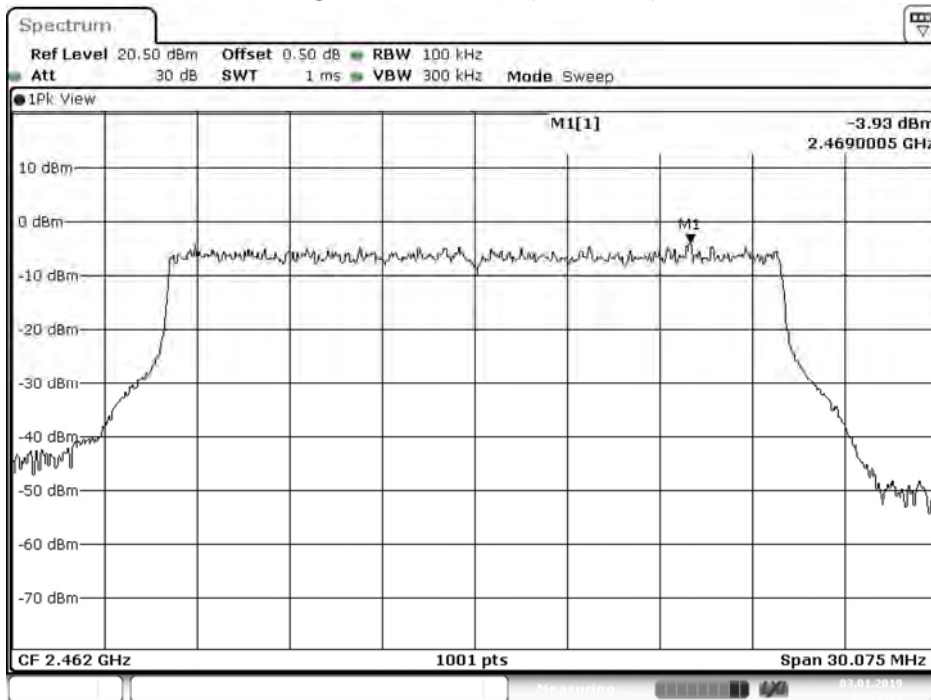

Figure Channel 11 (Chain B2)



Date: 3.JAN.2019 16:22:38

9. Duty Cycle

9.1. Test Setup

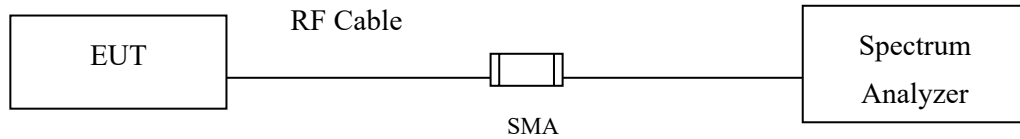

9.2. Test Procedure

The EUT was setup according to ANSI C63.10 2013; tested according to DTS test procedure of KDB558074 for compliance to FCC 47CFR 15.247 requirements.

9.3. Uncertainty

$\pm 2.31\text{msec}$

9.4. Test Result of Duty Cycle

Product : Software defined radio
 Test Item : Duty Cycle

Duty Cycle Formula:

$$\text{Duty Cycle} = \text{Ton} / (\text{Ton} + \text{Toff})$$

$$\text{Duty Factor} = 10 \text{ Log} (1/\text{Duty Cycle})$$

Results:

2.4GHz band	Ton (ms)	Ton + Toff (ms)	Duty Cycle (%)	Duty Factor (dB)
A1, A2	311.5940	311.5940	100.00	0.00
B1, B2	461.5940	461.5940	100.00	0.00
A1, A2, B1, B2	479.7100	479.7100	100.00	0.00

A1, A2

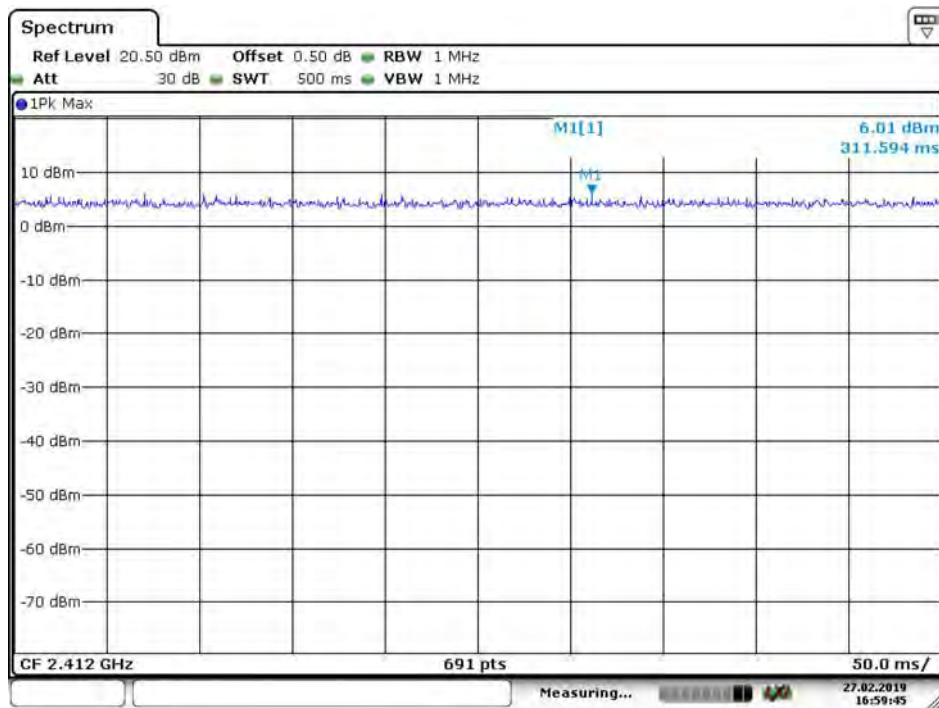

Date: 27.FEB.2019 16:59:45

B1, B2

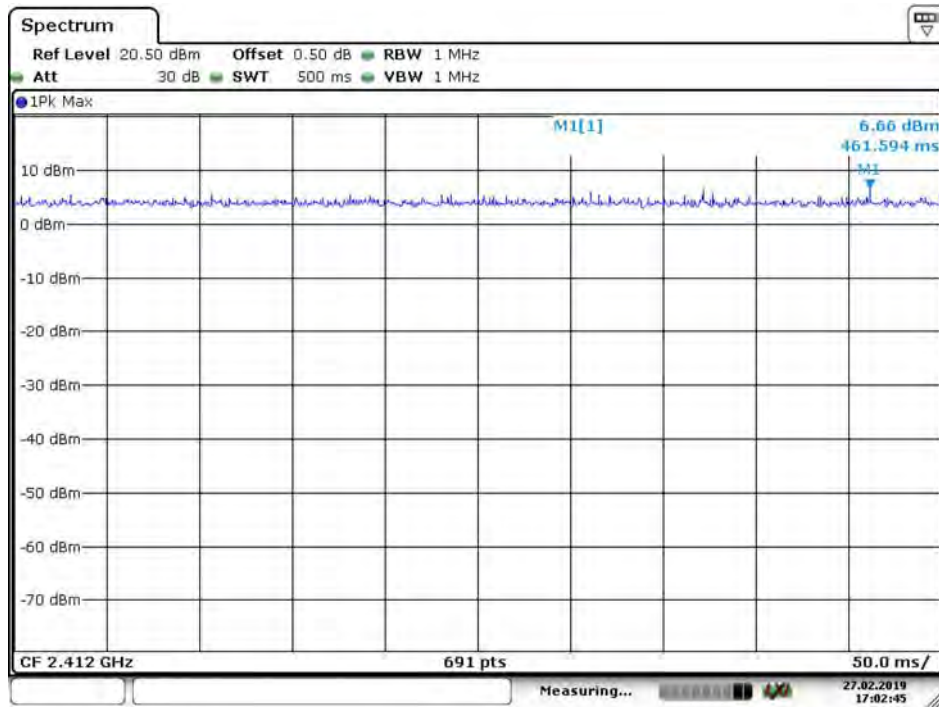

Date: 27.FEB.2019 17:02:45

A1, A2, B1, B2

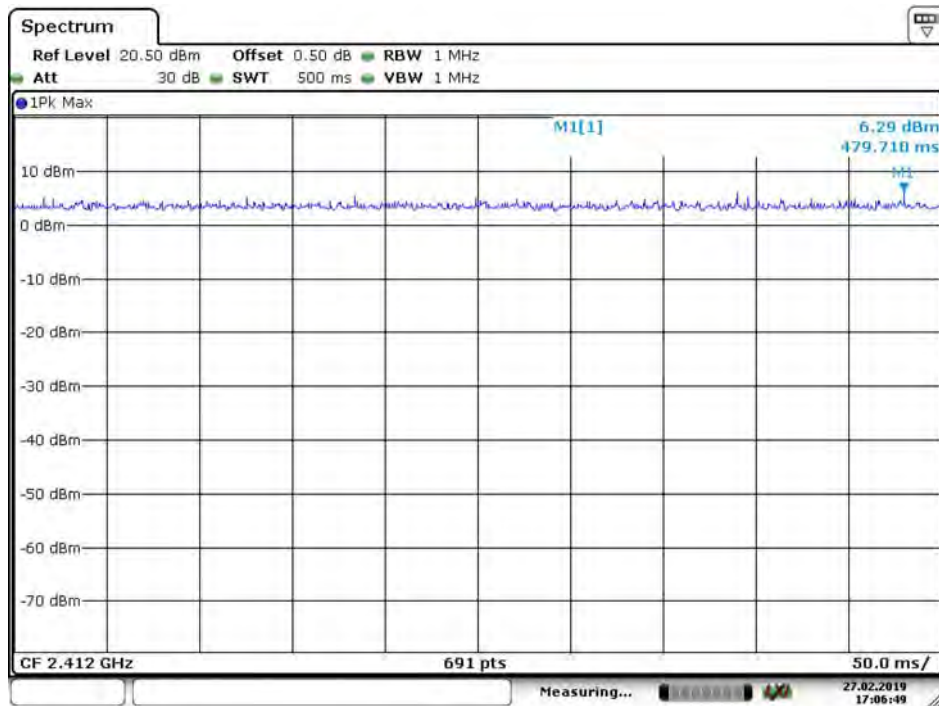

Date: 27.FEB.2019 17:06:49

10. EMI Reduction Method During Compliance Testing

No modification was made during testing.