

# FCC Radio Test Report

**FCC ID: XSG865697**

**Report No.** : BTL-FCCP-1-2201T051  
**Equipment** : control pad  
**Model Name** : BM-RC015-xx  
**Brand Name** : VELUX Touch  
**Applicant** : VELUX America Inc.  
**Address** : PO Box 5001, Greenwood, SC 29648-5001, Greenwood, South Carolina, United States, 29648  
**Manufacturer** : TAIWAN GREEN POINT ENTERPRISES CO LTD JABIL DESIGN SERVICES BRANCH  
**Address** : 7F., No. 413, RuiGuang Rd, Neihu District, TAIPEI 11492, TAIWAN  
**Factory Address** : Jabil Circuit Ukraine LLC  
KONTSIVSKA ST 40, ROZIVKA VILLAGE, UZHGOROD DISTRICT, ZAKARPATSKA OBLAST, UZHGOROD 89424, UKRAINE  
**Radio Function** : Bluetooth Low Energy 5.0  
**FCC Rule Part(s)** : FCC CFR Title 47, Part 15, Subpart C (15.247)  
**Measurement Procedure(s)** : ANSI C63.10-2013  
**Date of Receipt** : 2022/1/17  
**Date of Test** : 2022/1/17 ~ 2022/2/25  
**Issued Date** : 2022/5/5

The above equipment has been tested and found in compliance with the requirement of the above standards by BTL Inc.

**Prepared by** :

Eric Lee, Engineer

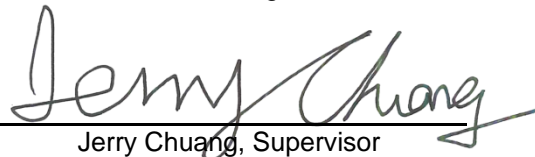
**Approved by** :

Jerry Chuang, Supervisor

**BTL Inc.**

No.18, Ln. 171, Sec. 2, Jiuzong Rd., Neihu Dist., Taipei City 114, Taiwan

Tel: +886-2-2657-3299

Fax: +886-2-2657-3331

Web: www.newbtl.com

**Declaration**

**BTL** represents to the client that testing is done in accordance with standard procedures as applicable and that test instruments used has been calibrated with standards traceable to international standard(s) and/or national standard(s).

**BTL's** reports apply only to the specific samples tested under conditions. It is manufacture's responsibility to ensure that additional production units of this model are manufactured with the identical electrical and mechanical components. **BTL** shall have no liability for any declarations, inferences or generalizations drawn by the client or others from **BTL** issued reports.

This report is the confidential property of the client. As a mutual protection to the clients, the public and ourselves, the test report shall not be reproduced, except in full, without our written approval.

**BTL's** laboratory quality assurance procedures are in compliance with the **ISO/IEC 17025** requirements, and accredited by the conformity assessment authorities listed in this test report.

**BTL** is not responsible for the sampling stage, so the results only apply to the sample as received.

The information, data and test plan are provided by manufacturer which may affect the validity of results, so it is manufacturer's responsibility to ensure that the apparatus meets the essential requirements of applied standards and in all the possible configurations as representative of its intended use.

**Limitation**

For the use of the authority's logo is limited unless the Test Standard(s)/Scope(s)/Item(s) mentioned in this test report is (are) included in the conformity assessment authorities acceptance respective.

Please note that the measurement uncertainty is provided for informational purpose only and are not use in determining the Pass/Fail results.

**CONTENTS**

REVISION HISTORY	5
1 SUMMARY OF TEST RESULTS	6
1.1 TEST FACILITY	7
1.2 MEASUREMENT UNCERTAINTY	7
1.3 TEST ENVIRONMENT CONDITIONS	7
1.4 TABLE OF PARAMETERS OF TEXT SOFTWARE SETTING	8
1.5 DUTY CYCLE	8
2 GENERAL INFORMATION	9
2.1 DESCRIPTION OF EUT	9
2.2 TEST MODES	10
2.3 BLOCK DIAGRAM SHOWING THE CONFIGURATION OF SYSTEM TESTED	11
2.4 SUPPORT UNITS	11
3 RADIATED EMISSIONS TEST	12
3.1 LIMIT	12
3.2 TEST PROCEDURE	13
3.3 DEVIATION FROM TEST STANDARD	13
3.4 TEST SETUP	14
3.5 EUT OPERATING CONDITIONS	15
3.6 TEST RESULT – BELOW 30 MHZ	15
3.7 TEST RESULT – 30 MHZ TO 1 GHZ	15
3.8 TEST RESULT – ABOVE 1 GHZ	15
4 BANDWIDTH TEST	16
4.1 APPLIED PROCEDURES / LIMIT	16
4.2 TEST PROCEDURE	16
4.3 DEVIATION FROM STANDARD	16
4.4 TEST SETUP	16
4.5 EUT OPERATION CONDITIONS	16
4.6 TEST RESULTS	16
5 OUTPUT POWER TEST	17
5.1 APPLIED PROCEDURES / LIMIT	17
5.2 TEST PROCEDURE	17
5.3 DEVIATION FROM STANDARD	17
5.4 TEST SETUP	17
5.5 EUT OPERATION CONDITIONS	17
5.6 TEST RESULTS	17
6 POWER SPECTRAL DENSITY TEST	18
6.1 APPLIED PROCEDURES / LIMIT	18
6.2 TEST PROCEDURE	18
6.3 DEVIATION FROM STANDARD	18
6.4 TEST SETUP	18
6.5 EUT OPERATION CONDITIONS	18
6.6 TEST RESULTS	18
7 ANTENNA CONDUCTED SPURIOUS EMISSION	19
7.1 APPLIED PROCEDURES / LIMIT	19
7.2 TEST PROCEDURE	19
7.3 DEVIATION FROM STANDARD	19
7.4 TEST SETUP	19

7.5	EUT OPERATION CONDITIONS	19
7.6	TEST RESULTS	19
8	LIST OF MEASURING EQUIPMENTS	20
9	EUT TEST PHOTO	21
10	EUT PHOTOS	21
APPENDIX A	RADIATED EMISSIONS - 30 MHZ TO 1 GHZ	22
APPENDIX B	RADIATED EMISSIONS - ABOVE 1 GHZ	25
APPENDIX C	BANDWIDTH	42
APPENDIX D	OUTPUT POWER	45
APPENDIX E	POWER SPECTRAL DENSITY TEST	47
APPENDIX F	ANTENNA CONDUCTED SPURIOUS EMISSION	49

### REVISION HISTORY

Report No.	Version	Description	Issued Date	Note
BTL-FCCP-1-2201T051	R00	Original Report.	2022/5/5	Valid

## 1 SUMMARY OF TEST RESULTS

Test procedures according to the technical standards.

### FCC CFR Title 47, Part 15, Subpart C (15.247)

Standard(s) Section	Description	Test Result	Judgement	Remark
15.207	AC Power Line Conducted Emissions	-----	N/A	-----
15.205 15.209 15.247(d)	Radiated Emissions	APPENDIX A APPENDIX B	Pass	-----
15.247(a)(2)	Bandwidth	APPENDIX C	Pass	-----
15.247(b)(3)	Output Power	APPENDIX D	Pass	-----
15.247(e)	Power Spectral Density	APPENDIX E	Pass	-----
15.247(d)	Antenna conducted Spurious Emission	APPENDIX F	Pass	-----
15.203	Antenna Requirement	-----	Pass	-----

**NOTE:**

- (1) "N/A" denotes test is not applicable in this Test Report.
- (2) The report format version is TP.1.1.1.

### 1.1 TEST FACILITY

The test facilities used to collect the test data in this report:

No. 68-1, Ln. 169, Sec. 2, Datong Rd., Xizhi Dist., New Taipei City 221, Taiwan

The test sites and facilities are covered under FCC RN: 674415 and DN: TW0659.

- C05       CB08       CB11       CB15       CB16  
 SR05

### 1.2 MEASUREMENT UNCERTAINTY

The reported uncertainty of measurement  $y \pm U$ , where expanded uncertainty  $U$  is based on a standard uncertainty multiplied by a coverage factor of  $k = 2$ , providing a level of confidence of approximately **95 %**. The measurement instrumentation uncertainty considerations contained in CISPR 16-4-2. The BTL measurement uncertainty is less than the CISPR 16-4-2  $U_{\text{CISPR}}$  requirement.

#### A. Radiated emissions test :

Test Site	Measurement Frequency Range	U,(dB)
CB15	0.03 GHz ~ 0.2 GHz	4.17
	0.2 GHz ~ 1 GHz	4.72
	1 GHz ~ 6 GHz	5.21
	6 GHz ~ 18 GHz	5.51
	18 GHz ~ 26 GHz	3.69
	26 GHz ~ 40 GHz	4.23

#### B. Conducted test :

Test Item	U,(dB)
Occupied Bandwidth	0.5334
Output power	0.3669
Power Spectral Density	0.6591
Conducted Spurious emissions	0.5416
Conducted Band edges	0.5348

#### NOTE:

Unless specifically mentioned, the uncertainty of measurement has not been taken into account to declare the compliance or non-compliance to the specification.

### 1.3 TEST ENVIRONMENT CONDITIONS

Test Item	Environment Condition	Test Voltage	Tested by
Radiated emissions below 1 GHz	21 °C, 68 %	DC 3V	Vincent Lee
Radiated emissions above 1 GHz	20 °C, 62 %	DC 3V	Vincent Lee
Bandwidth	22.8 °C, 52 %	DC 3V	Angela Wang
Output Power	22.8 °C, 52 %	DC 3V	Angela Wang
Power Spectral Density	22.8 °C, 52 %	DC 3V	Angela Wang
Antenna conducted Spurious Emission	22.8 °C, 52 %	DC 3V	Angela Wang

## 1.4 TABLE OF PARAMETERS OF TEXT SOFTWARE SETTING

Test Software	CMD			
Modulation Mode	2402 MHz	2440 MHz	2480 MHz	Data Rate
BLE 5.0	109	113	117	1 Mbps
BLE 5.0	110	114	70	2 Mbps

## 1.5 DUTY CYCLE

If duty cycle is  $\geq 98\%$ , duty factor is not required.  
 If duty cycle is  $< 98\%$ , duty factor shall be considered.

Remark	Delta 1			Delta 2	On Time/Period	10 log(1/Duty Cycle)
Mode	ON (ms)	Numbers (ON)	On Time (B) (ms)	Period (ON+OFF) (ms)	Duty Cycle (%)	Duty Factor (dB)
BLE 5.0 (1 Mbps)	1.000	1	1.000	1.000	100.00%	0.00
BLE 5.0 (2 Mbps)	1.000	1	1.000	1.000	100.00%	0.00

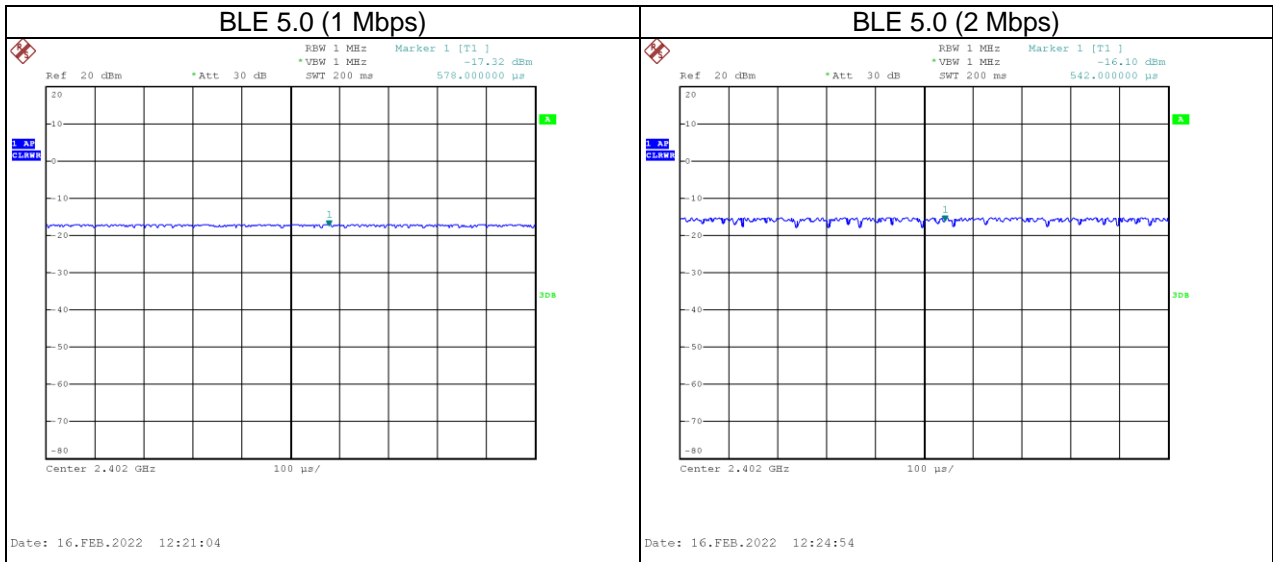



## 2 GENERAL INFORMATION

### 2.1 DESCRIPTION OF EUT

Equipment	control pad
Model Name	BM-RC015-xx
Brand Name	VELUX Touch
Model Difference	The last 2 digits "xx" in the model number, this is used internally in VELUX to describe the version of the device: 01 – 99
Power Source	Battery supplied.
Power Rating	DC 3.2-1.8V
Products Covered	N/A
Operation Band	2400 MHz ~ 2483.5 MHz
Operation Frequency	2402 MHz ~ 2480 MHz
Modulation Technology	GFSK
Transfer Rate	1/2 Mbps
Output Power Max.	1 Mbps: 10.10 dBm (0.0102 W) 2 Mbps: 10.07 dBm (0.0102 W)
Test Model	BM-RC015-01
Sample Status	Engineering Sample
EUT Modification(s)	N/A

**NOTE:**

- (1) For a more detailed features description, please refer to the manufacturer's specifications or the user's manual.
- (2) Channel List:

Channel	Frequency (MHz)	Channel	Frequency (MHz)
00	2402	20	2442
01	2404	21	2444
02	2406	22	2446
03	2408	23	2448
04	2410	24	2450
05	2412	25	2452
06	2414	26	2454
07	2416	27	2456
08	2418	28	2458
09	2420	29	2460
10	2422	30	2462
11	2424	31	2464
12	2426	32	2466
13	2428	33	2468
14	2430	34	2470
15	2432	35	2472
16	2434	36	2474
17	2436	37	2476
18	2438	38	2478
19	2440	39	2480

- (3) Table for Filed Antenna:

Antenna	Brand name	Model name	Type	Connector	Gain (dBi)
1	Jabil	2G4_ANT	PIFA	I-PEX	-0.38

## 2.2 TEST MODES

Test Items	Test mode	Channel	Note
Transmitter Radiated Emissions (below 1GHz)	2 Mbps	39	-
Transmitter Radiated Emissions (above 1GHz)	1, 2 Mbps	00/39	Bandedge
	1, 2 Mbps	00/19/39	Harmonic
Bandwidth	1 Mbps	00/19/39	-
Output Power	1 Mbps	00/19/39	-
Power Spectral Density	1 Mbps	00/19/39	-
Antenna conducted Spurious Emission	1 Mbps	00/19/39	-

**NOTE:**

- (1) For radiated emission band edge test, both Vertical and Horizontal are evaluated, but only the worst case (Horizontal) is recorded.
- (2) All X, Y and Z axes are evaluated, but only the worst case (X axis) is recorded.

### 2.3 BLOCK DIAGRAM SHOWING THE CONFIGURATION OF SYSTEM TESTED

Equipment letters and Cable numbers refer to item numbers described in the tables of clause 2.4.

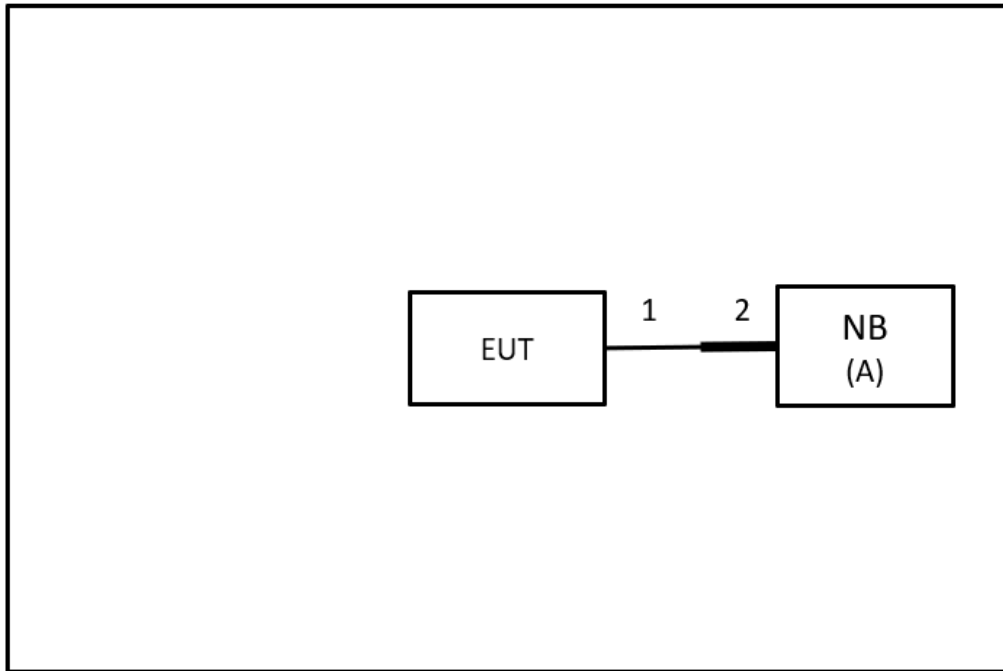

### 2.4 SUPPORT UNITS

Item	Equipment	Brand	Model No.	Series No.	Remarks
A	NB	HP	TPN-I119	N/A	Furnished by test lab.

Item	Shielded	Ferrite Core	Length	Cable Type	Remarks
1	N/A	N/A	0.35m	Fixture Cable	Supplied by test requester.
2	N/A	N/A	3m	USB extension Cable	Furnished by test lab.

### 3 RADIATED EMISSIONS TEST

#### 3.1 LIMIT

In case the emission fall within the restricted band specified on 15.205, then the 15.209 limit in the table below has to be followed.

#### LIMITS OF RADIATED EMISSIONS MEASUREMENT (9 kHz to 1000 MHz)

Frequency (MHz)	Field Strength (microvolts/meter)	Measurement Distance (meters)
0.009~0.490	2400/F(KHz)	300
0.490~1.705	24000/F(KHz)	30
1.705~30.0	30	30
30~88	100	3
88~216	150	3
216~960	200	3
960~1000	500	3

#### LIMITS OF RADIATED EMISSIONS MEASUREMENT (Above 1000 MHz)

Frequency (MHz)	Radiated Emissions (dBuV/m)		Measurement Distance (meters)
	Peak	Average	
Above 1000	74	54	3

#### NOTE:

- (1) The limit for radiated test was performed according to FCC Part 15, Subpart C.
- (2) The tighter limit applies at the band edges.
- (3) Emission level (dBuV/m)=20log Emission level (uV/m).
- (4) The test result calculated as following:

Measurement Value = Reading Level + Correct Factor

Correct Factor = Antenna Factor + Cable Loss - Amplifier Gain(if use)

Margin Level = Measurement Value - Limit Value

Calculation example:

Reading Level		Correct Factor	=	Measurement Value
41.91	+	-8.36	=	33.55

Measurement Value		Limit Value	=	Margin Level
33.55	-	43.50	=	-9.95

Spectrum Parameter	Setting
Attenuation	Auto
Start Frequency	1000 MHz
Stop Frequency	10th carrier harmonic
RBW / VBW (Emission in restricted band)	1MHz / 3MHz for Peak, 1MHz / 1/T for Average

Spectrum Parameter	Setting
Attenuation	Auto
Start ~ Stop Frequency	9KHz~90KHz for PK/AVG detector
Start ~ Stop Frequency	90KHz~110KHz for QP detector
Start ~ Stop Frequency	110KHz~490KHz for PK/AVG detector
Start ~ Stop Frequency	490KHz~30MHz for QP detector
Start ~ Stop Frequency	30MHz~1000MHz for QP detector

### 3.2 TEST PROCEDURE

- a. The measuring distance of 3 m shall be used for measurements. The EUT was placed on the top of a rotating table 0.8 meter above the ground at a 3 meter semi-anechoic chamber. The table was rotated 360 degrees to determine the position of the highest radiation.(below 1GHz)
- b. The measuring distance of 3 m shall be used for measurements. The EUT was placed on the top of a rotating table 1.5 meter above the ground at a 3 meter semi-anechoic chamber. The table was rotated 360 degrees to determine the position of the highest radiation.(above 1GHz)
- c. The height of the equipment or of the substitution antenna shall be 0.8 m or 1.5 m, the height of the test antenna shall vary between 1 m to 4 m. Both horizontal and vertical polarizations of the antenna are set to make the measurement.
- d. For each suspected emission, the EUT was arranged to its worst case and then the antenna was tuned to heights find the maximum reading (used Bore sight function).
- e. The receiver system was set to peak and average detect function and specified bandwidth with maximum hold mode when the test frequency is above 1GHz.
- f. The initial step in collecting radiated emission data is a receiver peak detector mode pre-scanning the measurement frequency range. Significant peaks are then marked and then Quasi Peak detector mode re-measured.
- g. All readings are Peak unless otherwise stated QP in column of Note. Peak denotes that the Peak reading compliance with the QP Limits and then QP Mode measurement didn't perform. (below 1GHz)
- h. All readings are Peak Mode value unless otherwise stated AVG in column of Note. If the Peak Mode Measured value compliance with the Peak Limits and lower than AVG Limits, the EUT shall be deemed to meet both Peak & AVG Limits and then only Peak Mode was measured, but AVG Mode didn't perform. (above 1GHz)
- i. For the actual test configuration, please refer to the related Item – EUT TEST PHOTO.

### 3.3 DEVIATION FROM TEST STANDARD

No deviation.

### 3.4 TEST SETUP

#### 30 MHz to 1 GHz

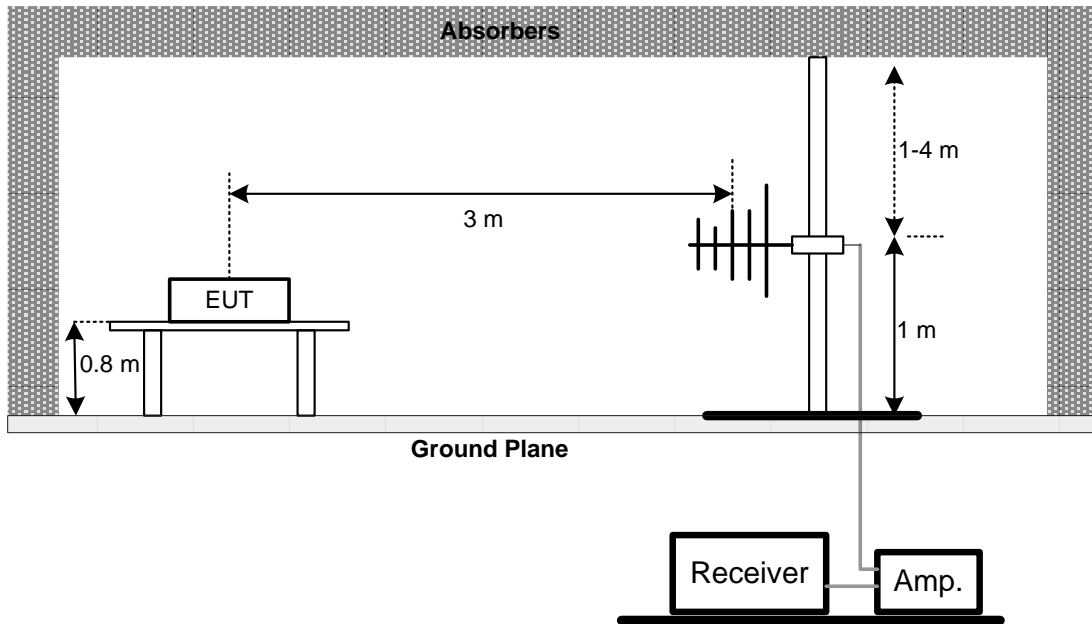

#### Above 1 GHz

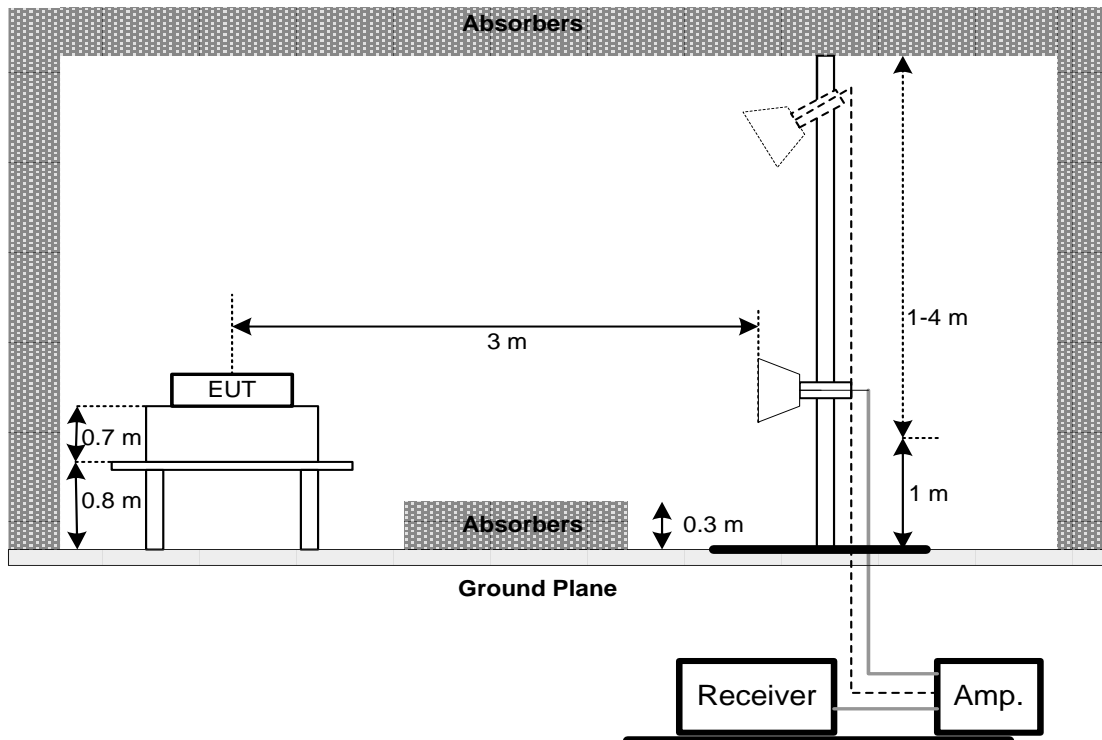

**3.5 EUT OPERATING CONDITIONS**

The EUT was programmed to be in continuously transmitting mode.

**3.6 TEST RESULT – BELOW 30 MHZ**

There were no emissions found below 30 MHz within 20 dB of the limit.

**3.7 TEST RESULT – 30 MHZ TO 1 GHZ**

Please refer to the APPENDIX A.

**3.8 TEST RESULT – ABOVE 1 GHZ**

Please refer to the APPENDIX B.

**NOTE:**

- (1) No limit: This is fundamental signal, the judgment is not applicable.  
For fundamental signal judgment was referred to Peak output test.

## 4 BANDWIDTH TEST

### 4.1 APPLIED PROCEDURES / LIMIT

FCC Part15 (15.247) , Subpart C				
Section	Test Item	Limit	Frequency Range (MHz)	Result
15.247(a)(2)	Bandwidth	>= 500KHz (6dB bandwidth)	2400-2483.5	PASS

### 4.2 TEST PROCEDURE

- a. The EUT was directly connected to the spectrum analyzer and antenna output port as show in the block diagram below,
- b. Spectrum Setting : RBW= 100KHz, VBW=300KHz, Sweep time = 2.5 ms.

### 4.3 DEVIATION FROM STANDARD

No deviation.

### 4.4 TEST SETUP

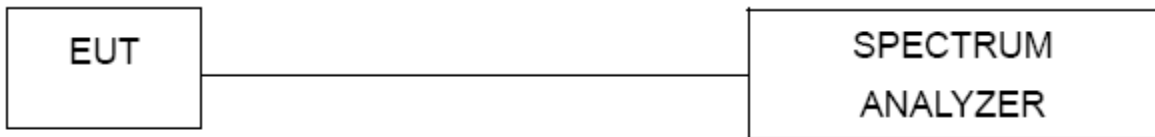

### 4.5 EUT OPERATION CONDITIONS

The EUT tested system was configured as the statements of 3.5 unless otherwise a special operating condition is specified in the follows during the testing.

### 4.6 TEST RESULTS

Please refer to the APPENDIX C.



**5 OUTPUT POWER TEST**

**5.1 APPLIED PROCEDURES / LIMIT**

FCC Part15 (15.247) , Subpart C				
Section	Test Item	Limit	Frequency Range (MHz)	Result
15.247(b)(3)	Maximum Output Power	1 watt or 30dBm	2400-2483.5	PASS

**5.2 TEST PROCEDURE**

- a. The EUT was directly connected to the power meter and antenna output port as show in the block diagram below,
- b. The maximum peak conducted output power was performed in accordance with FCC KDB 558074 D01 15.247 Meas Guidance.

**5.3 DEVIATION FROM STANDARD**

No deviation.

**5.4 TEST SETUP**

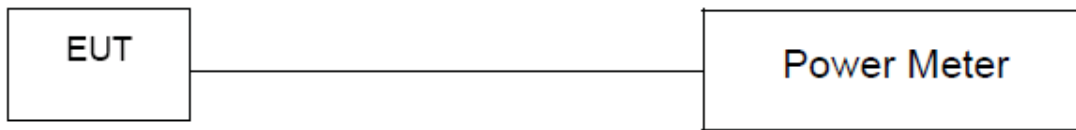

**5.5 EUT OPERATION CONDITIONS**

The EUT tested system was configured as the statements of 3.5 unless otherwise a special operating condition is specified in the follows during the testing.

**5.6 TEST RESULTS**

Please refer to the APPENDIX D.

**6 POWER SPECTRAL DENSITY TEST**

**6.1 APPLIED PROCEDURES / LIMIT**

FCC Part15 (15.247) , Subpart C				
Section	Test Item	Limit	Frequency Range (MHz)	Result
15.247(e)	Power Spectral Density	8 dBm (in any 3KHz)	2400-2483.5	PASS

**6.2 TEST PROCEDURE**

- a. The EUT was directly connected to the spectrum analyzer and antenna output port as show in the block diagram below,
- b. Spectrum Setting: RBW=3KHz, VBW=10 KHz, Sweep time = auto.

**6.3 DEVIATION FROM STANDARD**

No deviation.

**6.4 TEST SETUP**



**6.5 EUT OPERATION CONDITIONS**

The EUT tested system was configured as the statements of 3.5 unless otherwise a special operating condition is specified in the follows during the testing.

**6.6 TEST RESULTS**

Please refer to the APPENDIX E.

## 7 ANTENNA CONDUCTED SPURIOUS EMISSION

### 7.1 APPLIED PROCEDURES / LIMIT

In any 100 kHz bandwidth outside the frequency band in which the spread spectrum or digitally modulated device is operating, the RF power that is produced shall be at least 20 dB below that in the 100 kHz bandwidth within the band that contains the highest level of the desired power, based on either an RF conducted or a radiated measurement, provided that the transmitter demonstrates compliance with the peak conducted power limits.

### 7.2 TEST PROCEDURE

- a. The EUT was directly connected to the spectrum analyzer and antenna output port as show in the block diagram below,
- b. Spectrum Setting : RBW= 100KHz, VBW=300KHz, Sweep time = 10 ms.

### 7.3 DEVIATION FROM STANDARD

No deviation.

### 7.4 TEST SETUP



### 7.5 EUT OPERATION CONDITIONS

The EUT tested system was configured as the statements of 3.5 unless otherwise a special operating condition is specified in the follows during the testing.

### 7.6 TEST RESULTS

Please refer to the APPENDIX F.

## 8 LIST OF MEASURING EQUIPMENTS

Radiated Emissions						
Item	Kind of Equipment	Manufacturer	Type No.	Serial No.	Calibrated Date	Calibrated Until
1	Preamplifier	EMCI	EMC02325	980217	2021/4/8	2022/4/7
2	Preamplifier	EMCI	EMC012645SE	980737	2021/12/6	2022/12/5
3	Preamplifier	EMCI	EMC001340	980555	2021/4/8	2022/4/7
4	Test Cable	EMCI	EMC104-SM-1000	180809	2021/4/8	2022/4/7
5	Test Cable	EMCI	EMC104-SM-SM-3000	151205	2021/4/8	2022/4/7
6	Test Cable	EMCI	EMC-SM-SM-7000	180408	2021/4/8	2022/4/7
7	MXE EMI Receiver	Agilent	N9038A	MY56400087	2021/5/27	2022/5/26
8	Signal Analyzer	Agilent	N9010A	MY56480554	2021/8/25	2022/8/24
9	Loop Ant	Electro-Metrics	EMCI-LPA600	274	2021/6/1	2022/5/31
10	Horn Ant	SCHWARZBECK	BBHA 9120D	9120D-1342	2021/6/2	2022/6/1
11	Horn Ant	Schwarzbeck	BBHA 9170	340	2021/7/9	2022/7/8
12	Trilog-Broadband Antenna	Schwarzbeck	VULB 9168	9168-352	2021/8/11	2022/8/10
13	5dB Attenuator	EMCI	EMCI-N-6-05	AT-N0625	2021/8/11	2022/8/10
14	Measurement Software	EZ	EZ EMC (Version NB-03A1-01)	N/A	N/A	N/A

Bandwidth						
Item	Kind of Equipment	Manufacturer	Type No.	Serial No.	Calibrated Date	Calibrated Until
1	Spectrum Analyzer	R&S	FSP38	101139	2021/3/5	2022/3/4

Output Power						
Item	Kind of Equipment	Manufacturer	Type No.	Serial No.	Calibrated Date	Calibrated Until
1	Power Meter	Anritsu	ML2495A	1128008	2021/5/26	2022/5/25
2	Power Sensor	Anritsu	MA2411B	1126001	2021/5/26	2022/5/25

Power Spectral Density						
Item	Kind of Equipment	Manufacturer	Type No.	Serial No.	Calibrated Date	Calibrated Until
1	Spectrum Analyzer	R&S	FSP38	101139	2021/3/5	2022/3/4

Antenna conducted Spurious Emission						
Item	Kind of Equipment	Manufacturer	Type No.	Serial No.	Calibrated Date	Calibrated Until
1	Spectrum Analyzer	R&S	FSP38	101139	2021/3/5	2022/3/4

Remark: "N/A" denotes no model name, no serial no. or no calibration specified.  
All calibration period of equipment list is one year.

**9 EUT TEST PHOTO**

Please refer to document Appendix No.: TP-2201T051-FCCP-1 (APPENDIX-TEST PHOTOS).

**10 EUT PHOTOS**

Please refer to document Appendix No.: EP-2201T051-2 (APPENDIX-EUT PHOTOS).

## **APPENDIX A    RADIATED EMISSIONS - 30 MHZ TO 1 GHZ**

Test Mode	BLE 5.0 (2 Mbps)	Test Date	2022/2/22
Test Frequency	2480MHz	Polarization	Vertical
Temp	21°C	Hum.	68%

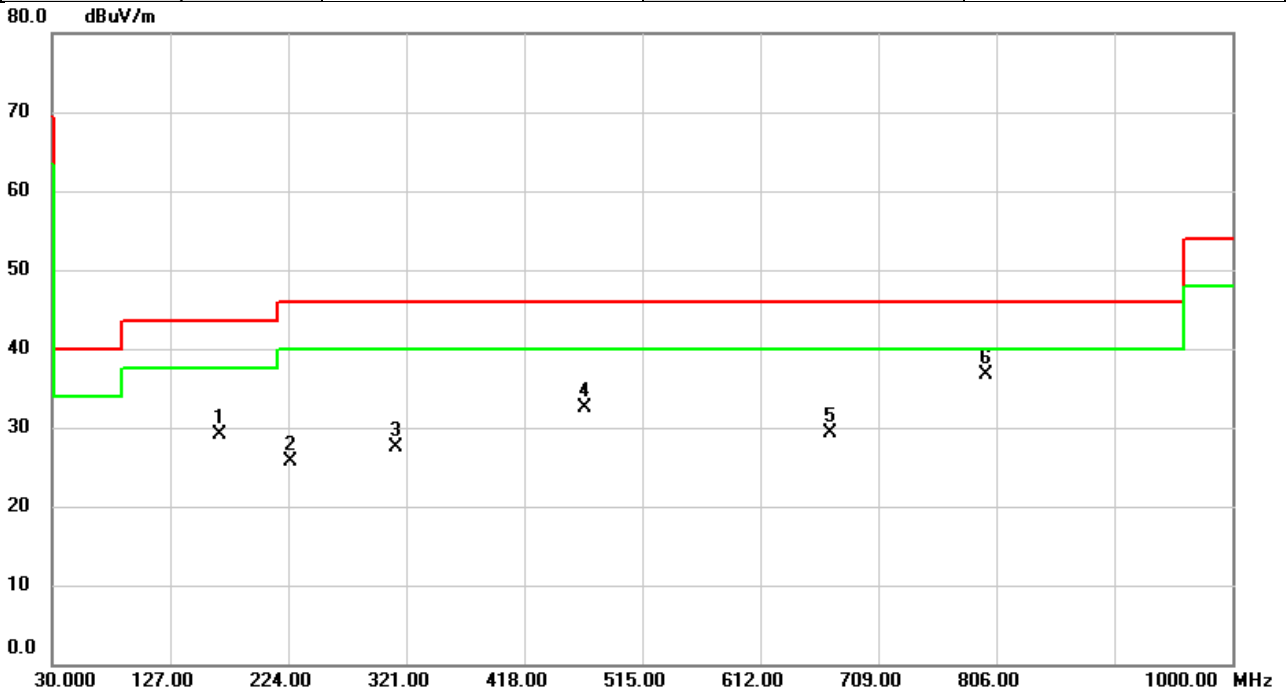

No.	Mk.	Freq.	Reading Level	Correct Factor	Measurement	Limit	Over	Detector	Comment
		MHz	dBuV	dB	dBuV/m	dBuV/m	dB		
1		167.9986	38.38	-9.32	29.06	43.50	-14.44	peak	
2		225.6811	37.87	-12.10	25.77	46.00	-20.23	peak	
3		312.0113	35.51	-8.01	27.50	46.00	-18.50	peak	
4		467.6315	36.54	-4.12	32.42	46.00	-13.58	peak	
5		669.6503	29.40	-0.15	29.25	46.00	-16.75	peak	
6	*	797.5932	34.69	1.92	36.61	46.00	-9.39	peak	

**REMARKS:**

- (1) Measurement Value = Reading Level + Correct Factor.
- (2) Margin Level = Measurement Value - Limit Value.

Test Mode	BLE 5.0 (2 Mbps)	Test Date	2022/2/22
Test Frequency	2480MHz	Polarization	Horizontal
Temp	21°C	Hum.	68%

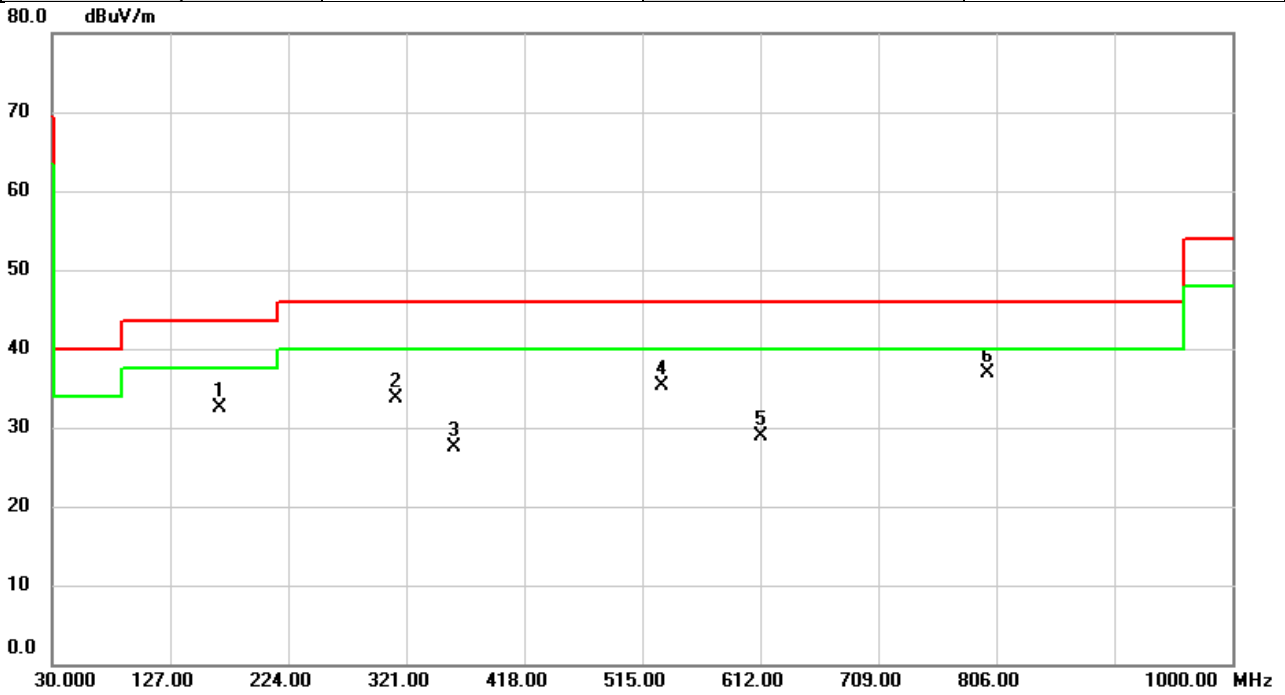

No.	Mk.	Freq.	Reading Level	Correct Factor	Measurement	Limit	Over	Detector	Comment
		MHz	dBuV	dB	dBuV/m	dBuV/m	dB		
1		167.9986	41.79	-9.32	32.47	43.50	-11.03	peak	
2		312.0113	41.76	-8.01	33.75	46.00	-12.25	peak	
3		359.9940	34.59	-7.00	27.59	46.00	-18.41	peak	
4		530.9080	38.35	-3.03	35.32	46.00	-10.68	peak	
5		613.2933	29.70	-0.85	28.85	46.00	-17.15	peak	
6	*	798.7250	34.90	1.93	36.83	46.00	-9.17	peak	

**REMARKS:**

- (1) Measurement Value = Reading Level + Correct Factor.
- (2) Margin Level = Measurement Value - Limit Value.



## **APPENDIX B RADIATED EMISSIONS - ABOVE 1 GHZ**

Test Mode	BLE 5.0 (1 Mbps)	Test Date	2022/2/22
Test Frequency	2402MHz	Polarization	Horizontal
Temp	20°C	Hum.	62%

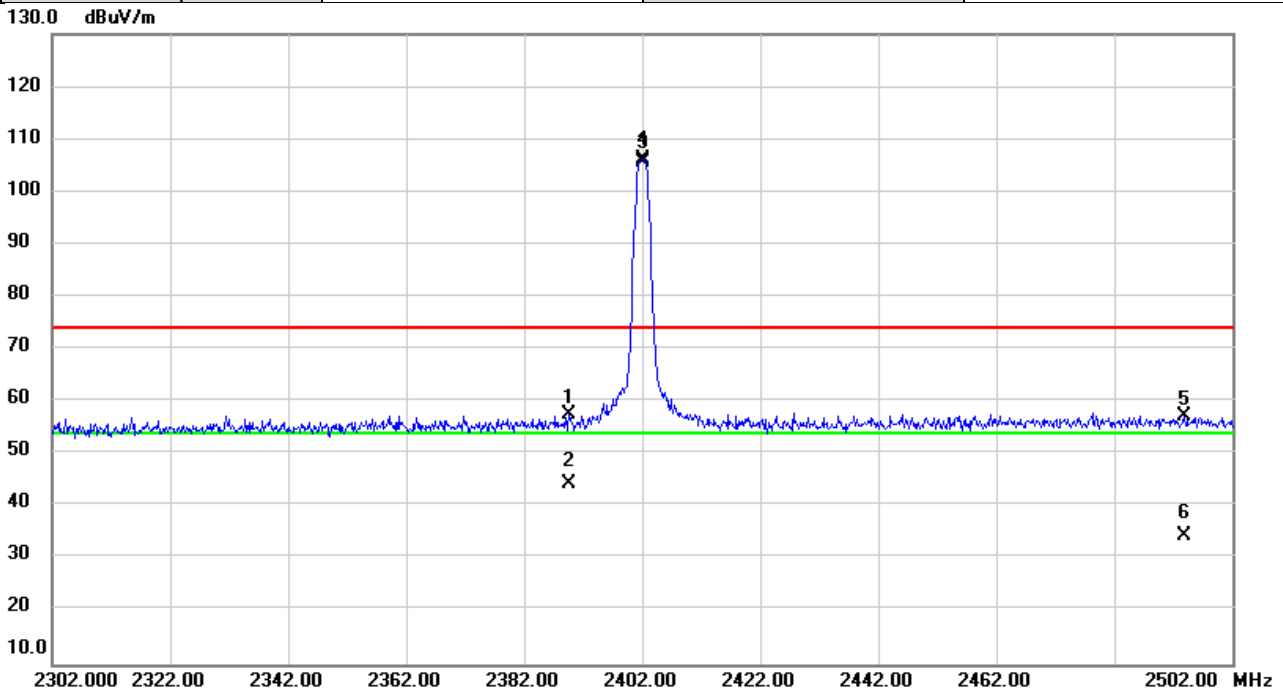

No.	Mk.	Freq.	Reading Level	Correct Factor	Measurement	Limit	Over	Detector	Comment
		MHz	dBuV	dB	dBuV/m	dBuV/m	dB		
1		2389.680	26.45	31.21	57.66	74.00	-16.34	peak	
2		2389.680	13.03	31.21	44.24	54.00	-9.76	AVG	
3	X	2402.000	74.95	31.26	106.21	74.00	32.21	peak	NoLimit
4	*	2402.000	74.30	31.26	105.56	54.00	51.56	AVG	NoLimit
5		2493.880	25.74	31.55	57.29	74.00	-16.71	peak	
6		2493.880	2.94	31.55	34.49	54.00	-19.51	AVG	

REMARKS:

- (1) Measurement Value = Reading Level + Correct Factor.
- (2) Margin Level = Measurement Value - Limit Value.

Test Mode	BLE 5.0 (1 Mbps)	Test Date	2022/2/22
Test Frequency	2480MHz	Polarization	Horizontal
Temp	20°C	Hum.	62%

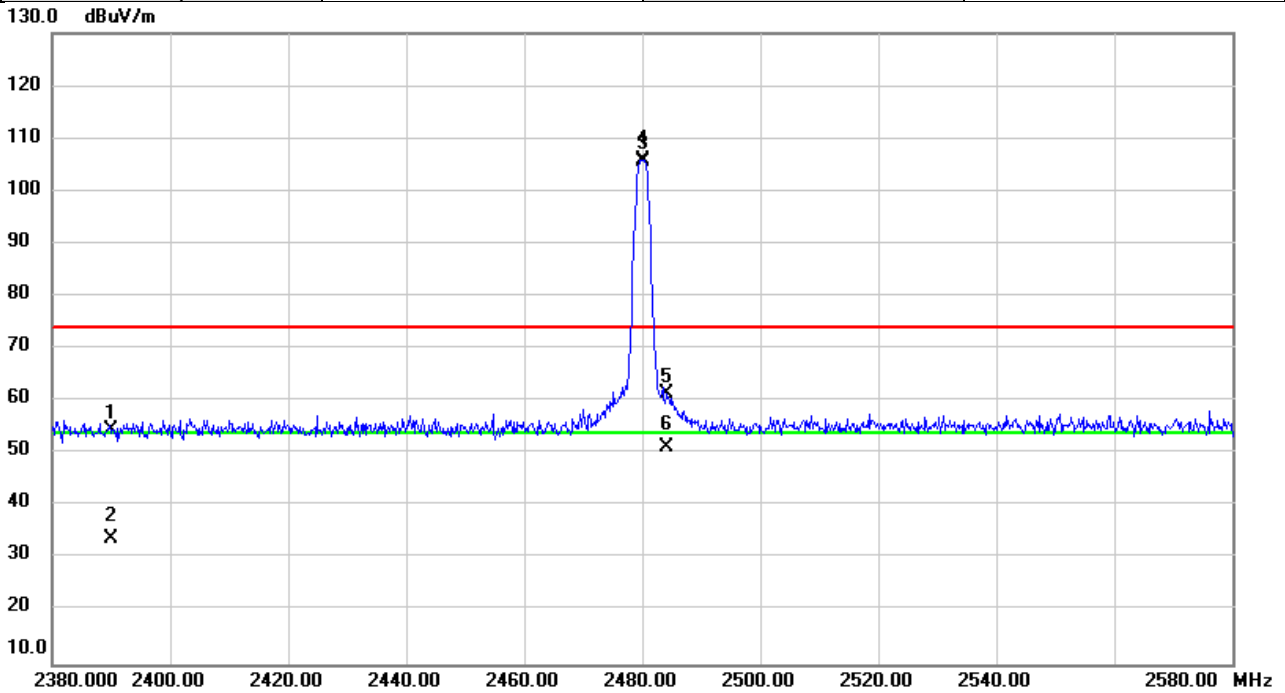

No.	Mk.	Freq.	Reading Level	Correct Factor	Measurement	Limit	Over	Detector	Comment
		MHz	dBuV	dB	dBuV/m	dBuV/m	dB		
1		2390.000	23.41	31.21	54.62	74.00	-19.38	peak	
2		2390.000	2.57	31.21	33.78	54.00	-20.22	AVG	
3	X	2480.000	74.45	31.51	105.96	74.00	31.96	peak	NoLimit
4	*	2480.000	73.96	31.51	105.47	54.00	51.47	AVG	NoLimit
5		2484.207	29.90	31.52	61.42	74.00	-12.58	peak	
6		2484.207	19.74	31.52	51.26	54.00	-2.74	AVG	

**REMARKS:**

- (1) Measurement Value = Reading Level + Correct Factor.
- (2) Margin Level = Measurement Value - Limit Value.

Test Mode	BLE 5.0 (2 Mbps)	Test Date	2022/2/22
Test Frequency	2402MHz	Polarization	Horizontal
Temp	20°C	Hum.	62%

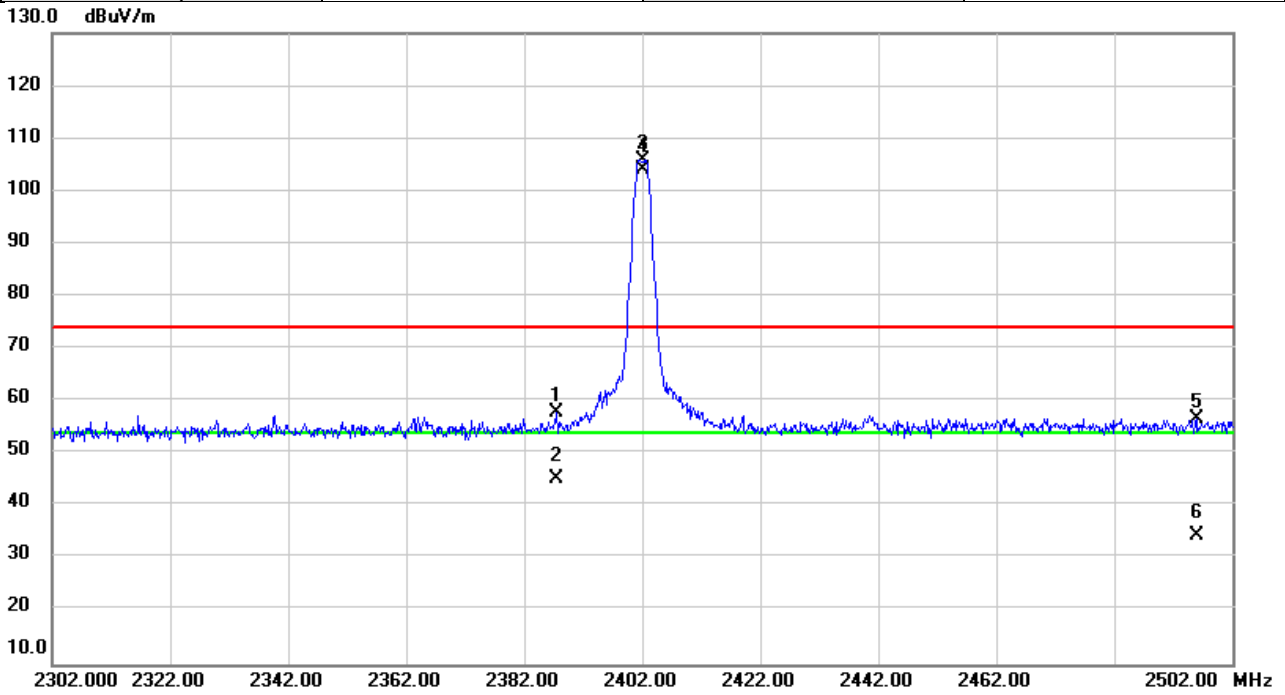

No.	Mk.	Freq.	Reading Level	Correct Factor	Measurement	Limit	Over	Detector	Comment
		MHz	dBuV	dB	dBuV/m	dBuV/m	dB		
1		2387.407	26.55	31.21	57.76	74.00	-16.24	peak	
2		2387.407	13.89	31.21	45.10	54.00	-8.90	AVG	
3	X	2402.000	74.63	31.26	105.89	74.00	31.89	peak	NoLimit
4	*	2402.000	72.83	31.26	104.09	54.00	50.09	AVG	NoLimit
5		2495.873	25.08	31.56	56.64	74.00	-17.36	peak	
6		2495.873	2.88	31.56	34.44	54.00	-19.56	AVG	

**REMARKS:**

- (1) Measurement Value = Reading Level + Correct Factor.
- (2) Margin Level = Measurement Value - Limit Value.

Test Mode	BLE 5.0 (2 Mbps)	Test Date	2022/2/22
Test Frequency	2480MHz	Polarization	Horizontal
Temp	20°C	Hum.	62%

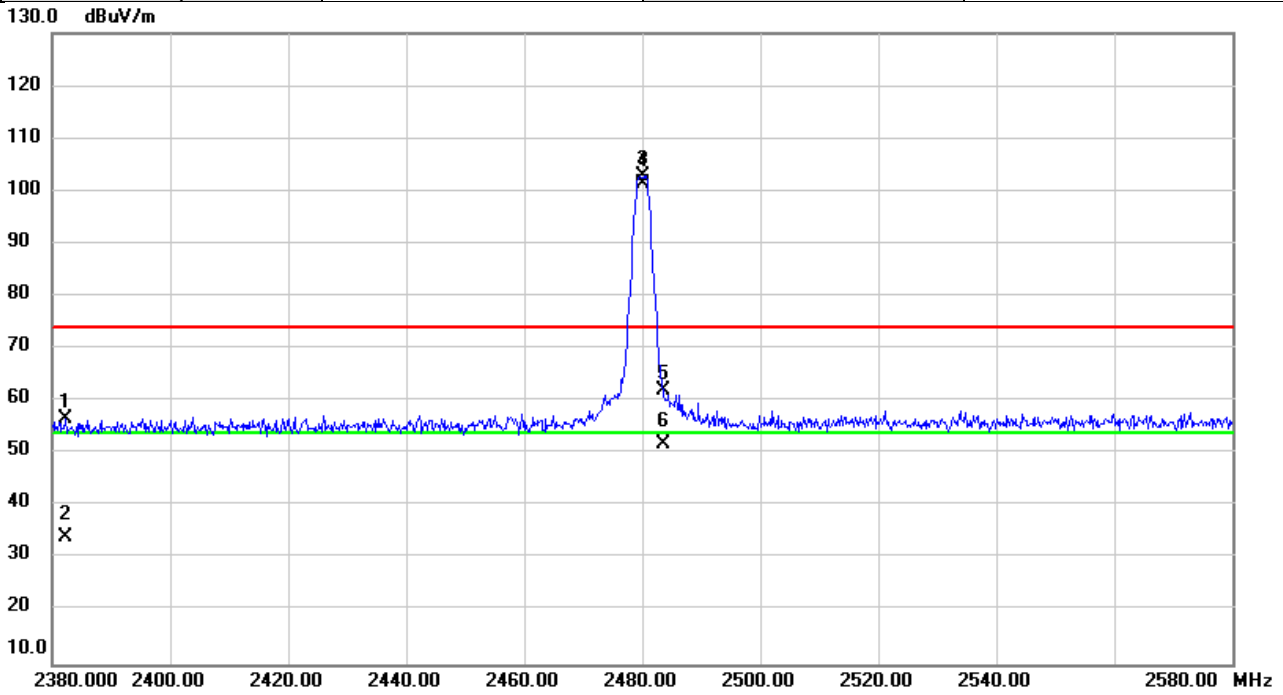

No.	Mk.	Freq.	Reading Level	Correct Factor	Measurement	Limit	Over	Detector	Comment
		MHz	dBuV	dB	dBuV/m	dBuV/m	dB		
1		2382.207	25.48	31.18	56.66	74.00	-17.34	peak	
2		2382.207	2.98	31.18	34.16	54.00	-19.84	AVG	
3	X	2480.000	71.27	31.51	102.78	74.00	28.78	peak	NoLimit
4	*	2480.000	69.74	31.51	101.25	54.00	47.25	AVG	NoLimit
5		2483.500	30.61	31.52	62.13	74.00	-11.87	peak	
6		2483.500	20.25	31.52	51.77	54.00	-2.23	AVG	

**REMARKS:**

- (1) Measurement Value = Reading Level + Correct Factor.
- (2) Margin Level = Measurement Value - Limit Value.

Test Mode	BLE 5.0 (1 Mbps)	Test Date	2022/2/22
Test Frequency	2402MHz	Polarization	Vertical
Temp	20°C	Hum.	62%

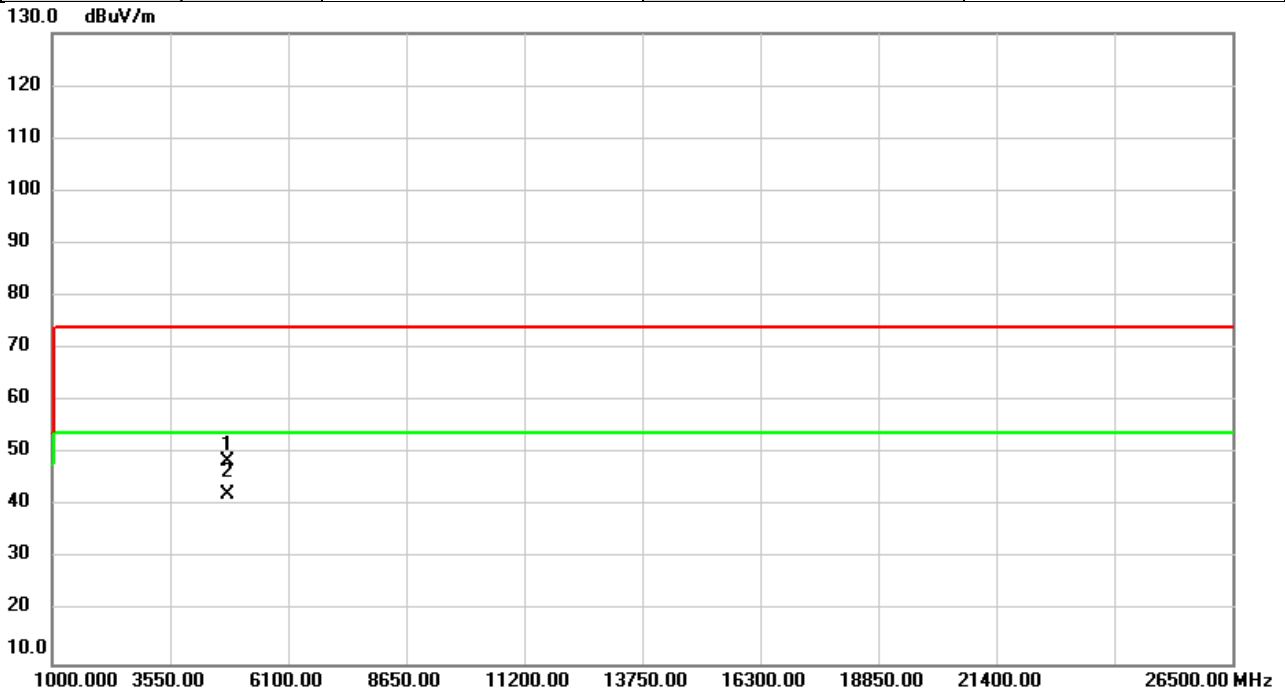

No.	Mk.	Freq. MHz	Reading Level dBuV	Correct Factor dB	Measure- ment dBuV/m	Limit dBuV/m	Over dB	Detector	Comment
1		4804.000	58.51	-9.84	48.67	74.00	-25.33	peak	
2	*	4804.000	52.13	-9.84	42.29	54.00	-11.71	AVG	

**REMARKS:**

- (1) Measurement Value = Reading Level + Correct Factor.
- (2) Margin Level = Measurement Value - Limit Value.

Test Mode	BLE 5.0 (1 Mbps)	Test Date	2022/2/22
Test Frequency	2402MHz	Polarization	Horizontal
Temp	20°C	Hum.	62%

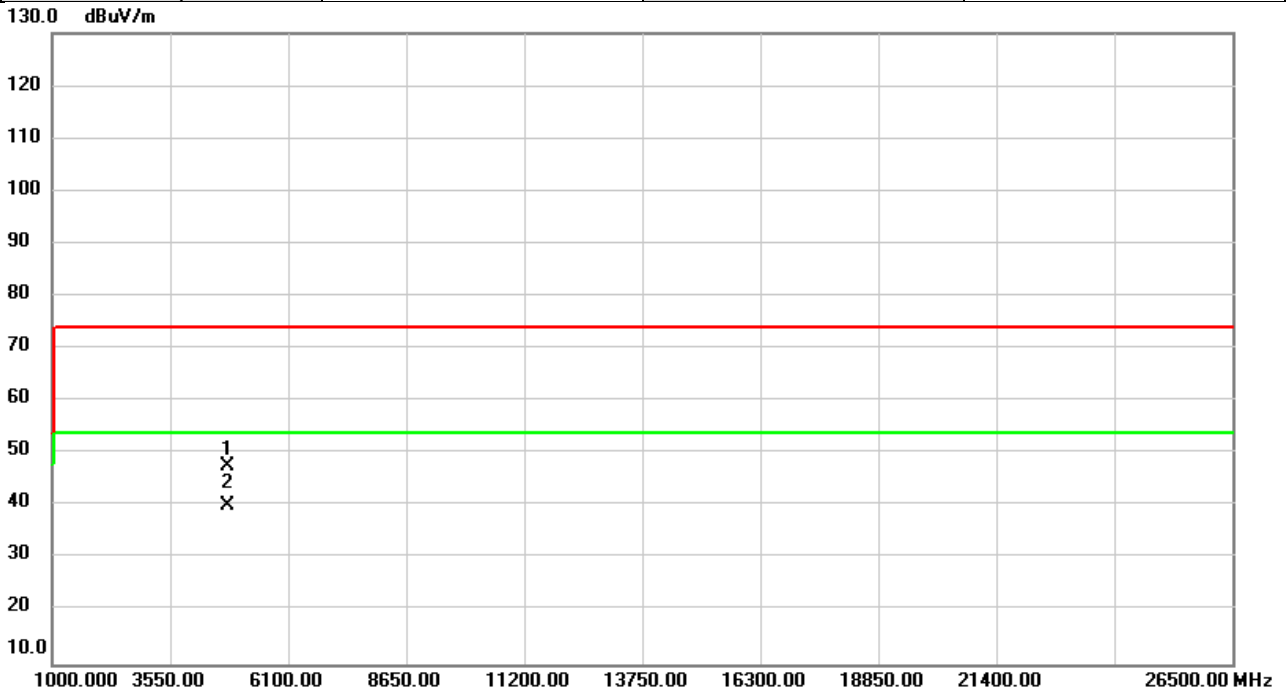

No.	Mk.	Freq. MHz	Reading Level dBuV	Correct Factor dB	Measure- ment dBuV/m	Limit dBuV/m	Over dB	Detector	Comment
1		4804.000	57.37	-9.84	47.53	74.00	-26.47	peak	
2	*	4804.000	50.11	-9.84	40.27	54.00	-13.73	AVG	

REMARKS:

- (1) Measurement Value = Reading Level + Correct Factor.
- (2) Margin Level = Measurement Value - Limit Value.

Test Mode	BLE 5.0 (1 Mbps)	Test Date	2022/2/22
Test Frequency	2440MHz	Polarization	Vertical
Temp	20°C	Hum.	62%

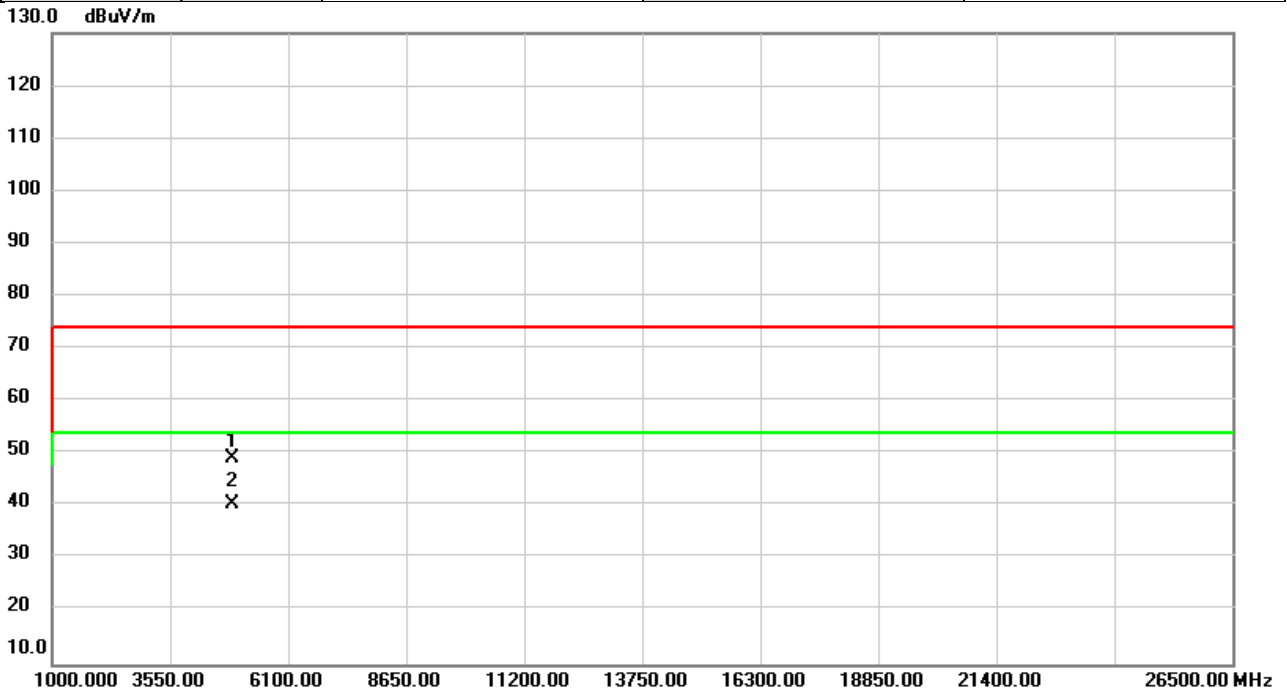

No.	Mk.	Freq. MHz	Reading Level dBuV	Correct Factor dB	Measure- ment dBuV/m	Limit dBuV/m	Over dB	Detector	Comment
1		4880.000	58.98	-9.77	49.21	74.00	-24.79	peak	
2	*	4880.000	50.16	-9.77	40.39	54.00	-13.61	AVG	

**REMARKS:**

- (1) Measurement Value = Reading Level + Correct Factor.
- (2) Margin Level = Measurement Value - Limit Value.



Test Mode	BLE 5.0 (1 Mbps)	Test Date	2022/2/22
Test Frequency	2440MHz	Polarization	Horizontal
Temp	20°C	Hum.	62%

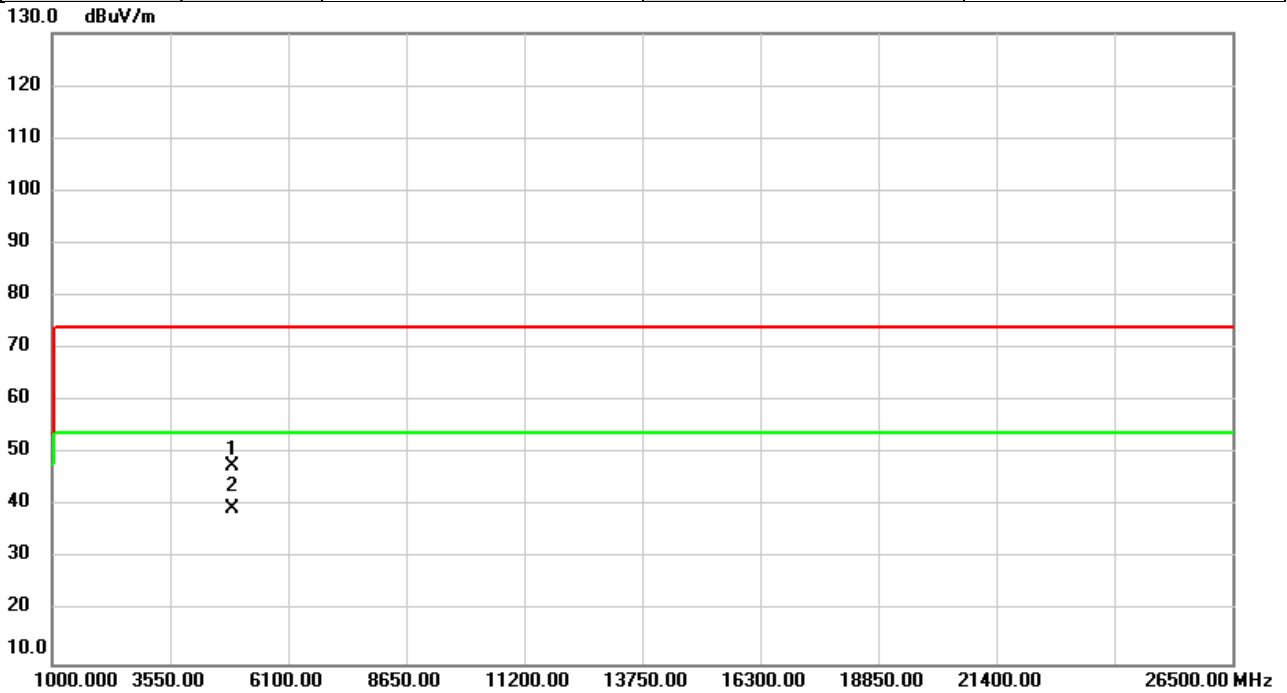

No.	Mk.	Freq. MHz	Reading Level dBuV	Correct Factor dB	Measure- ment dBuV/m	Limit dBuV/m	Over dB	Detector	Comment
1		4880.000	57.32	-9.77	47.55	74.00	-26.45	peak	
2	*	4880.000	49.18	-9.77	39.41	54.00	-14.59	AVG	

**REMARKS:**

- (1) Measurement Value = Reading Level + Correct Factor.
- (2) Margin Level = Measurement Value - Limit Value.

Test Mode	BLE 5.0 (1 Mbps)	Test Date	2022/2/22
Test Frequency	2480MHz	Polarization	Vertical
Temp	20°C	Hum.	62%

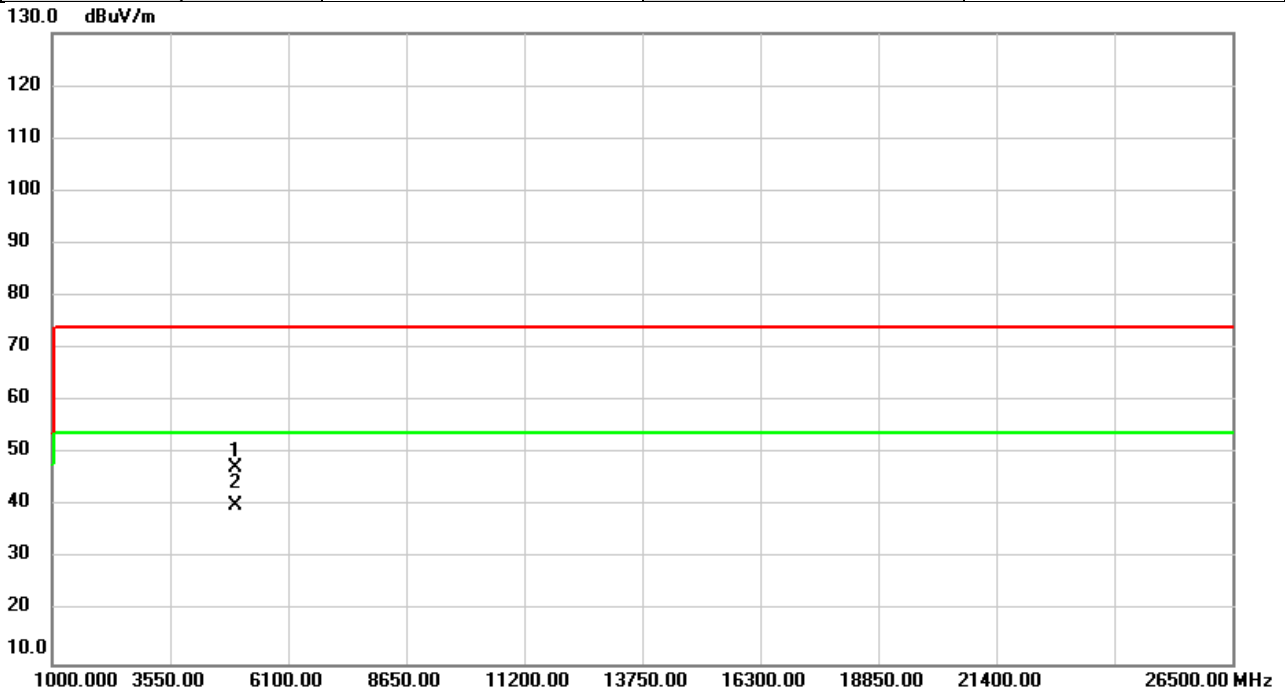

No.	Mk.	Freq. MHz	Reading Level dBuV	Correct Factor dB	Measure- ment dBuV/m	Limit dBuV/m	Over dB	Detector	Comment
1		4960.000	57.16	-9.68	47.48	74.00	-26.52	peak	
2	*	4960.000	49.98	-9.68	40.30	54.00	-13.70	AVG	

**REMARKS:**

- (1) Measurement Value = Reading Level + Correct Factor.
- (2) Margin Level = Measurement Value - Limit Value.

Test Mode	BLE 5.0 (1 Mbps)	Test Date	2022/2/22
Test Frequency	2480MHz	Polarization	Horizontal
Temp	20°C	Hum.	62%

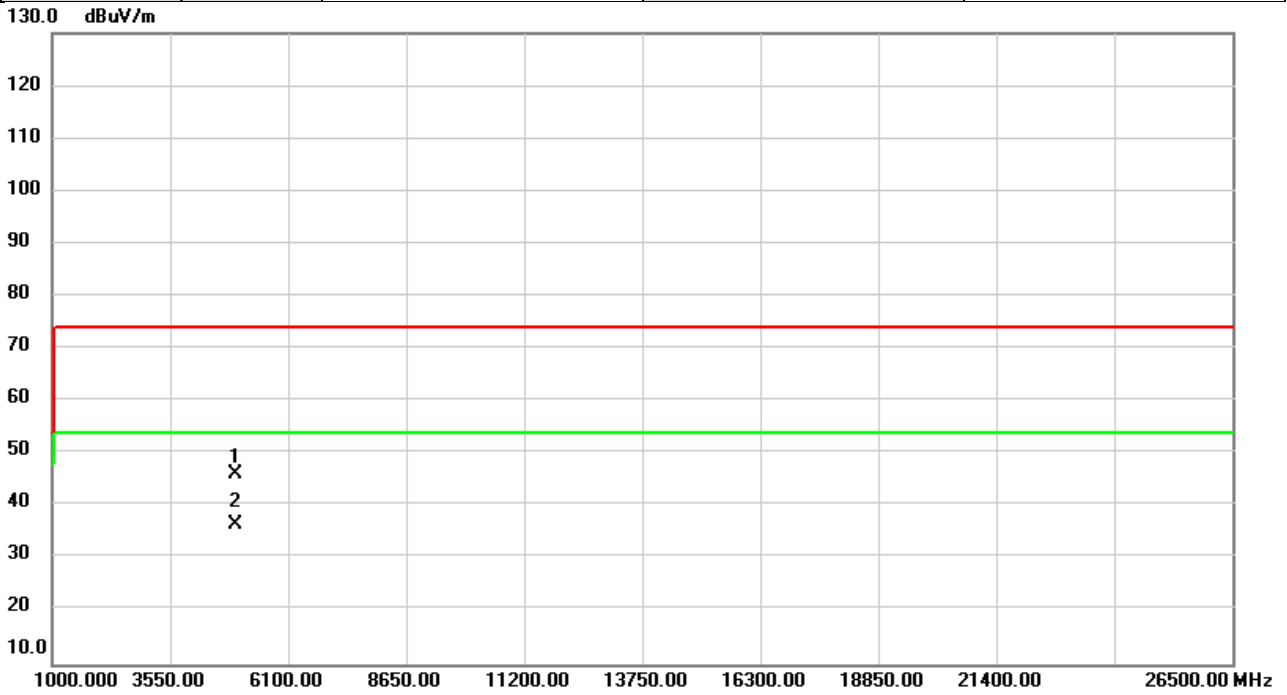

No.	Mk.	Freq. MHz	Reading Level dBuV	Correct Factor dB	Measure- ment dBuV/m	Limit dBuV/m	Over dB	Detector	Comment
1		4960.000	55.84	-9.68	46.16	74.00	-27.84	peak	
2	*	4960.000	46.16	-9.68	36.48	54.00	-17.52	AVG	

**REMARKS:**

- (1) Measurement Value = Reading Level + Correct Factor.
- (2) Margin Level = Measurement Value - Limit Value.

Test Mode	BLE 5.0 (2 Mbps)	Test Date	2022/2/22
Test Frequency	2402MHz	Polarization	Vertical
Temp	20°C	Hum.	62%

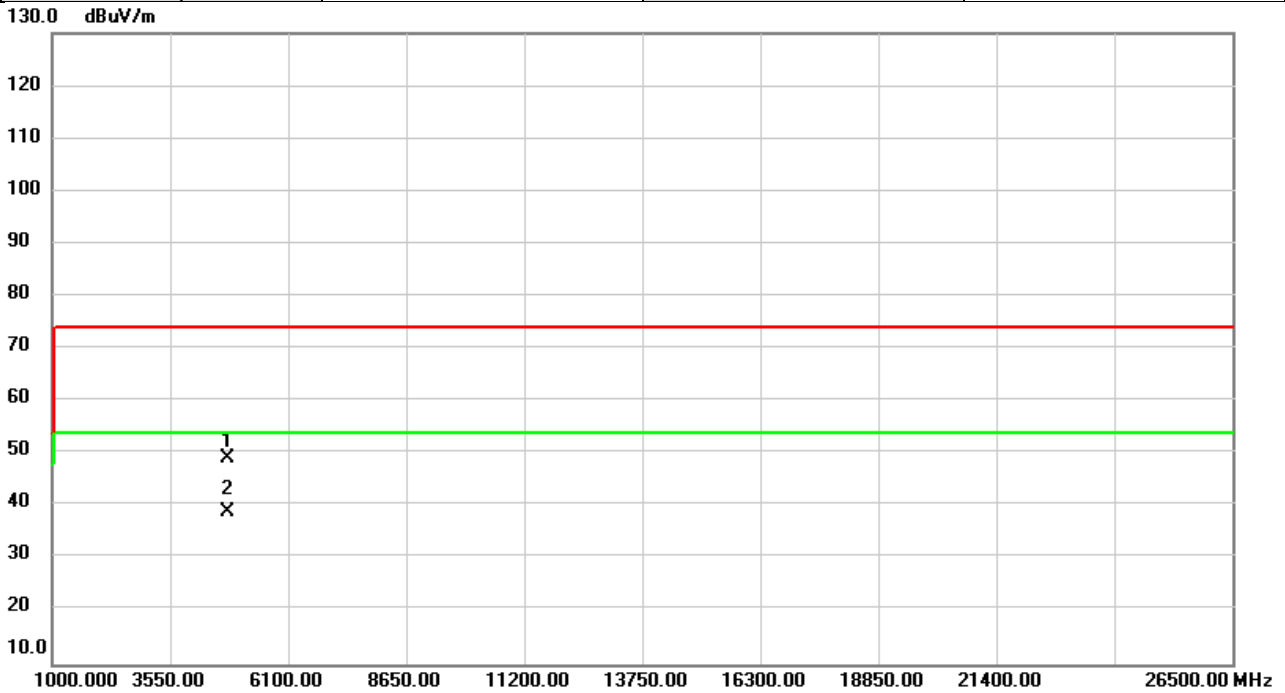

No.	Mk.	Freq. MHz	Reading Level dBuV	Correct Factor dB	Measure- ment dBuV/m	Limit dBuV/m	Over dB	Detector	Comment
1		4804.000	58.99	-9.84	49.15	74.00	-24.85	peak	
2	*	4804.000	48.84	-9.84	39.00	54.00	-15.00	AVG	

**REMARKS:**

- (1) Measurement Value = Reading Level + Correct Factor.
- (2) Margin Level = Measurement Value - Limit Value.

Test Mode	BLE 5.0 (2 Mbps)	Test Date	2022/2/22
Test Frequency	2402MHz	Polarization	Horizontal
Temp	20°C	Hum.	62%

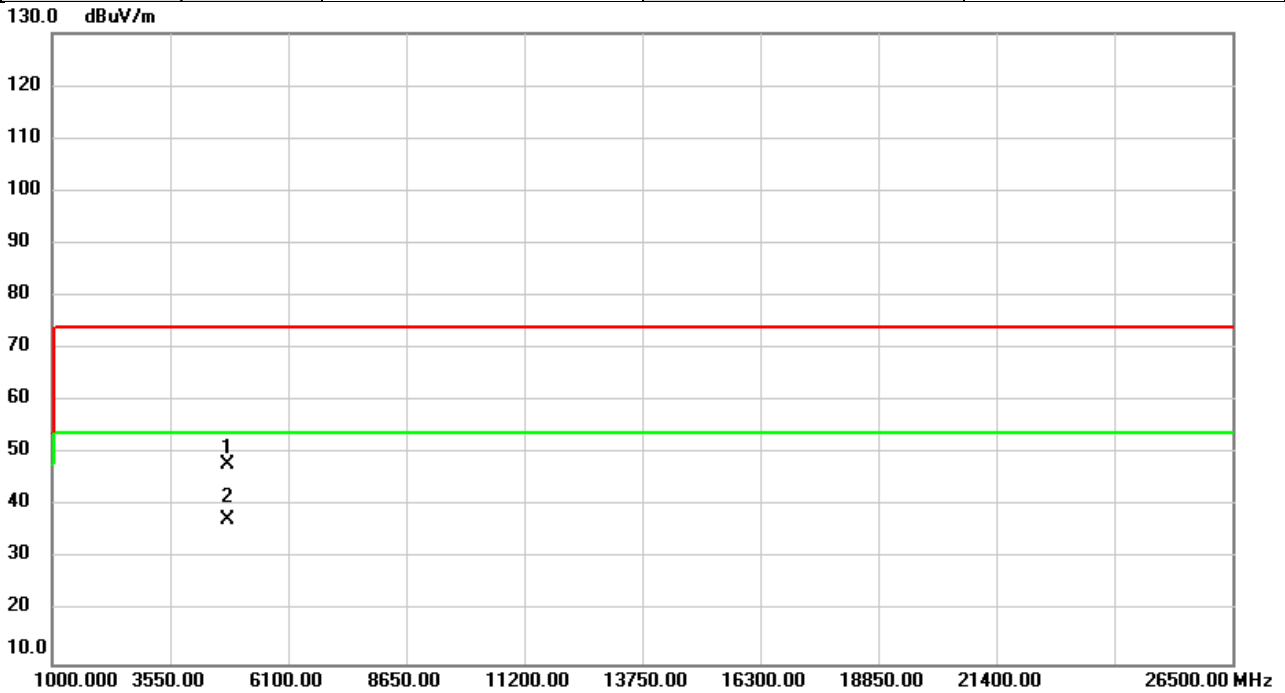

No.	Mk.	Freq. MHz	Reading Level dBuV	Correct Factor dB	Measure- ment dBuV/m	Limit dBuV/m	Over dB	Detector	Comment
1		4804.000	57.69	-9.84	47.85	74.00	-26.15	peak	
2	*	4804.000	47.21	-9.84	37.37	54.00	-16.63	AVG	

REMARKS:

- (1) Measurement Value = Reading Level + Correct Factor.
- (2) Margin Level = Measurement Value - Limit Value.

Test Mode	BLE 5.0 (2 Mbps)	Test Date	2022/2/22
Test Frequency	2440MHz	Polarization	Vertical
Temp	20°C	Hum.	62%

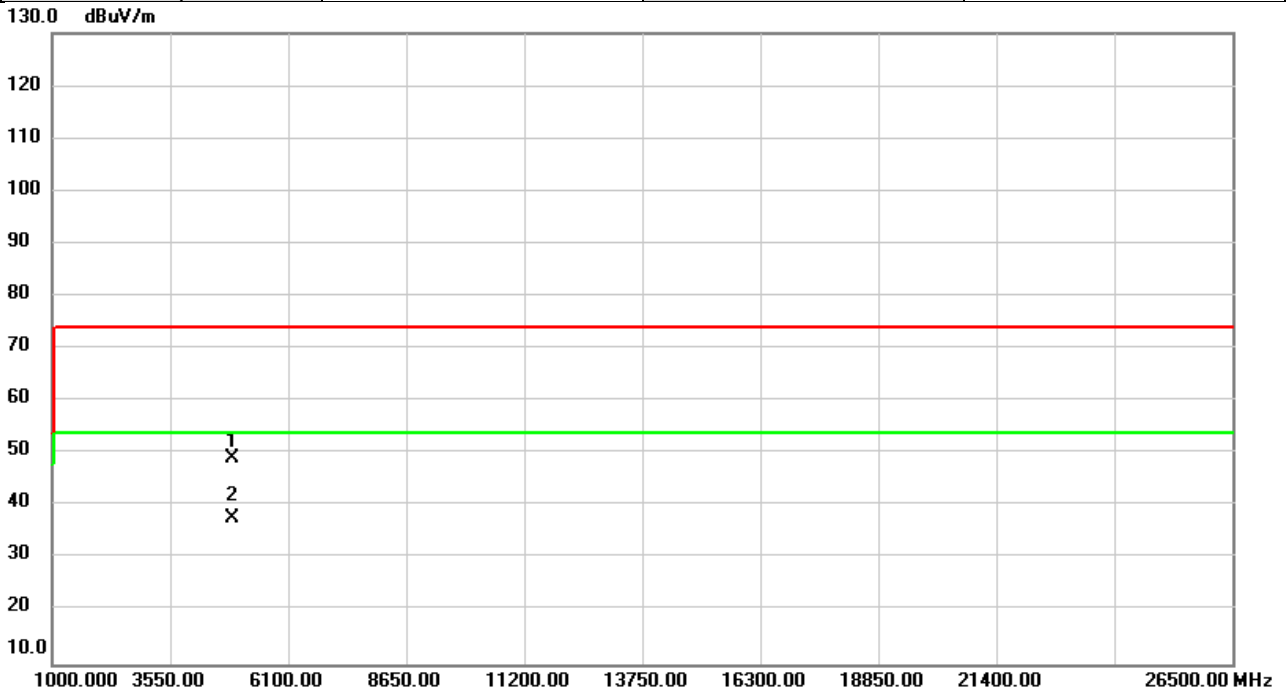

No.	Mk.	Freq. MHz	Reading Level dBuV	Correct Factor dB	Measure- ment dBuV/m	Limit dBuV/m	Over dB	Detector	Comment
1		4880.000	58.94	-9.77	49.17	74.00	-24.83	peak	
2	*	4880.000	47.57	-9.77	37.80	54.00	-16.20	AVG	

**REMARKS:**

- (1) Measurement Value = Reading Level + Correct Factor.
- (2) Margin Level = Measurement Value - Limit Value.

Test Mode	BLE 5.0 (2 Mbps)	Test Date	2022/2/22
Test Frequency	2440MHz	Polarization	Horizontal
Temp	20°C	Hum.	62%

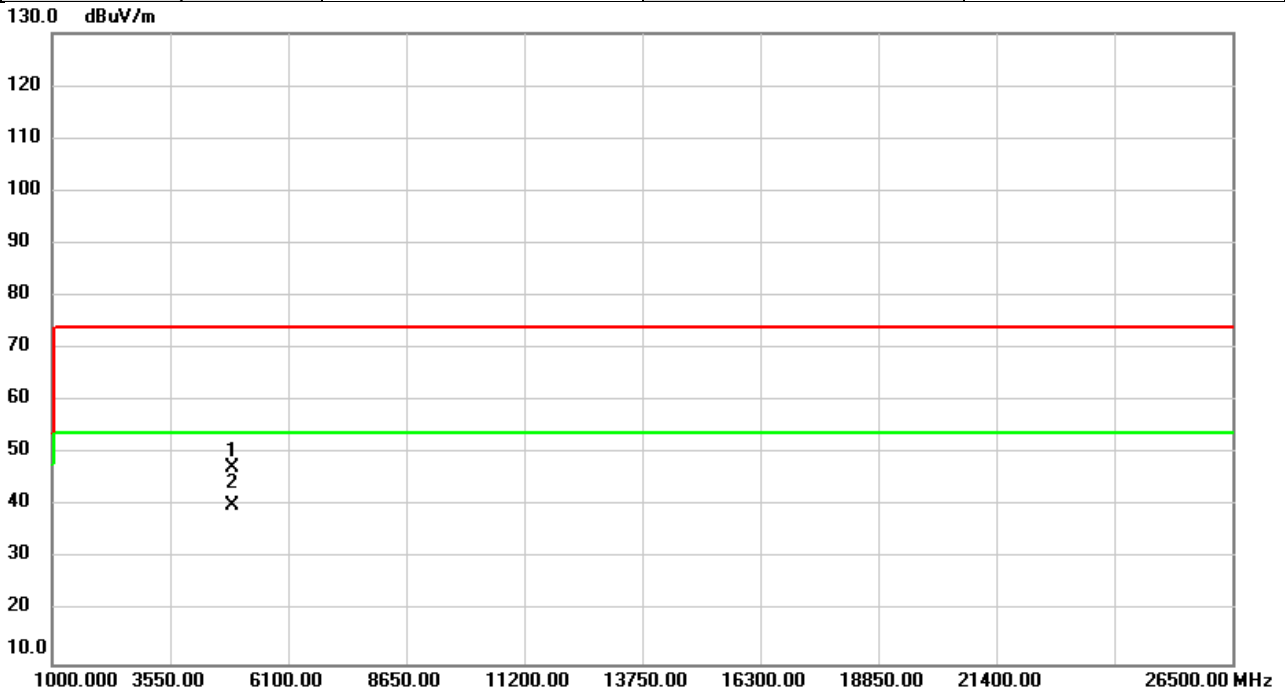

No.	Mk.	Freq. MHz	Reading Level dBuV	Correct Factor dB	Measure- ment dBuV/m	Limit dBuV/m	Over dB	Detector	Comment
1		4880.000	57.12	-9.77	47.35	74.00	-26.65	peak	
2	*	4880.000	49.87	-9.77	40.10	54.00	-13.90	AVG	

**REMARKS:**

- (1) Measurement Value = Reading Level + Correct Factor.
- (2) Margin Level = Measurement Value - Limit Value.

Test Mode	BLE 5.0 (2 Mbps)	Test Date	2022/2/22
Test Frequency	2480MHz	Polarization	Vertical
Temp	20°C	Hum.	62%

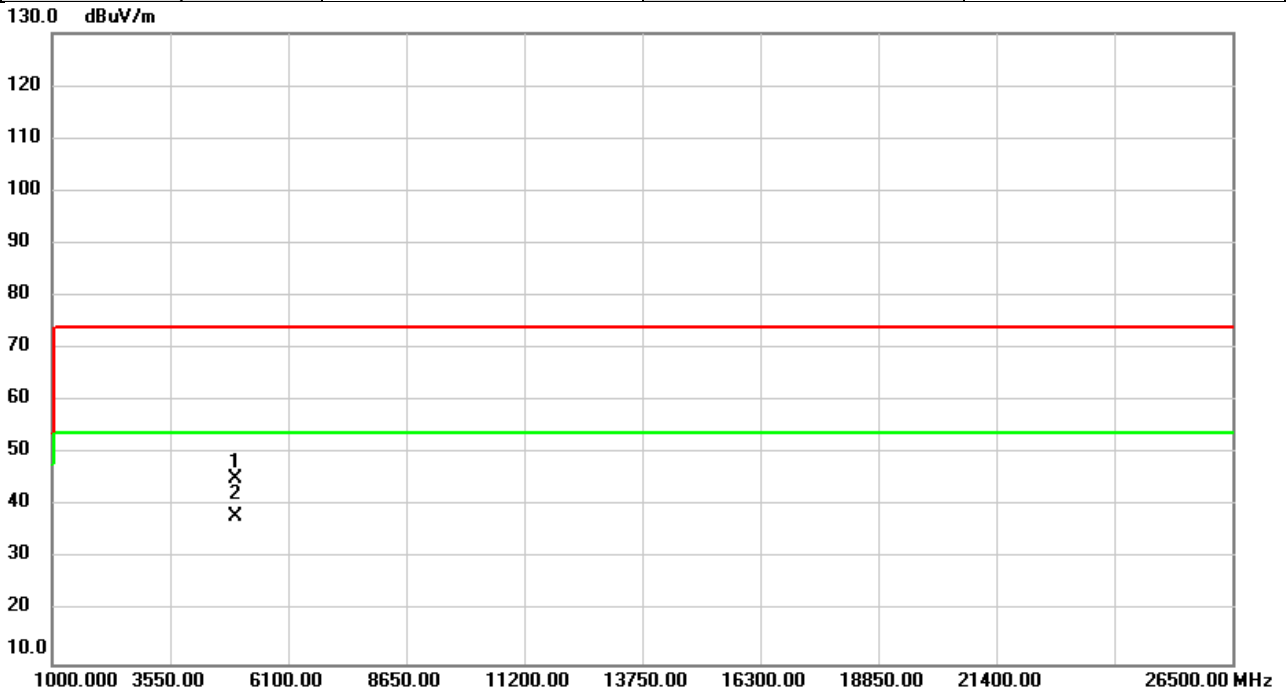

No.	Mk.	Freq. MHz	Reading Level dBuV	Correct Factor dB	Measure- ment dBuV/m	Limit dBuV/m	Over dB	Detector	Comment
1		4960.000	54.90	-9.68	45.22	74.00	-28.78	peak	
2	*	4960.000	47.80	-9.68	38.12	54.00	-15.88	AVG	

**REMARKS:**

- (1) Measurement Value = Reading Level + Correct Factor.
- (2) Margin Level = Measurement Value - Limit Value.



Test Mode	BLE 5.0 (2 Mbps)	Test Date	2022/2/22
Test Frequency	2480MHz	Polarization	Horizontal
Temp	20°C	Hum.	62%

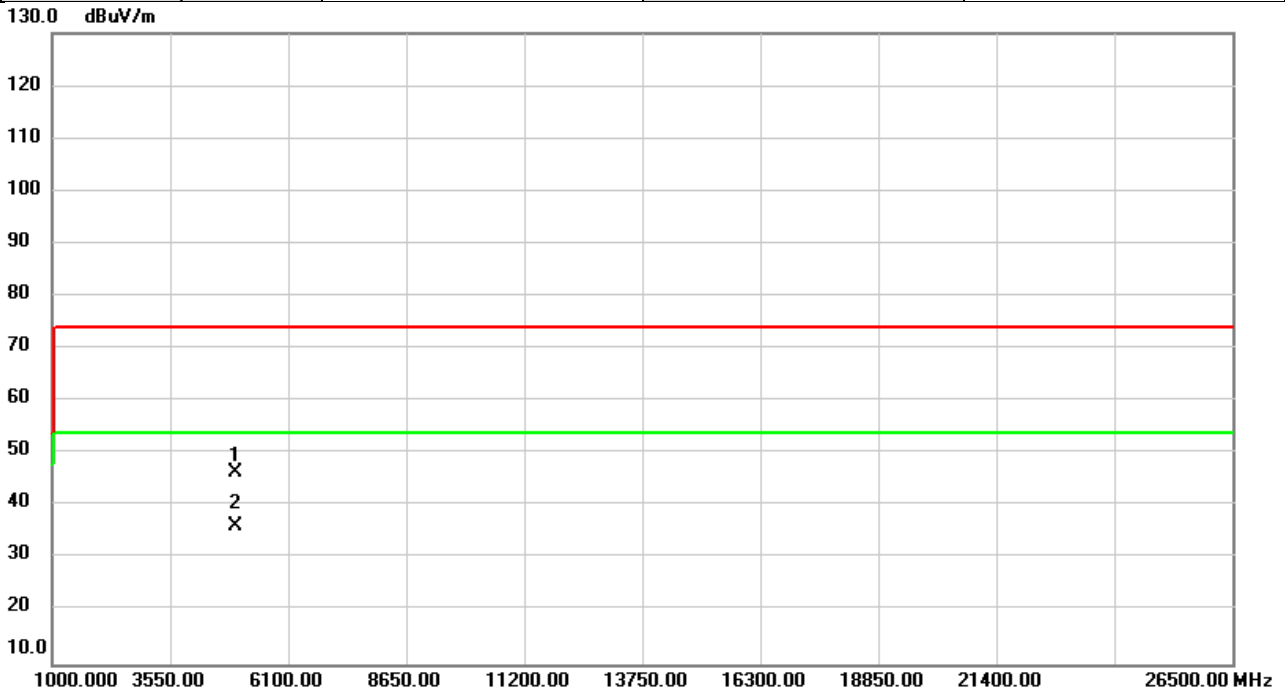

No.	Mk.	Freq. MHz	Reading Level dBuV	Correct Factor dB	Measure- ment dBuV/m	Limit dBuV/m	Over dB	Detector	Comment
1		4960.000	56.01	-9.68	46.33	74.00	-27.67	peak	
2	*	4960.000	45.80	-9.68	36.12	54.00	-17.88	AVG	

**REMARKS:**

- (1) Measurement Value = Reading Level + Correct Factor.
- (2) Margin Level = Measurement Value - Limit Value.

## APPENDIX C BANDWIDTH

Test Mode:	1Mbps
------------	-------

Frequency (MHz)	6dB Bandwidth (MHz)	99% Occupied BW (MHz)	Min. Limit (kHz)	Test Result
2402	0.74	1.08	500	Pass
2440	0.76	1.08	500	Pass
2480	0.76	1.08	500	Pass

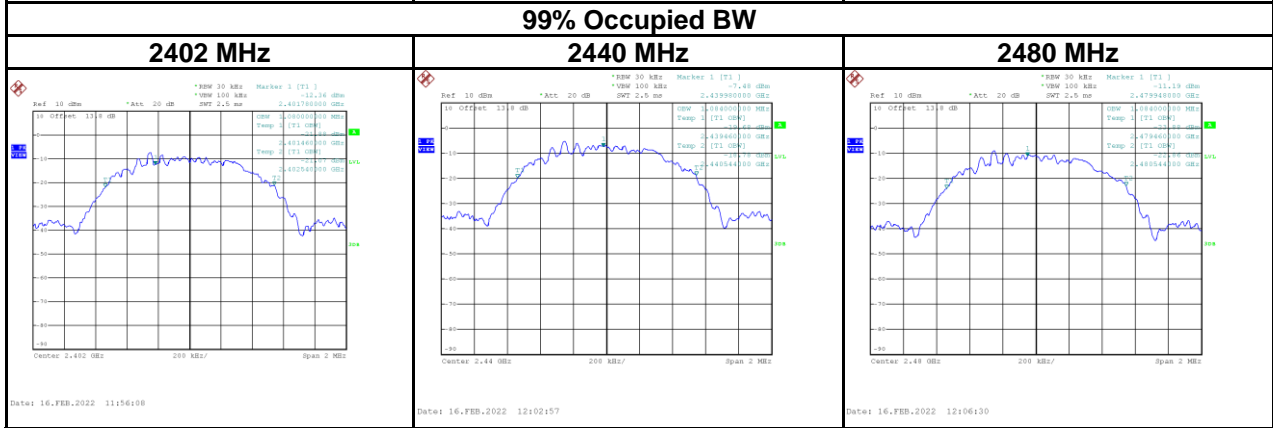
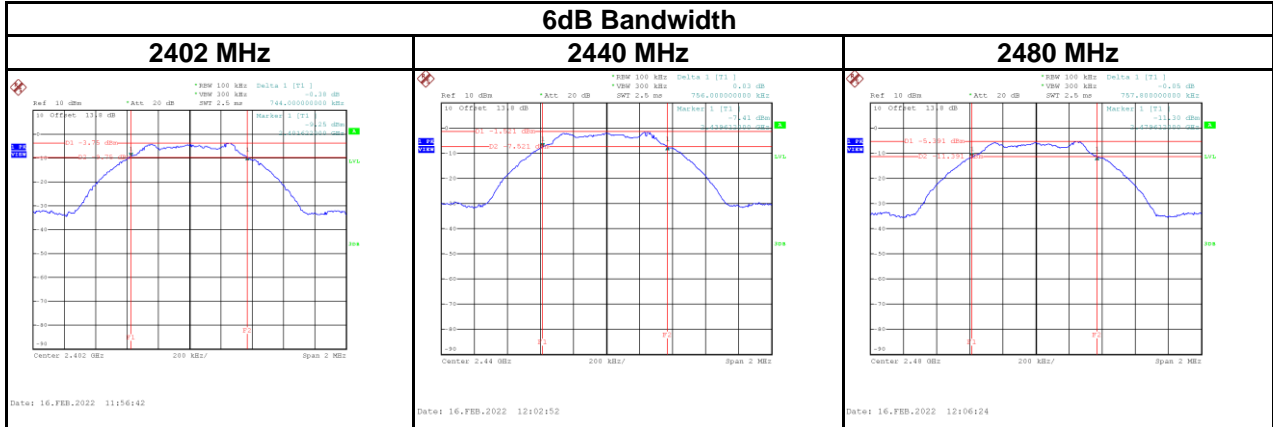

Test Mode:	2Mbps
------------	-------

Frequency (MHz)	6dB Bandwidth (MHz)	99% Occupied BW (MHz)	Min. Limit (kHz)	Test Result
2402	1.41	2.13	500	Pass
2440	1.42	2.13	500	Pass
2480	1.40	2.14	500	Pass

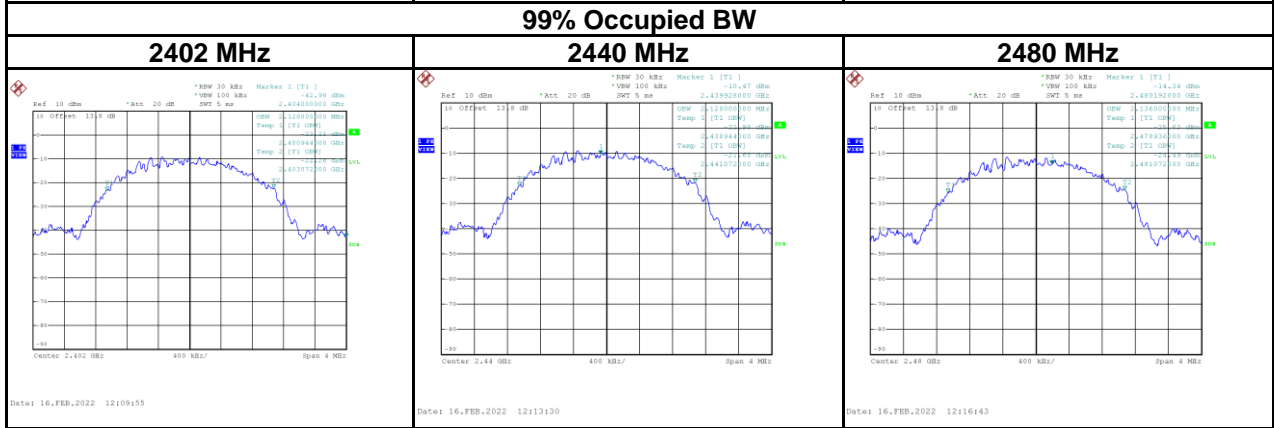
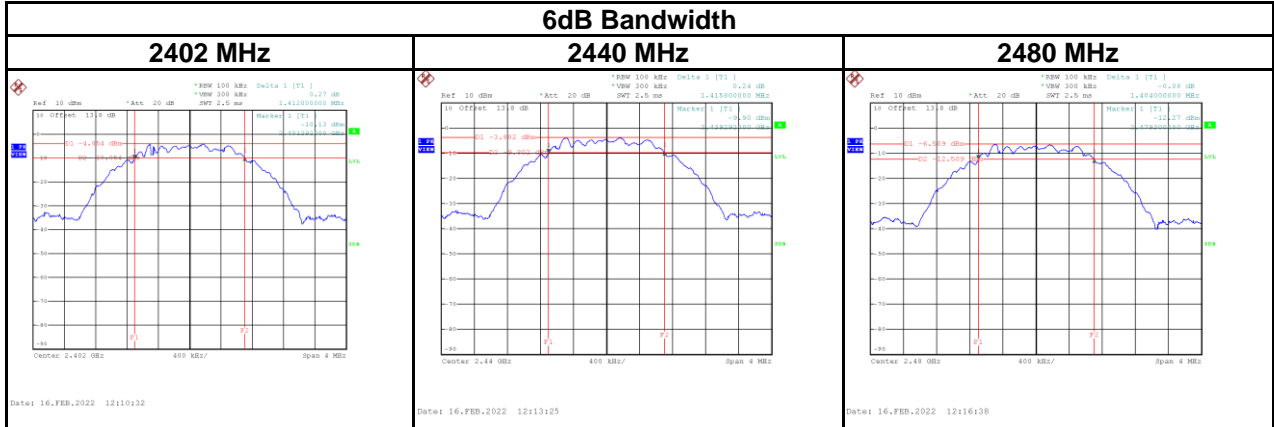

## APPENDIX D OUTPUT POWER

Test Mode :	1Mbps	Tested Date	2022/2/16
-------------	-------	-------------	-----------

Frequency (MHz)	Conducted Power (dBm)	Conducted Power (W)	Max. Limit (dBm)	Max. Limit (W)	Test Result
2402	10.05	0.0101	30.00	1.0000	Pass
2440	10.07	0.0102	30.00	1.0000	Pass
2480	10.10	0.0102	30.00	1.0000	Pass

Test Mode :	2Mbps	Tested Date	2022/2/16
-------------	-------	-------------	-----------

Frequency (MHz)	Conducted Power (dBm)	Conducted Power (W)	Max. Limit (dBm)	Max. Limit (W)	Test Result
2402	10.07	0.0102	30.00	1.0000	Pass
2440	10.04	0.0101	30.00	1.0000	Pass
2480	6.59	0.0046	30.00	1.0000	Pass

## **APPENDIX E POWER SPECTRAL DENSITY TEST**

Test Mode : 1Mbps

Frequency (MHz)	Power Density (dBm/3kHz)	Max. Limit (dBm/3kHz)	Test Result
2402	-8.49	8	Pass
2440	-8.74	8	Pass
2480	-8.46	8	Pass

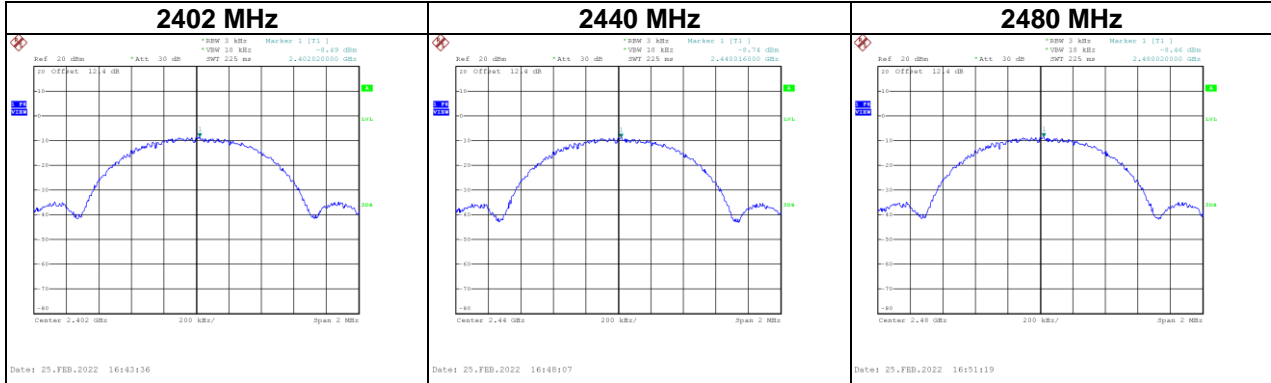

Test Mode : 2Mbps

Frequency (MHz)	Power Density (dBm/3kHz)	Max. Limit (dBm/3kHz)	Test Result
2402	-10.75	8	Pass
2440	-11.05	8	Pass
2480	-14.24	8	Pass

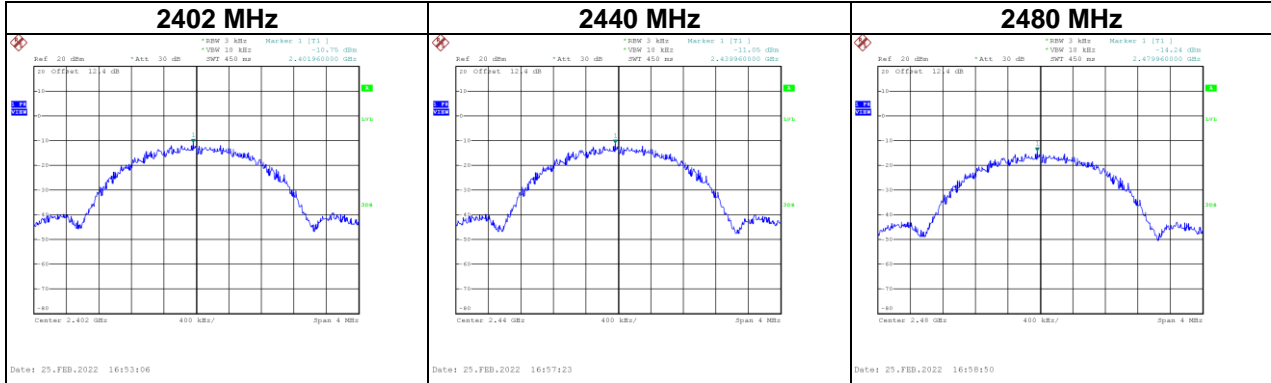



## **APPENDIX F ANTENNA CONDUCTED SPURIOUS EMISSION**

Test Mode : 1Mbps

### Low Bandedge-2402 MHz

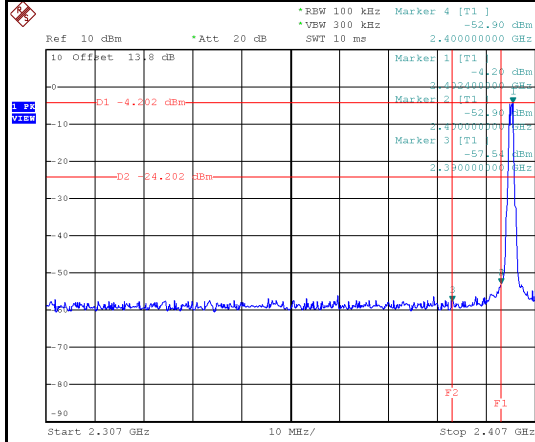

Date: 16.FEB.2022 11:57:05

### High Bandedge-2480 MHz

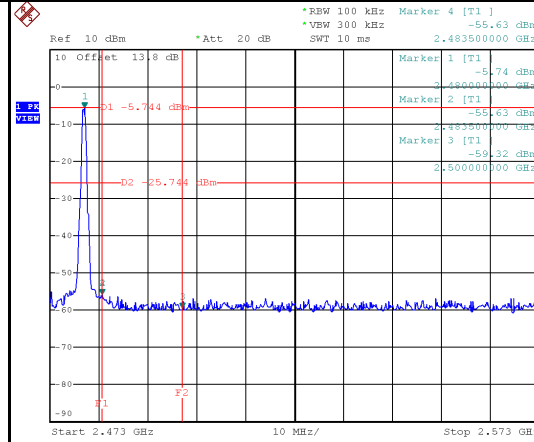

Date: 16.FEB.2022 12:06:37

### 2402 MHz – 10th Harmonics

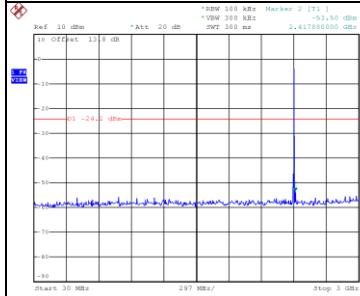

Date: 16.FEB.2022 11:57:10

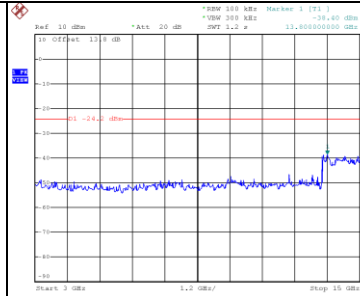

Date: 16.FEB.2022 11:57:25

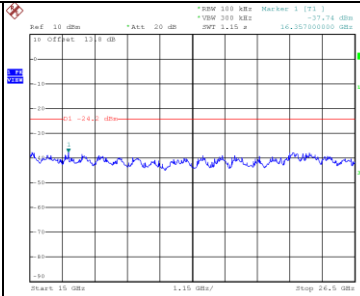

Date: 16.FEB.2022 11:57:32

### 2440 MHz – 10th Harmonics

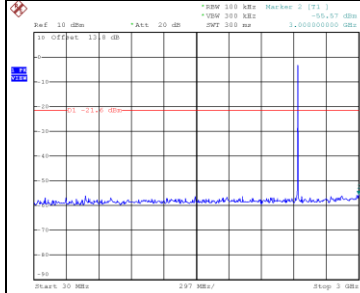

Date: 16.FEB.2022 12:03:17

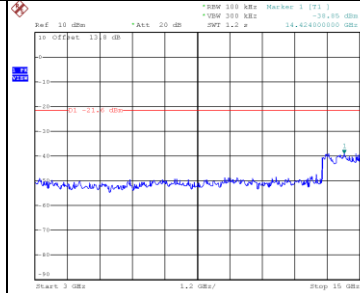

Date: 16.FEB.2022 12:03:24

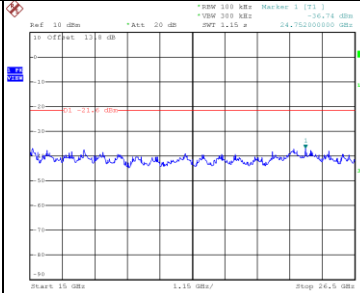

Date: 16.FEB.2022 12:03:31

### 2480 MHz – 10th Harmonics

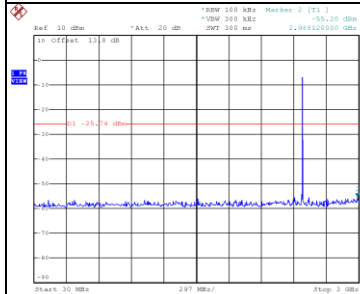

Date: 16.FEB.2022 12:06:50

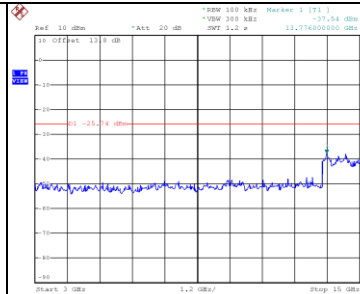

Date: 16.FEB.2022 12:06:57

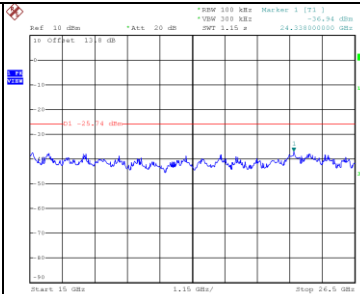

Date: 16.FEB.2022 12:07:03

Test Mode : 2Mbps

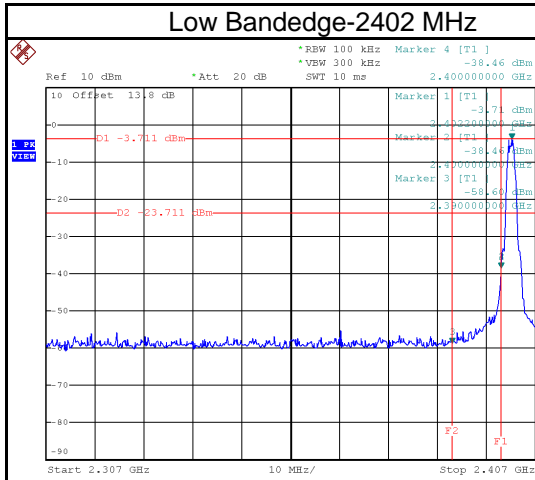

Date: 16.FEB.2022 12:10:55

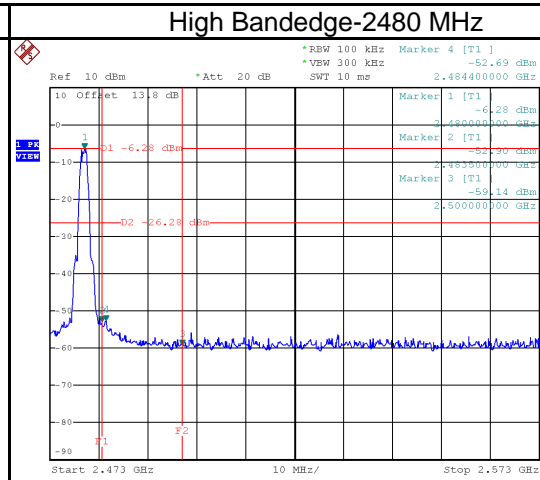

Date: 16.FEB.2022 12:16:50

## 2402 MHz – 10th Harmonics

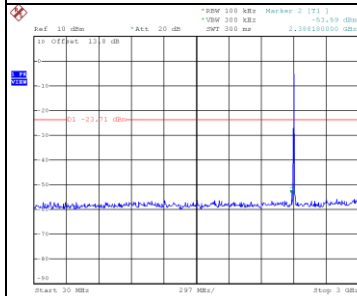

Date: 16.FEB.2022 12:11:08

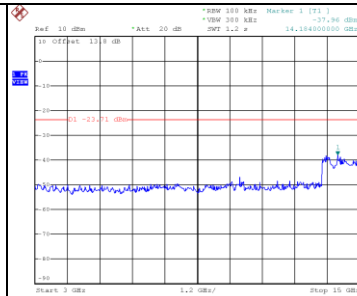

Date: 16.FEB.2022 12:11:15

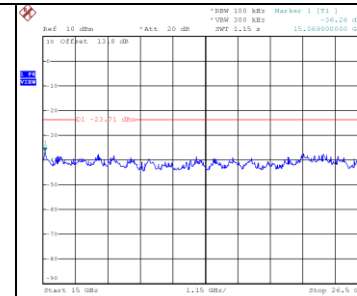

Date: 16.FEB.2022 12:11:22

## 2440 MHz – 10th Harmonics

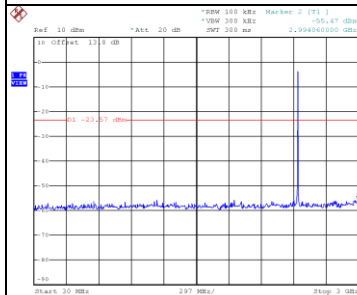

Date: 16.FEB.2022 12:14:06

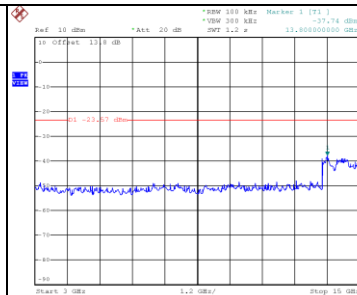

Date: 16.FEB.2022 12:14:13

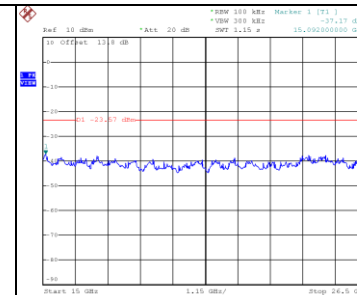

Date: 16.FEB.2022 12:14:20

## 2480 MHz – 10th Harmonics

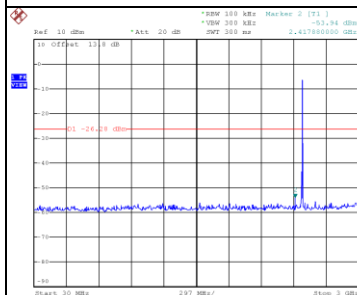

Date: 16.FEB.2022 12:17:03

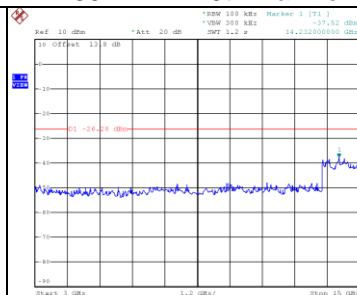

Date: 16.FEB.2022 12:17:10

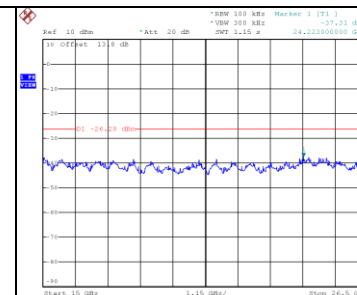

Date: 16.FEB.2022 12:17:17

End of Test Report