

Test Site:
 FCC Test Site No.: 96997
 IC OATS No.: IC3475A-1



ECL-TAL Test Report No.: 09-195

Equipment under test: ION-M4/8 19"
FCC ID: XS5- IONM4819I

Type of test: FCC 47 CFR Part 90 Subpart I
 Private Land Mobile Repeater

Measurement Procedures: ANSI C63.4 (2009)
 ANSI/TIA 603-C-2004

Test result: Passed

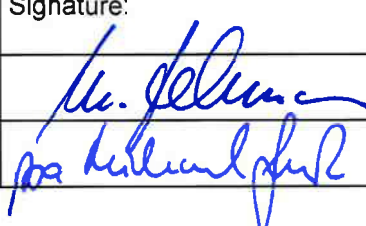
Date of issue:	16.12.09			Signature:
Issue-No.:	04	Author:	M. Lehmann Test engineer	
Date of delivery:	24.11.09	Checked:	M. Grytz Operational manager	
Test dates:	24.11. – 09.12.09			
Pages:	35			



Manufacturer: ANDREW Wireless Systems GmbH
Industriering 10

D-86675 Buchdorf

Tel.: +49 (0)9099 69 0

Fax: +49 (0)9099 69 140

Test Location: HERBERG Service Plus GmbH
European Compliance Laboratory (ECL)

Nordostpark 51

D-90411 Nürnberg

Tel.: +49 0911 59835 923

Fax: +49 0911 59835 90

General:

The purpose of this report is to show compliance to the FCC regulations for unlicensed devices operating under section 15.249 of the Code of Federal Regulations title 47.

This report informs about the results of the EMC tests, it only refers to the equipment under test. No part of this report may be reproduced in any form, without written permission.



Table of contents

1	TEST RESULTS SUMMARY	5
2	EQUIPMENT UNDER TEST (E.U.T.)	6
2.1	DESCRIPTION	6
2.1.1	DOWNLINK	6
2.1.2	UPLINK	6
2.1.3	DESCRIPTION OF EUT	7
2.1.4	SYSTEM DIAGRAMS	7
2.1.5	BLOCK DIAGRAM OF MEASUREMENT REFERENCE POINTS	8
3	TEST SITE BUCHDORF (ANDREW)	9
3.1	TEST ENVIRONMENT	9
3.2	TEST EQUIPMENT	9
3.3	INPUT AND OUTPUT LOSSES	9
4	RF POWER OUT: §90.635, §2.1046	10
4.1	LIMIT.....	10
4.2	TEST METHOD	10
4.3	TEST RESULTS	11
4.3.1	DOWNLINK.....	11
4.3.1.1	Analog.....	12
4.3.1.2	FSK.....	14
4.3.2	UPLINK.....	17
4.4	SUMMARY TEST RESULT.....	17
5	OCCUPIED BANDWIDTH: §90.210, §2.1049	18
5.1	LIMIT.....	18
5.2	TEST METHOD	18
5.3	TEST RESULTS	19
5.3.1	DOWNLINK.....	20
5.3.1.1	Analog.....	20
5.3.1.2	FSK.....	21
5.3.1.3	Analog.....	22
5.3.1.4	FSK.....	23
5.3.1.5	Analog.....	24
5.3.1.6	FSK.....	25
5.3.2	UPLINK.....	26
5.4	SUMMARY TEST RESULT.....	26
6	SPURIOUS EMISSIONS AT ANTENNA TERMINALS: §90.210, §2.1051.....	27
6.1	LIMIT.....	27
6.2	TEST METHOD	27
6.3	TEST RESULTS	28



6.3.1	DOWNLINK	30
6.3.1.1	Analog < 1MHz to band edge	30
6.3.1.2	FSK < 1MHz to band edge	31
6.3.1.3	Analog < 1MHz to band edge	32
6.3.1.4	FSK < 1MHz to band edge	32
6.3.1.5	Analog < 1MHz to band edge	33
6.3.1.6	FSK < 1MHz to band edge	34
6.3.1.7	Analog > 1MHz to band edge	35
6.3.1.8	FSK > 1MHz to band edge	38
6.3.2	UPLINK	41
6.4	SUMMARY TEST RESULT	41
7	RADIATED SPURIOUS EMISSIONS AT THE ECL: §90.210, §2.1053	42
7.1	EMISSION MASK LIMITS	42
7.2	TEST METHOD	42
7.3	TEST RESULTS	43
7.3.1	SPURIOUS EMISSION WITHIN THE BAND 30 MHz TO 9 GHz.	43
7.3.2	TEST DATA	43
8	HISTORY	43



1 Test Results Summary

Name of Test	FCC Para. No.	FCC Method	FCC Spec.	Result
RF Power Output	90.635	2.1046	1000 Watts	Complies
Occupied Bandwidth	90.210	2.1049	Input/Output	Complies
Spurious Emissions at Antenna Terminals	90.210	2.1051	Mask	Complies
Radiated Spurious emission	90.210	2.1053	Mask	Complies
Frequency Stability	90.213	2.1055	1 ppm	NA

Frequency stability is not applicable because the device uses a common oscillator to up convert and down convert the RF signal. The EUT does not contain modulation circuitry, or frequency generation, therefore the test was not performed.

2 Equipment under test (E.U.T.)

2.1 Description

Kind of equipment	ION M4/8 19" Repeater
Andrew Ident. Number	Id.No. 7609239-0001
Serial no.(SN)	10
Revision	00
Software version and ID	RCM161RU19V01.00.00.09 Id.No. 7614712-00
Type of modulation and Designator	F3E (Voice) <input checked="" type="checkbox"/> F1D <input checked="" type="checkbox"/> F2D <input checked="" type="checkbox"/>
Frequency Translation	F1-F1 <input checked="" type="checkbox"/> F1-F2 <input type="checkbox"/> N/A <input type="checkbox"/>
Band Selection	Software <input type="checkbox"/> Duplexer <input checked="" type="checkbox"/> Full band <input type="checkbox"/>

2.1.1 Downlink

Pass band	Path 460.162 MHz – 462.988 MHz Path 470,775 MHz – 471,0 MHz Path 483.15 MHz - 483.58 MHz
Max. output power per path based on one carrier per path	30 dBm = 1 W
If the number of carrier is doubled, the power per carrier has to be reduced by 3dB	27dBm @ 2 carrier 24dBm @ 4 carrier 21dBm @ 8 carrier
Calculated maximum rated composite output power for all three path based on one carrier per path	34,77 dBm = 3 W
Gain	-3 dB @ Pout BTS of 33dBm

2.1.2 Uplink

Pass band	Path 465.162 MHz – 467.988 MHz Path 473,775 MHz – 474,0 MHz Path 486.15 MHz - 486.58 MHz
Gain	n.a.

Note: The EUT does not transmit over the air in the uplink direction.

2.1.3 Description of EUT

Andrew ION-M4/8 is a multi-band, multi-operator remote unit with various extension units. It is used in conjunction with a master unit in the ION optical distribution system.

This Test Report describes only the approval of the three 400 MHz Path (ION-M4).

The ION M4/8 19" Repeater consists of three 400 MHz paths and one 800 MHz path, with the intended use of simultaneous transmission

2.1.4 System diagrams

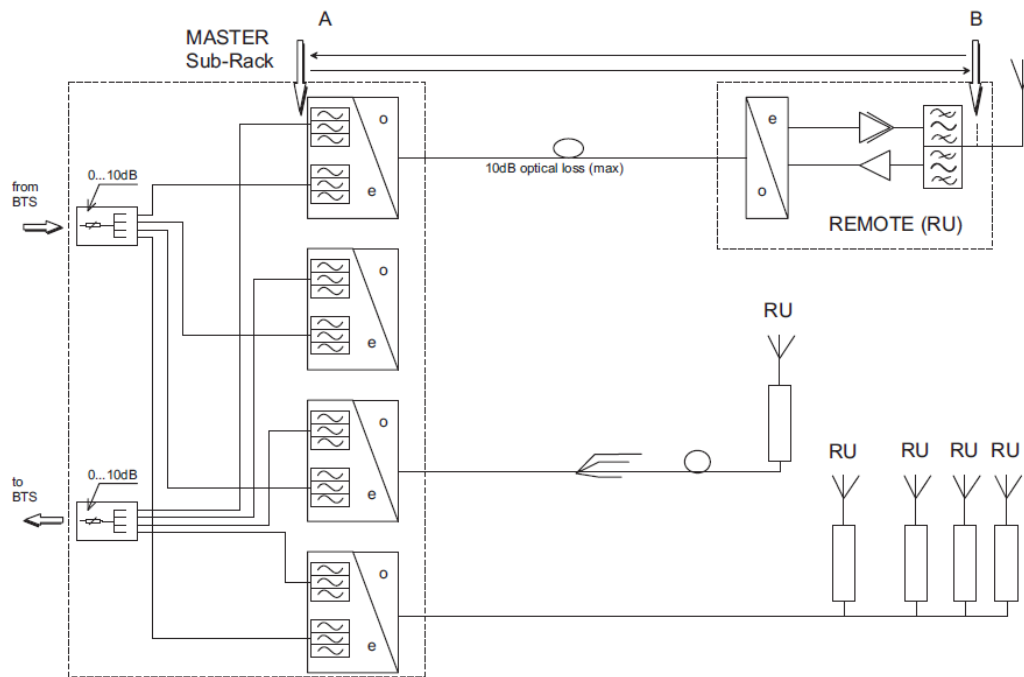

ION-M4/8 Design Principle Remote Unit

figure 2.1.4-#1 System diagrams: ION optical distribution system

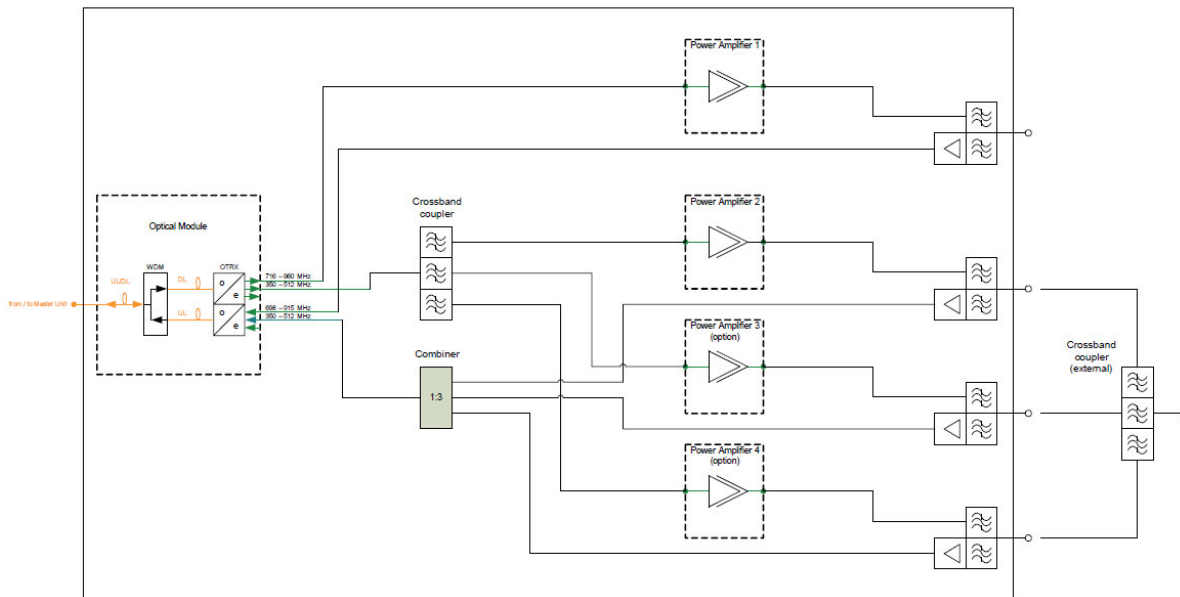

Design Principle ION-M System (One Subrack)

figure 2.1.4-#2 System diagrams: EUT is Remote Unit

2.1.5 Block diagram of measurement reference points

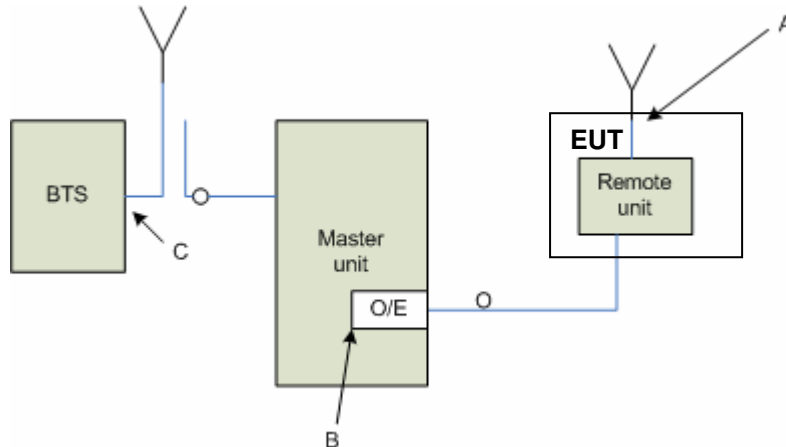

figure 2.1.5-#1 Block diagram of measurement reference points

Remote Unit is the EUT
 O/E Optilcal/Electrical converter
 SRMU SubRackMaster Unit

Reference point A, Remote Unit DL output, UL input
 Reference point B, SRMU UL output, DL input
 Reference point C, BTS DL output, UL input

3 Test site Buchdorf (Andrew)

3.1 Test environment

All tests were performed under the following environmental conditions:

Condition	Minimum value	Maximum value
Barometric pressure	86 kPa	106 kPa
Temperature	15°C	30°C
Relative Humidity	20 %	75 %
Power supply range	±5% of rated voltages	

3.2 Test equipment

ANDREW Inv. No.	Test equipment	Type	Manufacturer	Serial No.	Calibration
8917	Network Analyzer	ZVCE8	R&S	827712/009	01/10
8845	Spectrum Analyzer	FSP13	R&S	100387	04/10
8877	Signal Generator	E4438C	Agilent	MY42082954	01/10
8990	Signal Generator	SMJ100A	R&S	101288	11/10
8671	Power Meter	E4418B	Agilent	GB39513094	06/10
8672	Power Sensor	E9300H	Agilent	US41090179	06/10
7280	Power Attenuator	769-30	Narda	9395	CIU
7129	Power Amplifier	3-Band Amp	Andrew	---	CIU
7130	Power Amplifier	3-Band Amp	Andrew	---	CIU
7119	Divider	2way	Mikom	3512	CIU
7363	RF-Cable	2,0m; N-N	Huber & Suhner	28439/4PEA	CIU
7295	RF-Cable	2,5m; N-N	Huber & Suhner	28964/4PEA	CIU
7299	RF-Cable	2,5m; N-N	Huber & Suhner	28964/4PEA	CIU
7364	RF-Cable	1,0m; SMA	Huber & Suhner	36309/4P	CIU
7365	RF-Cable	1,0m; SMA	Huber & Suhner	36292/4P	CIU
7366	RF-Cable	2,0m; SMA	Huber & Suhner	36183/4P	CIU
7367	RF-Cable	2,0m; SMA	Huber & Suhner	36158/4P	CIU
7373	RF-Cable	Multiflex141 0,6m	Andrew	---	CIU
7374	RF-Cable	Multiflex141 0,6m	Andrew	---	CIU

CIU = Calibrate in use

3.3 Input and output losses

All recorded power levels should be referenced to the input and output connectors of the repeater, unless explicitly stated otherwise.

The test equipment used in this test has to be calibrated, so that the functionality is also checked.

All cables, attenuators, splitter, isolator, circulator and combiner etc. must be measured before testing and used for compensation during testing.

4 RF Power Out: §90.635, §2.1046

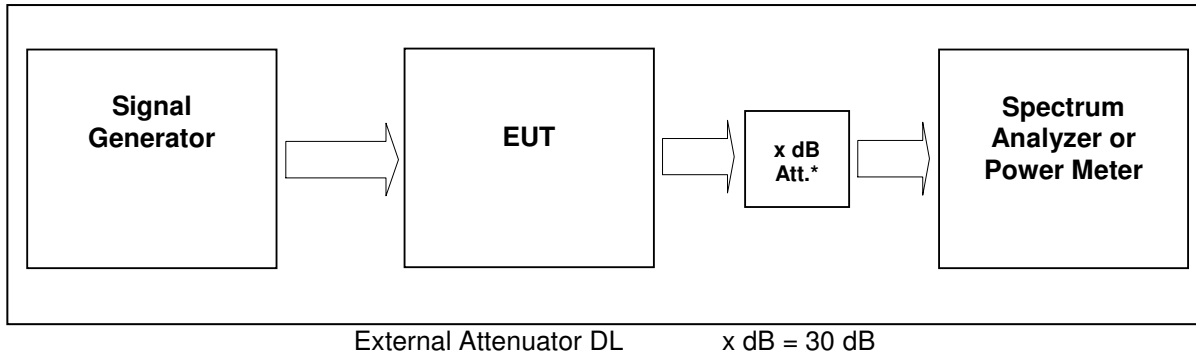

figure 4-#1 Test setup: RF Power Out: §90.635, §2.1046

Measurement uncertainty	± 0,38 dB
Test equipment used	8877, 8990, 7373, 7374, 7129, 7130, 7119, 7366, 7367, 7363, 7280, 7364

4.1 Limit

Minimum standard:

Para. No. 90.635 Limitations on power and antenna height.

(a) The effective radiated power and antenna height for base stations may not exceed 1 kilowatt (30 dBw) and 304 m. (1,000 ft.) above average terrain (AAT), respectively, or the equivalent thereof as determined from the Table. These are maximum values, and applicants will be required to justify power levels and antenna heights requested.

4.2 Test method

§ 2.1046 Measurements required: RF power output.

(a) For transmitters other than single sideband, independent sideband and controlled carrier radiotelephone, power output shall be measured at the RF output terminals when the transmitter is adjusted in accordance with the tune-up procedure to give the values of current and voltage on the circuit elements specified in § 2.1033(c)(8). The electrical characteristics of the radio frequency load attached to the output terminals when this test is made shall be stated.

(c) For measurements conducted pursuant to paragraphs (a) and (b) of this section, all calculations and methods used by the applicant for determining carrier power or peak envelope power, as appropriate, on the basis of measured power in the radio frequency load attached to the transmitter output terminals shall be shown. Under the test conditions specified, no components of the emission spectrum shall exceed the limits specified in the applicable rule parts as necessary for meeting occupied bandwidth or emission limitations.



4.3 Test results

For peak power measurements: Detector peak max.
 For average power measurements: Detector RMS.

Test signal Analog:
 FM signal with 3.0 kHz deviation and 2.5 kHz rate and sine waveform.

Test signal FSK:
 Mod. Type 4-LVI FSK; Symbolrate 25ksps; Filter roll off 0,35; Data: PN23

According to ANSI C63.4 section 13.1 Table 5 for operating frequencies more then 10MHz: The test shall be performed at Bottom, Middle, Top frequencies.

4.3.1 Downlink

Modulation	Measured at		RBW VBW Span	Average Power (dBm)	RF Power (W)	Plot -
Analog	Bottom	460,262 MHz	1kHz 3kHz 50kHz	30,1	1,02	4.3.1.1 #1
	Bottom	460,262 MHz		30,1	1,02	#2
	Middle	470,9 MHz		30,1	1,02	#3
	Middle	470,9 MHz				
	Top	483,5625 MHz				
	Top	483,5625 MHz				
FSK	Bottom	460,262 MHz	10kHz 30kHz 500kHz	30,1	1,02	4.3.1.2 #1
	Bottom	460,262 MHz		30,0	1,0	#2
	Middle	470,9 MHz		29,7	0,93	#3
	Middle	470,9 MHz				
	Top	483,5625 MHz				
	Top	483,5625 MHz				
Maximum output power = 30,1 dBm = 1,02 W						
Limit Maximum output power = 1000 W = 60dBm						

table 4.3.1-#1 RF Power Out: §90.635, §2.1046 Test results Downlink

Modulation	Pin / dBm (Ref. point B)
Analog	-5,2
FSK	-5,2

table 4.3.1-#2 RF Power Out: §90.635, §2.1046 Test results Downlink Input power



4.3.1.1 Analog

Limit 60 dBm

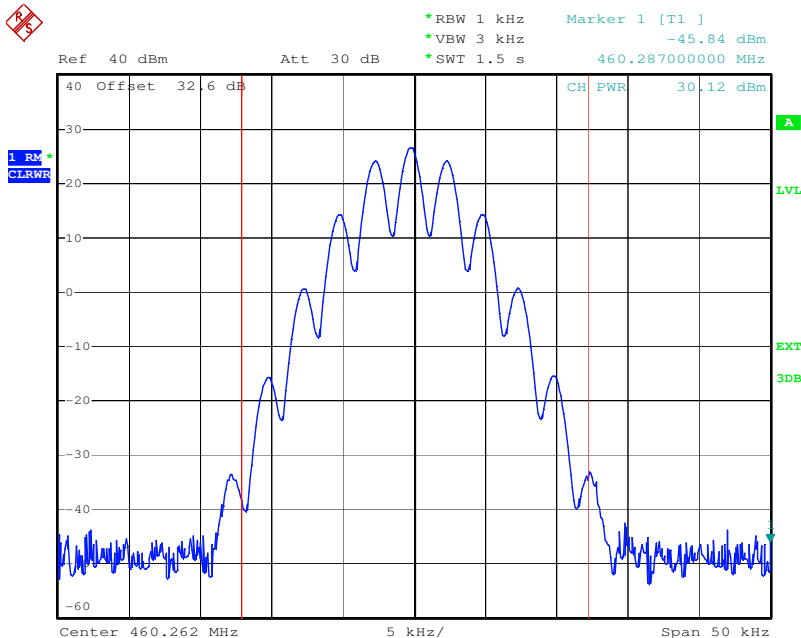

Date: 19.NOV.2009 09:41:52

plot 4.3.1.1-#1 RF Power Out: §90.635, §2.1046; Test results; Downlink; Analog Bottom RMS

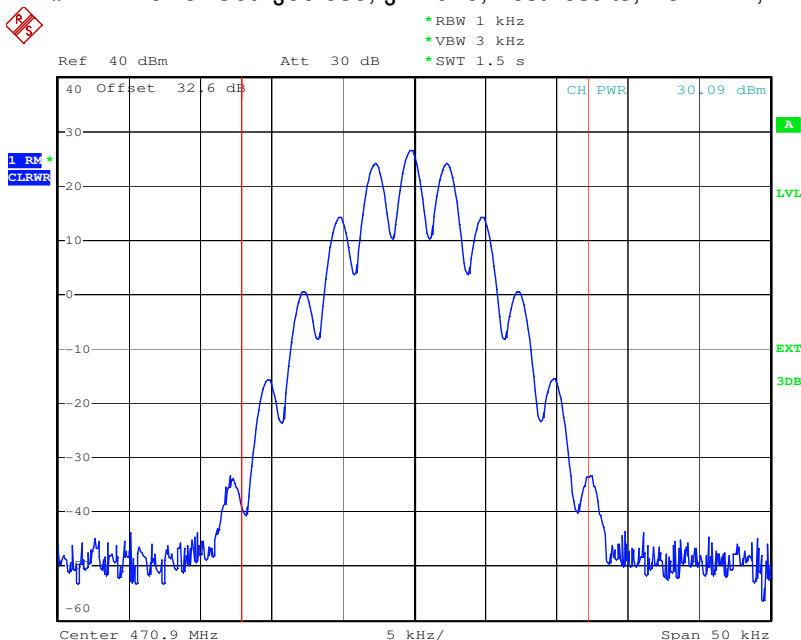

Date: 18.NOV.2009 18:35:37

plot 4.3.1.1-#2 RF Power Out: §90.635, §2.1046; Test results; Downlink; Analog Middle RMS

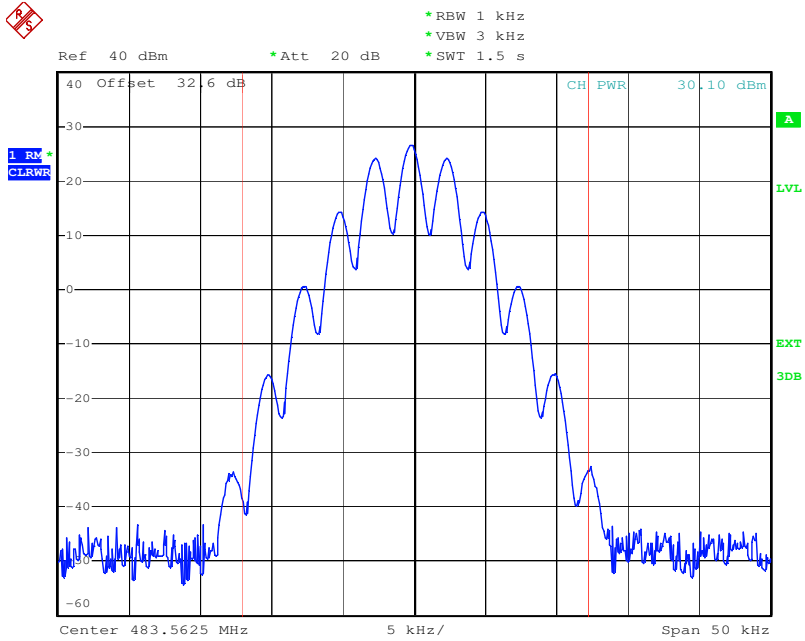

Date: 18.NOV.2009 14:32:39

plot 4.3.1.1-#3 RF Power Out: §90.635, §2.1046; Test results; Downlink; Analog Top RMS



4.3.1.2 FSK

Limit 60 dBm

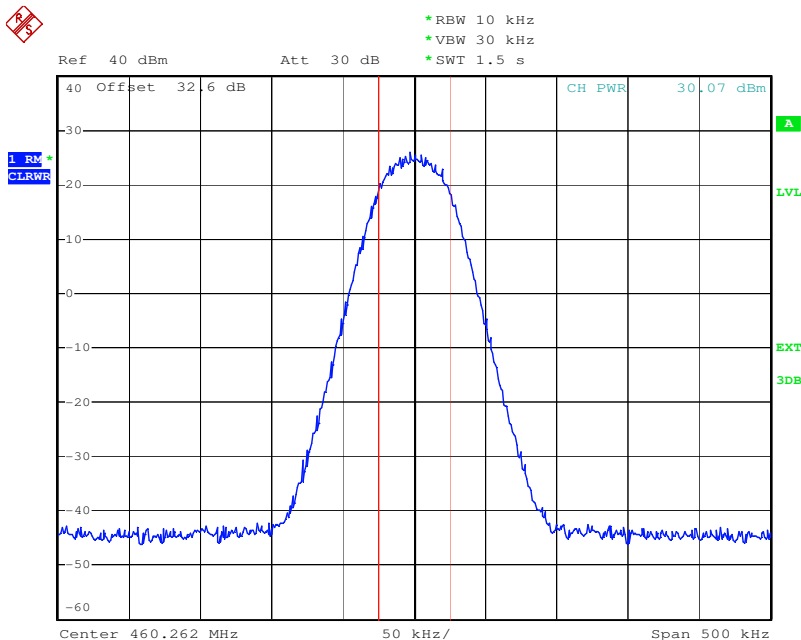

Date: 19.NOV.2009 09:49:07

plot 4.3.1.2-#1 RF Power Out: §90.635, §2.1046; Test results; Downlink; FSK Bottom RMS

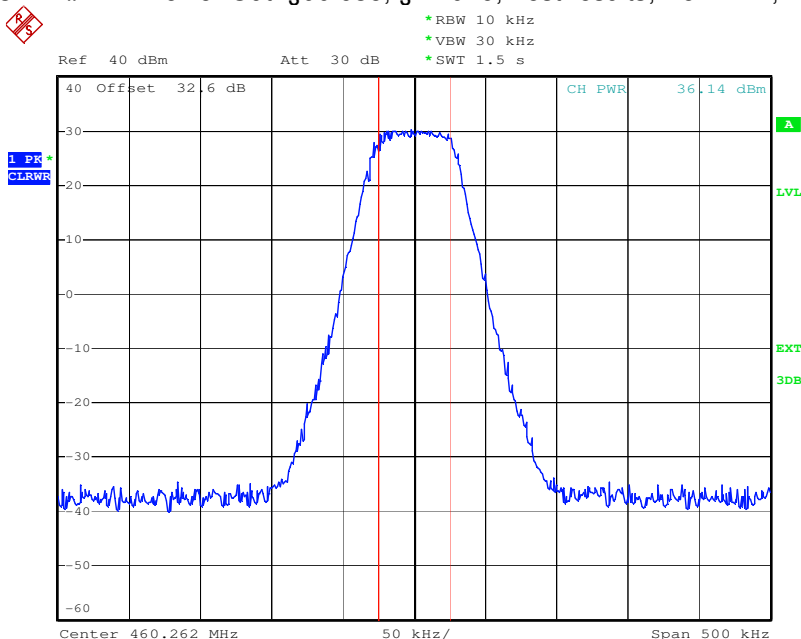

Date: 19.NOV.2009 09:49:18

plot 4.3.1.2-#2 RF Power Out: §90.635, §2.1046; Test results; Downlink; FSK Bottom Peak

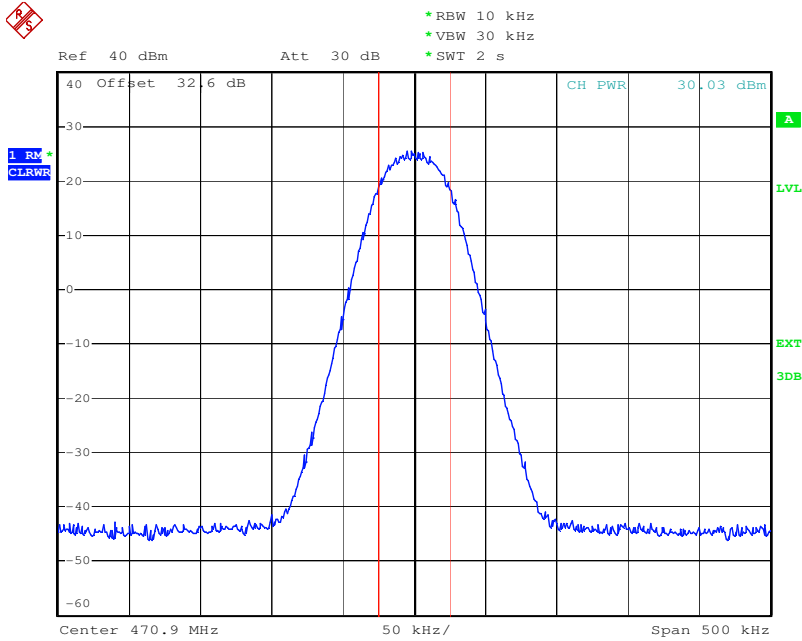

Date: 18.NOV.2009 18:08:39

plot 4.3.1.2-#3 RF Power Out: §90.635, §2.1046; Test results; Downlink; FSK Middle RMS

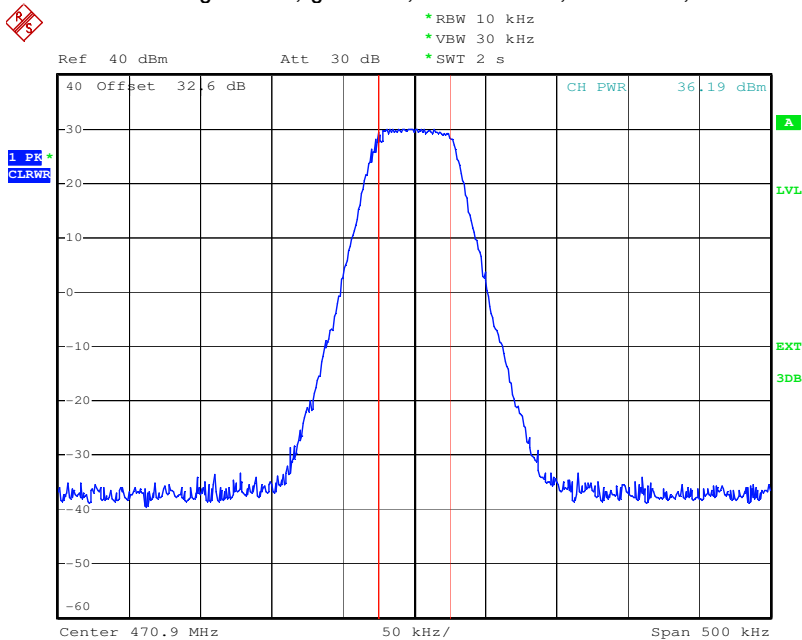

Date: 18.NOV.2009 18:08:57

plot 4.3.1.2-#4 RF Power Out: §90.635, §2.1046; Test results; Downlink; FSK Middle Peak

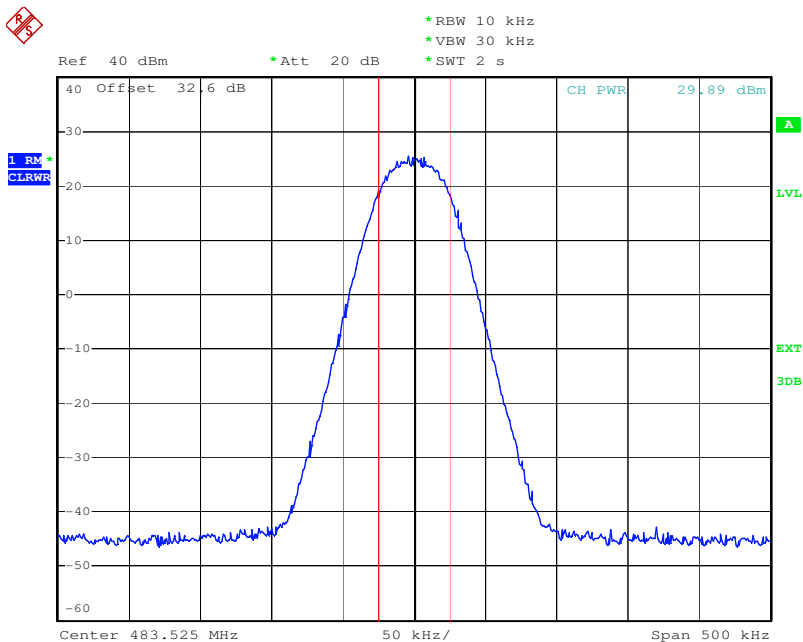

Date: 18.NOV.2009 14:21:14

plot 4.3.1.2-#5 RF Power Out: §90.635, §2.1046; Test results; Downlink; FSK Top RMS

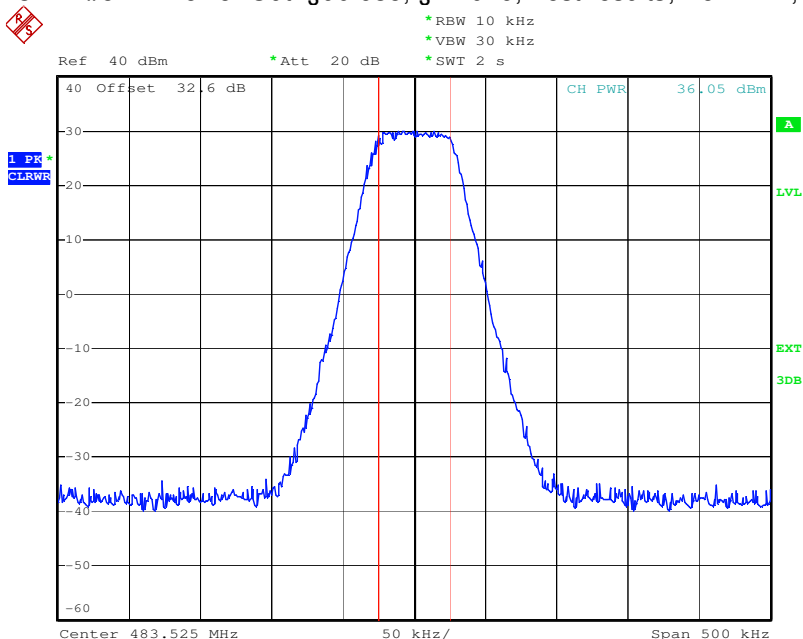

Date: 18.NOV.2009 14:21:28

plot 4.3.1.2-#6 RF Power Out: §90.635, §2.1046; Test results; Downlink; FSK Top Peak



4.3.2 Uplink

n.a.

Note: The EUT does not transmit over the air in the uplink direction.

4.4 Summary test result

Test result	complies, according the plots above
Tested by:	Michael Leinfelder
Date:	18.11.2009

5 Occupied Bandwidth: §90.210, §2.1049

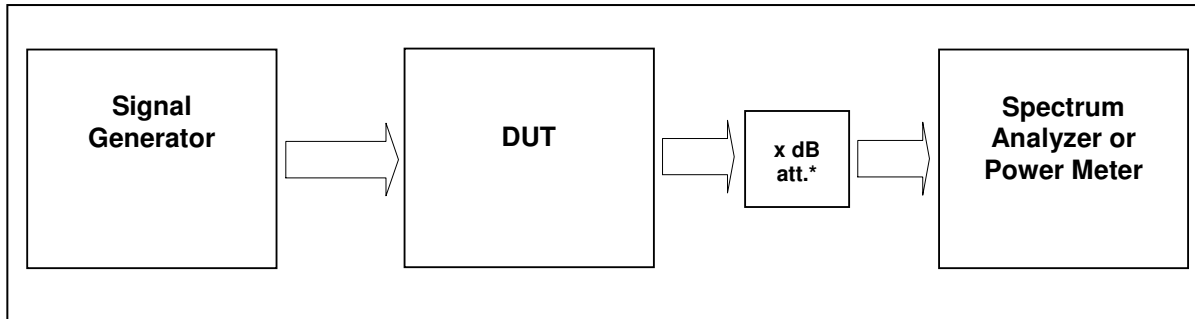

External Attenuator DL x dB = 30 dB
 figure 5-#1 Test setup: Occupied Bandwidth: §90.210, §2.1049

Measurement uncertainty	± 0,38 dB
Test equipment used	8877, 8990, 7373, 7374, 7129, 7130, 7119, 7366, 7367, 7363, 7280, 7364

5.1 Limit

The spectral shape of the output should look similar to input for all modulations.

5.2 Test method

Para. No.2.1049

The occupied bandwidth, that is the frequency bandwidth such that, below its lower and above its upper frequency limits, the mean powers radiated are each equal to 0.5 percent of the total mean power radiated by a given emission shall be measured under the following conditions as applicable:



5.3 Test results

For average power measurements: Detector RMS.

Modulation	Link	Measure d at		RBW VBW Span	Occupied Bandwidth / kHz	Plot #
Analog	Downlink	Middle	461,575 MHz	1kHz 3kHz 50kHz	11,0	5.3.1.1 #1, #2
FSK	Downlink	Middle	461,575 MHz	10kHz 30kHz 500kHz	72,0	5.3.1.2 #1, #2
Analog	Downlink	Middle	470,8875 MHz	1kHz 3kHz 50kHz	11,0	5.3.1.3 #1, #2
FSK	Downlink	Middle	470,8875 MHz	10kHz 30kHz 500kHz	72,0	5.3.1.4 #1, #2
Analog	Downlink	Middle	483,3625 MHz	1kHz 3kHz 50kHz	11,0	5.3.1.5 #1, #2
FSK	Downlink	Middle	483,3625 MHz	10kHz 30kHz 500kHz	72,0	5.3.1.6 #1, #2
Analog	Uplink	n.a.				
FSK	Uplink	n.a.				

table 5.3-#1 Occupied Bandwidth: §90.210, §2.1049 Test results



5.3.1 Downlink

5.3.1.1 Analog

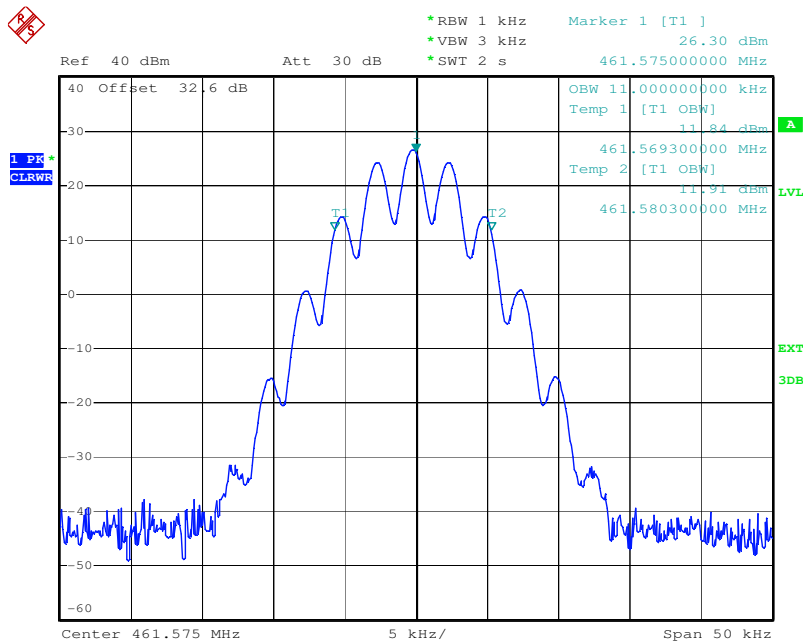

Date: 19.NOV.2009 09:52:44

plot 4.3.1.2-#1 Occupied Bandwidth: §90.210, §2.1049; Test results; Downlink; FSK Output

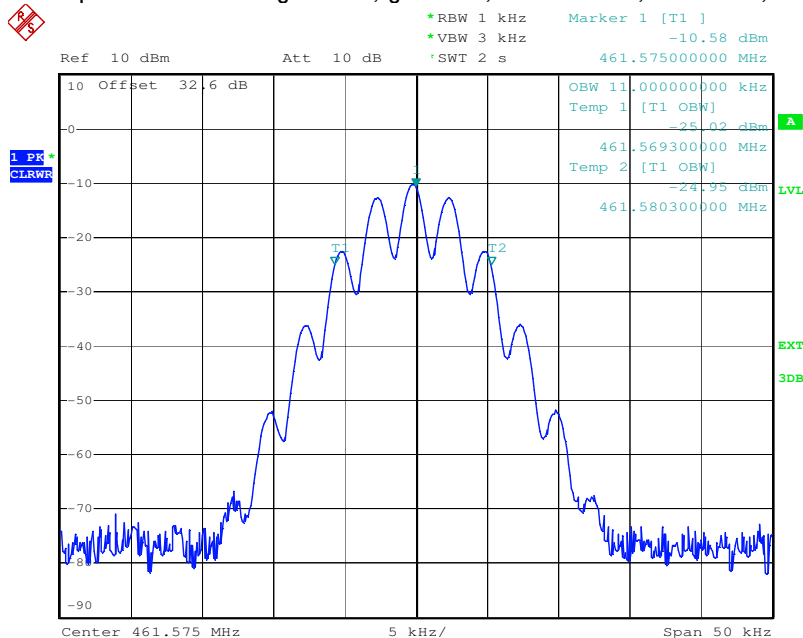

Date: 19.NOV.2009 09:53:15

plot 4.3.1.2-#2 Occupied Bandwidth: §90.210, §2.1049; Test results; Downlink; FSK Input

5.3.1.2 FSK

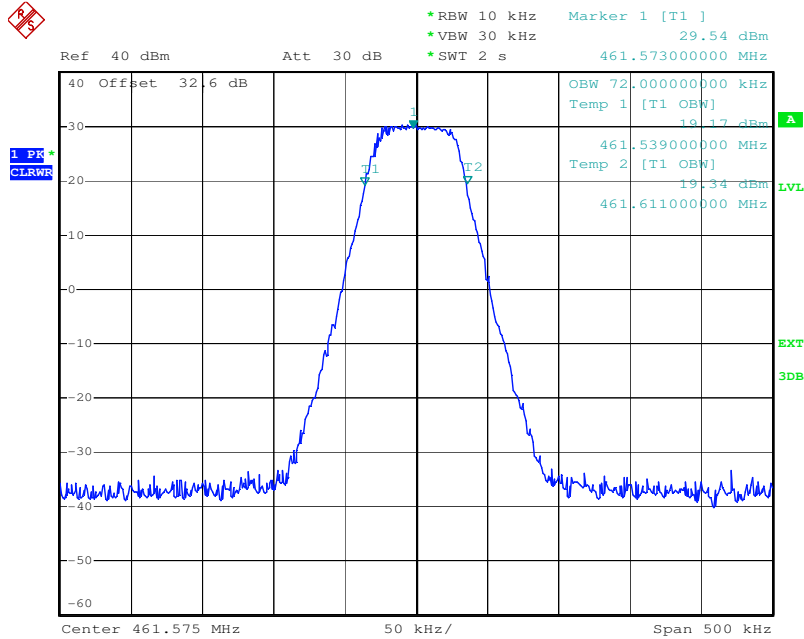

Date: 19.NOV.2009 09:51:06

plot 4.3.1.2-#3 Occupied Bandwidth: §90.210, §2.1049; Test results; Downlink; FSK Output

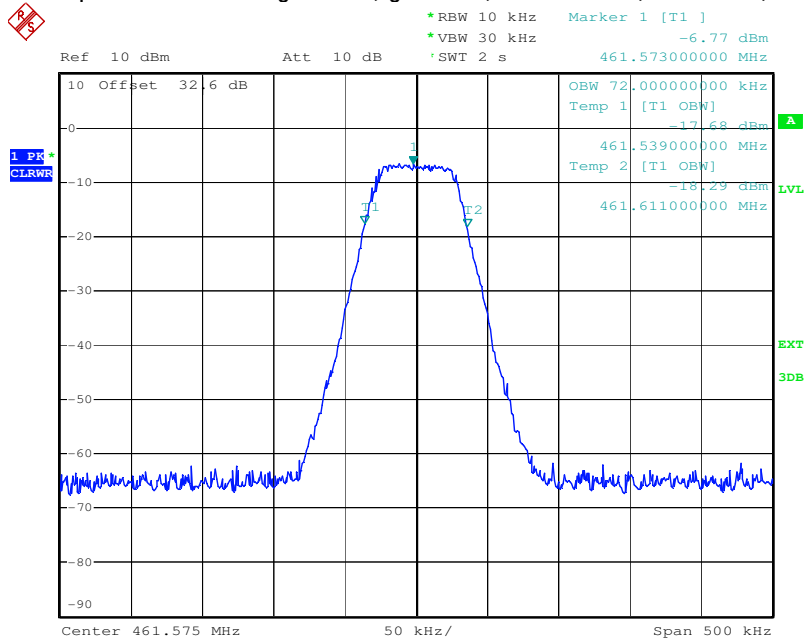

Date: 19.NOV.2009 09:51:36

plot 4.3.1.2-#4 Occupied Bandwidth: §90.210, §2.1049; Test results; Downlink; FSK Input



5.3.1.3 Analog

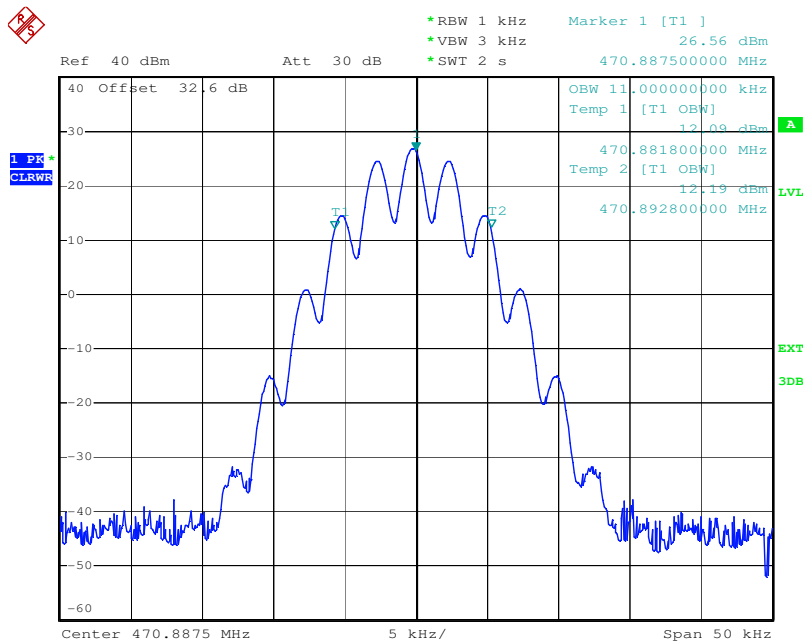

Date: 19.NOV.2009 09:29:13

plot 4.3.1.2-#5 Occupied Bandwidth: §90.210, §2.1049; Test results; Downlink; FSK Output

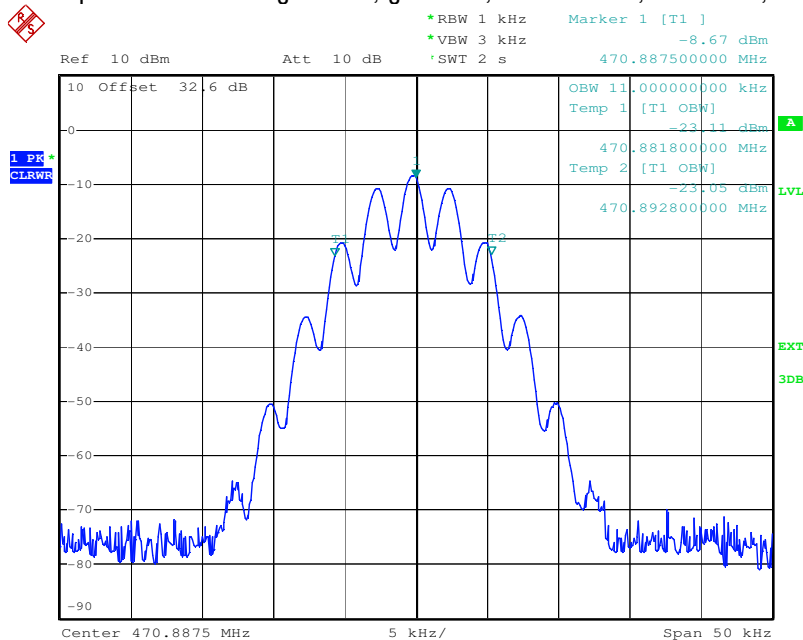

Date: 19.NOV.2009 09:29:45

plot 4.3.1.2-#6 Occupied Bandwidth: §90.210, §2.1049; Test results; Downlink; FSK Input

5.3.1.4 FSK

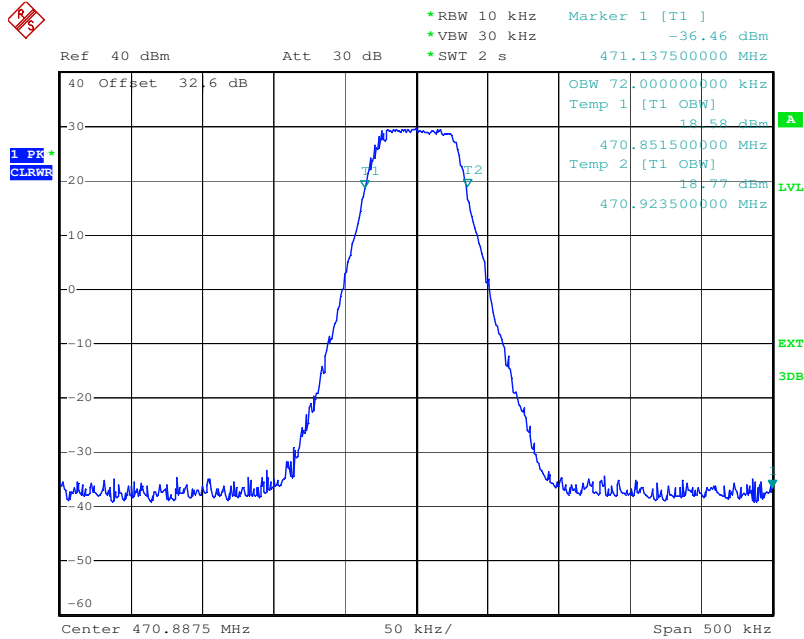

Date: 19.NOV.2009 09:25:00

plot 4.3.1.2-#7 Occupied Bandwidth: §90.210, §2.1049; Test results; Downlink; FSK Output

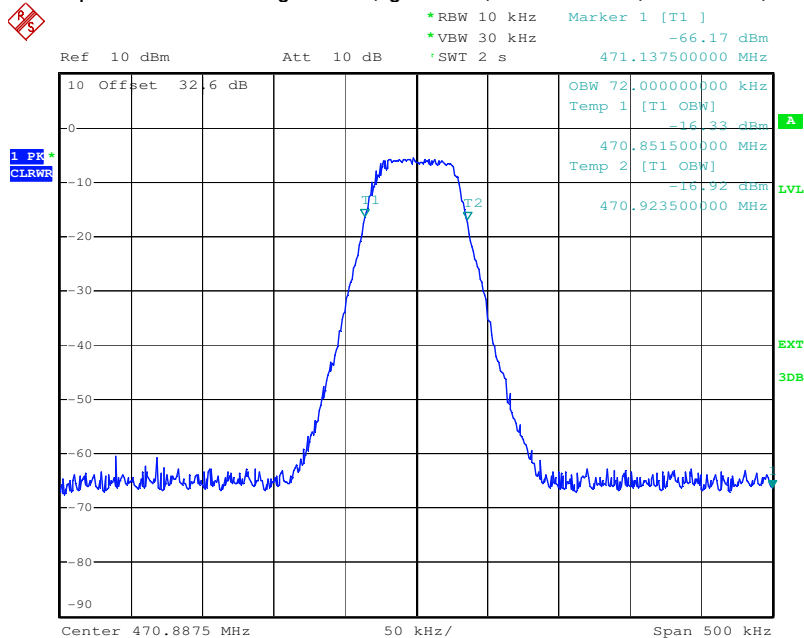

Date: 19.NOV.2009 09:25:35

plot 4.3.1.2-#8 Occupied Bandwidth: §90.210, §2.1049; Test results; Downlink; FSK Input



5.3.1.5 Analog

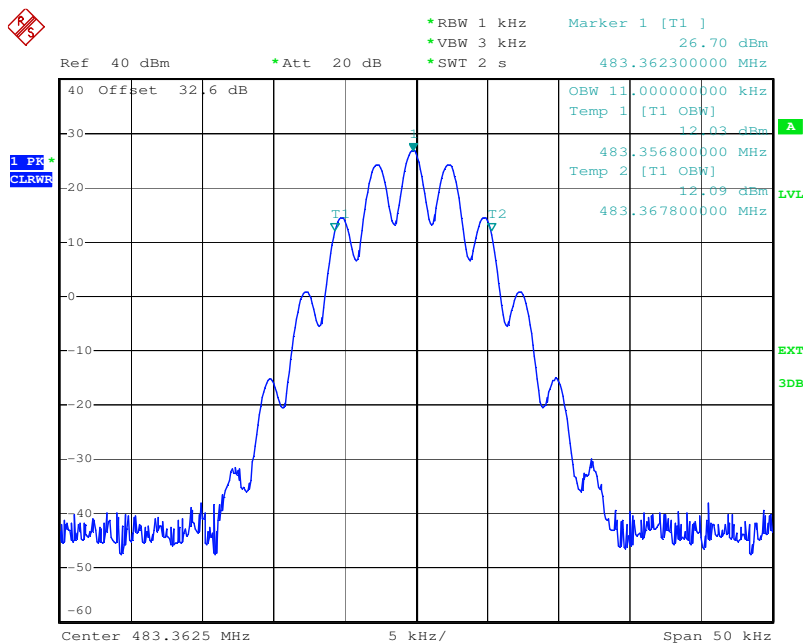

Date: 18.NOV.2009 14:40:18

plot 5.3.1.5-#1 Occupied Bandwidth: §90.210, §2.1049; Test results; Downlink; Analog Output

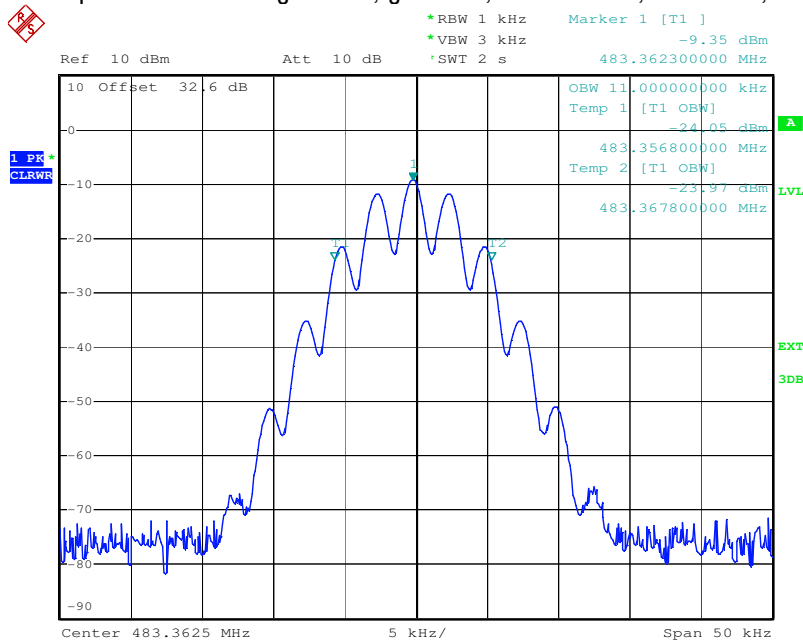

Date: 18.NOV.2009 14:40:48

plot 5.3.1.5-#2 Occupied Bandwidth: §90.210, §2.1049; Test results; Downlink; Analog Input

5.3.1.6 FSK

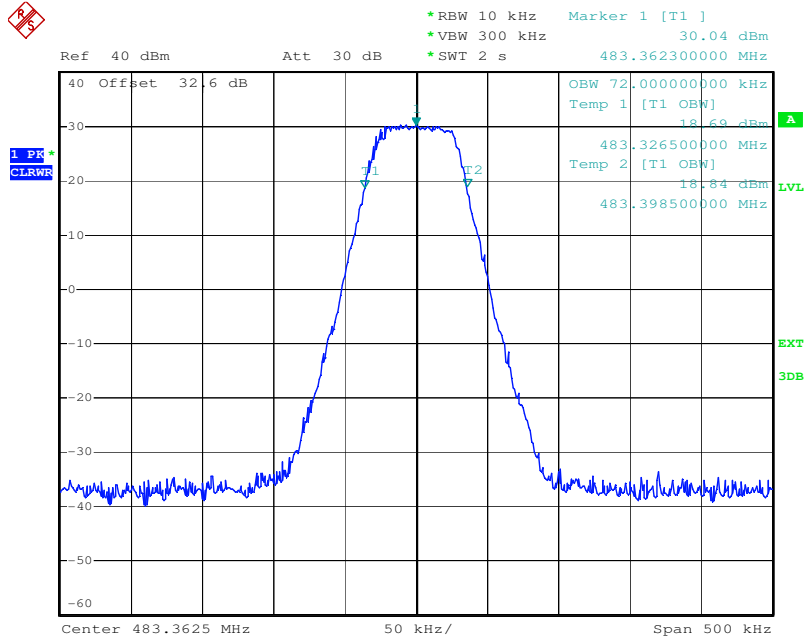

Date: 18.NOV.2009 14:42:05

plot 5.3.1.6-#1 Occupied Bandwidth: §90.210, §2.1049; Test results; Downlink; FSK Output

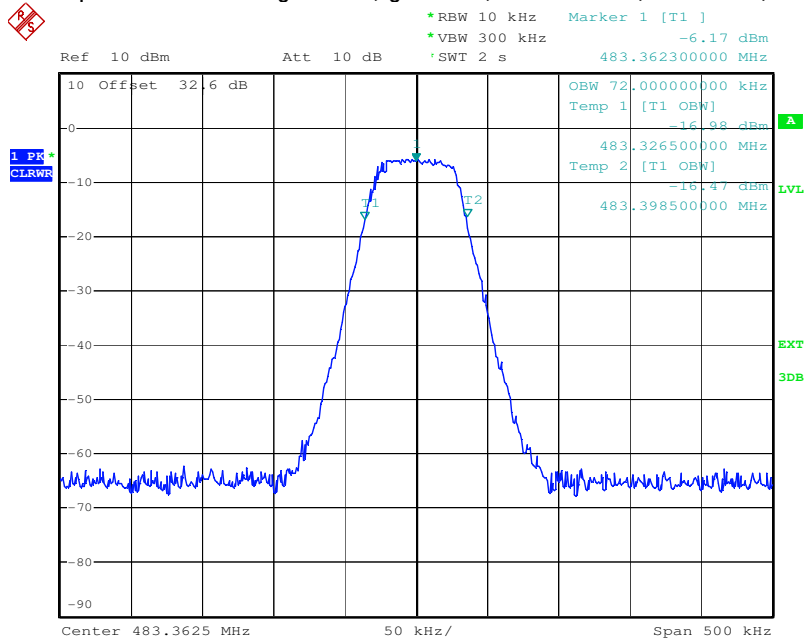

Date: 18.NOV.2009 14:42:38

plot 5.3.1.6-#2 Occupied Bandwidth: §90.210, §2.1049; Test results; Downlink; FSK Input



5.3.2 Uplink

n.a.

Note: The EUT does not transmit over the air in the uplink direction.

5.4 Summary test result

Test result	complies, according the plots above
Tested by:	Michael Leinfelder
Date:	18.11.2009

6 Spurious Emissions at Antenna Terminals: §90.210, §2.1051

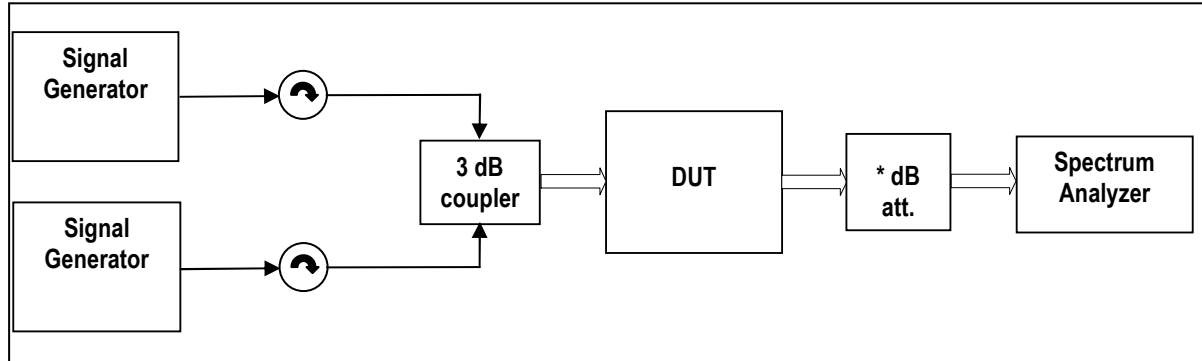

External Attenuator DL x dB = 30 dB

figure 6-#1 Test setup: Spurious Emissions at Antenna Terminals: §90.210, §2.1051

Measurement uncertainty	± 0,54 dB ± 1,2 dB ± 1,5 dB	9 kHz to 3 GHz 3 GHz to 7 GHz 7 GHz to 26 GHz
Test equipment used	8877, 8990, 7373, 7374, 7129, 7130, 7119, 7366, 7367, 7363, 7280, 7364	

6.1 Limit

Minimum standard: §90.210, Table “Application Emission Mask”

Frequency Band (MHz)	Mask for equipment with Audio Low pass filter	Mask for Equipment without audio low pass filter
421-512 ²	B, D, or E	C, D or E

²Equipment designed to operate with a 25 kHz channel bandwidth must meet the requirements of Emission Mask B or C, as applicable. Equipment designed to operate with a 12.5 kHz channel bandwidth must meet the requirements of Emission Mask D, and equipment designed to operate with a 6.25 kHz channel bandwidth must meet the requirements of Emission Mask E.

MASK	Spurious Limit
A,B,C,G,H,I	-13dBm

6.2 Test method

Para. No 2.1051 Measurements required: Spurious emissions at antenna terminals.

The radio frequency voltage or powers generated within the equipment and appearing on a spurious frequency shall be checked at the equipment output terminals when properly loaded with a suitable artificial antenna. Curves or equivalent data shall show the magnitude of each harmonic and other spurious emission that can be detected when the equipment is operated under the conditions specified in § 2.1049 as appropriate. The magnitude of spurious emissions which are attenuated more than 20 dB below the permissible value need not be specified.

[39 FR 5919, Feb. 15, 1974. Redesignated and amended at 63 FR 36599, July 7, 1998]



6.3 Test results

<1MHz from Band Edge

Detector: RMS.

Modulation	Measured at Band Edge		RBW VBW Span	Max. level (dBm)	Plot -
Analog	Lower Edge	460,262 MHz	1kHz	-37,6	6.3.1.1 #1
		460,462 MHz	3kHz		#2
FSK	Lower Edge	462,688 MHz	2MHz	-47	6.3.1.2 #1
		462,888 MHz	2MHz		#2
Analog	Upper Edge	470,84 MHz	1kHz	-30,5	6.3.1.3 #1
		470,94 MHz	3kHz		#2
FSK	Upper Edge	470,84 MHz	1MHz	-42	6.3.1.4 #1
		470,94 MHz	1MHz		#2
Analog	Lower Edge	483,25 MHz	1kHz	-39,7	6.3.1.5 #1
		483,45 MHz	3kHz		#2
FSK	Lower Edge	483,275 MHz	2MHz	-49	6.3.1.6 #1
		483,475 MHz	3MHz		#2

table 6.3-#1 Spurious Emissions at Antenna Terminals: §90.210, §2.1051 Test results <1MHz from Band Edge



>1MHz from Band Edge

Detector: RMS.

Modulation	Measured at		Max. level (dBm)	Frequency range	Plot -
Analog	Bottom	460,262 MHz	-34	30MHz – 1GHz	6.3.1.7 #1
	Bottom	460,462 MHz		1GHz – 10GHz	#2
	Middle	470,84 MHz		30MHz – 1GHz	#3
	Middle	470,94 MHz		1GHz – 10GHz	#4
	Top	483,275 MHz		30MHz – 1GHz	#5
	Top	483,475 MHz		1GHz – 10GHz	#6
FSK	Bottom	460,262 MHz	-34	30MHz – 1GHz	6.3.1.8 #1
	Bottom	460,462 MHz		1GHz – 10GHz	#2
	Middle	470,84 MHz		30MHz – 1GHz	#3
	Middle	470,94 MHz		1GHz – 10GHz	#4
	Top	483,275 MHz		30MHz – 1GHz	#5
	Top	483,475 MHz		1GHz – 10GHz	#6

table 6.3-#2 Spurious Emissions at Antenna Terminals: §90.210, §2.1051 Test results

Start	Stop	RBW	VBW
30MHz	1GHz	1MHz	3MHz
1GHz	10GHz	1MHz	3MHz

table 6.3-#3 Spurious Emissions at Antenna Terminals: §90.210, §2.1051 Test results RBW, VBW Table



6.3.1 Downlink

6.3.1.1 Analog < 1MHz to band edge

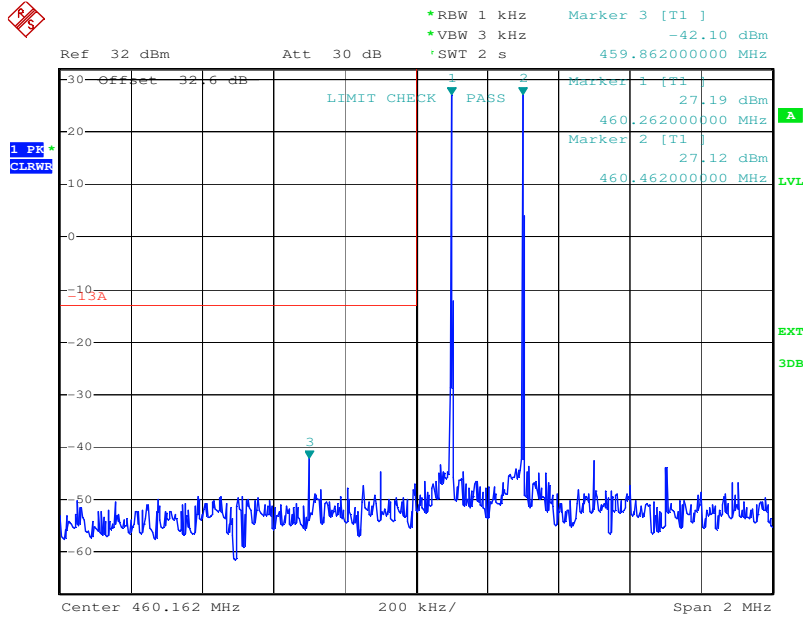

Date: 19.NOV.2009 10:01:20

plot 5.3.1.6-#1 Spurious Emissions at Antenna Terminals: §90.210, §2.1051; Test results; Downlink; FSK Lower Band Edge

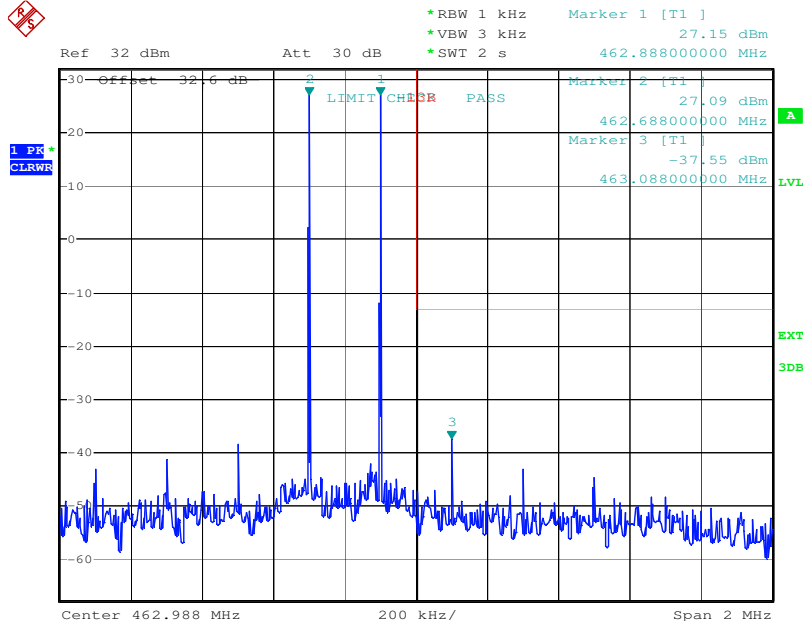

Date: 19.NOV.2009 10:04:16

plot 5.3.1.6-#2 Spurious Emissions at Antenna Terminals: §90.210, §2.1051; Test results; Downlink; FSK Upper Band Edge

6.3.1.2 FSK < 1MHz to band edge

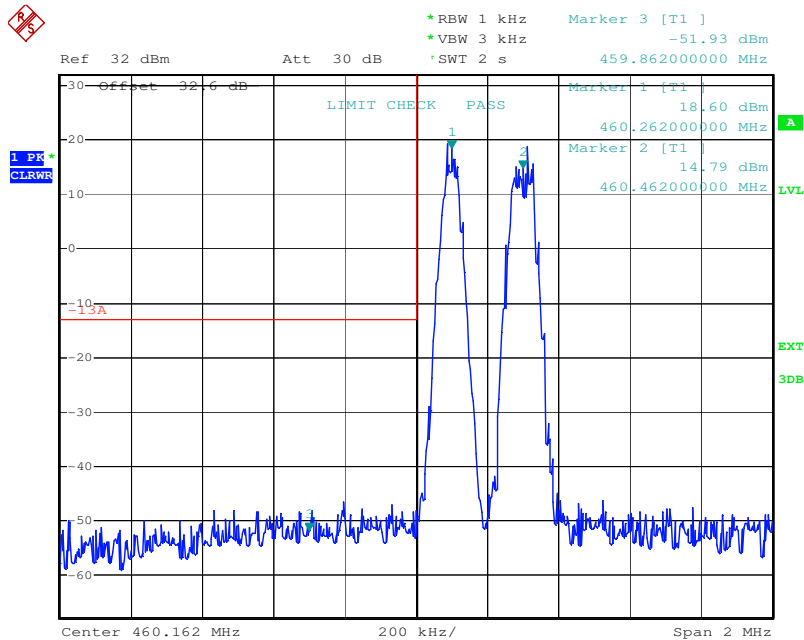

Date: 19.NOV.2009 10:01:44

plot 5.3.1.6-#3 Spurious Emissions at Antenna Terminals: §90.210, §2.1051; Test results; Downlink; FSK Lower Band Edge

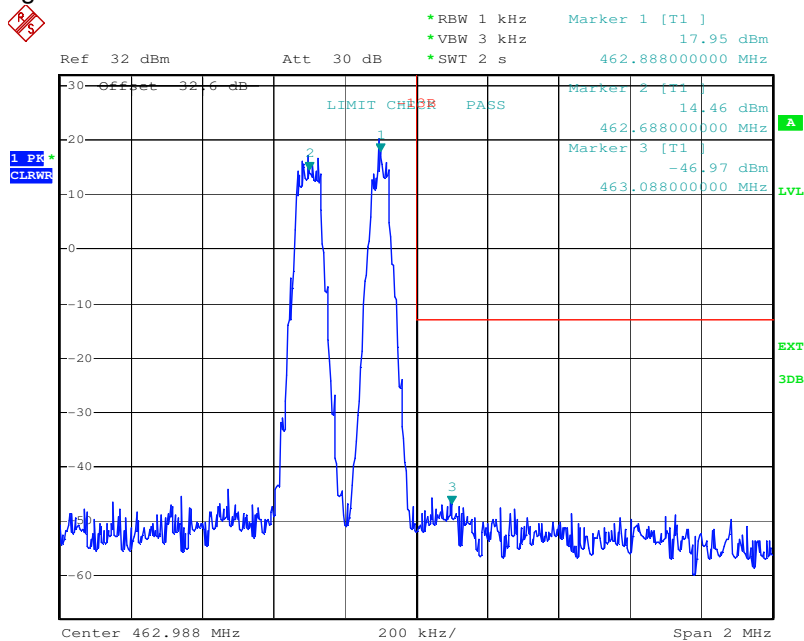

Date: 19.NOV.2009 10:04:34

plot 5.3.1.6-#4 Spurious Emissions at Antenna Terminals: §90.210, §2.1051; Test results; Downlink; FSK Upper Band Edge



6.3.1.3 Analog < 1MHz to band edge

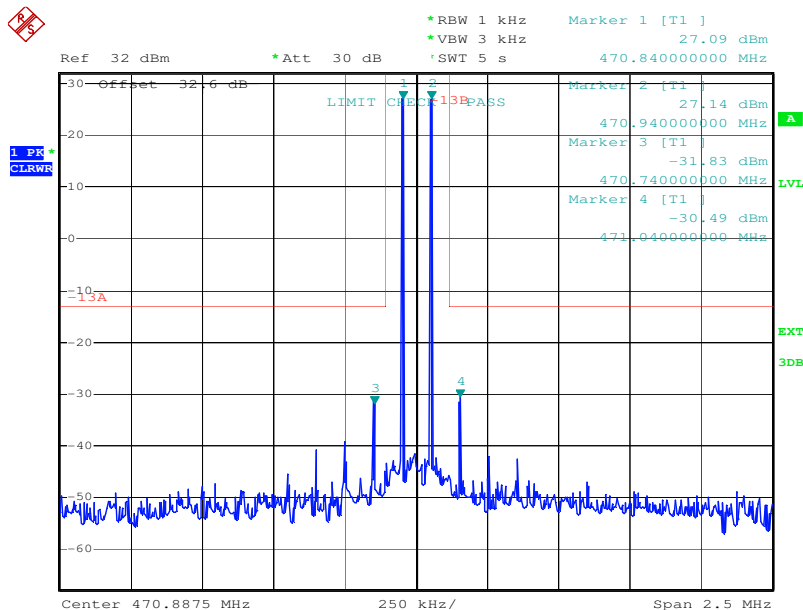

Date: 19.NOV.2009 09:09:26

plot 6.3.1.3-#1 Spurious Emissions at Antenna Terminals: §90.210, §2.1051; Test results; Downlink; Analog < 1MHz to band edge

6.3.1.4 FSK < 1MHz to band edge

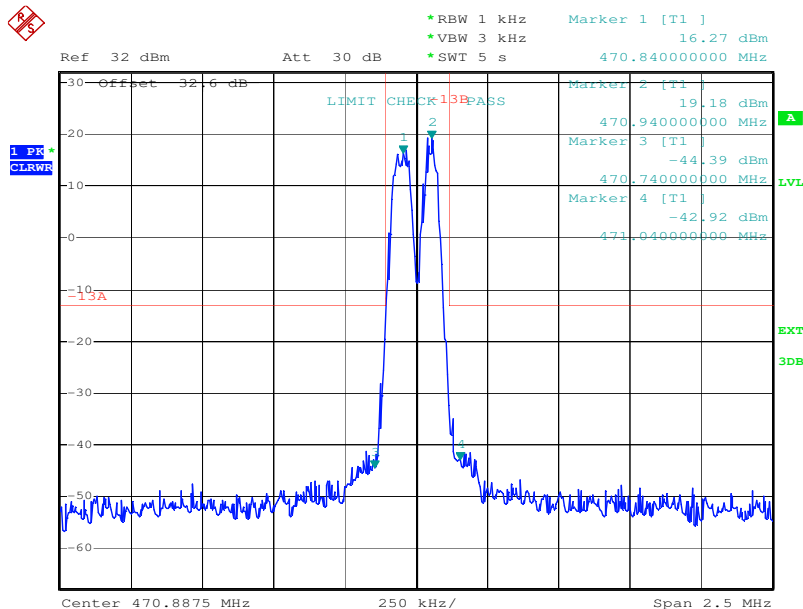

Date: 19.NOV.2009 08:47:12

plot 6.3.1.4-#1 Spurious Emissions at Antenna Terminals: §90.210, §2.1051; Test results; Downlink; FSK < 1MHz to band edge

6.3.1.5 Analog < 1MHz to band edge

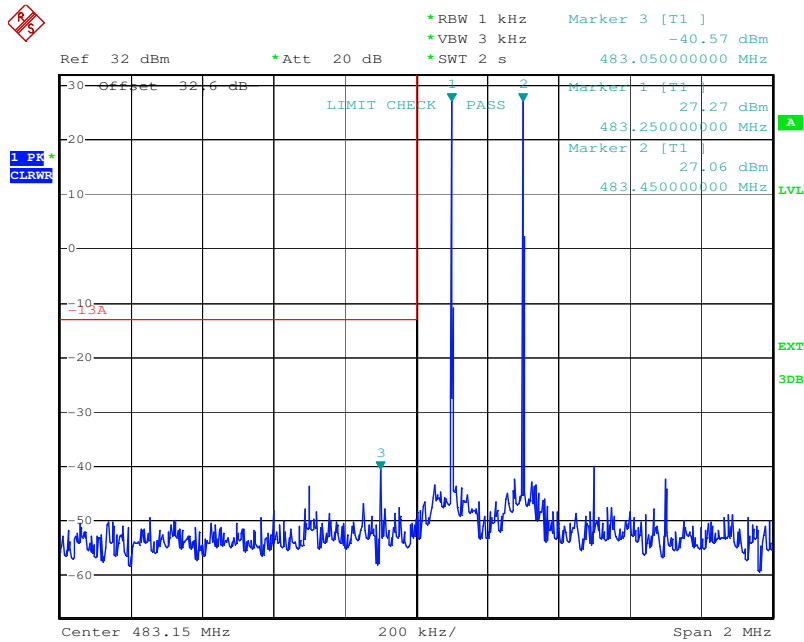

Date: 18.NOV.2009 15:43:35

plot 6.3.1.5-#1 Spurious Emissions at Antenna Terminals: §90.210, §2.1051; Test results; Downlink; Analog < 1MHz to band edge Lower Band Edge

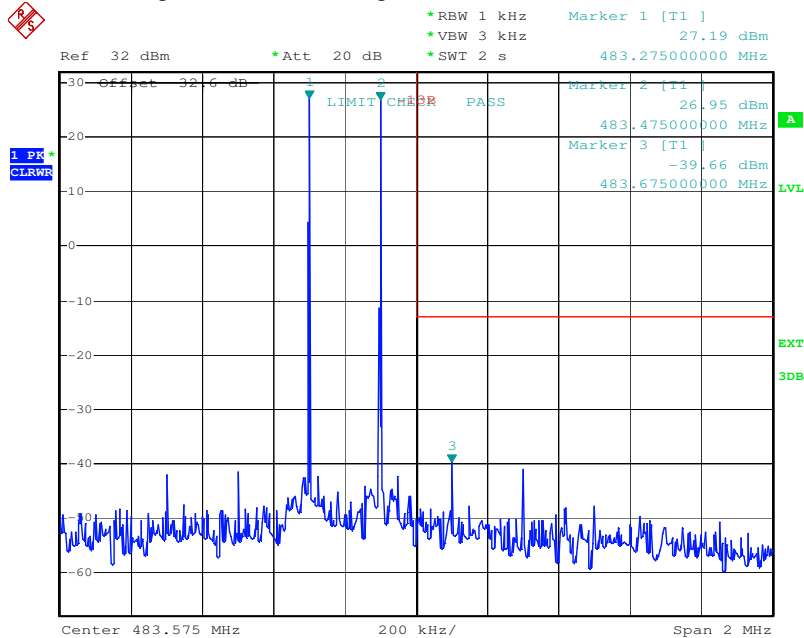

Date: 18.NOV.2009 15:42:19

plot 6.3.1.5-#2 Spurious Emissions at Antenna Terminals: §90.210, §2.1051; Test results; Downlink; Analog < 1MHz to band edge Upper Band Edge



6.3.1.6 FSK < 1MHz to band edge

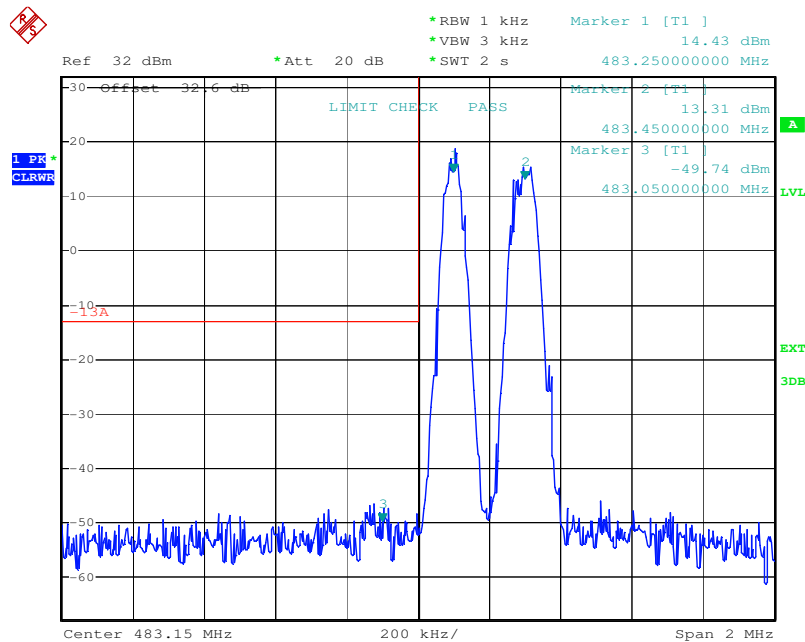

Date: 18.NOV.2009 14:48:56

plot 6.3.1.6-#1 Spurious Emissions at Antenna Terminals: §90.210, §2.1051; Test results; Downlink; FSK < 1MHz to band edge Lower Band Edge

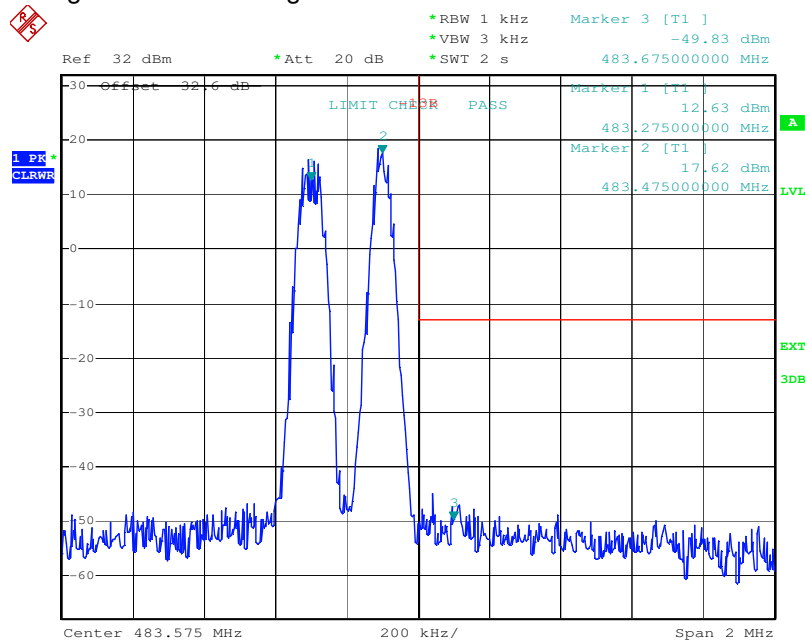

Date: 18.NOV.2009 15:41:29

plot 6.3.1.6-#2 Spurious Emissions at Antenna Terminals: §90.210, §2.1051; Test results; Downlink; FSK < 1MHz to band edge Upper Band Edge

6.3.1.7 Analog > 1MHz to band edge

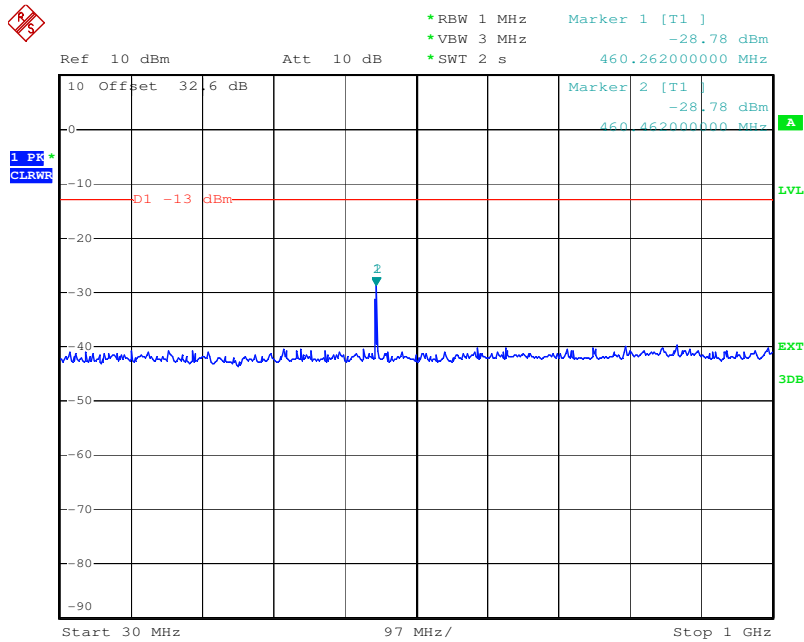

Date: 19.NOV.2009 10:40:21

plot 6.3.1.7-#1 Spurious Emissions at Antenna Terminals: §90.210, §2.1051; Test results; Downlink; Analog > 1MHz to band edge; Bottom; < 1 GHz; Carrier notched

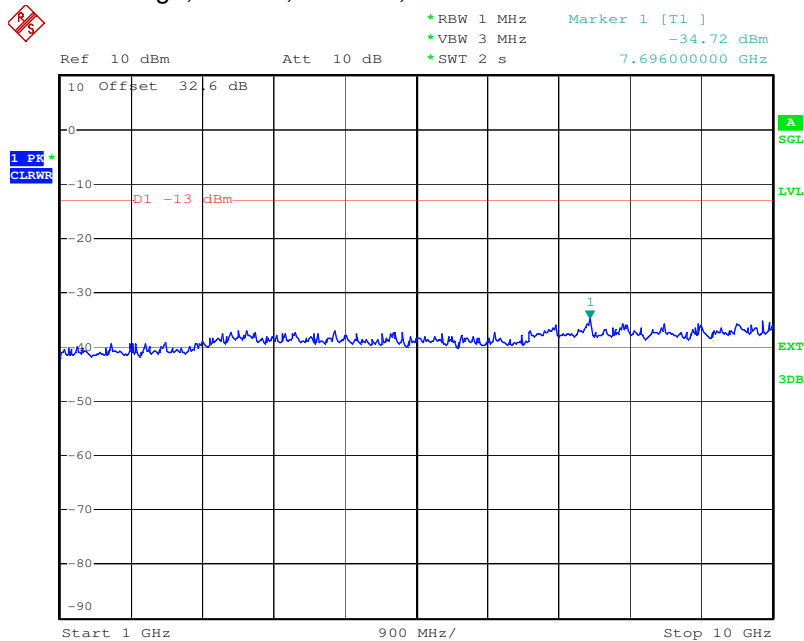

Date: 19.NOV.2009 10:39:01

plot 6.3.1.7-#2 Spurious Emissions at Antenna Terminals: §90.210, §2.1051; Test results; Downlink; Analog > 1MHz to band edge; Bottom; > 1 GHz

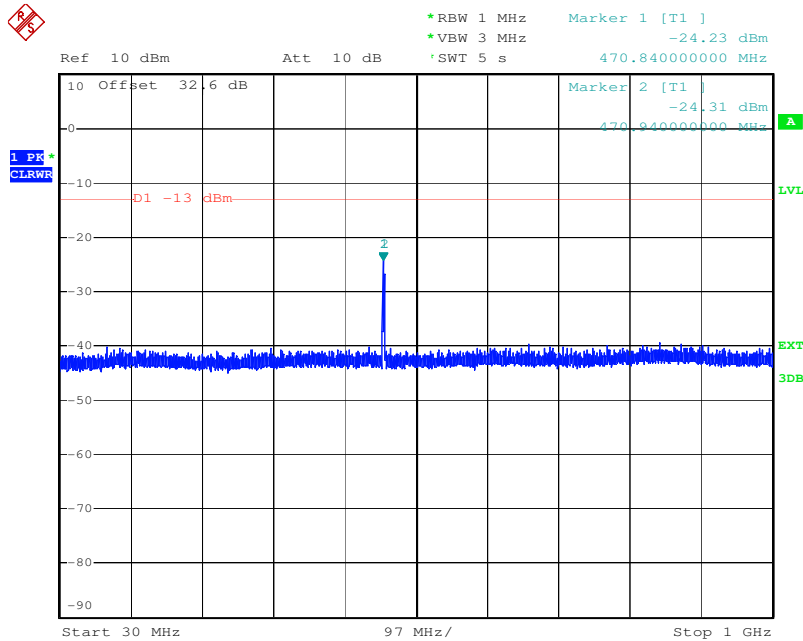

Date: 19.NOV.2009 09:14:24

plot 6.3.1.7-#3 Spurious Emissions at Antenna Terminals: §90.210, §2.1051; Test results; Downlink; Analog > 1MHz to band edge; Bottom; < 1 GHz; Carrier notched

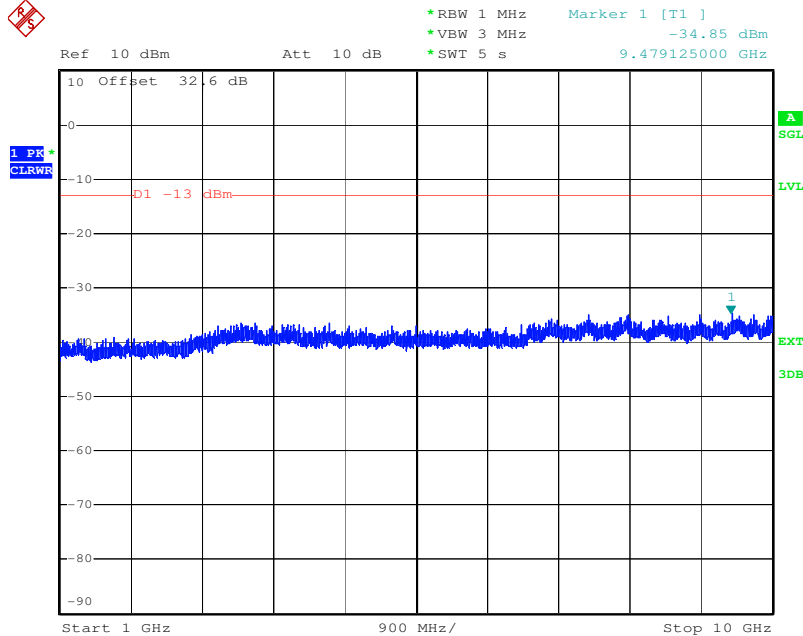

Date: 19.NOV.2009 09:16:19

plot 6.3.1.7-#4 Spurious Emissions at Antenna Terminals: §90.210, §2.1051; Test results; Downlink; Analog > 1MHz to band edge; Bottom; > 1 GHz

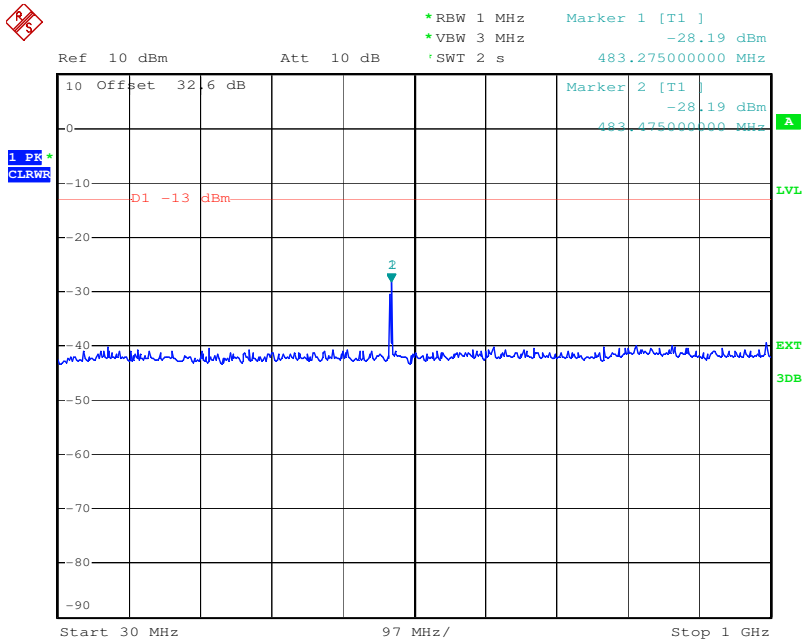

Date: 18.NOV.2009 16:10:10

plot 6.3.1.7-#5 Spurious Emissions at Antenna Terminals: §90.210, §2.1051; Test results; Downlink; Analog > 1MHz to band edge; Top; < 1 GHz; Carrier notched

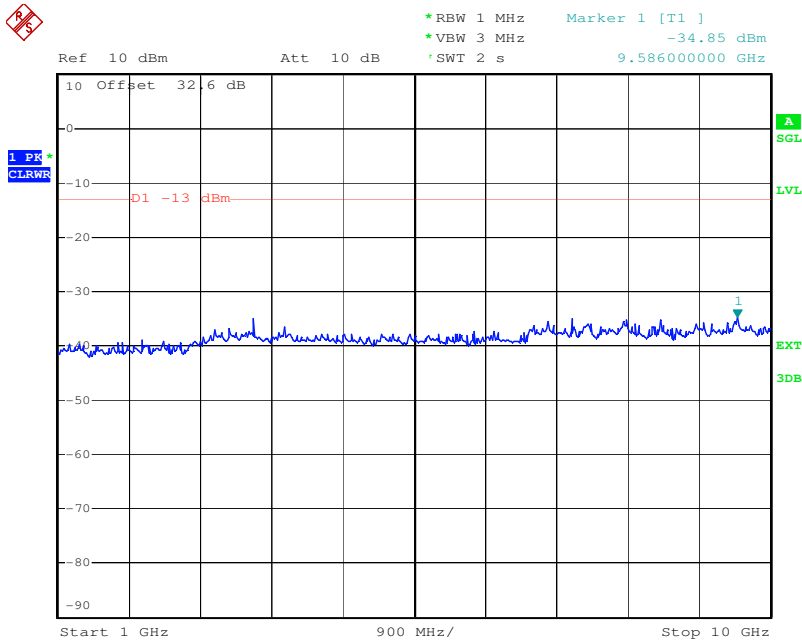

Date: 18.NOV.2009 16:13:53

plot 6.3.1.7-#6 Spurious Emissions at Antenna Terminals: §90.210, §2.1051; Test results; Downlink; Analog > 1MHz to band edge; Top; > 1 GHz



6.3.1.8 FSK > 1MHz to band edge

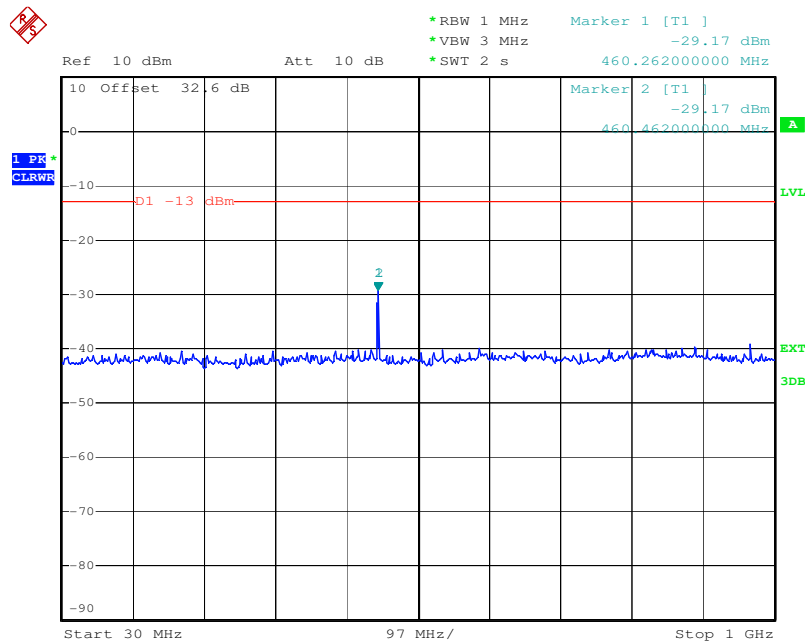

Date: 19.NOV.2009 10:40:39

plot 6.3.1.8-#1 Spurious Emissions at Antenna Terminals: §90.210, §2.1051; Test results; Downlink; FSK > 1MHz to band edge; Bottom; < 1 GHz; Carrier notched

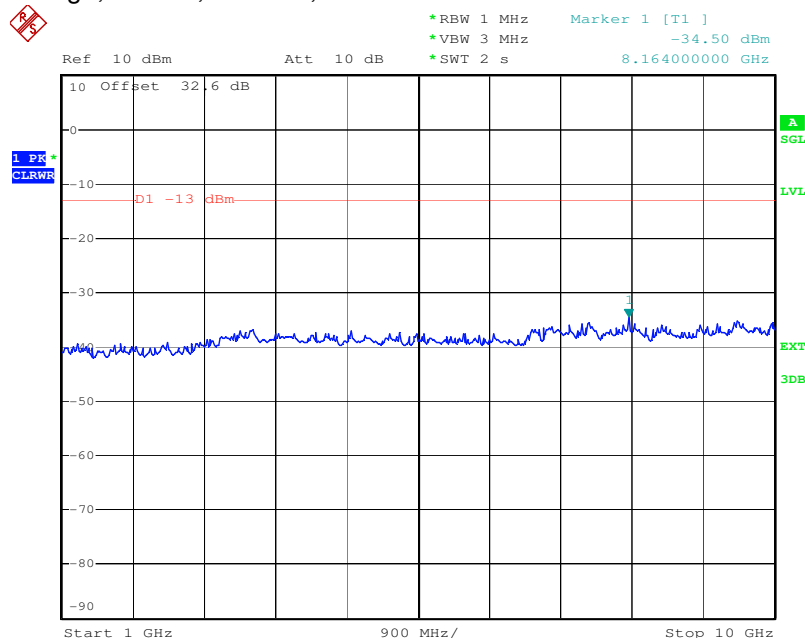

Date: 19.NOV.2009 10:38:29

plot 6.3.1.8-#2 Spurious Emissions at Antenna Terminals: §90.210, §2.1051; Test results; Downlink; FSK > 1MHz to band edge; Bottom; > 1 GHz

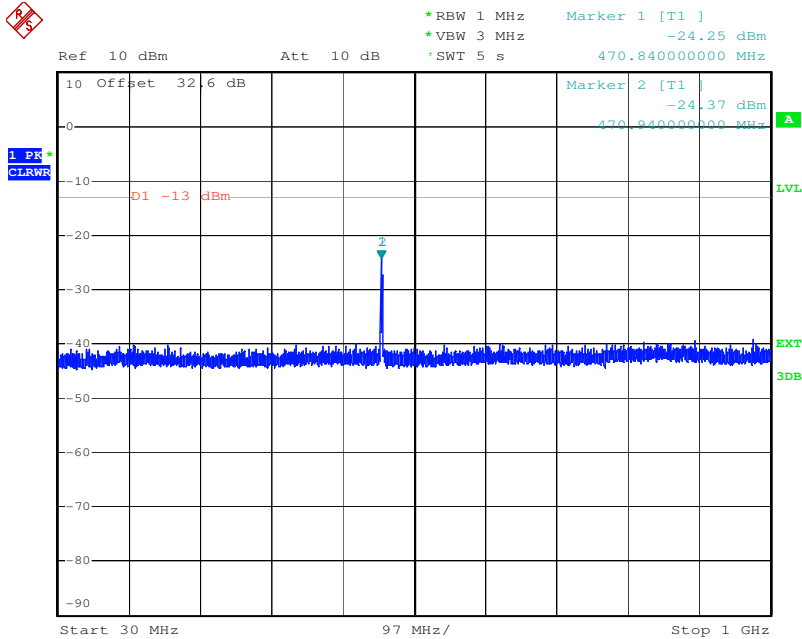

Date: 19.NOV.2009 09:14:46

plot 6.3.1.8-#3 Spurious Emissions at Antenna Terminals: §90.210, §2.1051; Test results; Downlink; FSK > 1MHz to band edge; Bottom; < 1 GHz; Carrier notched

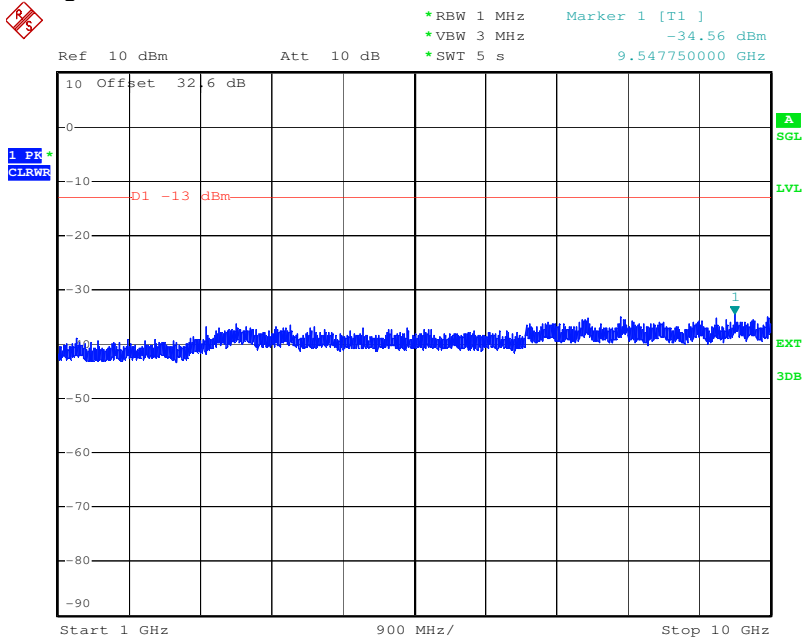

Date: 19.NOV.2009 09:15:50

plot 6.3.1.8-#4 Spurious Emissions at Antenna Terminals: §90.210, §2.1051; Test results; Downlink; FSK > 1MHz to band edge; Bottom; > 1 GHz

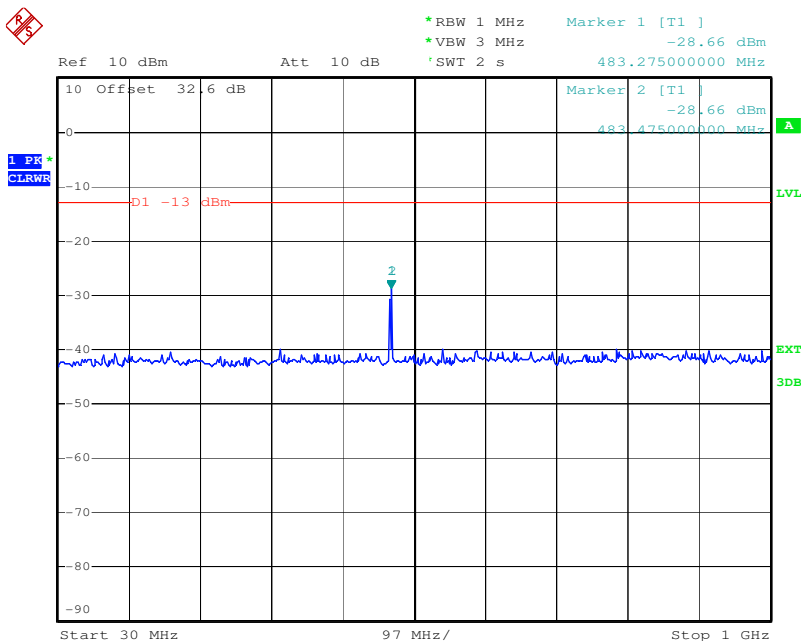

Date: 18.NOV.2009 16:09:40

plot 6.3.1.8-#5 Spurious Emissions at Antenna Terminals: §90.210, §2.1051; Test results; Downlink; FSK > 1MHz to band edge; Top; < 1 GHz; Carrier notched

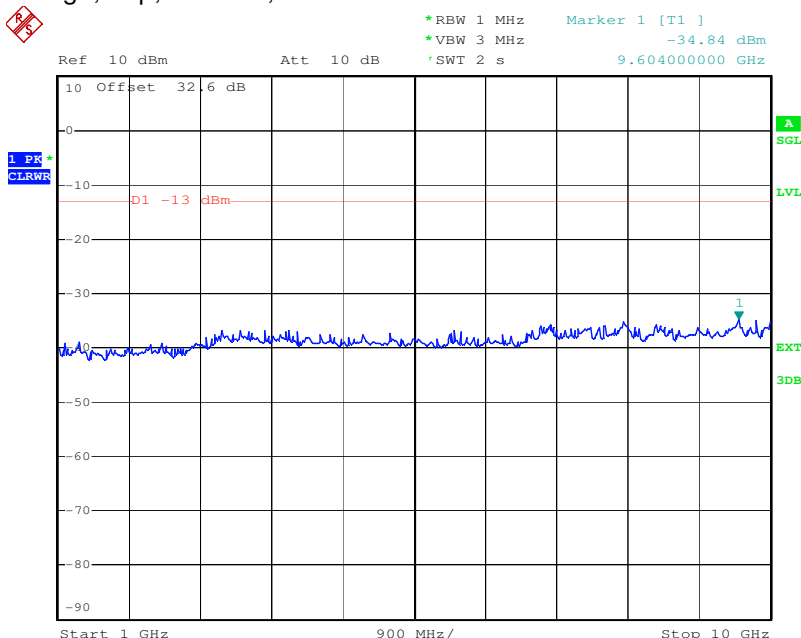

Date: 18.NOV.2009 16:13:28

plot 6.3.1.8-#6 Spurious Emissions at Antenna Terminals: §90.210, §2.1051; Test results; Downlink; FSK > 1MHz to band edge; Top; > 1 GHz



6.3.2 Uplink

n.a.

Note: The EUT does not transmit over the air in the uplink direction.

6.4 Summary test result

Test result	complies, according the plots above
Tested by:	Michael Leinfelder
Date:	18.11.2009

7 Radiated Spurious Emissions at the ECL: §90.210, §2.1053

7.1 Emission Mask Limits

Mask	Spurious Limit
A,B,C,G,H,I	-13dBm
D,J	-20dBm
E,F,K	-25dBm

§ 2.1049 as appropriate. The magnitude of spurious emissions which are attenuated more than 20 dB below the permissible value need not be specified.

7.2 Test method

§ 2.1053 Measurements required: Field strength of spurious radiation .

From KDB (AMPLIFIER, BOOSTER, AND REPEATER REMINDER SHEET):

Radiated spurs (enclosure) – Use of CW signal (low, mid. and high freq.) is acceptable rather than all modulations.

The maximum RFI field strength was determined during the premeasurement by rotating the turntable (± 180 degrees) and varying the height of the receive antenna ($h = 1 \dots 4$ m) as like defined in ANSI C63.4 and TIA-603. The final measurement has been performed by the substitution method as described in ANSI/TIA-603-C-2004 under sec. 2.2.12. A Peak detector has been used.

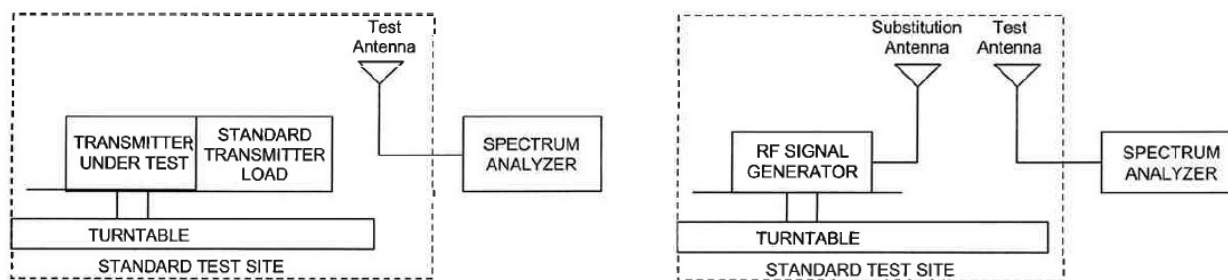

Source: ANSI/TIA 603-C-2004

figure 8-#1 Test setup: Radiated Spurious Emissions at the ECL: §90.210, §2.1053

7.3 Test Results

7.3.1 Spurious emission within the band 30 MHz to 9 GHz.

This clause specifies requirements for the measurement of radiated emission.

Frequency range	Distance: EUT <-> antenna	Limit	Test method	Measurement uncertainty
30 MHz - 1 GHz 1 GHz – 9 GHz	10 metres 3 metres	CFR 47 Part §90.210 -13 dBm	ANSI C63.4 and ANSI TIA-603-C-2004 RBW=100kHz (< 1GHz) RBW=1MHz (>1GHz) Used detector: Peak	Max. 1.64dB

Test equipment used:

designation	Type	manufacurer.	invent.-no.	cal.-date	next cal.-date	used
EMI test receiver	ESI40	Rohde & Schwarz	E1607	04.03.2009	04.03.2010	X
Antenna	CBL 6111	Chase	K1149	14.09.2009	14.09.2010	X
Antenna	CBL 6111	Chase	K1026	14.09.2009	14.09.2010	X
Antenna	HL025	R & S	K809	06.11.2008	06.11.2009	
Antenna	HL025	R & S	K1114	04.06.2009	04.06.2010	X
Antenna	STLP 9148-126	Schwarzbeck	K1759	30.09.2009	30.09.2010	X
Antenna	MWH-1826 / B	ARA Inc.	K1042	06.11.2008	06.11.2010	X
Pre amplifier	AM1431	Miteq	K1721	27.04.2009	27.04.2010	X
Pre amplifier	AFS4-00102000	Miteq	K817	11.11.2009	11.11.2010	X
Pre amplifier	JS43-1800-4000	Miteq	K1104	11.11.2009	11.11.2010	X
RF Cable	RG214	Frankonia	K1121 SET	23.01.2009	23.01.2010	X
RF Cable	Sucoflex 100	Suhner	K1742	09.04.2009	09.04.2010	X

7.3.2 Test data

The spectrum was searched from 30 MHz to the tenth harmonic of the carrier. There were no emissions detected above the noise floor, which was at least 20dB below the specification limit.

24.11.2009

Leh

8 History

Revision	Modification	Date	Name
01.00	Initial release	17.Aug.2009	
02.00	Test done	29.Sept.2009	M. Leinfelder
03.00	Radiated Spurious Emission added	16.Sept. 2009	M. Lehmann
04.00	Adress changed to Nordostpark 51	22. Dec. 2009	M. Lehmann

TAL Test Report No.: 09-195

FCC ID: XS5- IONM4819I



******* End of test report *******