

## General Installation Safety Requirements



Wet conditions increase the potential for receiving an electrical shock when installing or using electrically powered equipment. To prevent electrical shock, never install or use electrical equipment in a wet location or during a lightning storm.



Do not remove protective caps from any of the connectors until instructed to do so.



Due to power dissipation, the Power Supply Units may reach a very high temperature if not properly ventilated. Do not operate this equipment on or close to flammable materials.



Never operate a WCS-2 or WCS-4 Subrack without a Fan Tray installed.



This system is a RF Transmitter and continuously emits RF energy. Maintain a minimum eight-inch (20 cm) clearance from the antenna while the system is operating. Whenever possible, shut down the RAN before servicing the antenna.

## Guard Against Damage from Electro-Static Discharge



Electro-Static Discharge (ESD) can damage electronic components. To prevent ESD damage, always wear an ESD wrist strap when working with hardware components. Not all ERA hardware requires grounding. For those ERA hardware components for which grounding is required, connect the ground wire on the ESD wrist strap to an earth ground source before touching the component. Wear the wrist strap the entire time that you work with the ERA hardware.

## Compliance

- Notice:** For installations, which have to comply with FCC RF exposure requirements, the antenna selection and installation must be completed in a way to ensure compliance with those FCC requirements. Depending on the RF frequency, rated output power, antenna gain, and the loss between the repeater and antenna, the minimum distance D to be maintained between the antenna location and human beings is calculated according to this formula:

$$D_{[cm]} = \sqrt{\frac{P_{[mW]}}{4 * \pi * PD_{[mW/cm^2]}}}$$

where

- P (mW) is the radiated power at the antenna, i.e. the max. rated repeater output power in addition to the antenna gain minus the loss between the repeater and the antenna.
- PD (mW/cm<sup>2</sup>) is the allowed Power Density limit acc. to 47 CFR 1.1310 (B) for general population / uncontrolled exposures which is
  - f (MHz) / 1500 for frequencies from 300MHz to 1500MHz
  - 1 for frequencies from 1500MHz to 100,000MHz

RF exposure compliance may need to be addressed at the time of licensing, as required by the responsible FCC Bureau(s), including antenna co-location requirements of 1.1307(b)(3).

- 2 **Notice:** For installations which have to comply with European EN50385 exposure compliance requirements, the following Power Density limits/guidelines (mW/cm<sup>2</sup>) according to ICNIRP are valid:
- 0.2 for frequencies from 10 MHz to 400 MHz
  - $F \text{ (MHz)} / 2000$  for frequencies from 400 MHz to 2 GHz
  - 1 for frequencies from 2 GHz to 300 GHz
- 3 **Notice:** Installation of this equipment is in full responsibility of the installer, who has also the responsibility, that cables and couplers are calculated into the maximum gain of the antennas, so that this value, which is filed in the FCC Grant and can be requested from the FCC data base, is not exceeded. The industrial boosters are shipped only as a naked booster without any installation devices or antennas as it needs for professional installation.
- 4 **Notice:** For installations which have to comply with FCC/ISED requirements:

**English:**

This device complies with FCC Part 15. Operation is subject to the following two conditions: (1) this device may not cause interference, and (2) this device must accept any interference, including interference that may cause undesired operation of the device.

This device complies with Health Canada's Safety Code. The installer of this device should ensure that RF radiation is not emitted in excess of the Health Canada's requirement. Information can be obtained at [http://www.hc-sc.gc.ca/ewh-semt/pubs/radiation/radio\\_guide-lignes\\_direct-eng.php](http://www.hc-sc.gc.ca/ewh-semt/pubs/radiation/radio_guide-lignes_direct-eng.php).

Changes or modifications not expressly approved by the party responsible for compliance could void the user's authority to operate the equipment.

**Antenna Stmt for ISED:**

This device has been designated to operate with the antennas having a maximum gain of 9 dBi. Antennas having a gain greater than 9 dBi are prohibited for use with this device without consent by ISED regulators. The required antenna impedance is 50 ohms.

The antenna(s) used for this transmitter must be installed to provide a separation distance of at least 100 cm from all persons and must not be co-located or operating in conjunction with any other antenna or transmitter. Users and installers must be provided with antenna installation instructions and transmitter operating conditions for satisfying RF exposure compliance.

**French:**

Cet appareil est conforme à FCC Partie 15. Son utilisation est soumise à Les deux conditions suivantes: (1) cet appareil ne peut pas provoquer d'interférences et (2) cet appareil doit accepter Toute interférence, y compris les interférences qui peuvent causer un mauvais fonctionnement du dispositif.

Cet appareil est conforme avec Santé Canada Code de sécurité 6. Le programme d'installation de cet appareil doit s'assurer que les rayonnements RF n'est pas émis au-delà de l'exigence de Santé Canada. Les informations peuvent être obtenues:

[http://www.hc-sc.gc.ca/ewh-semt/pubs/radiation/radio\\_guide-lignes\\_direct-eng.php](http://www.hc-sc.gc.ca/ewh-semt/pubs/radiation/radio_guide-lignes_direct-eng.php)

Les changements ou modifications non expressément approuvés par la partie responsable de la conformité pourraient annuler l'autorité de l'utilisateur à utiliser cet équipement.

**Antenne Stmt pour ISDE:**

Ce dispositif a été désigné pour fonctionner avec les antennes ayant un gain maximal de 9 dBi. Antennes ayant un gain plus grand que 9 dBi sont interdites pour une utilisation avec cet appareil sans le consentement des organismes de réglementation d'ISDE. L'impédance d'antenne requise est 50 ohms.

L'antenne (s) utilisé pour cet émetteur doit être installé pour fournir une distance de séparation d'au moins 100 cm de toutes les personnes et ne doit pas être co-localisées ou opérant en conjonction avec une autre antenne ou émetteur. Les utilisateurs et les installateurs doivent être fournis avec des instructions d'installation de l'antenne et des conditions de fonctionnement de l'émetteur pour satisfaire la conformité aux expositions RF.

- 5 Notice:** The unit complies with Overvoltage Category II. It also complies with the surge requirement according to EN 61000-4-5 (fine protection); however, installation of an additional medium (via local supply connection) and/or coarse protection (external surge protection) is recommended depending on the individual application in order to avoid damage caused by overcurrent.

For Canada and US, components used to reduce the Overvoltage Category shall comply with the requirements of IEC 61643-series. As an alternative, components used to reduce the Overvoltage Category may comply with ANSI/IEEE C62.11, CSA Certification Notice No. 516, CSA C22.2 No. 1, or UL 1449. Suitability of the component for the application shall be determined for the intended installation.

- 6 Notice:** Corresponding local particularities and regulations must be observed. For national deviations, please refer to the respective documents included in the manual CD that is delivered with the unit.
- 7 Note:** For a Class B digital device or peripheral:

This equipment has been tested and found to comply with the limits for a Class B digital device, pursuant to part 15 of the FCC Rules. These limits are designed to provide reasonable protection against harmful interference in a residential installation. This equipment generates, uses and can radiate radio frequency energy and, if not installed and used in accordance with the instructions, may cause harmful interference to radio communications. However, there is no guarantee that interference will not occur in a particular installation. If this equipment does cause harmful interference to radio or television reception, which can be determined by turning the equipment off and on, the user is encouraged to try to correct the interference.

- 8 Notice:** For a Class A digital device or peripheral.

This equipment has been tested and found to comply with the limits for a Class A digital device, pursuant to Part 15 of the FCC Rules. These limits are designed to provide reasonable protection against harmful interference when the equipment is operated in a commercial environment. This equipment generates, uses, and can radiate radio frequency energy and, if not installed and used in accordance with the instruction manual, may cause harmful interference to radio communications. Operation of this equipment in a residential area is likely to cause harmful interference in which case the user will be required to correct the interference at his own expense.

- 9 Note:** This unit complies with European standard EN60950-1 / EN62368-1.

## Equipment Symbols Used / Compliance

Please observe the meanings of the following symbols used in our equipment and the compliance warnings listed in [Table 10](#).

**Table 10. Compliance Labels**

Symbol	Compliance	Meaning
—	FCC	For industrial (Part 20) signal booster: WARNING: This is NOT a CONSUMER device. It is designed for installation by FCC LICENSEES and QUALIFIED INSTALLERS. You MUST have an FCC LICENSE or express consent of an FCC Licensee to operate this device. Unauthorized use may result in significant forfeiture penalties, including penalties in excess of \$100,000 for each continuing violation.
—	ISED	WARNING: This is NOT a CONSUMER device. It is designed for installation by an installer approved by an ISED licensee. You MUST have an ISED LICENCE or the express consent of an ISED licensee to operate this device. AVERTISSEMENT: Ce produit N'EST PAS un appareil de CONSOMMATION. Il est conçu pour être installé par un installateur approuvé par un titulaire de licence d'ISDE. Pour utiliser cet appareil, vous DEVEZ détenir une LICENCE d'ISDE ou avoir obtenu le consentement exprès d'un titulaire de licence autorisé par ISDE.
CE	CE	To be sold exclusively to mobile operators or authorized installers - no harmonized frequency bands, operation requires license. Intended use: EU and EFTA countries.
		Indicates conformity with the RED directive 2014/53/EU and/or RoHS directive 2011/65/EU.
CE 0700	CE	Indicates conformity with the RED directive 2014/53/EU and RoHS directive 2011/65/EU certified by the notified body no. 0700.

# INSTALL THE SUBRACKS AND PSU IN AN EQUIPMENT RACK

The following sections tell you how to install the following ERA components into an equipment rack:

- WCS-2 Subrack
- WCS-4 Subrack
- Power Supply Unit (PSU) and Rectifier Modules
- e-POI Subrack (optional)

## WCS Subrack Type Considerations

With the introduction of the -48Vdc WCS-2 and -48Vdc WCS-4 subracks, two sets of installation instructions and requirements are now included in the guide to cover both types of WCS subracks. The -48Vdc powered WCS units are well suited for systems where Power over CAT6A is not required, such as WINs, Switching CANS, and TENs that only have Fiber CAPs connected to them. The standard WCS-2 and WCS-4 are still required when PoE is needed for UAPs and Copper CAP Ls.

## Unpack and Inspect the Subracks and Components

- 1 Inspect the exterior of the shipping container(s) for evidence of rough handling that may have damaged the components in the container.
- 2 Unpack each container while carefully checking the contents for damage and verify with the packing slip.
- 3 Do the following if damage is found or parts are missing
  - a Save any damaged cartons for inspection by the carrier.
  - b File a claim with the commercial carrier.
  - c Notify the appropriate support team:
    - For all units except for CDD Cards, notify CommScope Technical Support (see "[CMS Global Technical Support](#)" on page 81).
    - For CDD Cards, contact **Nokia (ALU) support at 1-866-582-3688**.
- 4 Save all shipping containers for use if the equipment requires shipment at a future date.

## Rack-Mount the Subracks and PSU (WCS-2, WCS-4)

When installing ERA Subracks and PSUs, adhere to the rules listed below and as shown in [Figure 7 on page 49](#):



As with any piece of IT equipment, placing the ERA system connection behind a secure firewall is highly recommended.



There must be 1 RU of air space above the PSU.



Support rails are always required for WCS-2 and WCS-4 Subracks and e-POI Subracks. Support rails should never be used for PSU subracks to prevent contact with the DC power terminals on the rear of the units.



Support rails must not block airflow.



Disconnect all input to the PSU before adding it to or removing it from an equipment rack. If you are removing the PSU from an equipment rack, unlatch any installed 12 Vdc or 57 Vdc Rectifier Modules from the PSU chassis before you disconnect the DC Power and Rectifier Control cables on the rear of the chassis.



Connect the PSU to a high leakage current ground (earth) before making any other connections to the PSU.



To maximize airflow through the WCS and e-POI chassis, blank panels must be installed in all empty slots. If additional blank panels are required, contact your local CommScope sales representative to order the appropriate panel:

- Blank Panel Universal (PN 7688866-xx)
- Blank Panel SUI (PN 7688868-xx)
- Blank Panel AUT (PN 7688867-xx)
- e-POI Blank Module (PN 7673474-xx)
- Power Supply Filler Panel (PN 7694140-xx).

The PSU must be installed above the WCS Subrack to support its weight and to ensure that the DC terminals on the rear of the unit do not come into contact with another subrack or other metal surface. There must be 1 RU of air space above the subrack.

[Figure 7 on page 49](#) shows two configurations for mounting Subracks and PSUs in an equipment rack.

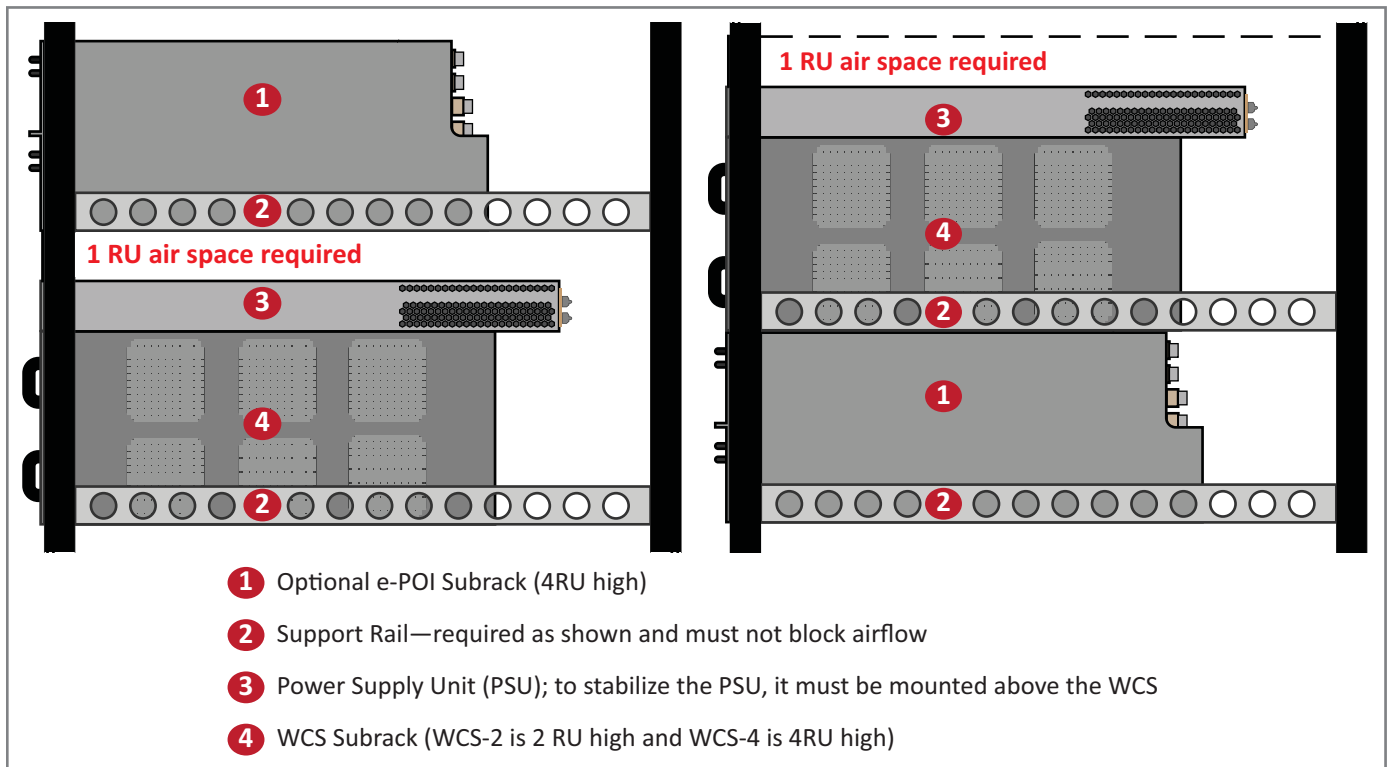

**Figure 7.** WCS Subrack Installation Requirements

Due to the bending radius requirements of the DC Output power cables, a minimum of 23 inches (584 millimeters) of space is required between the front of the PSU subrack and the rear door of the rack or any walls or other obstructions located behind the unit.

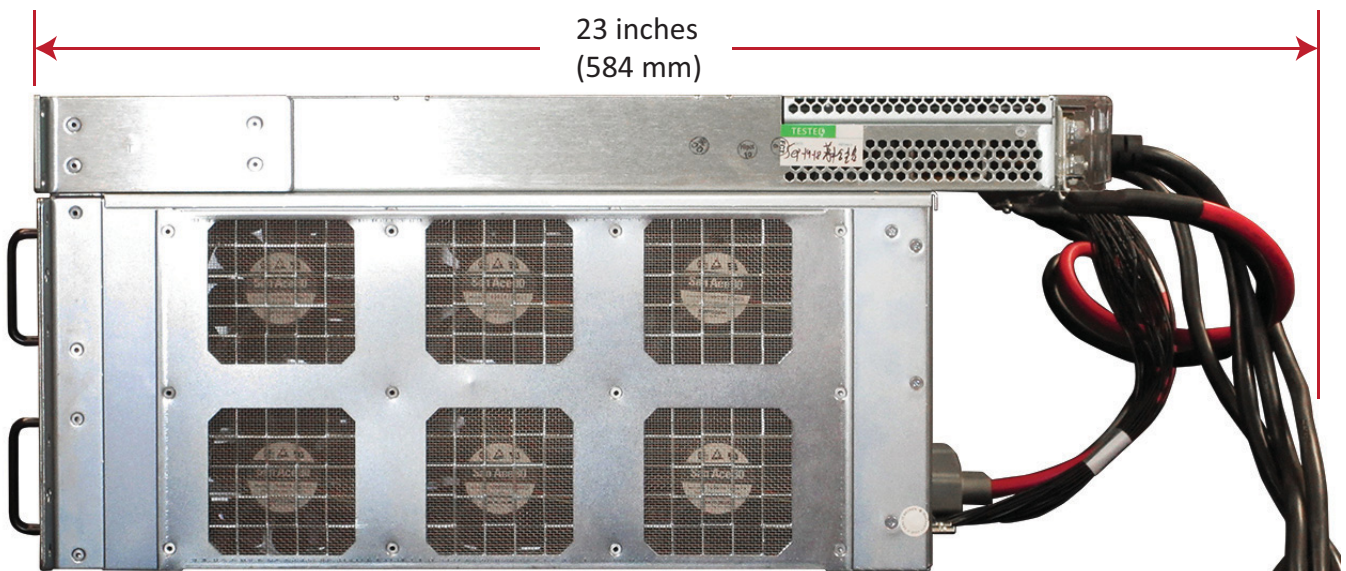

**Figure 8.** Minimum Space Required Behind PSU Subrack



The PSU subrack must be mounted above the WCS subrack to provide support and to prevent the possibility of short circuiting the DC Output terminals. Rack rails should never be used to support the PSU subrack to prevent contact with the DC Output terminals. Avoid contact with the exposed metal on the 12 Vdc and 57 Vdc terminal lugs

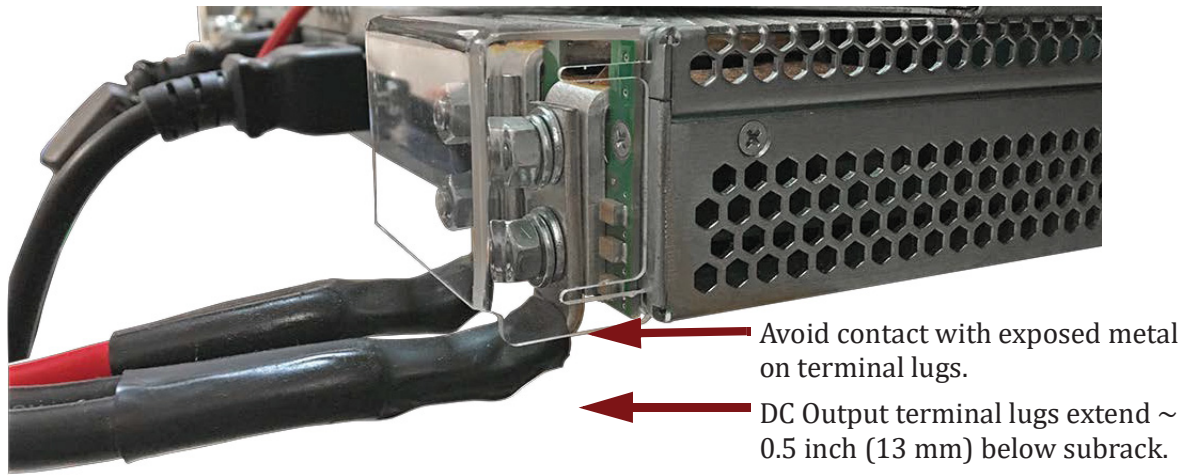

Figure 9. Power Supply Unit DC Output Terminal Lugs

## Connect the WCS Rear-panel Cables

- 1 Connect the rear-panel power, communication, and control cables as shown in the following graphic.

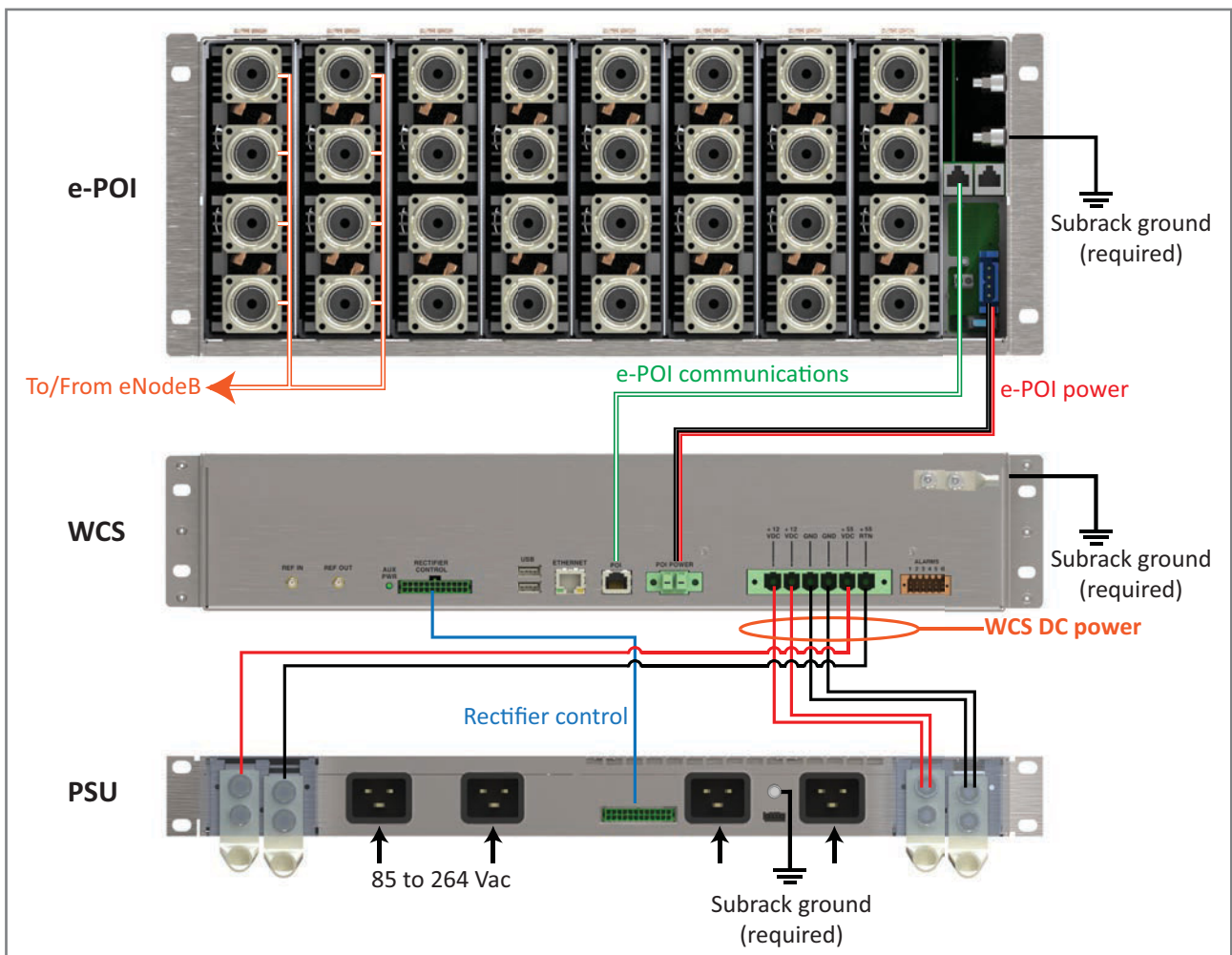
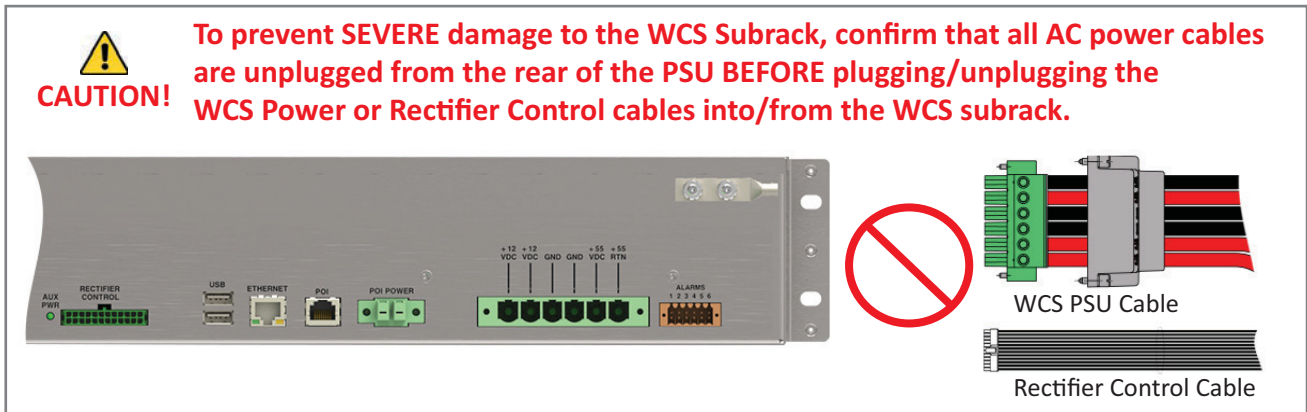

Figure 10. WCS Rear Panel Cabling



- 2 Connect the DC Power cable and the Rectifier Control cables that shipped with the PSU shelf assembly.



- a Do the following before connecting the WCS PSU Cable or the Rectifier Control Cable:
  - Confirm that all AC power cables are unplugged from the rear of the PSU.
  - Remove 12 Vdc Rectifier Modules and 57 Vdc Rectifier Modules from the PSU. Do not skip this step. Residual charge is still available in the Power Modules for a short period after AC input is lost and connecting the WCS PSU Cable or the Rectifier Control Cable with **any** power in the PSU can damage the WCS.
- b Plug the DC Power Cable, which is attached to the rear of the PSU, into the WCS Subrack power connector, and then use a flat-blade screwdriver to tighten the two mounting screws.



To prevent damage to the WCS, tighten the two DC Power Cable mounting screws to ensure that the DC Power Cable cannot be accidentally dislodged.

- c Slide the Power Connector shell over the Subrack power connector and tighten the two thumbscrews to attach it to the WCS Subrack.
- d Plug the Rectifier Control Cable (shown to the right) into the WCS Rectifier Control connector; press it in until you hear it click and lock into place.
- e Plug the other end of the Rectifier Control Cable to the matching connector (unlabeled) on the rear of the PSU.

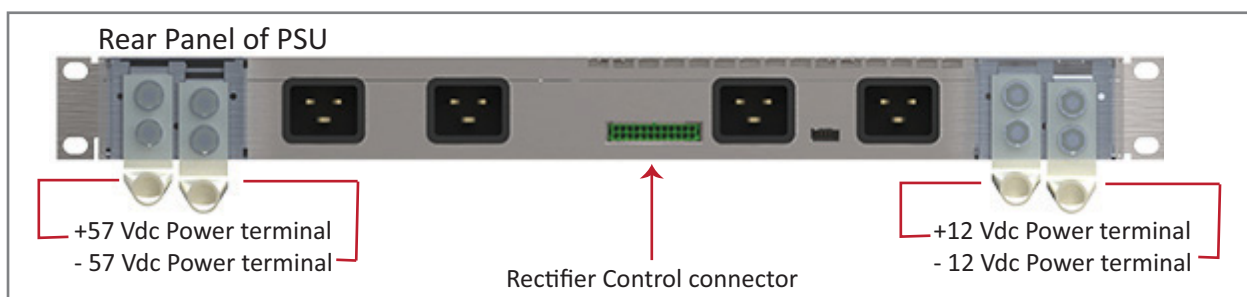

- 3 Connect the Ground stud on the WCS, PSU, and e-POI Subracks to a suitable earth ground, per local and national electrical codes.
- 4 Reseat the 12 Vdc Rectifier Modules and 57 Vdc Rectifier Modules in the PSU.
- 5 Plug AC power cables into the power connectors on the rear of the PSU.

## Rack-Mount the Subracks (-48Vdc WCS-2, WCS-4)

When installing ERA Subracks adhere to the rules listed below:



As with any piece of IT equipment, placing the ERA system connection behind a secure firewall is highly recommended.



Support rails are always required for -48Vdc WCS-2 and WCS-4 Subracks and e-POI Subracks.



Support rails must not block airflow.



To maximize airflow through the WCS and e-POI chassis, blank panels must be installed in all empty slots. If additional blank panels are required, contact your local CommScope sales representative to order the appropriate panel:

- Blank Panel Universal (PN 7688866-xx)
- Blank Panel SUI (PN 7688868-xx)
- Blank Panel AUT (PN 7688867-xx)
- e-POI Blank Module (PN 7673474-xx)
- Power Supply Filler Panel (PN 7694140-xx).

Figure 11 on Page 52 shows two configurations for mounting -48Vdc WCS and e-POI Subracks in an equipment rack.

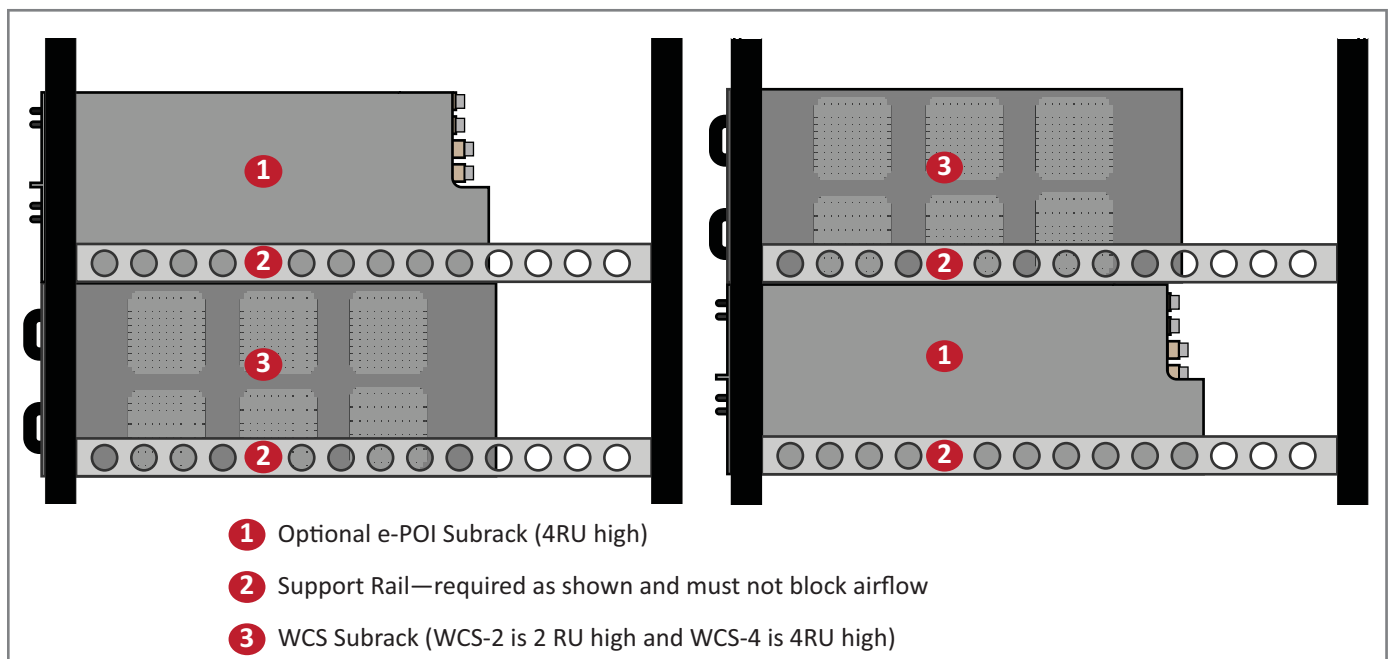

**Figure 11.** -48Vdc WCS Subrack Installation Requirements

## Connect the -48Vdc WCS Rear-panel Cables

- 1 Connect a suitable ground cable from the grounding bolts (studs) to a suitable earth ground, per local and national electrical codes for each of the subracks. Subrack grounding is required.
- 2 Connect the rear-panel power, communication, and power cables as shown in the following graphic.

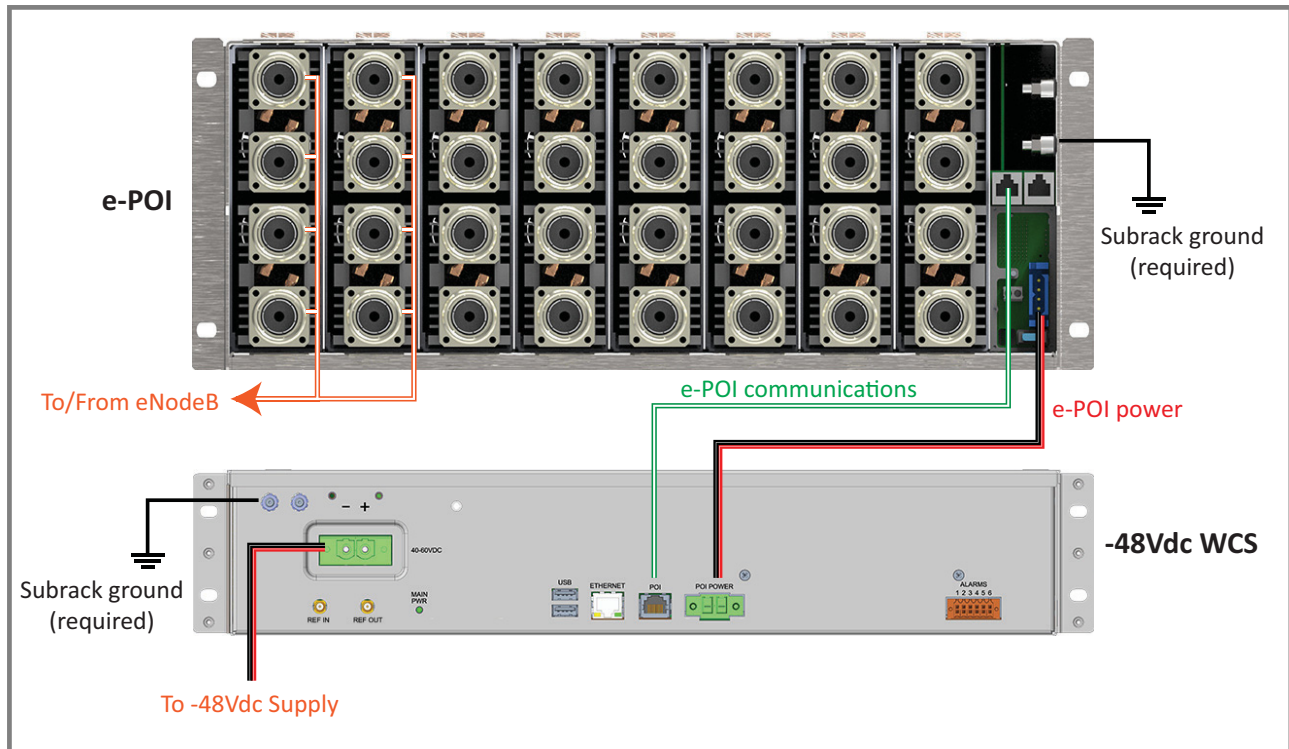
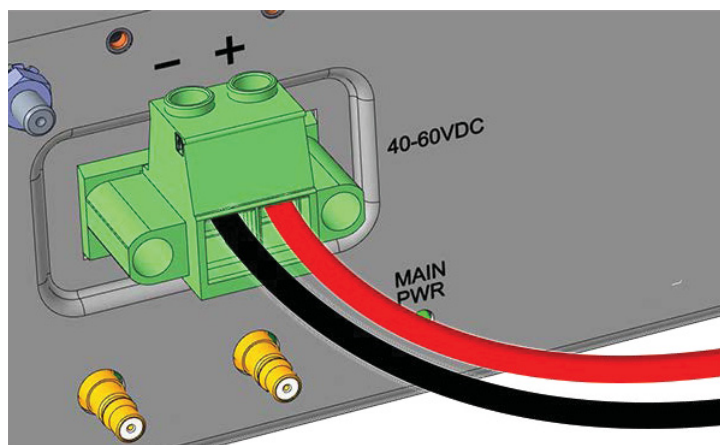

Figure 12. -48Vdc WCS Rear Panel Cabling

- 3 Connect the cables from the -48Vdc power supply to the two-conductor DC power entry connector that shipped with the -48Vdc WCS subrack (observing the correct polarity.) and plug it into the WCS subrack. As in all standard -48Vdc power systems, the Red wire that is connected to the '+' terminal of the WCS DC power entry plug will also be connected to earth ground back at the -48Vdc power source. Please see the 48Vdc WCS DC Power Supply Requirements in Table 11 on the next page.



The -48Vdc DC power entry connector is hot plug/unplug tolerant and has reverse polarity protection.

- 4 Connect the e-POI communications and power cables from the WCS to the e-POI subrack (if used).

**Table 11.** -48Vdc WCS DC Power Supply Requirements

DC Power Supply Requirements	
Input Voltage Range	-40 Vdc to -60 Vdc
Current -48Vdc WCS-4	20A maximum
Current -48Vdc WCS-2	15A maximum
-48Vdc WCS-4 Max Load	691 Watts
-48Vdc WCS-2 Max Load	418 Watts
-48Vdc WCS-2 Max Load (TEN Configuration)	115 Watts

# INSTALL AND CONNECT THE SUBRACK CARDS

The following sections tell you how to install a card into a WCS Subrack, add SPF+ transceivers to an OPT Card, and how to connect the Subrack cards to the ERA system.



This installation guide tells you how to install all the WCS Subrack card types except for the CDD Card. For information on how to install a CDD Card, refer to the *CPRI Digital Donor Card Installation and Configuration Guide*; see "[Accessing ERA Series User Documentation](#)" on page 82.

## Install a Subrack Card

Do the following to install an ERA card into a WCS-2 or WCS-4 Subrack.

- 1 Observe all cautions in "[Safely Working with ERA Hardware](#)" on page 42.
- 2 Follow the rules listed in "[WCS Subrack Slot and Card Assignments](#)" on page 17 to identify in which slot(s) a card to install in a WCS-2 or WCS-4 Subrack to configure the Subrack as a Classic CAN, Switching CAN, WIN, or TEN.
- 3 CDD Cards and RFD Cards should be populated in the Subrack from bottom to top starting with the bottom slot of each section of the Subrack (Slot R1 or Slot R5) to ensure optimal cooling of the cards. For example, if you have only one CDD Card, it should be installed in Slot R1 and blank panels should be installed in R2-R4.
- 4 Remove the blank panel from the slot in which a card is to be installed.
  - a Loosen the silver PEM screw on the left that secures the blank panel to the Subrack.
  - b Reserve the blank panel for future use.
- 5 Install the card in the Subrack.
  - a Use the black Support knob on the right of the card's faceplate to slide the card into its slot, and then push the card into its slot back until the card's faceplate is flush against the Subrack chassis.



**When installing a Card into or removing it from a Subrack, keep the Card level. Tipping the Card up or down during installation or extraction may cause it to strike another component in the Subrack, which can damage the Card and/or the component that was struck.**

- b Tighten the silver PEM screw on the left of the card's faceplate to secure the card to the Subrack chassis.

The following graphic shows the PEM screw and support knob on a CDD Card. Although other cards will have different connectors and LEDs, the positioning of the PEM screw and Support knob will be the same.

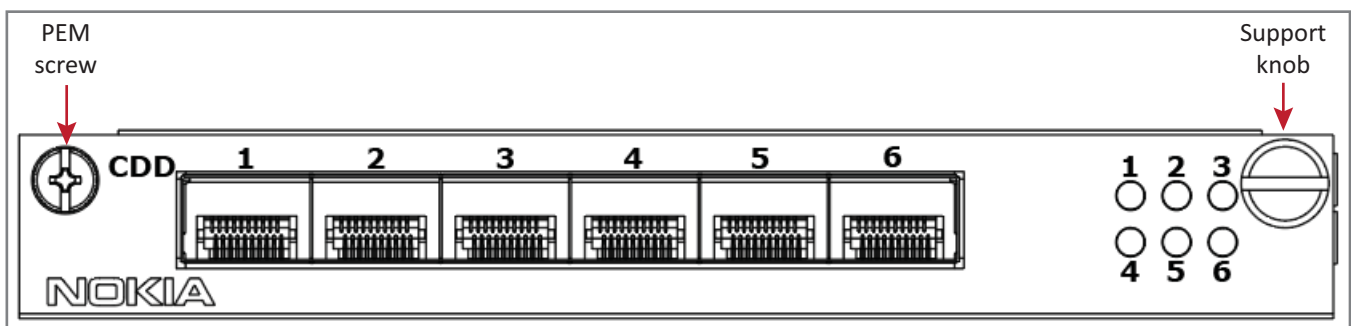

- c Do not leave any unoccupied slots open; replace blank panels, as necessary.



To maximize airflow through the WCS and e-POI chassis, blank panels must be installed in all empty slots. If additional blank panels are required, contact your local CommScope sales representative to order the appropriate panel:

- ERA Blank Panel Universal (PN 7688866-xx)
- ERA Blank Panel SUI (PN 7688868-xx)
- ERA Blank Panel AUT (PN 7688867-xx).



CDD Cards and RFD Cards should be populated in the Subrack from bottom to top starting with the bottom slot of each section of the Subrack (Slot R1 or Slot R5) to ensure optimal airflow to the cards.

## Connect the SUI Card

The SUI Card allows you to connect the WCS Subrack to a local laptop, LAN, or modem. Connect any of these devices as required for local practice.

- **Local:** Use Ethernet CAT 5 cable (straight or crossover) with RJ-45 connectors to connect a local laptop or PC to the Local port to allow for administration of the ERA system through the ERA software.
- **LAN2:** Use Ethernet CAT 5 cable (straight or crossover) with RJ-45 connectors to connect your LAN or a modem to the LAN2 port.

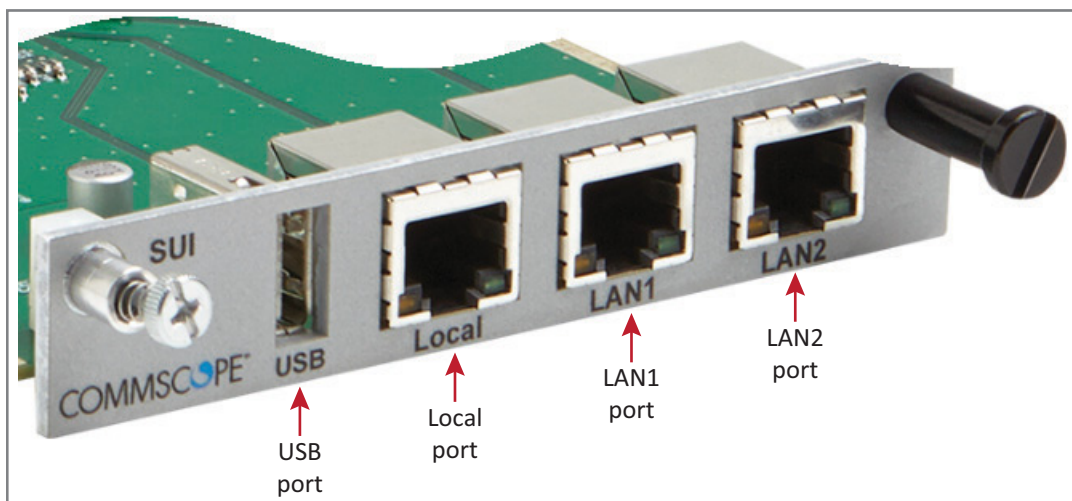

The LAN1 port is not currently used.

The USB port is reserved for use by CommScope.



SUI Cards are hot swappable; you do not need to power down the CAN, TEN, or WIN to install or remove an SUI Card.

## Connect the RFD Cards



Classic CANs and WINs support RFD Cards, however, TENs and Switching CANs do not support RFD Cards.



CAP M and CAP H APs require the use of RFD Card PN 7633229-01, 7633229-02, or higher.



RFD Cards are hot swappable; you do not need to power down the CAN or WIN to install or remove an RFD Card.

- 1 Connect RF cables from the BTS/eNodeB or e-POI to the QMA connectors of the RFD cards.
  - SISO services such as CDMA, UMTS, GSM, and LTE SISO can be connected to any active port.
  - Simplex port connections typically can use any two ports on the same RFD Card, except for LTE MIMO 2x2 pairs.

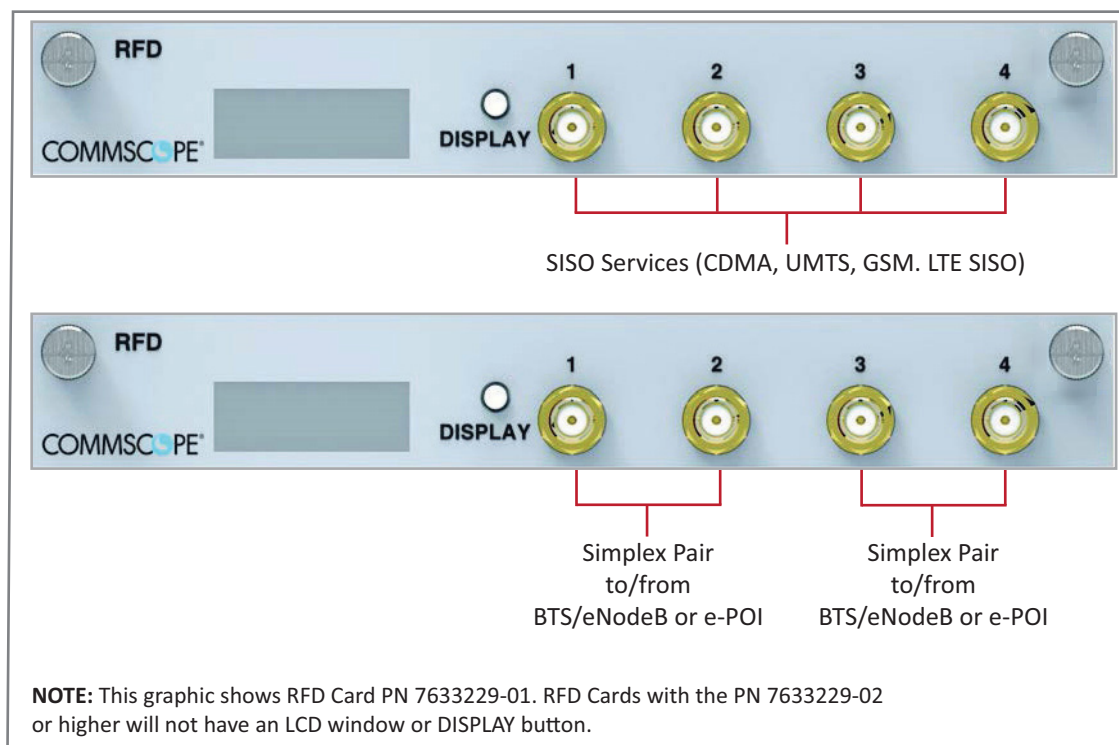

- Simplex ports supporting LTE MIMO 2x2 must be configured as follows: pair Port 1 DL with Port 3 UL, and pair Port 2 DL with Port 4 UL on the same RFD Card.
- Duplex ports supporting LTE MIMO 2x2 pairs must be connected to the same RFD Card, as a pair to: Port 1 and Port 2 or to Port 3 and Port 4.
- LTE MIMO 4x4 requires that all four paths (MIMO index AP0, AP1, AP2, and AP3) of an eNodeB be connected to duplex ports on the same RFD card. No duplicates of the MIMO index and no missing MIMO indexes are allowed. No specific MIMO index connection order is required. Simplex connections are not supported.

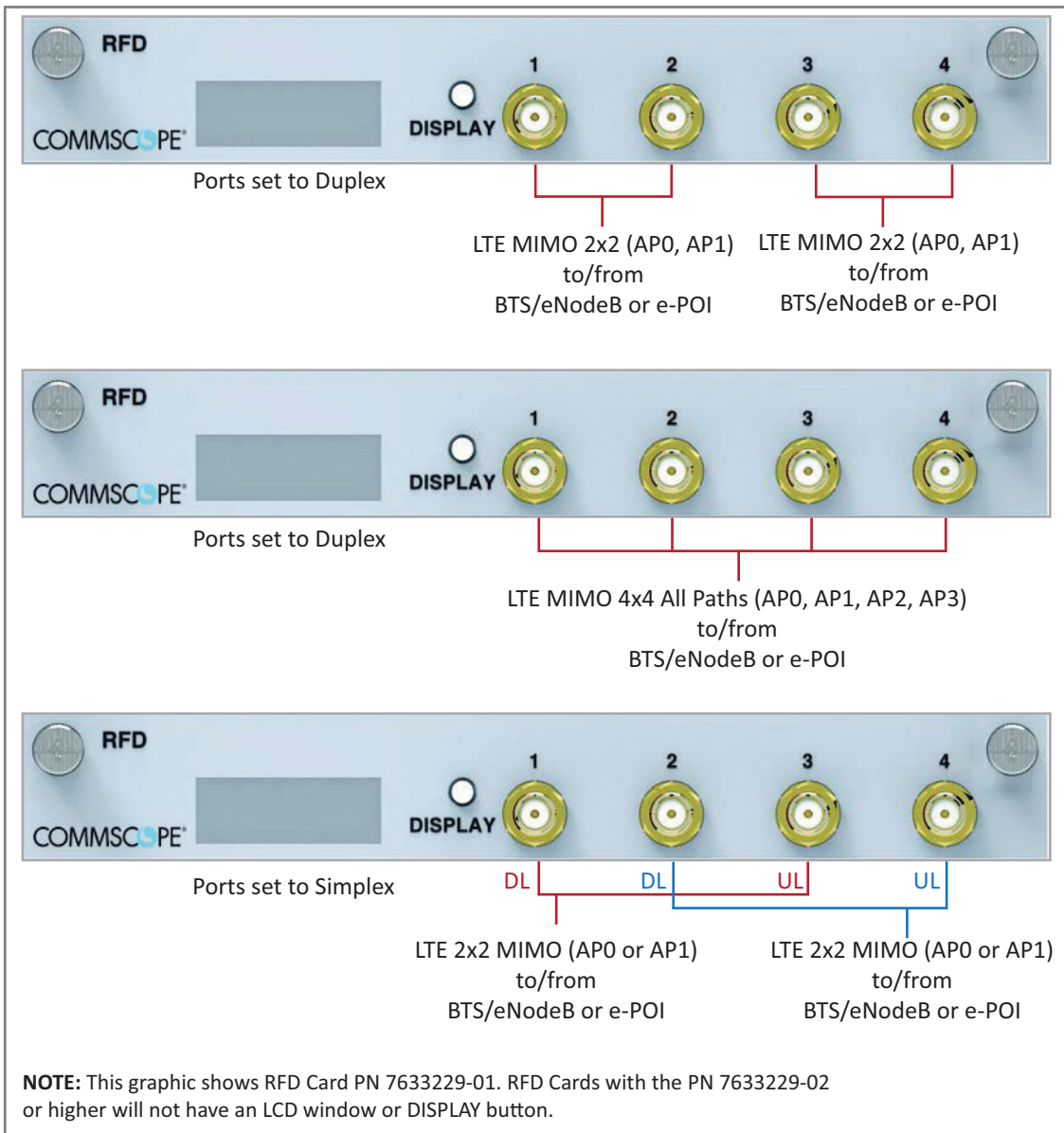

- 2 If the signal levels of the BTS exceed the maximum input level of + 16 dBm, an e-POI Module or other suitable attenuator must be used to attenuate the signal. For optimum PIM performance, the composite level into a Donor (RFD Card) port should be less than 16 dBm. If only one carrier is in a band, PIM is probably not a concern. For the case of two or more carriers in a band, spurious intermods due to PIM could land in the UL causing interference. Whether or not PIM will cause interference depends on the spacing between UL and DL and the frequencies of active carriers.



## Connect the OPT Cards

OPT cards provide a 10 Gbps fiber connection between CANs, TENS, and WINs; and between CANs and TENS and Fiber APs. Each OPT Card supports up to four SFP+ transceivers for device connections.



**OPT Cards are hot swappable; you do not need to power down the CAN, TEN, or WIN to install or remove an OPT.**

Connecting OPT Cards is a two-phase process:

- In phase 1, you "[Install SFP+ Modules in the OPT Cards](#)" on page 61.
- In phase 2, you connect the OPT Card to another WCS Subrack or to a Fiber AP, as required for this installation:
  - "[Cabling OPT Cards to Connect a WIN a Switching CAN](#)" on page 63
  - "[Cabling OPT Cards to Connect the TEN to a Classic CAN](#)" on page 65
  - "[Cabling OPT Cards to Connect a TEN to a Switching CAN](#)" on page 67
  - "[Cabling OPT Cards for Connecting to a Fiber AP](#)" on page 69.

## Fiber Optic Link Budget in the ERA System

When designing the fiber links for the CommScope ERA system, is important to consider all the factors that can affect link performance. These factors include TX optical power, RX sensitivity, the fiber length, the wavelength, the number of splices, and the number of connectors. This topic briefly describes the key factors that should be considered.

### Minimum Optical Path Loss

The optical power applied to the RX input of the SFP+ module must be less than the Receiver Overload threshold. In some cases, the Receiver Overload is less than or equal to the maximum TX Optical Power, which allows a very short fiber jumper to be used to connect TX to RX power; however, in other cases the TX Power exceeds the Receiver Overload threshold, so a minimum amount of optical attenuation must be applied between the TX output and RX input to prevent overdriving the RX input. See [Table 14 on page 61](#) for a list of SFP+ modules that are qualified for use with the ERA system.

$$\text{Optical Fiber Path Loss} \geq \text{TX Optical Power Max} - \text{Receiver Overload}$$

If the path loss is below the amount of attenuation needed to prevent exceeding the Receiver Overload threshold, then additional attenuation must be added in the link to prevent overdrive. This can be done by adding additional fiber or by using an inline optical attenuator.

### Maximum Optical Path Loss

The optical power received at the RX input must be greater than the RX Sensitivity. The RX power is equal to the minimum TX power reduced by any optical attenuation in the TX-RX path. It is good design practice to provide additional link margin when designing the fiber links.

$$\text{Maximum Optical Path Loss} \leq \text{TX Optical Power Min} - \text{RX Sensitivity} - \text{Link Margin}$$

## Optical Link Loss

Optical loss is calculated by adding the attenuation due to the length of the fiber optic cable, the number of connectors in the link, and the number of splices. If there are other optical devices in the link, then their attenuation needs to be included as well (mux, demux, add/drop, etc.).

$$\begin{aligned} \text{Optical Link Loss} &= \text{fiber length(km)} * \text{optical attenuation/km} \\ &+ \text{Splice Loss} * \text{Number of splices} \\ &+ \text{Connector Loss} * \text{Number of Connectors} \end{aligned}$$

## Minimum Performance Levels

The values below are the minimum performance specifications for fiber optic components noted in ANSI/TIA/EIA-568-C.3 Optical Fiber Cabling Components, with key performance specifications shown in Table 12 and Table 13 below.

**Table 12.** Minimum Performance of Optical Components

Parameter	Minimum Performance <sup>1</sup>
Mated connector pair	0.75 dB
Splice	0.3 dB
1 Actual performance may be better than the minimum performance values noted.	

**Table 13.** 10 Gbps Ethernet Standards for Optical Link Budget

SFP+ Module Type	10GBASE-SR		10GBASE-LR	10GBASE-ER
	OM3	OM4	G.652	G.652
Maximum Distance (m)	300	400	10,000 <sup>1</sup>	40,000 <sup>1</sup>
Wavelength of Operation (nm)	850	850	1310	1550
Loss per km @ wavelength (dB)	3.5	3.5	0.5	0.5
Allowed Measured Loss (dB)	2.6	2.9	6.0	11.0
Allowed Back Reflection (dB)	-20	-20	-26	-26
1 Maximum Distance may require < 0.5dB/km loss. Most high quality single mode cables are so rated.				

## SFP+ Modules Tested for use with ERA

The following SFP+ modules are available from CommScope. These SFP+ modules have been tested by CommScope to ensure that they meet the requirements of an ERA system. This list was current at the time that this manual was published but is subject to change.

**Table 14.** SFP+ Modules Tested for Use with ERA

CommScope Part No.	Description	Minimum Path Loss	CommScope Part No.	Description	Minimum Path Loss
7660511	SFP+, 10GBase-SR, (MM)	0 dBm	7803295	IC SFP+ APSPC35B33CDL40 Transceiver	5 dBm
7680813	SPF+, LR (SM)	0 dBm	7803298	IC SFP+ APSPC37B33CDL40 Transceiver	5 dBm
7801330	SFP+ CWDM 1471 nm, 10G-BASE-ER/EW, 10GbE	5 dBm	7803900	IC SFP+ APSPC39B33CDL40 Transceiver	5 dBm
7801340	SFP+ CWDM 1491 nm, 10G-BASE-ER/EW, 10GbE	5 dBm	7803902	IC SFP+ APSPC41B33CDL40 Transceiver	5 dBm
7801342	SFP+ CWDM 1511 nm, 10G-BASE-ER/EW, 10GbE	5 dBm	7803904	IC SFP+ APSPC43B33CDL40 Transceiver	5 dBm
7801344	SFP+ CWDM 1531 nm, 10G-BASE-ER/EW, 10GbE	5 dBm	7803906	IC SFP+ APSPC45B33CDL40 Transceiver	5 dBm
7801360	SFP+ CWDM 1551 nm, 10G-BASE-ER/EW, 10GbE	5 dBm	7832204	10G BIDI SFP+ TX1270/RX1330 40km I-temp	5.5 dBm
7801363	SFP+ CWDM 1571 nm, 10G-BASE-ER/EW, 10GbE	5 dBm	7832206	10G BIDI SFP+ TX1330/RX1270 40km I-temp	5.5 dBm
7801365	SFP+ CWDM 1591 nm, 10G-BASE-ER/EW, 10GbE	5 dBm	7843514	SFP+, LC, 1310nm, max. 40Km	5.5 dBm
7801367	SFP+ CWDM 1611 nm, 10G-BASE-ER/EW, 10GbE	5 dBm	7845626	10G BIDI SFP+ TX1310/RX1270 20km I-temp	2.5 dBm
7803247	IC SFP+ APSPC27B33CDL40 Transceiver	5 dBm	7845627	10G BIDI SFP+ TX1270/RX1310 20km I-temp	2.5 dBm
7803249	IC SFP+ APSPC29B33CDL40 Transceiver	5 dBm	7845628	CSFP BIDI Transceiver Tx-1270 / Rx-1310 (20km)	2.5 dBm
7803291	IC SFP+ APSPC31B33CDL40 Transceiver	5 dBm	7845629	CSFP BIDI Transceiver Tx-1310 / Rx-1270 (20km)	2.5 dBm
7803293	IC SFP+ APSPC33B33CDL40 Transceiver	5 dBm			

## Install SFP+ Modules in the OPT Cards

The following steps tell you how to install the appropriate 10 Gbps SFP+ Module into the ports on the OPT Card that will be used to provide a 10 Gbps fiber connection between a CAN and a TEN or a WIN, or between a CAN or TEN and a Fiber AP.

- 1 The SFP+ Module used must match the type of fiber used—Multi-Mode Fiber or Single-Mode Fiber (SMF or MMF). If necessary, contact your local CommScope sales representative to obtain the required number of SFP+ Modules for this installation.

CommScope recommends testing with a device capable of certifying the end-to-end link (including the SFP+ Module) to ensure the installation meets the applicable 10Gbps Ethernet standard.

- 2 If the optical fiber path loss is below the minimum amount needed to prevent overdrive of the receiver, then insert an in-line optical attenuator to increase the loss above the minimum threshold.

- 3 Follow the steps in "Install and Connect the Subrack Cards" on page 55 to install the OPT Card into the WCS Subrack, as needed for this installation:
  - For a Classic CAN, you use:
    - Slots L1 - L4 for an OPT Card connecting a Classic CAN to a TEN or a Fiber AP
    - Slots L1 - L8 for an OPT Card connecting the Classic CAN to a TEN.
  - For a Switching CAN, you use:
    - Slots L1 - L8 for an OPT Card connecting a Switching CAN to a TEN
    - Slots R1 - R8 for an OPT Card connecting a Switching CAN to a WIN.
  - For WINs, you use:
    - Use Port L1.1 to connect to the Switching CAN.
    - Use Ports L1.2 through L2.4 for additional WIN-to-CAN links to increase the WIN bandwidth to support multiple operators and sectors.
  - For TENs, you use:
    - Slot R1, Port 1 (**R1.1**) to connect to a Classic or Switching CAN. **R1.1** is the primary control slot and is mandatory.
    - Slot R1, Ports 2 - 4 (**R1.2 - R1.4**) for additional TEN-to-CAN links.
    - L1 - L4 to connect to a Fiber AP over an optical-fiber link.
- 4 Use the system design to identify which OPT Card ports will be used in this system.
- 5 Slide the SFP+ into the OPT Card port identified in Step 4, and push the SFP+ into the OPT Card until you hear it click into place.

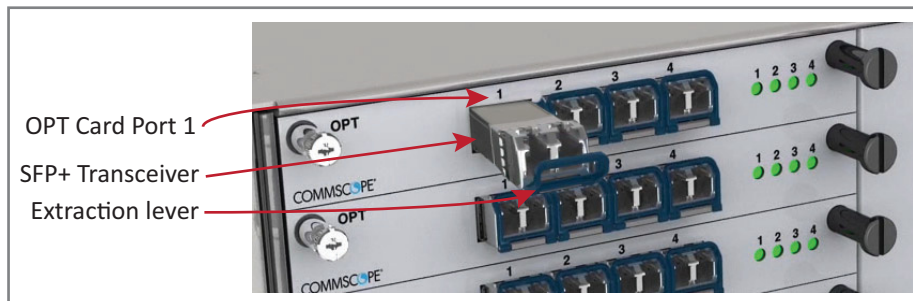

Should you need to remove an SFP+ Module, do the following in the order presented to prevent damage to the SFP+ Module, the OPT Card, or the fiber.

- 1 Disconnect the fiber cable.
- 2 Pull the extraction lever on the SFP+ Module towards you. Do not rotate the lever downward more than 90 degrees to avoid damage to the lever.
- 3 Use the extraction lever to carefully pull the SFP+ module out of the OPT Card slot.

## Cabling OPT Cards to Connect a WIN a Switching CAN

In this process you will connect SFP+ Modules to the fiber cable and then use the cable to connect a WIN to a Switching CAN.



The graphics used in this process show a WCS-4 Subrack as a Switching CAN, and a WCS-2 Subrack as a WIN. The same rules for slots and port connections apply if the Switching CAN was a WCS-2 Subrack or the WIN was a WCS-4 Subrack.

- 1 Complete the steps in "SFP+ Modules Tested for use with ERA" on page 61.
- 2 Obtain a pair of SFP+ Modules that correspond to the length and type of fiber you will use to connect the CAN to the WIN. Note the maximum range listed in Table 13 on page 60.
- 3 Follow local practice or manufacturer recommendations to clean fiber connectors.
- 4 Connect one end of the cable with an SFP+ Module into one of the OPT Card ports (labeled 1 - 4) installed in the Switching CAN—you can only use Slots **R1** - **R8** in the Switching CAN.
- 5 Connect the other end of the cable with an SFP+ Module into **Port 1** on the OPT Card installed in **Slot L1** (L1.1) of the WIN.

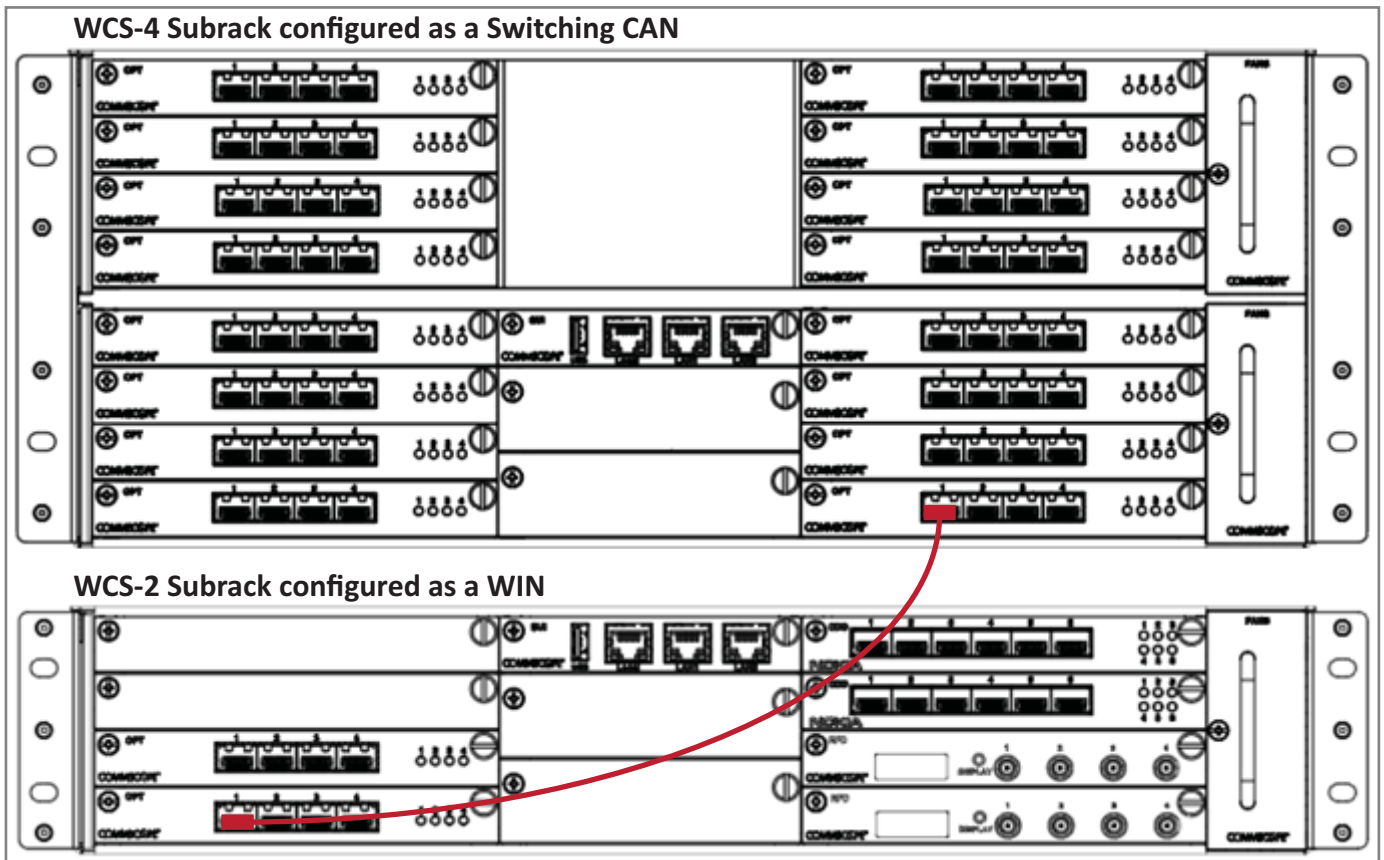

- 6 (Optional). Do the following to add an additional WIN-to-CAN link to increase the WIN bandwidth to support additional operators and sectors:
  - a Obtain a pair of SFP+ Modules that correspond to the length and type of fiber you will use to connect the Switching CAN to the WIN. Note the maximum range listed in [Table 13 on page 60](#).
  - b Follow local practice or manufacturer recommendations to clean fiber connectors.
  - c Connect one end of the cable with an SFP+ Module into one of the four ports on the OPT Card (labeled 1 - 4) installed in the Switching CAN.
  - d Connect the other end of the cable with an SFP+ Module into **Port 2** on the OPT Card installed in **Slot L1** of the WIN.

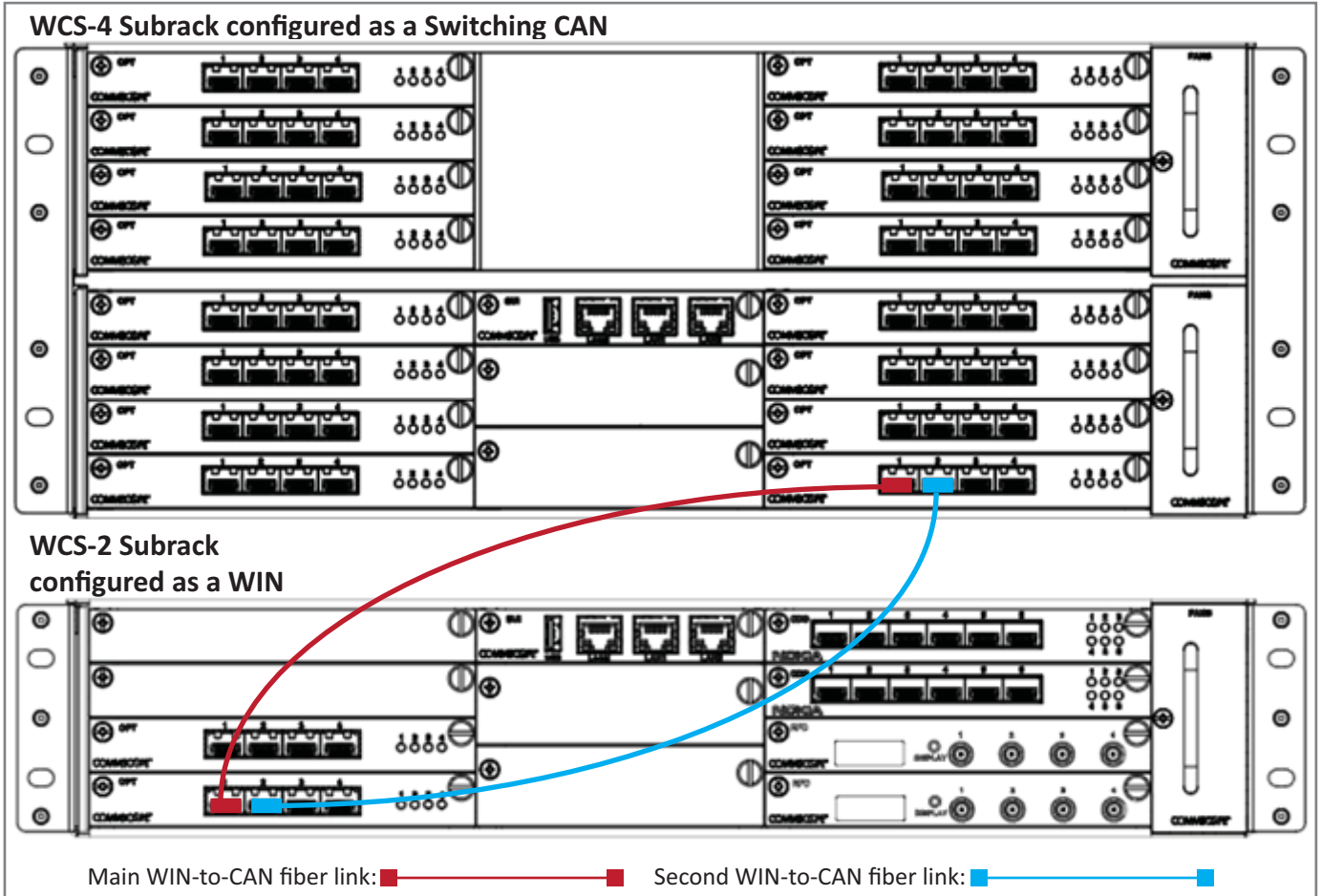

- 7 (Optional). To add additional WIN-to-CAN links to increase the WIN bandwidth to support additional operators and sectors, follow the process in [Step 6](#), as needed for each additional link.



In addition to the card placement, you must also configure the function of the WCS Subracks in the ERA GUI. For further information, refer to the ERA configuration guide for Software Version 2.5 or later; see ["Accessing ERA Series User Documentation"](#) on page 82.

## Cabling OPT Cards to Connect the TEN to a Classic CAN

In this process you will connect SFP+ Modules to the fiber cable and then use the cable to connect the TEN to a Classic CAN.



The graphics used in this process show a WCS-4 Subrack as a Classic CAN, and a WCS-2 Subrack as a TEN. The same rules for slots and port connections apply if the Classic CAN was a WCS-2 Subrack or the TEN was a WCS-4 Subrack.

- 1 Complete the steps in "SFP+ Modules Tested for use with ERA" on page 61.
- 2 Obtain a pair of SFP+ Modules that correspond to the length and type of fiber you will use to connect the CAN to the TEN. Note the maximum range listed in Table 13 on page 60.
- 3 Follow local practice or manufacturer recommendations to clean fiber connectors.
- 4 Connect one end of the cable with an SFP+ Module into one of the OPT Card ports (labeled 1 - 4) installed in the CAN.
- 5 Connect the other end of the cable with an SFP+ Module into **Port 1** on the OPT Card installed in **Slot R1** of the TEN.

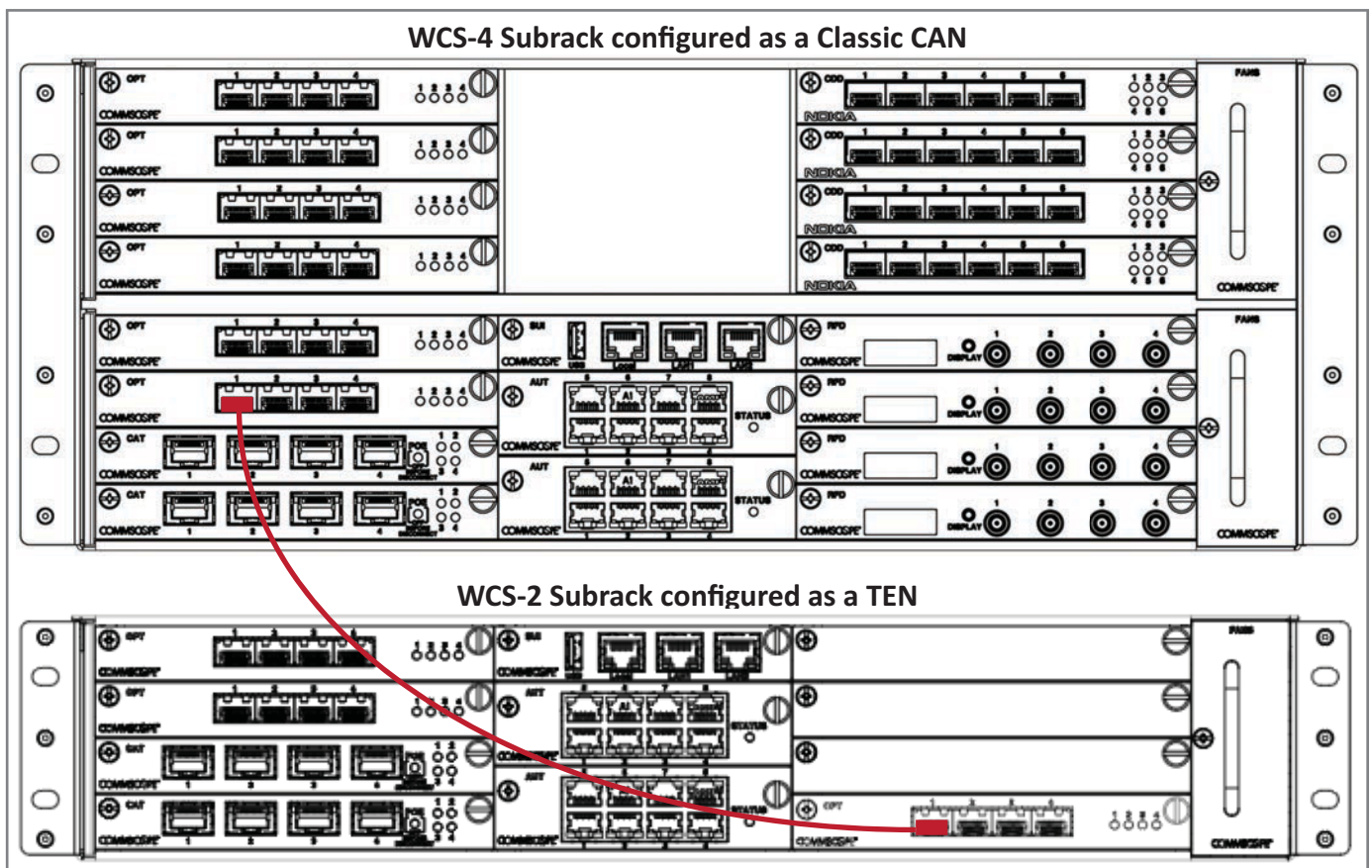

- 6 (Optional). To add an additional 320 MHz of RF between the TEN and CAN, do the following:
  - a Obtain a pair of SFP+ Modules that correspond to the length and type of fiber you will use to connect the CAN to the TEN. Note the maximum range listed in [Table 13 on page 60](#).
  - b Follow local practice or manufacturer recommendations to clean fiber connectors.
  - c Connect one end of the cable with an SFP+ Module into one of the four ports on the OPT Card (labeled 1 - 4) installed in the CAN.
  - d Connect the other end of the cable with an SFP+ Module into **Port 2** on the OPT Card installed in **Slot R1** of the TEN.

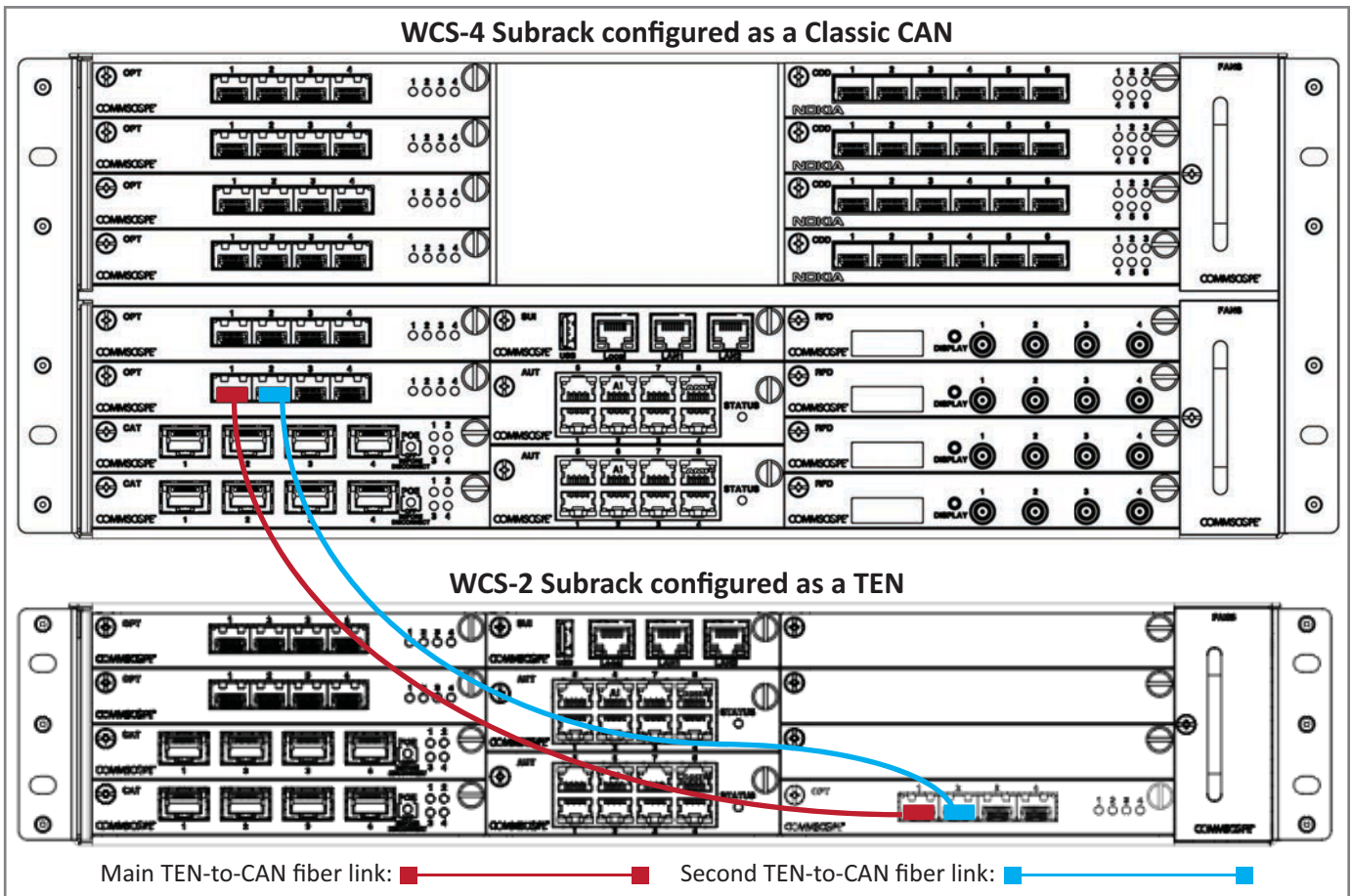

- 7 (Optional). To add additional TEN-to-CAN links, with each link adding an additional 320 MHz of RF capacity between the TEN and CAN, follow the process in [Step 6](#), as needed for each additional link. However, you will now use Ports R1.2 through R1.4, which must be populated consecutively—there cannot be unused ports between used ports. That is, you cannot use Port R1.2 and R1.4 and leave R1.3 unused.



In addition to the card placement, you must also configure the function of the WCS Subracks in the ERA GUI. For further information, refer to the ERA configuration guide for Software Version 2.5 or later; see "[Accessing ERA Series User Documentation](#)" on page 82.



## Cabling OPT Cards to Connect a TEN to a Switching CAN

In this process you will connect SFP+ Modules to the fiber cable and then use the cable to connect a TEN to a Switching CAN.



The graphics used in this process show a WCS-4 Subrack as a Switching CAN, and a WCS-2 Subrack as a TEN. The same rules for slots and port connections apply if the Switching CAN was a WCS-2 Subrack or the TEN was a WCS-4 Subrack.

- 1 Complete the steps in "SFP+ Modules Tested for use with ERA" on page 61.
- 2 Obtain a pair of SFP+ Modules that correspond to the length and type of fiber you will use to connect the CAN to the TEN or the WIN. Note the maximum range listed in Table 13 on page 60.
- 3 Follow local practice or manufacturer recommendations to clean fiber connectors.
- 4 Connect one end of the cable with an SFP+ Module into one of the OPT Card ports (labeled 1 - 4) installed in the Switching CAN—you can only use Slots L1 - L8 in the Switching CAN.
- 5 Connect the other end of the cable with an SFP+ Module into an OPT Card in the TEN, as follows:
  - Use Port R1.1 to connect to the Switching CAN.
  - Use Ports R1.2 through R1.4 for additional TEN-to-CAN links.

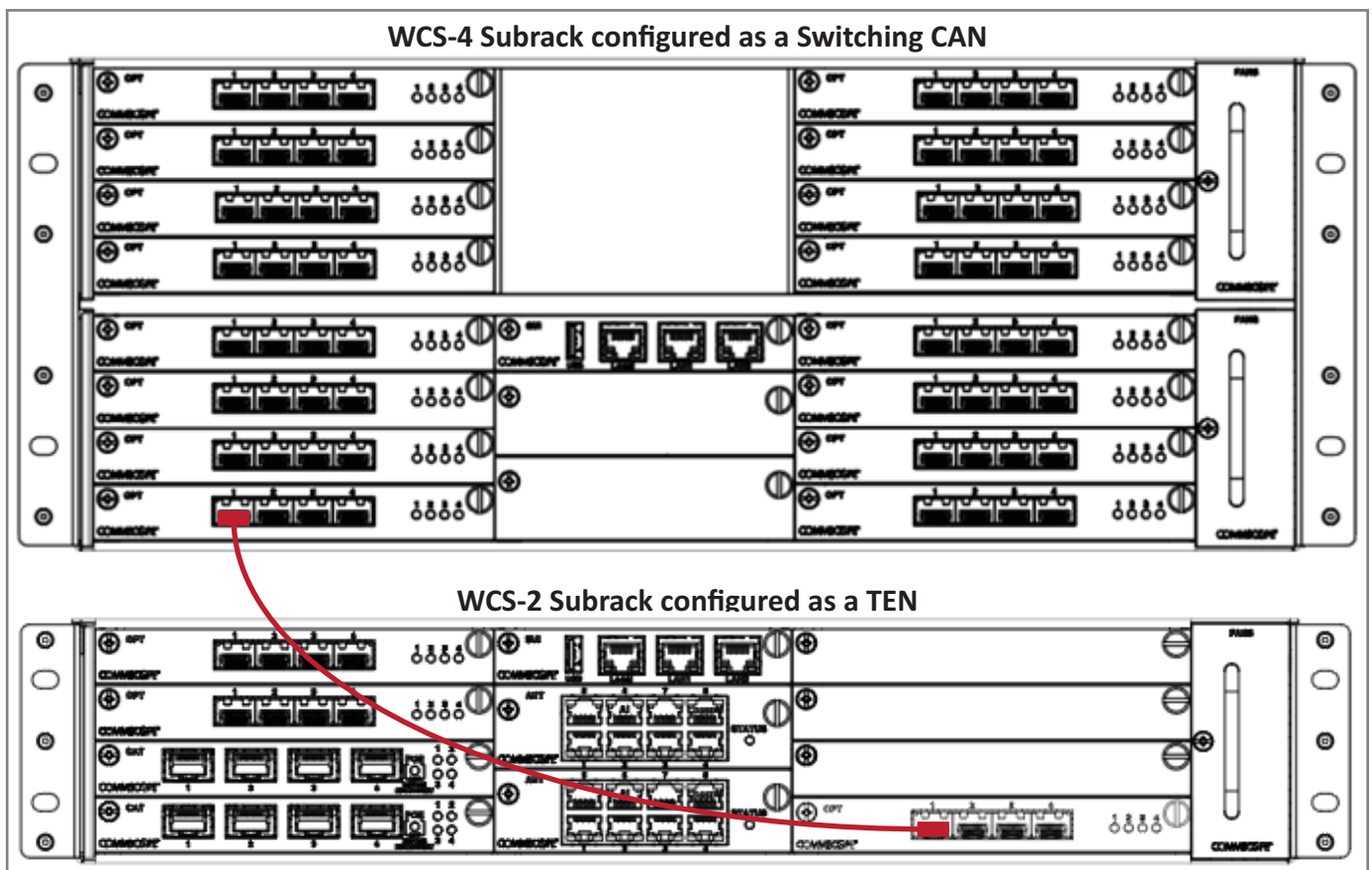

- 6 (Optional). To add an additional 320 MHz of RF between the TEN and the Switching CAN, do the following:
  - a Obtain a pair of SFP+ Modules that correspond to the length and type of fiber you will use to connect the CAN to the TEN. Note the maximum range listed in [Table 13 on page 60](#).
  - b Follow local practice or manufacturer recommendations to clean fiber connectors.
  - c Connect one end of the cable with an SFP+ Module into one of the four ports on the OPT Card (labeled 1 - 4) installed in the Switching CAN.
  - d Connect the other end of the cable with an SFP+ Module into **Port 2** on the OPT Card installed in **Slot R1** of the TEN.

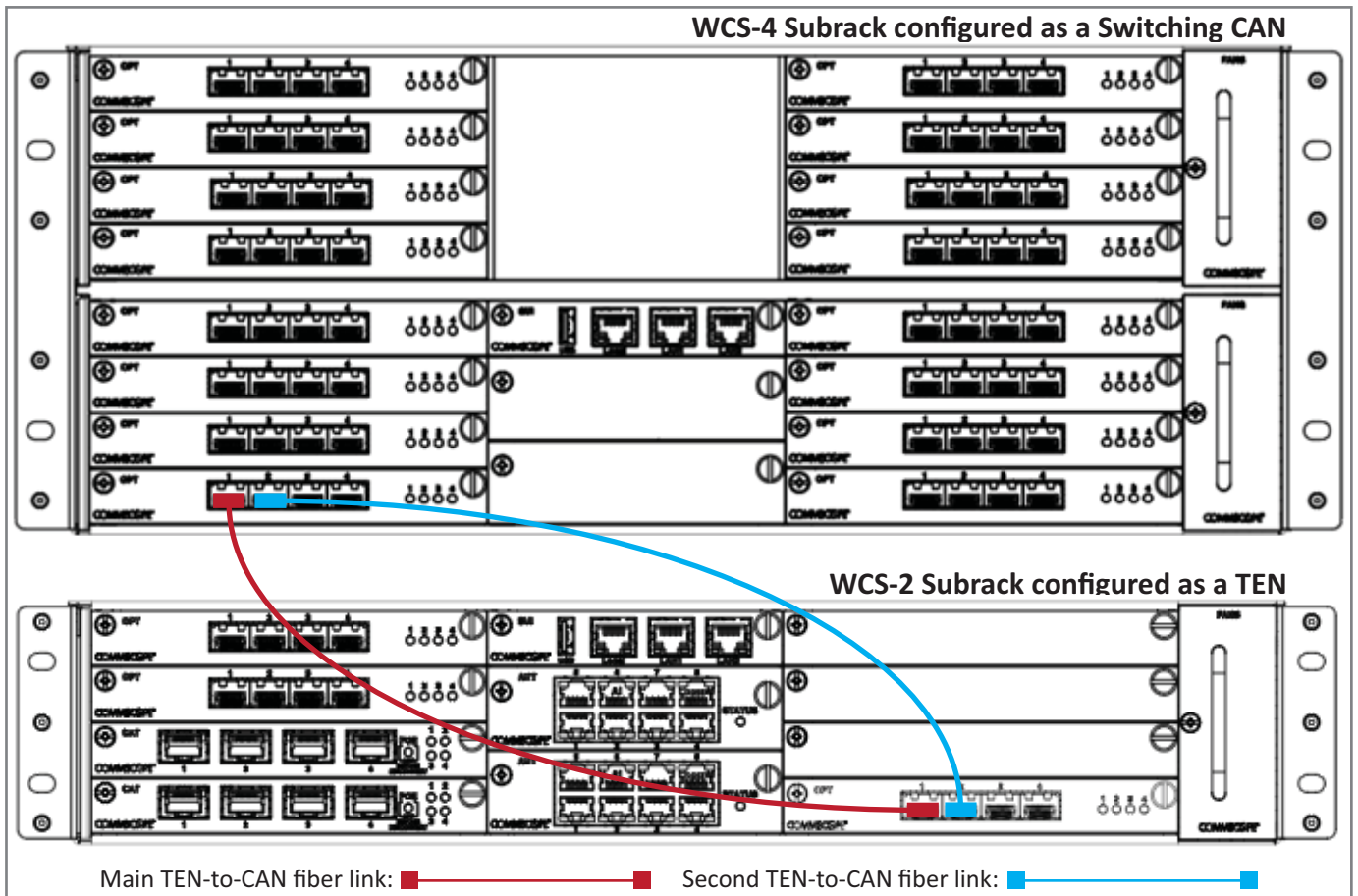

- 7 (Optional). To add additional TEN-to-CAN links, with each link adding an additional 320 MHz of RF capacity between the TEN and Switching CAN, follow the process in [Step 6](#), as needed for each additional link. However, you will now use Ports **R1.2** through **R1.4**, which must be populated consecutively—there cannot be unused ports between used ports. That is, you cannot use Port **R1.2** and **R1.4** and leave **R1.3** unused.



In addition to the card placement, you must also configure the function of the WCS Subracks in the ERA GUI. For further information, refer to the ERA configuration guide for Software Version 2.5 or later; see "[Accessing ERA Series User Documentation](#)" on page 82.

## Cabling OPT Cards for Connecting to a Fiber AP



This procedure tells you how to connect an OPT Card in a CAN or a TEN to a Fiber AP. For full installation instructions, refer to the applicable Fiber AP installation guide. See ["Accessing ERA Series User Documentation"](#) on page 82.

In this process you will connect SFP+ Modules to the fiber cable, and then use the cable to connect a CAN or a TEN to a Fiber AP.

- 1 Contact your local CommScope sales representative to obtain the following components, as required, for this installation.
  - Per the installation plan, obtain either SMF or MMF that is of sufficient length to reach from the Fiber AP to the CAN or TEN.
  - Obtain a pair of SFP+ Modules that is appropriate for this installation. [Table 14 on page 61](#) identifies the available SFP+ Modules.
  - The AP includes one Optical OCTIS Kit (PN 7770612). Obtain an additional kit to cascade APs.
- 2 Connect the Optical Port 1 on the Fiber AP, as appropriate for this installation.
  - a Remove the dust cap from Optical Port 1 on the Fiber AP, and from the connectors on the SMF or MMF (see graphic that follows).

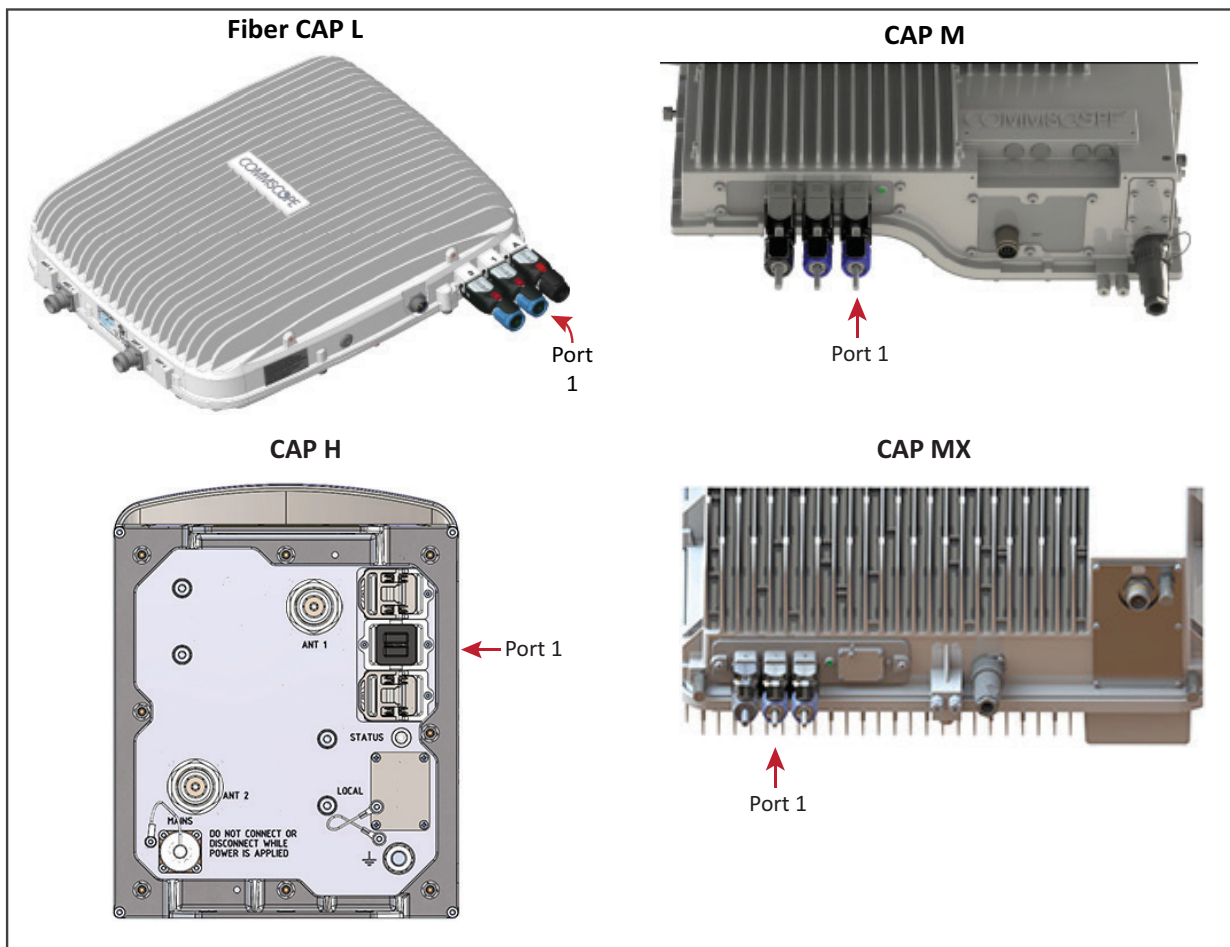

- b Follow the local cleaning technique to clean Optical Port 1 on the Fiber AP.
- c Clean the connectors on the SMF or MMF following the fiber supplier's recommendations.
- d Install the SFP+ Module and Optical OCTIS Kit on the end of the SMF or MMF that will connect to the Fiber AP, and then connect it to Optical Port 1 on the Fiber AP (see the preceding graphic). Refer to the technical data sheet that ships with the OCTIS Kit for further information.
- e Connect the other end of the fiber and SFP+ module to an open port on an OPT Card. (The OPT Card should only be installed in L1, L2, L3, or L4.)



**If installing a CAP L with the CAP L Hybrid Fiber Splice Box Kit (PN 7774354-xx), the optical fiber will be hanging from the Hybrid Fiber Splice Box.**

- 3 Complete the steps in "[SFP+ Modules Tested for use with ERA](#)" on page 61.

## Connect the CAT Cards

This procedure tells you how to connect an AP to a CAT Card installed in a Classic CAN or a TEN. Card Cards cannot be used in a Switching CAN or WIN. In a cascaded AP configuration, you connect the CAT Card to the Main AP.



**CAT Cards are hot swappable; you do not need to power down the CAN or TEN to install or remove an CAT Card.**



**The -48 Vdc WCS subracks do not supply power over CAT6A to UAPs or Copper CAP L APs.**

- 1 Follow the steps in one of the following sections to install the CAT Cards in Slots L1 - L4 of a Classic CAN or a TEN, as needed for this installation:
  - "[Slot and Card Assignment Rules for Classic CANs](#)" on page 18
  - "[Slot and Card Assignment Rules for TENs](#)" on page 21.

- 2 Use 23 AWG (minimum) Cat6A cables to connect up to four APs to the CAT Card as described below and as shown in the graphic below. When making this connection, observe the cabling rules identified in "Cat6A Cables and Connectors" on page 31.
- UAP, UAP-N25, UAP-X, and UAP-XN25—connect the CAT Card port to the UAP Main port.
  - Copper CAP L—connect the CAT Card port to the CAP L RJ-45 port.

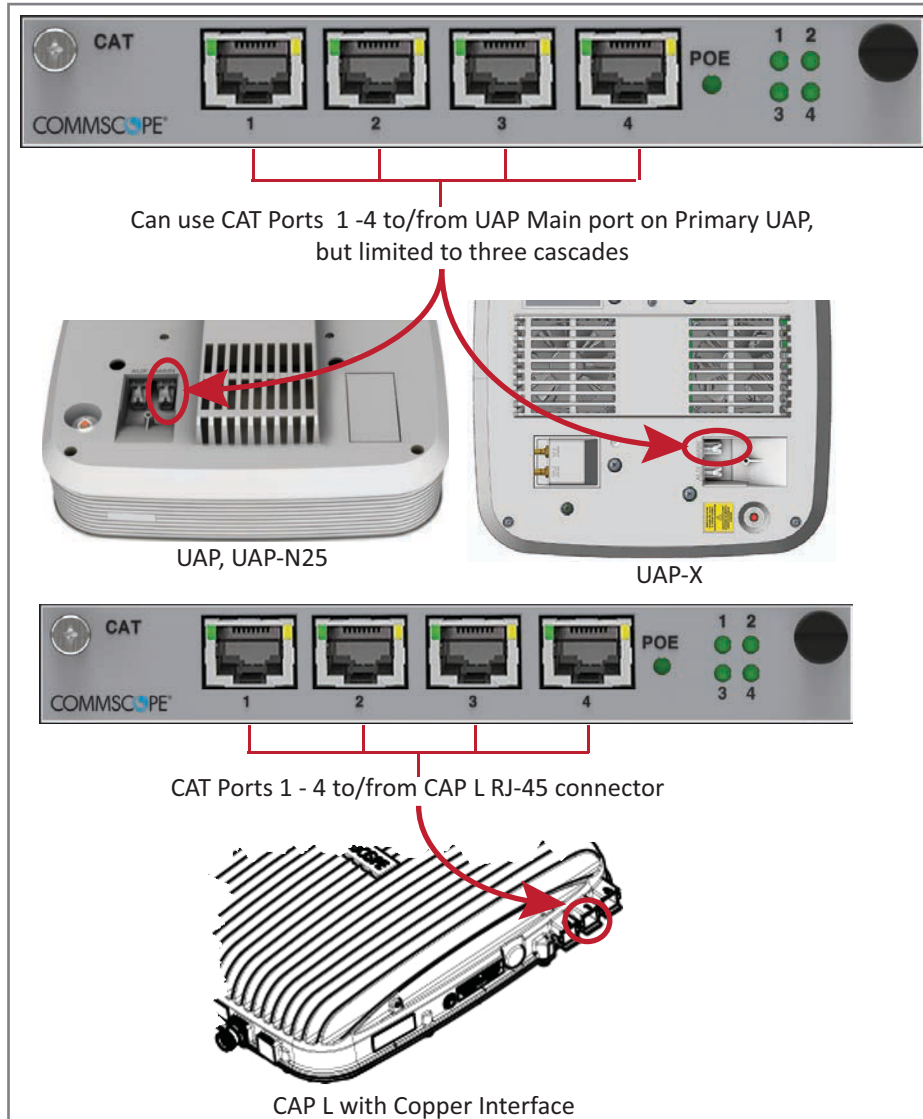

- 3 Use a testing device that provides an integrated test for Cat6A to make sure the Cat6A connections meet the requirements listed in "Cat6A Cables and Connectors" on page 31.

## Connect the AUT Cards

The following rules apply to the AUT Card ports 1 - 8.

- The outside network that supports the Ethernet device connected to the AP must be connected to the corresponding AUT Card and port of the Subrack containing the CAT/OPT card to which the AP is connected.
- Because the path from the AP AUX port to an AUT port path is a pass-through connection, no extra network setup procedures for the Ethernet device are required.
- The AUT path is independent of the signal set assigned to an AP, however, the maximum transport bandwidth for the AP is reduced from 320 MHz to 285 MHz when an Ethernet device is connected to the AP.
- An Ethernet device such as a camera can be connected to the AUX port of an AP if AUT Cards are installed in the TEN or CAN.
- The AUX port of a cascaded (secondary) AP cannot be used to connect an Ethernet device.
- The AUT Card ports do not supply power, however, the AP does supply Remote Power over Cat6A to connected Ethernet devices.
- 1 Gbps and 100 Mbps Ethernet devices are supported, however, the type of device supported is dependent on the type of device connected to the AUT port.
  - If a 100 Mbit/s Ethernet device is connected to the AUT port, then the Ethernet device connected to the associated AP must also be a 100 Mbit/s device.
  - If a 1 Gbit/s Ethernet device is connected to the AUT port, then either a 100 Mbit/s device or a 1 Gbit/s device may be connected to the associated AP.



**AUT Cards are hot swappable; you do not need to power down the CAN or TEN to install an AUT Card.**



**An AP will experience a Loss of Service that lasts approximately 1.5 minutes when a cascaded AP or an Ethernet device is connected to its AUX port. APs re-flash and reboot whenever an Ethernet device is initially added or when the type of device (AP or Ethernet device) connected to the AUX port is changed. The blue LED on the AP blinks while the AP is re-flashing without interrupting service, but during the reboot the AP experiences approximately 1.5 minutes of Loss of Service.**



**An AUT Card cannot be used in a Switching CAN or a WIN.**

Figure 13 shows the internal mapping between WCS slots and CAT/OPT Card ports to AUT Card slots and ports. There is a specific relationship between the slot in which the CAT and AUT Cards are installed, and the CAT and AUT Card ports. For example:

- The CAT/OPT Card slot/port combination of **L1.1** always maps to AUT Card slot/port combination **M1.1**
- The CAT/OPT Card slot/port combination **L4.4** always maps to AUT Card slot/port combination **M2.8**.

This internal mapping provides the Ethernet backhaul for Ethernet devices connected to the Ethernet ports on the AUT Card.



**Figure 13** shows the CAT Card installed in Slots L1 - L4. The mapping shown would be the same for an OPT Card installed in Slots L1 - L4.



WCS Slot (L1 - L4)	CAT/OPT Card Port	AUT Card Slot (M1 - M2)	AUT Card Port
L1	1	M1	1
L1	2	M1	2
L1	3	M1	3
L1	4	M1	4
L2	1	M1	5
L2	2	M1	6
L2	3	M1	7
L2	4	M1	8

WCS Slot (L1 - L4)	CAT/OPT Card Port	AUT Card Slot (M1 - M2)	AUT Card Port
L3	1	M2	1
L3	2	M2	2
L3	3	M2	3
L3	4	M2	4
L4	1	M2	5
L4	2	M2	6
L4	3	M2	7
L4	4	M2	8

**Figure 13.** Internal Mapping of CAT/OPT Card Slots and Ports to AUT Card Slots and Ports

Use the preceding information and the following steps to connect the AUT Card(s) to the ERA system.

- 1 Follow the steps in "Install and Connect the Subrack Cards" on page 55 to install the AUT Card(s) into the WCS Subrack Slots M1 - M2, as needed for this CAT/TEN installation.
- 2 Use to Figure 13 as a reference for port assignments of auxiliary devices subtended off an AP.

## Connect the CDD Cards

The following sections guide you through the installation of a CDD Card. Adhere to all product safety and compliance cautions and follow the steps in the order presented.

### Calculate the Power Draw

The maximum power draw for a CDD Card is 40 Watts. To determine the power draw of all CDD Cards installed in the CAN, multiply the number of CDD Cards installed by 40 Watts.



**This calculation is for the CDD Card only.**

### Connect the CDD Card to the BBU



**CDDs are hot swappable; you do not need to power down the CAN or WIN to install or remove a CDD.**

- 1 If necessary, contact your local Nokia sales representative to obtain the required number of SFP Modules for this installation. The CPRI line rate is determined by each installation; care must be taken to order the proper speed grade SFP Module based on the installation requirements.



**Do not use CommScope ERA SFP+ Modules in the CDD Card.**

- 2 Slide an SFP Module into a CDD Card CPRI Port (labeled 1 - 6), and then push the SFP Module into the CDD Card until you hear it click into place.



**Should you need to remove an SFP Module, do the following in the order presented to prevent damage to the SFP Module, the CDD Card, or the fiber.**

1. **Disconnect the fiber cable.**
  2. **Pull down on the extraction lever on the SFP Module.**
  3. **Use the extraction lever to carefully pull the SFP module out of the CDD Card slot.**
- 3 Obtain the required length of Single-Mode Fiber cable (with loss of less than 13 dB) that has a dual-fiber LC jumper that can reach from a CDD Card CPRI port in the Classic CAN or WIN to a CPRI port on the Nokia AirScale FSM4 ABIA Module in the BBU.
  - 4 Connect one end of the cable to an SFP Module installed in a CDD Card CPRI Port (labeled 1 - 6).
  - 5 Connect the other end of the cable to a CPRI port on the Nokia AirScale ABIA Module, where the CPRI ports are labeled RF-*n* where *n* is the port number (1 - 6).

Refer to the following graphics for examples of BBU to CDD Card connectivity:

- For Classic CAN installations, see [Figure 14 on page 75](#)
- For WIN installations, see [Figure 15 on page 76](#).



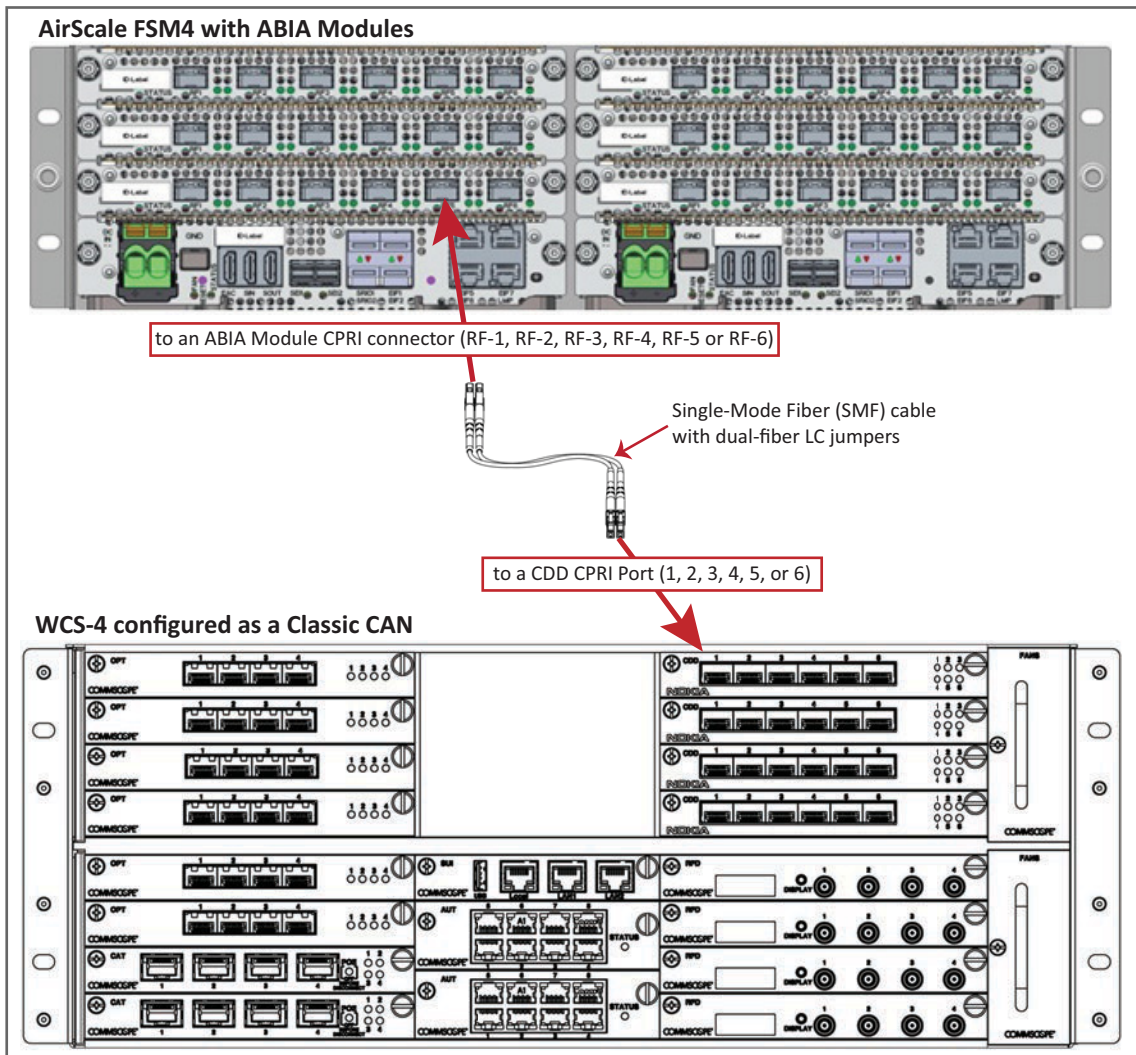

Figure 14. CDD Card in a Classic CAN Connecting to a BBU

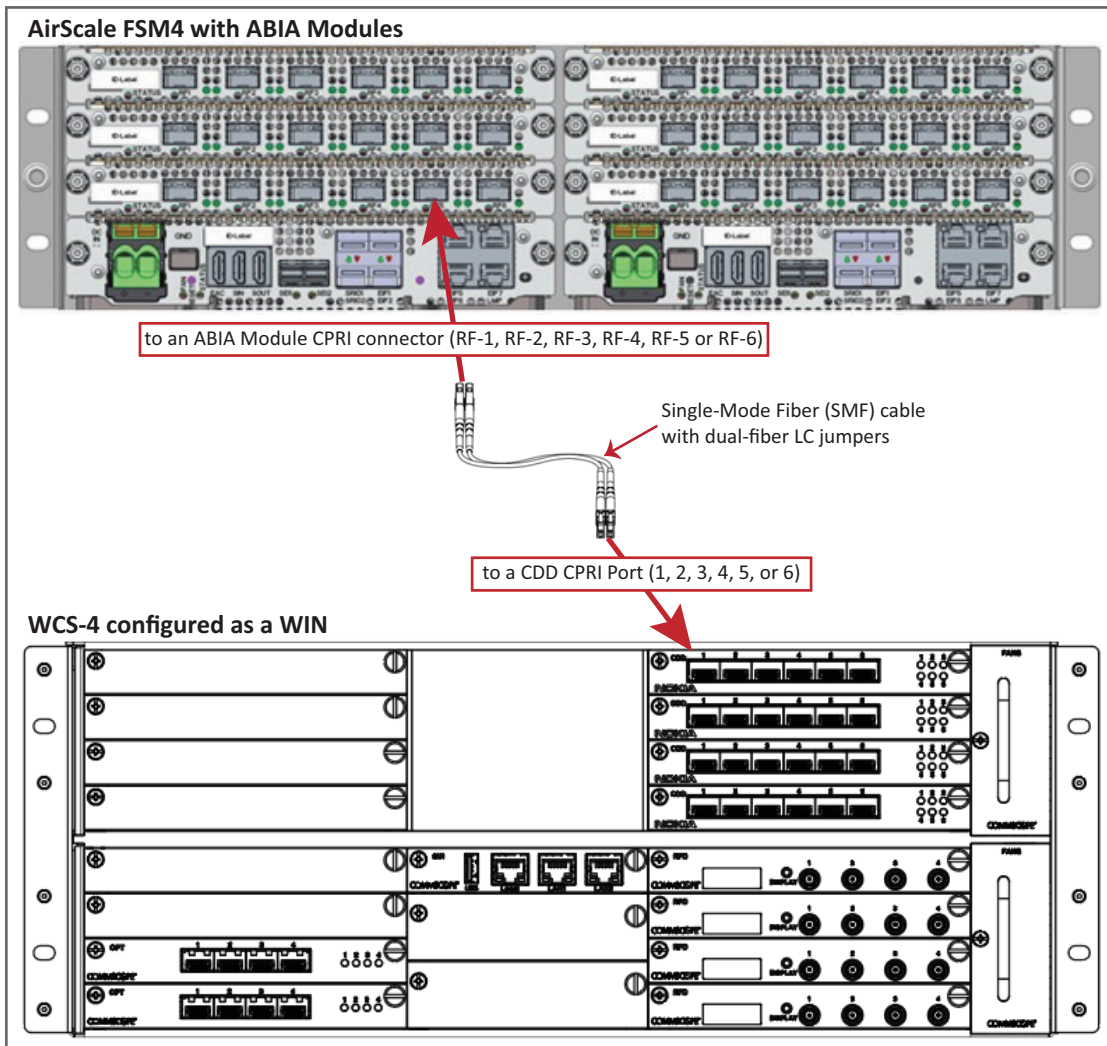

Figure 15. CDD Card in a WIN Connecting to a BBU

## MAINTENANCE

The following sections provide maintenance information.

### WCS Subrack Filter Module Maintenance

The WCS-2 Subrack has one Filter Module, and the WCS-4 Subrack has two Filter Modules on the left-hand side of the chassis (see "WCS Subrack Fan Trays and Filter Modules" on page 30). Air enters the Subrack on the left side of the chassis and exits on the right by the Fan Tray.

The Filter Modules should be checked every six months to make sure they are clear of dust and cleaned if necessary. A dirty Filter Module will inhibit fresh air flow and can cause temperature alarms. CommScope has found that CAT Cards are typically first to show temperature alarms if the Filter Module becomes clogged.

### Removing a WCS Subrack Filter Module

WCS Subrack Filter Modules can be pulled out with your fingers, as there are no screws—Filter Modules are retained in the WCS Subrack chassis by friction. However, you may have to use a screwdriver or a flat blade under the lip of the Filter Module frame to help pry it out of its slot. Filter Modules can be pulled out while the system is running.

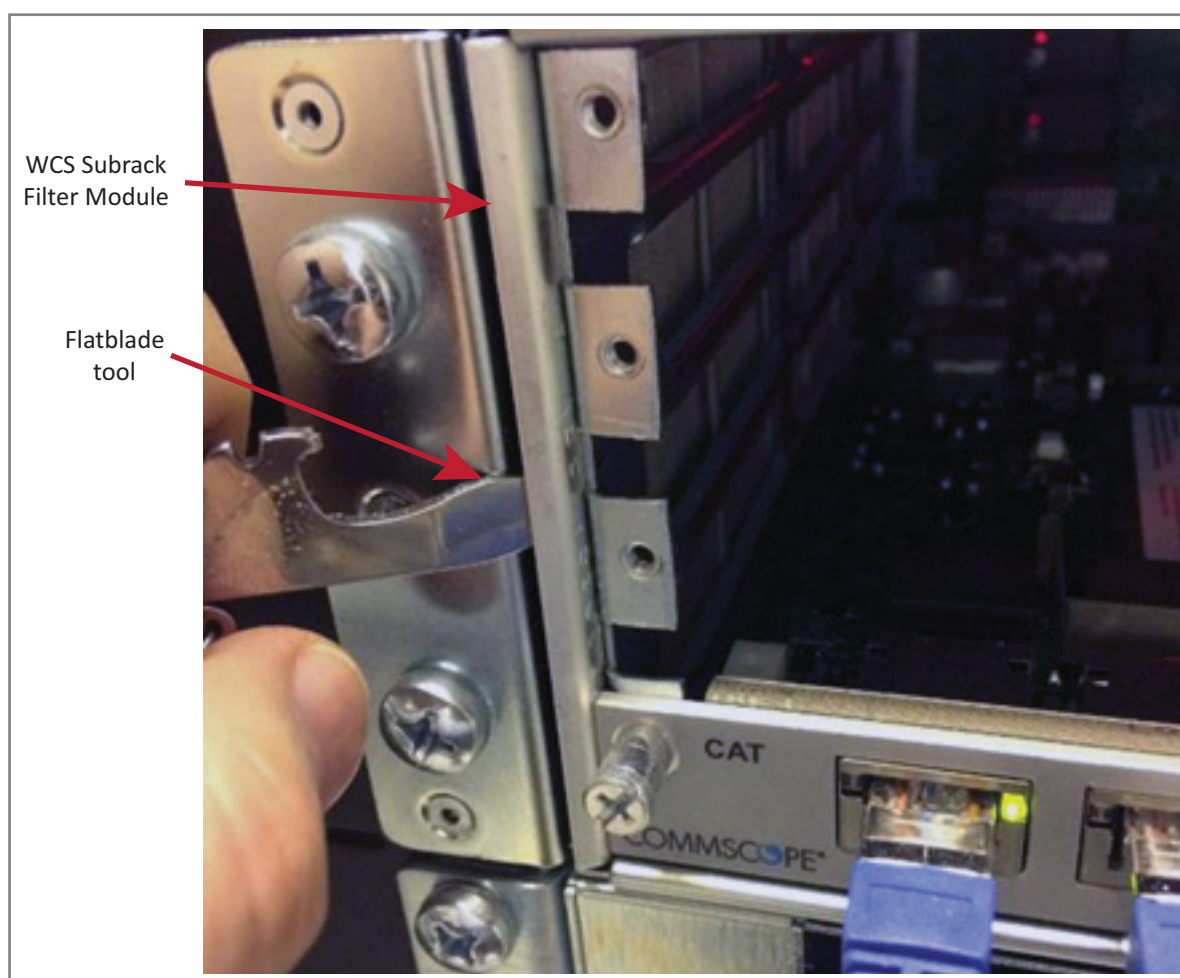

**Figure 16.** Removing a WCS Filter Module

## Cleaning a WCS Subrack Filter Module

The Filter Modules are reusable, and can be cleaned with a brush, vacuum, or water. If water is used, as much dust as possible should be removed before getting the Filter Module wet. [Figure 17](#) shows examples of a clean and a dirty Filter Module.



**When cleaning a Filter Module, take care so you do not damage the EMI gasket at the front of the filter frame. If the Filter Module becomes damaged and cannot be reinstalled, contact your local CommScope sales representative to order a new Filter Module (PN 7700691-xx).**



**Do not clean the Filter Module with water in the same vicinity as the WCS Subrack or other electronics. Wet conditions increase the potential for receiving an electrical shock when installing or using electrically powered equipment. Make sure the Filter Module is completely dry before replacing it in the WCS Subrack chassis.**

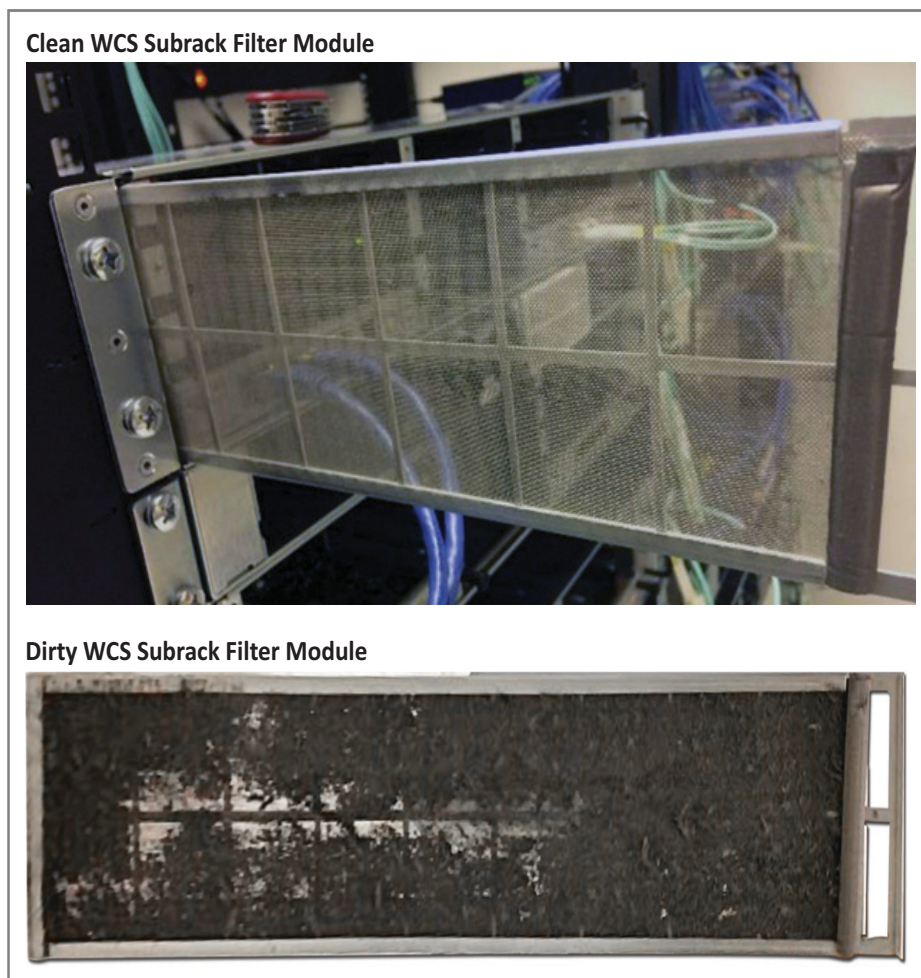

**Figure 17.** Examples of Clean and Dirty WCS Subrack Filter Modules

## Installing a WCS Subrack Filter Module

To install a cleaned or new Filter Module, slide the filter into its slot and press firmly until its edge is aligned with the front faceplate of the WCS Subrack chassis and cannot be pushed in any further.

## Removing an e-POI Module from an e-POI Subrack



e-POI modules are hot swappable; you do not need to power down the e-POI subrack to add or remove an e-POI module, but you should follow the instructions below to ensure that false alarms are not generated due to a missing e-POI module.

The ERA Software automatically detects when an e-POI Module is added to an e-POI Subrack. Should you need to remove an e-POI Module, you must do the following:

- 1 Disconnect the Ribbon cable from the e-POI Module that you are removing from the e-POI Subrack.
- 2 Loosen the two thumbscrews on the bottom of the e-POI Module and pull it from the Subrack.
- 3 Press the Config button on the IFC for 5 seconds. This tells the ERA Software to scan and delete the removed e-POI Module from inventory and clear any alarms related to that e-POI Module.
- 4 Wait for the e-POI Module Status LEDs on the IFC to flash off and then on, which indicates that the IFC has been reconfigured.

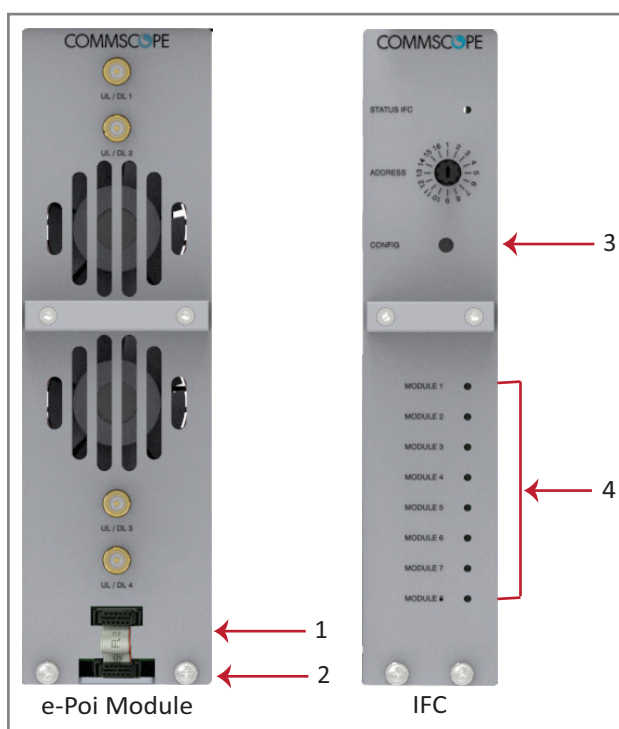

# CAT6A SPECIFICATIONS AND TESTING REQUIREMENTS

Cat6A connections must be tested with a device that can measure the cable parameters against the thresholds defined in ANSI/TIA standards (such as the Fluke DTX-1800 and DSX-5000). Figure 18 shows the end-to-end channel from the CAN/TEN to the CAP L, which is inclusive of the Cat6A cable, the Cat6A Patch Cord, and the Panel and connection box. The end-to-end channel must meet the Cat6A U/UTP performance defined by the TIA/EIA 568 C.2 standard; see Table 15.

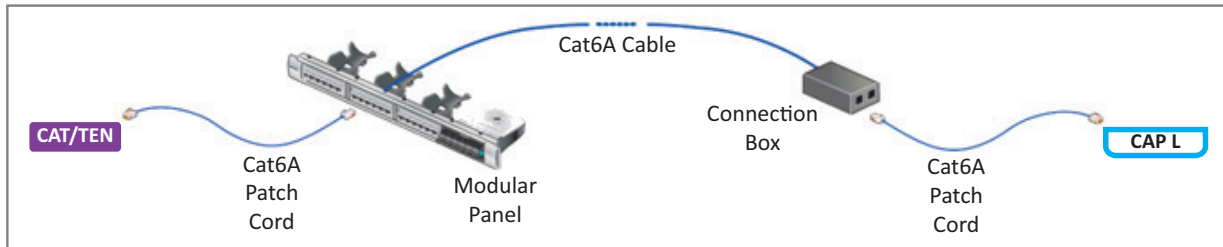

Figure 18. ERA End-to-End Channel



Some cables list their performance in “typical” performance values. However, sweep-testing is necessary to confirm actual performance. CommScope strongly recommends using Cat6A cable that has been tested to the listed frequency with test confirmation available for inspection.

Table 15. Cat6A U/UTP Performance Standards (TIA/EIA 568 C.2)

MHz	Insertion Loss (dB) Channel/Link	NEXT (dB) Channel/Link	PSum NEXT (dB) Channel/Link	ACRF (dB) Channel/Link	PSum ACRF (dB) Channel/Link	Return Loss (dB) Channel/Link
1	2.3/1.9	65.0/65.0	62.0/62.0	63.3/64.2	60.3/61.2	19.0/19.1
4	4.2/3.5	63.0/64.1	60.5/61.8	51.2/52.1	48.2/49.1	19.0/21.0
8	5.8/5.0	58.2/59.4	55.6/57.0	45.2/46.1	42.2/43.1	19.0/21.0
10	6.5/5.5	56.6/57.8	54.0/55.5	43.3/44.2	40.3/41.2	19.0/21.0
16	8.2/7.0	53.2/54.6	50.6/52.2	39.2/40.1	36.2/37.1	18.0/20.0
20	9.2/7.8	51.6/53.1	49.0/50.7	37.2/38.2	34.2/35.2	17.5/19.5
25	10.2/8.8	50.0/51.5	47.3/49.1	35.3/36.2	32.3/33.2	17.0/19.0
31.25	11.5/9.8	48.4/50.0	45.7/47.5	33.4/34.3	30.4/31.3	16.5/18.5
62.5	16.4/14.1	43.4/45.1	40.6/42.7	27.3/28.3	24.3/25.3	14.0/16.0
100	20.9/18.0	39.9/41.8	37.1/39.3	23.3/24.2	20.3/21.2	12.0/14.0
200	30.1/26.1	34.8/36.9	31.9/34.3	17.2/18.2	14.2/15.2	9.0/11.0
250	33.9/29.5	33.1/35.3	30.2/32.7	15.3/16.2	12.3/13.2	8.0/10.0
300	37.4/32.7	31.7/34.0	28.8/31.4	13.7/14.6	10.7/11.6	7.2/9.2
400	43.7/38.5	28.7/29.9	25.8/27.1	11.2/12.1	8.2/9.1	6.0/8.0
500	49.3/43.8	26.1/26.7	23.2/23.8	9.3/10.2	6.3/7.2	6.0/8.0



Propagation Delay is 555 nanoseconds for channel/498 nanoseconds for link tested at 10 MHz.



Delay Skew is 50 nanoseconds for channel/44 nanoseconds for link tested at 10 MHz.



For additional information, see also *CommScope Product Specifications for the GigaSPEED X10D® 2091B ETL Verified Category 6A U/UTP Cable (760107201 | 2091B BL 4/23 W1000)*. (Click [here](#) access the document online.)

## CONTACTING COMMSCOPE

The following sections tell you how to contact CommScope for additional information or for assistance.

### CMS Global Technical Support

The following sections tell you how to contact the CommScope Mobility Solutions (CMS) Technical Support team. Support is available 7 days a week, 24 hours a day.

#### Telephone Helplines

Use the following Helpline telephone numbers to get live support, 24 hours a day:

- 24x7** +1 888-297-6433 (Toll free for U.S. and Canada)
- EMEA 8:00-17:00 (UTC +1)** + 800 73732837 (Toll free for parts of EMEA and Australia)  
+ 49 909969333 (Toll charge incurred)

Calls to an EMEA Helpline outside of the 8:00 to 17:00 time frame will be forwarded to the 24x7 Helpline.

#### Online Support

- To go to the CommScope **Wireless Support Request** web page from which you can initiate a Technical Support ticket, do one of the following:
  - Scan the QR Code to the right.
  - If viewing this document online as a PDF, click on the following URL link:  
<http://www.commscope.com/wisupport>
- Follow the online prompts to initiate a Technical Support ticket.



### Waste Electrical and Electronic Equipment Recycling

Country specific information about collection and recycling arrangements per the Waste Electrical and Electronic Equipment (WEEE) Directive and implementing regulations is available on CommScope's website.

To access information on the CommScope recycling program, do any of the following:

- Scan the QR Code to the right.
- If viewing this document online as a PDF, click on the following URL link:  
<http://www.commscope.com/corporate-responsibility-and-sustainability/environment/weee-customer-recycling/>
- Enter the preceding URL into your web browser, and then press **ENTER** on your keyboard.



## Hardware to Software Mapping Information

- 1 To view or download a document that lists the minimum software requirements for ERA hardware, do one of the following:
  - Scan the QR Code to the right.
  - If viewing this document online as a PDF, click on the following URL link:  
<http://www.commscope.com/resources/in-building-wireless>
- 2 Click on a document link to open it, or right click on the link and select the **Save target as...** option from the contextual menu.



## Technical Training

- 1 To access the CommScope University Training site, please use the following web address or scan the QR code to the right:  
[www.commscopeuniversity.com](http://www.commscopeuniversity.com)
- 2 Once you are logged in, you can search for training by typing search words in the search field or by going to the Course Catalog to view the available courses.
- 3 Instructor-led courses are conducted in North America and Europe. Before choosing a course, please verify the region.



For training related questions, please contact us:

**Americas:** DASTrainingUS@CommScope.com

**EMEA:** DASTrainingEMEA@CommScope.com

## Accessing ERA Series User Documentation

- 1 To access ERA user documentation on the CommScope DCCS Customer Portal web page, do one of the following:
  - Scan the QR Code to the right to go directly to the CommScope DCCS Customer Portal, where you can access the ERA user documentation.
  - If viewing this document online as a PDF, click on the following URL link:  
<https://www.commscope.com/membership>
- 2 Access to the Customer Portal requires a user account and password. On the **Sign in** page, do one of the following:
  - If you have an account, enter your **Email** and **Password**, and then click **Sign In**.
  - If you don't have an account, in the **Register Today** panel, click **Register** and follow the prompts.
- 3 On the **My CommScope** page, click **DCCS**.
- 4 If prompted with **Please sign in to continue**, enter your **Email** and **Password**, and then click **Sign In**.
- 5 Under the **Site** list, select your site name.
- 6 In the **Welcome** page, click **ERA**.
- 7 Click on the title of any document to open it.







