

Test Site:
FCC Test Site No.: 96997
IC OATS No.: IC3475A-1



ECL-EMC Test Report No.: 15-217

Equipment under test: **ION-U EB L 23/23 Vac**
FCC ID: **XS5-UEBL2323**
IC ID:
Type of test: **FCC 47 CFR Part 27 Subpart H, F: 2015**
Miscellaneous Wireless Communication Services

Measurement Procedures: 47 CFR Parts 2: 2015 (*Frequency Allocations and Radio Treaty Matters; General Rules and Regulations*),
Part 27: 2015 (*Miscellaneous Wireless Communication Services*),
ANSI/TIA-603-C:2004, *Land Mobile FM or PM Communications Equipment Measurement and Performance Standards*

Test result: **Passed**

Date of issue:	21.10.15	Signature:	
Issue-No.:	01	Author:	
Date of delivery:	10.08.15	Checked:	
Test dates:	10.08. – 08.09.15		
Pages:	54		



Manufacturer: ANDREW Wireless Systems GmbH
Industriering 10

D-86675 Buchdorf

Tel.: +49 (0)9099 69 0

Fax: +49 (0)9099 69 140

Test Location: Bureau Veritas Consumer Products Services
Germany GmbH

European Compliance Laboratory (ECL)

Thurn-und-Taxis-Straße 18

D-90411 Nürnberg

Tel.: +49 40 74041 0

Fax: +49 40 74041-2755

General:

The purpose of this report is to show compliance to the FCC regulations for devices operating under Part 27 of the Code of Federal Regulations title 47.

This report informs about the results of the EMC tests, it only refers to the equipment under test. No part of this report may be reproduced in any form, without written permission.



Table of contents

1 TEST RESULTS SUMMARY5

2 EQUIPMENT UNDER TEST (E.U.T.)6

 2.1 DESCRIPTION6

 2.1.1 DOWNLINK6

 2.1.2 UPLINK6

 2.1.3 DESCRIPTION OF EUT7

 2.1.4 BLOCK DIAGRAM OF MEASUREMENT REFERENCE POINTS8

 2.1.5 DOWNLINK SYSTEM GAIN AND OUTPUT POWER.....9

3 TEST SITE (ANDREW BUCHDORF)10

 3.1 TEST ENVIRONMENT10

 3.2 TEST EQUIPMENT10

 3.3 INPUT AND OUTPUT LOSSES11

 3.4 MEASUREMENT UNCERTAINTY11

4 TEST SITE (BUREAU VERITAS CONSUMER PRODUCTS SERVICES)11

5 RF POWER OUT: §27.50, §2.104612

 5.1 LIMIT.....12

 5.2 TEST METHOD12

 5.3 TEST RESULTS.....13

 5.3.1 DOWNLINK.....13

 5.3.1.1 LTE; 5 MHz signal15

 5.3.1.2 LTE; 10 MHz signal16

 5.3.2 UPLINK17

 5.4 SUMMARY TEST RESULT.....17

6 OCCUPIED BANDWIDTH: §2.104918

 6.1 LIMIT.....18

 6.2 TEST METHOD18

 6.3 TEST RESULTS18

 6.3.1 DOWNLINK.....18

 6.3.1.1 LTE; 5 MHz signal; OBW 99%20

 6.3.1.2 LTE; 5 MHz signal; OBW 26dB21

 6.3.1.3 LTE; 10 MHz signal; OBW 99%22

 6.3.1.4 LTE; 10 MHz signal; OBW 26dB23

 6.3.2 UPLINK24

 6.4 SUMMARY TEST RESULT.....24

7 SPURIOUS EMISSIONS AT ANTENNA TERMINALS: §27.53, §2.1051.....25

 7.1 LIMIT.....25

 7.2 TEST METHOD26

 7.3 TEST RESULTS26

 7.3.1 DOWNLINK.....26

 7.3.1.1 LTE; 2 x 5 MHz signal27

 7.3.1.2 LTE; 10 MHz signal31



7.3.2	UPLINK	34
7.4	SUMMARY TEST RESULT	34
8	INTERMODULATION: §27.53, §2.1051.....	35
8.1	LIMIT.....	35
8.2	TEST METHOD	36
8.3	TEST RESULTS	36
8.3.1	DOWNLINK	36
8.3.1.1	LTE; 2 x 5 MHz signal.....	37
8.3.1.2	LTE; 10 MHz signal	38
8.3.2	UPLINK	38
8.4	SUMMARY TEST RESULT	38
9	OUT OF BAND REJECTION	39
9.1	LIMIT.....	39
9.2	TEST METHOD	39
9.3	TEST RESULTS	39
9.3.1	DOWNLINK	40
9.3.2	UPLINK	40
9.4	SUMMARY TEST RESULT	40
10	RADIATED SPURIOUS EMISSIONS AT THE ECL (BV): §27.53, §2.1051	41
10.1	METHOD OF MEASUREMENT	45
10.2	LIMIT	46
10.3	RECEIVER SETTINGS.....	47
10.4	CLIMATIC VALUES IN THE LAB	47
10.5	TEST RESULTS.....	48
10.5.1	30 MHz TO 1 GHz DOWNLINK (BOTTOM – MIDDLE – TOP)	48
10.5.3	30 MHz TO 1 GHz DOWNLINK (MIDDLE OF ALL PATHS)	49
10.5.4	1 GHz TO 20 GHz DOWNLINK (BOTTOM – MIDDLE – TOP)	50
10.5.6	1 GHz TO 20 GHz DOWNLINK (MIDDLE OF ALL PATHS).....	51
10.5.7	18 GHz TO 26 GHz DOWNLINK (BOTTOM – MIDDLE – TOP)	52
10.5.9	18 GHz TO 26 GHz DOWNLINK (MIDDLE OF ALL PATHS).....	53
11	HISTORY	54



1 Test Results Summary

Name of Test	FCC Para. No.	FCC Method	FCC Spec.	Result
RF Power Output	27.50(a)	2.1046	2000 Watts / 5 MHz E.I.R.P	Complies
Occupied Bandwidth	2.1049	2.1049	Input/Output	Complies
Spurious Emissions at Antenna Terminals	27.53(a)	2.1051	-13dBm	Complies
Radiated Spurious emission	27.53(m)	2.1053 TIA/EA-603	-13dBm E.I.R.P	Complies
Intermodulation	KDB 935210 D02 v03	KDB 935210 D02 v03	KDB 935210 D02 v03	Complies
Frequency Stability	27.54	2.1055	Must stay in band	NA
Out of Band Rejection	KDB 935210 D02 v02	KDB 935210 D03 v03	KDB 935210 D03 v03	Complies

Frequency stability is given by: The system gets an electrical analog signal from the BSS which is converted into an analog optical signal, transmitted by the optical links and then reconverted in the Remote Unit into an analog electrical signal. During this process happens no frequency change/modification, so input and output have same frequency what can be seen under clause "Occupied Bandwidth".



2 Equipment under test (E.U.T.)

2.1 Description

Kind of equipment (Extension Unit 2)	ION-U EB L 23/23 Vac	
Andrew Ident. Number	TFBH23/23-1	
Serial no.(SN)	11	
Revision	00	
Software version and ID	n. a.	
Type of modulation and Designator	LTE (G7D)	<input checked="" type="checkbox"/>
Frequency Translation	F1-F1	<input checked="" type="checkbox"/>
	F1-F2	<input type="checkbox"/>
	N/A	<input type="checkbox"/>
Band Selection	Software	<input type="checkbox"/>
	Duplexer	<input checked="" type="checkbox"/>
	Full band	<input type="checkbox"/>

Additional equipment for test*	
Remote Unit 1	FCC ID: BCR-TFAHR4E
Romote Unit 2	FCC ID: BCR-TFAHR4E

*see 2.1.4

2.1.1 Downlink

Pass band	2350 MHz – 2360 MHz
Max. composite output power based on one carrier per path (rated)	31 dBm = 1.3 W
MIMO max. composite output power based on one carrier per path (rated)	34 dBm = 2.5 W
System Gain**	-2 dB @ Pout BTS of 33 dBm

**see 2.1.5

2.1.2 Uplink

Pass band	2305 MHz – 2315 MHz
System Gain**	n. a.

**see 2.1.5

Note: The EUT does not transmit over the air in the uplink direction.



2.1.3 Description of EUT

CommScope's ION-U EB L 23/23 is a LTE MIMO multi-operator Extension Unit. It is used in conjunction with a Remote Unit in the ION optical distribution system. This system transports multiple LTE channels simultaneously, providing a cost-effective solution for distributing capacity from one or more base stations.

This Test Report describes only the approval of the 2300 MHz Main Path. The ION-U EB L 23/23 Repeater system consists of two 2300 MHz path with the intended use of simultaneous transmission.

The antenna(s) used with device must be fixed-mounted on permanent structures.

2.1.4 Block diagram of measurement reference points

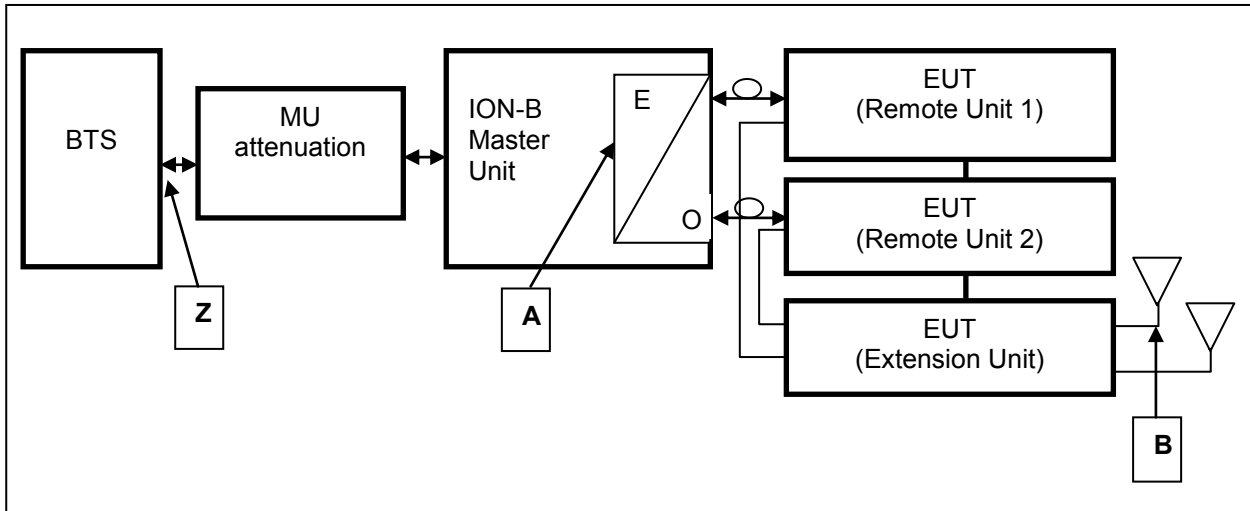

figure 2.1.4-#1 Block diagram of measurement reference points

Extension Unit (EU) is the EUT

O/E Optical / Electrical converter
 MU Master Unit

Reference point A	MU	UL output,	DL input
Reference point B	Extension Unit	DL output,	UL input
Reference point Z	BTS	DL output,	UL input

Since a signal generator does not supply a good output signal with +33 or +43dBm, for the downlink measurement the MU Attenuation is not used. That means for downlink measurements the signal generator is connected to measurement point A at the master optical / electrical converter and the analyzer to the measurement point B at the RU.

The EUT was tested with the worst case configuration (MIMO), where the highest interferers to be expected.



2.1.5 Downlink System Gain and Output Power

System optimized for BTS power (fixed value) Z	MU Attenuation (manual leveling)	Maximum rated input power at the MU OTRX (fixed value) A	RU Gain (fixed value) A to B	Maximum rated output power at RU Antenna port (fixed value) B
+33 dBm	37 dB	-4 dBm	+35 dB	+31.0 dBm <i>@ 1 carrier</i>
System Gain Z to B	-2 dB			
+43 dBm	47 dB	-4 dBm	+35 dB	+31.0 dBm <i>@ 1 carrier</i>
System Gain Z to B	-12 dB			

table 2.1.5-#1 Equipment under test (E.U.T.) Description Downlink System Gain and Output Power



3 Test site (Andrew Buchdorf)

3.1 Test environment

All tests were performed under the following environmental conditions:

Condition	Minimum value	Maximum value
Barometric pressure	86 kPa	106 kPa
Temperature	15°C	30°C
Relative Humidity	20 %	75 %
Power supply range	±5% of rated voltages	

3.2 Test equipment

ANDREW Inv. No.	Test equipment	Type	Manufacturer	Serial No.	Calibration
9266	Network Analyzer	ZNB 20	R&S	101490	12/2014
9126	Spectrum Analyzer	FSV 30	R&S	101237	11/2014
9069	Generator	SMBV100A	R&S	256275	08/2014
9046	Generator	SMBV100A	R&S	255090	05/2015
8542	Power Meter	E4418A	Agilent	GB38273230	01/2015
8544	Power Sensor	E8481H	Agilent	3318A19208	01/2015
7157	RF-Cable	Succoflex	Suhner	36180/4P	CIU
7158	RF-Cable	Succoflex	Suhner	36182/4P	CIU
7289	RF-Cable	Succoflex	Suhner	28443/4PE	CIU
7290	RF-Cable	Succoflex	Suhner	28444/4PE	CIU
7385	RF-Cable	Succoflex	Suhner	36267/4P	CIU
7387	RF-Cable	Succoflex	Suhner	36267/4P	CIU
7390	RF-Cable	Succoflex	Suhner	40193/4P	CIU
7381	RF-Cable	Succoflex	Suhner	40200/4P	CIU
7406	Matrix		Andrew		CIU

CIU = Calibrate in use



3.3 Input and output losses

All recorded power levels should be referenced to the input and output connectors of the repeater, unless explicitly stated otherwise.

The test equipment used in this test has to be calibrated, so that the functionality is also checked.

All cables, attenuators, splitter, isolator, circulator and combiner etc. must be measured before testing and used for compensation during testing.

3.4 Measurement uncertainty

The extended measurement uncertainty corresponds to the measurement results from the standard measurement uncertainty multiplied by the coverage factor $k=2$. The true value is located in the corresponding interval with a probability of 95 %.

4 Test site (Bureau Veritas Consumer Products Services)

FCC Test site: **96997**
IC OATS: **IC3475A-1**

See relevant dates under section 9 of this test report.

5 RF Power Out: §27.50, §2.1046

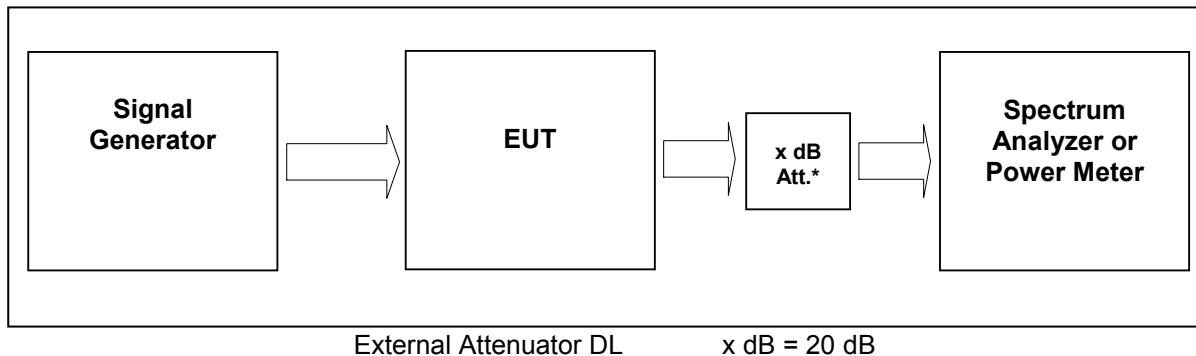

figure 5-#1 Test setup: RF Power Out: §27.50, §2.1046

Measurement uncertainty	± 0,38 dB
Test equipment used	9069, 9046, 9126, 7406

5.1 Limit

Minimum standard:
Para. No.27.50(a)

(a) The following power limits and related requirements apply to stations transmitting in the 2305-2320 MHz band or the 2345-2360 MHz band.

(1) *Base and fixed stations.* (i) For base and fixed stations transmitting in the 2305-2315 MHz band or the 2350-2360 MHz band:

(A) The average equivalent isotropically radiated power (EIRP) must not exceed 2,000 watts within any 5 megahertz of authorized bandwidth and must not exceed 400 watts within any 1 megahertz of authorized bandwidth.

(B) The peak-to-average power ratio (PAPR) of the transmitter output power must not exceed 13 dB. The PAPR measurements should be made using either an instrument with complementary cumulative distribution function (CCDF) capabilities to determine that PAPR will not exceed 13 dB for more than 0.1 percent of the time or other Commission approved procedure. The measurement must be performed using a signal corresponding to the highest PAPR expected during periods of continuous transmission.

(ii) For base and fixed stations transmitting in the 2315-2320 MHz band or the 2345-2350 MHz band, the peak EIRP must not exceed 2,000 watts.

5.2 Test method

§ 2.1046 Measurements required: RF power output.

(a) For transmitters other than single sideband, independent sideband and controlled carrier radiotelephone, power output shall be measured at the RF output terminals when the transmitter is adjusted in accordance with the tune-up procedure to give the values of current and voltage on the circuit elements specified in § 2.1033(c)(8). The electrical characteristics of the radio frequency load attached to the output terminals when this test is made shall be stated.



(c) For measurements conducted pursuant to paragraphs (a) and (b) of this section, all calculations and methods used by the applicant for determining carrier power or peak envelope power, as appropriate, on the basis of measured power in the radio frequency load attached to the transmitter output terminals shall be shown. Under the test conditions specified, no components of the emission spectrum shall exceed the limits specified in the applicable rule parts as necessary for meeting occupied bandwidth or emission limitations

5.3 Test Results

Detector RMS.

Test signal LTE:

Signal waveform according to Test Model 1.1, E-TM1.1, clause 6.1.1.1-1, table 6.1.1.1-1 of standard specification 3GPP TS 36.141 V9.3.0 (2010-03).

5.3.1 Downlink

Modulation	Measured at	F / MHz	RBW VBW Span	Crest (dB)	RF Power (dBm)	RF Power (W)	MIMO RF Power (W)	Plot -
LTE 5 MHz	Middle	2355 MHz	100kHz 300kHz 20MHz	8.13	31.0	1.3	2.5	5.3.1.1 #1
LTE 10 MHz	Middle	2355 MHz	100kHz 300kHz 20MHz	8.68	31.0	1.3	2.5	5.3.1.2 #1
Maximum output power = 31 dBm = 1.3 W								
Limit Maximum output power (eirp) = 2000 W / 5MHz (400 W / 1MHz)								

table 5.3.1-#1 RF Power Out: §27.50, §2.1046 Test Results Downlink

The max RF Power out is 33 dBm, so the maximum antenna gain (x) can be calculated as follow:

Limit = 2000W (eirp) = 63 dBm

Info: eirp = erp * 1.64

63 dBm > 31 dBm + x -----> x = 63 dBm – 31 dBm = 32 dBd

=> The antenna that will be used for the complete system have to have a gain lower than 32 dBd, relative to a dipol.



MIMO:

The MIMO max RF Power out is 34 dBm, so the maximum antenna gain (x) can be calculated as follow:

Limit = 2000W (eirp) = 63 dBm

Info: eirp = erp * 1.64

$$63 \text{ dBm} > 34 \text{ dBm} + x \quad \text{----->} \quad x = 63 \text{ dBm} - 34 \text{ dBm} = \underline{29 \text{ dBd}}$$

=> The antenna that will be used for the complete system have to have a gain lower than 18 dBi, relative to a dipol.

Modulation	Pin / dBm (Ref. point A)
LTE 5 MHz signal	-4.0
LTE 10 MHz signal	-3.9

table 5.3.1-#2 RF Power Out: §27.50, §2.1046 Test Results Downlink Input power



5.3.1.1 LTE; 5 MHz signal

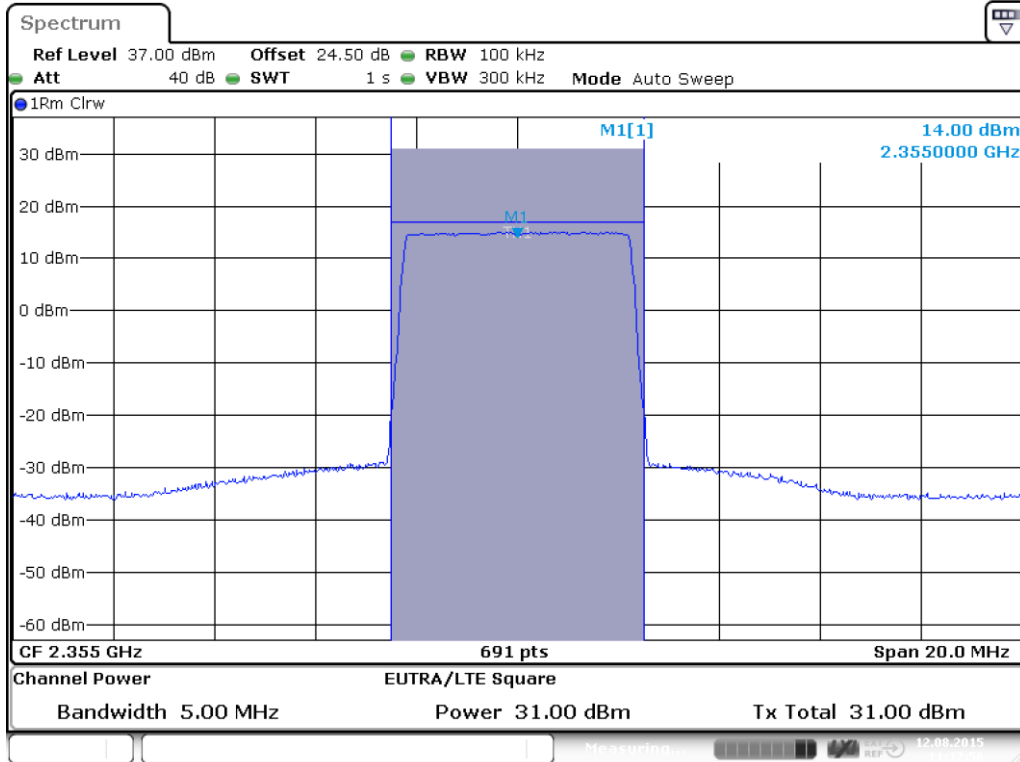

Date: 12.AUG.2015 11:37:56

plot 5.3.1.1-#1 RF Power Out: §27.50, §2.1046; Downlink; LTE; 5 MHz signal Middle

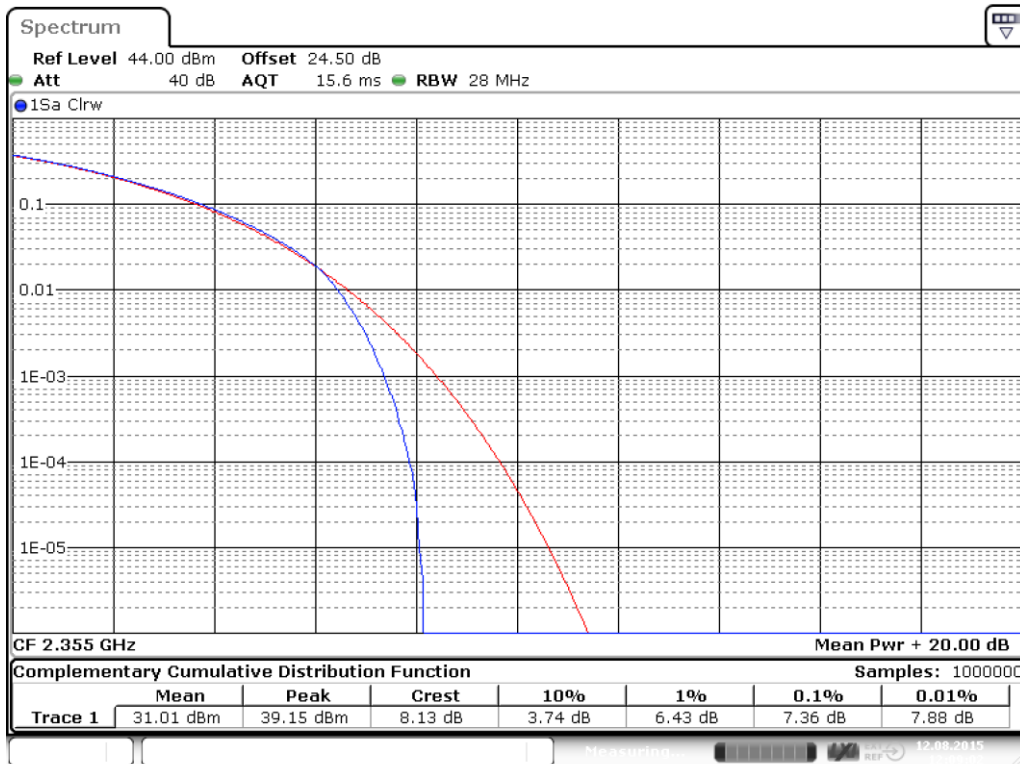

Date: 12.AUG.2015 12:09:03

plot 5.3.1.1-#2 RF Power Out: §27.50, §2.1046; Downlink; LTE; 5 MHz signal Middle; CCDF



5.3.1.2 LTE; 10 MHz signal

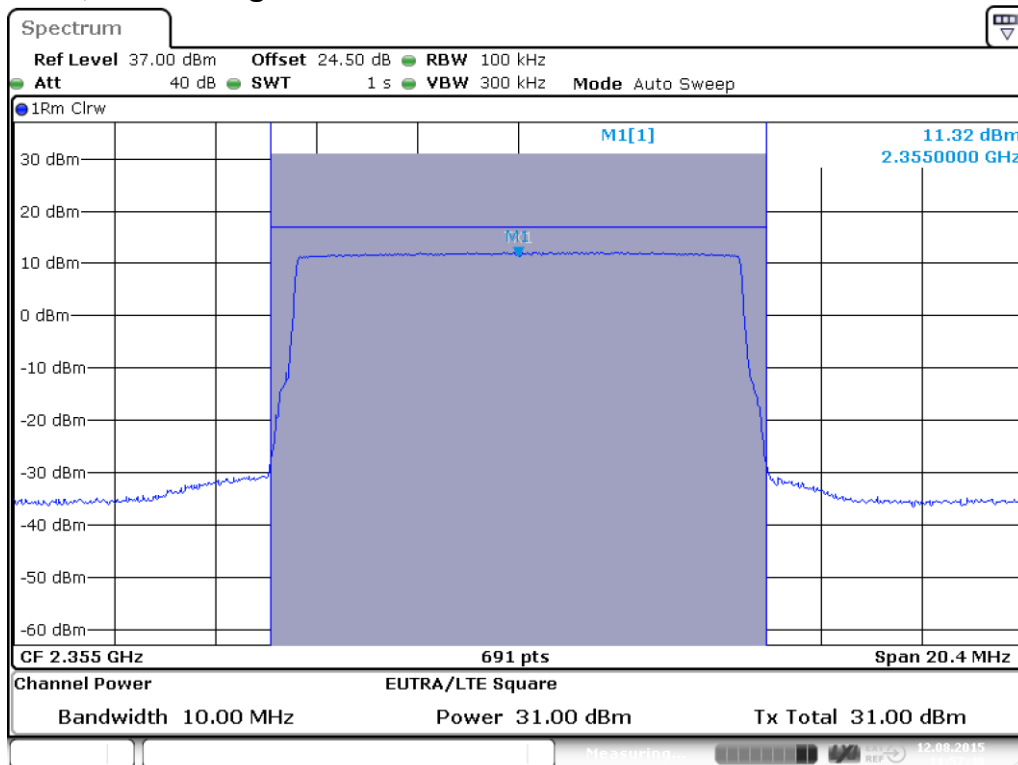

plot 5.3.1.2-#1 RF Power Out: §27.50, §2.1046; Downlink; LTE; 10 MHz signal Middle

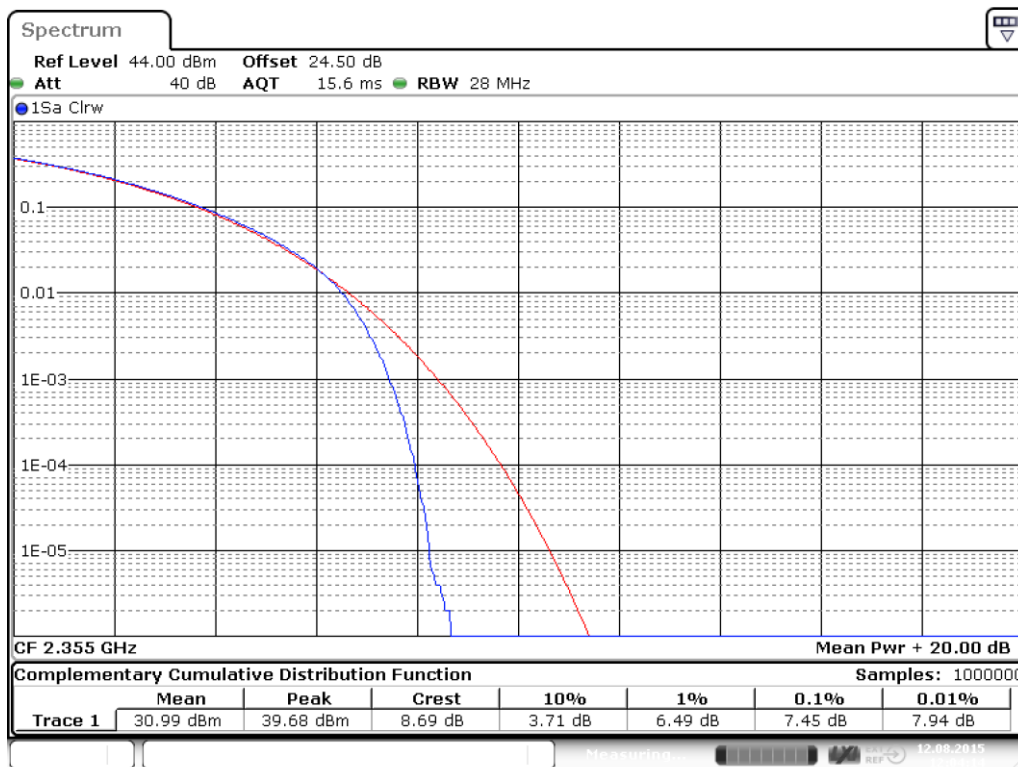

plot 5.3.1.2-#2 RF Power Out: §27.50, §2.1046; Downlink; LTE; 10 MHz signal Middle; CCDF



5.3.2 Uplink

n.a.

Note: The EUT does not transmit over the air in the uplink direction.

5.4 Summary test result

Test result	complies, according the plots above
Tested by:	F. Bengesser
Date:	12.08.2015



6 Occupied Bandwidth: §2.1049

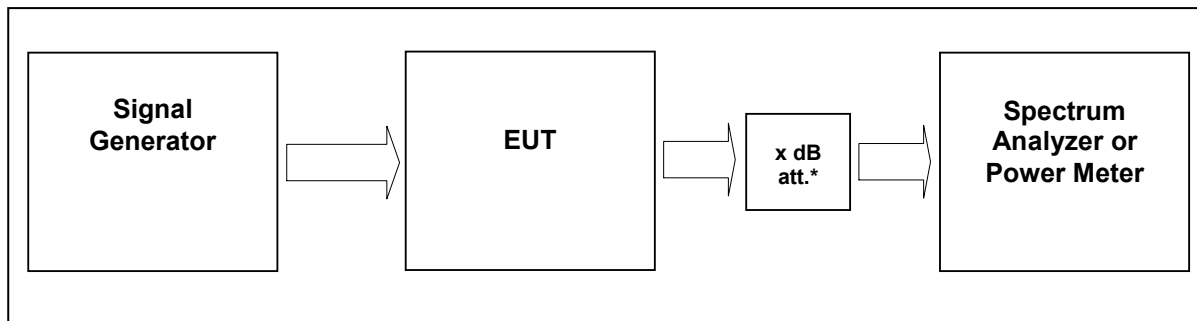

External Attenuator DL x dB = 20 dB
 figure 6-#1 Test setup: Occupied Bandwidth: §2.1049

Measurement uncertainty	± 0,38 dB
Test equipment used	9069, 9126, 7406

6.1 Limit

The spectral shape of the output should look similar to input for all modulations.

6.2 Test method

Para. No.2.1049

The occupied bandwidth, that is the frequency bandwidth such that, below its lower and above its upper frequency limits, the mean powers radiated are each equal to 0.5 percent of the total mean power radiated by a given emission shall be measured under the following conditions as applicable:

6.3 Test results

6.3.1 Downlink

Detector PK.

Modulation	Measured at	F / MHz	RBW VBW Span	Occupied Bandwidth / MHz	Plot #
LTE 5 MHz	Middle	2355	100 kHz 200 kHz 15 MHz	4.515	6.3.1.1 #1, #2
LTE 10 MHz	Middle	2355	200 kHz 300 kHz 30 MHz	9.03	6.3.1.3 #1, #2



Modulation	Measured at	F / MHz	RBW VBW Span	26dB Bandwidth / MHz	Plot #
LTE 5 MHz	Middle	2355	100 kHz 200 kHz 15 MHz	5.036	6.3.1.2 #1, #2
LTE 10 MHz	Middle	2355	200 kHz 300 kHz 30 MHz	9.986	6.3.1.4 #1, #2

table 6.3-#1 Occupied Bandwidth: §2.1049 Test results



6.3.1.1 LTE; 5 MHz signal; OBW 99%

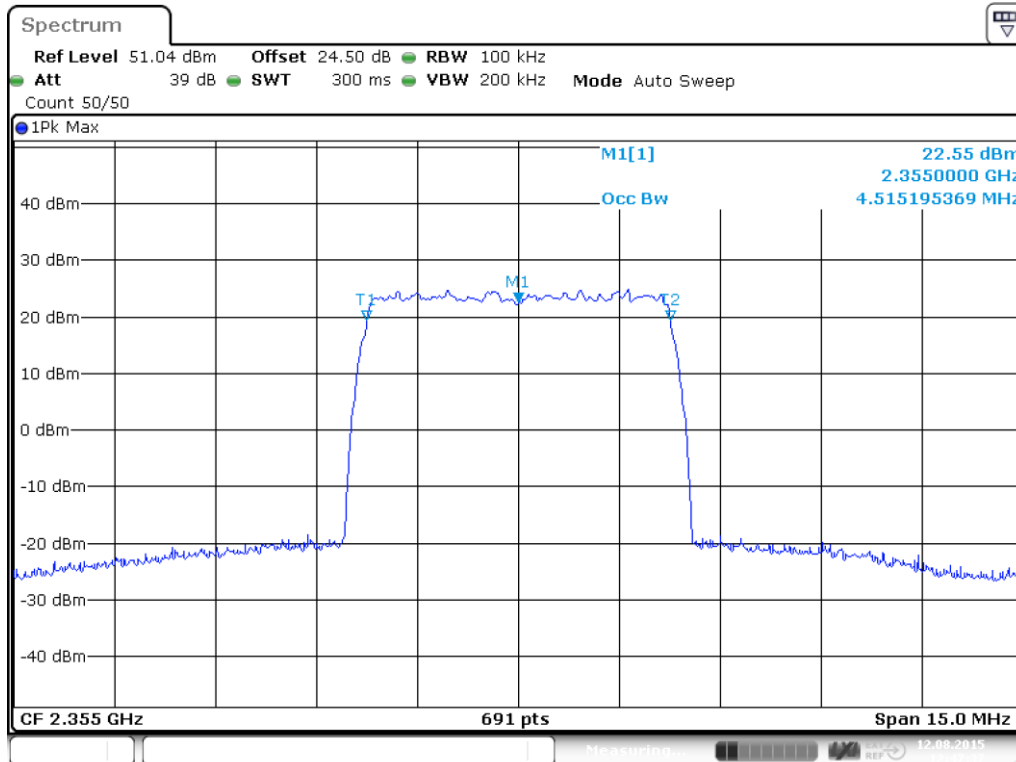

Date: 12.AUG.2015 12:47:37

plot 6.3.1.1-#1 Occupied Bandwidth: \$2.1049; Test results; Downlink; LTE; 5 MHz signal; OBW 99% Output

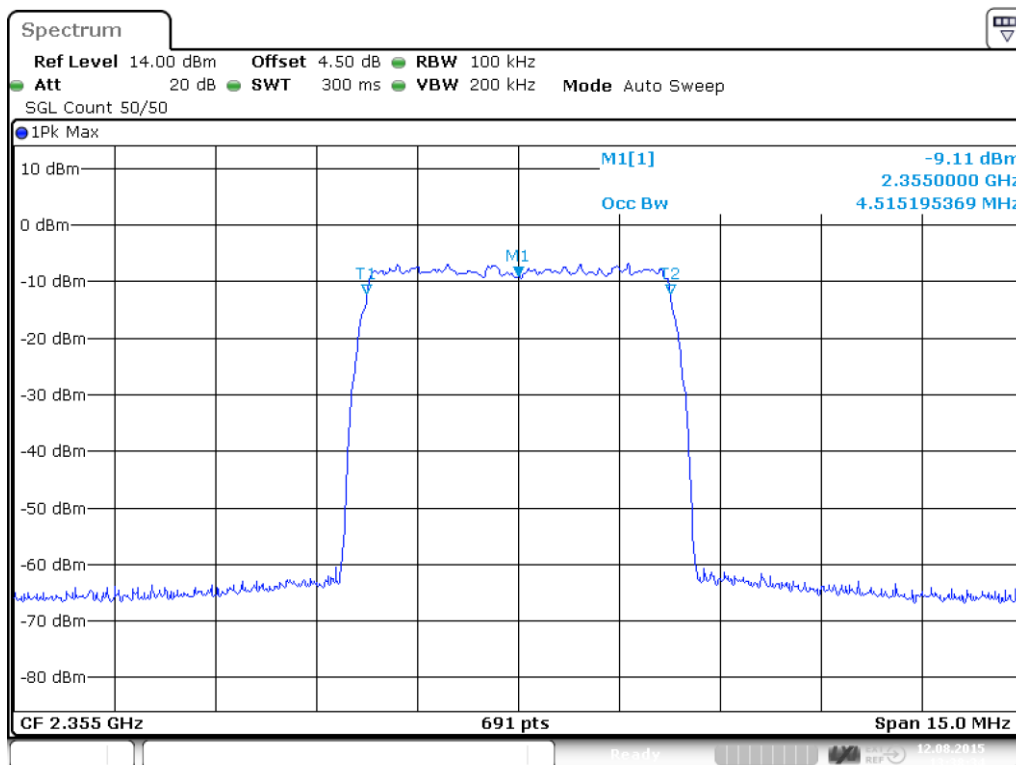

Date: 12.AUG.2015 13:38:34

plot 6.3.1.1-#2 Occupied Bandwidth: \$2.1049; Test results; Downlink; LTE; 5 MHz signal; OBW 99% Input



6.3.1.2 LTE; 5 MHz signal; OBW 26dB

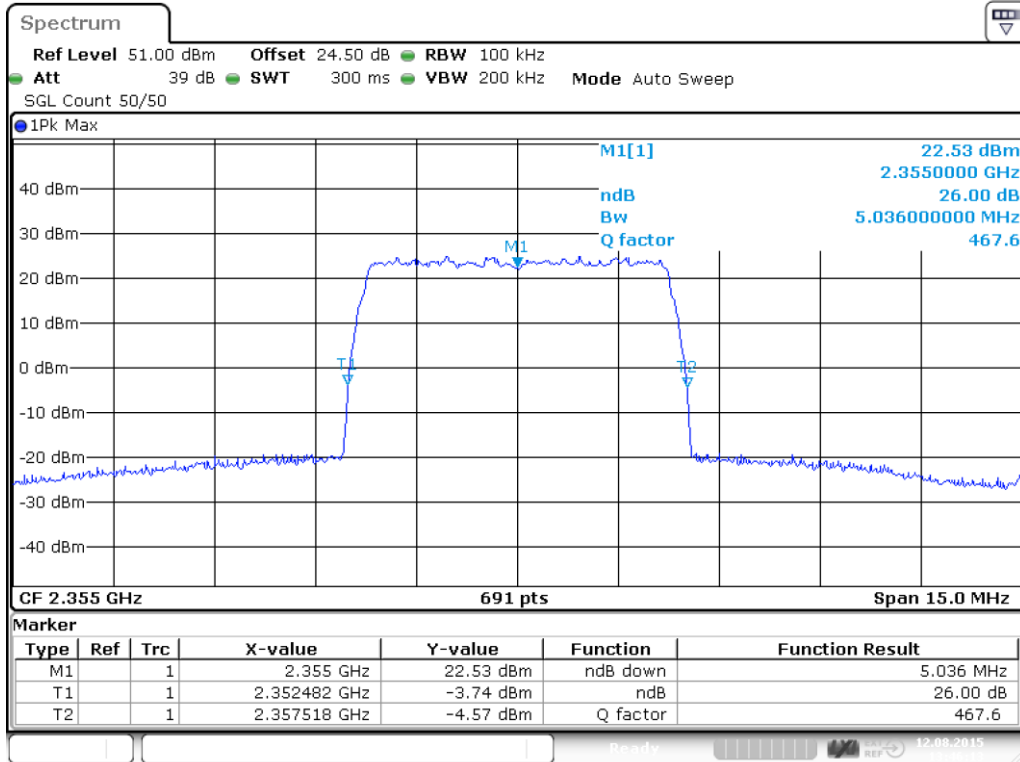

plot 6.3.1.2-#1 Occupied Bandwidth: §2.1049; Test results; Downlink; LTE; 5 MHz signal; OBW 26dB Output

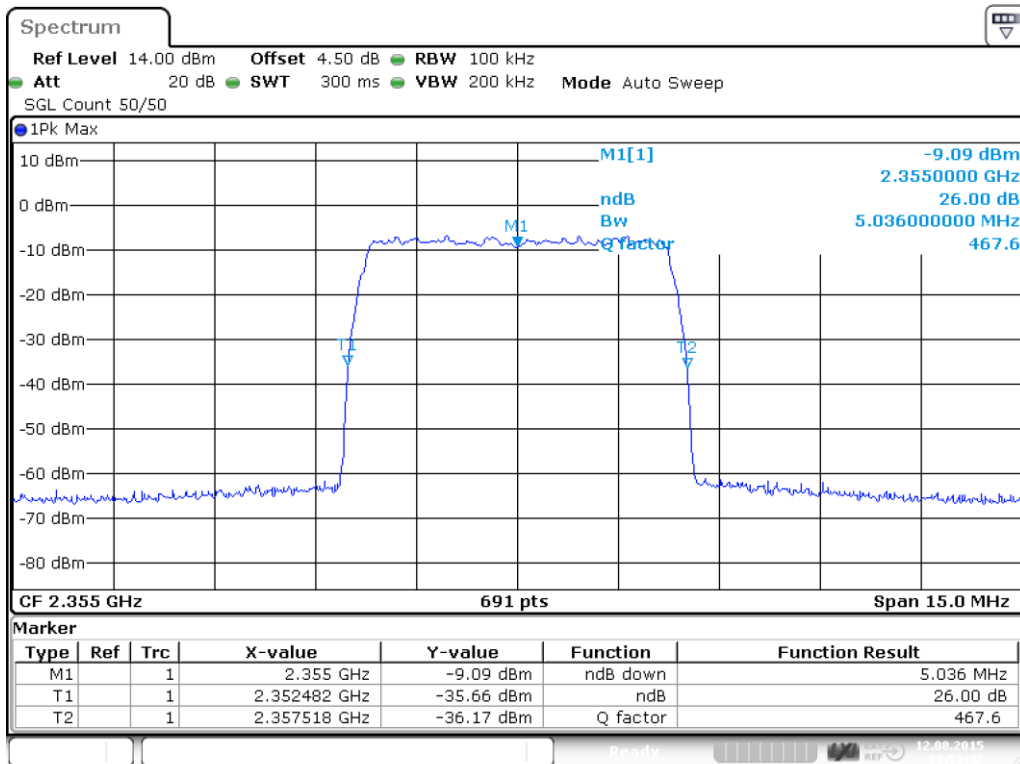

plot 6.3.1.2-#2 Occupied Bandwidth: §2.1049; Test results; Downlink; LTE; 5 MHz signal; OBW 26dB Input



6.3.1.3 LTE; 10 MHz signal; OBW 99%

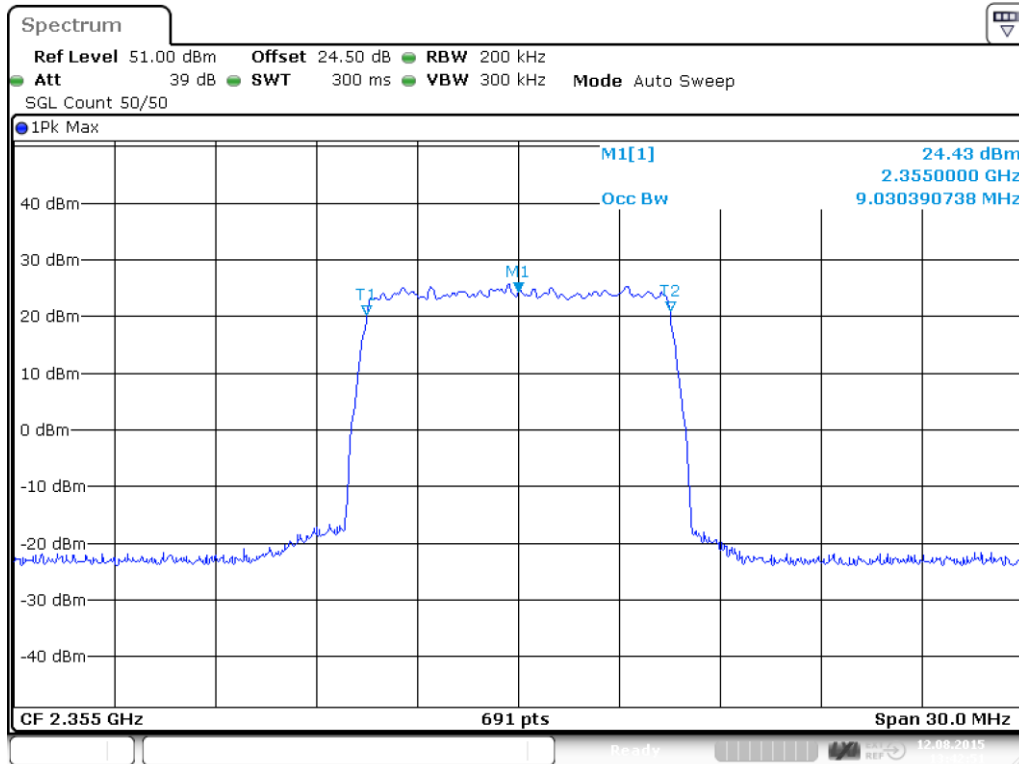

plot 6.3.1.3-#1 Occupied Bandwidth: §2.1049; Test results; Downlink; LTE; 10 MHz signal; OBW 99% Output

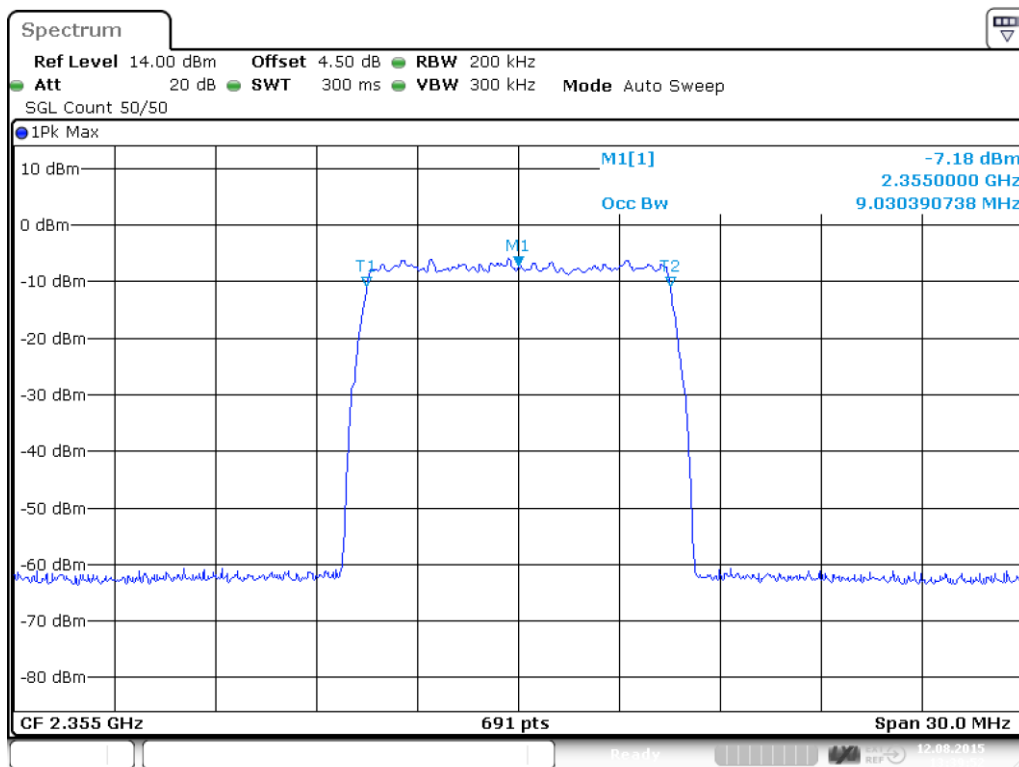

plot 6.3.1.3-#2 Occupied Bandwidth: §2.1049; Test results; Downlink; LTE; 10 MHz signal; OBW 99% Input



6.3.1.4 LTE; 10 MHz signal; OBW 26dB

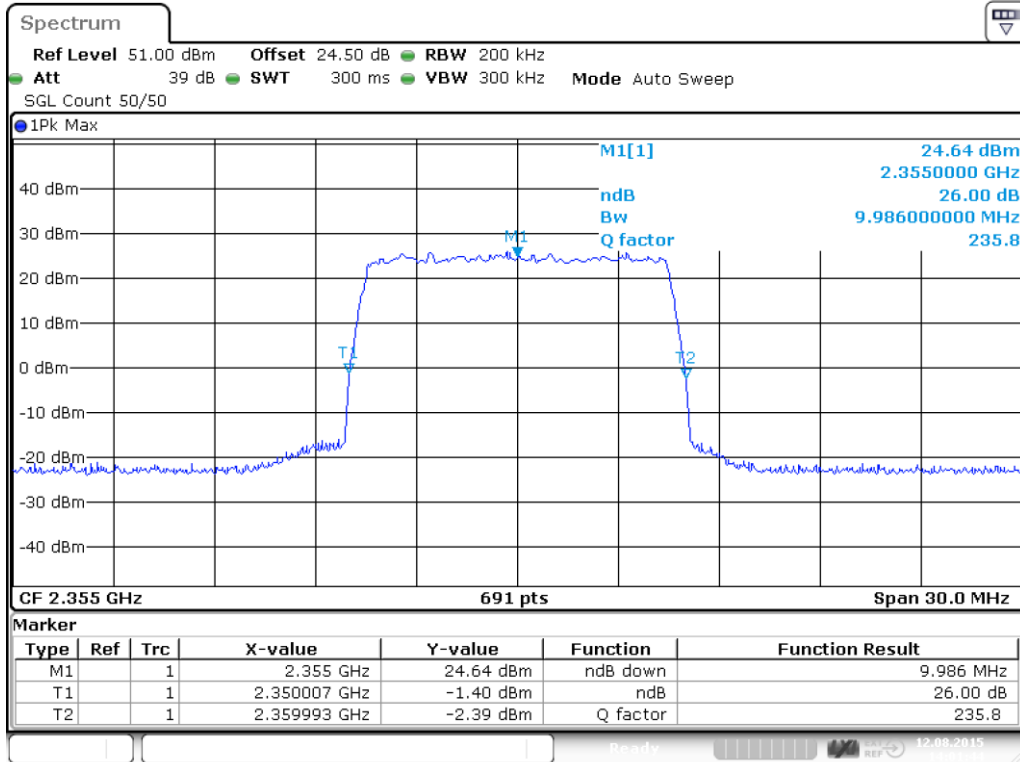

plot 6.3.1.4-#1 Occupied Bandwidth: \$2.1049; Test results; Downlink; LTE; 10 MHz signal; OBW 26dB Output

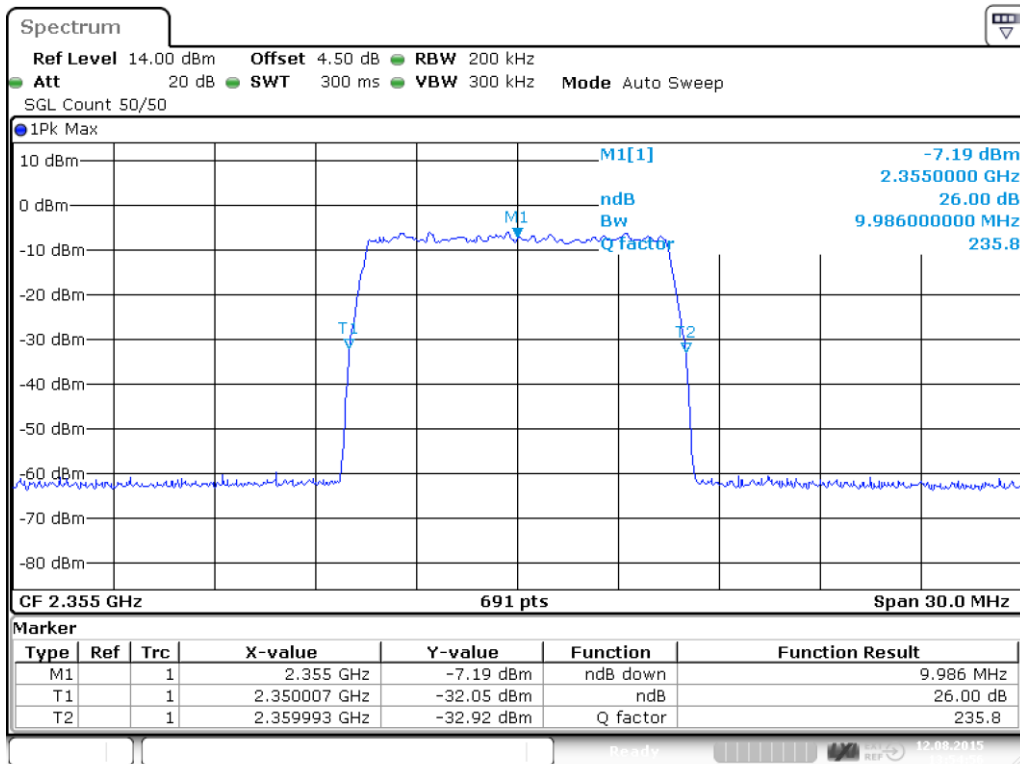

plot 6.3.1.4-#2 Occupied Bandwidth: \$2.1049; Test results; Downlink; LTE; 10 MHz signal; OBW 26dB Input



6.3.2 Uplink

n.a.

Note: The EUT does not transmit over the air in the uplink direction.

6.4 Summary test result

Test result	complies, according the plots above
Tested by:	F. Bengesser
Date:	12.08.2015

7 Spurious Emissions at Antenna Terminals: §27.53, §2.1051

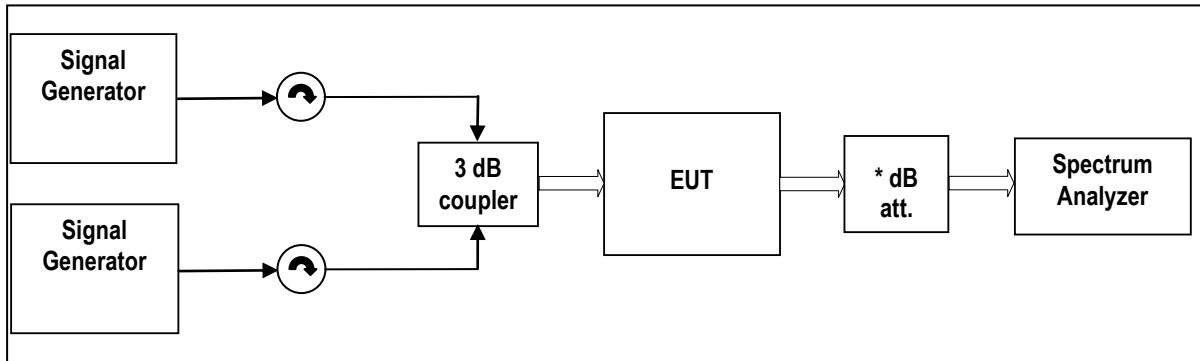

External Attenuator DL x dB = 20 dB

figure 7-#1 Test setup: Spurious Emissions at Antenna Terminals: §27.53, §2.1051

Measurement uncertainty	± 0,54 dB ± 1,2 dB ± 1,5 dB	9 kHz to 3 GHz 3 GHz to 7 GHz 7 GHz to 26 GHz
Test equipment used	9069, 9046, 9126, 7406	

7.1 Limit

(a) For operations in the 2305-2320 MHz band and the 2345-2360 MHz band, the power of any emission outside a licensee's frequency band(s) of operation shall be attenuated below the transmitter power P (with averaging performed only during periods of transmission) within the licensed band(s) of operation, in watts, by the following amounts:

(1) For base and fixed stations' operations in the 2305-2320 MHz band and the 2345-2360 MHz band:

(i) By a factor of not less than $43 + 10 \log (P)$ dB on all frequencies between 2305 and 2320 MHz and on all frequencies between 2345 and 2360 MHz that are outside the licensed band(s) of operation, and not less than $75 + 10 \log (P)$ dB on all frequencies between 2320 and 2345 MHz;

(ii) By a factor of not less than $43 + 10 \log (P)$ dB on all frequencies between 2300 and 2305 MHz, $70 + 10 \log (P)$ dB on all frequencies between 2287.5 and 2300 MHz, $72 + 10 \log (P)$ dB on all frequencies between 2285 and 2287.5 MHz, and $75 + 10 \log (P)$ dB below 2285 MHz;

(iii) By a factor of not less than $43 + 10 \log (P)$ dB on all frequencies between 2360 and 2362.5 MHz, $55 + 10 \log (P)$ dB on all frequencies between 2362.5 and 2365 MHz, $70 + 10 \log (P)$ dB on all frequencies between 2365 and 2367.5 MHz, $72 + 10 \log (P)$ dB on all frequencies between 2367.5 and 2370 MHz, and $75 + 10 \log (P)$ dB above 2370 MHz.

(2) For fixed customer premises equipment (CPE) stations operating in the 2305-2320 MHz band and the 2345-2360 MHz band transmitting with more than 2 watts per 5 megahertz average EIRP:

(i) By a factor of not less than $43 + 10 \log (P)$ dB on all frequencies between 2305 and 2320 MHz and on all frequencies between 2345 and 2360 MHz that are outside the licensed band(s) of operation, and not less than $75 + 10 \log (P)$ dB on all frequencies between 2320 and 2345 MHz;

(ii) By a factor of not less than $43 + 10 \log (P)$ dB on all frequencies between 2300 and 2305 MHz, $70 + 10 \log (P)$ dB on all frequencies between 2287.5 and 2300 MHz, $72 + 10 \log (P)$ dB on all frequencies between 2285 and 2287.5 MHz, and $75 + 10 \log (P)$ dB below 2285 MHz;



(iii) By a factor of not less than $43 + 10 \log (P)$ dB on all frequencies between 2360 and 2362.5 MHz, $55 + 10 \log (P)$ dB on all frequencies between 2362.5 and 2365 MHz, $70 + 10 \log (P)$ dB on all frequencies between 2365 and 2367.5 MHz, $72 + 10 \log (P)$ dB on all frequencies between 2367.5 and 2370 MHz, and $75 + 10 \log (P)$ dB above 2370 MHz.

If the DUT used in MIMO configuration according to KDB 662911, the summed emission (MIMO Max. Level) is calculated (Max. Level) of the output port plus $10 \log (N_{ANT})$. With $(N_{ANT} = 2)$ the MIMO Max. Level (dBm) equals Max. Level (dBm) plus 3dB.

7.2 Test method

Para. No 2.1051 Measurements required: Spurious emissions at antenna terminals. The radio frequency voltage or powers generated within the equipment and appearing on a spurious frequency shall be checked at the equipment output terminals when properly loaded with a suitable artificial antenna. Curves or equivalent data shall show the magnitude of each harmonic and other spurious emission that can be detected when the equipment is operated under the conditions specified in § 2.1049 as appropriate. The magnitude of spurious emissions which are attenuated more than 20 dB below the permissible value need not be specified.

[39 FR 5919, Feb. 15, 1974. Redesignated and amended at 63 FR 36599, July 7, 1998]

7.3 Test results

7.3.1 Downlink

Detector: RMS.

Modulation	Carrier(s) F / MHz	Limit pass/fail	Limit with MIMO pass/fail	Plot -
2 x LTE 5 MHz	2352.5 2357.5	pass	pass	7.3.1.1 1 - 6
LTE 10 MHz	2355	pass	pass	7.3.1.2 1 - 6

table 7.3-#1 Spurious Emissions at Antenna Terminals: §27.53, §2.1051 Test results



7.3.1.1 LTE; 2 x 5 MHz signal

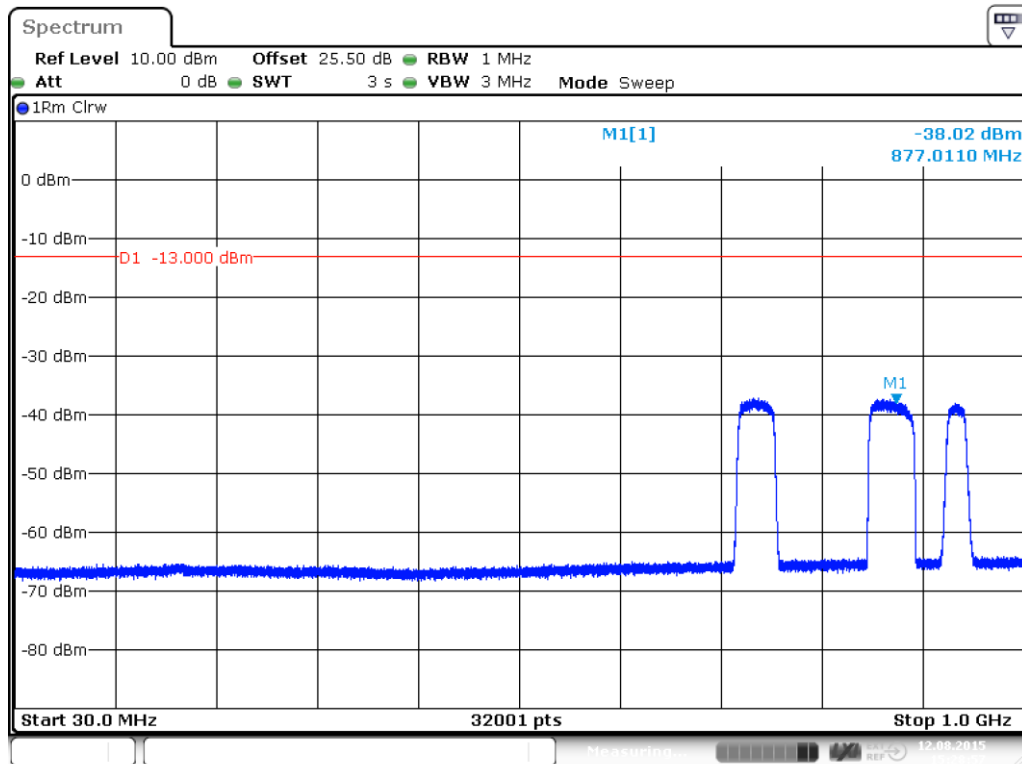

Date: 12.AUG.2015 15:28:57

plot 7.3.1.1-#1 Spurious Emissions at Antenna Terminals: §27.53, §2.1051; Test results; Downlink; LTE; 2 x 5 MHz signal; 30 MHz – 1 GHz; carrier notched

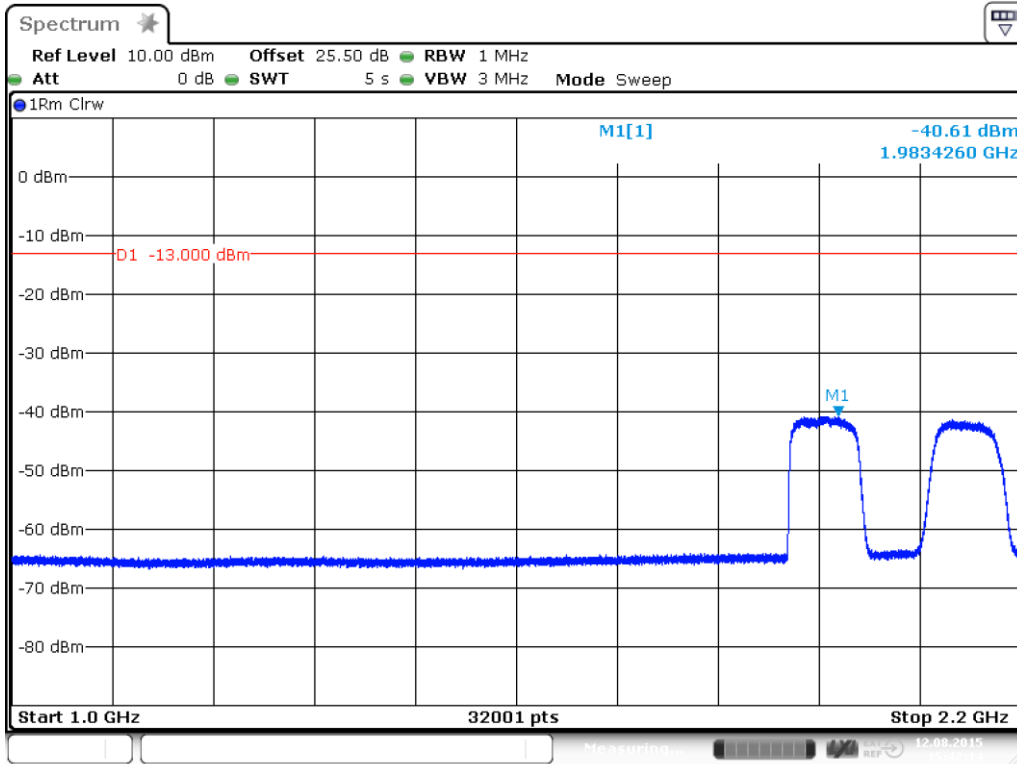

Date: 12.AUG.2015 15:42:14

plot 7.3.1.1-#2 Spurious Emissions at Antenna Terminals: §27.53, §2.1051; Test results; Downlink; LTE; 2 x 5 MHz signal; 1 GHz – 2.2 GHz; carrier notched

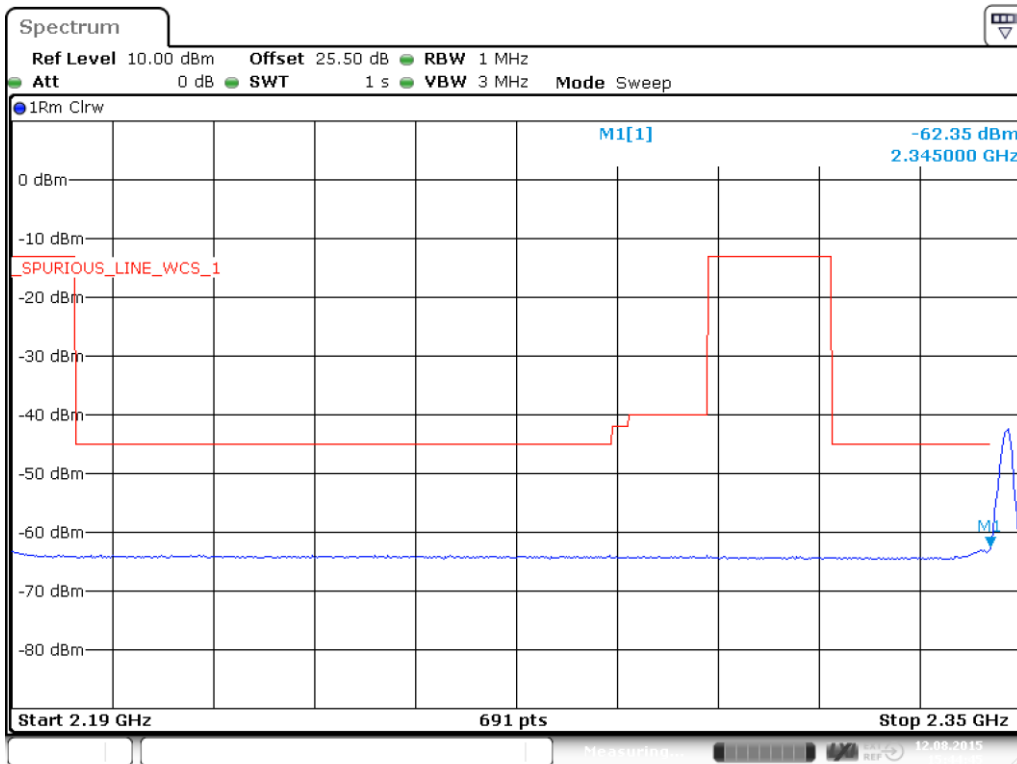

Date: 12.AUG.2015 15:44:46

plot 7.3.1.1-#3 Spurious Emissions at Antenna Terminals: §27.53, §2.1051; Test results; Downlink; LTE; 2 x 5 MHz signal; 2.19 GHz – 2.35 GHz; carrier notched

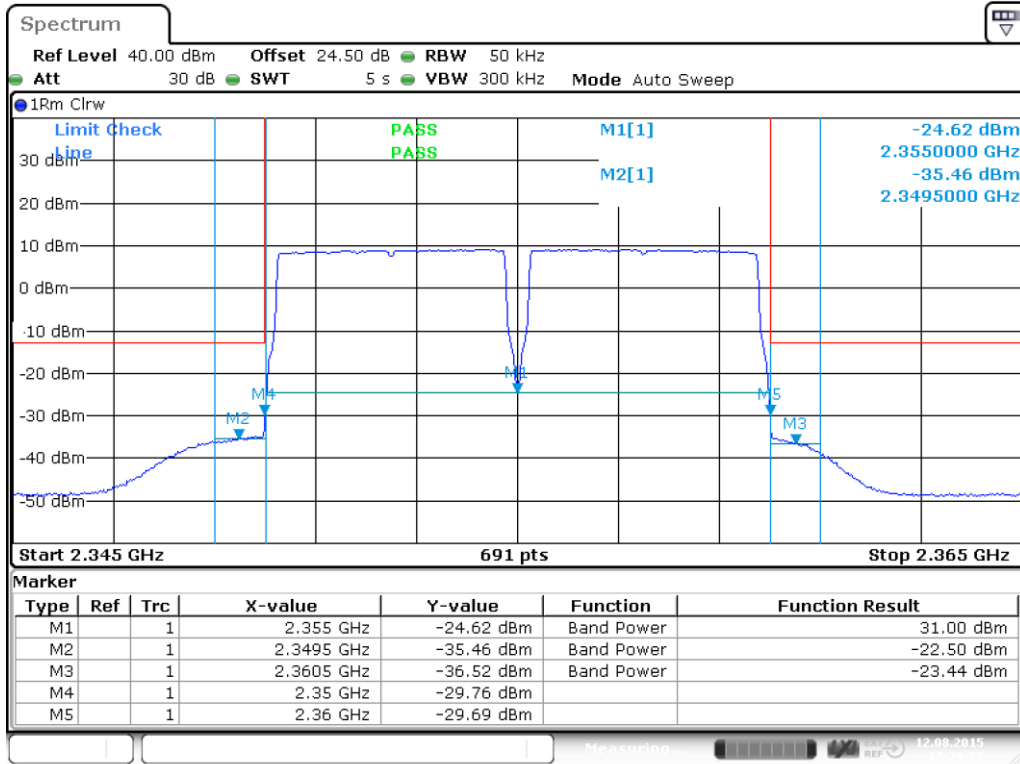

Date: 12.AUG.2015 12:20:28

plot 7.3.1.1-#4 Spurious Emissions at Antenna Terminals: §27.53, §2.1051; Test results; Downlink; LTE; 2 x 5 MHz signal; 2.345 GHz – 2.365 GHz

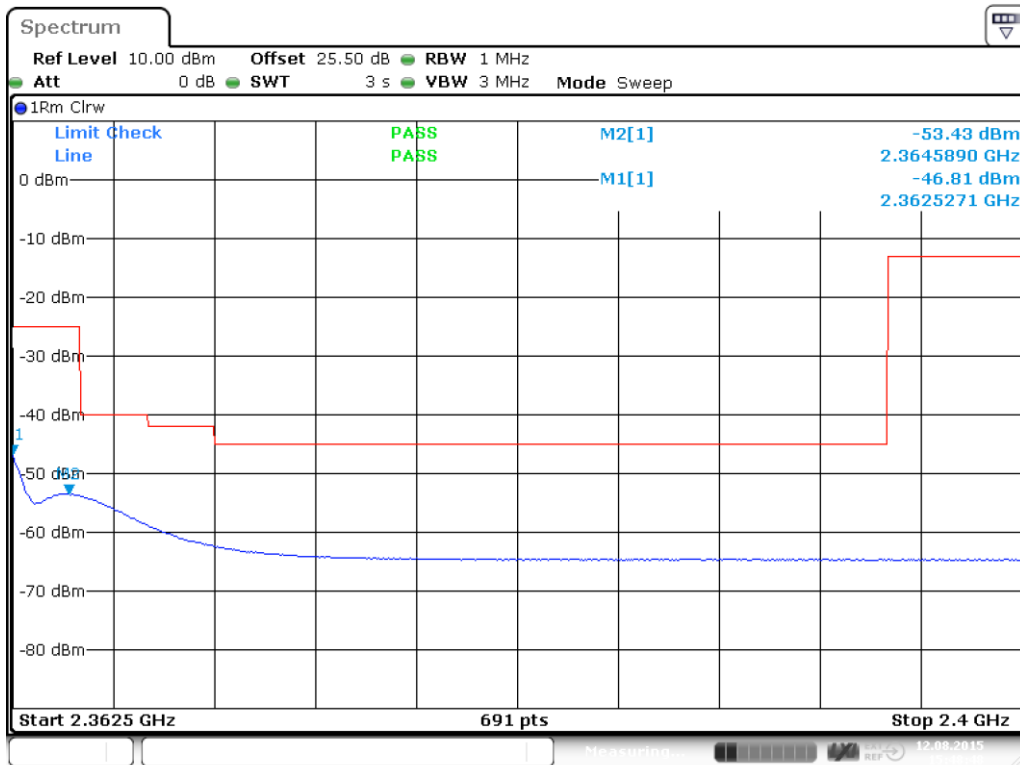

Date: 12.AUG.2015 15:48:49

plot 7.3.1.1-#5 Spurious Emissions at Antenna Terminals: §27.53, §2.1051; Test results; Downlink; LTE; 2 x 5 MHz signal; 2.3625 GHz – 2.4 GHz; carrier notched

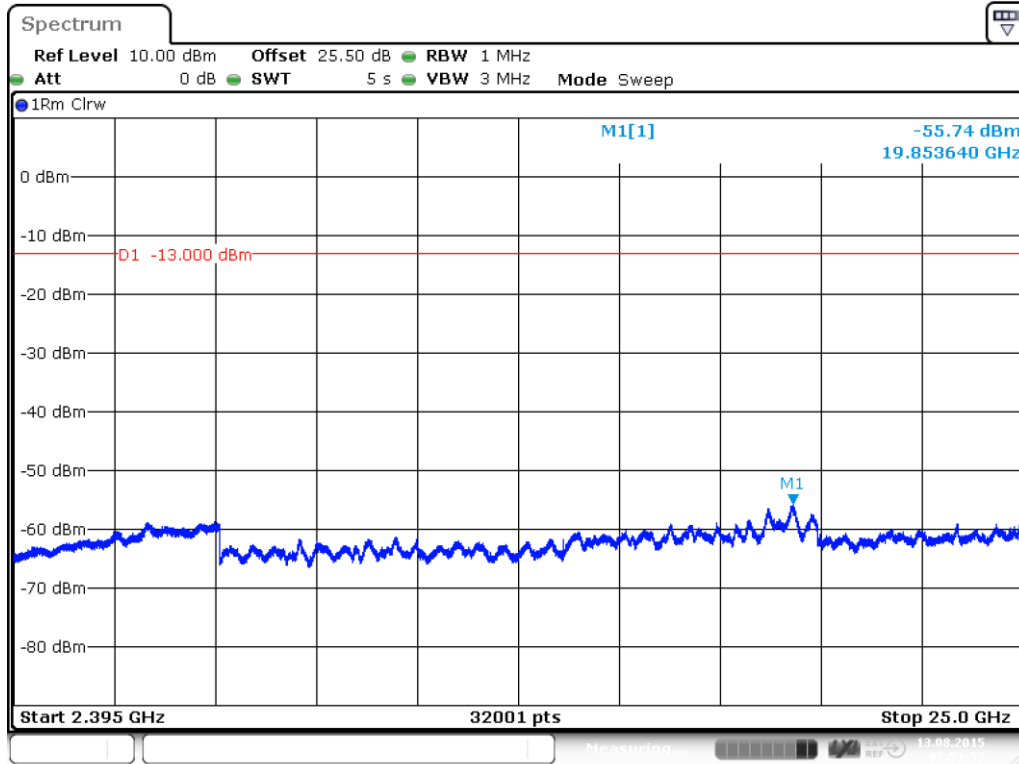

Date: 13.AUG.2015 07:51:57

plot 7.3.1.1-#6 Spurious Emissions at Antenna Terminals: §27.53, §2.1051; Test results; Downlink; LTE; 2 x 5 MHz signal; 2.395 GHz – 25 GHz; carrier notched

7.3.1.2 LTE; 10 MHz signal

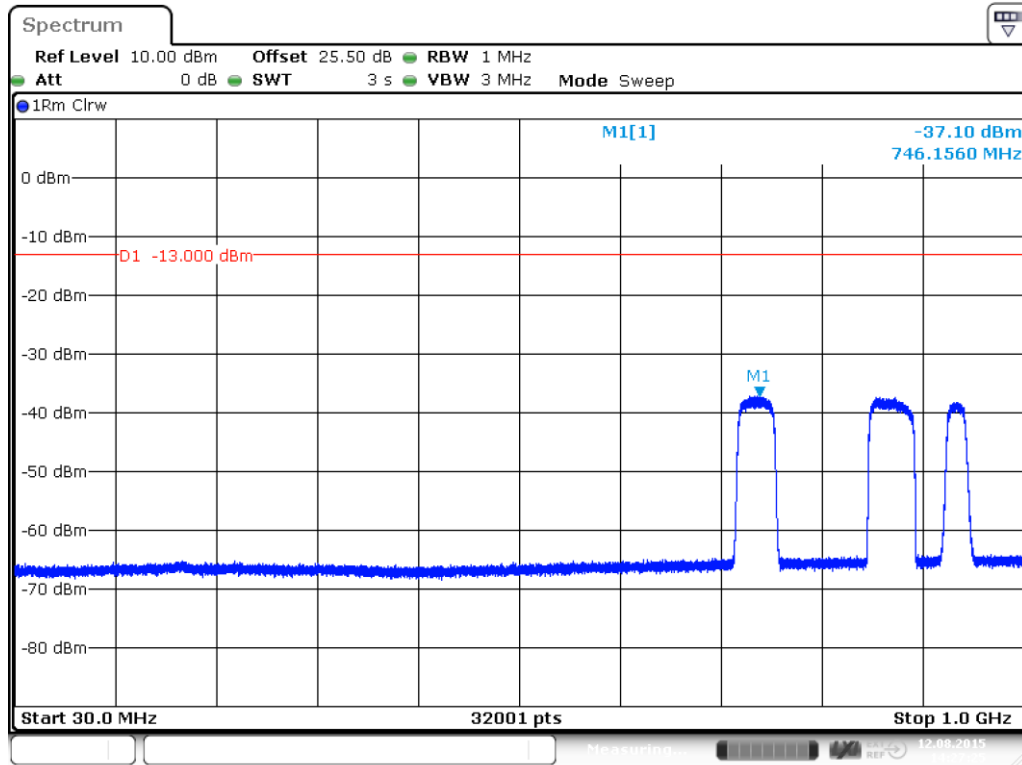

Date: 12.AUG.2015 14:27:26

plot 7.3.1.2-#1 Spurious Emissions at Antenna Terminals: §27.53, §2.1051; Test results; Downlink; LTE; 10 MHz signal; 30 MHz – 1 GHz; carrier notched

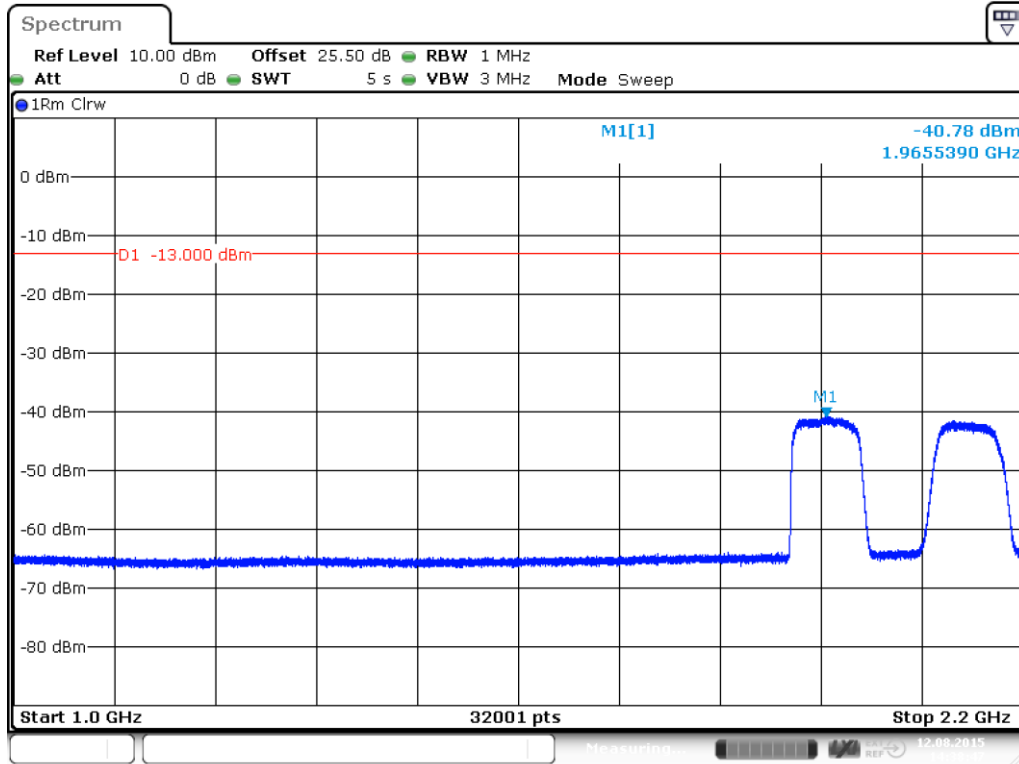

Date: 12.AUG.2015 14:38:47

plot 7.3.1.2-#2 Spurious Emissions at Antenna Terminals: §27.53, §2.1051; Test results; Downlink; LTE; 10 MHz signal; 1 GHz – 2.2 GHz; carrier notched

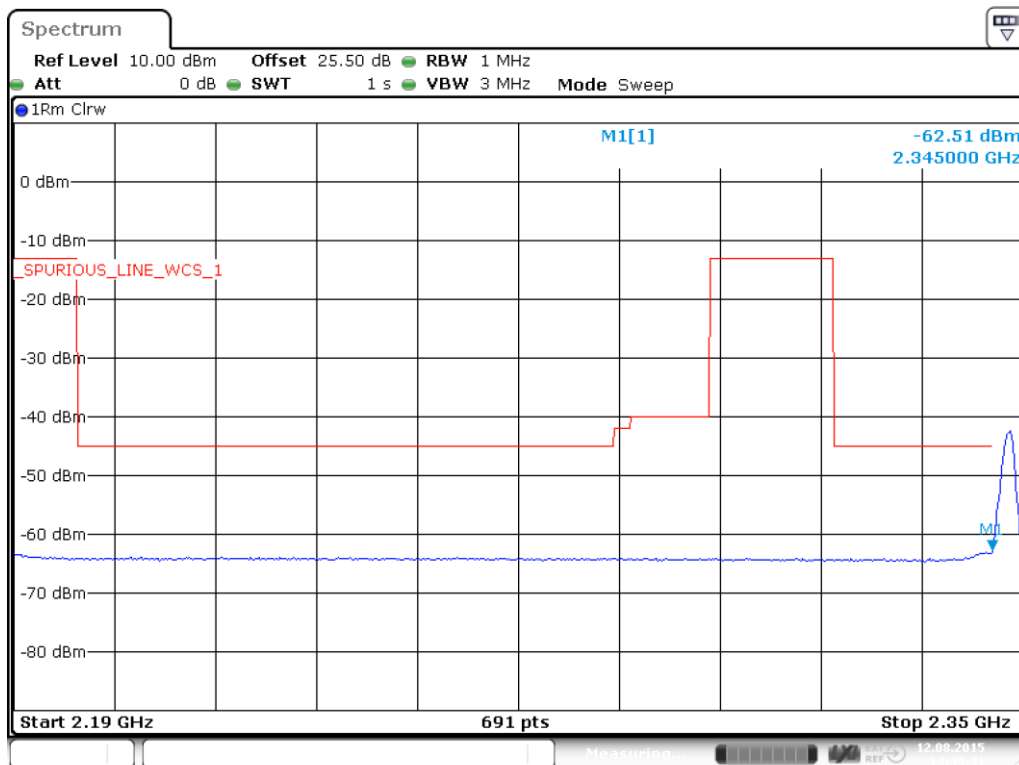

Date: 12.AUG.2015 14:49:42

plot 7.3.1.2-#3 Spurious Emissions at Antenna Terminals: §27.53, §2.1051; Test results; Downlink; LTE; 10 MHz signal; 2.19 GHz – 2.35 GHz; carrier notched

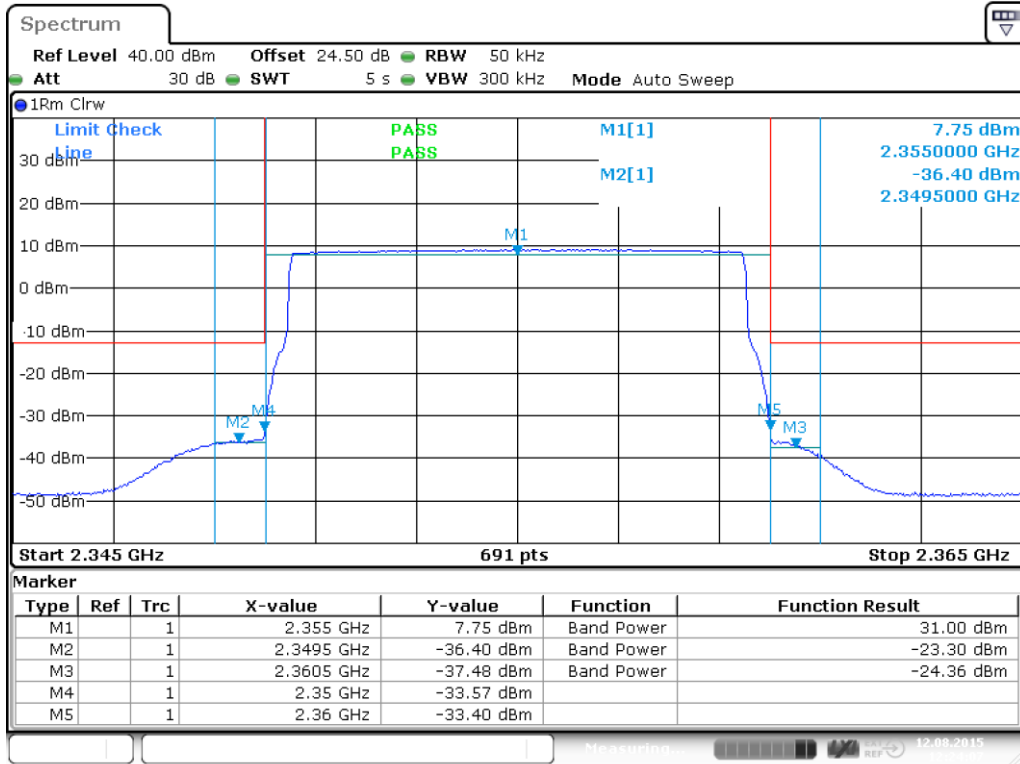

Date: 12.AUG.2015 12:24:07

plot 7.3.1.2-#4 Spurious Emissions at Antenna Terminals: §27.53, §2.1051; Test results; Downlink; LTE; 10 MHz signal; 2.345 GHz – 2.365 GHz;

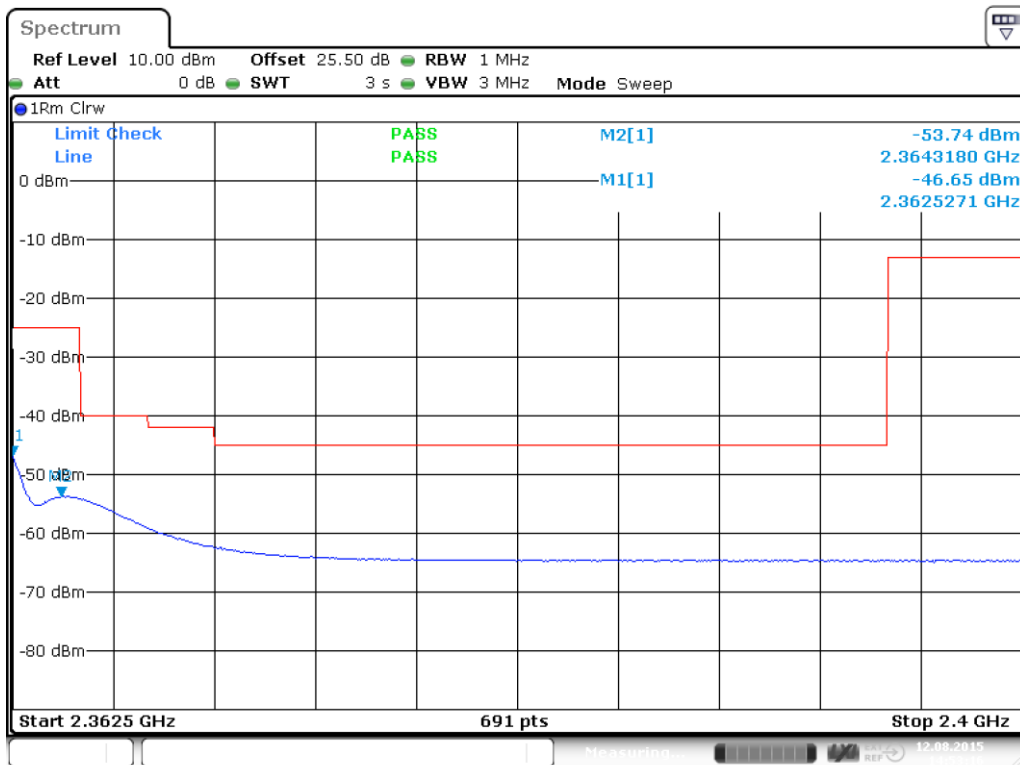

Date: 12.AUG.2015 14:53:16

plot 7.3.1.2-#5 Spurious Emissions at Antenna Terminals: §27.53, §2.1051; Test results; Downlink; LTE; 10 MHz signal; 2.3625 GHz – 2.4 GHz; carrier notched

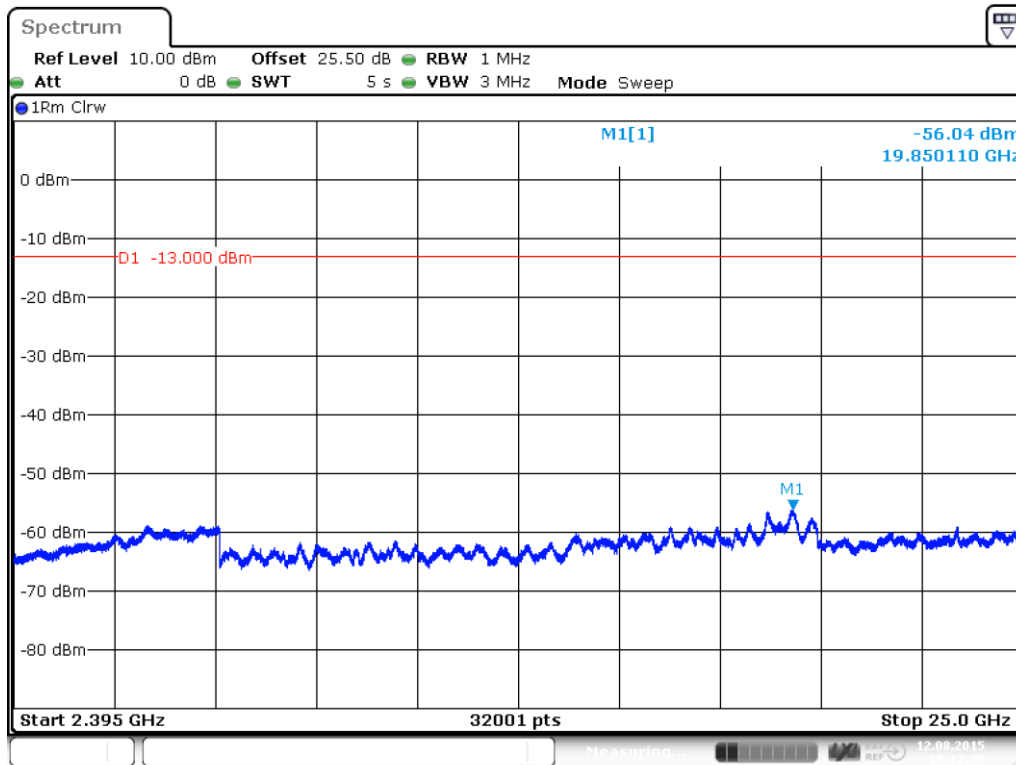

Date: 12.AUG.2015 15:17:25

plot 7.3.1.2-#6 Spurious Emissions at Antenna Terminals: §27.53, §2.1051; Test results; Downlink; LTE; 10 MHz signal; 2.395 GHz – 25 GHz; carrier notched

7.3.2 Uplink

n.a.

Note: The EUT does not transmit over the air in the uplink direction.

7.4 Summary test result

Test result	complies, according the plots above
Tested by:	F. Bengesser
Date:	12.05.2015

8 Intermodulation: §27.53, §2.1051

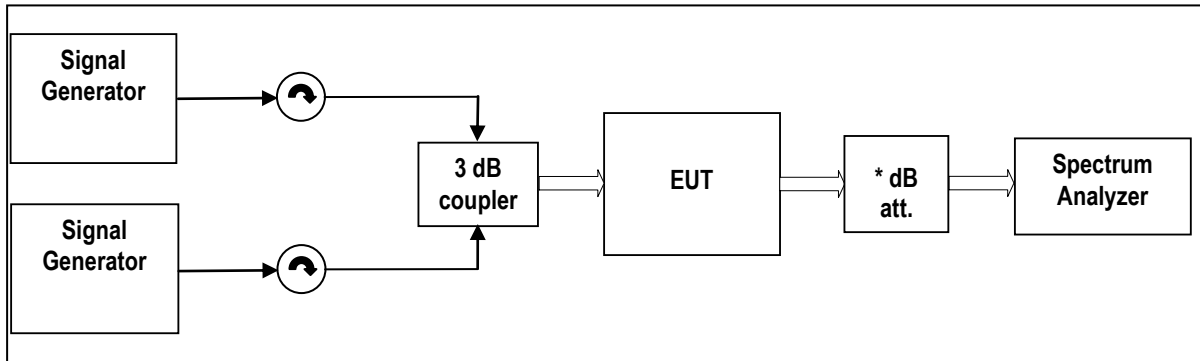

External Attenuator DL x dB = 20 dB
figure 8-#1 Test setup: Intermodulation: §27.53, §2.1051

Measurement uncertainty	± 0,54 dB ± 1,2 dB ± 1,5 dB	9 kHz to 3 GHz 3 GHz to 7 GHz 7 GHz to 26 GHz
Test equipment used	9069, 9046, 9126, 7406	

8.1 Limit

(a) For operations in the 2305-2320 MHz band and the 2345-2360 MHz band, the power of any emission outside a licensee's frequency band(s) of operation shall be attenuated below the transmitter power P (with averaging performed only during periods of transmission) within the licensed band(s) of operation, in watts, by the following amounts:

(1) For base and fixed stations' operations in the 2305-2320 MHz band and the 2345-2360 MHz band:

(i) By a factor of not less than $43 + 10 \log (P)$ dB on all frequencies between 2305 and 2320 MHz and on all frequencies between 2345 and 2360 MHz that are outside the licensed band(s) of operation, and not less than $75 + 10 \log (P)$ dB on all frequencies between 2320 and 2345 MHz;

(ii) By a factor of not less than $43 + 10 \log (P)$ dB on all frequencies between 2300 and 2305 MHz, $70 + 10 \log (P)$ dB on all frequencies between 2287.5 and 2300 MHz, $72 + 10 \log (P)$ dB on all frequencies between 2285 and 2287.5 MHz, and $75 + 10 \log (P)$ dB below 2285 MHz;

(iii) By a factor of not less than $43 + 10 \log (P)$ dB on all frequencies between 2360 and 2362.5 MHz, $55 + 10 \log (P)$ dB on all frequencies between 2362.5 and 2365 MHz, $70 + 10 \log (P)$ dB on all frequencies between 2365 and 2367.5 MHz, $72 + 10 \log (P)$ dB on all frequencies between 2367.5 and 2370 MHz, and $75 + 10 \log (P)$ dB above 2370 MHz.

(2) For fixed customer premises equipment (CPE) stations operating in the 2305-2320 MHz band and the 2345-2360 MHz band transmitting with more than 2 watts per 5 megahertz average EIRP:

(i) By a factor of not less than $43 + 10 \log (P)$ dB on all frequencies between 2305 and 2320 MHz and on all frequencies between 2345 and 2360 MHz that are outside the licensed band(s) of operation, and not less than $75 + 10 \log (P)$ dB on all frequencies between 2320 and 2345 MHz;

(ii) By a factor of not less than $43 + 10 \log (P)$ dB on all frequencies between 2300 and 2305 MHz, $70 + 10 \log (P)$ dB on all frequencies between 2287.5 and 2300 MHz, $72 + 10 \log (P)$ dB on all frequencies between 2285 and 2287.5 MHz, and $75 + 10 \log (P)$ dB below 2285 MHz;



(iii) By a factor of not less than $43 + 10 \log (P)$ dB on all frequencies between 2360 and 2362.5 MHz, $55 + 10 \log (P)$ dB on all frequencies between 2362.5 and 2365 MHz, $70 + 10 \log (P)$ dB on all frequencies between 2365 and 2367.5 MHz, $72 + 10 \log (P)$ dB on all frequencies between 2367.5 and 2370 MHz, and $75 + 10 \log (P)$ dB above 2370 MHz.

If the DUT used in MIMO configuration according to KDB 662911, the summed emission (MIMO Max. Level) is calculated (Max. Level) of the output port plus $10 \log (N_{ANT})$. With $(N_{ANT} = 2)$ the MIMO Max. Level (dBm) equals Max. Level (dBm) plus 3dB.

8.2 Test method

Para. No 2.1051 Measurements required: Spurious emissions at antenna terminals. The radio frequency voltage or powers generated within the equipment and appearing on a spurious frequency shall be checked at the equipment output terminals when properly loaded with a suitable artificial antenna. Curves or equivalent data shall show the magnitude of each harmonic and other spurious emission that can be detected when the equipment is operated under the conditions specified in § 2.1049 as appropriate. The magnitude of spurious emissions which are attenuated more than 20 dB below the permissible value need not be specified.

[39 FR 5919, Feb. 15, 1974. Redesignated and amended at 63 FR 36599, July 7, 1998]

8.3 Test results

8.3.1 Downlink

Detector: RMS.

Modulation	Carrier(s) F / MHz	Limit pass/fail	Limit with MIMO pass/fail	Plot -
2 x LTE 5 MHz	2352.5 2357.5	pass	pass	8.3.1.1 1
LTE 10 MHz	2355	pass	pass	8.3.1.2 1

table 8.3-#1 Intermodulation: §27.53, §2.1051 Test results

8.3.1.1 LTE; 2 x 5 MHz signal

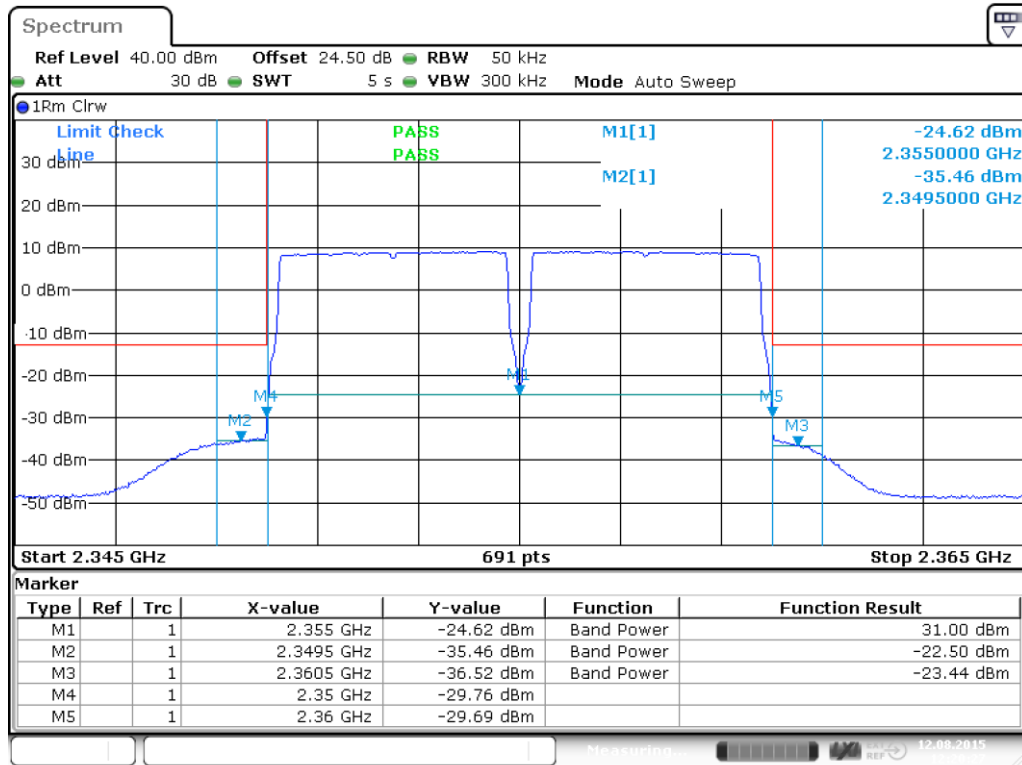

Date: 12.AUG.2015 12:20:28

plot 8.3.1.1-#1 Intermodulation: §27.53, §2.1051; Test results; Downlink; LTE; 2 x 5 MHz signal; 2.345 GHz – 2.365 GHz



8.3.1.2 LTE; 10 MHz signal

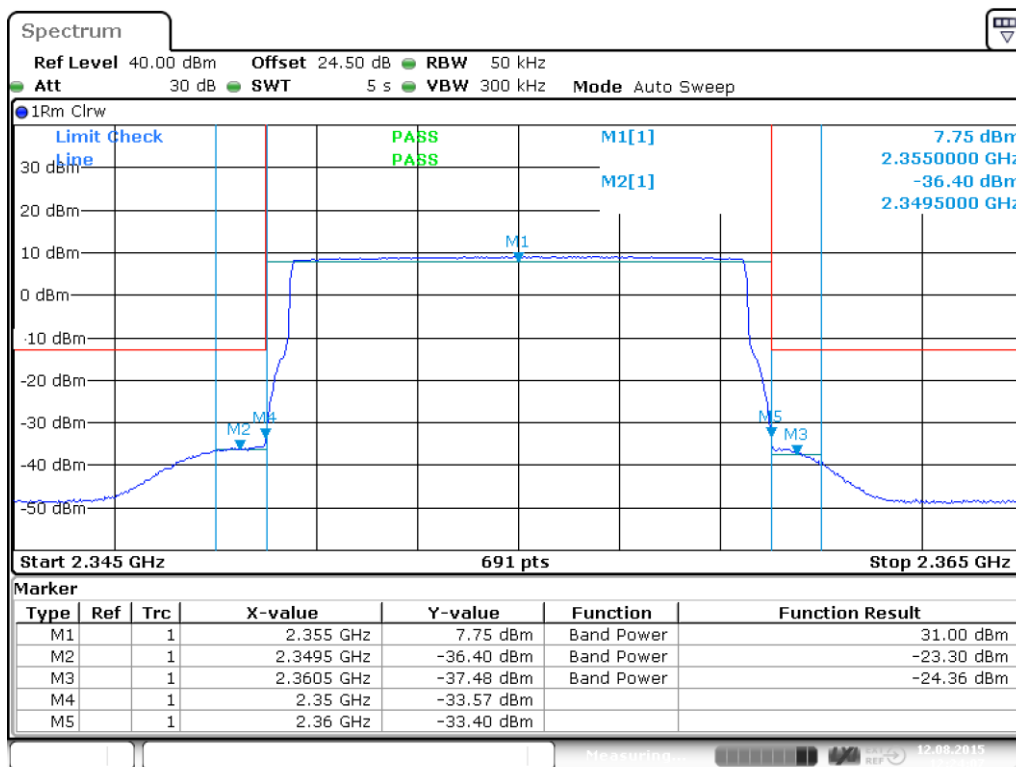

Date: 12.AUG.2015 12:24:07

plot 8.3.1.2-#1 Intermodulation: §27.53, §2.1051; Test results; Downlink; LTE; 10 MHz signal; 2.345 GHz – 2.365 GHz;

8.3.2 Uplink

n.a.

Note: The EUT does not transmit over the air in the uplink direction.

8.4 Summary test result

Test result	complies, according the plots above
Tested by:	F. Bengesser
Date:	12.08.2015

9 Out of Band Rejection

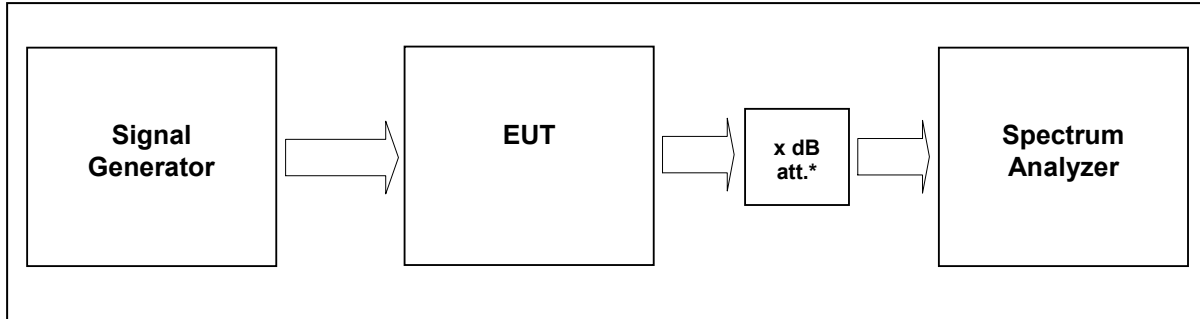

External Attenuator DL x dB = 20 dB
figure 9-#1 Test setup: Out of Band Rejection

Measurement uncertainty	± 0,38 dB
Test equipment used	9069, 9046, 9126, 7406

9.1 Limit

KDB 935210 D02 v02

Test for rejection of out of band signals. Filter frequency response plots are acceptable.

9.2 Test method

935210 D03 v02

7.1 Authorized frequency band verification test

9.3 Test results

Detector Peak max hold



9.3.1 Downlink

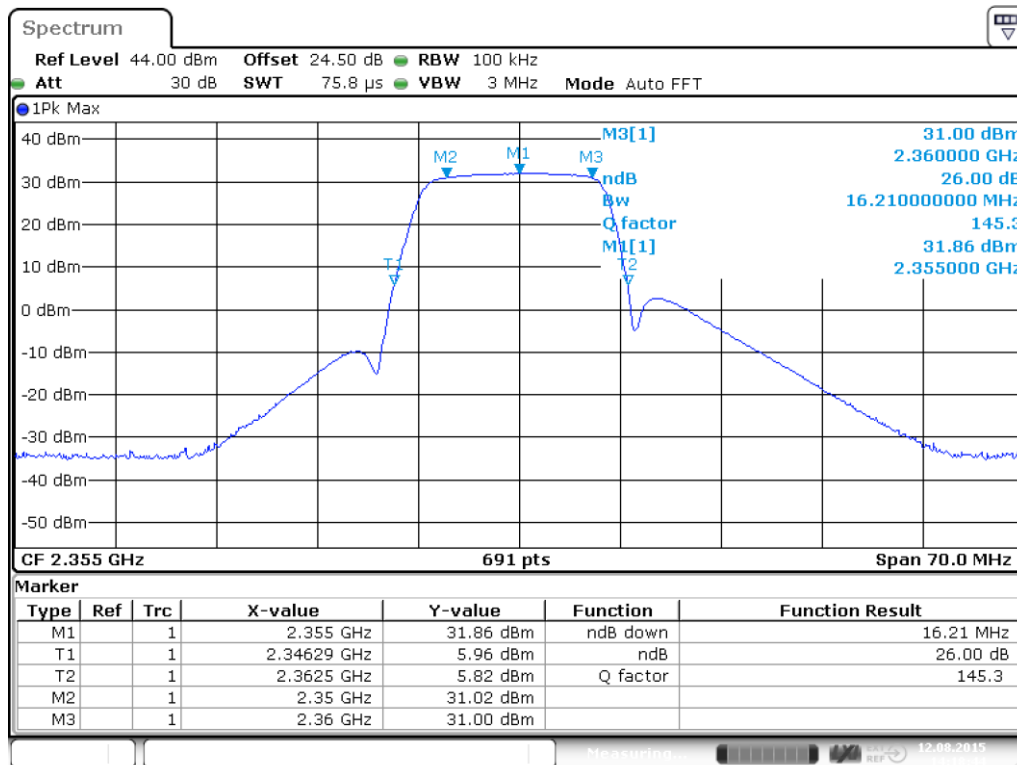

Date: 12.AUG.2015 14:18:45

plot 9.3.1-#1 Out of Band Rejection; Test results; Downlink;

9.3.2 Uplink

n.a.

Note: The EUT does not transmit over the air in the uplink direction.

9.4 Summary test result

Test result	complies, according the plots above
Tested by:	F. Bengesser
Date:	12.08.2015

10 Radiated Spurious Emissions at the ECL (BV): §27.53, §2.1051



picture 8.1: label



picture 8.2: auxiliary equipment

The radiated emission was tested with the worst case configuration (MIMO), where the highest interferers to be expected.

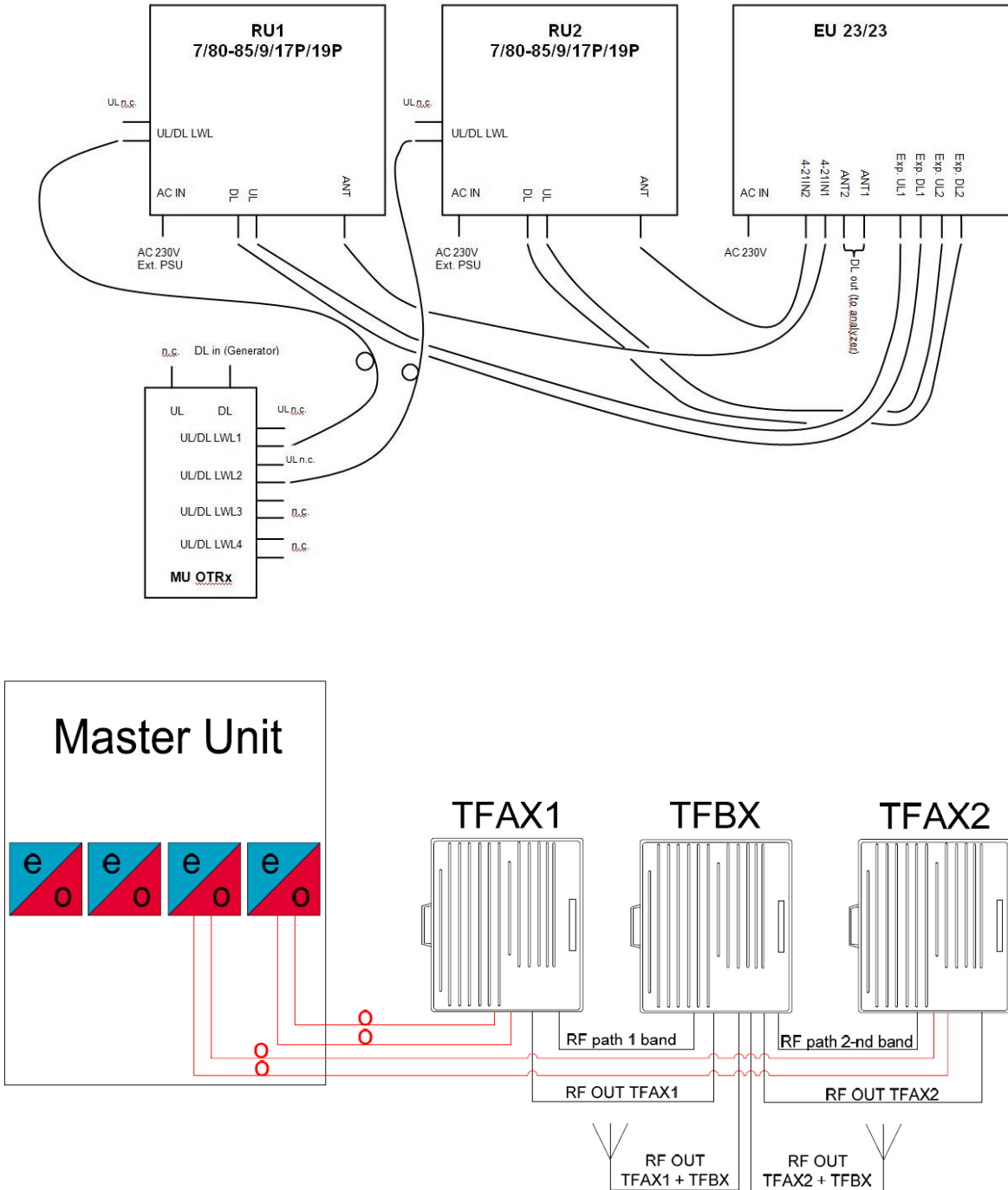

picture 8.3: test configuration

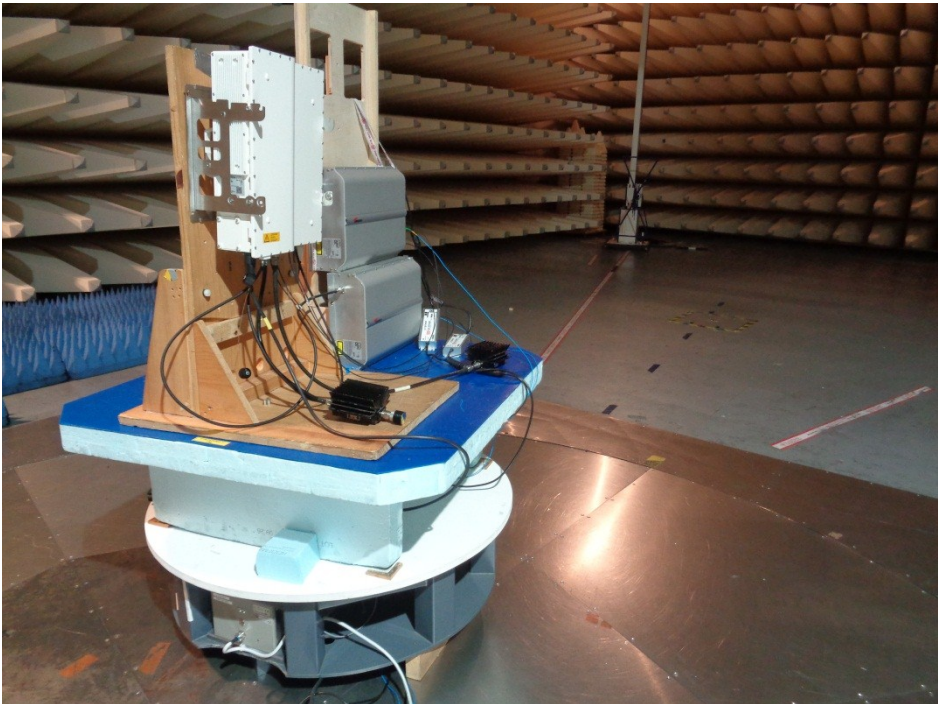
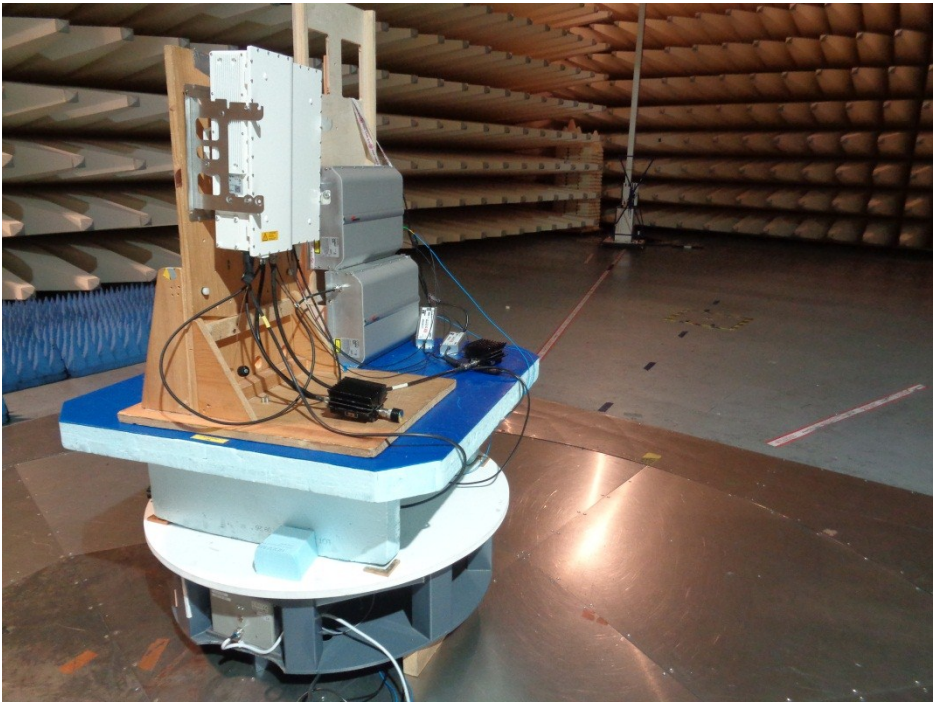

picture 8.4: Test setup: Field Strength Emission



This clause specifies requirements for the measurement of radiated emission.

Frequency range	Distance: EUT <-> antenna / location	Limit	Test method
30 MHz – 1 GHz	10 metres / SAC	FCC 47 CFR Part 27.53	TIA/EIA-603-C:2004
1 – 26 GHz	3 metres / SAC		

Test equipment used:

Designation	Type	Manufacturer	Invent.-no.	Cal.-date	due Cal.- date	used
EMI test receiver	ESU40	Rohde & Schwarz	E2025	18.05.2015	18.05.2016	X
Antenna	CBL 6111	Chase	K1149	09.03.2015	09.03.2016	X
RF Cable	RG214	Frankonia	K1121	16.04.2015	16.04.2017	X
Antenna	HL 025	R&S	K1114	09.03.2015	09.03.2016	X
Preamplifier	AFS4-00102000	Miteq	K838	17.06.2015	17.06.2016	X
RF Cable	Sucoflex 100	Suhner	K1760	04.08.2015	04.08.2016	X

The REMI version 2.135 has been used to maximize radiated emission from the EUT with regards to ANSI C63.4:2009.

Test set-up:

Test location: SAC / FAC
 Both, the Fully Anechoic Chamber (FAC) and the Semi Anechoic Chamber (SAC) fulfil the requirements of ANSI C63.4 and CISPR 16-1-4 with regards to NSA and SVSWR.

Test Voltage: 110 V / 60 Hz
 Type of EUT: Wall mounted

Measurement uncertainty:

Measurement uncertainty expanded (95% or K=2)	± 4,7 dB for ANSI C63.4 measurement ± 0,5 dB for TIA-603 measurement
--	---

10.1 Method of Measurement

Measurement procedure. TIA-603-C

The antenna substitution method is used to determine the equivalent radiated power at spurious frequencies. The spurious emissions are measured at a distance of 3 meters. The EUT is then replaced with a reference substitution antenna with a known gain referenced to a dipole. This antenna is fed with a signal at the spurious frequency. The level of the signal is adjusted to repeat the previously measured level. The resulting eirp is the signal level fed to the reference antenna corrected for gain referenced to an isotropic dipole (see Figure 7.2).

From KDB (AMPLIFIER, BOOSTER, AND REPEATER REMINDER SHEET):

Radiated spurs (enclosure) – Use of CW signal (low, mid, and high freq.) is acceptable rather than all modulations. The Bottom/Middle/Top frequencies for Part 27 F/H are as follows:

- 728/737/746 MHz (§27 Subpart H)
- 746/755/763 MHz (§27 Subpart F)

The maximum RFI field strength was determined during the measurement by rotating the turntable (± 180 degrees) as like defined in ANSI C63.4. A measurement receiver has been used with a RBW 120 kHz up to 1 GHz and 1 MHz above 1 GHz. Steps width during the measurement was half the RBW.

Both, the Fully Anechoic Chamber (FAC) and the Semi Anechoic Chamber (SAC) fulfil the requirements of ANSI C63.4 and CISPR 16-1-4 with regards to NSA and SVSWR.

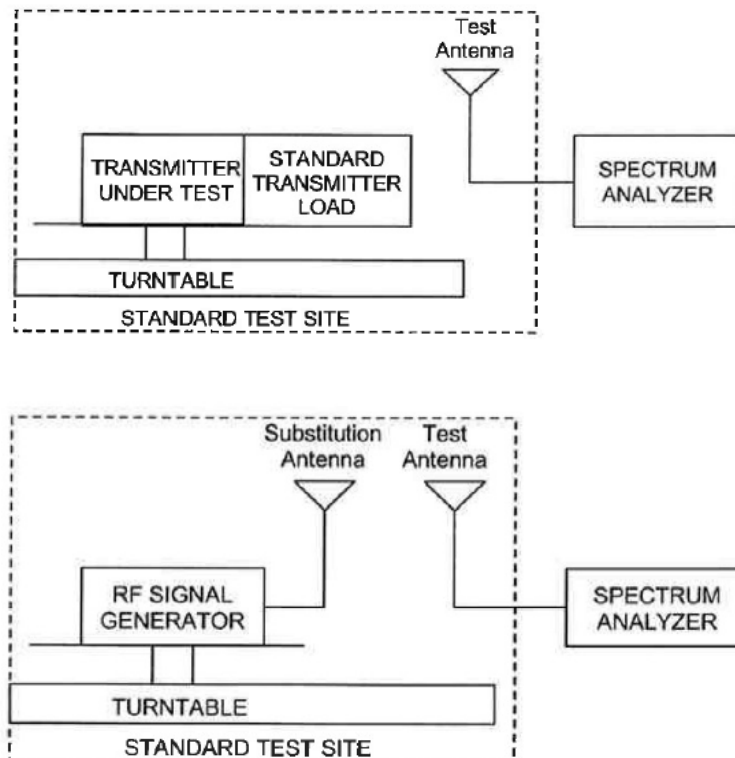

Figure #8.3 Substitution methods TIA/EIA-603-C



10.2 Limit

(a) For operations in the 2305-2320 MHz band and the 2345-2360 MHz band, the power of any emission outside a licensee's frequency band(s) of operation shall be attenuated below the transmitter power P (with averaging performed only during periods of transmission) within the licensed band(s) of operation, in watts, by the following amounts:

(1) For base and fixed stations' operations in the 2305-2320 MHz band and the 2345-2360 MHz band:

(i) By a factor of not less than $43 + 10 \log (P)$ dB on all frequencies between 2305 and 2320 MHz and on all frequencies between 2345 and 2360 MHz that are outside the licensed band(s) of operation, and not less than $75 + 10 \log (P)$ dB on all frequencies between 2320 and 2345 MHz;

(ii) By a factor of not less than $43 + 10 \log (P)$ dB on all frequencies between 2300 and 2305 MHz, $70 + 10 \log (P)$ dB on all frequencies between 2287.5 and 2300 MHz, $72 + 10 \log (P)$ dB on all frequencies between 2285 and 2287.5 MHz, and $75 + 10 \log (P)$ dB below 2285 MHz;

(iii) By a factor of not less than $43 + 10 \log (P)$ dB on all frequencies between 2360 and 2362.5 MHz, $55 + 10 \log (P)$ dB on all frequencies between 2362.5 and 2365 MHz, $70 + 10 \log (P)$ dB on all frequencies between 2365 and 2367.5 MHz, $72 + 10 \log (P)$ dB on all frequencies between 2367.5 and 2370 MHz, and $75 + 10 \log (P)$ dB above 2370 MHz.

(2) For fixed customer premises equipment (CPE) stations operating in the 2305-2320 MHz band and the 2345-2360 MHz band transmitting with more than 2 watts per 5 megahertz average EIRP:

(i) By a factor of not less than $43 + 10 \log (P)$ dB on all frequencies between 2305 and 2320 MHz and on all frequencies between 2345 and 2360 MHz that are outside the licensed band(s) of operation, and not less than $75 + 10 \log (P)$ dB on all frequencies between 2320 and 2345 MHz;

(ii) By a factor of not less than $43 + 10 \log (P)$ dB on all frequencies between 2300 and 2305 MHz, $70 + 10 \log (P)$ dB on all frequencies between 2287.5 and 2300 MHz, $72 + 10 \log (P)$ dB on all frequencies between 2285 and 2287.5 MHz, and $75 + 10 \log (P)$ dB below 2285 MHz;

(iii) By a factor of not less than $43 + 10 \log (P)$ dB on all frequencies between 2360 and 2362.5 MHz, $55 + 10 \log (P)$ dB on all frequencies between 2362.5 and 2365 MHz, $70 + 10 \log (P)$ dB on all frequencies between 2365 and 2367.5 MHz, $72 + 10 \log (P)$ dB on all frequencies between 2367.5 and 2370 MHz, and $75 + 10 \log (P)$ dB above 2370 MHz.



10.3 Receiver Settings

	up to 1 GHz	above 1 GHz
Measurement bandwidth	120 kHz	1 MHz
Step width	60 kHz	500 kHz
Dwell time	20ms	
Detector	Peak	Average

10.4 Climatic values in the lab

Temperature	21C
Relative Humidity	50%
Air-pressure	1014 hPa



10.5 Test results

10.5.1 30 MHz to 1 GHz Downlink (Bottom – Middle – Top)

Bottom: 2350 MHz; Middle: 2355 MHz; Top: 2360 MHz

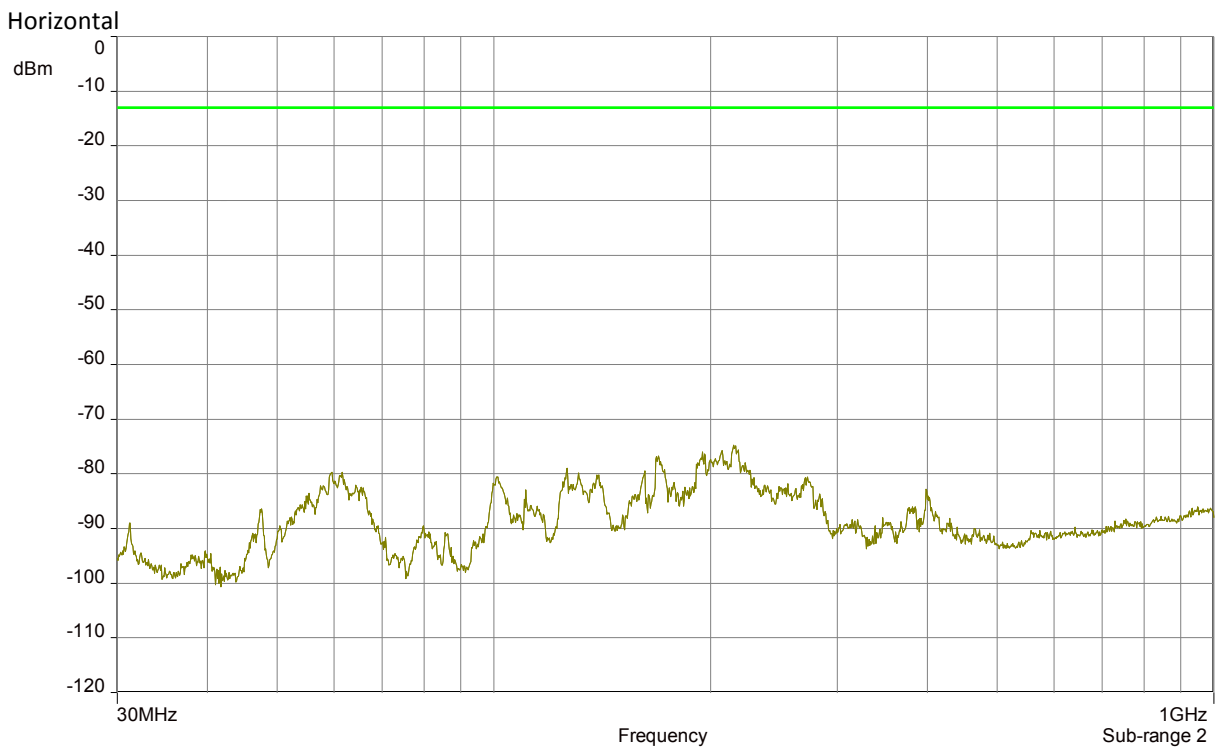
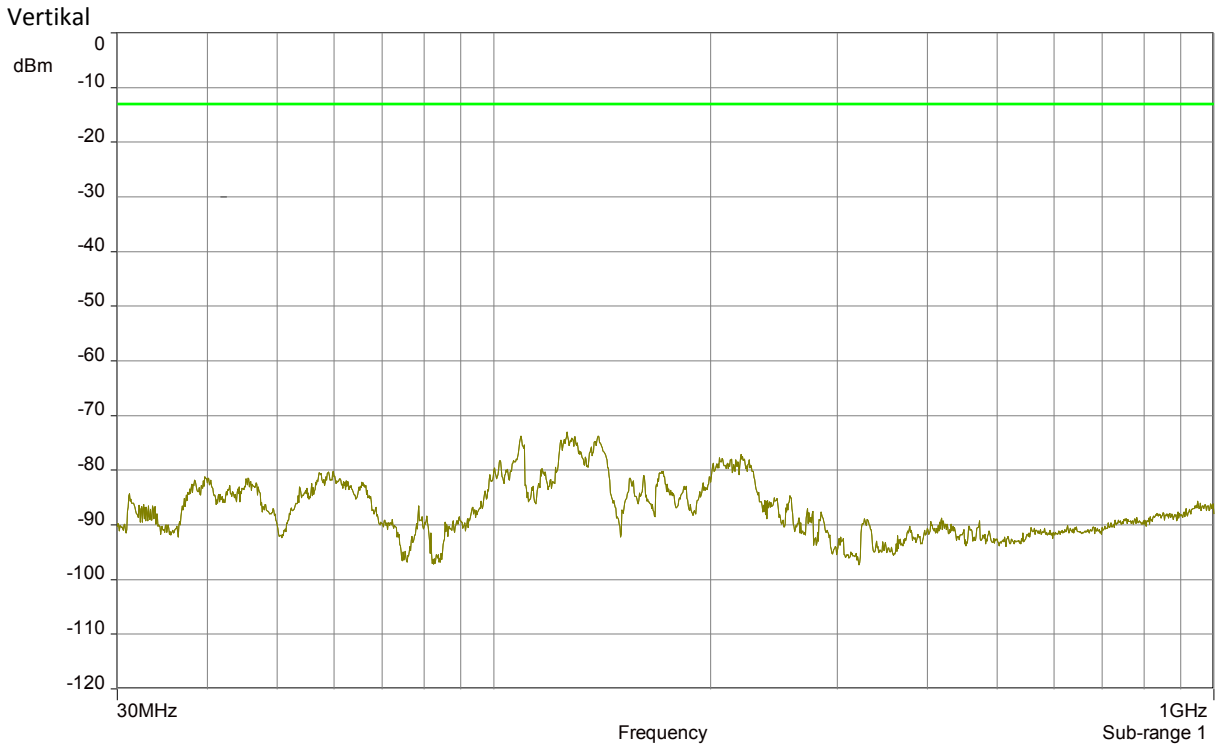

The RF output power is terminated.



10.5.3 30 MHz to 1 GHz Downlink (Middle of all paths)

F1: 742.5 MHz; F2: 876.25 MHz; F3: 1962.5 MHz; F3: 2132.5 MHz; F3: 2355 MHz

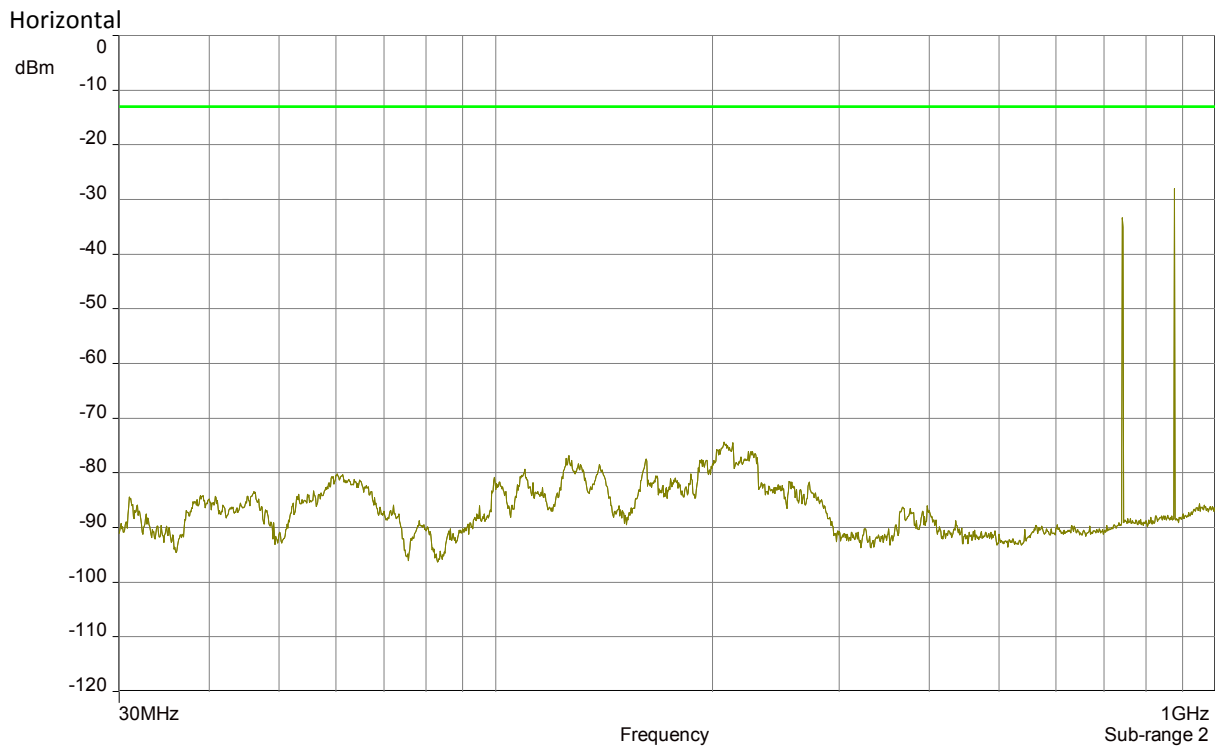
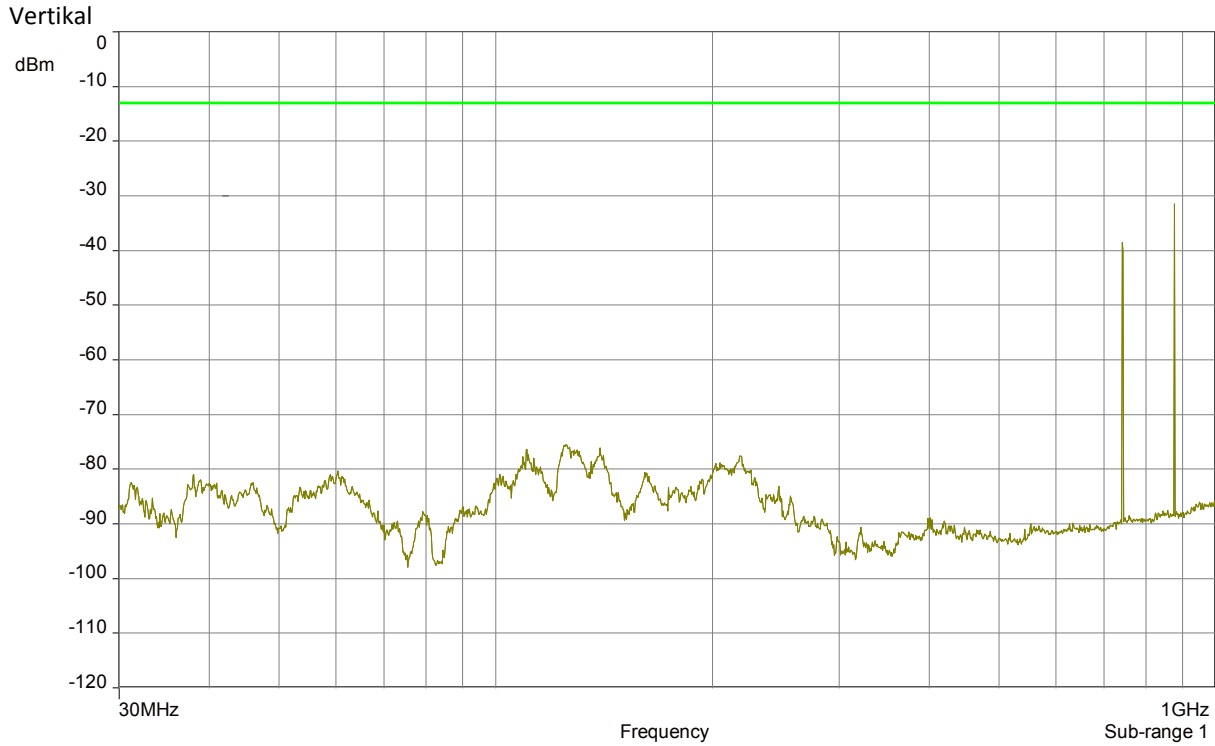

The RF output power is terminated.



10.5.4 1 GHz to 20 GHz Downlink (Bottom – Middle – Top)

Bottom: 2350 MHz; Middle: 2355 MHz; Top: 2360 MHz

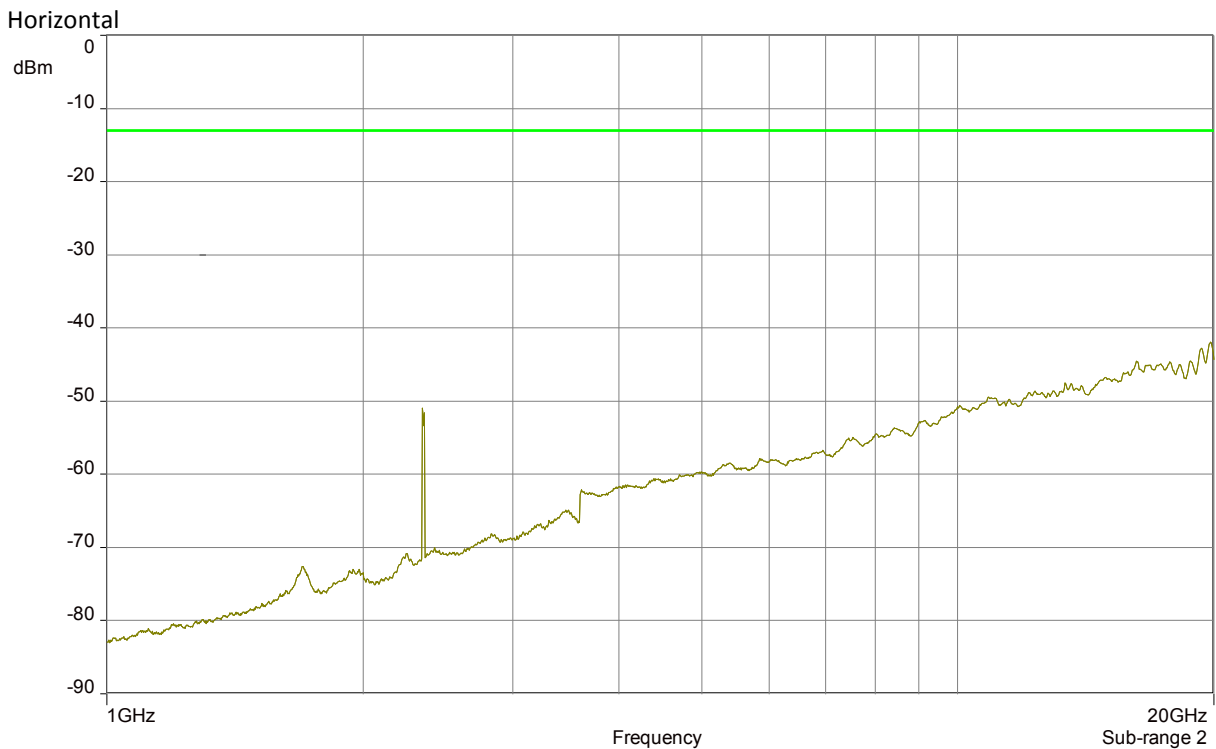
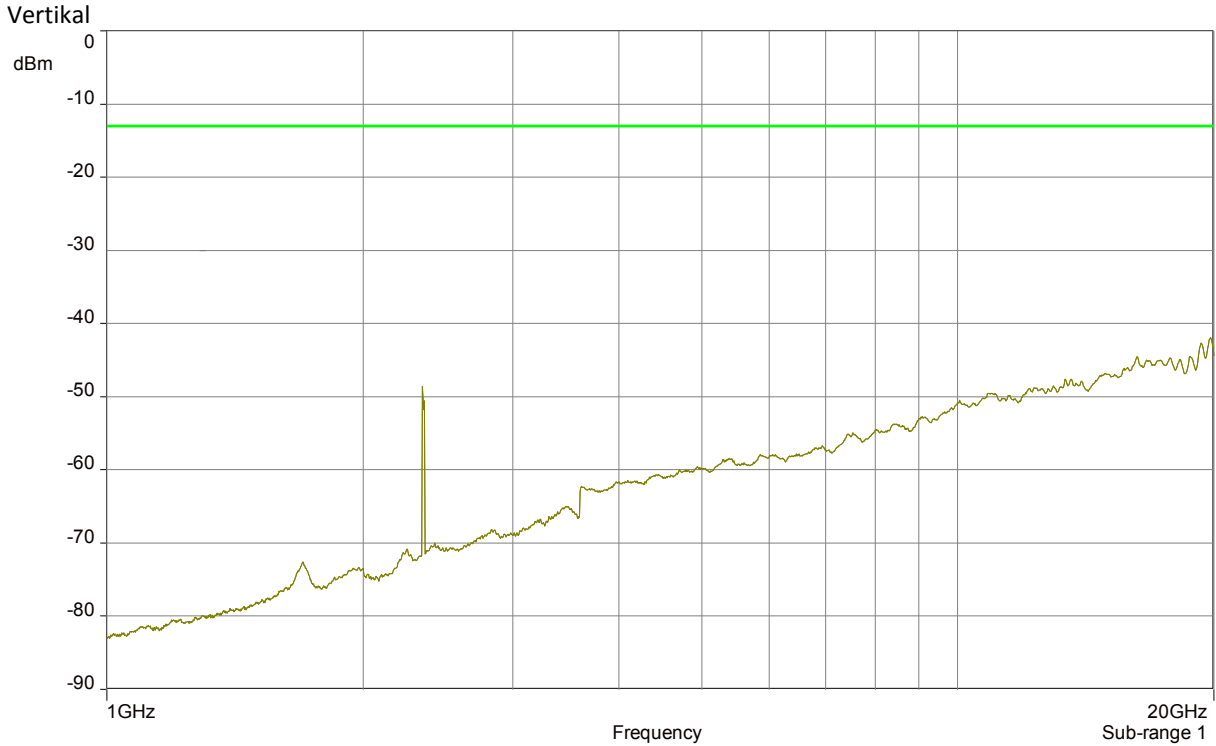

The RF output power is terminated.



10.5.6 1 GHz to 20 GHz Downlink (Middle of all paths)

F1: 742.5 MHz; F2: 876.25 MHz; F3: 1962.5 MHz; F3: 2132.5 MHz; F3: 2355 MHz

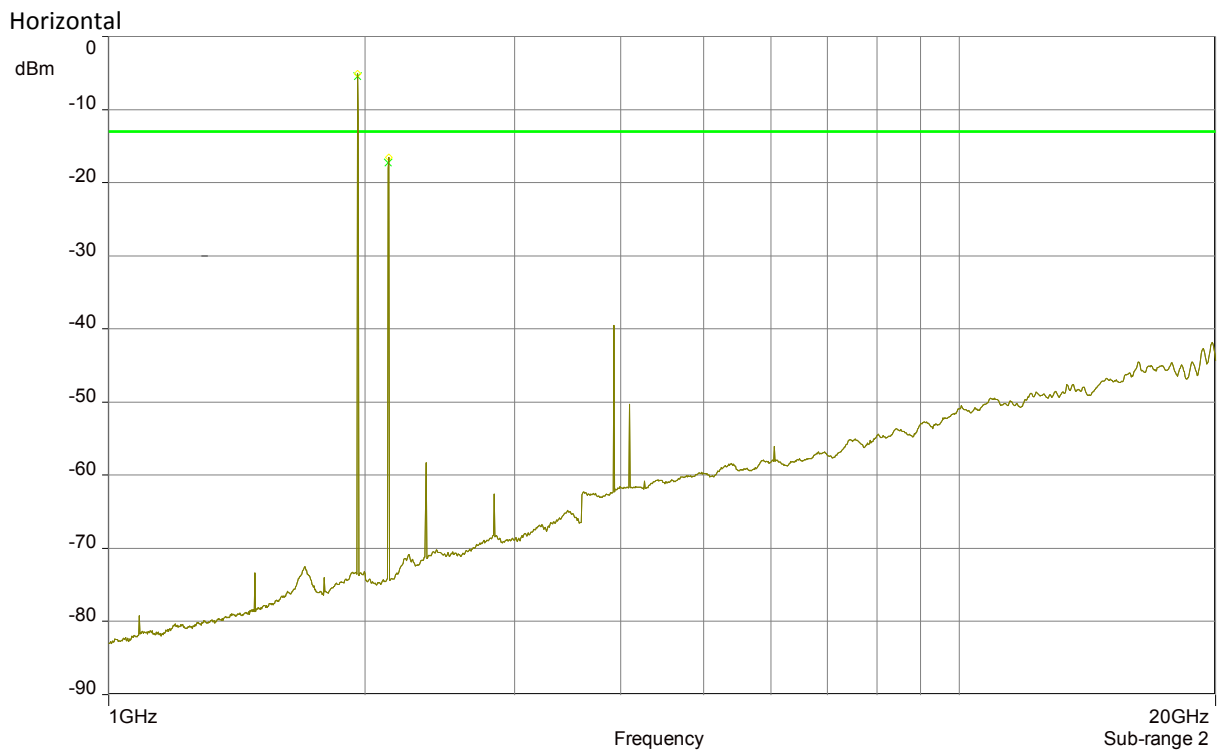
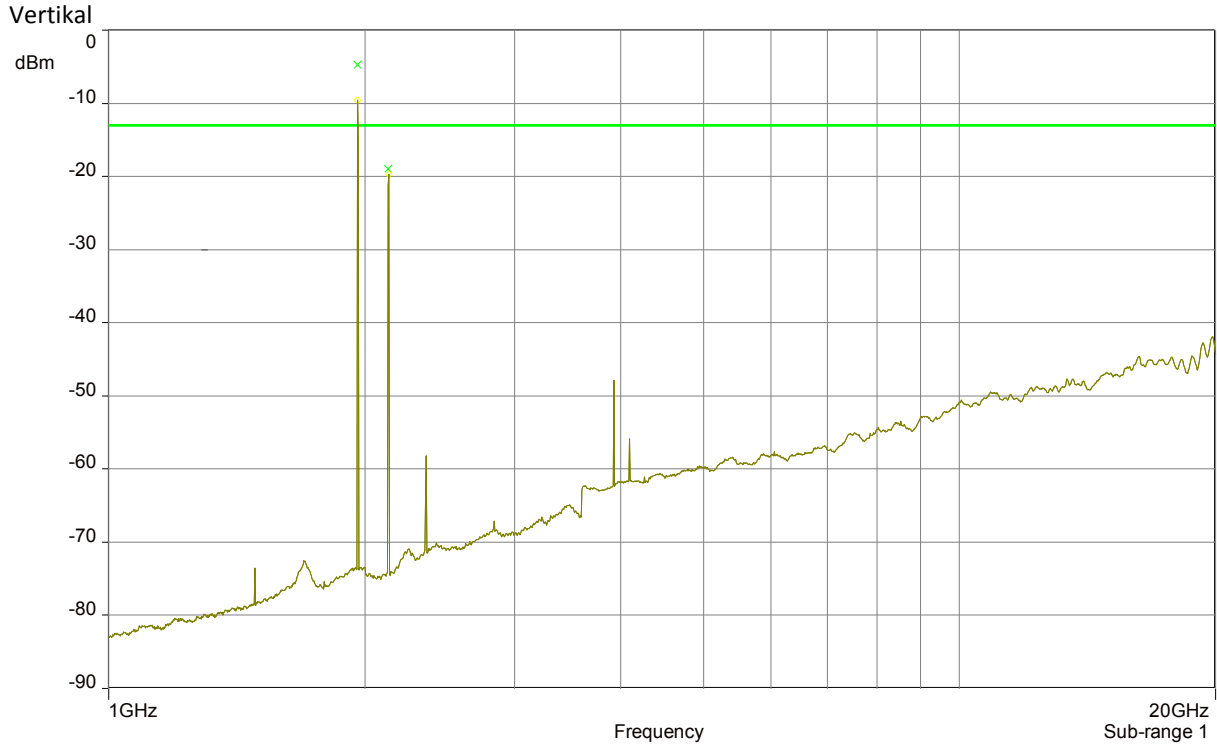



10.5.7 18 GHz to 26 GHz Downlink (Bottom – Middle – Top)

Bottom: 2350 MHz; Middle: 2355 MHz; Top: 2360 MHz

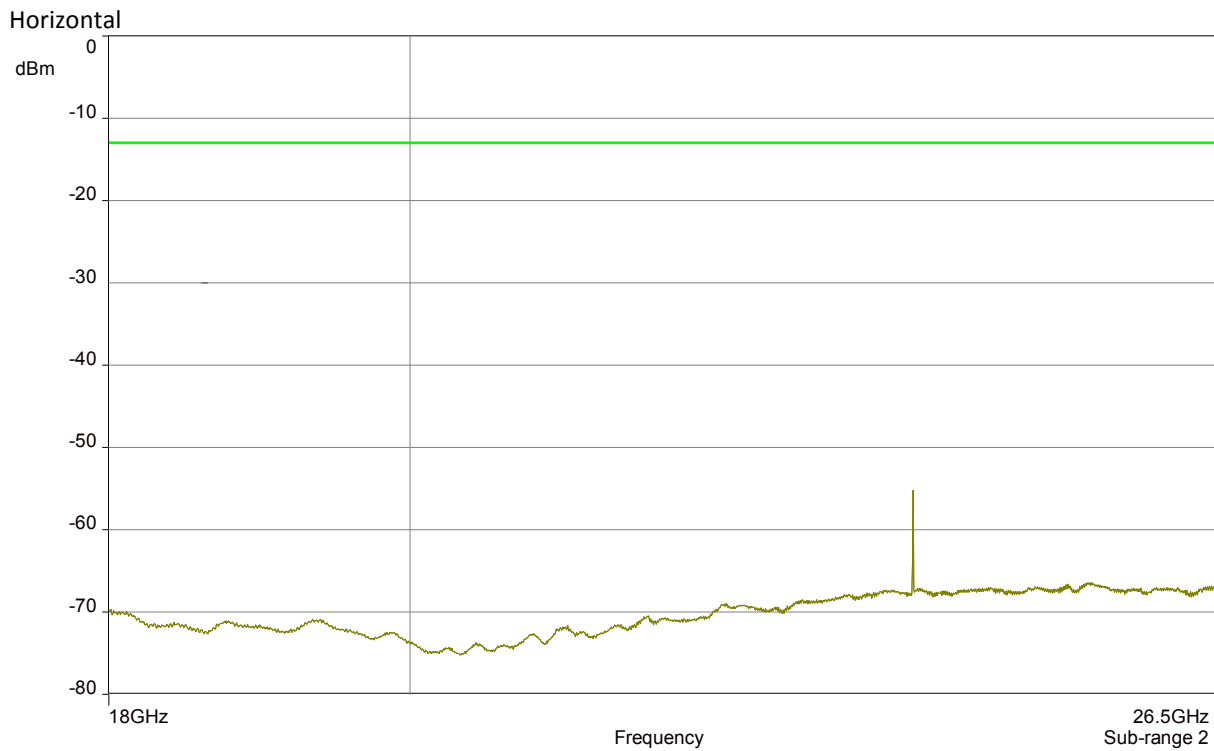
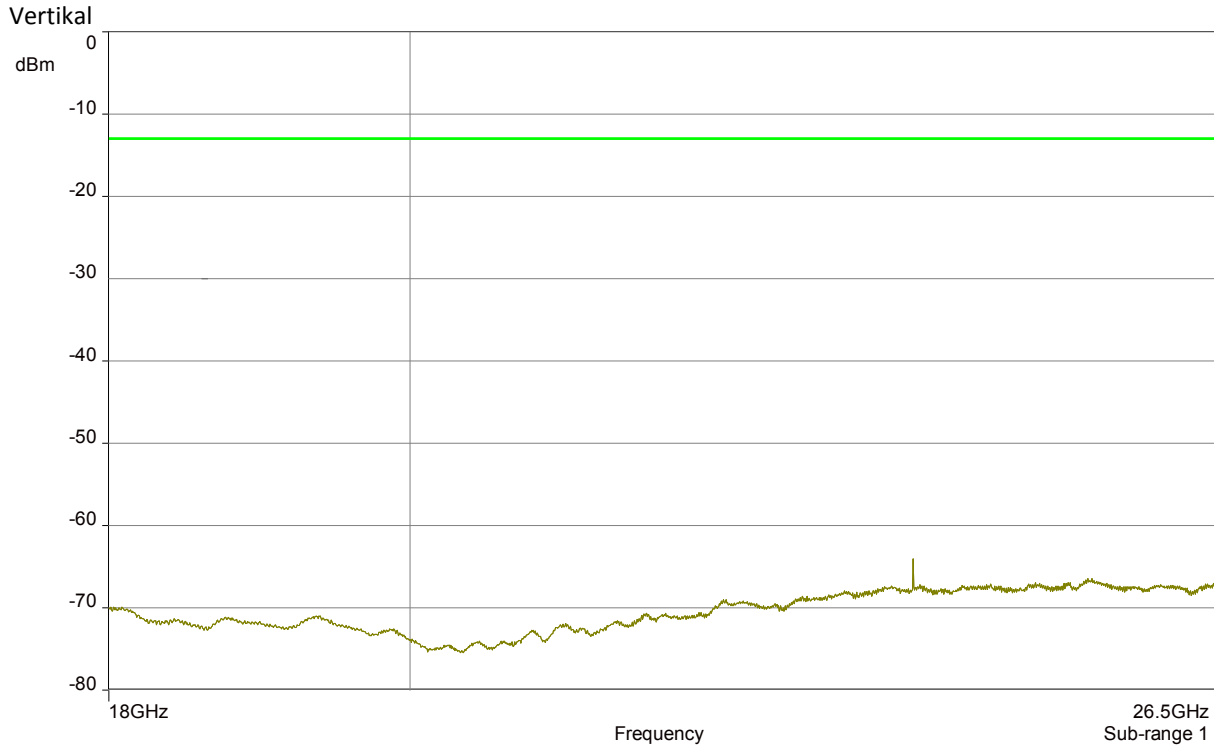

The RF output power is terminated.



10.5.9 18 GHz to 26 GHz Downlink (Middle of all paths)

F1: 742.5 MHz; F2: 876.25 MHz; F3: 1962.5 MHz; F3: 2132.5 MHz; F3: 2355 MHz

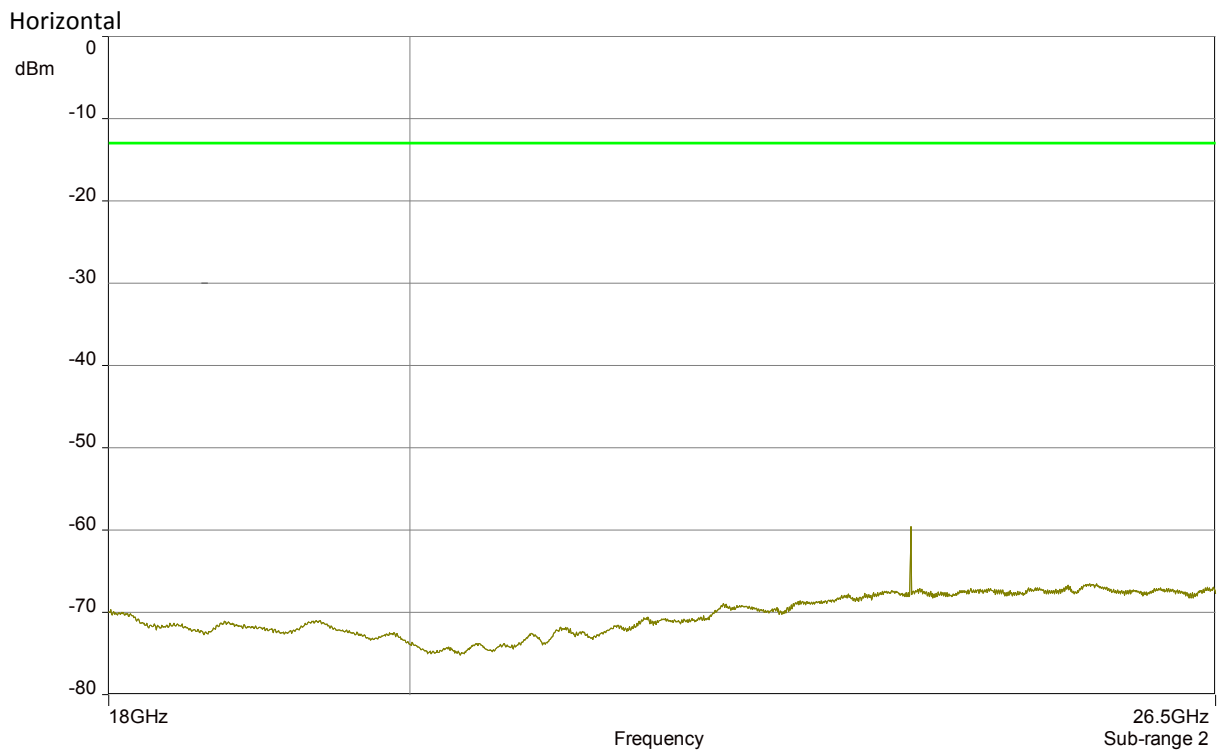
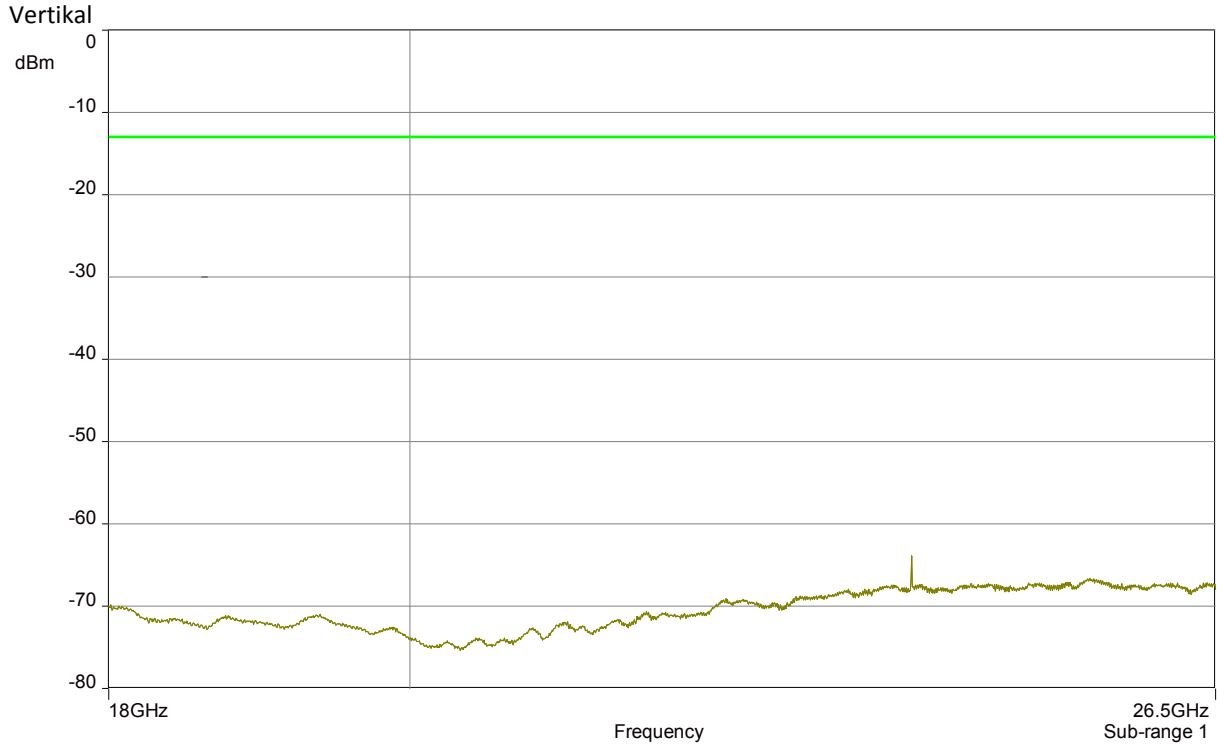

Za / 08.09.2015

The radiated spurious emission measurements have been passed!



11 History

Revision	Modification	Date	Name
01.00	Initial report	14.09.2015	Tom Zahlmann

******* End of test report *******