

Test Site:
FCC Test Site No.:
IC OATS No.:

96997
IC3475A-1



BUREAU
VERITAS

ECL-EMC Test Report No.: 13-050

Equipment under test: ION-U L 7/8/85/17P/19P Vac 1900MHz Path
FCC ID: XS5-U7885L1719P
IC ID: 2237E-U7885L1719P
Type of test: **FCC 47 CFR Part 24 Subpart E: 2013**
Broadband PCS
IC RSS-131:2003
Zone Enhancers for the Land Mobile Service

Measurement Procedures: 47 CFR Parts 2: 2013(*Frequency Allocations and Radio Treaty Matters; General Rules and Regulations*), 24: 2013 (Personal Communications Services), ANSI/TIA-603-C (2004), *Land Mobile FM or PM Communications Equipment Measurement and Performance Standards*
IC-GEN General Requirements and Information for the Certification of Radiocommunication Equipment

Test result: **Passed**

Date of issue:	25.06.13	Signature:	
Issue-No.:	02	Author:	
Date of delivery:	08.02.13	Checked:	
Test dates:	14.01. – 08.02.13		
Pages:	59		

Test Report No.: 13-050

FCC ID: XS5-U7885L1719P

IC ID: 2237E-U7885L1719P



BUREAU
VERITAS

Manufacturer: ANDREW Wireless Systems GmbH
Industriering 10

D-86675 Buchdorf

Tel.: +49 (0)9099 69 0

Fax: +49 (0)9099 69 140

Test house: Bureau Veritas Consumer Products Services
Germany GmbH
European Compliance Laboratory (ECL)
Thurn-und-Taxis-Straße 18

D-90411 Nürnberg

Tel.: +49 40 74041 0

Fax: +49 40 74041-2755

General:

The purpose of this report is to show compliance to the FCC regulations for unlicensed devices operating under section 15.249 of the Code of Federal Regulations title 47.

This report informs about the results of the EMC tests, it only refers to the equipment under test. No part of this report may be reproduced in any form, without written permission.



Table of contents

TEST RESULTS SUMMARY	6
1 EQUIPMENT UNDER TEST (E.U.T.)	7
1.1 DESCRIPTION	7
1.1.1 DOWNLINK	7
1.1.2 UPLINK	7
1.1.3 DESCRIPTION OF EUT	7
1.1.4 BLOCK DIAGRAM OF MEASUREMENT REFERENCE POINTS	8
1.1.5 DOWNLINK SYSTEM GAIN AND OUTPUT POWER	8
2 TEST SITE (ANDREW BUCHDORF)	9
2.1 TEST ENVIRONMENT	9
2.2 TEST EQUIPMENT	9
2.3 INPUT AND OUTPUT LOSSES	10
2.4 MEASUREMENT UNCERTAINTY	10
3 TEST SITE (BUREAU VERITAS CONSUMER PRODUCT SERVICES)	10
4 RF POWER OUT: §24.232, §2.1046	11
4.1 LIMIT	11
4.2 TEST METHOD	11
4.3 TEST RESULTS	12
4.3.1 DOWNLINK	13
4.3.1.1 Analog	14
4.3.1.2 GSM	14
4.3.1.3 EDGE	15
4.3.1.4 CDMA	15
4.3.1.5 W-CDMA	16
4.3.1.6 LTE	16
4.3.2 UPLINK	17
4.4 SUMMARY TEST RESULT	17
5 OCCUPIED BANDWIDTH: §2.1049	18
5.1 LIMIT	18
5.2 TEST METHOD	18
5.3 TEST RESULTS	19
5.3.1 DOWNLINK	19
5.3.1.1 Analog	20
5.3.1.2 GSM	21
5.3.1.3 EDGE	22
5.3.1.4 CDMA	23
5.3.1.5 W-CDMA	24
5.3.1.6 LTE	25
5.3.2 UPLINK	26
5.4 SUMMARY TEST RESULT	26
6 SPURIOUS EMISSIONS AT ANTENNA TERMINALS: §24.238, §2.1051	27
6.1 LIMIT	27



6.2	TEST METHOD	27
6.3	TEST RESULTS	28
6.3.1	DOWNLINK	28
6.3.1.1	Analog < 1MHz to band edge	30
6.3.1.2	GSM < 1MHz to band edge	31
6.3.1.3	EDGE < 1MHz to band edge	32
6.3.1.4	CDMA < 1MHz to band edge	33
6.3.1.5	W-CDMA < 1MHz to band edge	34
6.3.1.6	LTE < 1MHz to band edge	35
6.3.1.7	Analog > 1MHz to band edge	36
6.3.1.8	GSM > 1MHz to band edge	37
6.3.1.9	EDGE > 1MHz to band edge	38
6.3.1.10	CDMA > 1MHz to band edge	39
6.3.1.11	W-CDMA > 1MHz to band edge	40
6.3.1.12	LTE > 1MHz to band edge	41
6.3.2	UPLINK	42
6.4	SUMMARY TEST RESULT	42
7	TRANSMITTER OUTPUT POWER: IC RSS-133, RSS-GEN	43
7.1	LIMIT	43
7.2	TEST METHOD	43
7.3	TEST RESULTS	44
7.3.1	DOWNLINK	44
7.3.1.1	Analog	45
7.3.1.2	GSM	45
7.3.1.3	EDGE	46
7.3.1.4	CDMA	46
7.3.1.5	W-CDMA	47
7.3.1.6	LTE	47
7.3.2	UPLINK	48
7.4	SUMMARY TEST RESULT	48
8	TRANSMITTER UNWANTED EMISSIONS: IC RSS-133	49
8.1	LIMIT	49
8.2	TEST METHOD	49
8.3	TEST RESULTS	49
9	RECEIVER SPURIOUS EMISSIONS: IC RSS-133	50
9.1	LIMIT	50
10	RADIATED SPURIOUS EMISSIONS: §24.238, §2.1053, RSS-133	51
10.1	LIMIT §24.238	53
10.2	TEST METHOD ANSI/TIA/EA-603-C	53
10.3	CLIMATIC VALUES IN THE LAB	54
10.4	RECEIVER SETTINGS	54
10.5	TEST RESULTS	55
10.5.1	30 MHz TO 1 GHz DOWNLINK (BOTTOM – MIDDLE – TOP)	55
10.5.2	30 MHz TO 1 GHz DOWNLINK (MIDDLE OF ALL PATHS)	56
10.5.3	1 – 22 GHz DOWNLINK (BOTTOM – MIDDLE – TOP)	57
10.5.4	1 – 22 GHz DOWNLINK (MIDDLE OF ALL PATHS)	58

Test Report No.: 13-050

FCC ID: XS5-U7885L1719P

IC ID: 2237E-U7885L1719P



11 HISTORY59

Test Report No.: 13-050

FCC ID: XS5-U7885L1719P

IC ID: 2237E-U7885L1719P



**BUREAU
VERITAS**

Test Results Summary

Name of Test	FCC Para. No.	FCC Method	FCC Spec.	Result
RF Power Output	24.232(a)	2.1046(a)	1640 Watts E.I.R.P	Complies
Occupied Bandwidth		2.1049(h)	Input/Output	Complies
Spurious Emissions at Antenna Terminals	24.238(a)	2.1051	-13dBm	Complies
Field Strength of Spurious Emissions	24.238(a)	2.1053	-13dBm E.I.R.P	Complies
Frequency Stability		2.1055(a)(d)	Must stay in band	NA

Name of Test	IC Para. No.	IC Method	Result
RF Power Output	RSS-133 6.4	RSS-GEN 4.8	Complies
Occupied Bandwidth	RSS-Gen 4.6	RSS-GEN 4.6.1	Complies
Spurious Emissions at Antenna Terminals	RSS-133 6.5	RSS-GEN 4.9	Complies
Field Strength of Spurious Emissions	RSS-133 6.5	RSS-GEN 4.9 SRSP-513	Complies
Frequency Stability	RSS-133 6.3	RSS-GEN 4.7	NA

Frequency stability is given by: The system gets an electrical analog signal from the BSS which is converted into an analog optical signal, transmitted by the optical links and then reconverted in the Remote Unit into an analog electrical signal. During this process happens no frequency change/modification, so input and output have same frequency what can be seen under clause "Occupied Bandwidth".



1 Equipment under test (E.U.T.)

1.1 Description

Kind of equipment	ION-U L 7/8/85/17P/19P Vac
Andrew Ident. Number	Id. No. 7669582-00
Serial no.(SN)	11
Revision	00
Software version and ID	n. a.
Type of modulation and Designator	F3E (Voice) <input checked="" type="checkbox"/> GSM (GXW) <input checked="" type="checkbox"/> GSM-EDGE (G7W) <input checked="" type="checkbox"/> CDMA (F9W) <input checked="" type="checkbox"/> W-CDMA (F9W) <input checked="" type="checkbox"/> LTE (G7D) <input checked="" type="checkbox"/>
Frequency Translation	F1-F1 <input checked="" type="checkbox"/> F1-F2 <input type="checkbox"/> N/A <input type="checkbox"/>
Band Selection	Software <input type="checkbox"/> Duplexer <input checked="" type="checkbox"/> Full band <input type="checkbox"/>

1.1.1 Downlink

Pass band	1930 MHz – 1995 MHz
Max. composite output power based on one carrier (rated)	33 dBm = 2 W
Gain	53 dB

1.1.2 Uplink

Pass band	1850 MHz – 1915 MHz
Gain	n. a.

Note: The EUT does not transmit over the air in the uplink direction.

1.1.3 Description of EUT

ION-U L 7/8/85/17P/19P Vac is a multi-band, multi-operator remote unit configuration used in conjunction with a master unit in the ION optical distribution system.

This system transports up to five frequency bands simultaneously (700 MHz, 800MHz, 850 MHz, 1900 MHz, 1700MHz), providing a cost-effective solution for distributing capacity from one or more base stations.

The ION-U L 7/8/85/17P/19P Vac Repeater consists of one 700 MHz, one 800 MHz, one 850 MHz, one 1900 MHz and one 1700 MHz (2100MHz in DL) path, with the intended use of simultaneous transmission. This Test Report describes only the approval of the 1900 MHz path



1.1.4 Block diagram of measurement reference points

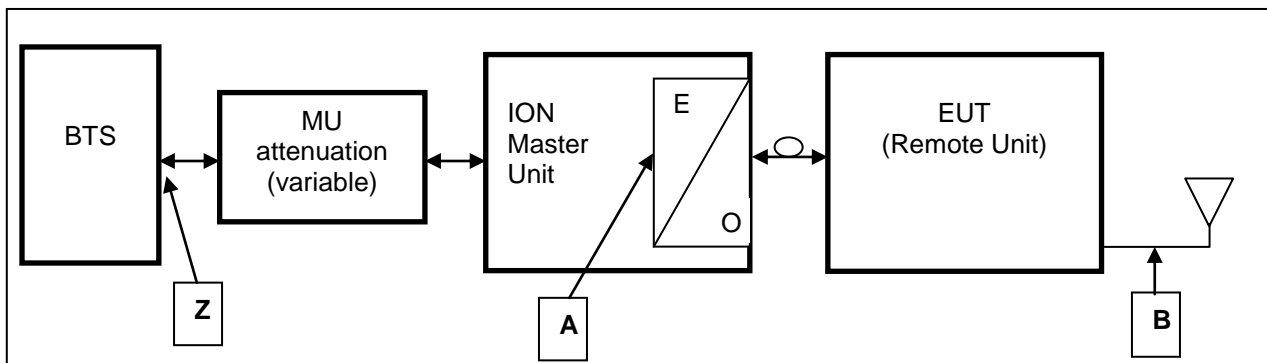

figure 1.1.4-#1 Block diagram of measurement reference points

Remote Unit is the EUT

O/E Optical / Electrical converter
 SRMU Sub Rack Master Unit

Reference point A SRMU UL output, DL input
 Reference point B Remote Unit DL output, UL input
 Reference point Z BTS DL output, UL input

Downlink: Measure from reference point A to B

Since a signal generator does not supply a good output signal with +33 or +43dBm, for the downlink measurement the MU Attenuation is not used.

That means for downlink measurements the signal generator is connected to measurement point A at the master optical / electrical converter and the analyzer to the measurement point B at the RU.

1.1.5 Downlink System Gain and Output Power

System optimized for BTS power (fixed value) Z	MU Attenuation (manual leveling)	Maximum rated input power at the MU OTRX (fixed value) A	RU Gain (fixed value) A to B	Maximum rated output power at RU Antenna port (fixed value) B
+33 dBm	53 dB	-20 dBm	+53 dB	+33.0 dBm @ 1 carrier
System Gain Z to A	0 dB			
+43 dBm	63 dB	-20 dBm	+53 dB	+33.0 dBm @ 1 carrier
System Gain Z to A	-10 dB			

table 1.1.5-#1 Equipment under test (E.U.T.) Description Downlink System Gain and Output Power



2 Test site (Andrew Buchdorf)

2.1 Test environment

All tests were performed under the following environmental conditions:

Condition	Minimum value	Maximum value
Barometric pressure	86 kPa	106 kPa
Temperature	15°C	30°C
Relative Humidity	20 %	75 %
Power supply range	±5% of rated voltages	

2.2 Test equipment

ANDREW Inv. No.	Test equipment	Type	Manufacturer	Serial No.	Calibration
9102	Network Analyzer	ZVB14	R&S	100118	08/13
9126	Spectrum Analyzer	FSV30	R&S	101237	11/13
9046	Signal Generator	SMBV100A	R&S	255090	06/13
8849	Signal Generator	SMU200A	R&S	101732	04/13
8671	Power Meter	E4418B	Agilent	GB39513094	06/13
8672	Power Sensor	E9300H	Agilent	US41090179	06/13
7321	Circulator	E10-1FFF	AEROTEK	25350	CIU
7326	Circulator	E10-1FFF	AEROTEK	25360	CIU
7408	RF-Cable	2,0m; N-N	Andrew	---	CIU
7409	RF-Cable	2,0m; N-N	Andrew	---	CIU
7410	RF-Cable	1,0m; N-N	Andrew	---	CIU
7411	RF-Cable	2,0m; N-N	Andrew	---	CIU
7373	RF-Cable	Multiflex141	Andrew	---	CIU
7374	RF-Cable	Multiflex141	Andrew	---	CIU
7437	RF-Cable	Multiflex141	Andrew	---	CIU
7438	RF-Cable	Multiflex141	Andrew	---	CIU
7439	RF-Cable	Multiflex141	Andrew	---	CIU
7443	RF-Cable	Multiflex141	Andrew	---	CIU
7444	RF-Cable	Multiflex141	Andrew	---	CIU
7445	RF-Cable	Multiflex141	Andrew	---	CIU
7446	RF-Cable	Multiflex141	Andrew	---	CIU
7447	RF-Cable	Multiflex141	Andrew	---	CIU
7448	RF-Cable	Multiflex141	Andrew	---	CIU
7449	RF-Cable	Multiflex141	Andrew	---	CIU
7450	RF-Cable	Multiflex141	Andrew	---	CIU
7440	RF-Cable	RG-223 0.8m	Andrew	---	CIU
7441	RF-Cable	RG-223 0.8m	Andrew	---	CIU
7453	RF-Cable	RG223 2m SMA.	Andrew	---	CIU
7454	RF-Cable	RG223 2m SMA.	Andrew	---	CIU
7455	RF-Cable	RG223 2m SMA.	Andrew	---	CIU
7144	Attenuator	2N-20dB	Inmet 64671	---	CIU
7341	Power Attenuator	768-20	Narda	---	CIU
7368	Matrix		COMMSCOPE	---	weekly

CIU = Calibrate in use

Test Report No.: 13-050

FCC ID: XS5-U7885L1719P

IC ID: 2237E-U7885L1719P



**BUREAU
VERITAS**

2.3 Input and output losses

All recorded power levels should be referenced to the input and output connectors of the repeater, unless explicitly stated otherwise.

The test equipment used in this test has to be calibrated, so that the functionality is also checked. All cables, attenuators, splitter, isolator, circulator and combiner etc. must be measured before testing and used for compensation during testing.

2.4 Measurement uncertainty

The extended measurement uncertainty corresponds to the measurement results from the standard measurement uncertainty multiplied by the coverage factor $k=2$. The true value is located in the corresponding interval with a probability of 95 %.

3 Test site (Bureau Veritas Consumer Product Services)

FCC Test site:

IC OATS:

See relevant dates under section 8.



4 RF Power Out: §24.232, §2.1046

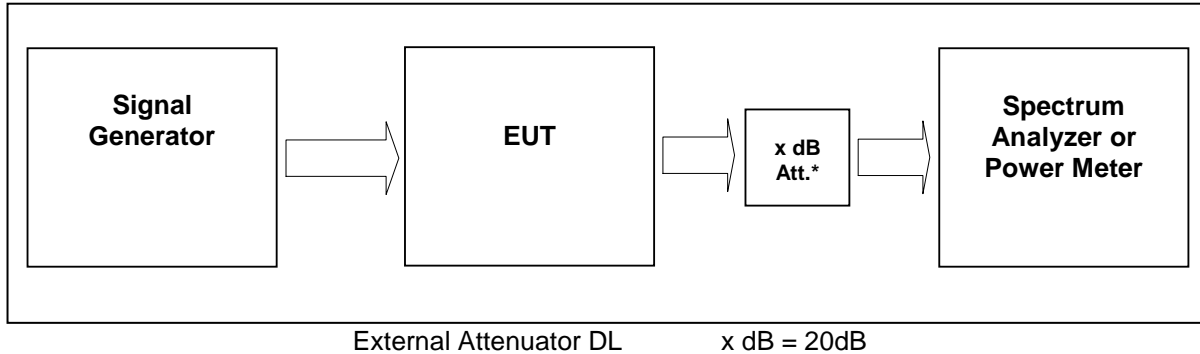

figure 2.4-#1 Test setup: RF Power Out: §24.232, §2.1046

Measurement uncertainty	± 0,38 dB
Test equipment used	9126, 9046, 7444; 7321; 7144; 7454;7453; 7341; 7449; 7368

4.1 Limit

Minimum standard:

Para. No.24.232

(a)(1) Base stations with an emission bandwidth of 1 MHz or less are limited to 1640 watts equivalent isotropically radiated power (EIRP) with an antenna height up to 300 meters HAAT, except as described in paragraph (b) below.

(2) Base stations with an emission bandwidth greater than 1 MHz are limited to 1640 watts/MHz equivalent isotropically radiated power (EIRP) with an antenna height up to 300 meters HAAT, except as described in paragraph (b) below.

Table 1—Reduced Power for Base Station Antenna Heights Over 300 Meters

HAAT in meters	Maximum EIRP watts
≤ 300	1640
≤ 500	1070
≤ 1000	490
≤ 1500	270
≤ 2000	160

4.2 Test method

§ 2.1046 Measurements required: RF power output.

(a) For transmitters other than single sideband, independent sideband and controlled carrier radiotelephone, power output shall be measured at the RF output terminals when the transmitter is adjusted in accordance with the tune-up procedure to give the values of current and voltage on the circuit elements specified in § 2.1033(c)(8). The electrical characteristics of the radio frequency load attached to the output terminals when this test is made shall be stated.

Test Report No.: 13-050

FCC ID: XS5-U7885L1719P

IC ID: 2237E-U7885L1719P



**BUREAU
VERITAS**

(c) For measurements conducted pursuant to paragraphs (a) and (b) of this section, all calculations and methods used by the applicant for determining carrier power or peak envelope power, as appropriate, on the basis of measured power in the radio frequency load attached to the transmitter output terminals shall be shown. Under the test conditions specified, no components of the emission spectrum shall exceed the limits specified in the applicable rule parts as necessary for meeting occupied bandwidth or emission limitations

4.3 Test results

Detector RMS.

Test signal Analog:

FM signal with 3.0 kHz deviation and 2.5 kHz rate and sine waveform

Test signal GSM:

Signal waveform with GMSK modulation in all time slots according to 3GPP TS45.004

Test signal GSM EDGE:

Signal waveform with 8-PSK modulation in all time slots according to 3GPP TS45.004

Test signal CDMA:

Signal waveform according to table 6.2-1 of standard specification 3GPP2 C.p0051-0 v1.0 16.February 2006 pilot, sync, paging, 37 traffics, which is equal to the table 6.5.2.1 of 3GPP2 C.S0010-C v2.0 24.February 2006.

Test signal WCDMA:

Signal waveform according to Test Model 1 of standard specification 3GPP TS25.141. Signal modulated with a combination of PCCPCH, SCCPCH and Dedicated Physical Channels specified as test model 1 64 DPCH.

Test signal LTE:

Signal waveform according to Test Model 1.1, E-TM1.1, clause 6.1.1.1-1, table 6.1.1.1-1 of standard specification 3GPP TS 36.141 V9.3.0 (2010-03).



4.3.1 Downlink

Modulation	Measured at	RBW VBW Span	RF Power (dBm)	RF Power (W)	Plot -
Analog	1962,5MHz	0.1MHz 0.3MHz 1.5MHz	33	2	4.3.1.1 #1
GSM	1962,5 MHz	1MHz 3MHz 10MHz	33	2	4.3.1.2 #1
GSM- EDGE	1962,5 MHz	1MHz 3MHz 10MHz	33	2	4.3.1.3 #1
CDMA	1962,5 MHz	3MHz 10MHz 15MHz	33	2	4.3.1.4 #1
WCDMA	1962,5 MHz	10MHz 10MHz 50MHz	33	2	4.3.1.5 #1
LTE	1962,5 MHz	10MHz 10MHz 50MHz	33	2	4.3.1.6 #1
Maximum output power = 33 dBm = 2 W					
Limit Maximum output power (eirp) = 1640 W					

table 4.3.1-#1 RF Power Out: §24.232, §2.1046 Test results Downlink

The max RF Power out is 33 dBm, so the maximum antenna gain (x) can be calculated as follow:

Limit = 1000W (erp) = 60 dBm

Info: 1000W (erp) = 1640W (eirp)

60 dBm > 33 dBm + x

27.0 dBd = 29.15 dBi > x

=> The antenna that will use for the complete system have to have a gain lower than 29 dBi, relative to a dipol.

Modulation	Pin / dBm (Ref. point B)
Analog	-22.5
GSM	-22.4
EDGE	-22.4
CDMA	-22.5
WCDMA	-22.5
LTE	-22.5

table 4.3.1-#2 RF Power Out: §24.232, §2.1046 Test results Downlink Input power



4.3.1.1 Analog

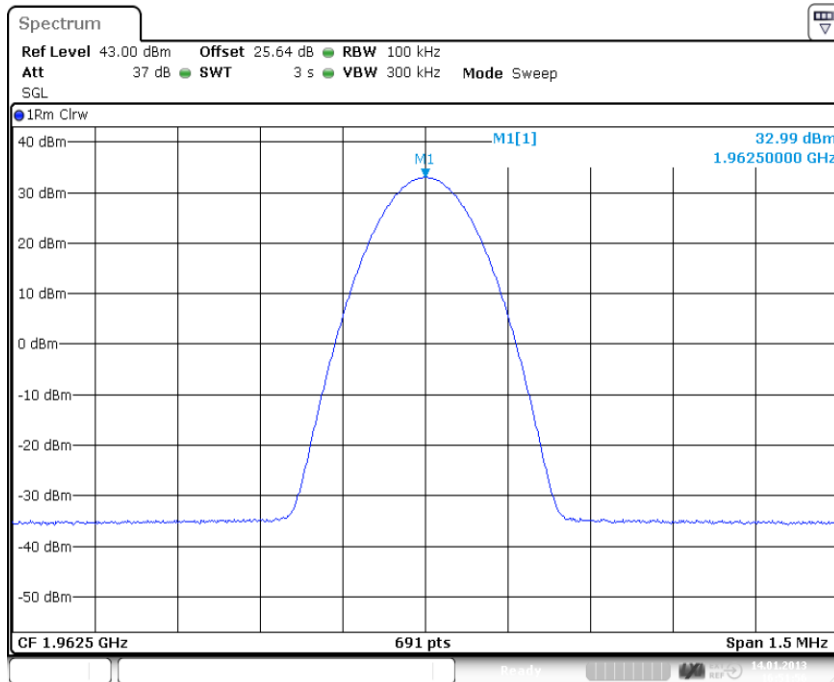

Date: 14.JAN.2013 16:51:56

plot 4.3.1.1-#1 RF Power Out: §24.232, §2.1046; Test results; Downlink; Analog Middle

4.3.1.2 GSM

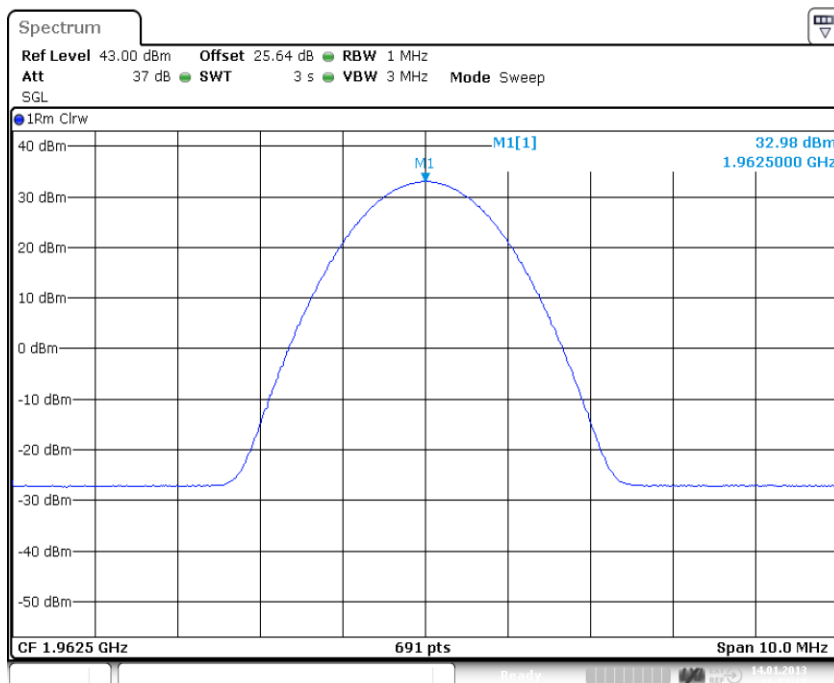

Date: 14.JAN.2013 16:57:14

plot 4.3.1.2-#1 RF Power Out: §24.232, §2.1046; Test results; Downlink; GSM Middle



4.3.1.3 EDGE

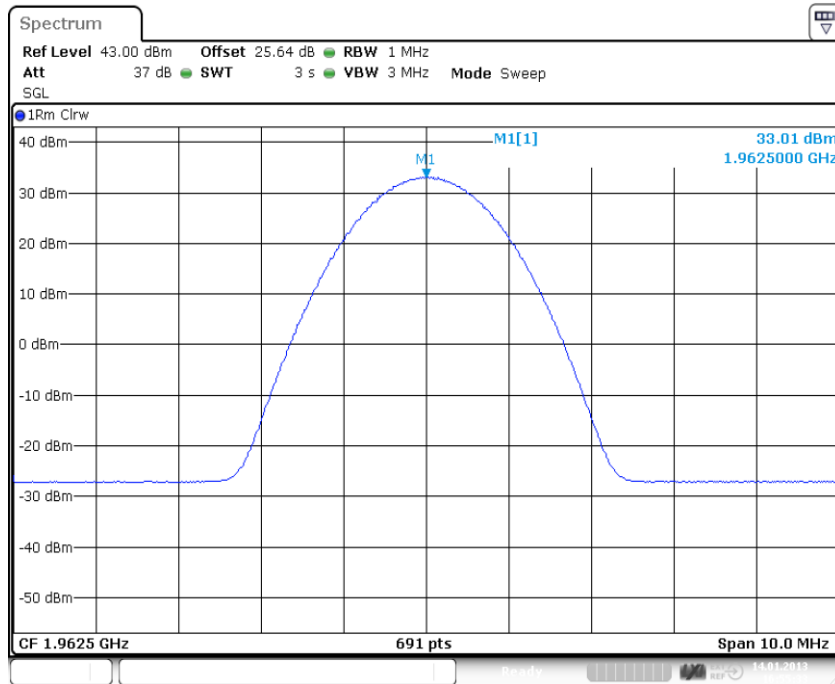

Date: 14.JAN.2013 16:55:33

plot 4.3.1.3-#1 RF Power Out: §24.232, §2.1046; Test results; Downlink; EDGE Middle

4.3.1.4 CDMA

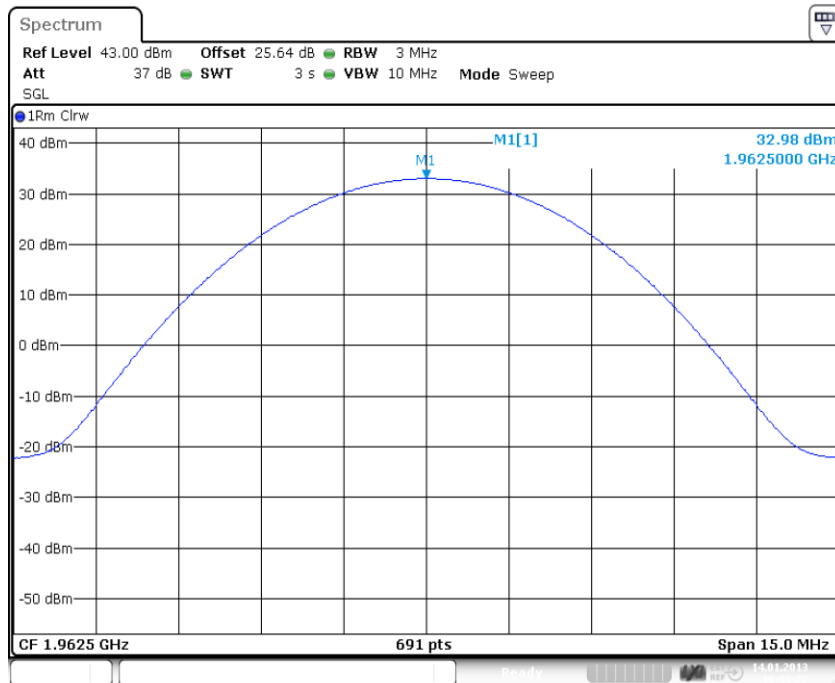

Date: 14.JAN.2013 16:53:26

plot 4.3.1.4-#1 RF Power Out: §24.232, §2.1046; Test results; Downlink; CDMA Middle



4.3.1.5 W-CDMA

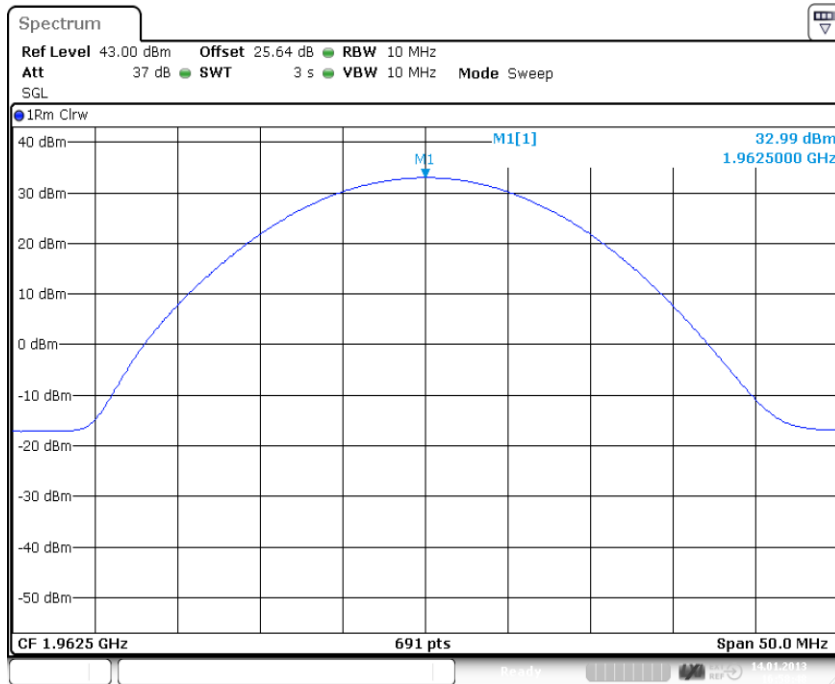

Date: 14.JAN.2013 16:58:48

plot 4.3.1.5-#1 RF Power Out: §24.232, §2.1046; Test results; Downlink; W-CDMA Middle

4.3.1.6 LTE

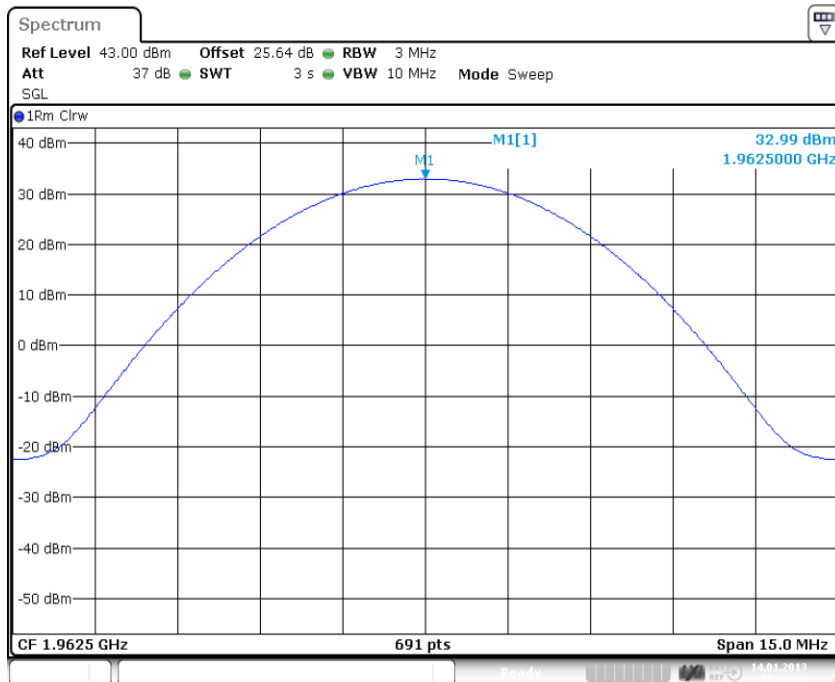

Date: 14.JAN.2013 15:10:04

plot 4.3.1.6-#1 RF Power Out: §24.232, §2.1046; Test results; Downlink; LTE Middle

Test Report No.: 13-050

FCC ID: XS5-U7885L1719P

IC ID: 2237E-U7885L1719P



**BUREAU
VERITAS**

4.3.2 Uplink

n.a.

Note: The EUT does not transmit over the air in the uplink direction.

4.4 Summary test result

Test result	complies, according the plots above
Tested by:	M. Leinfelder
Date:	14.01.2013



5 Occupied Bandwidth: §2.1049

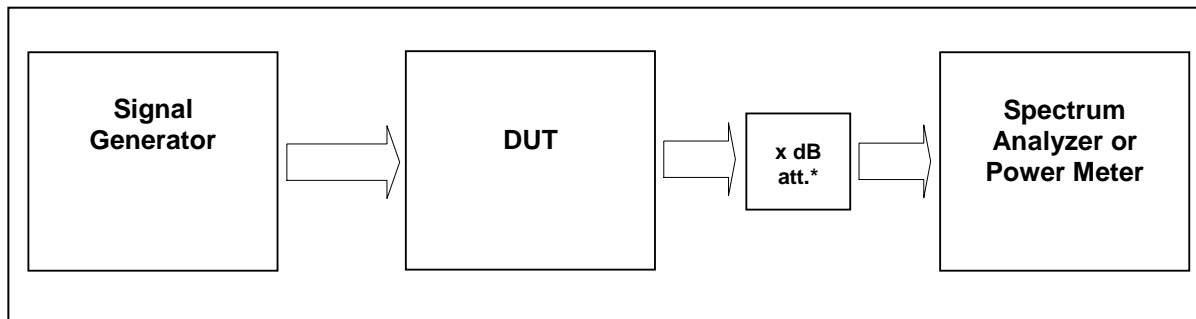

External Attenuator DL x dB = 20 dB
figure 4.4-#1 Test setup: Occupied Bandwidth: §2.1049

Measurement uncertainty	± 0,38 dB
Test equipment used	9126, 9046, 7444; 7321; 7144; 7454;7453; 7341; 7449; 7368

5.1 Limit

The spectral shape of the output should look similar to input for all modulations.

5.2 Test method

Para. No.2.1049

The occupied bandwidth, that is the frequency bandwidth such that, below its lower and above its upper frequency limits, the mean powers radiated are each equal to 0.5 percent of the total mean power radiated by a given emission shall be measured under the following conditions as applicable:

(h) Transmitters employing digital modulation techniques—when modulated by an input signal such that its amplitude and symbol rate represent the maximum rated conditions under which the equipment will be operated. The signal shall be applied through any filter networks, pseudo-random generators or other devices required in normal service. Additionally, the occupied bandwidth shall be shown for operation with any devices used for modifying the spectrum when such devices are optional at the discretion of the user.



5.3 Test results

5.3.1 Downlink

Detector RMS.

Modulation	Measured at	Carrier /MHz	RBW VBW Span	Occupied Bandwidth	Plot #
Analog	Middle	1962,5MHz	1 kHz 10 kHz 125 kHz	0.0090 MHz	5.3.1.1 #1, #2
GSM	Middle	1962,5 MHz	3kHz 30kHz 1MHz	0.192 MHz	5.3.1.2 #1, #2
GSM-EDGE	Middle	1962,5 MHz	3kHz 30kHz 1MHz	0.192 MHz	5.3.1.3 #1, #2
CDMA	Middle	1962,5 MHz	30 kHz 300 kHz 5 MHz	1.172 MHz	5.3.1.4 #1, #2
WCDMA	Middle	1962,5 MHz	100kHz 1MHz 10MHz	3.777 MHz	5.3.1.5 #1,#2
LTE	Middle	1962,5 MHz	30 kHz 300 kHz 5 MHz	1.042 MHz	5.3.1.6 #1,#2

table 5.3-#1 Occupied Bandwidth: §2.1049 Test results Downlink



5.3.1.1 Analog

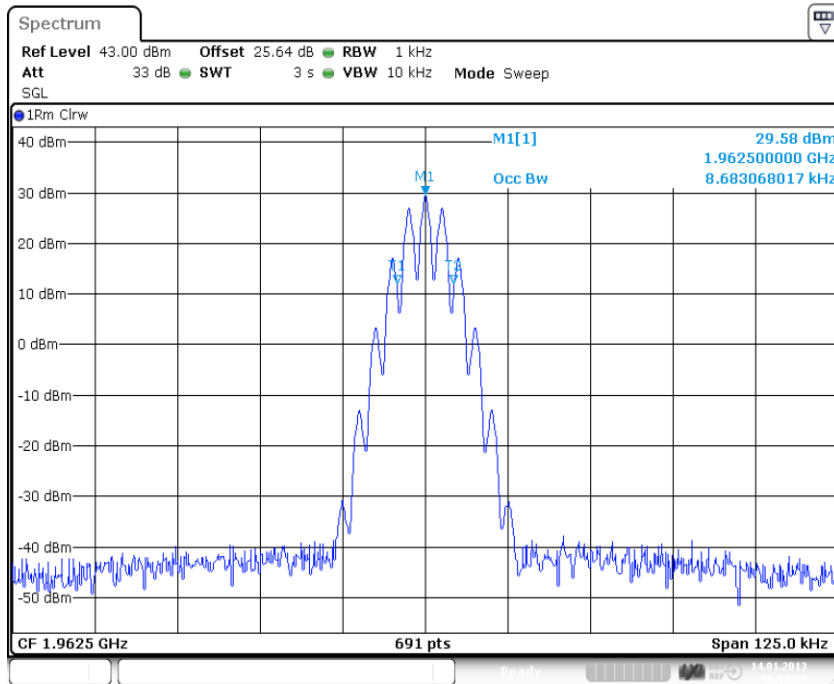

Date: 14.JAN.2013 16:52:05

plot 5.3.1.1-#1 Occupied Bandwidth: §2.1049; Test results; Downlink; Analog Output

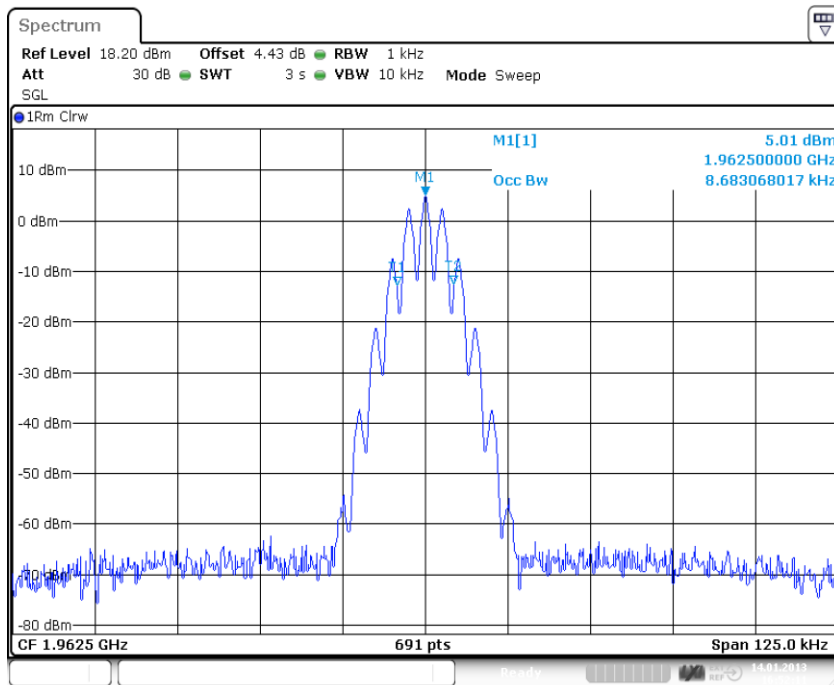

Date: 14.JAN.2013 16:52:10

plot 5.3.1.1-#2 Occupied Bandwidth: §2.1049; Test results; Downlink; Analog Input



5.3.1.2 GSM

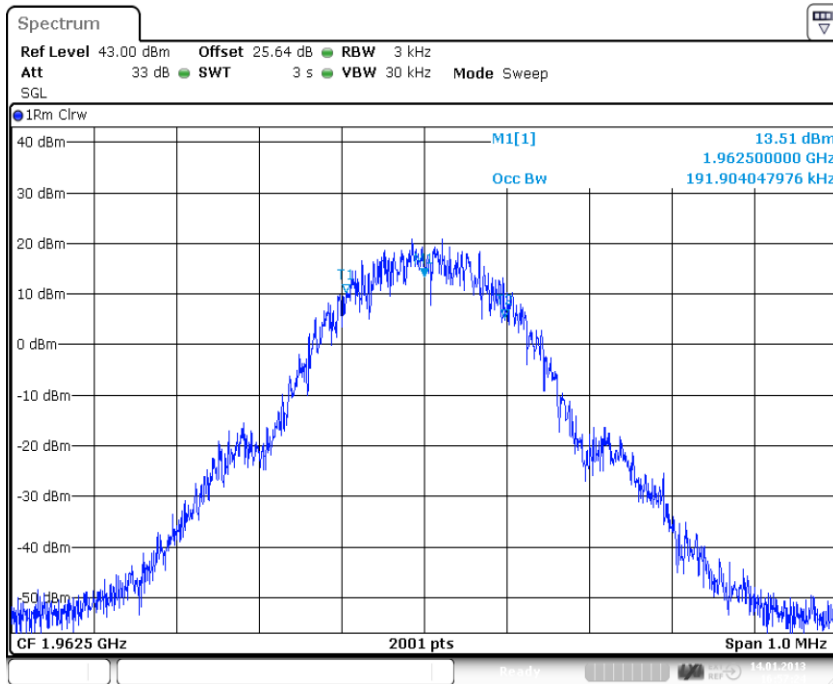

Date: 14.JAN.2013 16:57:24

plot 5.3.1.2-#1 Occupied Bandwidth: \$2.1049; Test results; Downlink; GSM Output

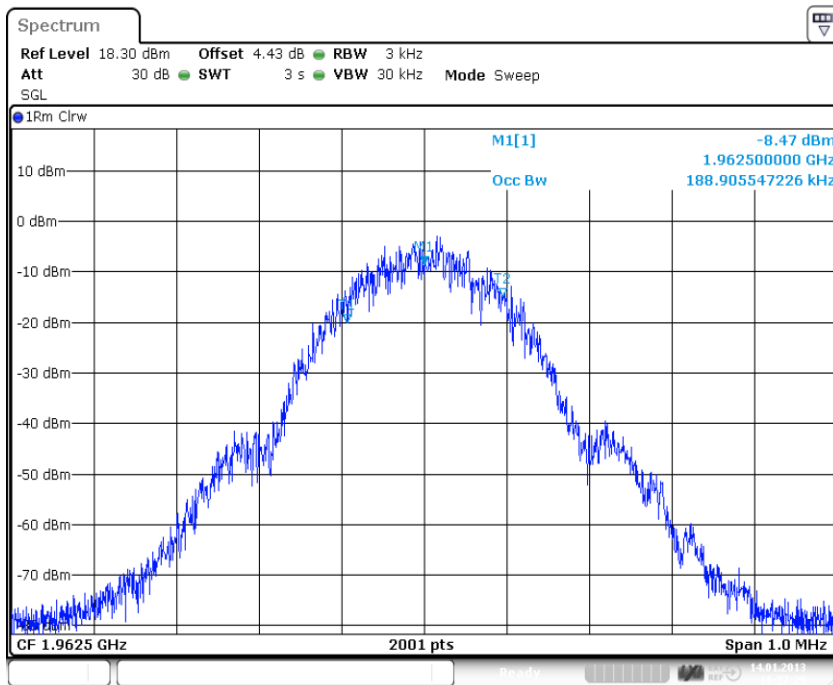

Date: 14.JAN.2013 16:57:29

plot 5.3.1.2-#2 Occupied Bandwidth: \$2.1049; Test results; Downlink; GSM Input



5.3.1.3 EDGE

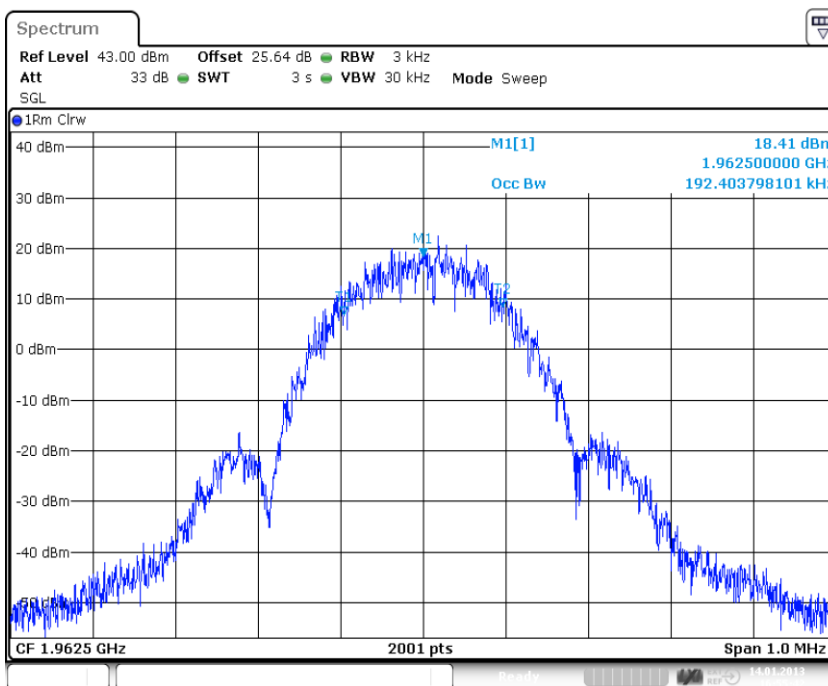

Date: 14.JAN.2013 16:55:42

plot 5.3.1.3-#1 Occupied Bandwidth: \$2.1049; Test results; Downlink; EDGE Output

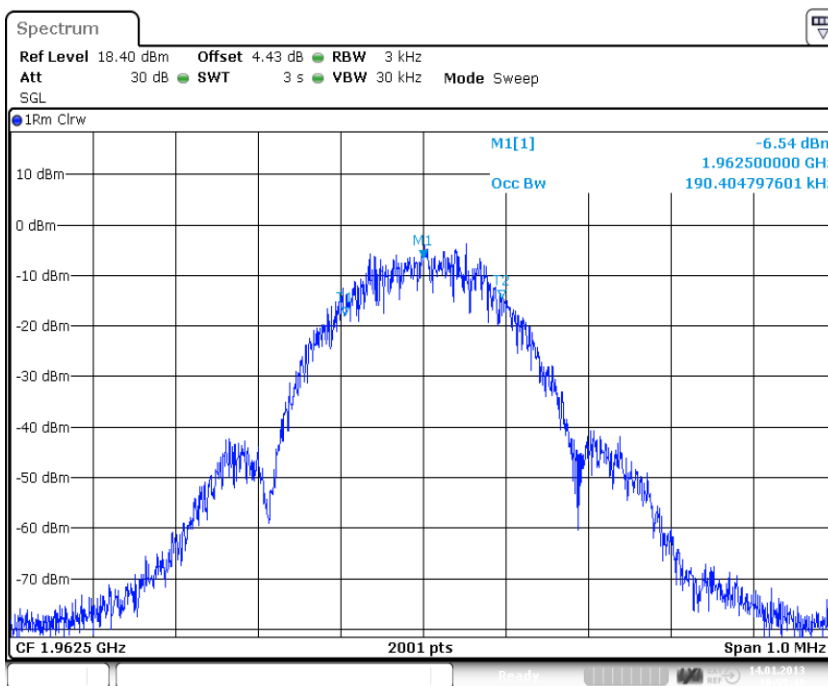

Date: 14.JAN.2013 16:55:47

plot 5.3.1.3-#2 Occupied Bandwidth: \$2.1049; Test results; Downlink; EDGE Input



5.3.1.4 CDMA

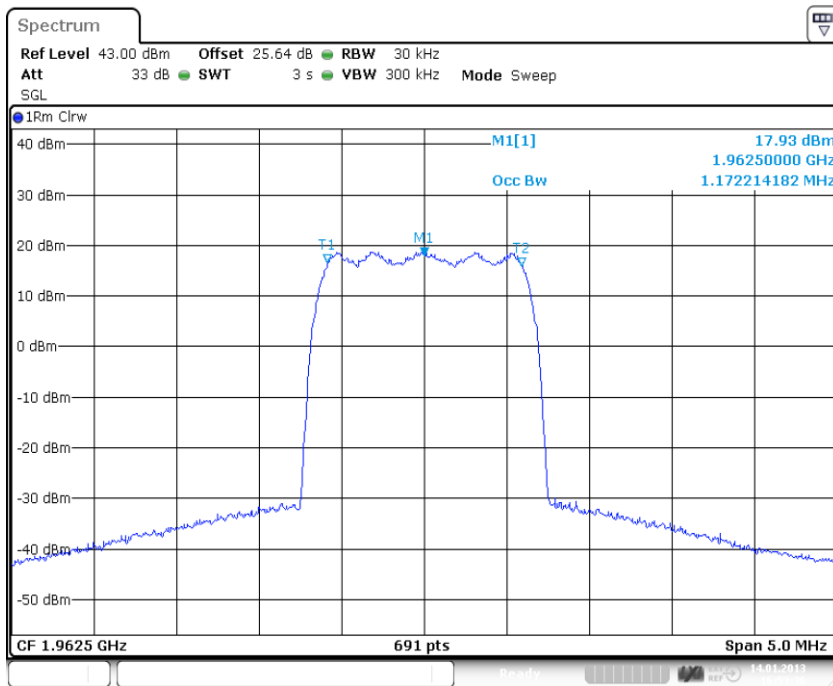

plot 5.3.1.4-#1 Occupied Bandwidth: \$2.1049; Test results; Downlink; CDMA Output

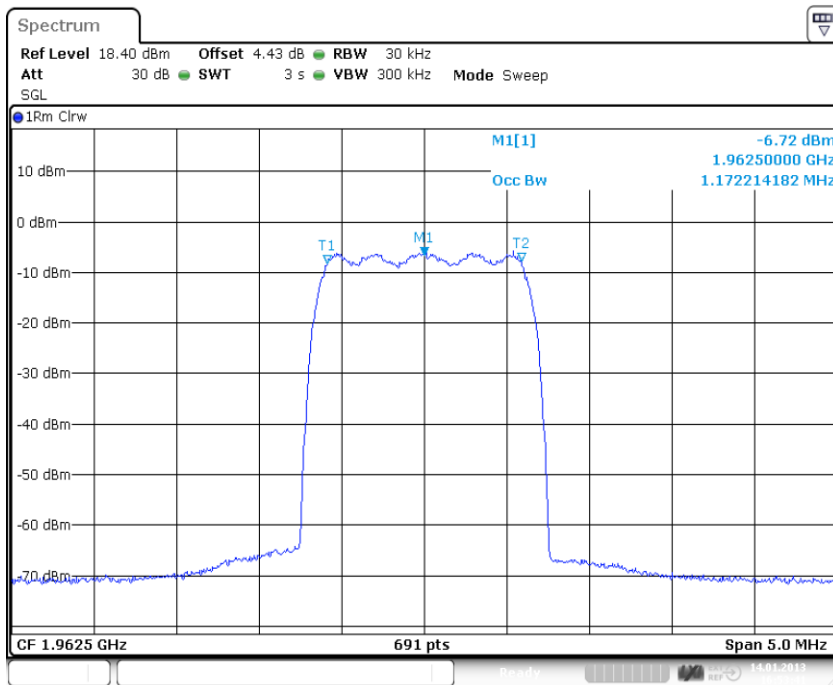

plot 5.3.1.4-#2 Occupied Bandwidth: \$2.1049; Test results; Downlink; CDMA Input



5.3.1.5 W-CDMA

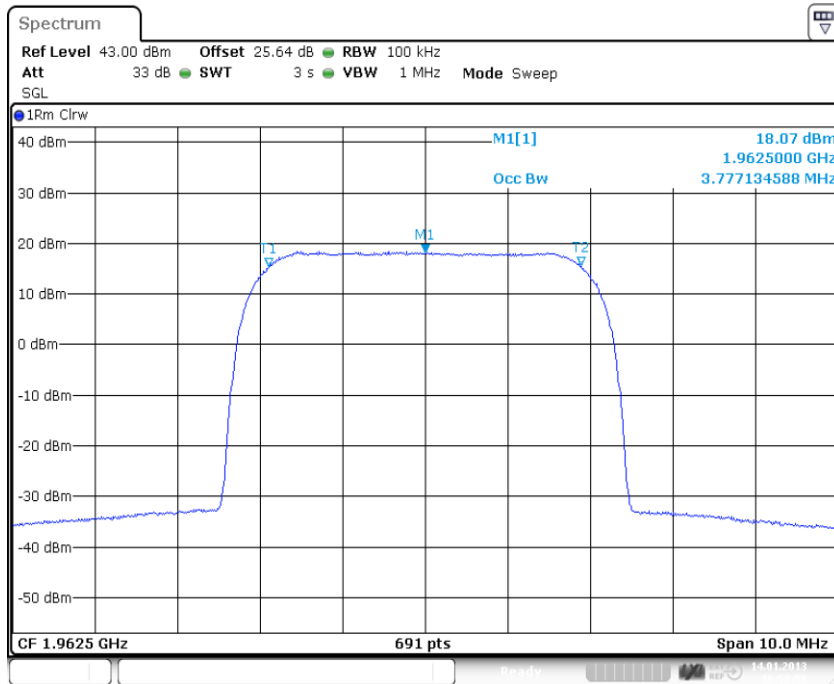

plot 5.3.1.5-#1 Occupied Bandwidth: §2.1049; Test results; Downlink; W-CDMA Output

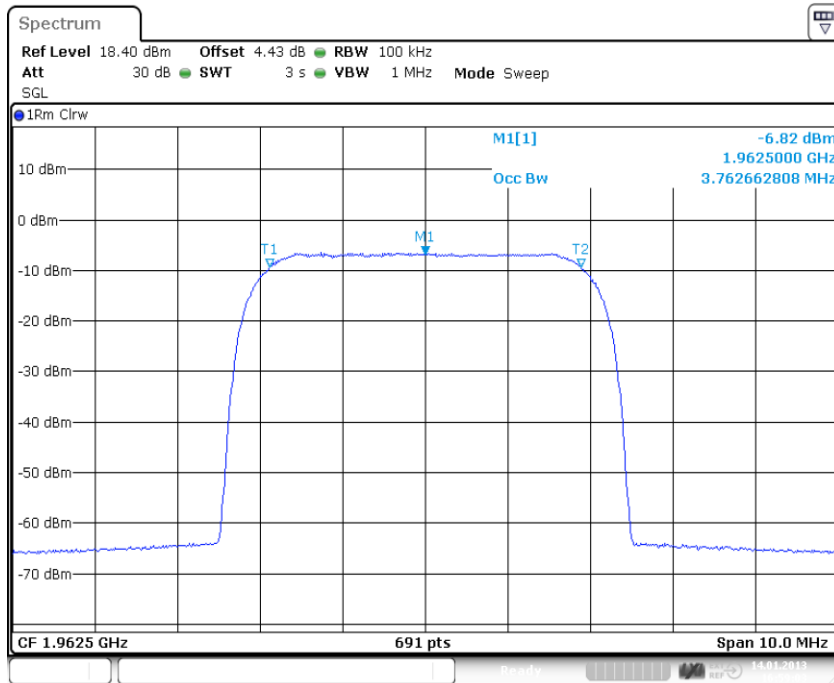

plot 5.3.1.5-#2 Occupied Bandwidth: §2.1049; Test results; Downlink; W-CDMA Input



5.3.1.6 LTE

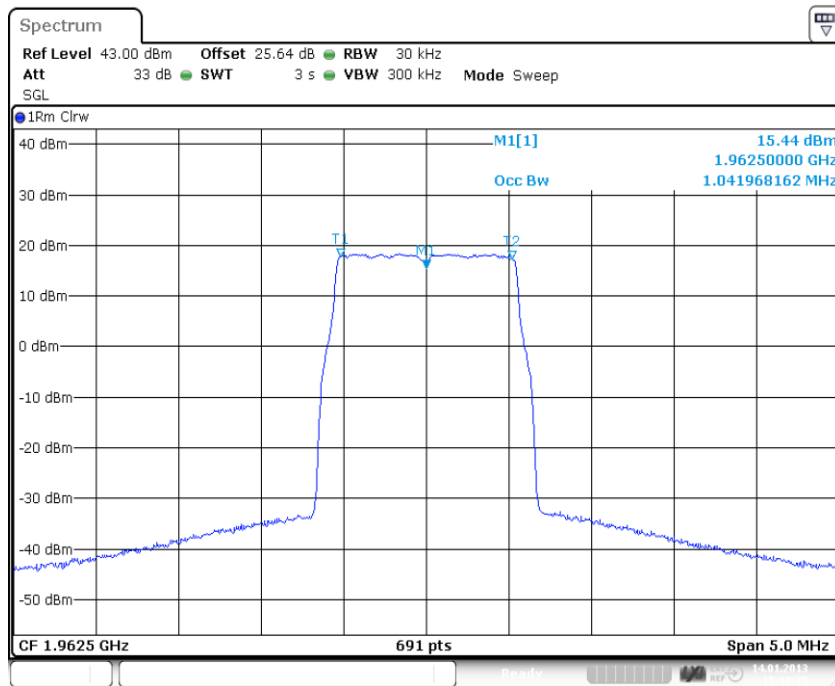

plot 5.3.1.6-#1 Occupied Bandwidth: 2.1049; Test results; Downlink; LTE Output

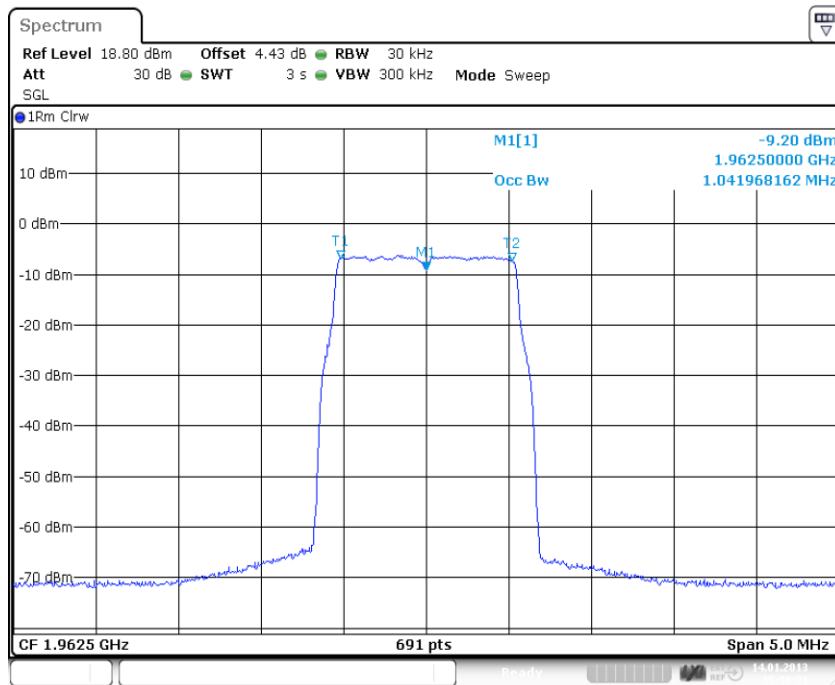

plot 5.3.1.6-#2 Occupied Bandwidth: 2.1049; Test results; Downlink; LTE Input

Test Report No.: 13-050

FCC ID: XS5-U7885L1719P

IC ID: 2237E-U7885L1719P



BUREAU
VERITAS

5.3.2 Uplink

n.a.

Note: The EUT does not transmit over the air in the uplink direction.

5.4 Summary test result

Test result	complies, according the plots above
Tested by:	M. Leinfelder
Date:	14.01.2013



6 Spurious Emissions at Antenna Terminals: §24.238, §2.1051

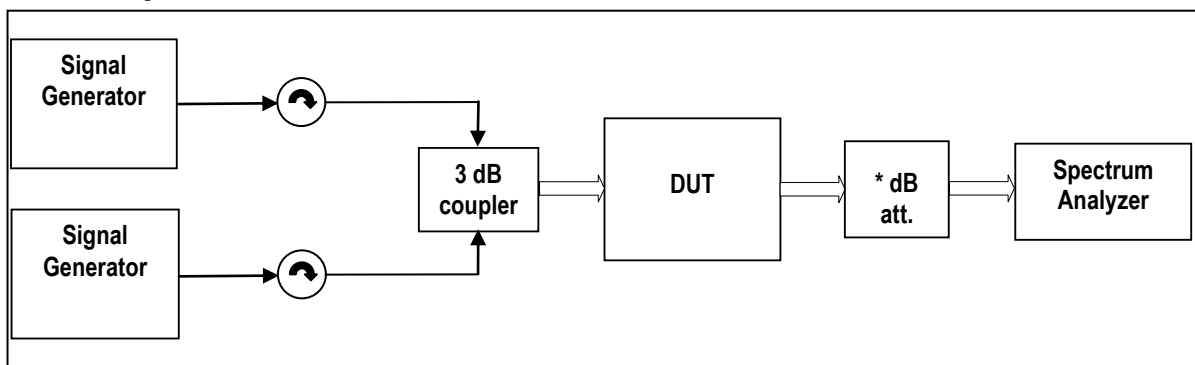

Multisignal-Generator used, External Attenuator DL x dB = 20 dB
 figure 6-#1 Test setup: Spurious Emissions at Antenna Terminals: §24.238, §2.1051

Measurement uncertainty	± 0,54 dB ± 1,2 dB ± 1,5 dB	9 kHz to 3 GHz 3 GHz to 7 GHz 7 GHz to 26 GHz
Test equipment used	9126, 9046, 8849; 7444; 7443; 7321; 7326; 7144; 7454; 7453; 7341; 7449; 7368	

6.1 Limit

Minimum standard:

Para. No.24.238(a)

The rules in this section govern the spectral characteristics of emissions in the Broadband Personal Communications Service.

(a) Out of band emissions. The power of any emission outside of the authorized operating frequency ranges must be attenuated below the transmitting power (P) by a factor of at least $43 + 10 \log(P)$ dB.

6.2 Test method

Para. No 2.1051 Measurements required: Spurious emissions at antenna terminals.

The radio frequency voltage or powers generated within the equipment and appearing on a spurious frequency shall be checked at the equipment output terminals when properly loaded with a suitable artificial antenna. Curves or equivalent data shall show the magnitude of each harmonic and other spurious emission that can be detected when the equipment is operated under the conditions specified in § 2.1049 as appropriate. The magnitude of spurious emissions which are attenuated more than 20 dB below the permissible value need not be specified.

[39 FR 5919, Feb. 15, 1974. Redesignated and amended at 63 FR 36599, July 7, 1998]



6.3 Test results

6.3.1 Downlink

<1MHz from Band Edge

Detector: RMS.

Modulation	Measured at Band Edge	Carriers	RBW VBW Span	Max. level (dBm)	Plot -
Analog	Lower Edge Upper Edge	1930,0125 MHz 1930,0375 MHz 1994,9625 MHz 1994,9875 MHz	0.3kHz 3kHz 1.1MHz	-33.5	6.3.1.1 #1 #2
GSM	Lower Edge Upper Edge	1930,4 MHz 1930,6 MHz 1994,4 MHz 1994,6 MHz	3kHz 30kHz 2MHz	-39.2	6.3.1.2 #1 #2
GSM-EDGE	Lower Edge Upper Edge	1930,4 MHz 1930,6 MHz 1994,4 MHz 1994,6 MHz	3kHz 30kHz 2MHz	-40.0	6.3.1.3 #1 #2
CDMA	Lower Edge Upper Edge	1930,775 MHz 1932,025 MHz 1992,975 MHz 1994,225 MHz	30kHz 300kHz 6MHz	-31.0	6.3.1.4 #1 #2
WCDMA	Lower Edge Upper Edge	1932,6 MHz 1937,6 MHz 1987,4 MHz 1992,4 MHz	100kHz 1MHz 15MHz	-33.9	6.3.1.5 #1 #2
LTE	Lower Edge Upper Edge	1930.7 MHz 1932.1 MHz 1992.9 MHz 1994.3 MHz	30kHz 300kHz 6MHz	-31.8	6.3.1.6 #1 #2

table 6.3-#1 Spurious Emissions at Antenna Terminals: §24.238, §2.1051 Test results Downlink <1MHz from Band Edge



>1MHz from Band Edge

Detector: RMS.

Modulation	Carrier at	Carrier	Max. level (dBm)	RBW VBW Frequency range	Plot -
Analog	Lower Edge Upper Edge	1930.0125 MHz 1994.9875 MHz	-28.7	1MHz 3MHz 30MHz – 20GHz	6.3.1.7 #1; #2
GSM	Lower Edge Upper Edge	1930.4 MHz 1994.6 MHz	-28.9	1MHz 3MHz 30MHz – 20GHz	6.3.1.8 #1; #2
GSM-EDGE	Lower Edge Upper Edge	1930.4 MHz 1994.6 MHz	-28.8	1MHz 3MHz 30MHz – 20GHz	6.3.1.9 #1; #2
CDMA	Lower Edge Upper Edge	1930.775 MHz 1994.225 MHz	-28.8	1MHz 3MHz 30MHz – 20GHz	6.3.1.10 #1; #2
WCDMA	Lower Edge Upper Edge	1932.6 MHz 1992.4 MHz	-29.1	1MHz 3MHz 30MHz – 20GHz	6.3.1.11 #1; #2
LTE	Lower Edge Upper Edge	1930.7 MHz 1994.3 MHz	-28.8	1MHz 3MHz 30MHz – 20GHz	6.3.1.12 #1; #2

table 6.3-#2 Spurious Emissions at Antenna Terminals: §24.238, §2.1051 Test results Downlink >1MHz from Band Edge



6.3.1.1 Analog < 1MHz to band edge

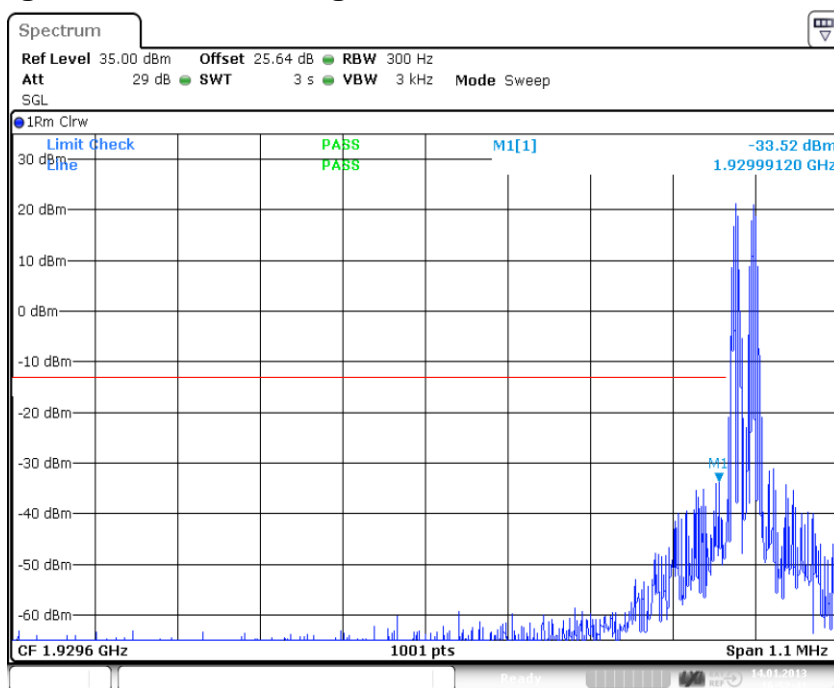

Date: 14.JAN.2013 16:52:41

plot 6.3.1.1-#1 Spurious Emissions at Antenna Terminals: §24.238, §2.1051; Test results; Downlink; Analog < 1MHz to band edge Lower Band Edge

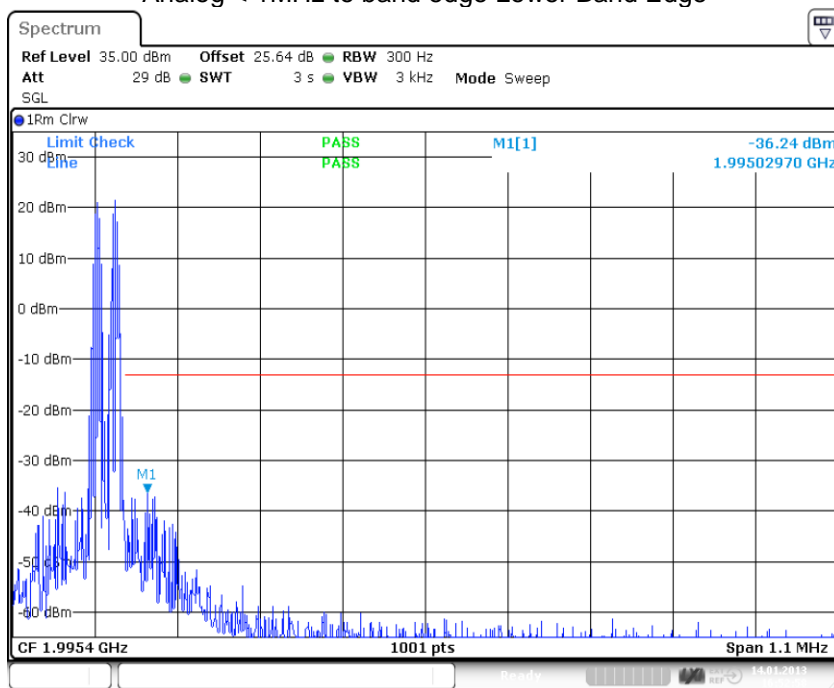

Date: 14.JAN.2013 16:52:58

plot 6.3.1.1-#2 Spurious Emissions at Antenna Terminals: §24.238, §2.1051; Test results; Downlink; Analog < 1MHz to band edge Upper Band Edge



6.3.1.2 GSM < 1MHz to band edge

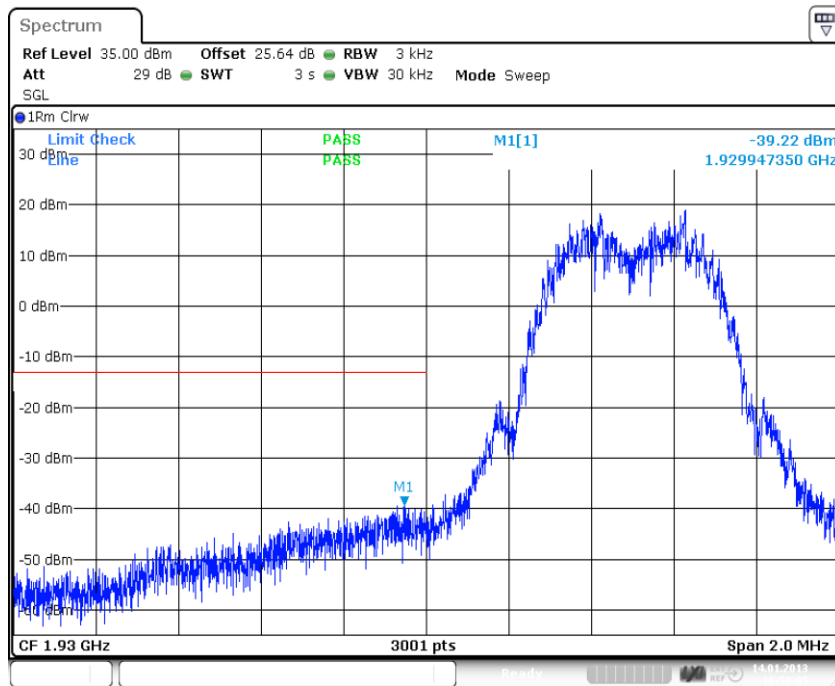

Date: 14.JAN.2013 16:58:05

plot 6.3.1.2-#1 Spurious Emissions at Antenna Terminals: §24.238, §2.1051; Test results; Downlink; GSM < 1MHz to band edge Lower Band Edge

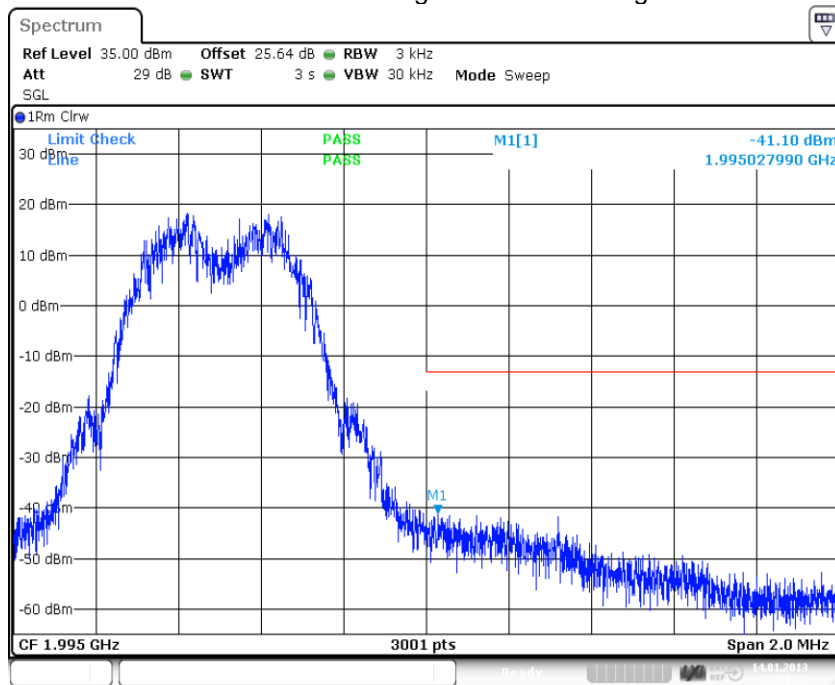

Date: 14.JAN.2013 16:58:21

plot 6.3.1.2-#2 Spurious Emissions at Antenna Terminals: §24.238, §2.1051; Test results; Downlink; GSM < 1MHz to band edge Upper Band Edge



6.3.1.3 EDGE < 1MHz to band edge

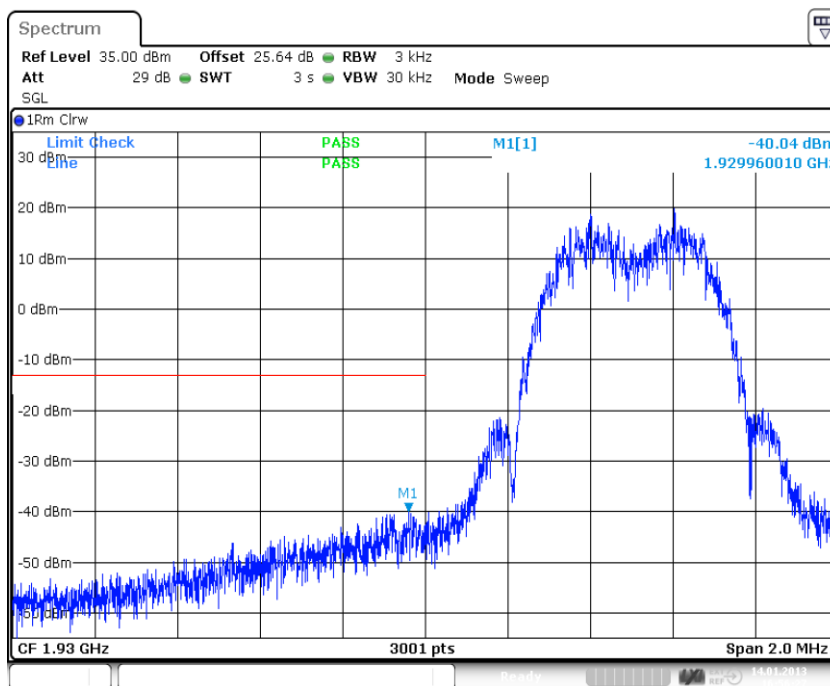

plot 6.3.1.3-#1 Spurious Emissions at Antenna Terminals: §24.238, §2.1051; Test results; Downlink; EDGE < 1MHz to band edge Lower Band Edge

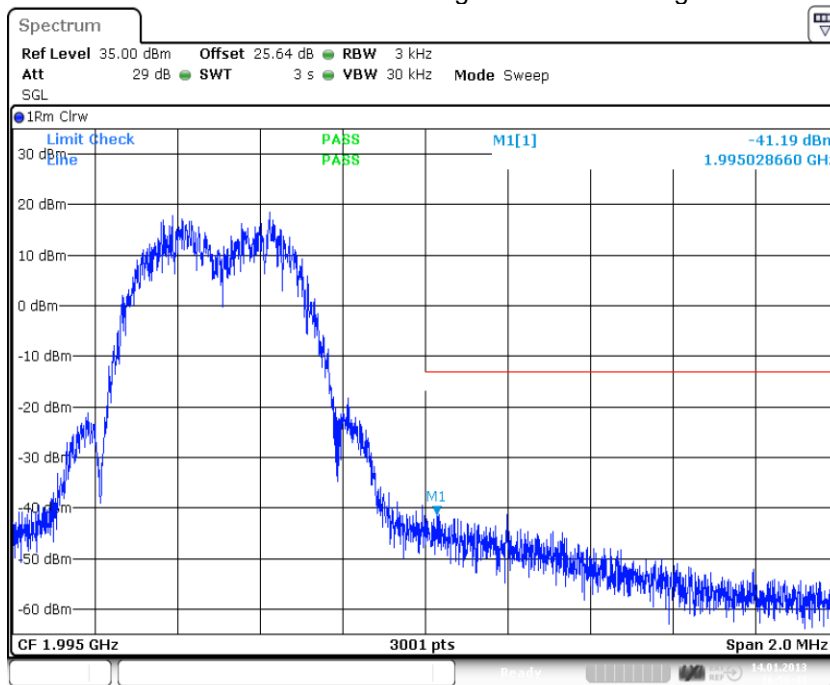

plot 6.3.1.3-#2 Spurious Emissions at Antenna Terminals: §24.238, §2.1051; Test results; Downlink; EDGE < 1MHz to band edge Upper Band Edge



6.3.1.4 CDMA < 1MHz to band edge

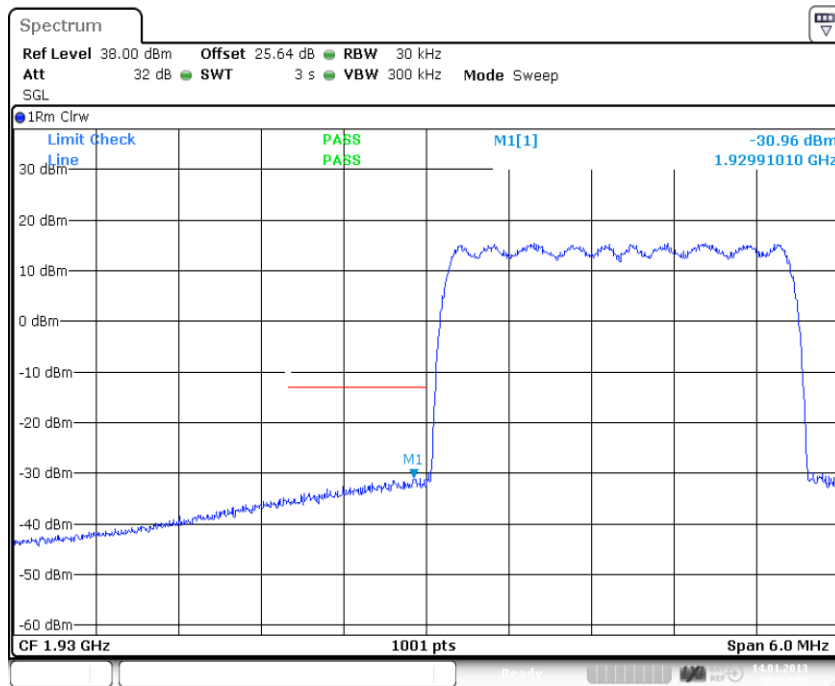

Date: 14.JAN.2013 16:54:53

plot 6.3.1.4-#1 Spurious Emissions at Antenna Terminals: §24.238, §2.1051; Test results; Downlink; CDMA < 1MHz to band edge Lower Band Edge

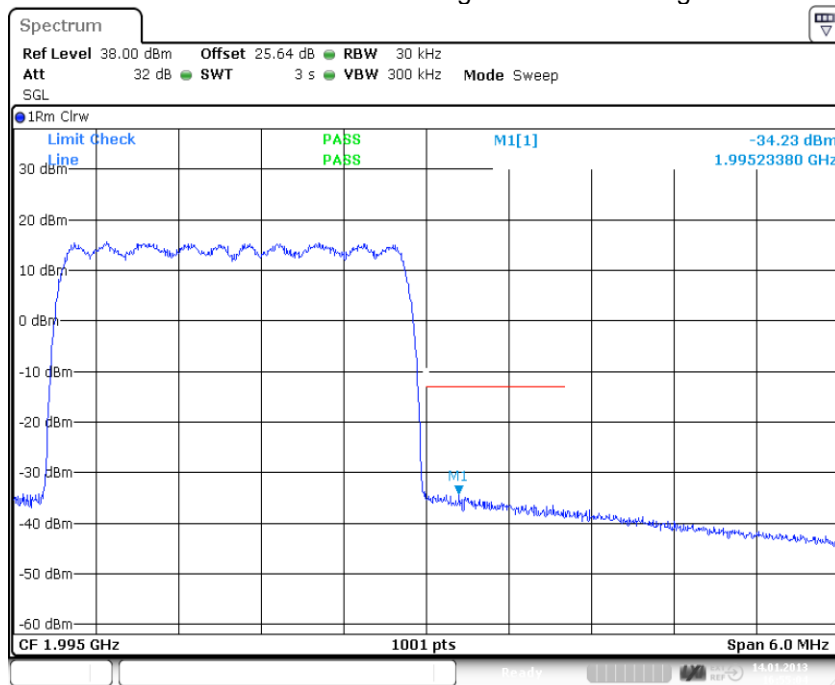

Date: 14.JAN.2013 16:55:04

plot 6.3.1.4-#2 Spurious Emissions at Antenna Terminals: §24.238, §2.1051; Test results; Downlink; CDMA < 1MHz to band edge Upper Band Edge



6.3.1.5 W-CDMA < 1MHz to band edge

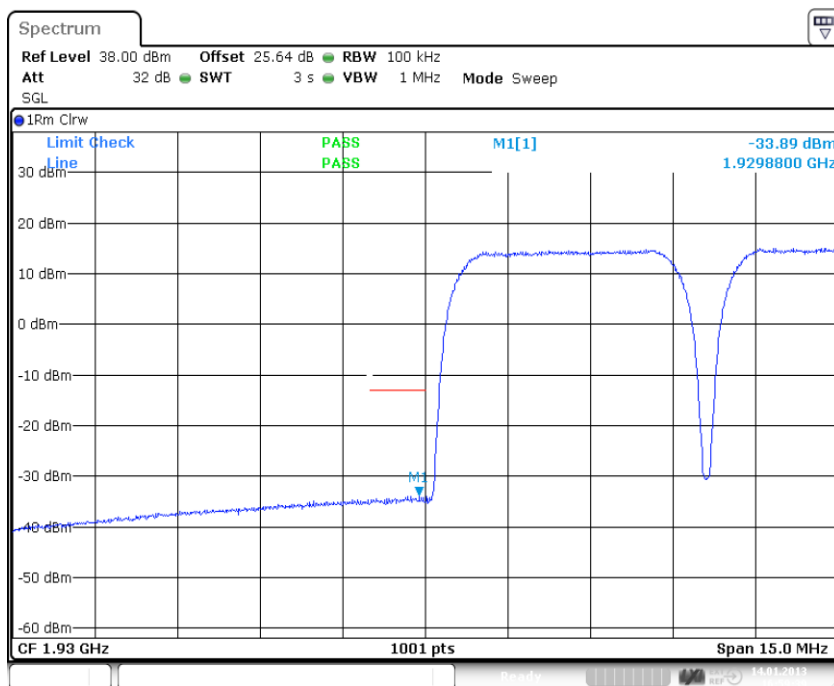

Date: 14.JAN.2013 16:59:39

plot 6.3.1.5-#1 Spurious Emissions at Antenna Terminals: §24.238, §2.1051; Test results; Downlink; W-CDMA < 1MHz to band edge Lower Band Edge

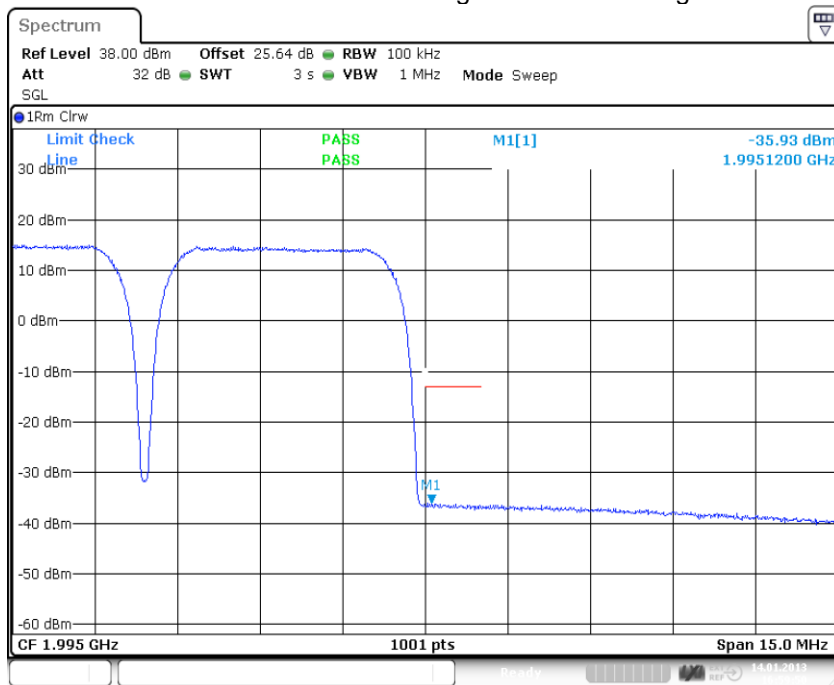

Date: 14.JAN.2013 16:59:50

plot 6.3.1.5-#2 Spurious Emissions at Antenna Terminals: §24.238, §2.1051; Test results; Downlink; W-CDMA < 1MHz to band edge Upper Band Edge



6.3.1.6 LTE < 1MHz to band edge

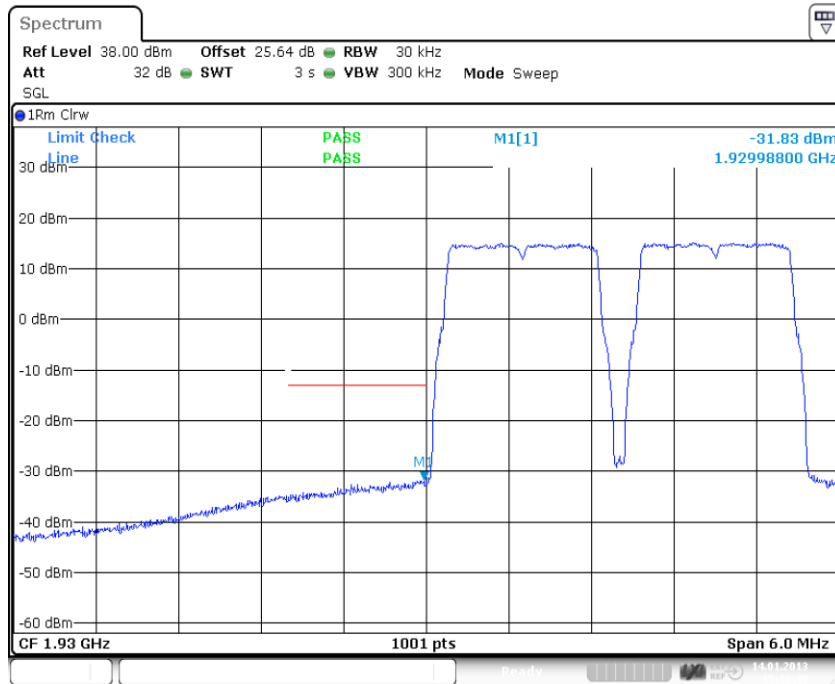

Date: 14.JAN.2013 15:10:49

plot 6.3.1.6-#1 Spurious Emissions at Antenna Terminals: §24.238, §2.1051; Test results; Downlink; LTE < 1MHz to band edge Lower Band Edge

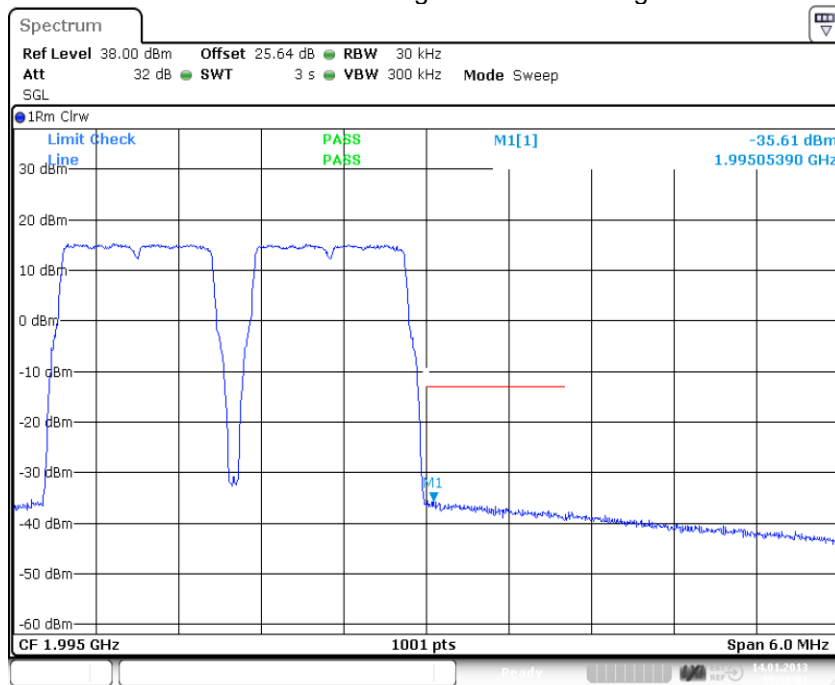

Date: 14.JAN.2013 15:11:01

plot 6.3.1.6-#2 Spurious Emissions at Antenna Terminals: §24.238, §2.1051; Test results; Downlink; LTE < 1MHz to band edge Upper Band Edge



6.3.1.7 Analog > 1MHz to band edge

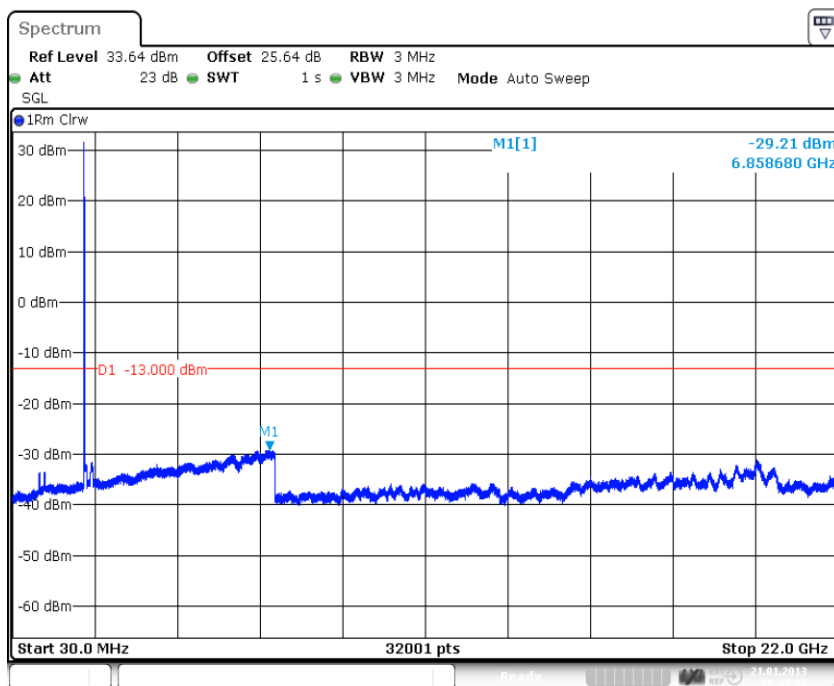

Date: 21.JAN.2013 15:45:10

plot 6.3.1.7-#1 Spurious Emissions at Antenna Terminals: §24.238, §2.1051; Test results; Downlink; Analog > 1MHz to band edge; Lower Band Edge

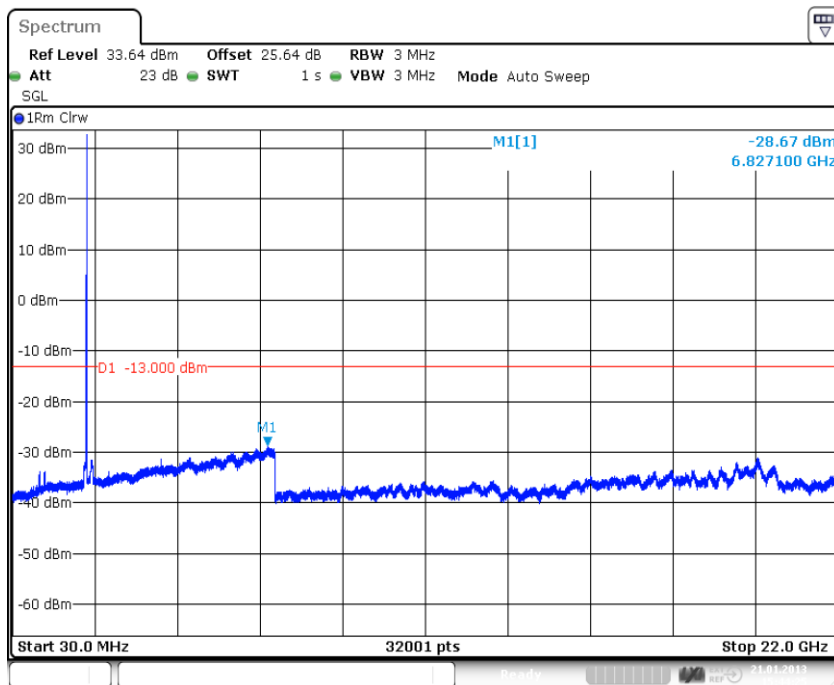

Date: 21.JAN.2013 15:44:25

plot 6.3.1.7-#2 Spurious Emissions at Antenna Terminals: §24.238, §2.1051; Test results; Downlink; Analog > 1MHz to band edge; Upper Band Edge



6.3.1.8 GSM > 1MHz to band edge

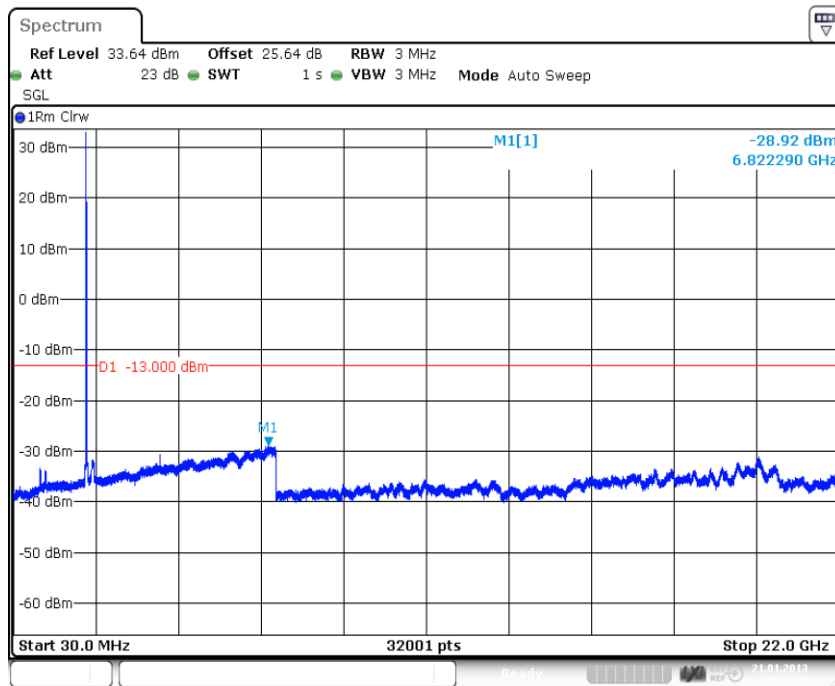

Date: 21.JAN.2013 15:36:28

plot 6.3.1.8-#1 Spurious Emissions at Antenna Terminals: §24.238, §2.1051; Test results; Downlink; GSM > 1MHz to band edge; Lower Band Edge

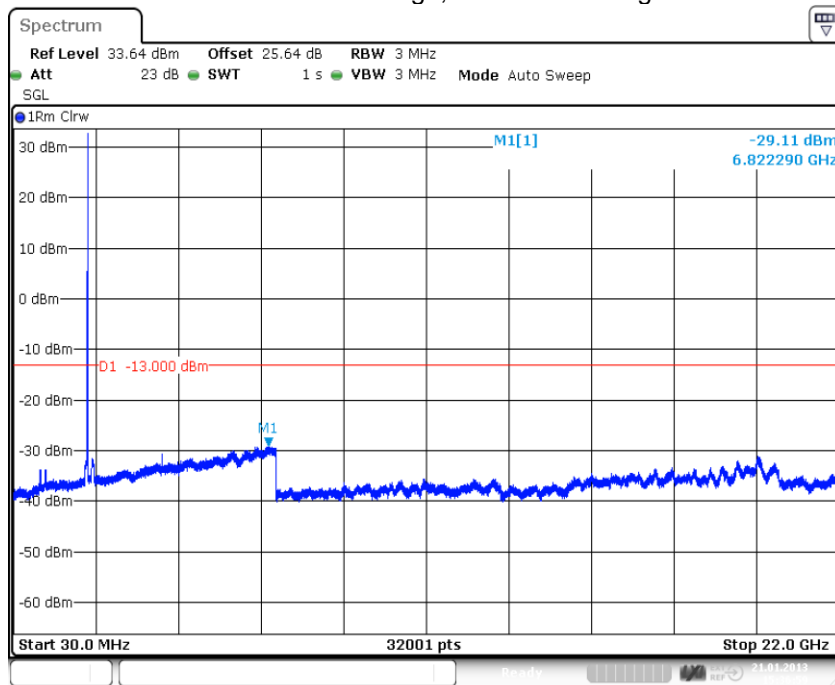

Date: 21.JAN.2013 15:36:59

plot 6.3.1.8-#2 Spurious Emissions at Antenna Terminals: §24.238, §2.1051; Test results; Downlink; GSM > 1MHz to band edge; Upper Band Edge



6.3.1.9 EDGE > 1MHz to band edge

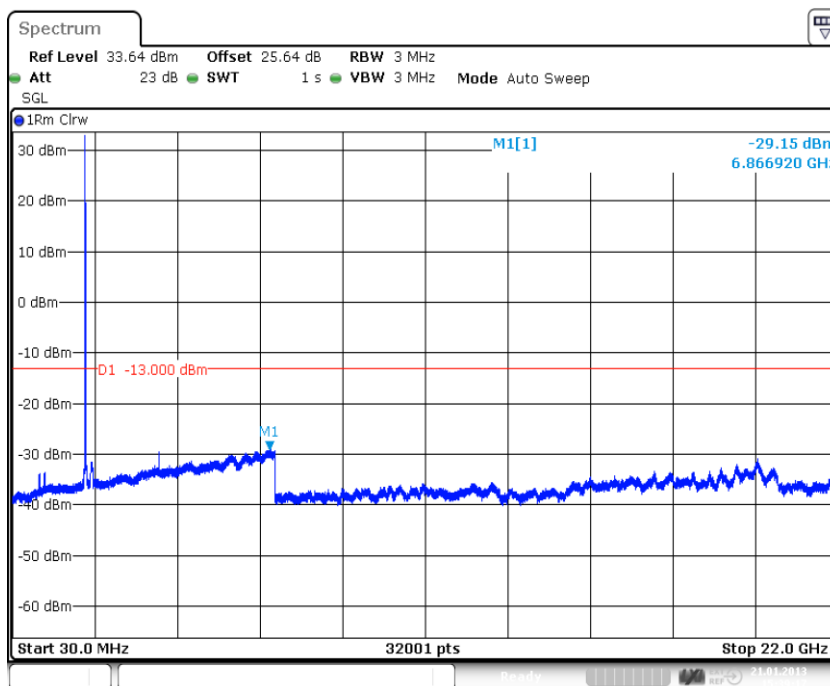

Date: 21.JAN.2013 15:39:17

plot 6.3.1.9-#1 Spurious Emissions at Antenna Terminals: §24.238, §2.1051; Test results; Downlink; EDGE > 1MHz to band edge; Lower Band Edge

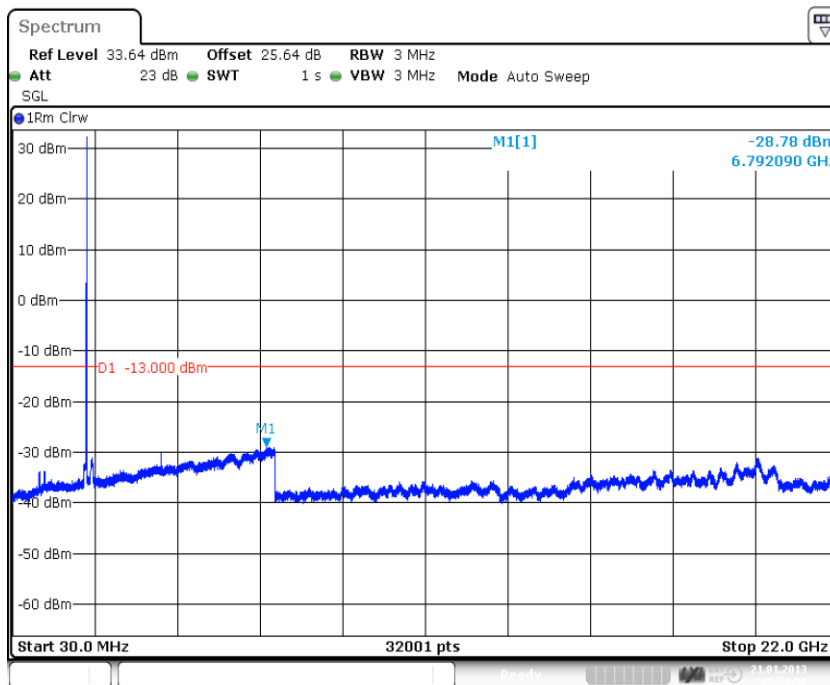

Date: 21.JAN.2013 15:39:52

plot 6.3.1.9-#2 Spurious Emissions at Antenna Terminals: §24.238, §2.1051; Test results; Downlink; EDGE > 1MHz to band edge; Upper Band Edge



6.3.1.10 CDMA > 1MHz to band edge

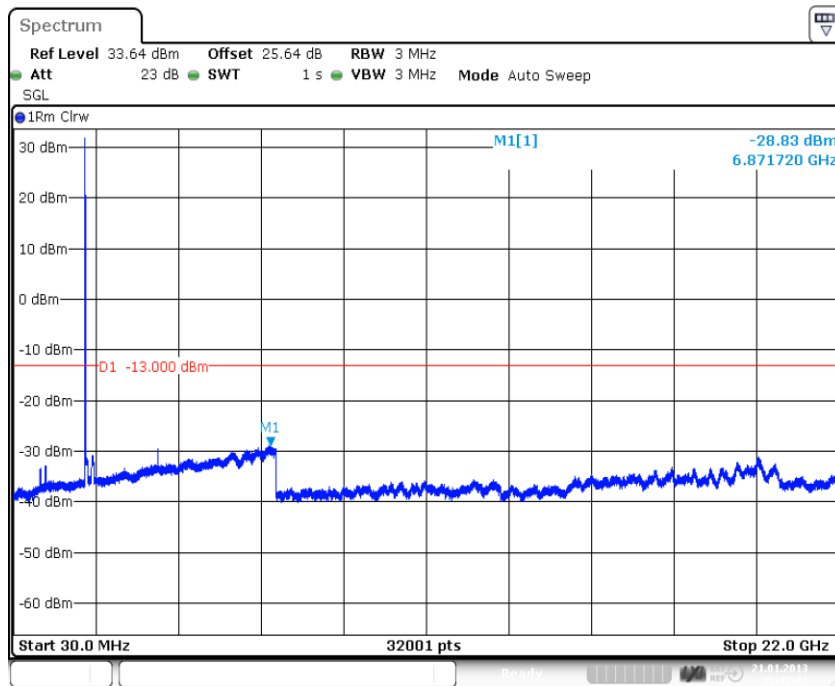

Date: 21.JAN.2013 15:47:33

plot 6.3.1.10-#1 Spurious Emissions at Antenna Terminals: §24.238, §2.1051; Test results; Downlink; CDMA > 1MHz to band edge; Lower Band Edge

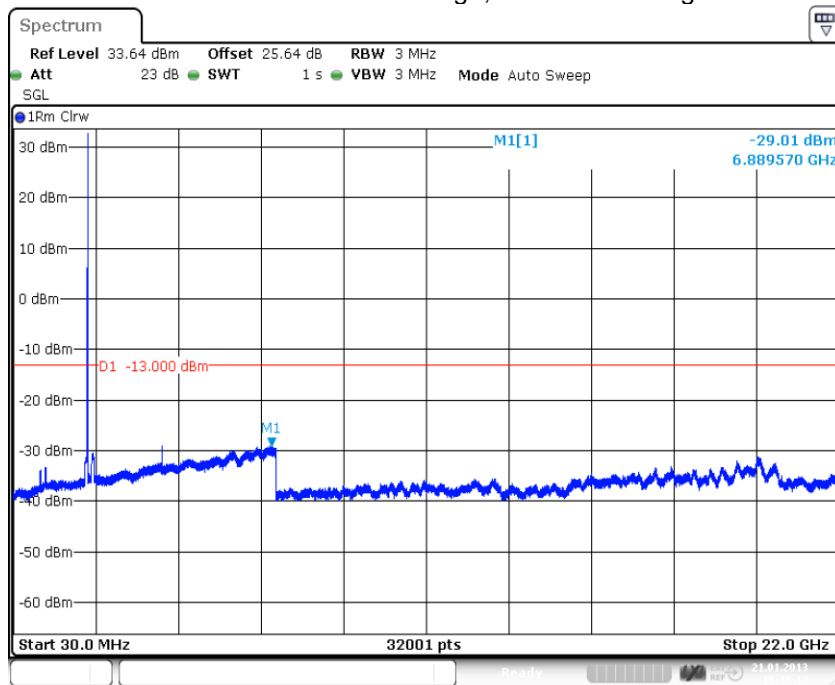

Date: 21.JAN.2013 15:48:12

plot 6.3.1.10-#2 Spurious Emissions at Antenna Terminals: §24.238, §2.1051; Test results; Downlink; CDMA > 1MHz to band edge; Upper Band Edge



6.3.1.11 W-CDMA > 1MHz to band edge

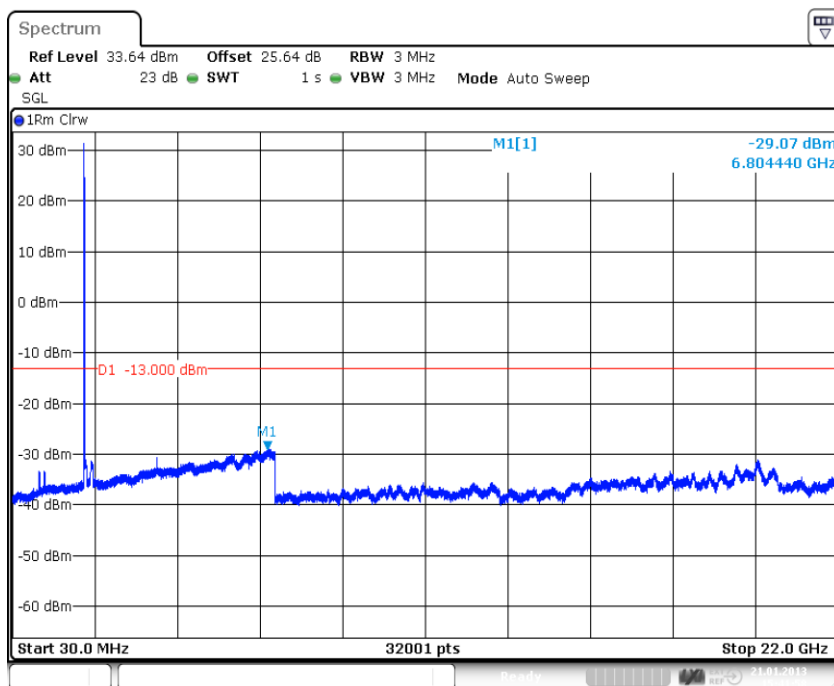

Date: 21.JAN.2013 15:41:58

plot 6.3.1.11-#1 Spurious Emissions at Antenna Terminals: §24.238, §2.1051; Test results; Downlink; W-CDMA > 1MHz to band edge; Lower Band Edge

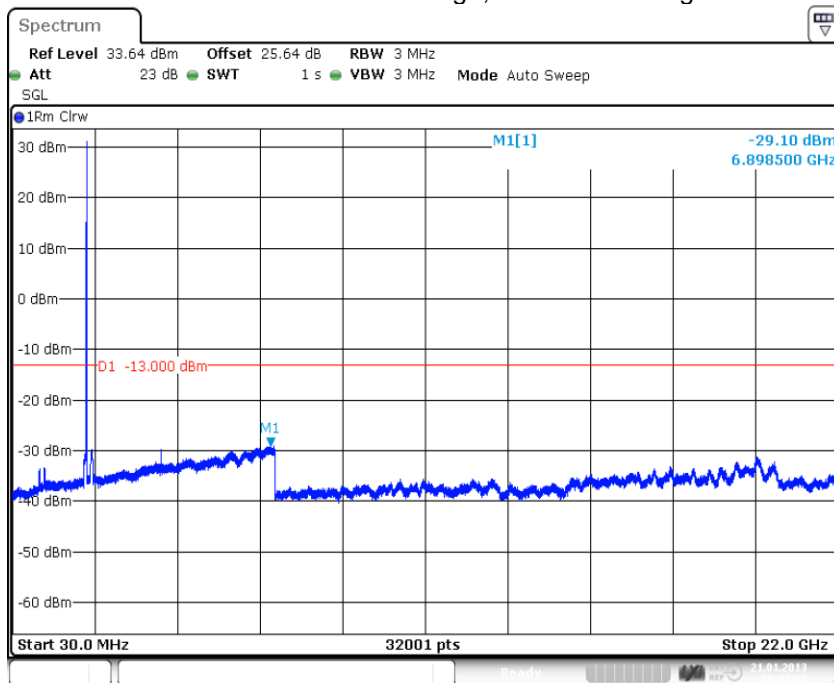

Date: 21.JAN.2013 15:42:31

plot 6.3.1.11-#2 Spurious Emissions at Antenna Terminals: §24.238, §2.1051; Test results; Downlink; W-CDMA > 1MHz to band edge; Upper Band Edge



6.3.1.12 LTE > 1MHz to band edge

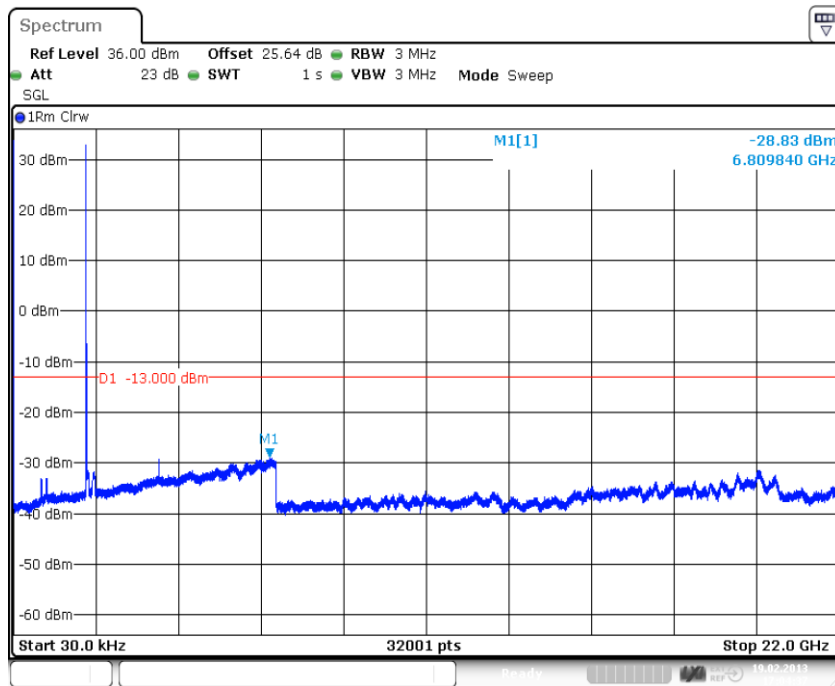

Date: 19.FEB.2013 17:04:37

plot 6.3.1.12-#1 Spurious Emissions at Antenna Terminals: §24.238, §2.1051; Test results; Downlink; LTE > 1MHz to band edge; Lower Band Edge

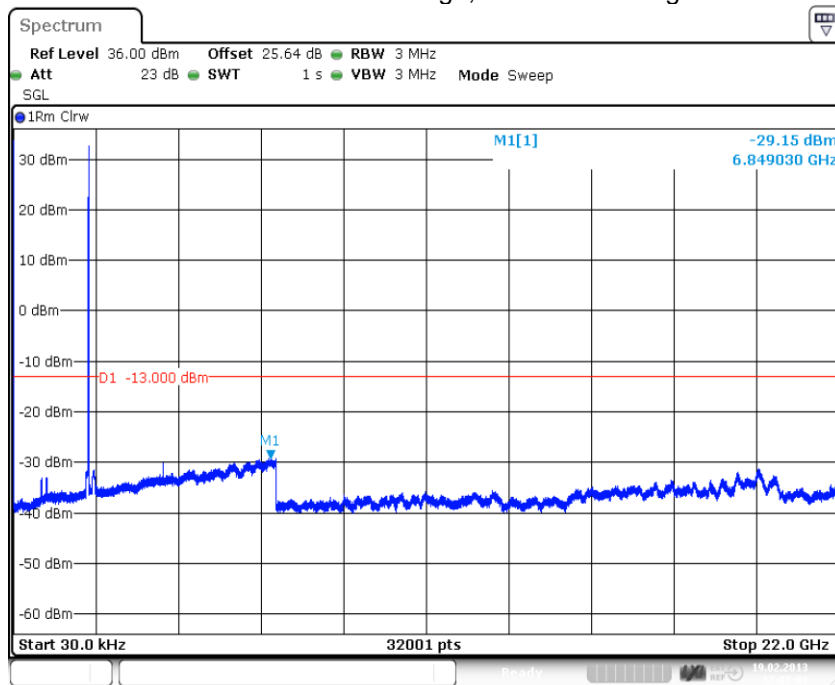

Date: 19.FEB.2013 17:05:02

plot 6.3.1.12-#2 Spurious Emissions at Antenna Terminals: §24.238, §2.1051; Test results; Downlink; LTE > 1MHz to band edge; Upper Band Edge

Test Report No.: 13-050

FCC ID: XS5-U7885L1719P

IC ID: 2237E-U7885L1719P



BUREAU
VERITAS

6.3.2 Uplink

n.a.

Note: The EUT does not transmit over the air in the uplink direction.

6.4 Summary test result

Test result	complies, according the plots above
Tested by:	M. Leinfelder
Date:	19.02.2013

7 Transmitter Output Power: IC RSS-133, RSS-GEN

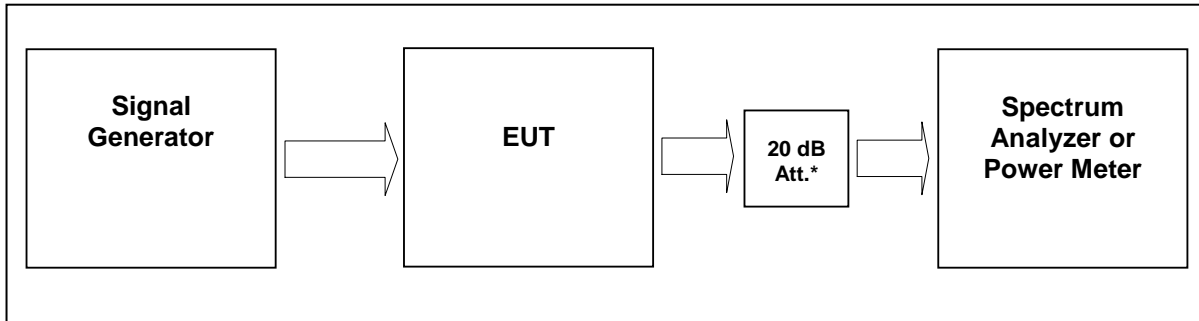

figure 6.4-#1 Test setup: Transmitter Output Power: IC RSS-133, RSS-GEN

Measurement uncertainty	± 0,38 dB
Test equipment used	9126, 9046, 7444; 7321; 7144; 7454;7453; 7341; 7449; 7368

7.1 Limit

Minimum standard:

IC RSS-133 clause 6.4

The average equivalent isotropically radiated power (e.i.r.p.) for transmitters shall not exceed the limits given in SRSP-510. Moreover, base station transmitters operating in the band 1930-1995 MHz shall not have output power exceeding 100 watts.

In addition, when the transmitter power is measured in terms of average value, the peak-to-average ratio of the power shall not exceed 13 dB..

7.2 Test method

IC RSS-133 clause 4.1

The transmitter power can be measured in peak or average value. If the transmitter power to be measured is in peak value, the transmitter power shall be measured over any interval of continuous transmission using an instrument calibrated in terms of a root-mean-square-equivalent voltage. The measurement results shall be properly adjusted for any instrument limitation, such as detector response times, sensitivity, limited resolution bandwidth capability when compared to the emission bandwidth, etc., so as to obtain the maximum transmit output power of the emission over the channel bandwidth.



7.3 Test results

Transmitter Output Power results see

clause4 RF Power Out: §24.232, §2.1046 sub clause 5.3 Test results

7.3.1 Downlink

Modulation	Measured at	Peak – to - average (dB)	Plot -
Analog	1962,5MHz	0.22	7.3.1.1 #1
GSM	1962,5 MHz	0.4	7.3.1.2 #1
GSM-EDGE	1962,5 MHz	3.47	7.3.1.3 #1
CDMA	1962,5 MHz	11.62	7.3.1.4 #1
WCDMA	1962,5 MHz	10.31	7.3.1.5 #1
LTE	1962,5 MHz	9.83	7.3.1.6 #1
Maximum peak to average = 11.62 dB			
Limit peak to average = 13 dB			

table 7.3.1-#1 Transmitter Output Power: IC RSS-133, RSS-GEN Test results Downlink Peak - to – average



7.3.1.1 Analog

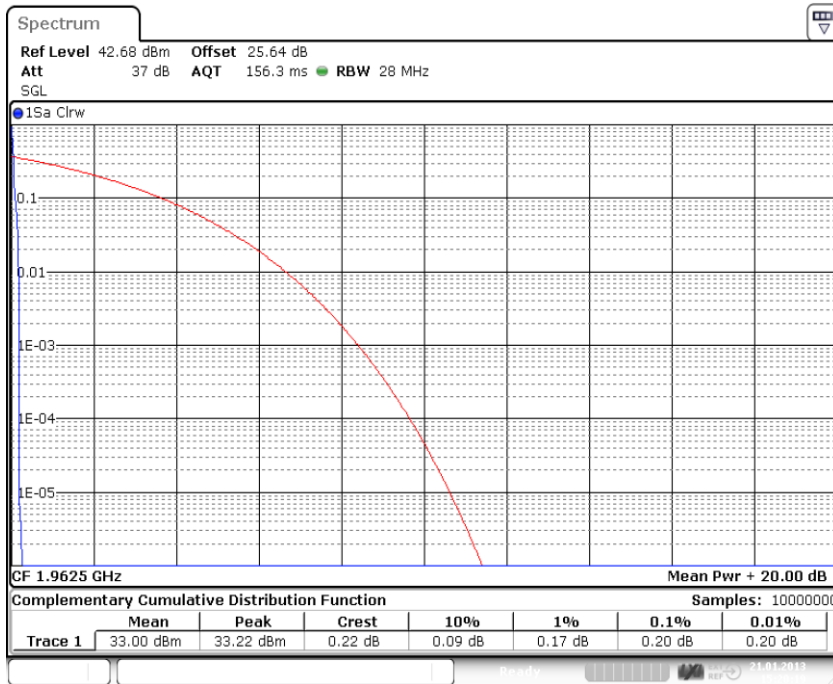

Date: 21.JAN.2013 15:20:19

plot 7.3.1.1-#1 Transmitter Output Power: IC RSS-133, RSS-GEN; Test results; Downlink; Analog Middle Peak – to - average

7.3.1.2 GSM

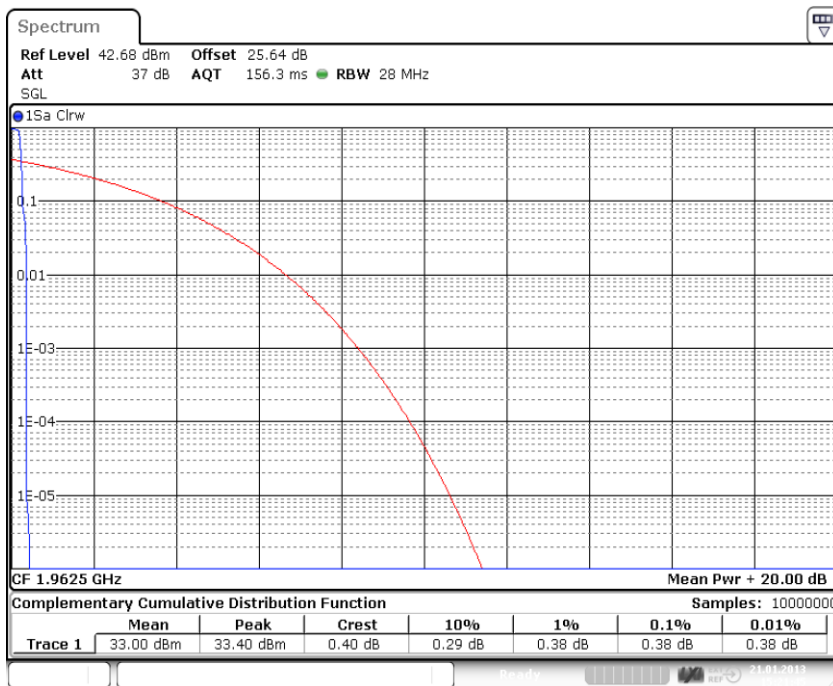

Date: 21.JAN.2013 15:21:45

plot 7.3.1.2-#1 Transmitter Output Power: IC RSS-133, RSS-GEN; Test results; Downlink; GSM Middle Peak – to - average



7.3.1.3 EDGE

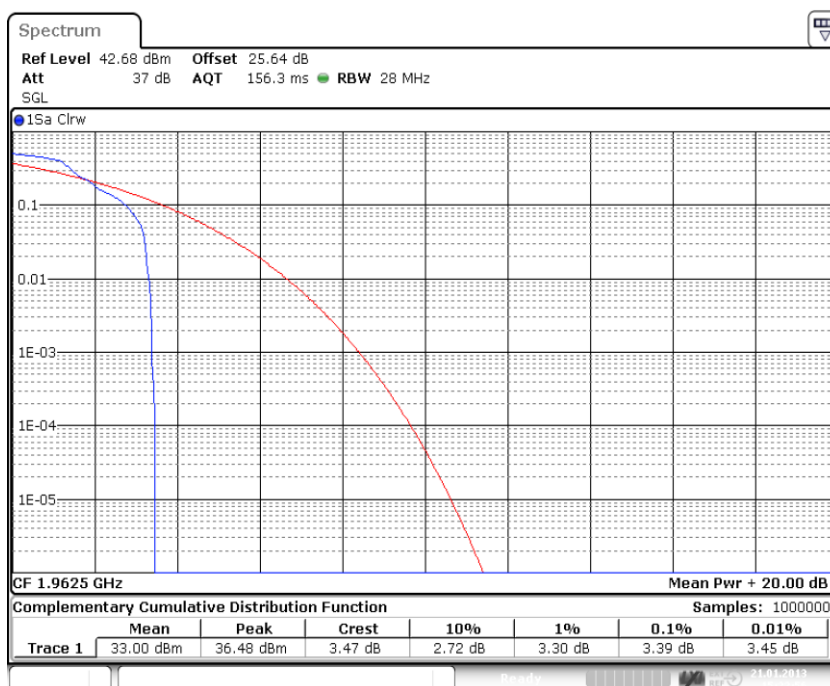

Date: 21.JAN.2013 15:22:56

plot 7.3.1.3-#1 Transmitter Output Power: IC RSS-133, RSS-GEN; Test results; Downlink; EDGE Middle Peak – to - average

7.3.1.4 CDMA

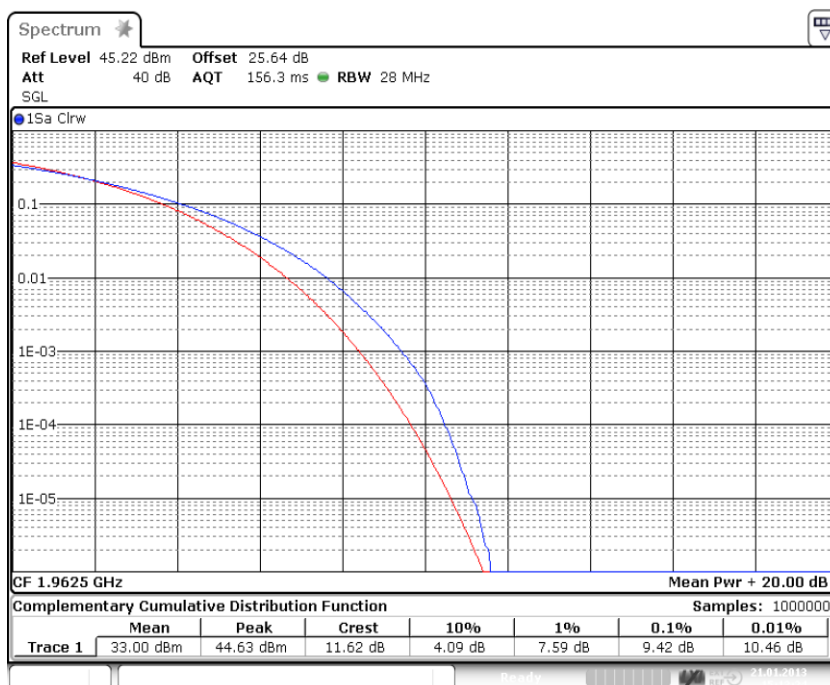

Date: 21.JAN.2013 15:13:24

plot 7.3.1.4-#1 Transmitter Output Power: IC RSS-133, RSS-GEN; Test results; Downlink; CDMA Middle Peak – to - average



7.3.1.5 W-CDMA

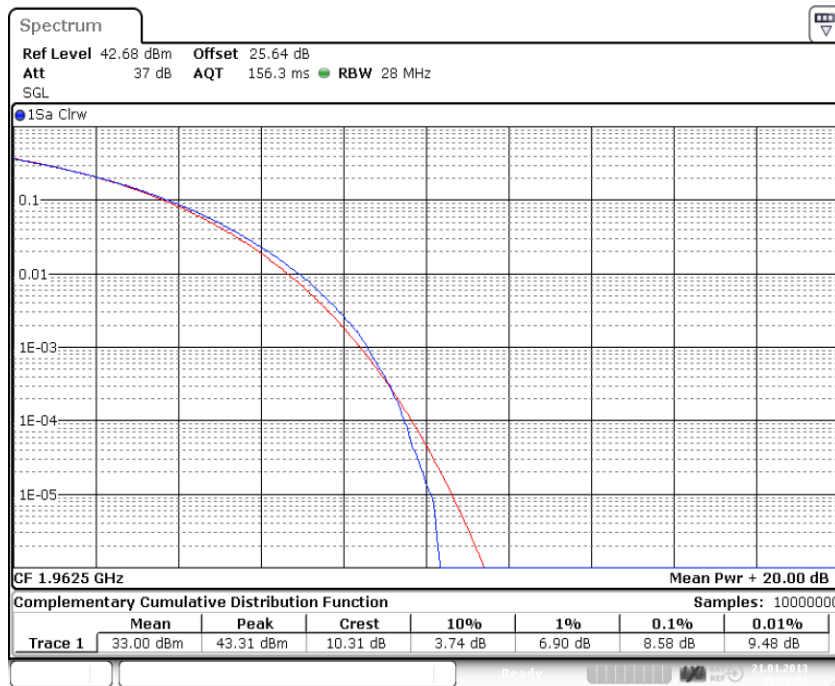

Date: 21.JAN.2013 15:18:01

plot 7.3.1.5-#1 Transmitter Output Power: IC RSS-133, RSS-GEN; Test results; Downlink; W-CDMA Middle Peak – to – average

7.3.1.6 LTE

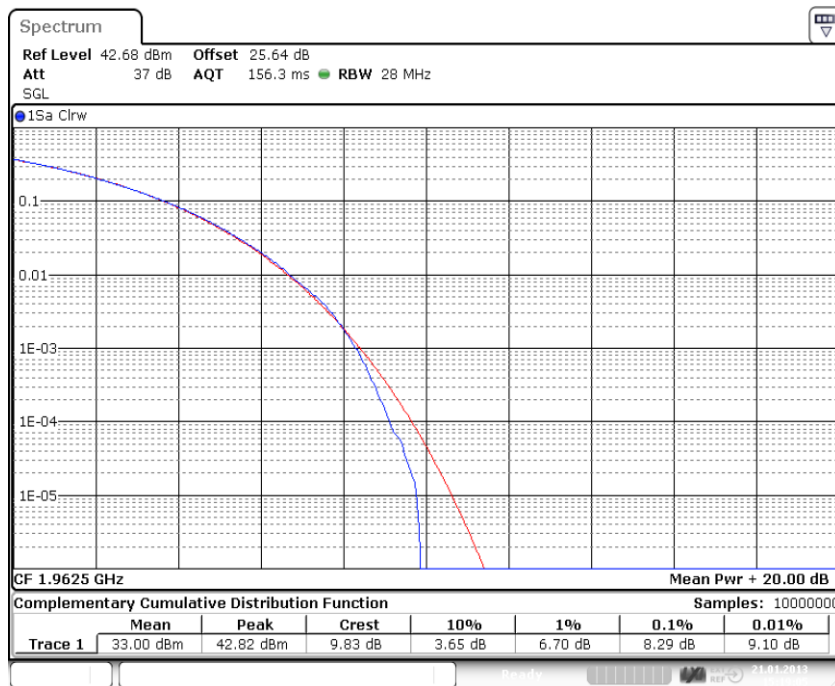

Date: 21.JAN.2013 15:19:05

plot 7.3.1.6-#1 Transmitter Output Power: IC RSS-133, RSS-GEN; Test results; Downlink; LTE Middle Peak – to - average

Test Report No.: 13-050

FCC ID: XS5-U7885L1719P

IC ID: 2237E-U7885L1719P



BUREAU
VERITAS

7.3.2 Uplink

n.a.

Note: The EUT does not transmit over the air in the uplink direction.

7.4 Summary test result

Test result	complies, according the plots above
Tested by:	M. Leinfelder
Date:	21.01.2013



8 Transmitter Unwanted Emissions: IC RSS-133

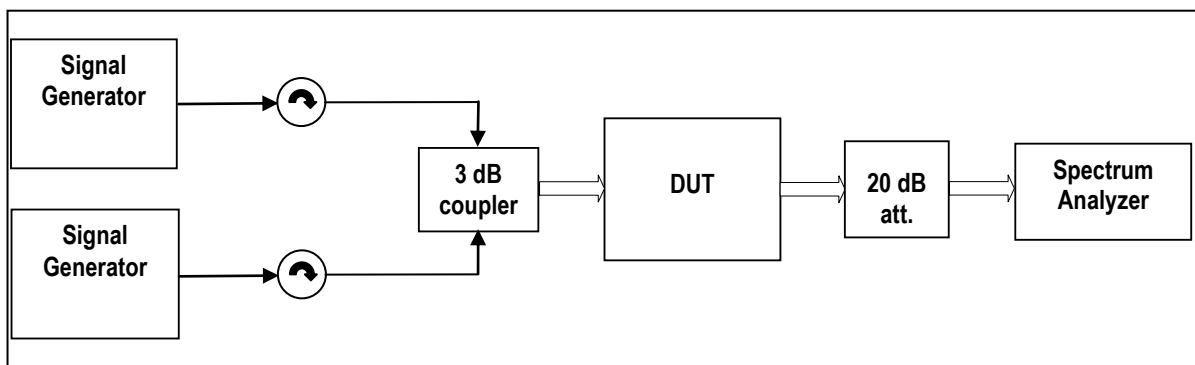

figure 8-#1 Test setup: Transmitter Unwanted Emissions: IC RSS-133

Measurement uncertainty	± 0,54 dB ± 1,2 dB ± 1,5 dB	9 kHz to 3 GHz 3 GHz to 7 GHz 7 GHz to 26 GHz
Test equipment used	9126, 9046, 8849; 7444; 7443; 7321; 7326; 7144; 7454; 7453; 7341; 7449; 7368	

8.1 Limit

IC RSS-133 clause 6.5.1 Out-of-Block Emissions (Mobile and Base Stations)
Subsection (i) chosen.

(a) Mobile stations shall comply with subsection (i) below. Base stations shall comply with either subsection (i) or subsection (ii).

(i) In the first 1.0 MHz bands immediately outside and adjacent to the equipment's operating frequency block, the emission power per any 1% of the emission bandwidth shall be attenuated below the transmitter output power P (in watts) by at least $43 + 10 \log_{10}(P)$, dB. Test method The emission limits shall be measured with the carrier frequency set at both the highest settable frequency and lowest settable frequency permitted by the design of the equipment.

(b) After the first 1.0 MHz (for equipment that complies with (a)(i) of this subsection) or 1.5 MHz (for equipment that complies with (a)(ii) of this subsection), the emission power in any 1 MHz bandwidth shall be attenuated below the transmitter output power P (in watts) by at least $43 + 10 \log_{10}(P)$, dB. (Note: If the test result using 1% of the emission bandwidth is used, power integration over 1.0 MHz is required; alternatively, the spectrum analyzer resolution and video bandwidths can be increased to 1.0 MHz for this measurement).

IC RSS-133 clause 6.5.2 Out-of-Sub-band Emissions

Outside the sub-bands 1850-1915 MHz and 1930-1995 MHz, the attenuation shall be equal to or greater than the out-of-block emission limits in Section 6.5.1.

8.2 Test method

IC RSS-133 clause 4.2

The emission limits shall be measured with the carrier frequency set at both the highest settable frequency and the lowest settable frequency permitted by the design of the equipment.

8.3 Test results

see6 subclause Spurious Emissions at Antenna Terminals: §24.238, §2.1051

for 6.5.1 (a)(i) see table 7.3-#1

for 6.5.1 Out-of-Block Emissions (a)(ii) and 6.5.2 Out-of-Sub-band Emissions see table 7.3-#2

Test Report No.: 13-050

FCC ID: XS5-U7885L1719P

IC ID: 2237E-U7885L1719P



BUREAU
VERITAS

9 Receiver Spurious Emissions: IC RSS-133

9.1 Limit

IC RSS-133 clause 6.6

Receiver spurious emissions shall comply with the limits specified in RSS-Gen.

Comment:

Receiver Spurious Emissions are not measured, since the Repeater has only one antenna port to transmit and receive at the same time (bi-directional amplifier)

The worst case for emission considerations is when the repeater is transmitting.

For transmitter unwanted emission test results see 8 Transmitter Unwanted Emissions: IC RSS-133

Test Report No.: 13-050

FCC ID: XS5-U7885L1719P

IC ID: 2237E-U7885L1719P



**BUREAU
VERITAS**

10 Radiated Spurious Emissions: §24.238, §2.1053, RSS-133



picture 8.1: label



picture 8.2: Test setup: Field Strength Emission in the SAC

Test Report No.: 13-050

FCC ID: XS5-U7885L1719P

IC ID: 2237E-U7885L1719P



BUREAU VERITAS

This clause specifies requirements for the measurement of radiated emission.

Frequency range	Distance: EUT <-> antenna / location	Limit	Test method
30 MHz - 1 GHz	3 metres / SAC	FCC 47 CFR Part 24.238 IC RSS-133 sec. 6.5	TIA/EIA-603-C:2004
1 GHz – 22 GHz	3 metres / SAC	FCC 47 CFR Part 24.238 IC RSS-133 sec. 6.5	

Test equipment used:

Designation	Type	Manufacturer	Invent.-no.	Cal.-date	due Cal.- date	used
EMI test receiver	ESI40	Rohde & Schwarz	E1687	19.12.2012	19.12.2013	X
Antenna	CBL 6111	Chase	K1024	29.03.2012	29.03.2013	X
RF Cable	RG214	Frankonia	K1121 SET	20.02.2013	20.02.2014	X
Antenna	HL 025	R&S	K809	16.11.2012	16.11.2013	X
Preamplifier	AFS4-00102000	Miteq	K838	05.06.2012	05.06.2013	X
RF Cable	Sucoflex 100	Suhner	K1742	23.05.2012	23.05.2013	X

The REMI version 2.135 has been used for max search.

Test set-up:

Test location: SAC
Both, the Fully Anechoic Chamber (FAC) and the Semi Anechoic Chamber (SAC) fulfil the requirements of ANSI C63.4 and CISPR 16-1-4 with regards to NSA and SVSWR.

Test Voltage: 115V / 60 Hz
Type of EUT: Wall mounted

Measurement uncertainty:

Measurement uncertainty expanded (95% or K=2)	± 4,7 dB for ANSI C63.4 measurement ± 0,5 dB for TIA-603 measurement
--	---

10.1 Limit §24.238

The rules in this section govern the spectral characteristics of emissions in the Broadband Personal Communications Service.

(a) *Out of band emissions.* The power of any emission outside of the authorized operating frequency ranges must be attenuated below the transmitting power (P) by a factor of at least $43 + 10 \log(P)$ dB.

(b) *Measurement procedure.* Compliance with these rules is based on the use of measurement instrumentation employing a resolution bandwidth of 1 MHz or greater. However, in the 1 MHz bands immediately outside and adjacent to the frequency block a resolution bandwidth of at least one percent of the emission bandwidth of the fundamental emission of the transmitter may be employed. A narrower resolution bandwidth is permitted in all cases to improve measurement accuracy provided the measured power is integrated over the full required measurement bandwidth (i.e. 1 MHz or 1 percent of emission bandwidth, as specified). The emission bandwidth is defined as the width of the signal between two points, one below the carrier center frequency and one above the carrier center frequency, outside of which all emissions are attenuated at least 26 dB below the transmitter power.

The limit is **-13dBm** (e.i.r.p).

10.2 Test method ANSI/TIA/EA-603-C

Measurement procedure. TIA-603-C

The antenna substitution method is used to determine the equivalent radiated power at spurious frequencies. The spurious emissions are measured at a distance of 3 meters. The EUT is then replaced with a reference substitution antenna with a known gain referenced to a dipole. This antenna is fed with a signal at the spurious frequency. The level of the signal is adjusted to repeat the previously measured level. The resulting eirp is the signal level fed to the reference antenna corrected for gain referenced to an isotropic dipole (see Figure 7.2).

From KDB (AMPLIFIER, BOOSTER, AND REPEATER REMINDER SHEET):

Radiated spurs (enclosure) – Use of CW signal (low, mid. and high freq.) is acceptable rather than all modulations.

The maximum RFI field strength was determined during the measurement by rotating the turntable (± 180 degrees) and varying the height of the receive antenna ($h = 1 \dots 4$ m) as like defined in ANSI C63.4. A measurement receiver has been used with a RBW 120 kHz up to 1 GHz and 1 MHz above 1 GHz. Steps with during pre measurement was half the RBW.

Both, the Fully Anechoic Chamber (FAC) and the Semi Anechoic Chamber (SAC) fulfil the requirements of ANSI C63.4 and CISPR 16-1-4 with regards to NSA and SVSWR.

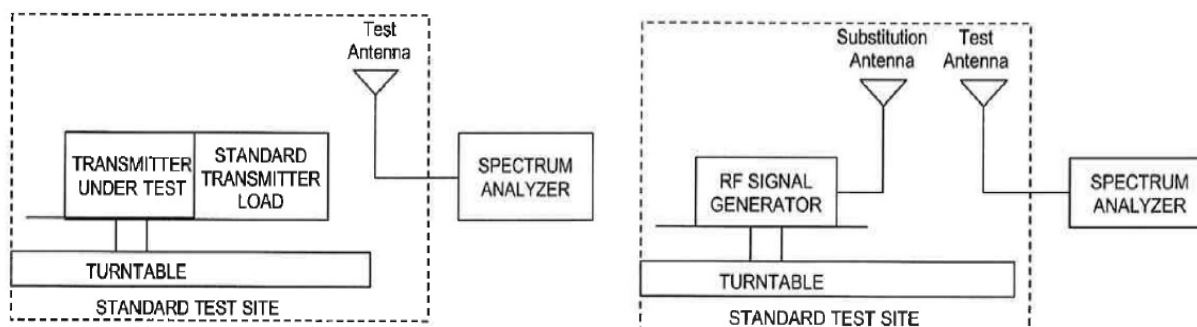

picture 8.3: Substitution method

Test Report No.: 13-050

FCC ID: XS5-U7885L1719P

IC ID: 2237E-U7885L1719P



BUREAU
VERITAS

10.3 Climatic values in the lab

Temperature: 20°
Relative Humidity: 45%
Air-pressure: 1009hPa

10.4 Receiver Settings

	up to 1 GHz	above 1 GHz
Measurement bandwidth	120 kHz	1 MHz
Step width	60 kHz	500 kHz
Dwell time	20ms	
Detector	Peak (max hold over 360°)	Peak (max hold over 360°)

Test Report No.: 13-050

FCC ID: XS5-U7885L1719P

IC ID: 2237E-U7885L1719P



**BUREAU
VERITAS**

10.5 Test results

10.5.1 30 MHz to 1 GHz Downlink (Bottom – Middle – Top)

Bottom 1930 MHz; Middle 1962.5 MHz; Top 1995 MHz

Horizontal / Vertikal

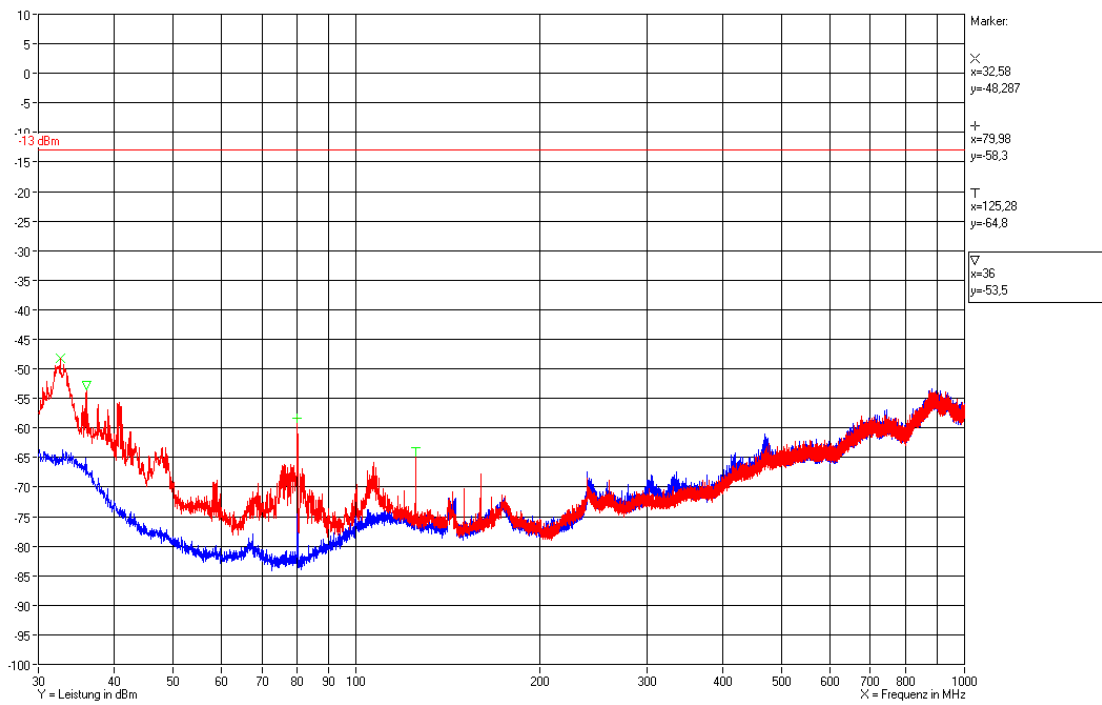



10.5.2 30 MHz to 1 GHz Downlink (Middle of all paths)

Horizontal / Vertikal

F1: 751.5 MHz; F2: 737 MHz; F3: 863.75 MHz; F4: 1962.5 MHz; F5: 2132.5 MHz

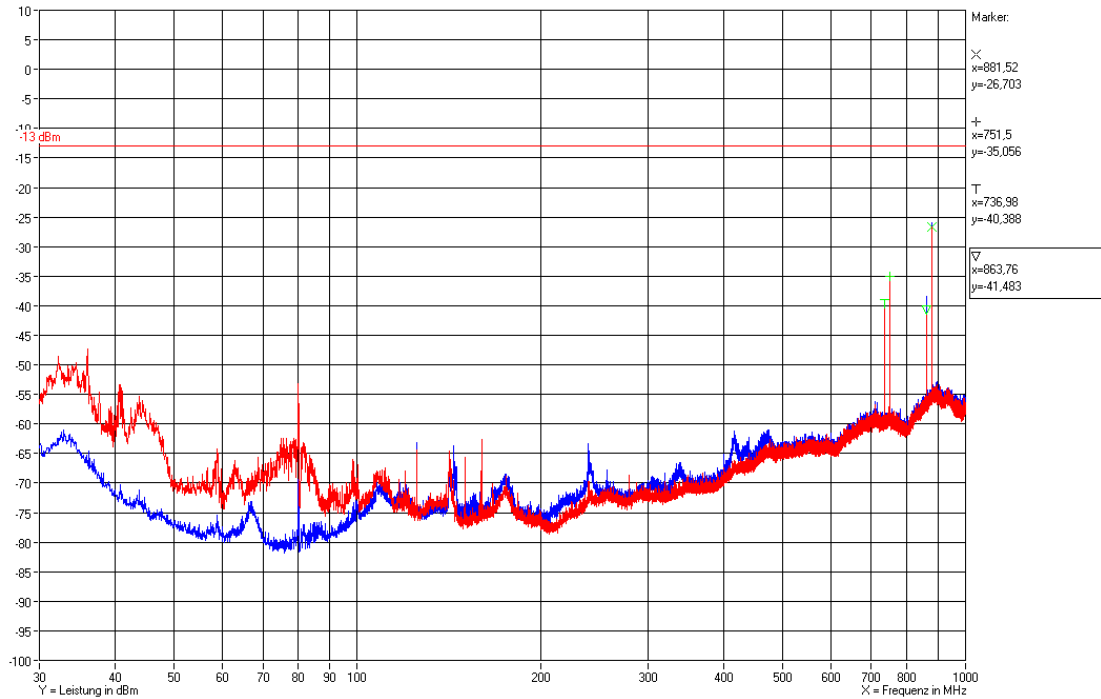

Test Report No.: 13-050

FCC ID: XS5-U7885L1719P

IC ID: 2237E-U7885L1719P



**BUREAU
VERITAS**

10.5.3 1 – 22 GHz Downlink (Bottom – Middle – Top)

Bottom 1930 MHz; Middle 1962.5 MHz; Top 1995 MHz

Horizontal / Vertikal

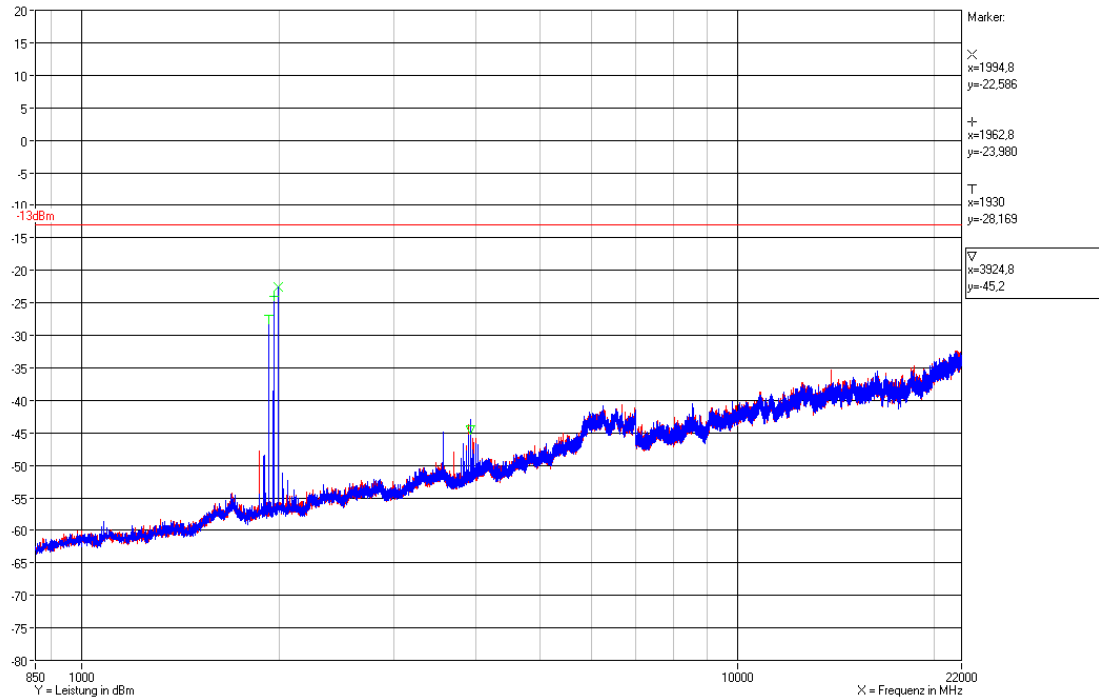

Test Report No.: 13-050

FCC ID: XS5-U7885L1719P

IC ID: 2237E-U7885L1719P



**BUREAU
VERITAS**

10.5.4 1 – 22 GHz Downlink (Middle of all paths)

Horizontal / Vertikal

F1: 751.5 MHz; F2: 737 MHz; F3: 863.75 MHz; F4: 1962.5 MHz; F5: 2132.5 MHz

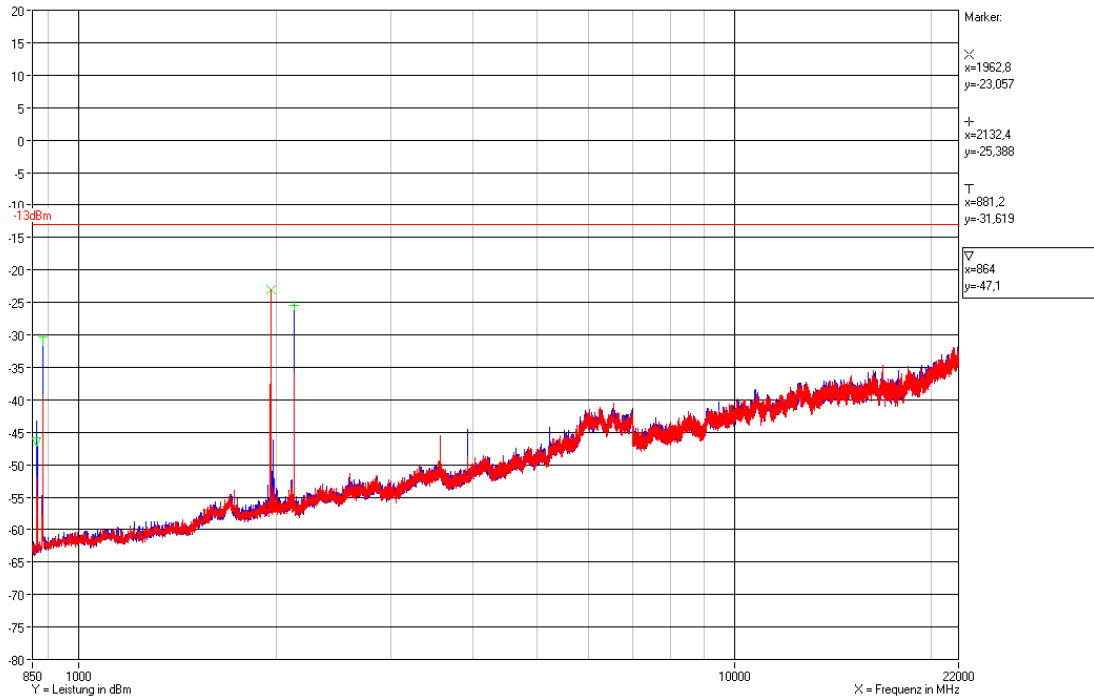

Zahlmann; 08.02.13

Test Report No.: 13-050

FCC ID: XS5-U7885L1719P

IC ID: 2237E-U7885L1719P



**BUREAU
VERITAS**

11 History

Revision	Modification	Date	Name
01.00	Initial report	27.02.2013	Zahlmann
02.00	Delete the system diagram of the EUT on page 8	25.06.2013	Zahlmann

******* End of test report *******