

Test Site:
FCC Test Site No.:
IC OATS No.:

96997
IC3475A-1



**BUREAU
VERITAS**

ECL-EMC Test Report No.: 13-048

Equipment under test: ION-U L 7/8/85/17P/19P Vac 800MHz Path
FCC ID: XS5-U7885L1719P
IC ID: 2237E-U7885L1719P
Type of test: **FCC 47 CFR Part 90 Subpart S:2013**
Private Land Mobile Repeater
RSS-Gen:2010, RSS-131:2005
Zone Enhancers for the Land Mobile Service

Measurement Procedures: 47 CFR Parts 2:2013 (*Frequency Allocations and Radio Treaty Matters; General Rules and Regulations*), Part 90:2013 (Private Land Mobile), ANSI/TIA-603-C (2004), *Land Mobile FM or PM Communications Equipment Measurement and Performance Standards*
IC-RSS-GEN:2010 General Requirements and Information for the Certification of Radiocommunication Equipment

Test result: **Passed**

Date of issue:	25.06.13	Signature:	
Issue-No.:	02	Author:	
Date of delivery:	08.02.13	Checked:	
Test dates:	14.01. – 08.02.13		
Pages:	53		

Test Report No.: 13-048

FCC ID: XS5-U7885L1719P

IC ID: 2237E-U7885L1719P



BUREAU
VERITAS

Manufacturer: ANDREW Wireless Systems GmbH
Industriering 10

D-86675 Buchdorf

Tel.: +49 (0)9099 69 0

Fax: +49 (0)9099 69 140

Test house: Bureau Veritas Consumer Products Services
Germany GmbH
European Compliance Laboratory (ECL)

Thurn-und-Taxis-Straße 18

D-90411 Nürnberg

Tel.: +49 40 74041 0

Fax: +49 40 74041-2755

General:

The purpose of this report is to show compliance to the FCC regulations for licensed devices operating under section 90 of the Code of Federal Regulations title 47.

This report informs about the results of the RF tests, it only refers to the equipment under test. No part of this report may be reproduced in any form, without written permission.



Table of contents

1	TEST RESULTS SUMMARY	6
2	EQUIPMENT UNDER TEST (E.U.T.)	7
2.1	DESCRIPTION	7
2.1.1	DOWNLINK	7
2.1.2	UPLINK	7
2.1.3	DESCRIPTION OF EUT	7
2.1.4	BLOCK DIAGRAM OF MEASUREMENT REFERENCE POINTS	8
2.1.5	DOWNLINK SYSTEM GAIN AND OUTPUT POWER	8
3	TEST SITE (ANDREW BUCHDORF)	9
3.1	TEST ENVIRONMENT	9
3.2	TEST EQUIPMENT	9
3.3	INPUT AND OUTPUT LOSSES	10
3.4	MEASUREMENT UNCERTAINTY	10
4	TEST SITE (BUREAU VERITAS CONSUMER PRODUCT SERVICES)	11
5	RF POWER OUT: §90.635, §2.1046	12
5.1	LIMIT	12
5.2	TEST METHOD	12
5.3	TEST RESULTS	13
5.3.1	DOWNLINK	14
5.3.1.1	Analog	15
5.3.1.2	GSM	15
5.3.1.3	EDGE	16
5.3.1.4	CDMA	16
5.3.2	UPLINK	17
5.4	SUMMARY TEST RESULT	17
6	OCCUPIED BANDWIDTH: §90.210, §2.1049	18
6.1	LIMIT	18
6.2	TEST METHOD	18
6.3	TEST RESULTS	18
6.3.1	DOWNLINK	18
6.3.1.1	Analog	19
6.3.1.2	GSM	20
6.3.1.3	EDGE	21
6.3.1.4	CDMA	22
6.3.2	UPLINK	23
6.4	SUMMARY TEST RESULT	23
7	SPURIOUS EMISSIONS AT ANTENNA TERMINALS: §90.210, §2.1051	24
7.1	LIMIT	24



7.2	TEST METHOD	26
7.3	TEST RESULTS	26
7.3.1	DOWNLINK	26
7.3.1.1	Analog < 1MHz to band edge	27
7.3.1.2	GSM < 1MHz to band edge	28
7.3.1.3	EDGE < 1MHz to band edge	29
7.3.1.4	CDMA < 1MHz to band edge	30
7.3.1.5	Analog > 1MHz to band edge	31
7.3.1.6	GSM > 1MHz to band edge	32
7.3.1.7	EDGE > 1MHz to band edge	32
7.3.1.8	CDMA > 1MHz to band edge	33
7.3.2	UPLINK	33
7.4	SUMMARY TEST RESULT	33
8	AMPLIFIER GAIN AND BANDWIDTH: IC RSS-131	34
8.1	LIMIT	34
8.2	TEST METHOD	34
8.3	TEST RESULTS	34
8.3.1	DOWNLINK	34
8.3.2	UPLINK	35
8.4	SUMMARY TEST RESULT	35
9	OUTPUT POWER: IC RSS-131	36
9.1	LIMIT	36
9.2	TEST METHOD	36
9.3	TEST RESULTS	37
9.3.1	DOWNLINK	37
9.3.2	UPLINK	37
9.4	SUMMARY TEST RESULT	37
10	NON-LINEARITY: IC RSS-131	38
10.1	LIMIT	38
10.2	TEST METHOD	38
10.3	TEST RESULTS	39
10.3.1	DOWNLINK	39
10.3.2	UPLINK	39
10.4	SUMMARY TEST RESULT	39
11	SPURIOUS EMISSIONS: RSS-131	40
11.1	LIMIT	40
11.2	TEST METHOD	40
11.3	TEST RESULTS	40
11.3.1	DOWNLINK	40
11.3.2	UPLINK	42
11.4	SUMMARY TEST RESULT	42

Test Report No.: 13-048

FCC ID: XS5-U7885L1719P

IC ID: 2237E-U7885L1719P



**BUREAU
VERITAS**

12	RADIATED SPURIOUS EMISSIONS AT THE ECL (BUREAU VERITAS): §90.210, §90.691, §2.1053, RSS GEN, RSS-131.....	43
12.1	METHOD OF MEASUREMENT.....	45
12.2	LIMIT.....	46
12.3	RECEIVER SETTINGS.....	48
12.4	CLIMATIC VALUES IN THE LAB.....	48
12.5	TEST RESULTS.....	49
12.5.1.1	30 MHz to 1 GHz Downlink (<u>B</u> ottom – <u>M</u> iddle – <u>T</u> op)	49
12.5.1.2	30 MHz to 1 GHz Downlink (middle of all path).....	50
12.5.1.3	1 GHz to 22 GHz Downlink (<u>B</u> ottom – <u>M</u> iddle – <u>T</u> op).....	51
12.5.1.4	1 GHz to 22 GHz Downlink (<u>B</u> ottom – <u>M</u> iddle – <u>T</u> op).....	52
13	HISTORY.....	53



1 Test Results Summary

Name of Test	FCC Para. No.	FCC Method	FCC Spec.	Result
RF Power Output	90.635	2.1046	1000 Watts	Complies
Occupied Bandwidth	90.210	2.1049	Input/Output	Complies
Spurious Emissions at Antenna Terminals	90.210	2.1051	-13dBm	Complies
Radiated Spurious emission	90.543	2.1053	-13dBm	Complies
Frequency Stability	90.213	2.1055	1 ppm	NA

Name of Test	IC Para. No.	IC Method	Result
RF Power Output	RSS-131	RSS-GEN 4.8	Complies
Occupied Bandwidth	RSS-131	RSS-GEN 4.6.1	Complies
Spurious Emissions at Antenna Terminals	RSS-131	RSS-GEN 4.9	Complies
Field Strength of Spurious Emissions	RSS-131 6.4	RSS-GEN 4.9	Complies
Frequency Stability	RSS-131	RSS-GEN 4.7	NA

Frequency stability is given by: The system gets an electrical analog signal from the BSS which is converted into an analog optical signal, transmitted by the optical links and then reconverted in the Remote Unit into an analog electrical signal. During this process happens no frequency change/modification, so input and output have same frequency what can be seen under capture "Occupied Bandwidth".



2 Equipment under test (E.U.T.)

2.1 Description

Kind of equipment	ION-U L 7/8/85/17P/19P Vac
Andrew Ident. Number	Id. No. 7669582-00
Serial no.(SN)	11
Revision	00
Software version and ID	n. a.
Type of modulation and Designator	F3E (Voice) <input checked="" type="checkbox"/> GSM (GXW) <input checked="" type="checkbox"/> GSM EDGE (G7W) <input checked="" type="checkbox"/> CDMA (F9W) <input checked="" type="checkbox"/>
Frequency Translation	F1-F1 <input checked="" type="checkbox"/> F1-F2 <input type="checkbox"/> N/A <input type="checkbox"/>
Band Selection	Software <input type="checkbox"/> Duplexer <input checked="" type="checkbox"/> Full band <input type="checkbox"/>

2.1.1 Downlink

Pass band	Path 858.5 MHz – 869 MHz
Nominal 20dB bandwidth	43.32 MHz
Max. composite output power based on one carrier per path (rated)	29 dBm = 0.8 W
Gain	49 dB

2.1.2 Uplink

Pass band	n. a.
System Gain*	n. a.

Note: The EUT does not transmit over the air in the uplink direction.

2.1.3 Description of EUT

ION-U L 7/8/85/17P/19P Vac is a multi-band, multi-operator remote unit configuration used in conjunction with a master unit in the ION optical distribution system.

This system transports up to five frequency bands simultaneously (700 MHz, 800MHz, 850 MHz, 1900 MHz, 1700MHz), providing a cost-effective solution for distributing capacity from one or more base stations.

The ION-U L 7/8/85/17P/19P Vac Repeater consists of one 700 MHz, one 800 MHz, one 850 MHz, one 1900 MHz and one 1700 MHz (2100MHz in DL) path, with the intended use of simultaneous transmission. This Test Report describes only the approval of the 800 MHz path



2.1.4 Block diagram of measurement reference points

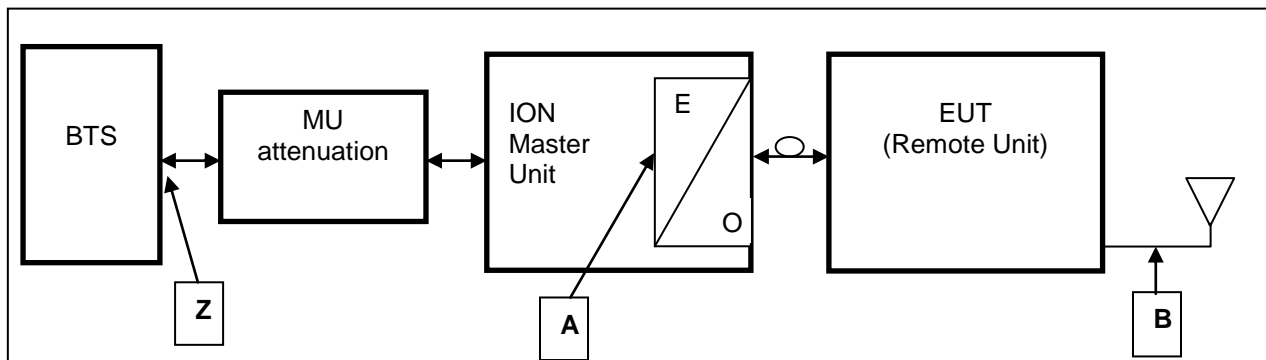

figure 2.1.4-#1 Block diagram of measurement reference points

Remote Unit is the EUT

O/E Optical / Electrical converter
SRMU Sub Rack Master Unit

Reference point A SRMU UL output, DL input
Reference point B Remote Unit DL output, UL input
Reference point Z BTS DL output, UL input

Downlink: Measure from reference point B to A

Since a signal generator does not supply a good output signal with +33 or +43dBm, for the downlink measurement the MU Attenuation is not used.

That means for downlink measurements the signal generator is connected to measurement point A at the master optical / electrical converter and the analyzer to the measurement point B at the RU.

2.1.5 Downlink System Gain and Output Power

System optimized for BTS power (fixed value) Z	MU Attenuation (manual leveling)	Maximum rated input power at the MU OTRX (fixed value) B	RU Gain (fixed value) B to A	Maximum rated output power at RU Antenna port (fixed value) A
+33 dBm	53 dB	-20 dBm	+49 dB	+29.0 dBm @ 1 carrier
System Gain Z to A	-4 dB			
+43 dBm	63 dB	-20 dBm	+49 dB	+29.0 dBm @ 1 carrier
System Gain Z to A	-14 dB			

table 2.1.5-#1 Equipment under test (E.U.T.) Description Downlink System Gain and Output Power



3 Test site (Andrew Buchdorf)

3.1 Test environment

All tests were performed under the following environmental conditions:

Condition	Minimum value	Maximum value
Barometric pressure	86 kPa	106 kPa
Temperature	15°C	30°C
Relative Humidity	20 %	75 %
Power supply range	±5% of rated voltages	
Test Voltage	230V AC 50Hz	

3.2 Test equipment

ANDREW Inv. No.	Test equipment	Type	Manufacturer	Serial No.	Calibration
9102	Network Analyzer	ZVB14	R&S	100118	08/13
9054	Spectrum Analyzer	FSV13	R&S	100859	12/13
9046	Signal Generator	SMBV100A	R&S	255090	06/13
8849	Signal Generator	SMU200A	R&S	101732	04/13
8671	Power Meter	E4418B	Agilent	GB39513094	06/13
8672	Power Sensor	E9300H	Agilent	US41090179	06/13
7306	Circulator	C25E-1FFF	AEROTEK	12580	CIU
7307	Circulator	C25E-1FFF	AEROTEK	12581	CIU
7408	RF-Cable	2,0m; N-N	Andrew	---	CIU
7409	RF-Cable	2,0m; N-N	Andrew	---	CIU
7410	RF-Cable	1,0m; N-N	Andrew	---	CIU
7411	RF-Cable	2,0m; N-N	Andrew	---	CIU
7373	RF-Cable	Multiflex141	Andrew	---	CIU
7374	RF-Cable	Multiflex141	Andrew	---	CIU
7437	RF-Cable	Multiflex141	Andrew	---	CIU
7438	RF-Cable	Multiflex141	Andrew	---	CIU
7439	RF-Cable	Multiflex141	Andrew	---	CIU
7443	RF-Cable	Multiflex141	Andrew	---	CIU
7444	RF-Cable	Multiflex141	Andrew	---	CIU
7445	RF-Cable	Multiflex141	Andrew	---	CIU
7446	RF-Cable	Multiflex141	Andrew	---	CIU
7447	RF-Cable	Multiflex141	Andrew	---	CIU
7448	RF-Cable	Multiflex141	Andrew	---	CIU
7449	RF-Cable	Multiflex141	Andrew	---	CIU
7450	RF-Cable	Multiflex141	Andrew	---	CIU
7440	RF-Cable	RG-223 0.8m	Andrew	---	CIU
7441	RF-Cable	RG-223 0.8m	Andrew	---	CIU
7453	RF-Cable	RG223 2m SMA.	Andrew	---	CIU
7454	RF-Cable	RG223 2m SMA.	Andrew	---	CIU
7455	RF-Cable	RG223 2m SMA.	Andrew	---	CIU
7144	Attenuator	2N-20dB	Inmet 64671	---	CIU
7341	Power Attenuator	768-20	Narda	---	CIU
7368	Matrix		COMMSCOPE	---	weekly

Test Report No.: 13-048

FCC ID: XS5-U7885L1719P

IC ID: 2237E-U7885L1719P



BUREAU
VERITAS

CIU = Calibrate in use

3.3 Input and output losses

All recorded power levels should be referenced to the input and output connectors of the repeater, unless explicitly stated otherwise.

The test equipment used in this test has to be calibrated, so that the functionality is also checked.

All cables, attenuators, splitter, isolator, circulator and combiner etc. must be measured before testing and used for compensation during testing.

3.4 Measurement uncertainty

The extended measurement uncertainty corresponds to the measurement results from the standard measurement uncertainty multiplied by the coverage factor $k=2$. The true value is located in the corresponding interval with a probability of 95 %.

Test Report No.: 13-048

FCC ID: XS5-U7885L1719P

IC ID: 2237E-U7885L1719P



4 Test site (Bureau Veritas Consumer Product Services)

FCC Test site: 96997
IC OATS: IC3475A-1

See relevant dates under section 8 of this test report.



5 RF Power Out: §90.635, §2.1046

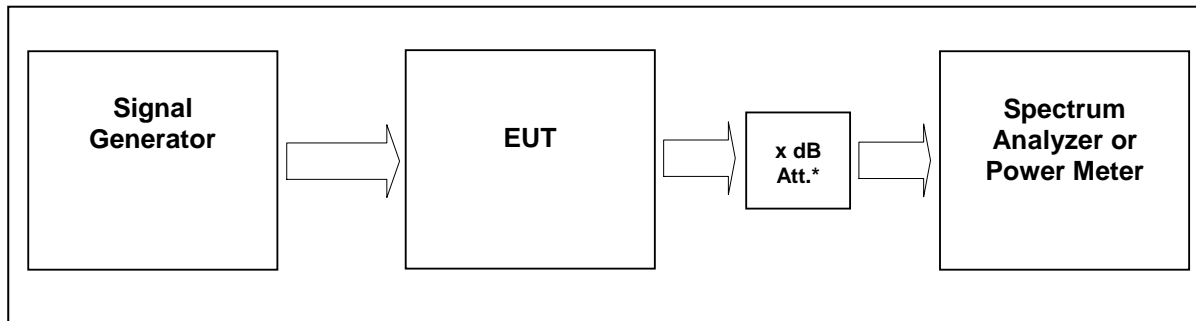

External Attenuator DL x dB = 20 dB
figure 5-#1 Test setup: RF Power Out: §90.635, §2.1046

Measurement uncertainty	± 0,38 dB
Test equipment used	9054, 9046, 7444; 7306; 7144; 7454;7453; 7341; 7449; 7368

5.1 Limit

Minimum standard:

§ 90.635 Limitations on power and antenna height.

(a) The effective radiated power and antenna height for base stations may not exceed 1 kilowatt (30 dBW) and 304 m. (1,000 ft.) above average terrain (AAT), respectively, or the equivalent thereof as determined from the Table. These are maximum values, and applicants will be required to justify power levels and antenna heights requested.

5.2 Test method

§ 2.1046 Measurements required: RF power output.

(a) For transmitters other than single sideband, independent sideband and controlled carrier radiotelephone, power output shall be measured at the RF output terminals when the transmitter is adjusted in accordance with the tune-up procedure to give the values of current and voltage on the circuit elements specified in § 2.1033(c)(8). The electrical characteristics of the radio frequency load attached to the output terminals when this test is made shall be stated.

(c) For measurements conducted pursuant to paragraphs (a) and (b) of this section, all calculations and methods used by the applicant for determining carrier power or peak envelope power, as appropriate, on the basis of measured power in the radio frequency load attached to the transmitter output terminals shall be shown. Under the test conditions specified, no components of the emission spectrum shall exceed the limits specified in the applicable rule parts as necessary for meeting occupied bandwidth or emission limitations

Test Report No.: 13-048

FCC ID: XS5-U7885L1719P

IC ID: 2237E-U7885L1719P



**BUREAU
VERITAS**

5.3 Test Results

Detector RMS.

Test signal Analog:

FM signal with 3.0 kHz deviation and 2.5 kHz rate and sine waveform.

Test signal GSM:

Signal waveform with GMSK modulation in all time slots according to 3GPP TS45.004

Test signal GSM EDGE:

Signal waveform with 8-PSK modulation in all time slots according to 3GPP TS45.004

Test signal CDMA

Signal waveform according to table 6.2-1 of standard specification 3GPP2 C.p0051-0 v1.0

16.February 2006 pilot, sync, paging, 37 traffics, which is equal to the table 6.5.2.1 of 3GPP2 C.S0010-C v2.0 24.February 2006.

According to ANSI C63.4 section 13.1 Table 5 for operating frequencies more then 10MHz: The test shall be performed at Bottom, Middle and Top frequencies.



5.3.1 Downlink

Modulation	Measured at		RBW VBW Span	RF Power [dBm]	RF Power [W]	Plot -
Analog	Middle	863.75 MHz	100kHz 300kHz 1,5MHz	29.0	0.8	5.3.1.1 #1
GSM	Middle	863.75 MHz	1MHz 3MHz 10MHz	29.0	0.8	5.3.1.2 #1
EDGE	Middle	863.75 MHz	1MHz 3MHz 10MHz	29.0	0.8	5.3.1.3 #1
CDMA	Middle	863.75 MHz	3MHz 10MHz 15MHz	29.0	0.8	5.3.1.4 #1
Maximum output power = 29.0 dBm = 0.8 W						
Limit Maximum output power = 60 dBm = 1000 W (erp)						

table 5.3.1-#1 RF Power Out: §90.635, §2.1046 Test Results Downlink

The max RF Power out is 29 dBm, so the maximum antenna gain (x) can be calculated as follow:

Limit = 1000W (erp) = 60 dBm

Info: 1000W (erp) = 1640W (eirp)

60 dBm > 29 dBm + x -----> x = 60 dBm – 29 dBm = 31 dBd

x dBi = 31 dBd + 2.15 = 33.15 dBi

=> The antenna that will use for the complete system have to have a gain lower than 33 dBi, relative to a dipol.

Modulation	Pin / dBm (Ref. point A)
Analog	-21.3
GSM	-20.9
EDGE	-21.0
CDMA	-21.3

table 5.3.1-#2 RF Power Out: §90.635, §2.1046 Test Results; Downlink; Input power



5.3.1.1 Analog

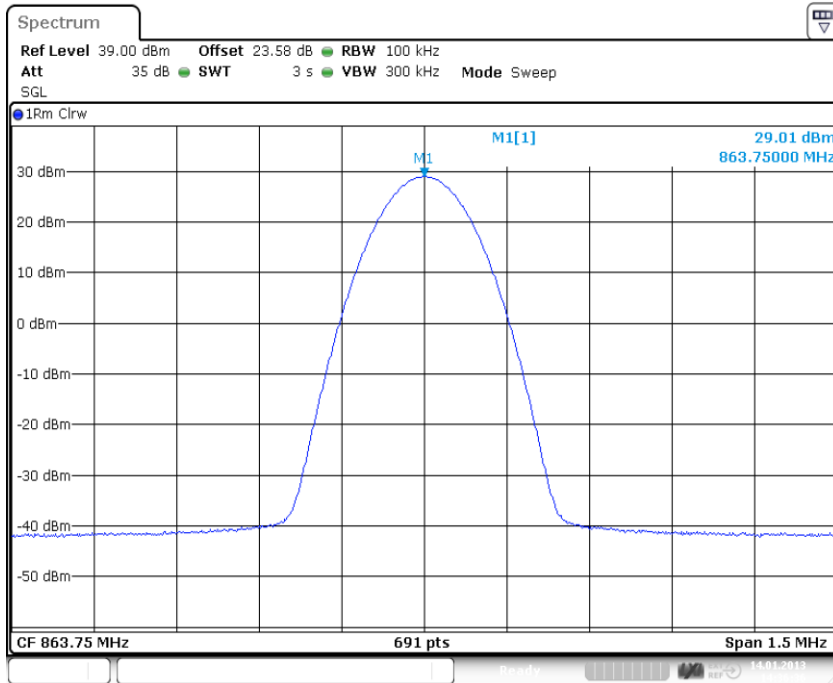

Date: 14.JAN.2013 14:36:36

plot 5.3.1.1-#1 RF Power Out: §90.635, §2.1046; Test Results; Downlink; Analog

5.3.1.2 GSM

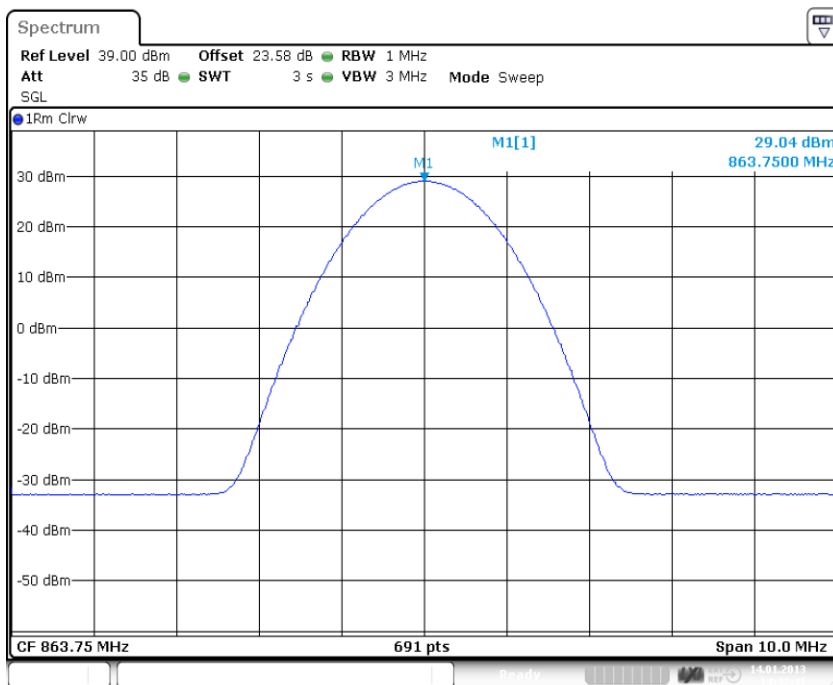

Date: 14.JAN.2013 14:42:41

plot 5.3.1.2-#1 RF Power Out: §90.635, §2.1046; Test Results; Downlink; GSM



5.3.1.3 EDGE

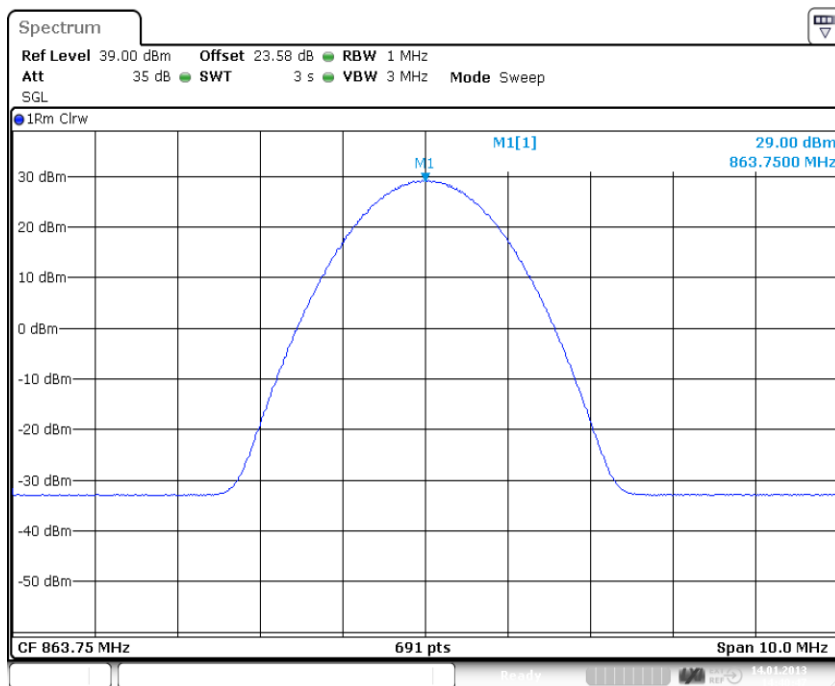

Date: 14.JAN.2013 14:40:47

plot 5.3.1.3-#1 RF Power Out: §90.635, §2.1046; Test Results; Downlink; EDGE

5.3.1.4 CDMA

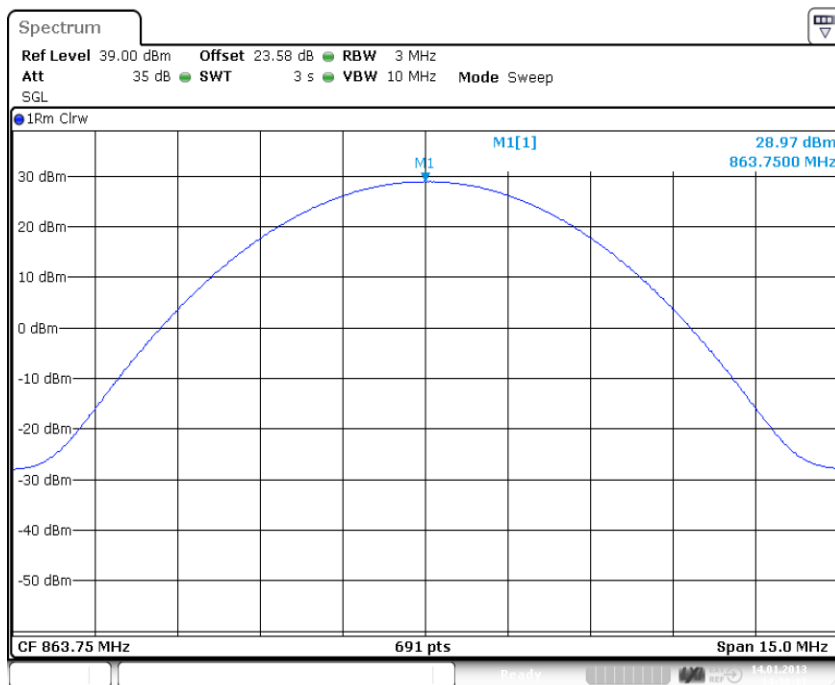

Date: 14.JAN.2013 14:38:11

plot 5.3.1.4-#1 RF Power Out: §90.635, §2.1046; Test Results; Downlink; CDMA

Test Report No.: 13-048

FCC ID: XS5-U7885L1719P

IC ID: 2237E-U7885L1719P



**BUREAU
VERITAS**

5.3.2 Uplink

n.a.

Note: The EUT does not transmit over the air in the uplink direction.

5.4 Summary test result

Test result	complies, according the plots above
Tested by:	M. Leinfelder
Date:	14.01.2013



6 Occupied Bandwidth: §90.210, §2.1049

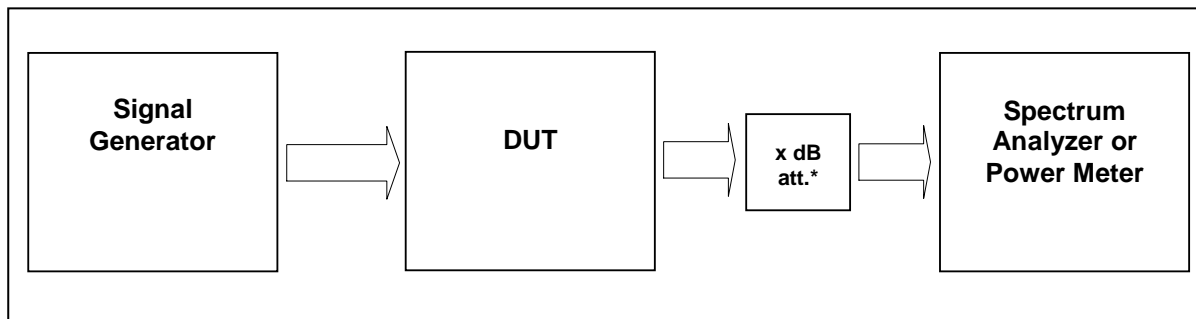

External Attenuator DL x dB = 20 dB
figure 6-#1 Test setup: Occupied Bandwidth: §90.210, §2.1049

Measurement uncertainty	± 0,38 dB
Test equipment used	9054, 9046, 7444; 7306; 7144; 7454;7453; 7341; 7449; 7368

6.1 Limit

The spectral shape of the output should look similar to input for all modulations.

6.2 Test method

Para. No.2.1049

The occupied bandwidth, that is the frequency bandwidth such that, below its lower and above its upper frequency limits, the mean powers radiated are each equal to 0.5 percent of the total mean power radiated by a given emission shall be measured under the following conditions as applicable:

6.3 Test results

6.3.1 Downlink

Detector RMS.

Modulation	Measured at		RBW VBW Span	Occupied Bandwidth	Plot #
Analog	Middle	863.75 MHz	1 kHz 10 kHz 125 kHz	0.0090 MHz	6.3.1.1 #1, #2
GSM	Middle	863.75 MHz	3 kHz 30 kHz 1 MHz	0.191 MHz	6.3.1.2 #1, #2
EDGE	Middle	863.75 MHz	3 kHz 30 kHz 1 MHz	0.19 MHz	6.3.1.3 #1, #2
CDMA	Middle	863.75 MHz	30 kHz 300 kHz 5 MHz	1.172 MHz	6.3.1.4 #1, #2

table 6.3-#1 Occupied Bandwidth: §90.210, §2.1049 Test results



6.3.1.1 Analog

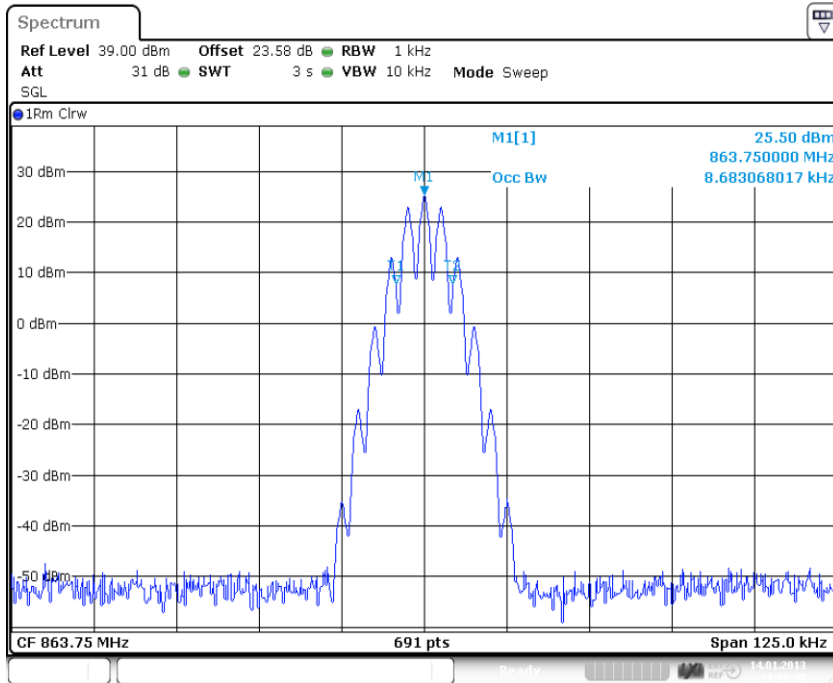

Date: 14.JAN.2013 14:36:46

plot 6.3.1.1-#1 Occupied Bandwidth: §90.210, §2.1049; Test results; Downlink; Analog Output

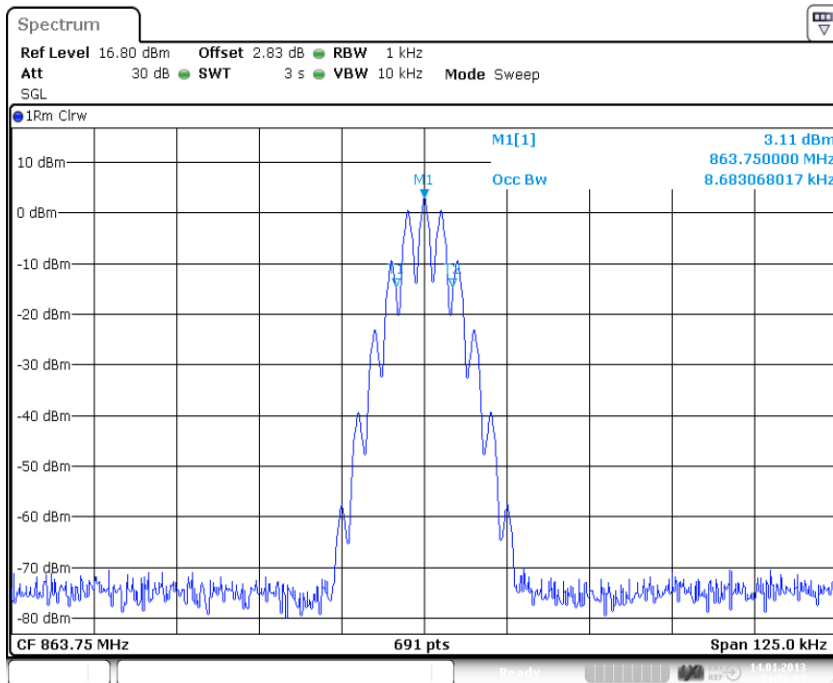

Date: 14.JAN.2013 14:36:53

plot 6.3.1.1-#2 Occupied Bandwidth: §90.210, §2.1049; Test results; Downlink; Analog Input



6.3.1.2 GSM

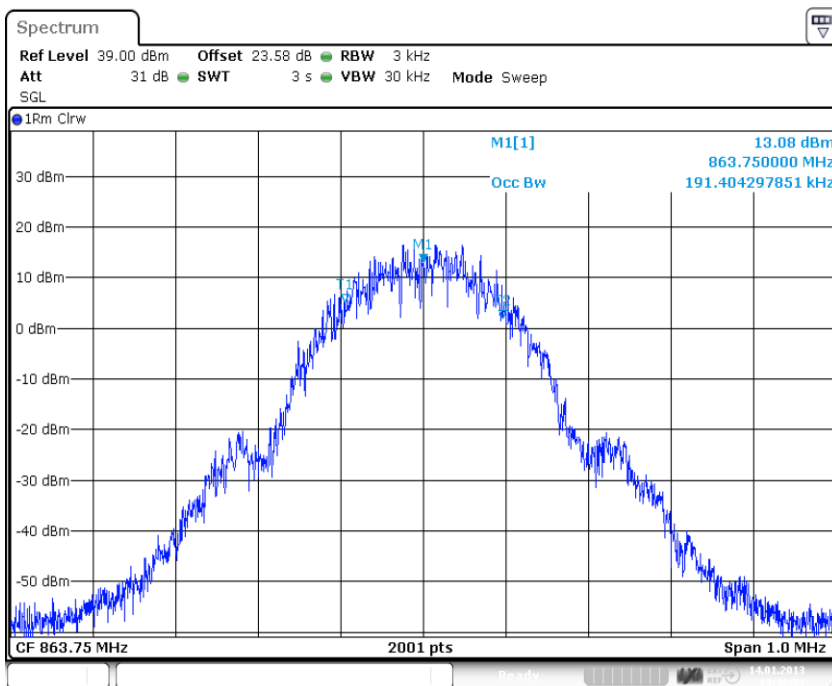

Date: 14.JAN.2013 14:42:51

plot 6.3.1.2-#1 Occupied Bandwidth: \$90.210, \$2.1049; Test results; Downlink; GSM Output

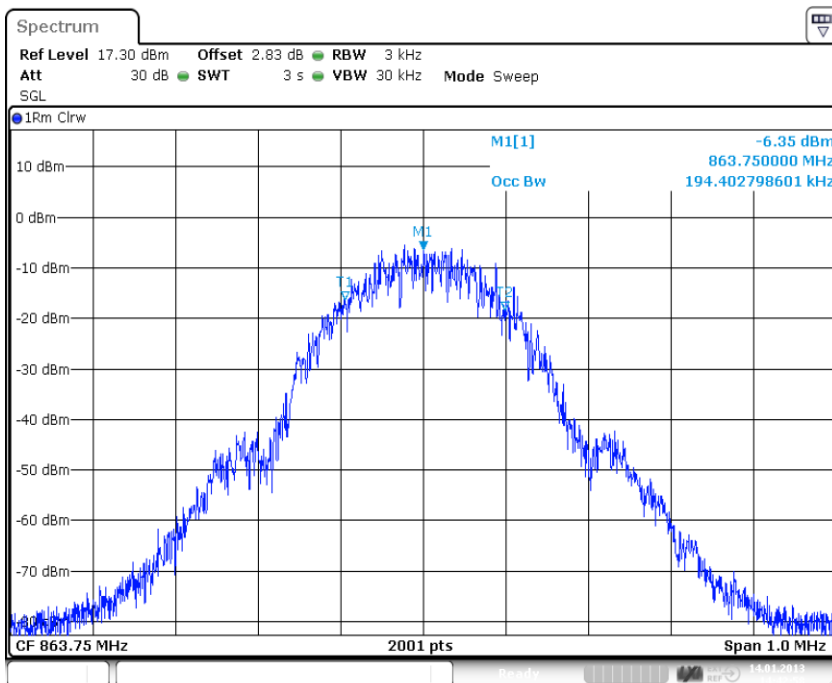

Date: 14.JAN.2013 14:42:57

plot 6.3.1.2-#2 Occupied Bandwidth: \$90.210, \$2.1049; Test results; Downlink; GSM Input



6.3.1.3 EDGE

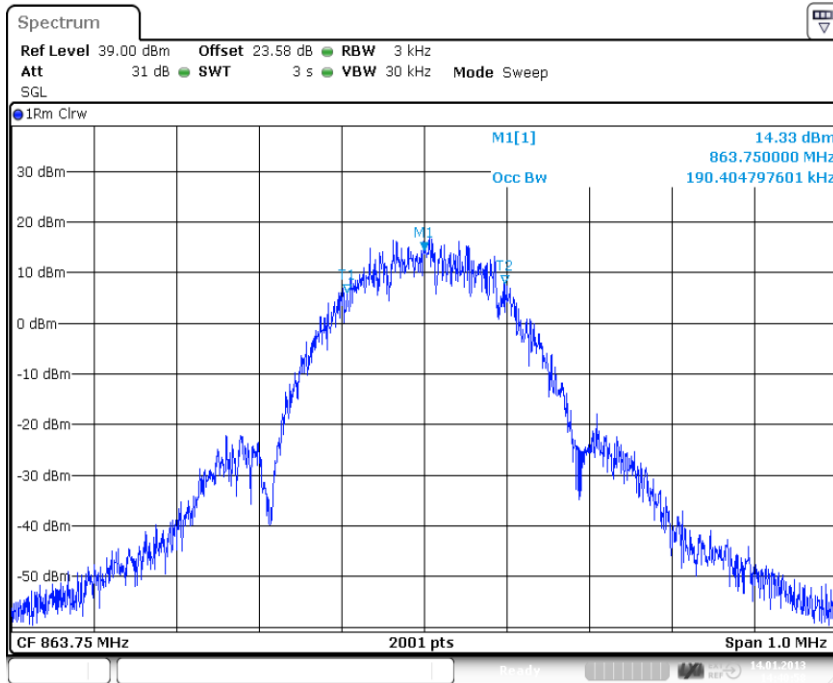

Date: 14.JAN.2013 14:40:58

plot 6.3.1.3-#1 Occupied Bandwidth: §90.210, §2.1049; Test results; Downlink; EDGE Output

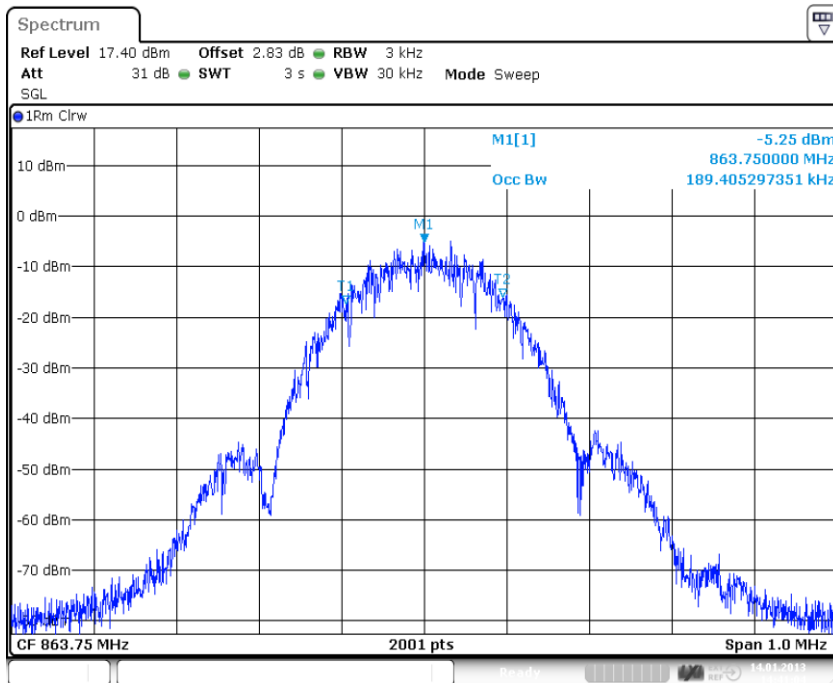

Date: 14.JAN.2013 14:41:04

plot 6.3.1.3-#2 Occupied Bandwidth: §90.210, §2.1049; Test results; Downlink; EDGE Input



6.3.1.4 CDMA

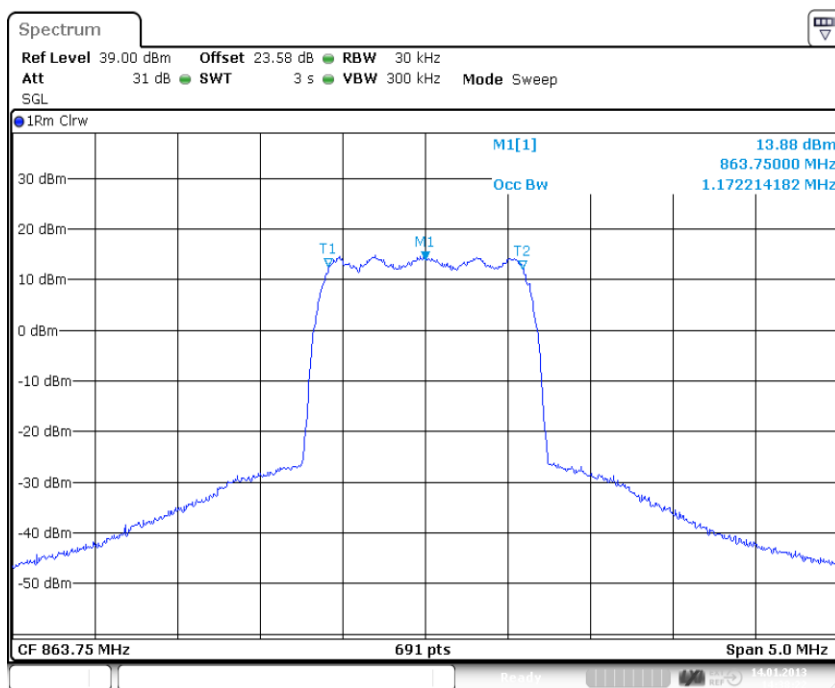

Date: 14.JAN.2013 14:38:22

plot 6.3.1.4-#1 Occupied Bandwidth: §90.210, §2.1049; Test results; Downlink; CDMA Output

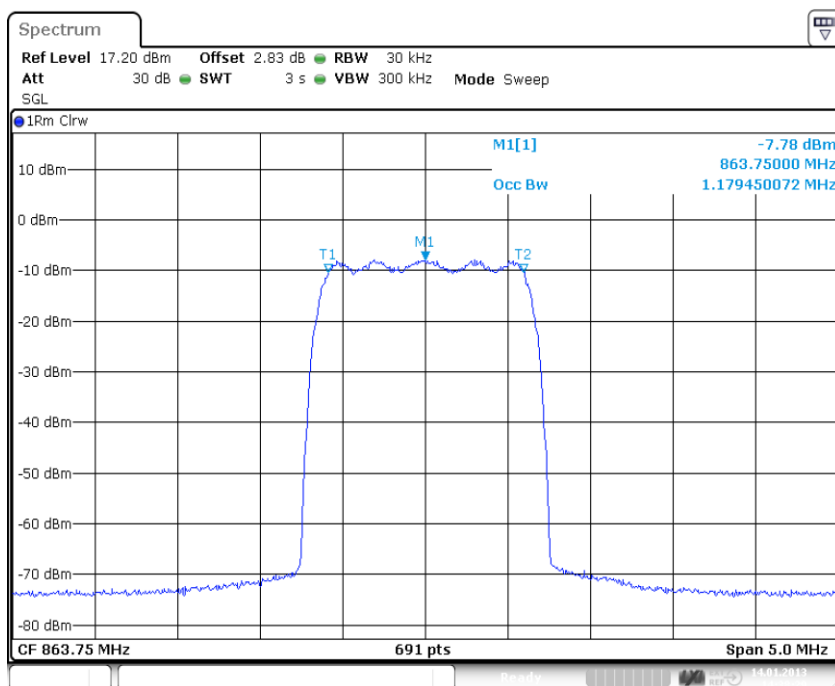

Date: 14.JAN.2013 14:38:28

plot 6.3.1.4-#2 Occupied Bandwidth: §90.210, §2.1049; Test results; Downlink; CDMA Input

Test Report No.: 13-048

FCC ID: XS5-U7885L1719P

IC ID: 2237E-U7885L1719P



**BUREAU
VERITAS**

6.3.2 Uplink

n.a.

Note: The EUT does not transmit over the air in the uplink direction.

6.4 Summary test result

Test result	complies, according the plots above
Tested by:	M. Leinfelder
Date:	14.01.2013



7 Spurious Emissions at Antenna Terminals: §90.210, §2.1051

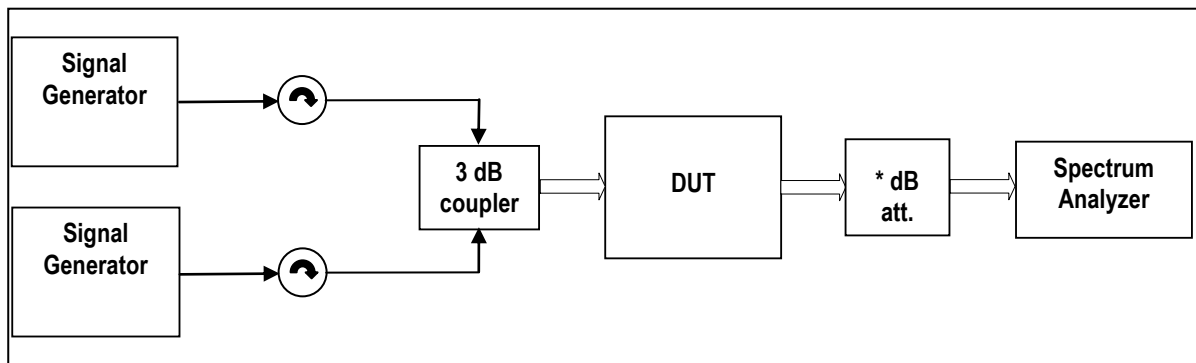

External Attenuator DL x dB = 0 dB

figure 7-#1 Test setup: Spurious Emissions at Antenna Terminals: §90.210, §2.1051

Measurement uncertainty	± 0,54 dB ± 1,2 dB ± 1,5 dB	9 kHz to 3 GHz 3 GHz to 7 GHz 7 GHz to 26 GHz
Test equipment used	9054, 9046, 8849; 7444; 7443; 7306; 7307; 7144; 7454; 7453; 7341; 7449; 7368	

7.1 Limit

Minimum standard: §90.210, Table “Application Emission Mask”

Frequency Band (MHz)	Mask for equipment with Audio Low pass filter	Mask for Equipment without audio low pass filter
806–809/851–854	B	H
809–824/854–869 ³	B	G

MASK	Spurious Limit
A,B,C,G,H,I	-13dBm

§ 90.691 Emission mask requirements for EA-based systems.

(a) Out-of-band emission requirement shall apply only to the “outer” channels included in an EA license and to spectrum adjacent to interior channels used by incumbent licensees. The emission limits are as follows:

(1) For any frequency removed from the EA licensee's frequency block by up to and including 37.5 kHz, the power of any emission shall be attenuated below the transmitter power (P) in watts by at least $116 \log_{10}(f/6.1)$ decibels or $50 + 10 \log_{10}(P)$ decibels or 80 decibels, whichever is the lesser attenuation, where f is the frequency removed from the center of the outer channel in the block in kilohertz and where f is greater than 12.5 kHz.

(2) For any frequency removed from the EA licensee's frequency block greater than 37.5 kHz, the power of any emission shall be attenuated below the transmitter power (P) in watts by at least $43 + 10 \log_{10}(P)$ decibels or 80 decibels, whichever is the lesser attenuation, where f is the frequency removed from the center of the outer channel in the block in kilohertz and where f is greater than 37.5 kHz.

(b) When an emission outside of the authorized bandwidth causes harmful interference, the Commission may, at its discretion, require greater attenuation than specified in this section.



$$x[dBm] = P[dBm] - (50 + 10 \log(P[W]))$$

$$x[dBm] = P[dBm] - (50 + 10 \log(\frac{P[mW]}{1000}))$$

$$x[dBm] = P[dBm] - (50 + P[dBm] - 30)$$

$$x[dBm] = -20$$

The worst-case emission limit is **-20 dBm**. In the range out of the licensee's frequency block up to 14.04 kHz the emission limit is higher than -20 dBm. (f = 12.5 kHz => limit = -7.14 dBm; f = 14.04 kHz => Limit = -20 dBm, see next page)

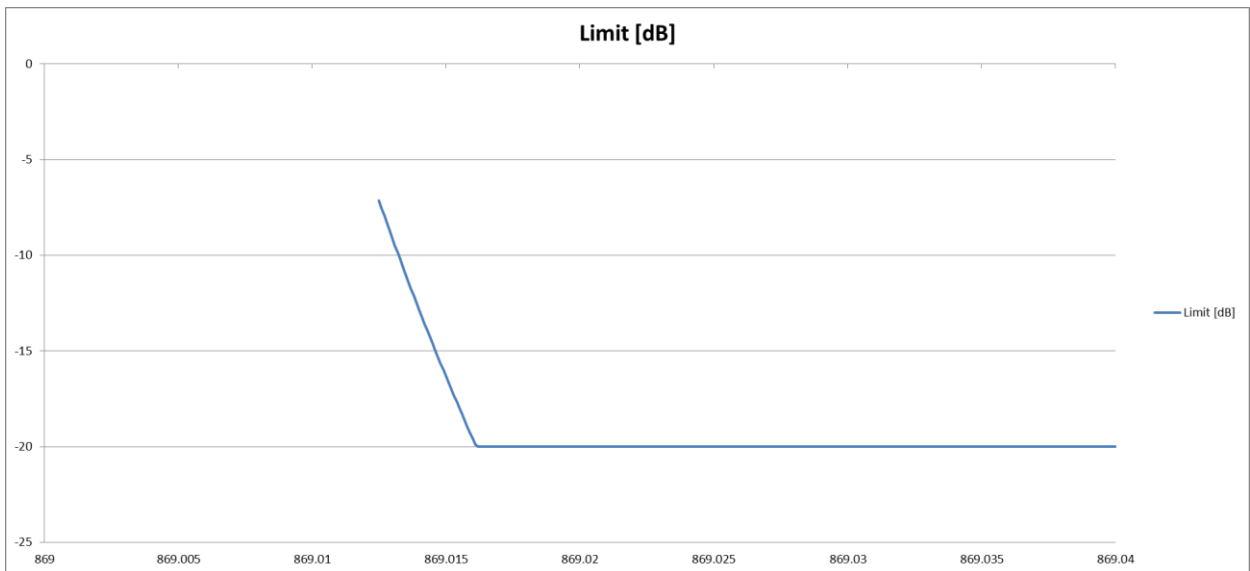
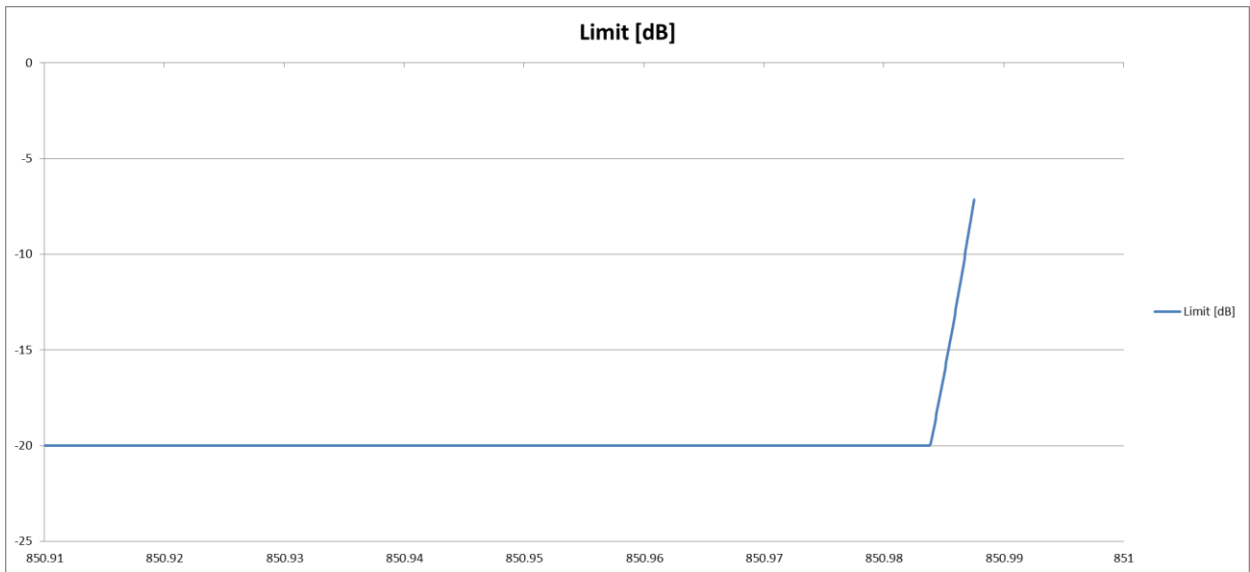



7.2 Test method

Para. No 2.1051 Measurements required: Spurious emissions at antenna terminals.

The radio frequency voltage or powers generated within the equipment and appearing on a spurious frequency shall be checked at the equipment output terminals when properly loaded with a suitable artificial antenna. Curves or equivalent data shall show the magnitude of each harmonic and other spurious emission that can be detected when the equipment is operated under the conditions specified in § 2.1049 as appropriate. The magnitude of spurious emissions which are attenuated more than 20 dB below the permissible value need not be specified.

[39 FR 5919, Feb. 15, 1974. Redesignated and amended at 63 FR 36599, July 7, 1998]

7.3 Test results

7.3.1 Downlink

<1MHz from Band Edge

Detector: RMS

Modulation	Measured at Band Edge	Carriers	RBW VBW Span Sweep points	Max. level (dBm)	Plot
Analog	Lower Edge Upper Edge	851.0125 MHz 851.0375 MHz 868.9625 MHz 868.9875 MHz	300 Hz 3 kHz 1.1 MHz 15000 points	-35.1	7.3.1.1 #1 #2
GSM	Lower Edge Upper Edge	851.3 MHz 851.7 MHz 868.5 MHz 868.7 MHz	3 kHz 30 kHz 2 MHz 3000 points	-40.9	7.3.1.2 #1 #2
EDGE	Lower Edge Upper Edge	851.3 MHz 851.7 MHz 868.5 MHz 868.7 MHz	3 kHz 30 kHz 2 MHz 3000 points	-42.8	7.3.1.3 #1 #2
CDMA	Lower Edge Upper Edge	852.875 MHz 854.125 MHz 865.875 MHz 867.125 MHz	30 kHz 300 kHz 10 MHz 1500 points	-30.3	7.3.1.4 #1 #2

table 7.3-#1 Spurious Emissions at Antenna Terminals: §90.210, §2.1051 Test results <1MHz from Band Edge

>1MHz from Band Edge



Detector: RMS

Modulation	Carrier	RBW VBW Span	Max. level (dBm)	Plot
Analog	860 MHz	1MHz 3MHz 30MHz – 8GHz	-29.7	7.3.1.5 #1
GSM	860 MHz	1MHz 3MHz 30MHz – 8GHz	-30.5	7.3.1.6 #1
EDGE	860 MHz	1MHz 3MHz 30MHz – 8GHz	-29.9	7.3.1.7 #1
CDMA	860 MHz	1MHz 3MHz 30MHz – 8GHz	-29.7	7.3.1.8 #1

table 7.3-#2 Spurious Emissions at Antenna Terminals: §90.210, §2.1051 Test results <1MHz from Band Edge

7.3.1.1 Analog < 1MHz to band edge

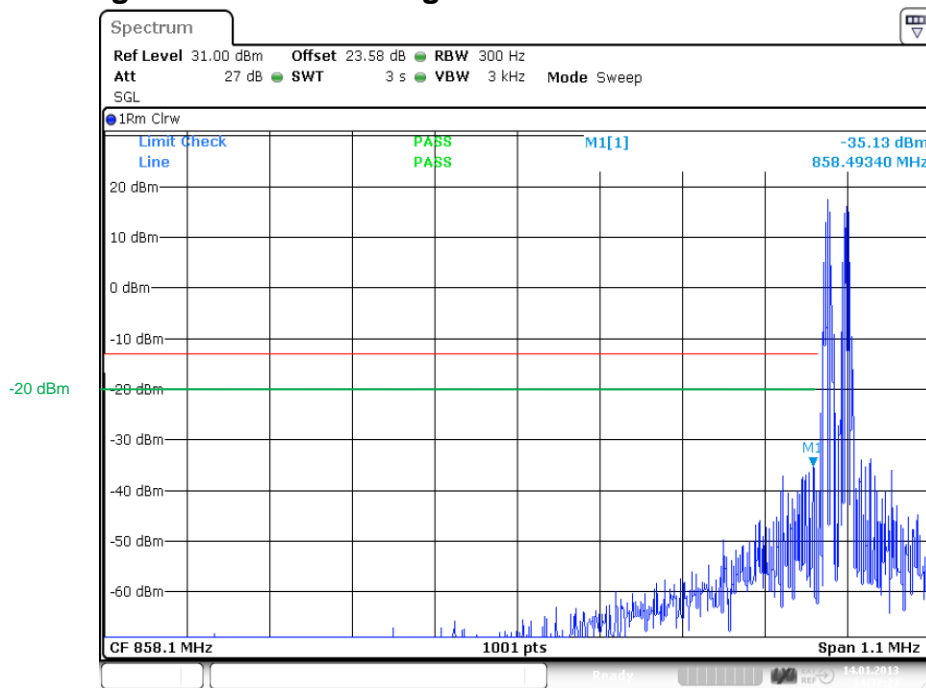

Date: 14.JAN.2013 14:37:22

plot 7.3.1.1-#1 Spurious Emissions at Antenna Terminals: §90.210, §2.1051; Test results; Downlink; Analog < 1MHz to band edge; Lower Band Edge

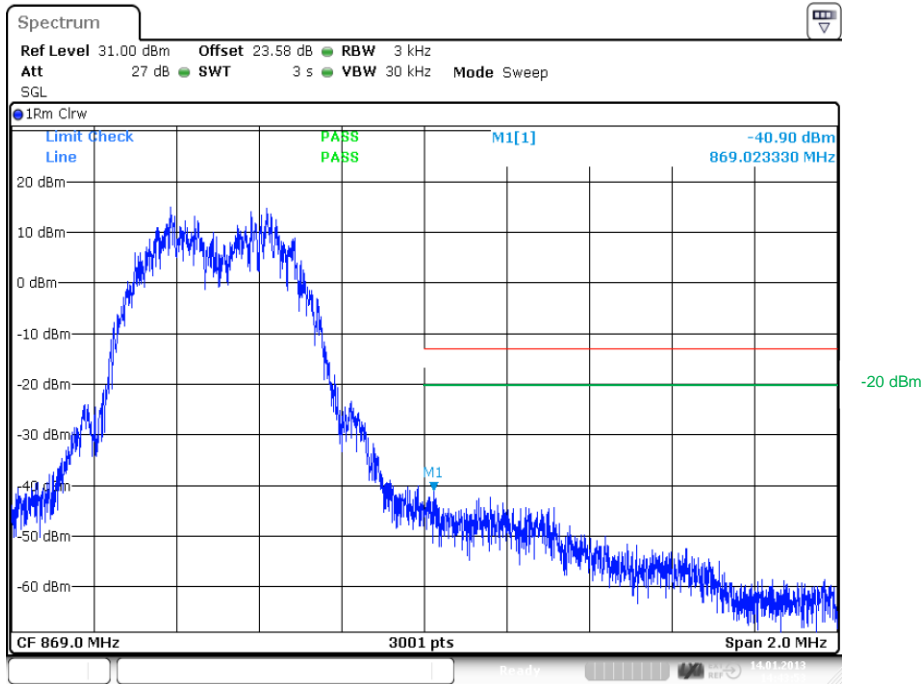

plot 7.3.1.2-#2 Spurious Emissions at Antenna Terminals: §90.210, §2.1051; Test results; Downlink; GSM < 1MHz to band edge; Upper Band Edge

7.3.1.3 EDGE < 1MHz to band edge

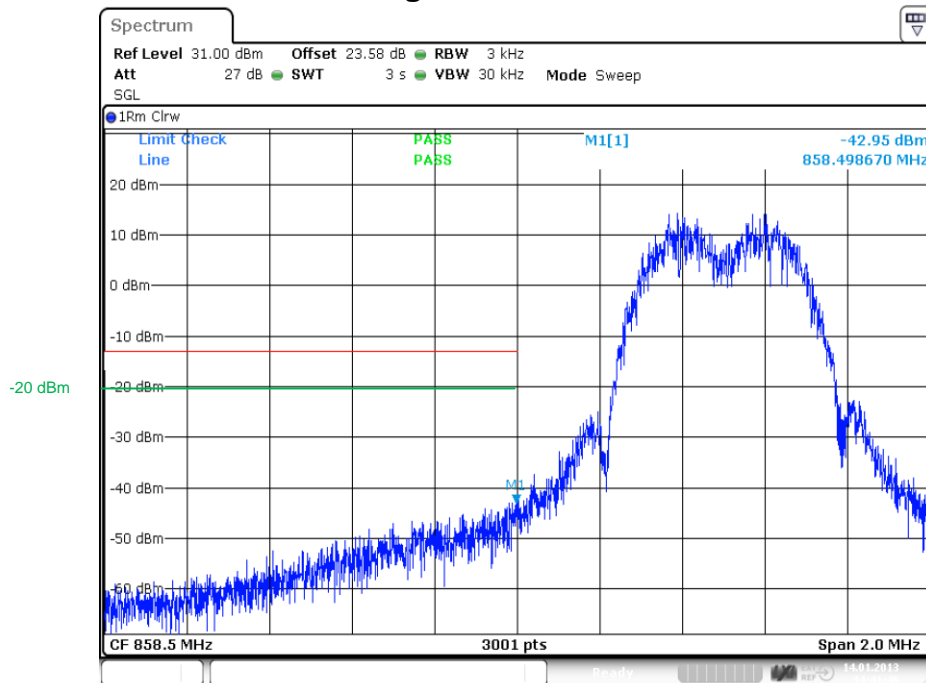

plot 7.3.1.3-#1 Spurious Emissions at Antenna Terminals: §90.210, §2.1051; Test results; Downlink; EDGE < 1MHz to band edge; Lower Band Edge

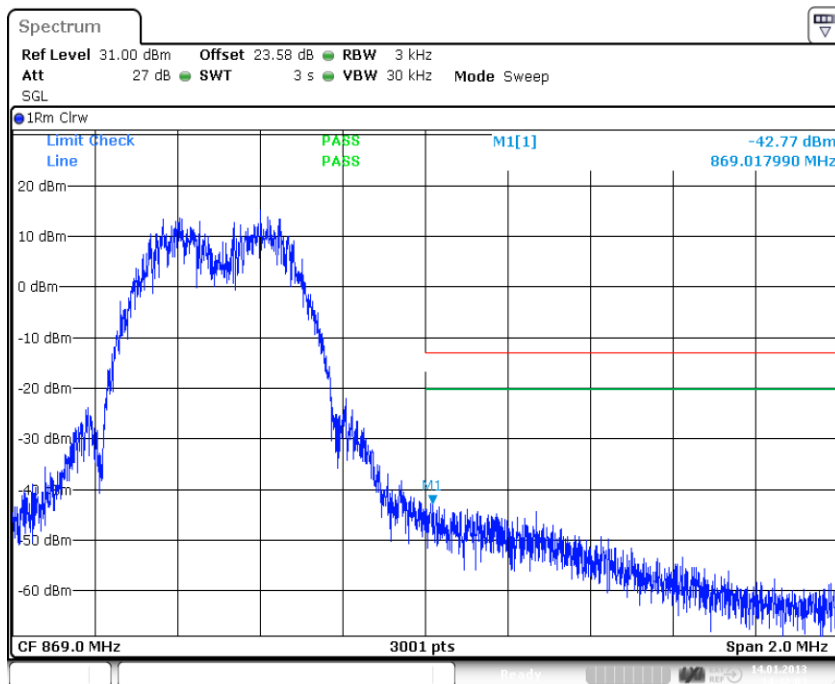

Date: 14.JAN.2013 14:42:03

plot 7.3.1.3-#2 Spurious Emissions at Antenna Terminals: §90.210, §2.1051; Test results; Downlink; EDGE < 1MHz to band edge; Upper Band Edge

7.3.1.4 CDMA < 1MHz to band edge

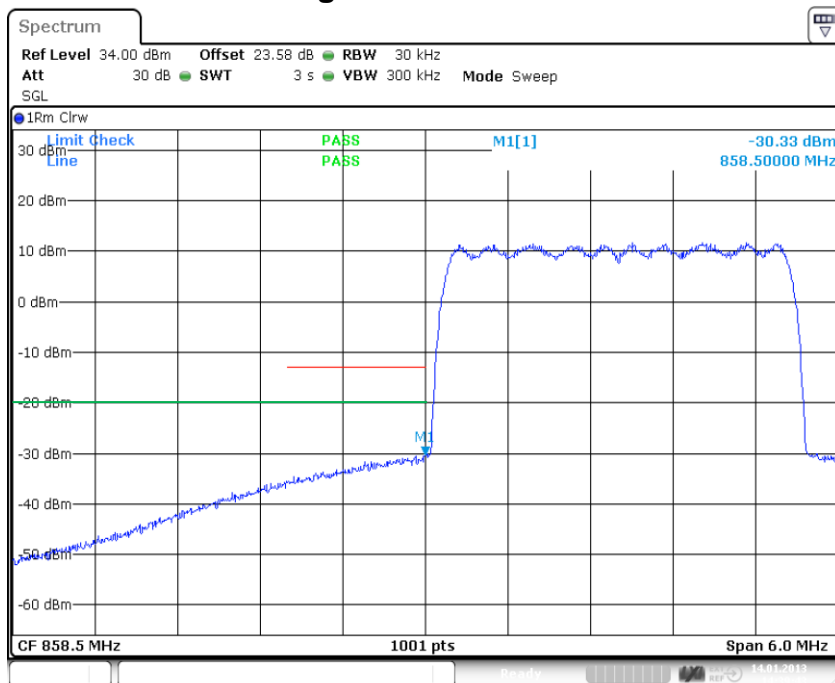

Date: 14.JAN.2013 14:39:43

plot 7.3.1.4-#1 Spurious Emissions at Antenna Terminals: §90.210, §2.1051; Test results; Downlink; CDMA < 1MHz to band edge; Lower Band Edge



7.3.1.6 GSM > 1MHz to band edge

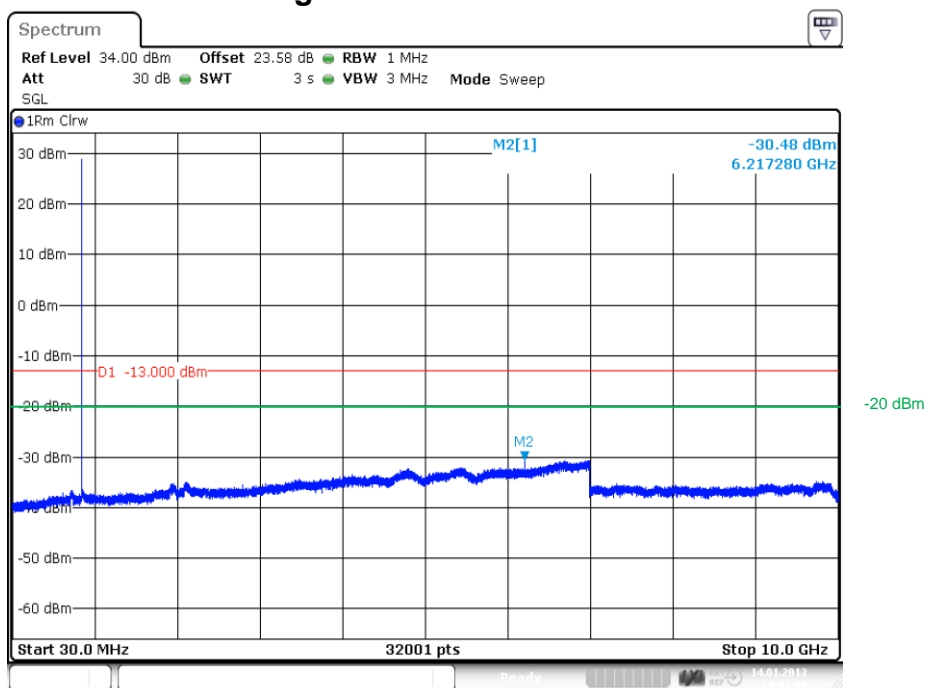

Date: 14.JAN.2013 14:43:04

plot 7.3.1.6-#1 Spurious Emissions at Antenna Terminals: §90.210, §2.1051; Test results; Downlink; GSM > 1MHz to band edge

7.3.1.7 EDGE > 1MHz to band edge

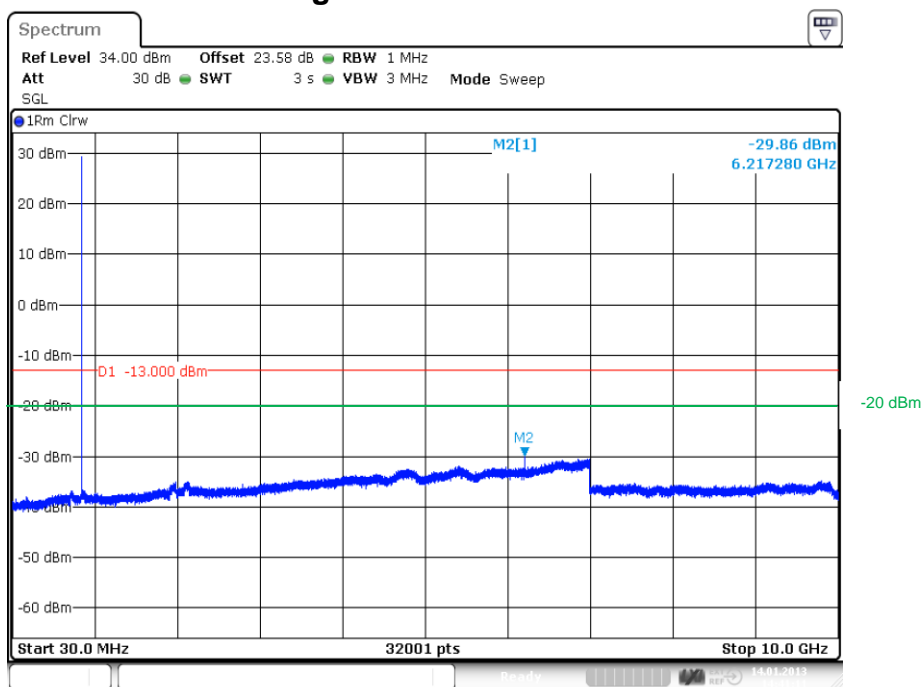

Date: 14.JAN.2013 14:41:11

plot 7.3.1.7-#1 Spurious Emissions at Antenna Terminals: §90.210, §2.1051; Test results; Downlink; EDGE > 1MHz to band edge



7.3.1.8 CDMA > 1MHz to band edge

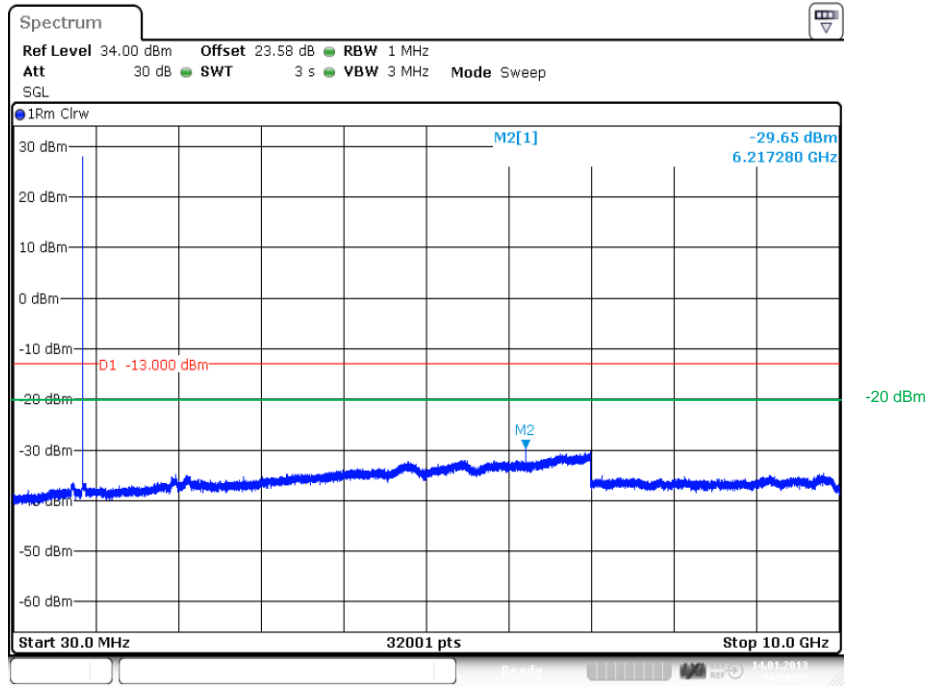

Date: 14.JAN.2013 14:38:35

plot 7.3.1.8-#1 Spurious Emissions at Antenna Terminals: §90.210, §2.1051; Test results; Downlink; CDMA > 1MHz to band edge

7.3.2 Uplink

n.a.

Note: The EUT does not transmit over the air in the uplink direction.

7.4 Summary test result

Test result	complies, according the plots above
Tested by:	M. Leinfelder
Date:	14.01.2013



8 Amplifier Gain and Bandwidth: IC RSS-131

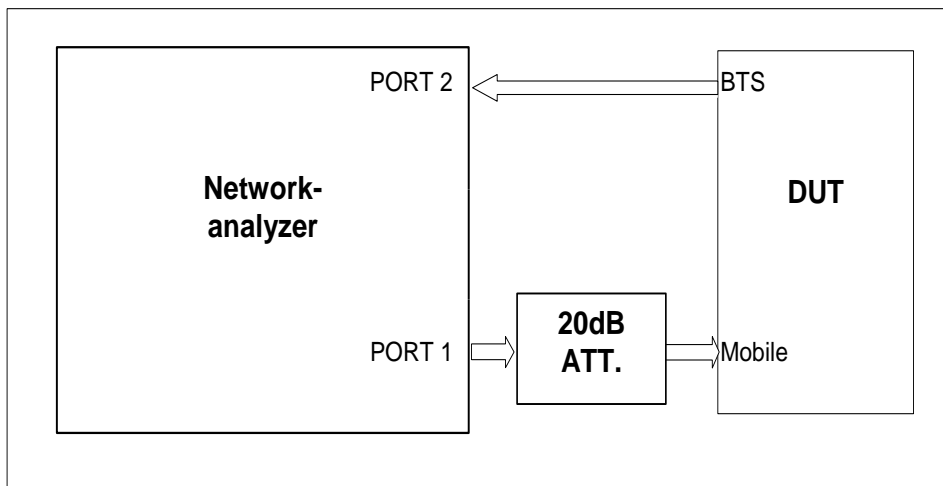

figure 8-#1 Test setup: Amplifier Gain and Bandwidth: IC RSS-131

Test equipment used	9102; 7438; 7439; 7144; 7454;7453; 7341; 7449; 7368;
---------------------	--

8.1 Limit

IC RSS-131 clause 6.1

The passband gain shall not exceed the nominal gain by more than 1.0 dB. The 20 dB bandwidth shall not exceed the nominal bandwidth that is stated by the manufacturer. Outside of the 20 dB bandwidth, the gain shall not exceed the gain at the 20 dB point.

8.2 Test method

IC RSS-131 clause 4.2

Adjust the internal gain control of the equipment under test to the nominal gain for which equipment certification is sought.

With the aid of a signal generator and spectrum analyser, measure the 20 dB bandwidth of the amplifier (i.e. at the point where the gain has fallen by 20 dB). Measure the gain-versus-frequency response of the amplifier from the midband frequency f_0 of the passband up to at least $f_0 \pm 250\%$ of the 20 dB bandwidth.

8.3 Test results

8.3.1 Downlink

Passband gain	49.7 dB
Lower limit of 20dB Bandwidth	854.4 MHz
Upper limit of 20dB Bandwidth	897.8 MHz
20dB Bandwidth	43.32 MHz

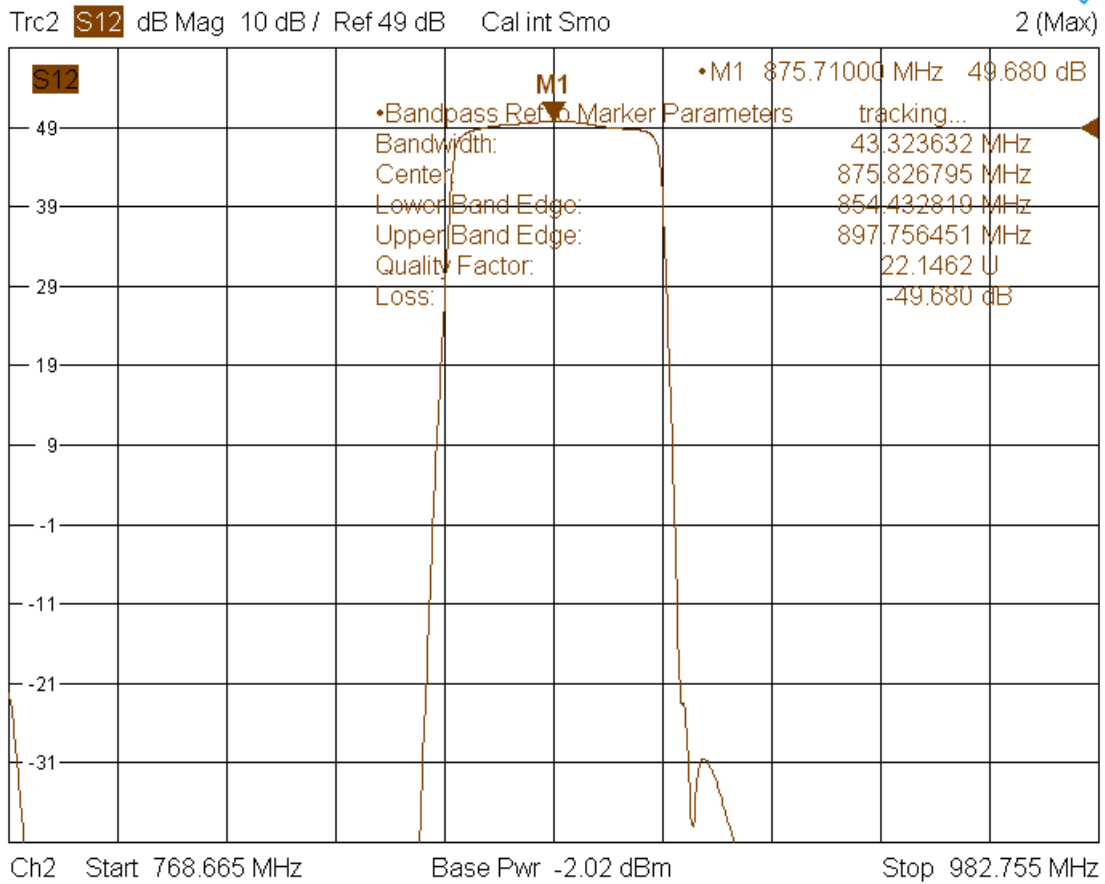

1/15/2013, 2:01 PM

plot 8.3.1-#1 Amplifier Gain and Bandwidth: IC RSS-131; Test results; Downlink

8.3.2 Uplink

n.a.

Note: The EUT does not transmit over the air in the uplink direction.

8.4 Summary test result

Test result	complies, according the plots above
Tested by:	M. Leinfelder
Date:	15.01.2013



9 Output Power: IC RSS-131

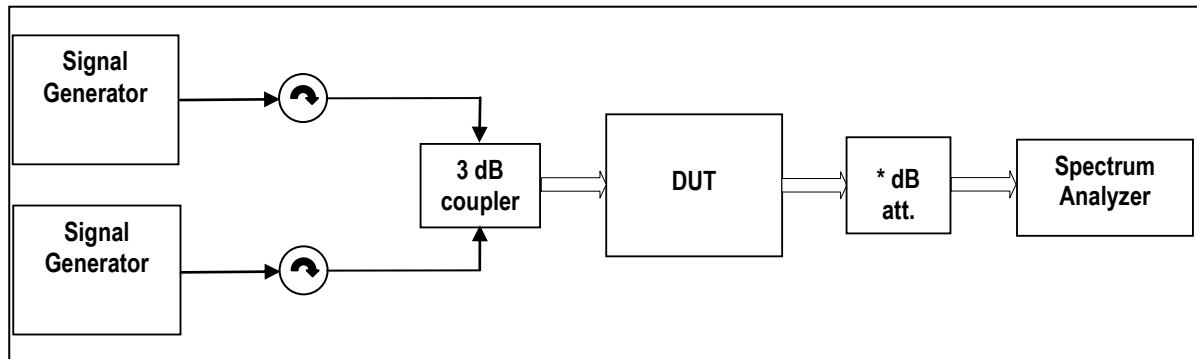

External Attenuator DL x dB = 20 dB
figure 9-#1 Test setup: Output Power: IC RSS-131

Measurement uncertainty	± 0,38 dB
Test equipment used	9054, 9046, 8849; 7444; 7443; 7306; 7307; 7144; 7454; 7453; 7341; 7449; 7368

9.1 Limit

IC RSS-131 clause 6.2

The manufacturer's output power rating P rated MUST NOT be greater than P mean for all types of enhancers.

9.2 Test method

IC RSS-131 clause 4.3.1 Multi-channel Enhancer

The following subscript "o" denotes a parameter at the enhancer output point.

Connect two signal generators to the input of the Device Under Test (DUT), via a proper impedance matching network (and preferably via a variable attenuator) so that the two input signals are equal sinusoids (and can be raised equally).

Connect a dummy load of suitable load rating to the enhancer output point. Connect also a spectrum analyser to this output point via a coupling network and attenuator, so that only a portion of the output signal is coupled to the spectrum analyser. The coupling attenuation shall be stated in the test report.

Set the two generator frequencies f_1 and f_2 such that they and their third-order intermodulation product frequencies, $f_3 = 2f_1 - f_2$ and $f_4 = 2f_2 - f_1$, are all within the passband of the DUT.

Raise the input level to the DUT while observing the output tone levels, P_{o1} and P_{o2} , and the intermodulation product levels, P_{o3} and P_{o4} .

For enhancers rated 500 watts or less: Raise the input level to the DUT until the greater level of the intermodulation products at the enhancer output terminals, P_{o3} or P_{o4} , equals -43 dBW.

For enhancers rated over 500 watts: Raise the input level to the DUT until the greater level of the intermodulation products at the enhancer output terminals, P_{o3} or P_{o4} , is 67 dB below the level of either output tone level, P_{o1} or P_{o2} .

Record all signal levels and their frequencies. Calculate the mean output power (P_{mean}) under this testing condition using $P_{mean} = P_{o1} + 3$ dB.



9.3 Test results

9.3.1 Downlink

P_{01} @ f_1	26.1 dBm @ 862.25 MHz
P_{02} @ f_2	26.1 dBm @ 865.25 MHz
P_{03} @ f_3	-22.8 dBm @ 859.25 MHz
P_{04} @ f_4	-26.5 dBm @ 868.24 MHz

$$P_{\text{mean}} = P_{01} + 3 \text{ dB}$$

$$P_{\text{mean}} = 26.1 \text{ dBm} + 3 \text{ dB} = 29.1 \text{ dBm}$$

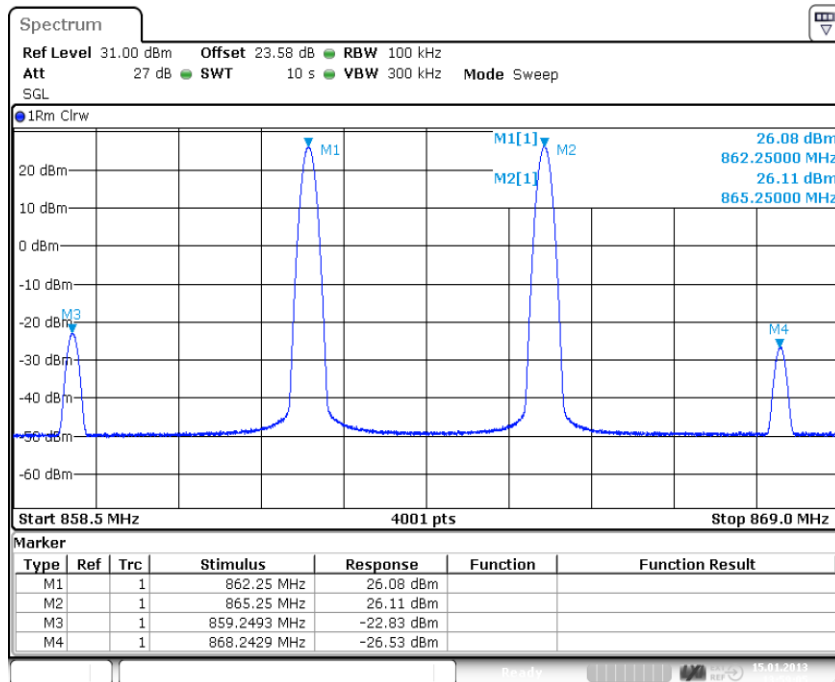

Date: 15.JAN.2013 13:59:06

plot 9.3.1-#1 Output Power: IC RSS-131; Test results; Downlink

9.3.2 Uplink

n.a.

Note: The EUT does not transmit over the air in the uplink direction.

9.4 Summary test result

Test result	complies, according the plots above
Tested by:	M. Leinfelder
Date:	15.01.2013



10 Non-Linearity: IC RSS-131

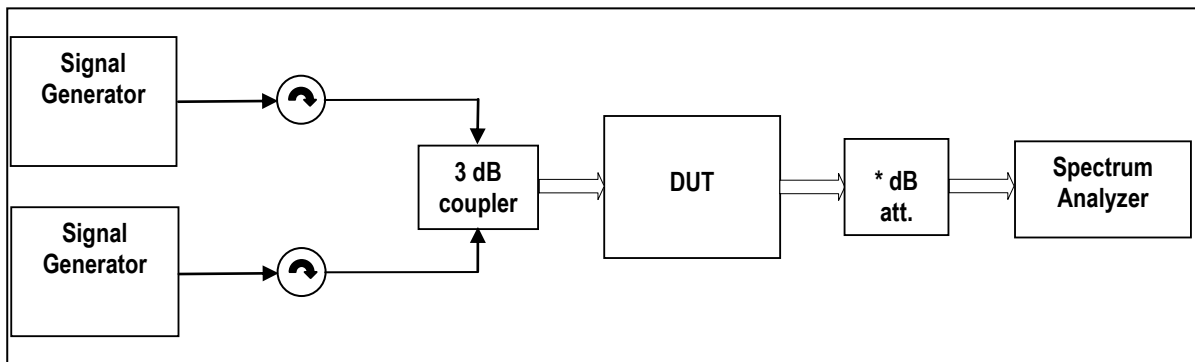

External Attenuator DL x dB = 20 dB
figure 10-#1 Test setup: Non-Linearity: IC RSS-131

Test equipment used	9054, 9046, 8849; 7444; 7443; 7306; 7307; 7144; 7454; 7453; 7341; 7449; 7368
---------------------	--

10.1 Limit

RSS-131 clause 6.3

Transmitter signals amplified by a non-linear device (enhancer or translator) will alter the occupied bandwidth of the transmitted signals; therefore, the extent of non-linearity shall be tested.

RSS-131 clause 6.3.1

For a multi-channel enhancer, any intermodulation product level must be attenuated, relative to P, by at least:

$$43 + 10 \text{ Log } 10 P, \text{ or } 70 \text{ dB, whichever is less stringent,}$$

where P is the total RF output power of the test tones in watts.

10.2 Test method

RSS-131 clause

IC RSS-131 clause 4.3.1 Multi-channel Enhancer

The following subscript "o" denotes a parameter at the enhancer output point.

Connect two signal generators to the input of the Device Under Test (DUT), via a proper impedance matching network (and preferably via a variable attenuator) so that the two input signals are equal sinusoids (and can be raised equally).

Connect a dummy load of suitable load rating to the enhancer output point. Connect also a spectrum analyser to this output point via a coupling network and attenuator, so that only a portion of the output signal is coupled to the spectrum analyser. The coupling attenuation shall be stated in the test report.

Set the two generator frequencies f_1 and f_2 such that they and their third-order intermodulation product frequencies, $f_3 = 2f_1 - f_2$ and $f_4 = 2f_2 - f_1$, are all within the passband of the DUT.

Raise the input level to the DUT while observing the output tone levels, P_{o1} and P_{o2} , and the intermodulation product levels, P_{o3} and P_{o4} .



10.3 Test results

10.3.1 Downlink

Requirement calculation:

$P = 26.1 \text{ dBm} = 0.41\text{W}$

Attenuation = $43 + 10\text{Log}_{10}(0.41\text{W})$ or 70 dB whichever is less stringent

Attenuation = 39.1 dB or 70 dB whichever is less stringent

Attenuation = 39.1 dB

Test result:

$\Delta P \text{ to IMD} = 26.1 \text{ dBm} - (-22.83 \text{ dBm}) = 48.93 \text{ dB}$

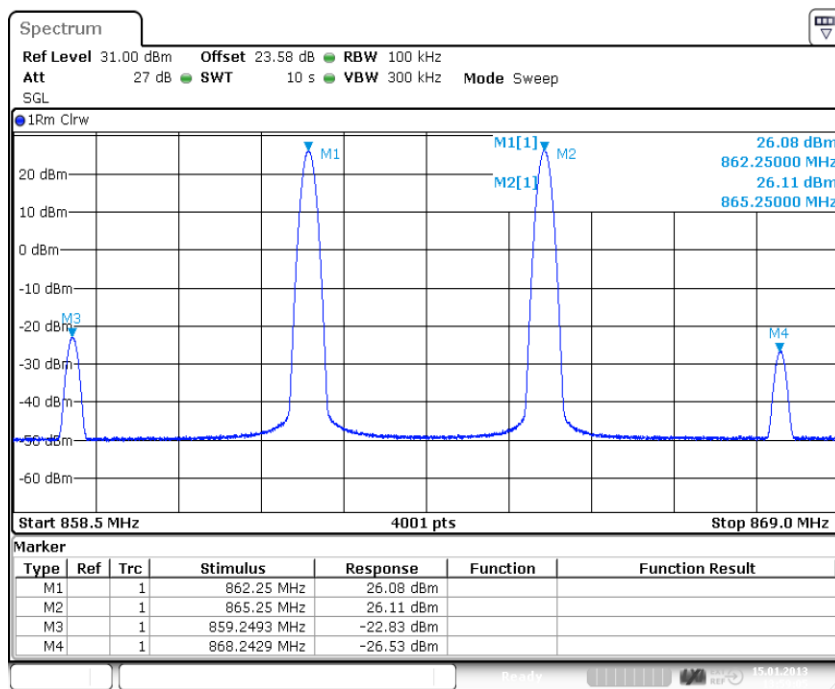

Date: 15.JAN.2013 13:59:06

plot 10.3.1-#1 Non-Linearity: IC RSS-131; Test results; Downlink

10.3.2 Uplink

n.a.

Note: The EUT does not transmit over the air in the uplink direction.

10.4 Summary test result

Test result	complies, according the plots above
Tested by:	M. Leinfelder
Date:	15.01.2013



11 Spurious Emissions: RSS-131

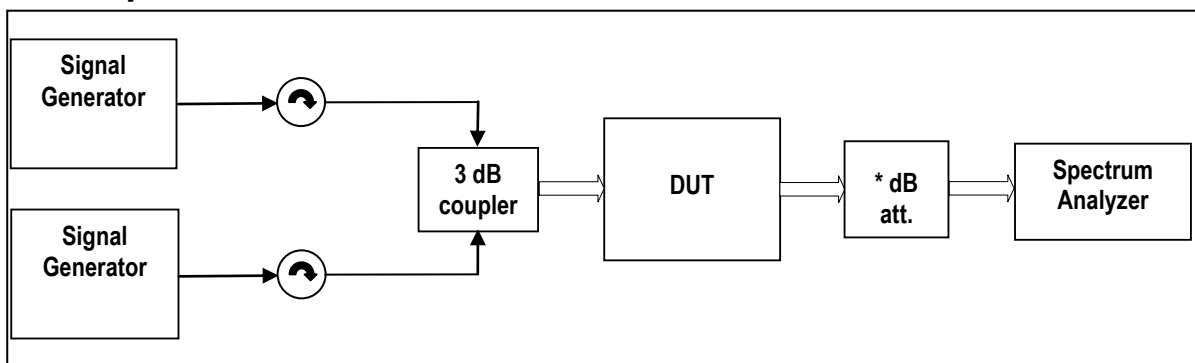

External Attenuator DL x dB = 30 dB
figure 11-#1 Test setup: Spurious Emissions: RSS-131

Measurement uncertainty	± 0,54 dB ± 1,2 dB ± 1,5 dB	9 kHz to 3 GHz 3 GHz to 7 GHz 7 GHz to 13,6 GHz
Test equipment used	9054, 9046, 8849; 7444; 7443; 7306; 7307; 7144; 7454; 7453; 7341; 7449; 7368	

11.1 Limit

RSS-131 clause 6.4

Spurious emissions of zone enhancers and translators shall be suppressed as much as possible.

Spurious emissions shall be attenuated below the rated power of the enhancer by at least:

$43 + 10 \log_{10}(P \text{ rated in watts})$, or 70 dB, whichever is less stringent.

11.2 Test method

RSS-131 clause 4.4.1

The spurious emissions of the equipment under test shall be measured using the two-tone method in section 4.3.1, with the two tones P_{01} and P_{02} set to the required levels.

Using a spectrum analyser with a resolution bandwidth set at 100 kHz, search for spurious emissions from 30 MHz to at least 5 times the highest RF passband frequency. The search may omit the band that contains the test tones and intermodulation products.

11.3 Test results

11.3.1 Downlink

Requirement calculation:

$P = 26.1 \text{ dBm} = 0.41\text{W}$

Attenuation = $43 + 10\log_{10}(0.41\text{W})$ or 70 dB whichever is less stringent

Attenuation = 39.1 dB or 70 dB whichever is less stringent

Attenuation = 39.1 dB

Test result:

Delta P to IMD = $26.1 \text{ dBm} - (-22.83 \text{ dBm}) = 48.93 \text{ dB}$

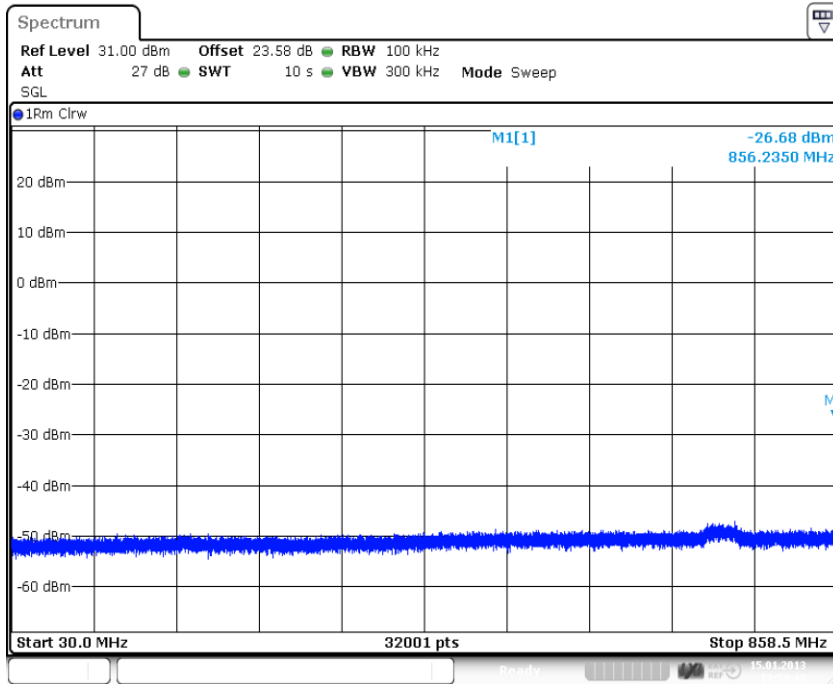

Date: 15.JAN.2013 13:59:19

plot 11.3.1-#1 Spurious Emissions: RSS-131; Test results; Downlink; 30 MHz – 851 MHz

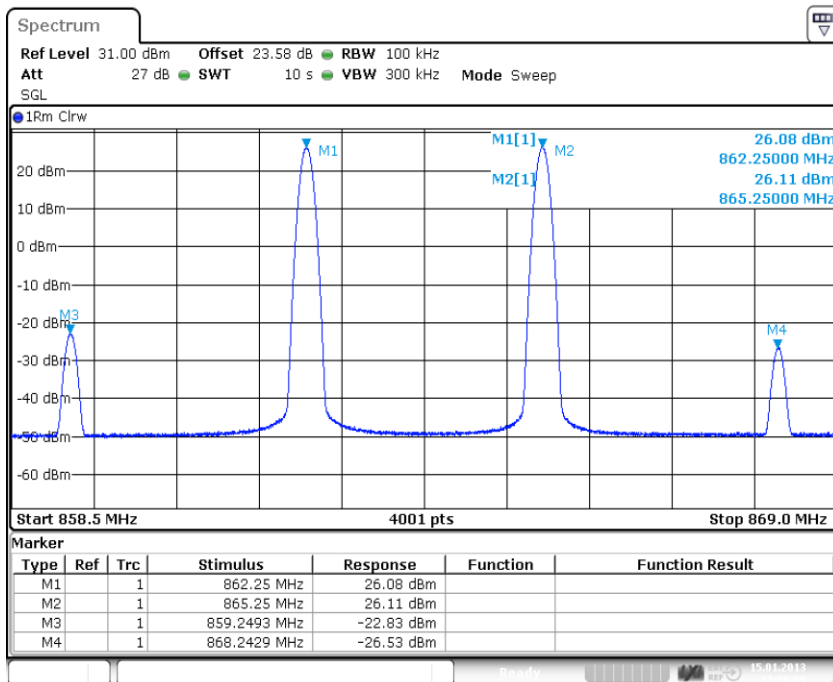

Date: 15.JAN.2013 13:59:06

plot 11.3.1-#2 Spurious Emissions: RSS-131; Test results; Downlink; 851 MHz – 869 MHz

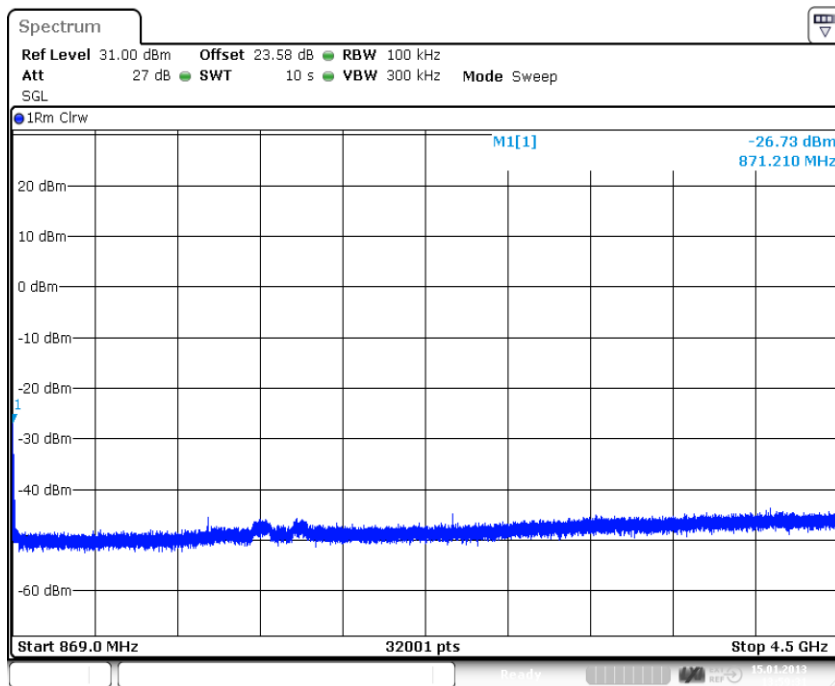

Date: 15.JAN.2013 13:59:32

plot 11.3.1-#3 Spurious Emissions: RSS-131; Test results; Downlink; 869 MHz – 4.5 GHz

11.3.2 Uplink

n.a.

Note: The EUT does not transmit over the air in the uplink direction.

11.4 Summary test result

Test result	complies, according the plots above
Tested by:	M. Leinfelder
Date:	15.01.2013

12 Radiated Spurious Emissions at the ECL (Bureau Veritas): §90.210, §90.691, §2.1053, RSS Gen, RSS-131



picture 8.1: label



picture 8.2: Test setup: Field Strength Emission in the SAC

Test Report No.: 13-048

FCC ID: XS5-U7885L1719P

IC ID: 2237E-U7885L1719P



BUREAU VERITAS

This clause specifies requirements for the measurement of radiated emission.

Frequency range	Distance: EUT <-> antenna / location	Limit	Test method
30 MHz - 1 GHz	3 metres / SAC	FCC 47 CFR Part 90.543	TIA/EIA-603-C:2004
		IC RSS-131 sec. 6.4	
1 GHz – 22 GHz	3 metres / SAC	FCC 47 CFR Part 90.543	
		IC RSS-131 sec. 6.4	

Test equipment used:

Designation	Type	Manufacturer	Invent.-no.	Cal.-date	due Cal.-date	used
EMI test receiver	ESI40	Rohde & Schwarz	E1687	19.12.2012	19.12.2013	X
Antenna	CBL 6111	Chase	K1024	29.03.2012	29.03.2013	X
RF Cable	RG214	Frankonia	K1121 SET	20.02.2013	20.02.2014	X
Antenna	HL 025	R&S	K809	16.11.2012	16.11.2013	X
Preamplifier	AFS4-00102000	Miteq	K838	05.06.2012	05.06.2013	X
RF Cable	Sucoflex 100	Suhner	K1742	23.05.2012	23.05.2013	X

The REMI version 2.135 has been used for max search.

Test set-up:

Test location: SAC
 Both, the Fully Anechoic Chamber (FAC) and the Semi Anechoic Chamber (SAC) fulfil the requirements of ANSI C63.4 and CISPR 16-1-4 with regards to NSA and SVSWR.

Test Voltage: 115V / 60 Hz
 Type of EUT: Wall mounted

Measurement uncertainty:

Measurement uncertainty expanded (95% or K=2)	± 4,7 dB for ANSI C63.4 measurement ± 0,5 dB for TIA-603 measurement
--	---

12.1 Method of Measurement

Measurement procedure. TIA-603-C

The antenna substitution method is used to determine the equivalent radiated power at spurious frequencies. The spurious emissions are measured at a distance of 3 meters. The EUT is then replaced with a reference substitution antenna with a known gain referenced to a dipole. This antenna is fed with a signal at the spurious frequency. The level of the signal is adjusted to repeat the previously measured level. The resulting eirp is the signal level fed to the reference antenna corrected for gain referenced to an isotropic dipole (see Figure 7.2).

From KDB (AMPLIFIER, BOOSTER, AND REPEATER REMINDER SHEET):

Radiated spurs (enclosure) – Use of CW signal (low, mid. and high freq.) is acceptable rather than all modulations.

The maximum RFI field strength was determined during the measurement by rotating the turntable (± 180 degrees) and varying the height of the receive antenna ($h = 1 \dots 4$ m) as like defined in ANSI C63.4. A measurement receiver has been used with a RBW 120 kHz up to 1 GHz and 1 MHz above 1 GHz. Steps with during pre measurement was half the RBW.

Both, the Fully Anechoic Chamber (FAC) and the Semi Anechoic Chamber (SAC) fulfil the requirements of ANSI C63.4 and CISPR 16-1-4 with regards to NSA and SVSWR.

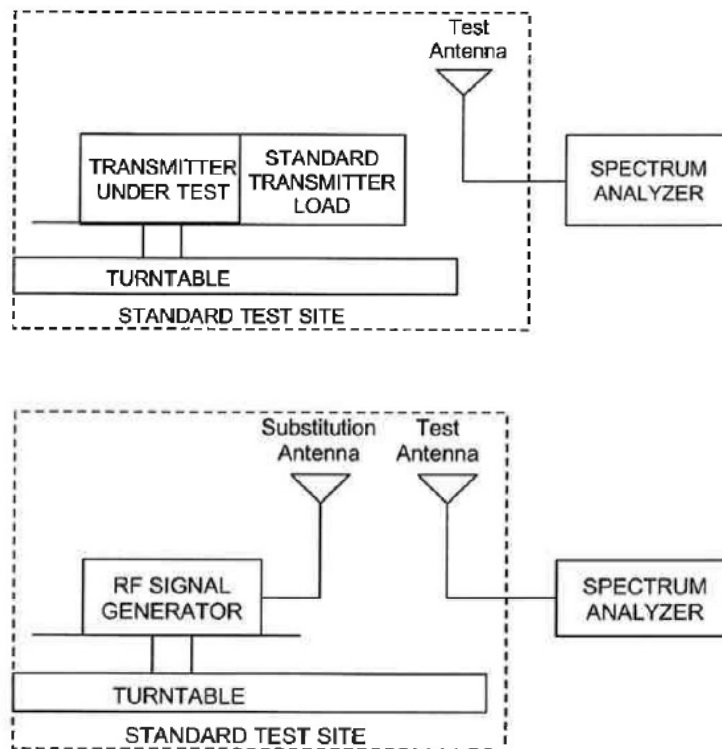

Figure #7.2 Substitution methods TIA/EIA-603-C



12.2 Limit

§90.210 Emission masks / RSS-GEN sec. 4.9; RSS-131 sec. 6.4

Frequency band (MHz)	Mask for equipment with Audio low pass filter	Mask for equipment without audio low pass filter
806–809/851–854	B	H
809–824/854–869	B	G

(g) *Emission Mask G.* For transmitters that are not equipped with an audio low-pass filter, the power of any emission must be attenuated below the unmodulated carrier power (P) as follows:

(2) On any frequency removed from the center of the authorized bandwidth by more than 250 percent of the authorized bandwidth: At least 43 + 10 log (P) dB.

(h) *Emission Mask H.* For transmitters that are not equipped with an audio low-pass filter, the power of any emission must be attenuated below the unmodulated carrier power (P) as follows:

(5) On any frequency removed from the center of the authorized bandwidth by more than 25 kHz: At least 43 + log (P) dB.

$$x[dBm] = P[dBm] - (43 + 10 \log(P[W]))$$

$$x[dBm] = P[dBm] - (43 + 10 \log(\frac{P[mW]}{1000}))$$

$$x[dBm] = P[dBm] - (43 + P[dBm] - 30)$$

$$x[dBm] = -13$$

The Emission limit is -13dBm

§ 90.691 Emission mask requirements for EA-based systems.

(a) Out-of-band emission requirement shall apply only to the “outer” channels included in an EA license and to spectrum adjacent to interior channels used by incumbent licensees. The emission limits are as follows:

(1) For any frequency removed from the EA licensee's frequency block by up to and including 37.5 kHz, the power of any emission shall be attenuated below the transmitter power (P) in watts by at least 116 Log₁₀ (f/6.1) decibels or 50 + 10 Log₁₀ (P) decibels or 80 decibels, whichever is the lesser attenuation, where f is the frequency removed from the center of the outer channel in the block in kilohertz and where f is greater than 12.5 kHz.

(2) For any frequency removed from the EA licensee's frequency block greater than 37.5 kHz, the power of any emission shall be attenuated below the transmitter power (P) in watts by at least 43 + 10Log₁₀ (P) decibels or 80 decibels, whichever is the lesser attenuation, where f is the frequency removed from the center of the outer channel in the block in kilohertz and where f is greater than 37.5 kHz.

(b) When an emission outside of the authorized bandwidth causes harmful interference, the Commission may, at its discretion, require greater attenuation than specified in this section.

$$x[dBm] = P[dBm] - (50 + 10 \log(P[W]))$$

$$x[dBm] = P[dBm] - (50 + 10 \log(\frac{P[mW]}{1000}))$$

$$x[dBm] = P[dBm] - (50 + P[dBm] - 30)$$

$$x[dBm] = -20$$

The worst-case emission limit is -20 dBm. In the range out of the licensee's frequency block up to 14.04 kHz the emission limit is higher than -20 dBm. (f = 12.5 kHz => limit = -7.14 dBm; f = 14.04 kHz => Limit = -20 dBm, see next page)

Test Report No.: 13-048

FCC ID: XS5-U7885L1719P

IC ID: 2237E-U7885L1719P



**BUREAU
VERITAS**

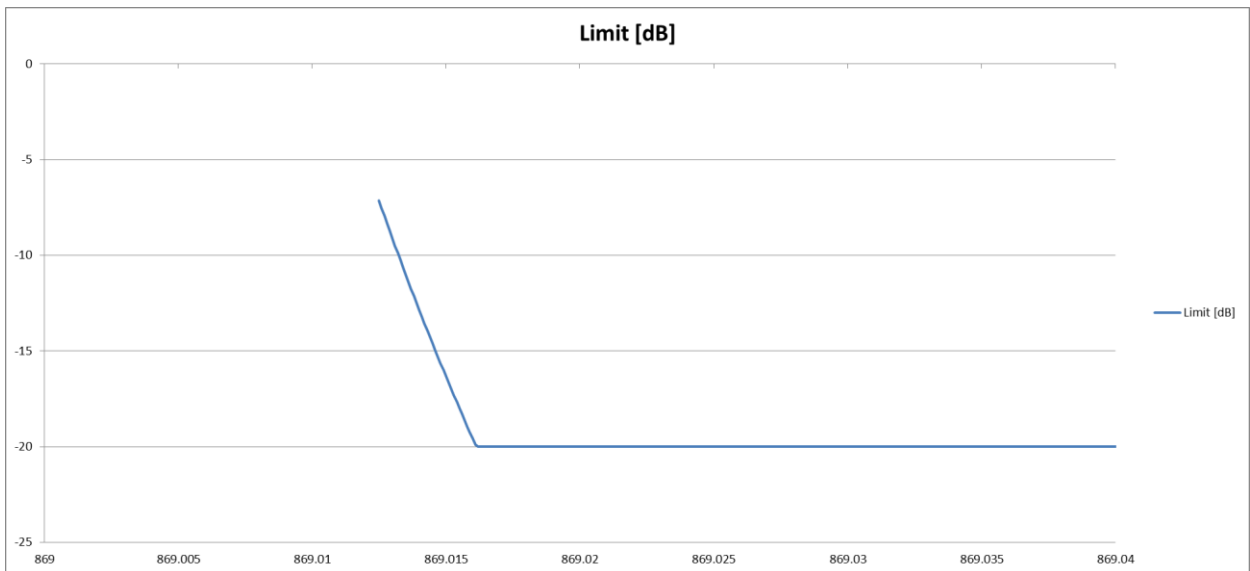
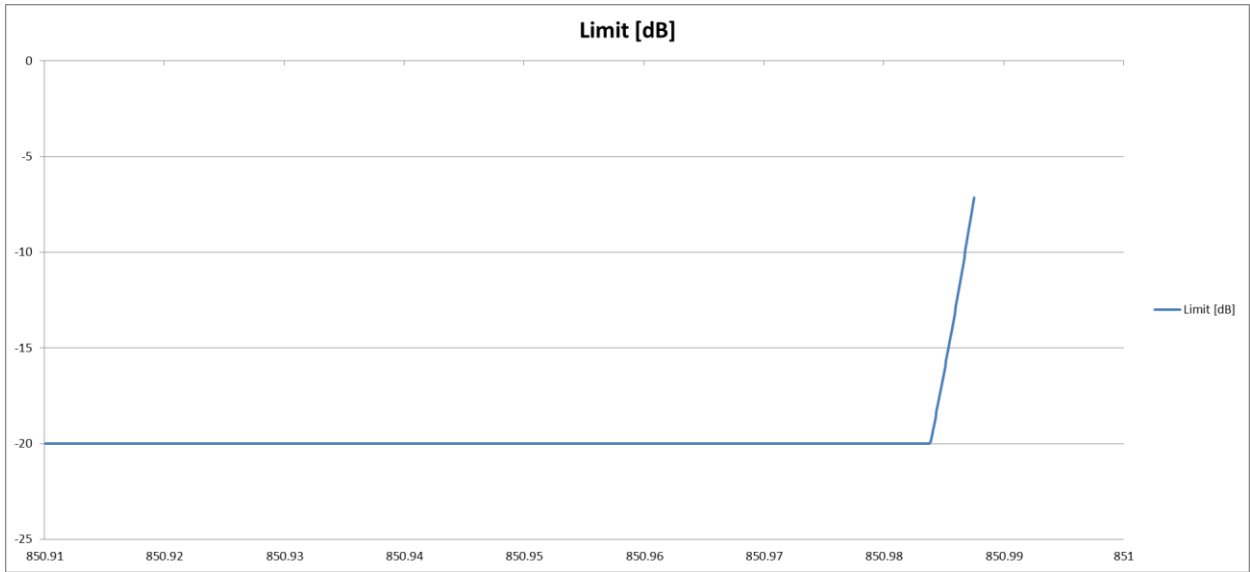

Test Report No.: 13-048

FCC ID: XS5-U7885L1719P

IC ID: 2237E-U7885L1719P



BUREAU
VERITAS

12.3 Receiver Settings

	up to 1 GHz	above 1 GHz
Measurement bandwidth	120 kHz	1 MHz
Step width	60 kHz	500 kHz
Dwell time	20ms	
Detector	Peak (max hold over 360°)	Peak (max hold over 360°)

12.4 Climatic values in the lab

Temperature: 21°
Relative Humidity: 47%
Air-pressure: 998 hPa

Test Report No.: 13-048

FCC ID: XS5-U7885L1719P

IC ID: 2237E-U7885L1719P



BUREAU
VERITAS

12.5 Test results

12.5.1.1 30 MHz to 1 GHz Downlink (Bottom – Middle – Top)

F1: 858.5 MHz; F2: 863.75 MHz; F3: 869 MHz

Vertikal / Horizontal

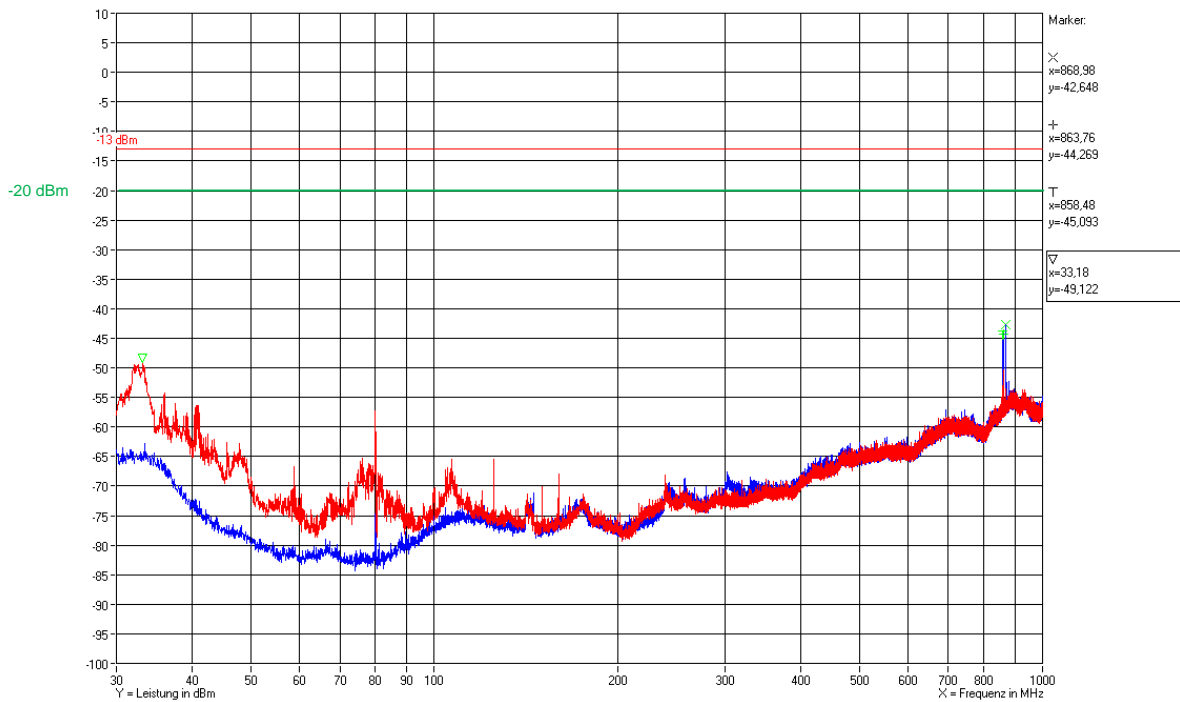

Test Report No.: 13-048

FCC ID: XS5-U7885L1719P

IC ID: 2237E-U7885L1719P



BUREAU
VERITAS

12.5.1.2 30 MHz to 1 GHz Downlink (middle of all path)

F1: 751.5 MHz; F2: 737 MHz; F3: 863.75 MHz; F4: 1962.5 MHz; F5: 2132.5 MHz

Vertikal / Horizontal

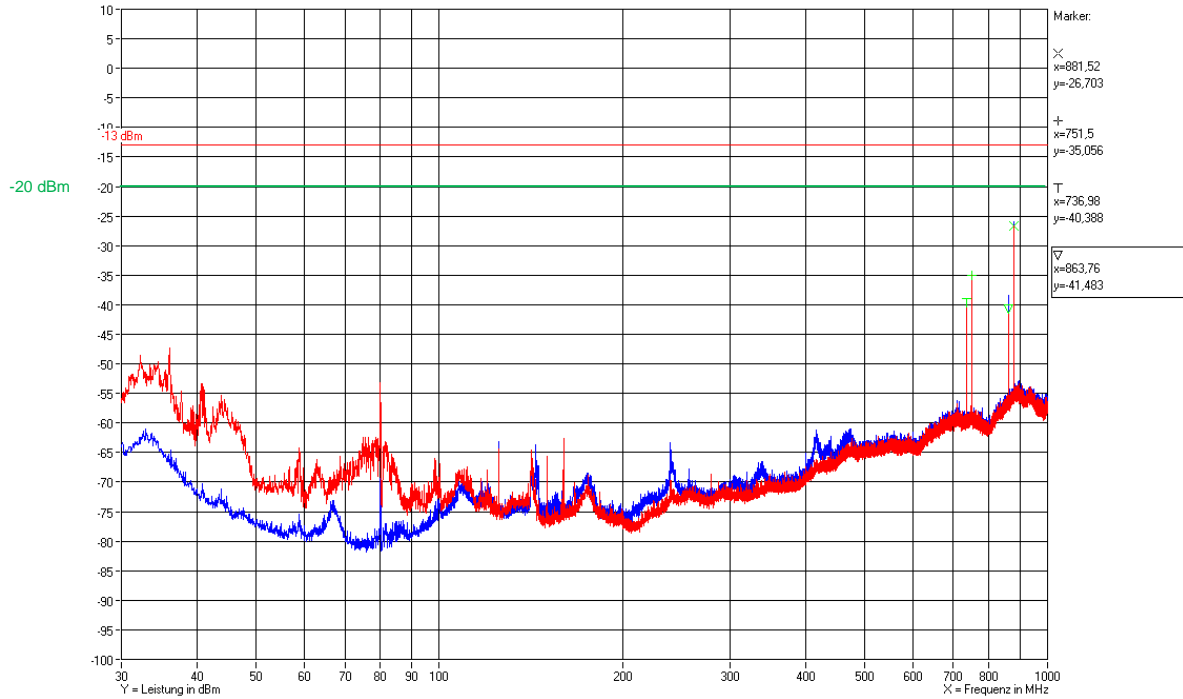

Test Report No.: 13-048

FCC ID: XS5-U7885L1719P

IC ID: 2237E-U7885L1719P



BUREAU
VERITAS

12.5.1.3 1 GHz to 22 GHz Downlink (Bottom – Middle – Top)

F1: 858.5 MHz; F2: 863.75 MHz; F3: 869 MHz

Vertikal / Horizontal

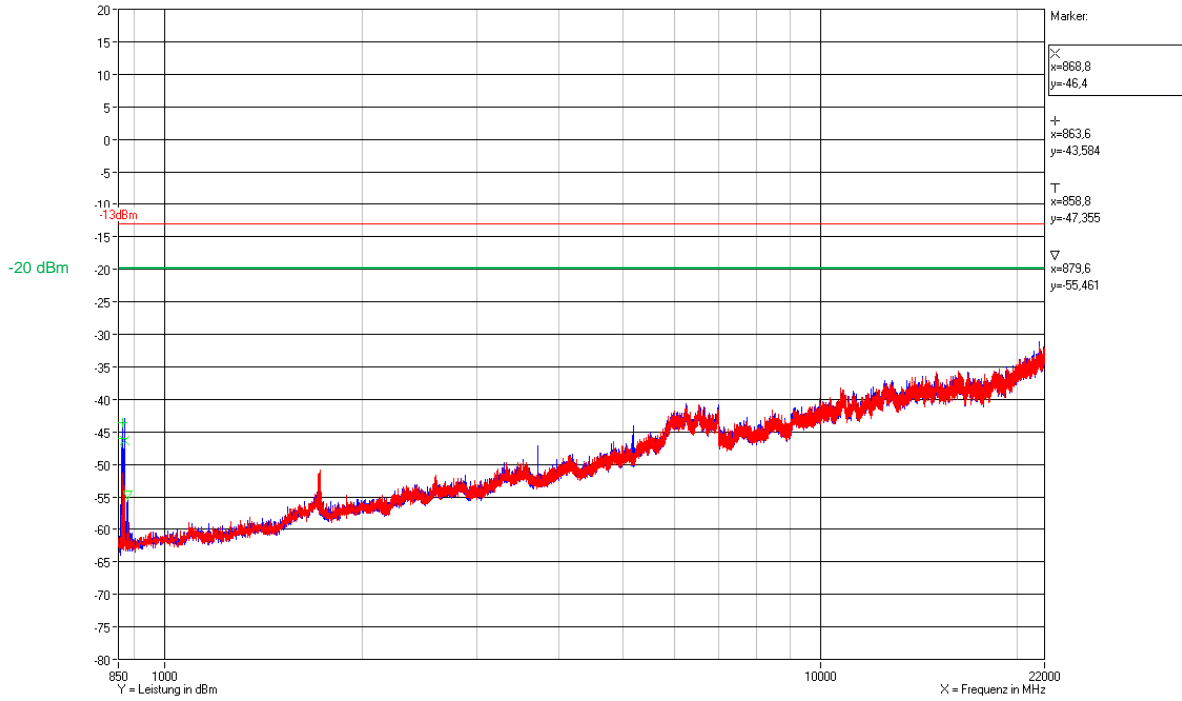

Test Report No.: 13-048

FCC ID: XS5-U7885L1719P

IC ID: 2237E-U7885L1719P



BUREAU
VERITAS

12.5.1.4 1 GHz to 22 GHz Downlink (Bottom – Middle – Top)

F1: 751.5 MHz; F2: 737 MHz; F3: 863.75 MHz; F4: 1962.5 MHz; F5: 2132.5 MHz

Vertikal / Horizontal

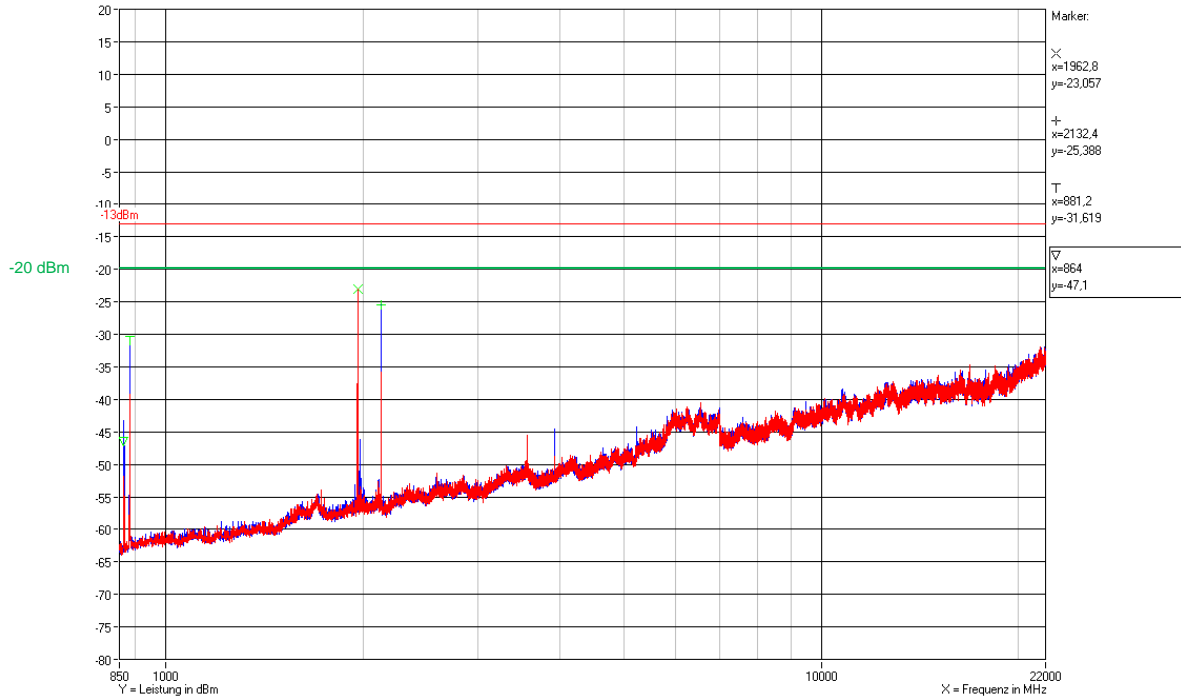

The radiated spurious emission measurements have been passed!

Test Report No.: 13-048

FCC ID: XS5-U7885L1719P

IC ID: 2237E-U7885L1719P



**BUREAU
VERITAS**

13 History

Revision	Modification	Date	Name
01.00	Initial report	26.02.2013	Zahlmann
02.00	put in explanation about limits on page 24, 25, 45 and 46; The system diagram of the EUT on page 8 was deleted	25.06.2013	Zahlmann

******* End of test report *******