

Test Site:
FCC Test Site No.: 96997
IC OATS No.: IC3475A-1



BUREAU
VERITAS

ECL-EMC Test Report No.: 14-197

Equipment under test: TFAH-ES70/80/50 700MHz Path
FCC ID: XS5-TFAHES7850

Type of test: **FCC 47 CFR Part 90 Subpart R: 2014**
 Private Land Mobile Repeater

Measurement Procedures: 47 CFR Parts 2: 2014 (*Frequency Allocations and Radio Treaty Matters; General Rules and Regulations*), Part 27: 2014 (*Miscellaneous Wireless Communication Services*), ANSI/TIA-603-C:2004, *Land Mobile FM or PM Communications Equipment Measurement and Performance Standards*

Test result: **Passed**

Date of issue:	20.10.14		Signature:
Issue-No.:	01	Author:	
Date of delivery:	11.08.14	Checked:	
Test dates:	17.02. – 12.08.14		
Pages:	36		



Manufacturer: ANDREW Wireless Systems GmbH
Industriering 10

D-86675 Buchdorf

Tel.: +49 (0)9099 69 0

Fax: +49 (0)9099 69 140

Test Location: Bureau Veritas Consumer Products Services
Germany GmbH

European Compliance Laboratory (ECL)

Thurn-und-Taxis-Straße 18

D-90411 Nürnberg

Tel.: +49 40 74041 0

Fax: +49 40 74041-2755

General:

The purpose of this report is to show compliance to the FCC regulations for devices operating under Part 27 of the Code of Federal Regulations title 47.

This report informs about the results of the EMC tests, it only refers to the equipment under test. No part of this report may be reproduced in any form, without written permission.



Table of contents

1	TEST RESULTS SUMMARY	5
2	EQUIPMENT UNDER TEST (E.U.T.)	6
2.1	DESCRIPTION	6
2.1.1	DOWNLINK	6
2.1.2	UPLINK	6
2.1.3	DESCRIPTION OF EUT	6
2.1.4	BLOCK DIAGRAM OF MEASUREMENT REFERENCE POINTS	7
2.1.5	DOWNLINK SYSTEM GAIN AND OUTPUT POWER	7
3	TEST SITE (ANDREW BUCHDORF)	8
3.1	TEST ENVIRONMENT	8
3.2	TEST EQUIPMENT	8
3.3	INPUT AND OUTPUT LOSSES	9
3.4	MEASUREMENT UNCERTAINTY	9
4	TEST SITE (BUREAU VERITAS CONSUMER PRODUCTS SERVICES)	10
5	RF POWER OUT: §90.635, §2.1046	11
5.1	LIMIT	11
5.2	TEST METHOD	11
5.3	TEST RESULTS	12
5.3.1	DOWNLINK	12
5.3.1.1	LTE 758 – 768MHz	13
5.3.2	UPLINK	14
5.4	SUMMARY TEST RESULT	14
6	OCCUPIED BANDWIDTH: §90.210, §2.1049	15
6.1	LIMIT	15
6.2	TEST METHOD	15
6.3	TEST RESULTS	15
6.3.1	DOWNLINK	15
6.3.1.1	LTE 758 – 768MHz	16
6.3.2	UPLINK	17
6.4	SUMMARY TEST RESULT	17
7	SPURIOUS EMISSIONS AT ANTENNA TERMINALS: §90.543, §2.1051	18
7.1	LIMIT	18
7.2	TEST METHOD	18
7.3	TEST RESULTS	19
7.3.1	DOWNLINK	19
7.3.1.1	LTE < 1MHz to band edge; 758 – 768MHz	21
7.3.1.2	LTE > 1MHz to band edge 758 – 768MHz	22
7.3.1.3	Measurement in the band of 1559 MHz – 1610 MHz acc. to 27.53(f)	23
7.3.2	UPLINK	23



7.4	SUMMARY TEST RESULT	23
8	OUT OF BAND REJECTION	24
8.1	LIMIT	24
8.2	TEST METHOD	24
8.3	TEST RESULTS	24
8.3.1	DOWNLINK	25
8.3.2	UPLINK	25
8.4	SUMMARY TEST RESULT	25
9	NOISE FLOOR	26
10	RADIATED SPURIOUS EMISSIONS AT THE ECL (BUREAU VERITAS): §90.543, §2.1053, RSS-GEN, RSS-131	27
10.1	METHOD OF MEASUREMENT	30
10.2	LIMIT	31
10.3	RECEIVER SETTINGS	31
10.4	CLIMATIC VALUES IN THE LAB	31
10.5	TEST RESULTS	32
10.5.1	30 MHZ TO 1 GHZ DOWNLINK (BOTTOM – MIDDLE – TOP) SUBPART H	32
10.5.3	30 MHZ TO 1 GHZ DOWNLINK (MIDDLE OF ALL PATHS)	33
10.5.4	1 GHZ TO 21 GHZ DOWNLINK (BOTTOM – MIDDLE – TOP) SUBPART H	34
10.5.6	1 GHZ TO 22 GHZ DOWNLINK (MIDDLE OF ALL PATHS)	35
11	HISTORY	36



1 Test Results Summary

Name of Test	FCC Para. No.	FCC Method	FCC Spec.	Result
RF Power Output	90.635	2.1046	1000 Watts ERP	Complies
Occupied Bandwidth	90.210	2.1049	Input/Output	Complies
Spurious Emissions at Antenna Terminals	90.543	2.1051	-13dBm	Complies
Radiated Spurious emission	90.543	2.1053 TIA/EA-603	-13dBm E.I.R.P	Complies
Frequency Stability	90.539	2.1055	Must stay in band	NA
Out of Band Rejection	KDB 935210 D02 v02	KDB 935210 D02 v02	KDB 935210 D02 v02	Complies
Noise floor	KDB 935210 D02 v02	KDB 935210 D02 v02	KDB 935210 D02 v02	Complies

Frequency stability is given by: The system gets an electrical analog signal from the BSS which is converted into an analog optical signal, transmitted by the optical links and then reconverted in the Remote Unit into an analog electrical signal. During this process happens no frequency change/modification, so input and output have same frequency what can be seen under clause "Occupied Bandwidth".



2 Equipment under test (E.U.T.)

2.1 Description

Kind of equipment	TFAH-ES70/80/50
Andrew Ident. Number	Id. No. TFAH-ES70/80/50
Serial no.(SN)	10
Revision	00
Software version and ID	n. a.
Type of modulation and Designator	LTE (G7D) <input checked="" type="checkbox"/>
Frequency Translation	F1-F1 <input checked="" type="checkbox"/>
	F1-F2 <input type="checkbox"/>
	N/A <input type="checkbox"/>
Band Selection	Software <input type="checkbox"/>
	Duplexer <input checked="" type="checkbox"/>
	Full band <input type="checkbox"/>

2.1.1 Downlink

Full pass band	758 MHz – 775 MHz
Pass band under test	758 MHz – 768 MHz
Max. composite output power based on one carrier (rated)	31 dBm = 1.26 W
Gain*	32 dB

*see 2.1.5

2.1.2 Uplink

Pass band	n. a.
Gain*	n. a.

*see 2.1.5

Note: The EUT does not transmit over the air in the uplink direction.

2.1.3 Description of EUT

TFAH-ES70/80/50 is a multi-band, multi-operator remote unit configuration used in conjunction with a master unit in the ION optical distribution system. This system transports up to three frequency bands simultaneously (500 MHz, 700 MHz, and 800MHz), providing a cost-effective solution for distributing capacity from one or more base stations.

This Test Report describes only the approval of the 700 MHz path (758 – 768 MHz)



2.1.4 Block diagram of measurement reference points

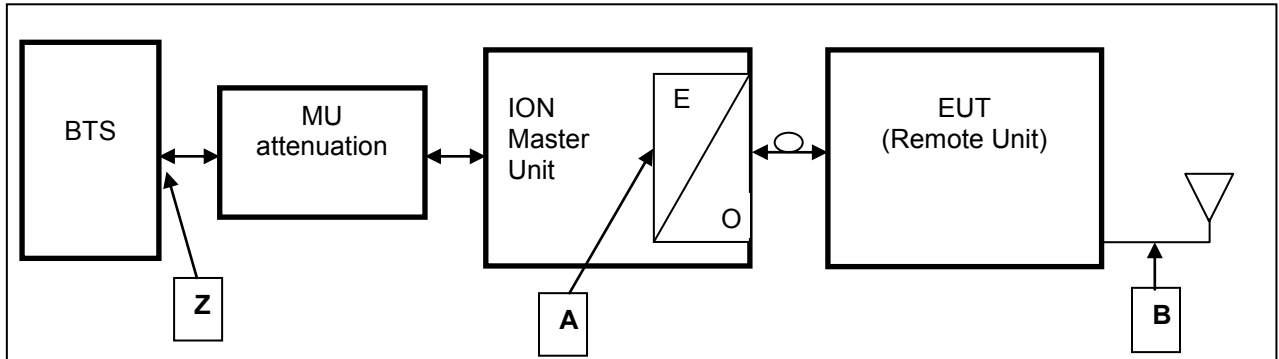

figure 2.1.4-#2 Block diagram of measurement reference points

Remote/Extension Unit is the EUT
 O/E Optical/Electrical converter
 SRMU SubRackMaster Unit

Reference point A, SRMU UL output, DL input
 Reference point B, Remote Unit DL output, UL input
 Reference point Z, BTS DL output, BTS UL input

Since a signal generator does not supply a good output signal with +33 or +43dBm, for the downlink measurement the MU Attenuation is not used. That means for downlink measurements the signal generator is connected to measurement point A at the master optical / electrical converter and the analyzer to the measurement point B at the RU.

2.1.5 Downlink System Gain and Output Power

System optimized for BTS power	MU Attenuation (<i>manual leveling</i>)	Maximum rated input power at the MU OTRX	RU Gain	Maximum rated output power at RU Antenna port
Z		A	A to B	B
+33 dBm	34 dB	-1 dBm	+32 dB	+31.0 dBm @ 1 carrier
System Gain Z to B	-2 dB			
+43 dBm	44 dB	-1 dBm	+32 dB	+31.0 dBm @ 1 carrier
System Gain Z to B	-12 dB			

table 2.1.5-#1 Equipment under test (E.U.T.) Description Downlink System Gain and Output Power



3 Test site (Andrew Buchdorf)

3.1 Test environment

All tests were performed under the following environmental conditions:

Condition	Minimum value	Maximum value
Barometric pressure	86 kPa	106 kPa
Temperature	15°C	30°C
Relative Humidity	20 %	75 %
Power supply range	±5% of rated voltages	

3.2 Test equipment

ANDREW Inv. No.	Test equipment	Type	Manufacturer	Serial No.	Calibration
9102	Network Analyzer	ZVB14	R&S	100118	08/14
9054	Spectrum Analyzer	FSV13	R&S	100859	12/14
9233	Signal Generator	SMBV100A	R&S	257777	06/15
8849	Signal Generator	SMU200A	R&S	101732	04/15
8671	Power Meter	E4418B	Agilent	GB39513094	06/15
8672	Power Sensor	E9300H	Agilent	US41090179	06/15
7306	Circulator	C25E-1FFF	AEROTEK	12580	CIU
7307	Circulator	C25E-1FFF	AEROTEK	12581	CIU
7408	RF-Cable	2,0m; N-N	Andrew	---	CIU
7409	RF-Cable	2,0m; N-N	Andrew	---	CIU
7410	RF-Cable	1,0m; N-N	Andrew	---	CIU
7411	RF-Cable	2,0m; N-N	Andrew	---	CIU
7373	RF-Cable	Multiflex141	Andrew	---	CIU
7374	RF-Cable	Multiflex141	Andrew	---	CIU
7437	RF-Cable	Multiflex141	Andrew	---	CIU
7438	RF-Cable	Multiflex141	Andrew	---	CIU
7439	RF-Cable	Multiflex141	Andrew	---	CIU
7443	RF-Cable	Multiflex141	Andrew	---	CIU
7444	RF-Cable	Multiflex141	Andrew	---	CIU
7445	RF-Cable	Multiflex141	Andrew	---	CIU
7446	RF-Cable	Multiflex141	Andrew	---	CIU
7447	RF-Cable	Multiflex141	Andrew	---	CIU
7448	RF-Cable	Multiflex141	Andrew	---	CIU
7449	RF-Cable	Multiflex141	Andrew	---	CIU
7450	RF-Cable	Multiflex141	Andrew	---	CIU
7440	RF-Cable	RG-223 0.8m	Andrew	---	CIU
7441	RF-Cable	RG-223 0.8m	Andrew	---	CIU
7453	RF-Cable	RG223 2m SMA.	Andrew	---	CIU
7454	RF-Cable	RG223 2m SMA.	Andrew	---	CIU
7455	RF-Cable	RG223 2m SMA.	Andrew	---	CIU
7144	Attenuator	2N-20dB	Inmet 64671	---	CIU
7341	Power Attenuator	768-20	Narda	---	CIU
7368	Matrix		COMMSCOPE	---	weekly

CIU = Calibrate in use



3.3 Input and output losses

All recorded power levels should be referenced to the input and output connectors of the repeater, unless explicitly stated otherwise.

The test equipment used in this test has to be calibrated, so that the functionality is also checked.

All cables, attenuators, splitter, isolator, circulator and combiner etc. must be measured before testing and used for compensation during testing.

3.4 Measurement uncertainty

The extended measurement uncertainty corresponds to the measurement results from the standard measurement uncertainty multiplied by the coverage factor $k=2$. The true value is located in the corresponding interval with a probability of 95 %.

Test Report No.: 14-197

FCC ID: XS5-TFAHES7850



BUREAU
VERITAS

4 Test site (Bureau Veritas Consumer Products Services)

FCC Test site: 96997

IC OATS: IC3475A-1

See relevant dates under section 10 of this test report.



5 RF Power Out: §90.635, §2.1046

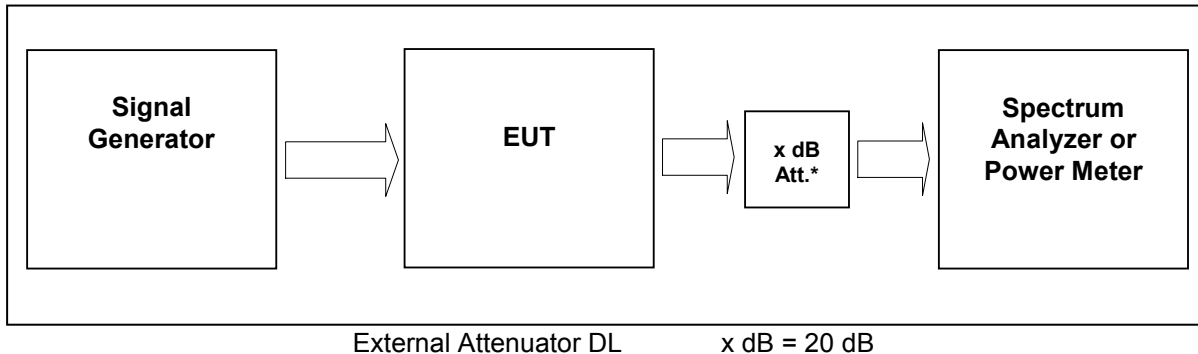

figure 5-#1 Test setup: RF Power Out: §90.635, §2.1046

Measurement uncertainty	± 0,38 dB
Test equipment used	9054, 9233, 7444; 7306; 7144; 7454; 7453; 7341; 7449; 7368

5.1 Limit

Minimum standard:

§90.541 Transmitting power limits.

The transmitting power of base, mobile, portable and control stations operating in the 769-775 MHz and 799-805 MHz frequency bands must not exceed the maximum limits in this section, and must also comply with any applicable effective radiated power limits in §90.545.

(a) The transmitting power of base transmitters must not exceed the limits given in paragraphs (a), (b) and (c) of §90.635.

§ 90.635 Limitations on power and antenna height.

(a) The effective radiated power and antenna height for base stations may not exceed 1 kilowatt (30 dBw) and 304 m. (1,000 ft.) above average terrain (AAT), respectively, or the equivalent thereof as determined from the Table. These are maximum values, and applicants will be required to justify power levels and antenna heights requested.

5.2 Test method

§ 2.1046 Measurements required: RF power output.

(a) For transmitters other than single sideband, independent sideband and controlled carrier radiotelephone, power output shall be measured at the RF output terminals when the transmitter is adjusted in accordance with the tune-up procedure to give the values of current and voltage on the circuit elements specified in § 2.1033(c)(8). The electrical characteristics of the radio frequency load attached to the output terminals when this test is made shall be stated.

(c) For measurements conducted pursuant to paragraphs (a) and (b) of this section, all calculations and methods used by the applicant for determining carrier power or peak envelope power, as appropriate, on the basis of measured power in the radio frequency load attached to the transmitter output terminals shall be shown. Under the test conditions specified, no components of the emission spectrum shall exceed the limits specified in the applicable rule parts as necessary for meeting occupied bandwidth or emission limitations



5.3 Test Results

Detector RMS.

Test signal LTE:

Signal waveform according to Test Model 1.1, E-TM1.1, clause 6.1.1.1-1, table 6.1.1.1-1 of standard specification 3GPP TS 36.141 V9.3.0 (2010-03).

5.3.1 Downlink

Modulation	Measured at	Path	RBW VBW Span	RF Power (dBm)	RF Power (W)	Plot -
LTE	Middle	763.0 MHz	3MHz 10MHz 50MHz	31.0	1.26	5.3.1.1 #1
Maximum output power = 31.0 dBm = 1.26 W						
Limit Maximum output power 60 dBm = 1000 W (erp)						

table 5.3.1-#1 RF Power Out: §90.635, §2.1046 Test Results Downlink

The max RF Power out is 31 dBm, so the maximum antenna gain (x) can be calculated as follow:

Limit = 1000W (erp) = 60 dBm

Info: 1000W (erp) = 1640W (eirp)

$$60 \text{ dBm} > 31 \text{ dBm} + x \quad \text{----->} \quad x = 60 \text{ dBm} - 31 \text{ dBm} = \underline{29 \text{ dBd}}$$

$$x \text{ dBi} = 29 \text{ dBd} + 2.15 = \underline{31.15 \text{ dBi}}$$

=> The antenna that will use for the complete system have to have a gain lower than 31.15 dBi, relative to a dipol.

Modulation	Pin / dBm (Ref. point A)
LTE	-3.5

table 5.3.1-#2 RF Power Out: §90.635, §2.1046 Test Results Downlink Input power



5.3.1.1 LTE 758 – 768MHz

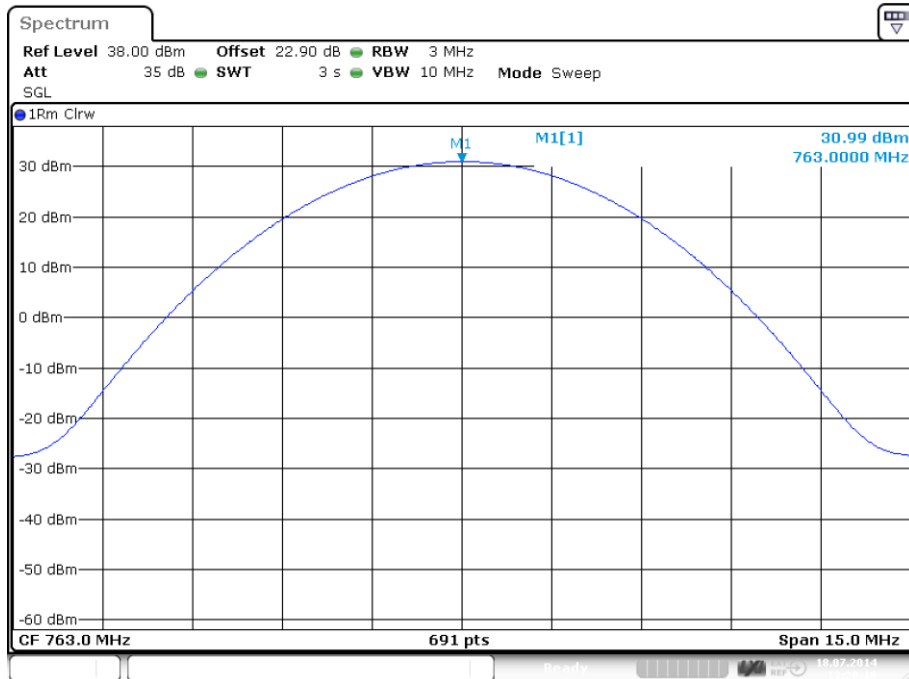

Date: 18.JUL.2014 13:20:11

plot 5.3.1.1-#1 RF Power Out: \$90.635, \$2.1046; Downlink; LTE 758 – 768MHz Middle



5.3.2 Uplink

n.a.

Note: The EUT does not transmit over the air in the uplink direction.

5.4 Summary test result

Test result	complies, according the plots above
Tested by:	M. Leinfelder
Date:	18.07.2014



6 Occupied Bandwidth: §90.210, §2.1049

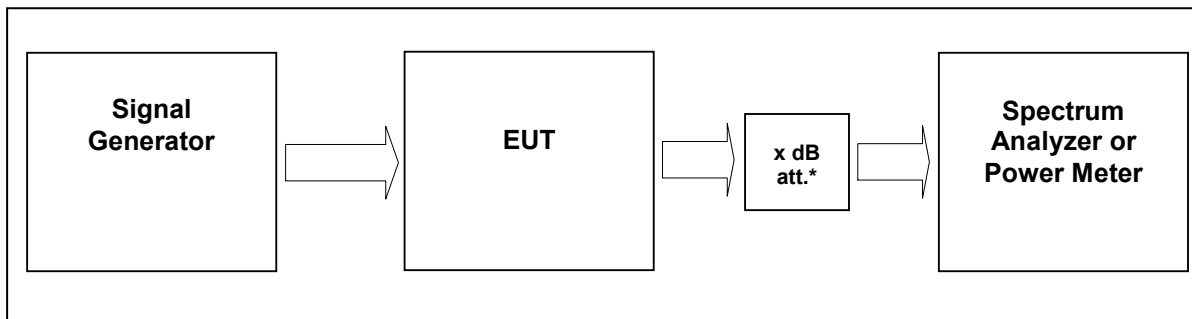

External Attenuator DL x dB = 20 dB
figure 6-#1 Test setup: Occupied Bandwidth: §90.210, §2.1049

Measurement uncertainty	± 0,38 dB
Test equipment used	9054, 9052, 7366, 7367, 7299, 7280, 7363

6.1 Limit

The spectral shape of the output should look similar to input for all modulations.

6.2 Test method

Para. No.2.1049

The occupied bandwidth, that is the frequency bandwidth such that, below its lower and above its upper frequency limits, the mean powers radiated are each equal to 0.5 percent of the total mean power radiated by a given emission shall be measured under the following conditions as applicable:

6.3 Test results

6.3.1 Downlink

Detector RMS.

Modulation	Measured at	Path	RBW VBW Span	Occupied Bandwidth / MHz	Plot #
LTE	Middle	763.0 MHz	30 kHz 300 kHz 5 MHz	1.1	6.3.1.1 #1, #2

table 6.3-#1 Occupied Bandwidth: §90.210, §2.1049 Test results



6.3.1.1 LTE 758 – 768MHz

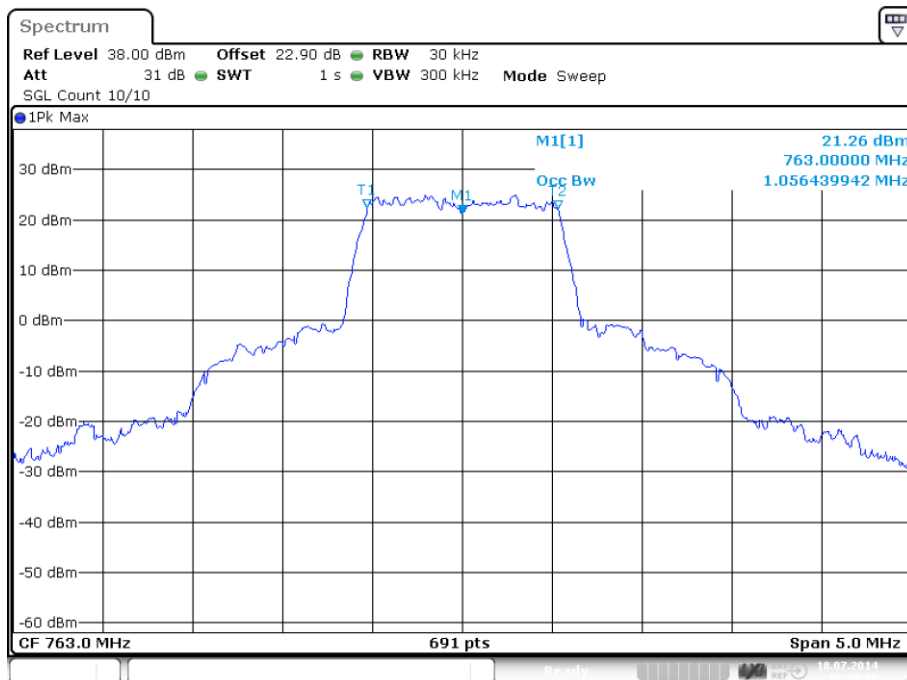

plot 6.3.1.1-#1 Occupied Bandwidth: \$90.210, \$2.1049; Test results; Downlink; LTE 758 – 768MHz Output

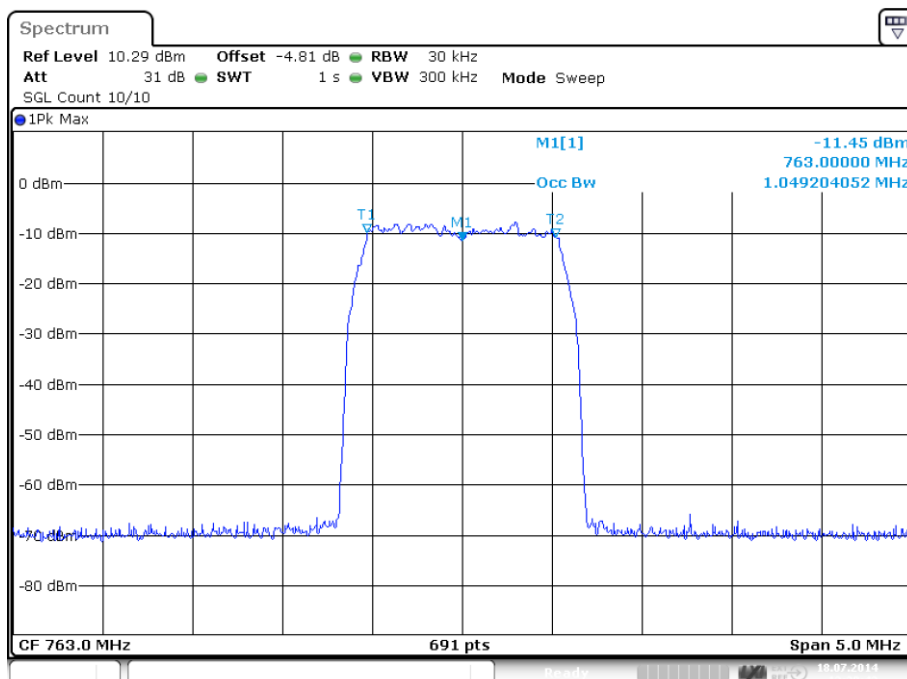

plot 6.3.1.1-#2 Occupied Bandwidth: \$90.210, \$2.1049; Test results; Downlink; LTE 758 – 768MHz Input



6.3.2 Uplink

n.a.

Note: The EUT does not transmit over the air in the uplink direction.

6.4 Summary test result

Test result	complies, according the plots above
Tested by:	M. Leinfelder
Date:	18.07.2014



7 Spurious Emissions at Antenna Terminals: §90.543, §2.1051

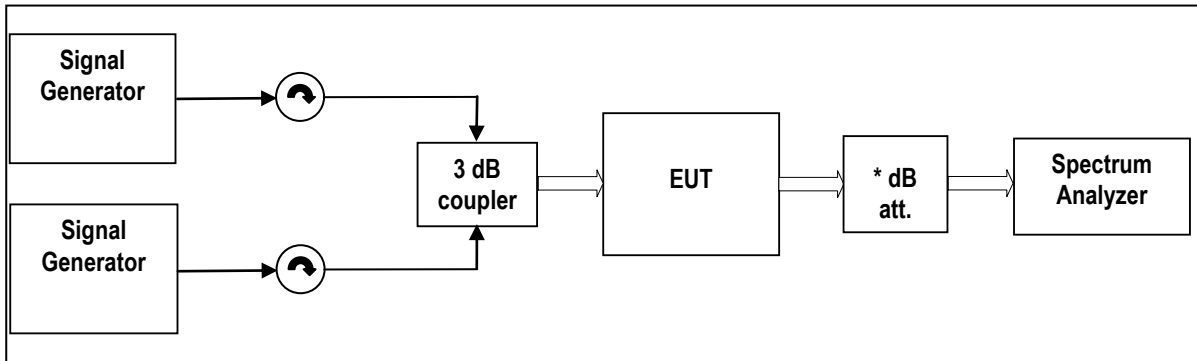

External Attenuator DL x dB = 20 dB

figure 7-#1 Test setup: Spurious Emissions at Antenna Terminals: §90.543, §2.1051

Measurement uncertainty	± 0,54 dB ± 1,2 dB ± 1,5 dB	9 kHz to 3 GHz 3 GHz to 7 GHz 7 GHz to 26 GHz
Test equipment used	9054, 9233, 8849; 7444; 7443; 7306; 7307; 7144; 7454;7453; 7341; 7449; 7368	

7.1 Limit

§ 90.543 Emission limitations.

Transmitters designed to operate in 769–775 MHz and 799–805 MHz frequency bands must meet the emission limitations in paragraphs (a) through (d) of this section. Transmitters operating in 763–768 MHz and 793–798 MHz bands must meet the emission limitations in(e) of this section.

Limit -13dBm

7.2 Test method

Para. No 2.1051 Measurements required: Spurious emissions at antenna terminals.

The radio frequency voltage or powers generated within the equipment and appearing on a spurious frequency shall be checked at the equipment output terminals when properly loaded with a suitable artificial antenna. Curves or equivalent data shall show the magnitude of each harmonic and other spurious emission that can be detected when the equipment is operated under the conditions specified in § 2.1049 as appropriate. The magnitude of spurious emissions which are attenuated more than 20 dB below the permissible value need not be specified.

[39 FR 5919, Feb. 15, 1974. Redesignated and amended at 63 FR 36599, July 7, 1998]



7.3 Test results

7.3.1 Downlink

<1MHz from Band Edge

Detector: RMS.

Modulation	Measured at Band Edge	Carriers	RBW VBW Span	Max. level (dBm)	Plot -
LTE	Lower Edge	758,7 MHz 760,1 MHz	30kHz 300kHz 6MHz	-23.2	7.3.1.1 #1
	Upper Edge	765,9 MHz 767,3 MHz			#2

table 7.3-#1 Spurious Emissions at Antenna Terminals: §90.543, §2.1051 Test results <1MHz from Band

>1MHz from Band Edge

Detector: RMS.

Modulation	Carrier	RBW VBW Span	Max. level (dBm)	Plot -
LTE	763.0 MHz	1MHz 3MHz 30MHz – 8GHz	-29.5	7.3.1.2 #1

table 7.3-#2 Spurious Emissions at Antenna Terminals: §90.543, §2.1051 Test results >1MHz from Band Edge



Calculation of the limit according to §27.53 (c)(3):

On all frequencies between 763–775 MHz and 793–805 MHz, by a factor not less than $76 + 10 \log (P)$ dB in a 6.25 kHz band segment, for base and fixed stations;

$P_{out} = 31\text{dBm} = 1.26 \text{ W}$.

$76 + 10 \cdot \log(20\text{W}/1\text{W}) \text{ dB} = 77 \text{ dB Attenuation} \Rightarrow 31\text{dBm} - 77\text{dB} = -46 \text{ dBm}$ in a 6.25 kHz band segment
Spurious measured in the plot with a RBW of 1MHz so the limit is calculated:

$\Rightarrow -46\text{dBm} / 6,25\text{kHz} + 10 \cdot \log(10\text{kHz}/6,25\text{kHz}) = -43,96\text{dBm} / 10\text{kHz}$
(in the frequency range 763–775 MHz and 793–805 MHz)

maximum measured emission level for frequencies between 763–775 MHz and 793–805 MHz is below
-58 dBm / 10kHz.

Test passed.

Considerations to §27.53 (f):

To see if the standard 27.53(f) were met a calculation of the radiated power is necessary. The modulated carrier in the range of 747-757 MHz is working with maximum power and the frequency range of 1559-1610MHz is measured. For the calculation of the radiated power in this band, it was calculated with a typical antenna gain and typical cable loss.

Used 700 MHz narrow band antennas offer a gain of 0 dBi in the in the frequency range 1559 - 1610 MHz, furthermore an antenna cable with a loss of 2 dB is used.

The measured conducted emissions in the frequency range of 1599 - 1610 MHz are below -48 dBm/MHz (see at plot 7.3.1.3).

Conducted emissions ($< -48 \text{ dBm}$) + antenna gain (0 dBi) - cable loss (0 dB) = radiated emissions ($< -48 \text{ dBm}$) which is below the limit of Part 27.53(f).

Even with an antenna gain of 7 dBi (more than worst case) in the frequency range of 1599 - 1610 MHz, we are still under the limit of Part 27.53(f) with a radiated emission of -41 dBm.

Therefore the emission limit is met.

Test passed.

Plots with test result see

7.3.1.3 Measurement in the band of 1559 MHz – 1610 MHz



7.3.1.1 LTE < 1MHz to band edge; 758 – 768MHz

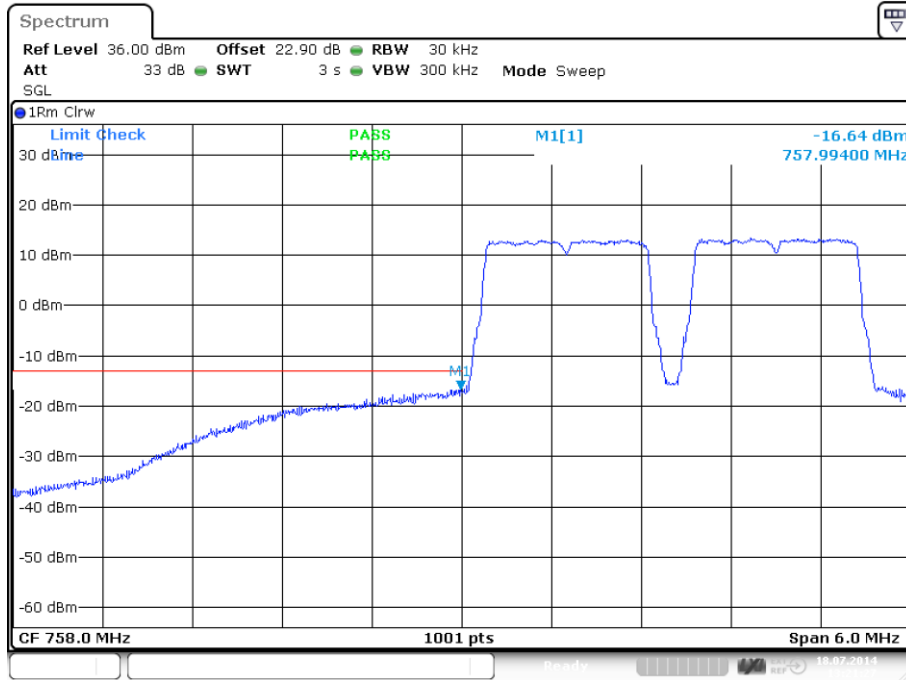

plot 7.3.1.1-#1 Spurious Emissions at Antenna Terminals: §90.543, §2.1051; Test results; Downlink; LTE < 1MHz to band edge; 758 – 768MHz Lower Band Edge

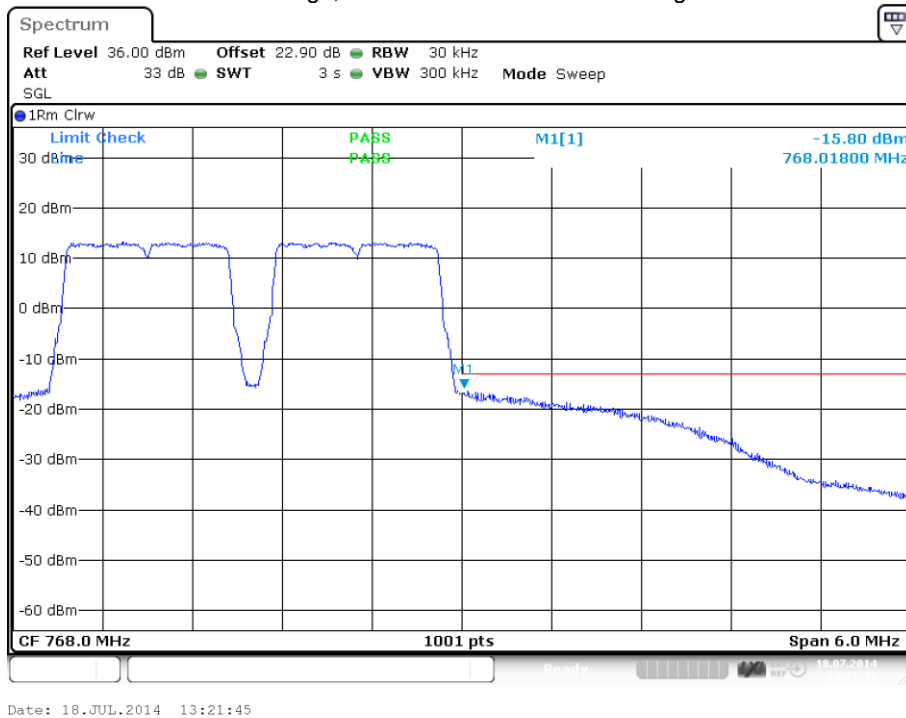

plot 7.3.1.1-#2 Spurious Emissions at Antenna Terminals: §90.543, §2.1051; Test results; Downlink; LTE < 1MHz to band edge; 758 – 768MHz Upper Band Edge



7.3.1.2 LTE > 1MHz to band edge 758 – 768MHz

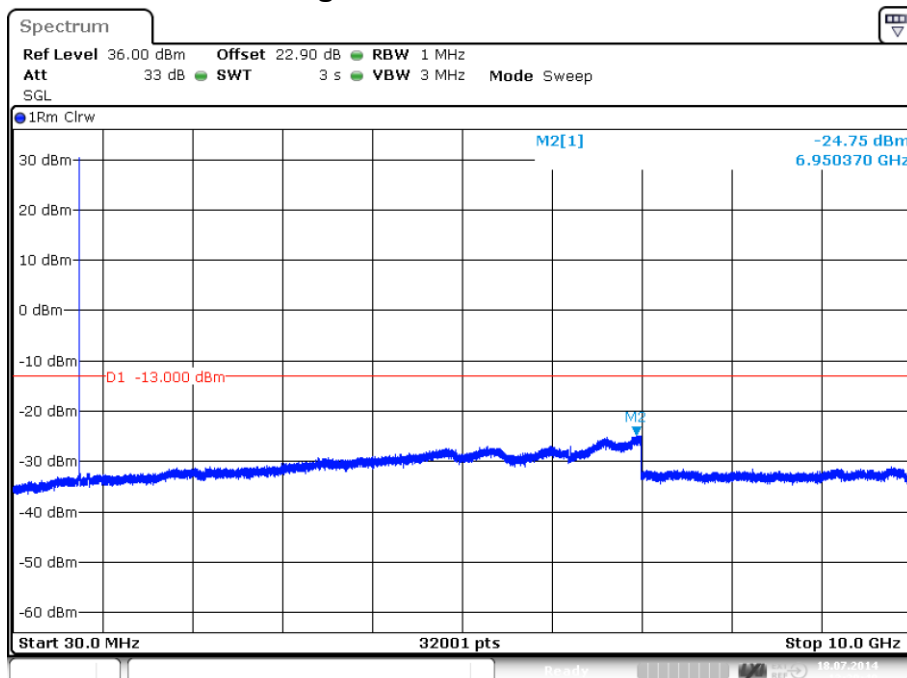

Date: 18.JUL.2014 13:20:50

plot 7.3.1.2-#1 Spurious Emissions at Antenna Terminals: §90.543, §2.1051; Test results; Downlink; LTE > 1MHz to band edge 758 – 768MHz; 30 MHz – 10 GHz

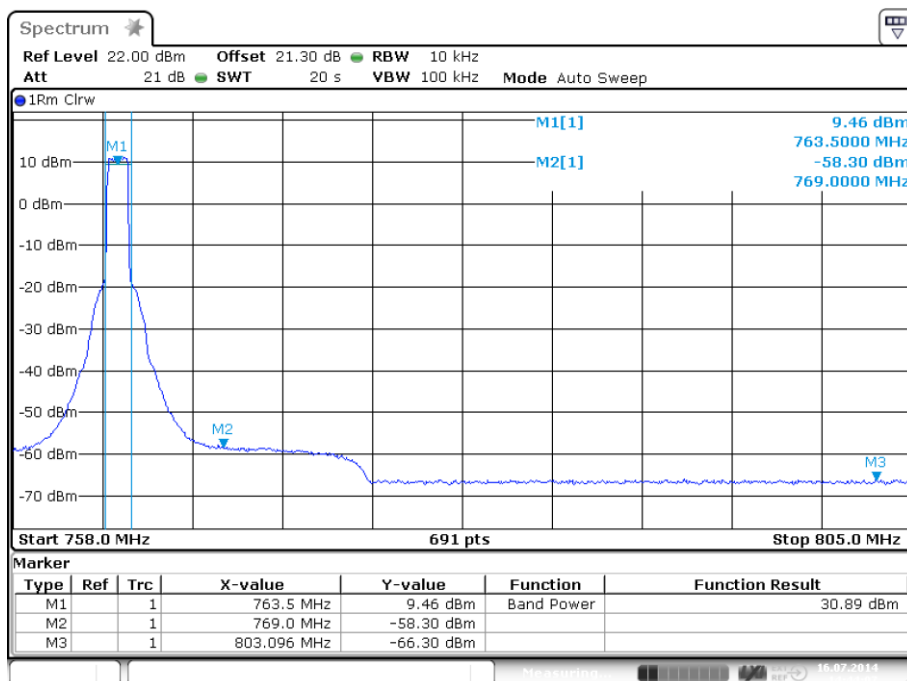

Date: 16.JUL.2014 14:44:07

plot 7.3.1.2-#2 Spurious Emissions at Antenna Terminals: §90.543, §2.1051; Test results; Downlink; LTE > 1MHz to band edge 758 – 768MHz; 763 MHz – 805 MHz



7.3.1.3 Measurement in the band of 1559 MHz – 1610 MHz acc. to 27.53(f)

Calculation see 7.3.1 Test results Downlink

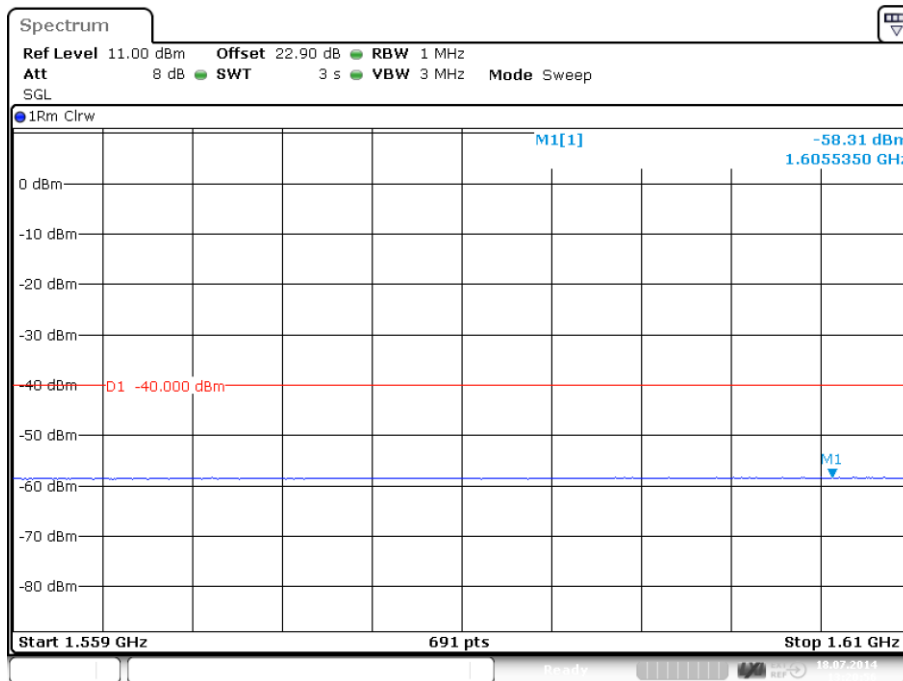

plot 7.3.1.3-#1 Spurious Emissions at Antenna Terminals: §90.543, §2.1051; Test results; Downlink; Measurement in the band of 1559 MHz – 1610 MHz acc. to 27.53(f)

7.3.2 Uplink

n.a.

Note: The EUT does not transmit over the air in the uplink direction.

7.4 Summary test result

Test result	complies, according the plots above
Tested by:	M. Leinfelder
Date:	18.07.2014



8 Out of Band Rejection

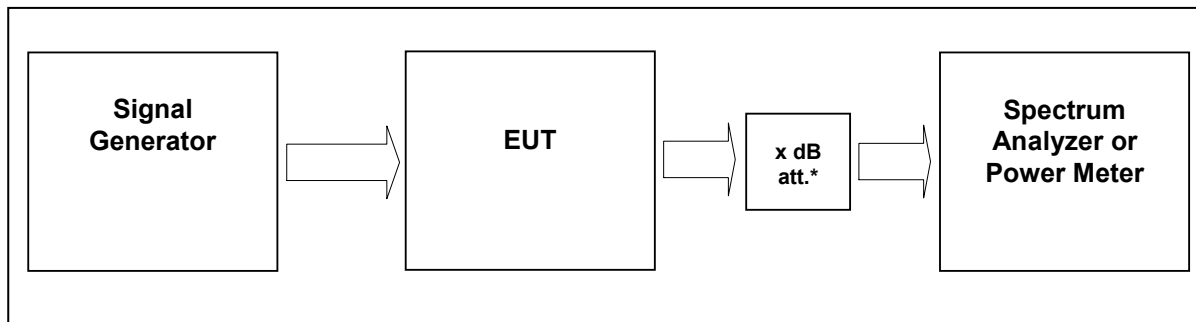

External Attenuator DL x dB = 20 dB
figure 8-#1 Test setup: Out of Band Rejection

Measurement uncertainty	± 0,38 dB
Test equipment used	9054, 9233, 7444; 7306; 7144; 7454; 7453; 7341; 7449

8.1 Limit

KDB 935210 D02 v02

Clause: D.3 POLICIES AND PROCEDURES;

Subclause:

(I) Out of Band Rejection – Test for rejection of out of band signals. Filter frequency response plots are acceptable.

8.2 Test method

KDB 935210 D02 v02

Clause: D.3 POLICIES AND PROCEDURES;

Subclause:

(I) Out of Band Rejection – Test for rejection of out of band signals. Filter frequency response plots are acceptable.

8.3 Test results

Detector Peak max hold



8.3.1 Downlink

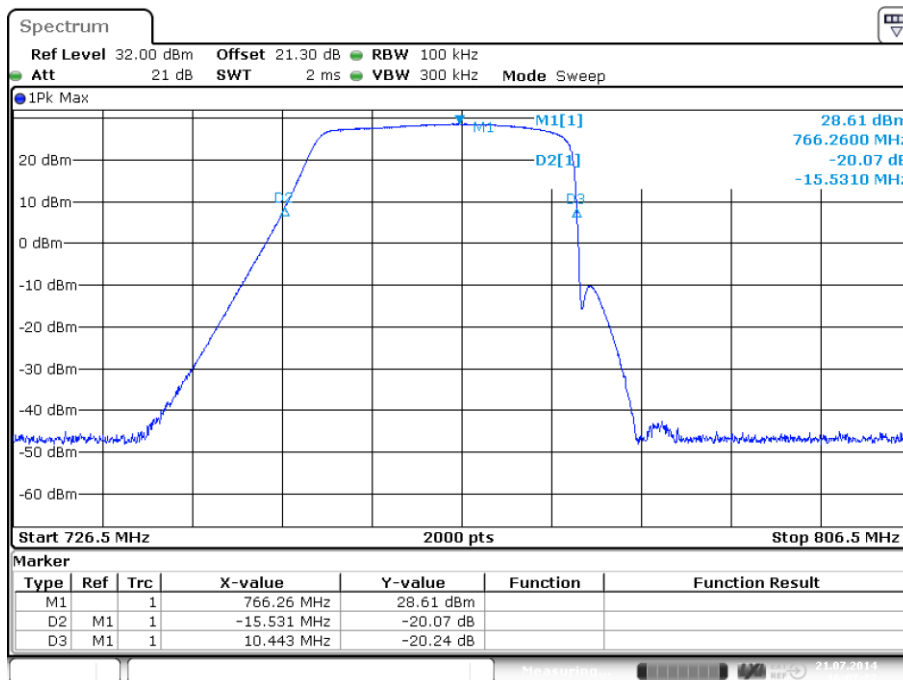

Date: 21.JUL.2014 16:07:22

plot 8.3.1-#1 Out of Band Rejection; Test results; Downlink;

8.3.2 Uplink

n.a.

Note: The EUT does not transmit over the air in the uplink direction.

8.4 Summary test result

Test result	complies, according the plots above
Tested by:	M. Leinfelder
Date:	21.07.2014



9 Noise floor

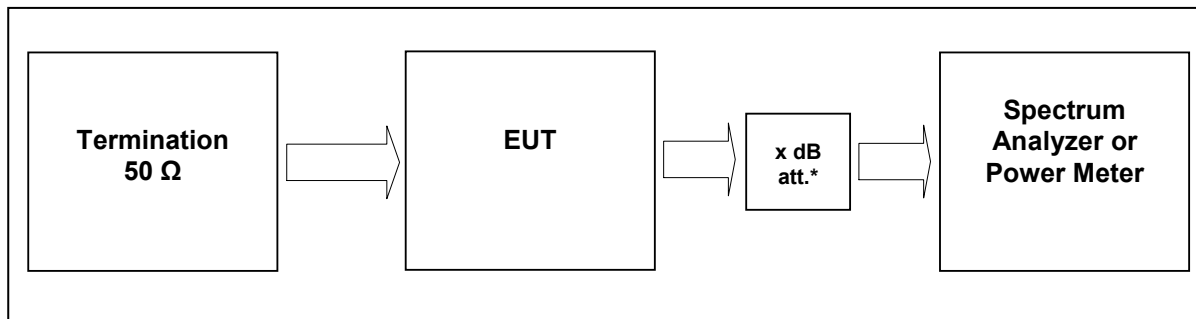

External Attenuator DL x dB = 0 dB
 figure 9-#1 Test setup: Noise floor

Measurement uncertainty	± 0,38 dB
Test equipment used	9054, 7144; 7454; 7453; 7449;

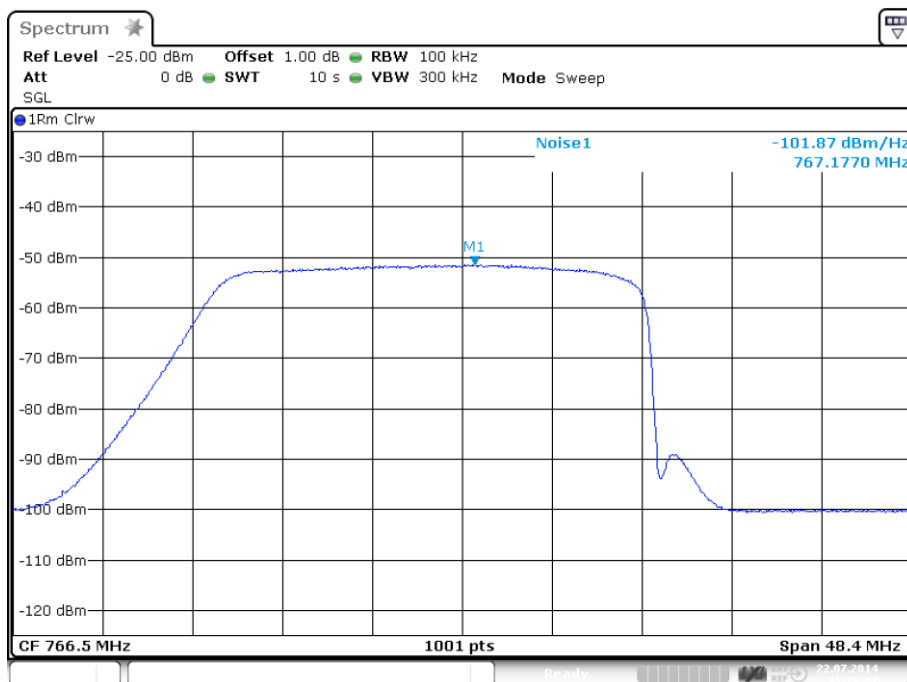

Date: 22.JUL.2014 15:24:07

plot 9-#1 Noise floor;

10 Radiated Spurious Emissions at the ECL (Bureau Veritas): §90.543, §2.1053, RSS-Gen, RSS-131

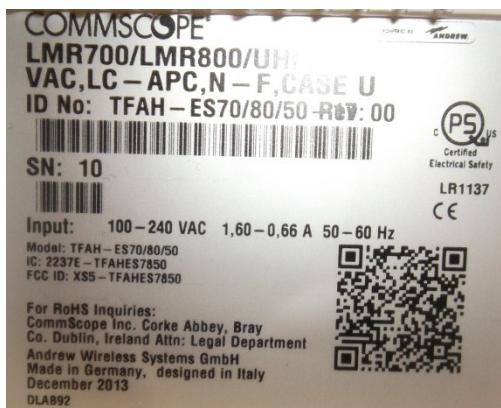

picture 10.1: name plate

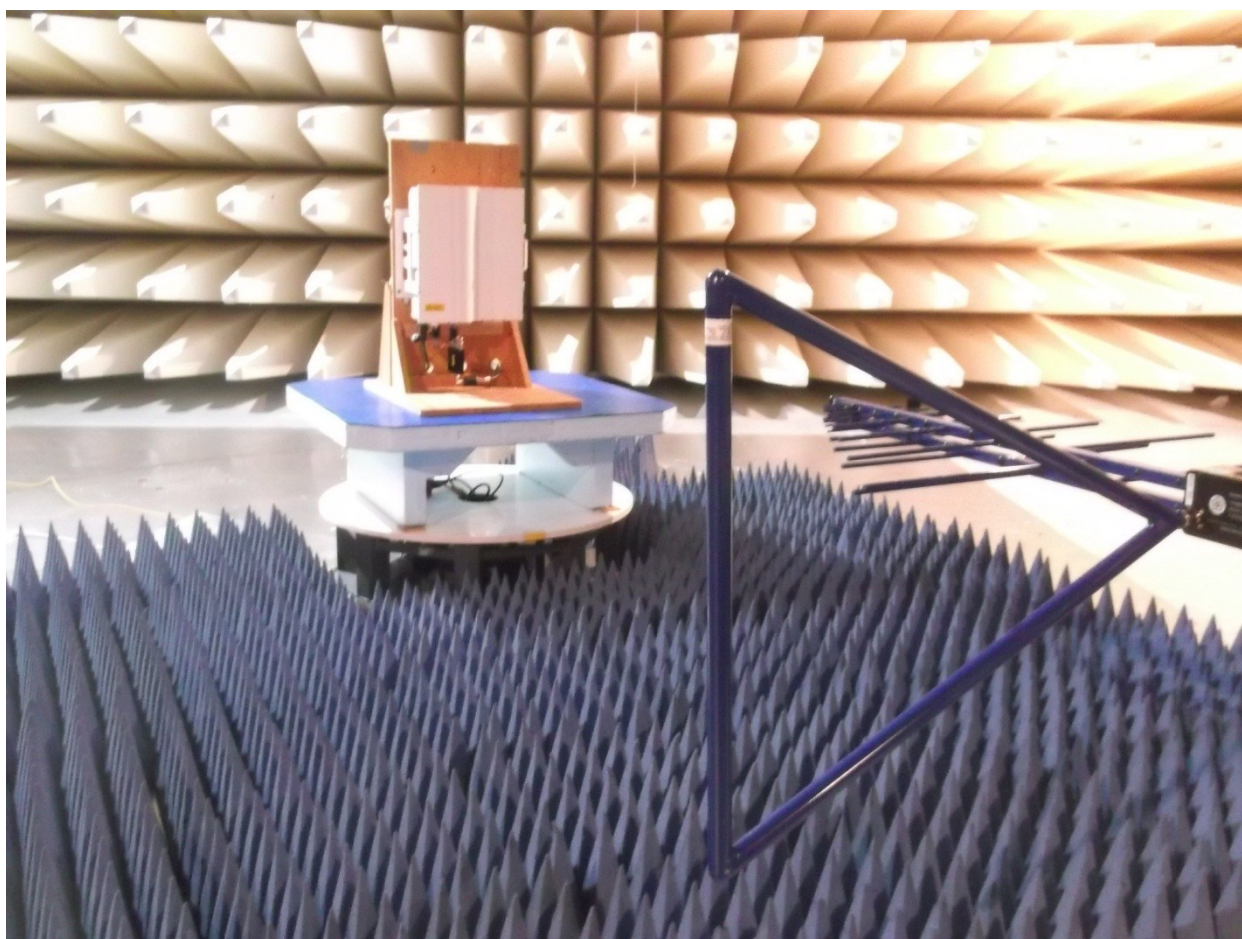

picture 10.2: Test setup: Field Strength Emission <1 GHz @3m in the SAC

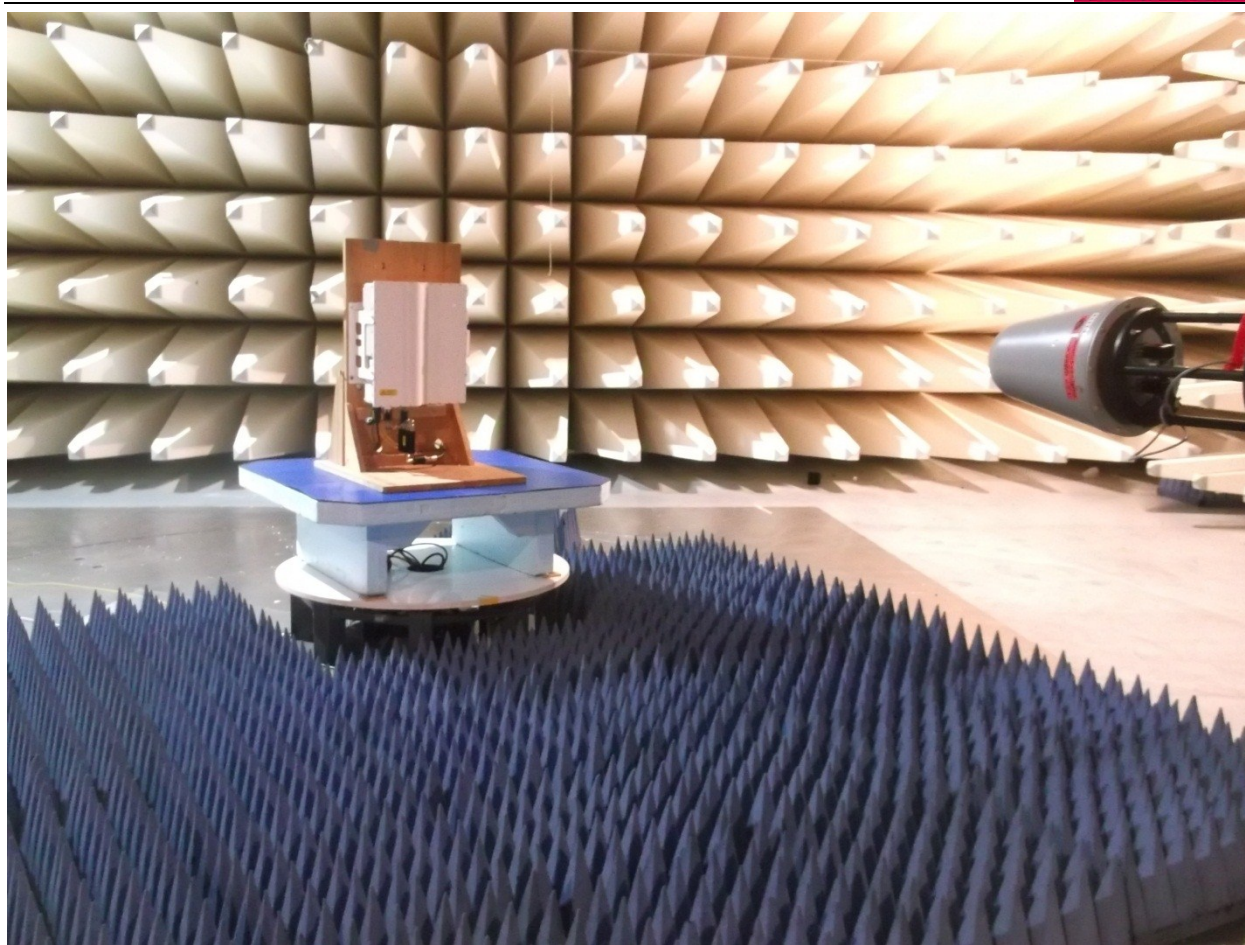

picture 7.3: Test setup: Field Strength Emission >1 GHz @3m in the SAC



This clause specifies requirements for the measurement of radiated emission.

Frequency range	Distance: EUT <-> antenna / location	Limit	Test method
30 MHz - 1 GHz	3 metres / SAC	FCC 47 CFR Part 90.210	TIA/EIA-603-C:2004
1 GHz – 21 GHz	3 metres / SAC		

Test equipment used:

Designation	Type	Manufacturer	Invent.-no.	Cal.-date	due Cal.- date	used
EMI test receiver	ESI40	Rohde & Schwarz	E1687	28.11.2013	28.11.2014	X
Antenna	CBL 6111	Chase	K1026	27.06.2014	27.06.2015	X
Pre amplifier	AM1431	Miteq	K1721	16.04.2014	16.04.2015	X
Antenna	HL 025	R&S	K1114	03.03.2014	03.03.2015	X
Preamplifier	AFS4-00102000	Miteq	K838	03.04.2014	03.04.2015	X
RF Cable	Sucoflex 100	Suhner	K1760	03.07.2014	03.07.2015	X

The REMI version 2.135 has been used for max search.

Test set-up:

Test location: SAC
 Both, the Fully Anechoic Chamber (FAC) and the Semi Anechoic Chamber (SAC) fulfil the requirements of ANSI C63.4 and CISPR 16-1-4 with regards to NSA and SVSWR.

Test Voltage: 115V / 60 Hz
 Type of EUT: Wall mounted

Measurement uncertainty:

Measurement uncertainty expanded (95% or K=2)	± 4,7 dB for ANSI C63.4 measurement ± 0,5 dB for TIA-603 measurement
--	---

10.1 Method of Measurement

Measurement procedure. TIA-603-C

The antenna substitution method is used to determine the equivalent radiated power at spurious frequencies. The spurious emissions are measured at a distance of 3 meters. The EUT is then replaced with a reference substitution antenna with a known gain referenced to a dipole. This antenna is fed with a signal at the spurious frequency. The level of the signal is adjusted to repeat the previously measured level. The resulting eirp is the signal level fed to the reference antenna corrected for gain referenced to an isotropic dipole (see Figure 7.2).

From KDB (AMPLIFIER, BOOSTER, AND REPEATER REMINDER SHEET):

Radiated spurs (enclosure) – Use of CW signal (low, mid, and high freq.) is acceptable rather than all modulations.

The maximum RFI field strength was determined during the measurement by rotating the turntable (± 180 degrees) and varying the height of the receive antenna ($h = 1 \dots 4$ m) as like defined in ANSI C63.4. A measurement receiver has been used with a RBW 120 kHz up to 1 GHz and 1 MHz above 1 GHz. Steps with during pre measurement was half the RBW.

Both, the Fully Anechoic Chamber (FAC) and the Semi Anechoic Chamber (SAC) fulfil the requirements of ANSI C63.4 and CISPR 16-1-4 with regards to NSA and SVSWR.

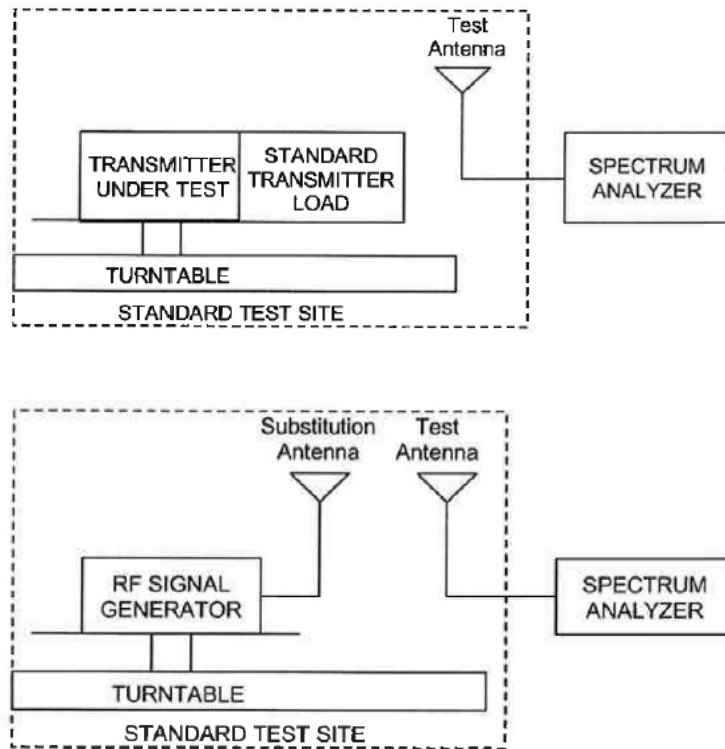

Figure #7.2 Substitution methods TIA/EIA-603-C



10.2 Limit

§ 90.543 Emission limitations.

Transmitters designed to operate in 769–775 MHz and 799–805 MHz frequency bands must meet the emission limitations in paragraphs (a) through (d) of this section. Transmitters operating in 763–768 MHz and 793–798 MHz bands must meet the emission limitations in(e) of this section.

Limit -13dBm

10.3 Receiver Settings

	up to 1 GHz	above 1 GHz
Measurement bandwidth	120 kHz	1 MHz
Step width	60 kHz	500 kHz
Dwell time	20ms	
Detector	Peak	Peak

10.4 Climatic values in the lab

Temperature	22°C
Relative Humidity	43%
Air-pressure	1014 hPa



10.5 Test results

10.5.1 30 MHz to 1 GHz Downlink (Bottom – Middle – Top) Subpart H

Bottom: 758 MHz; Middle: 763 MHz; Top: 768 MHz

Vertikal / Horizontal

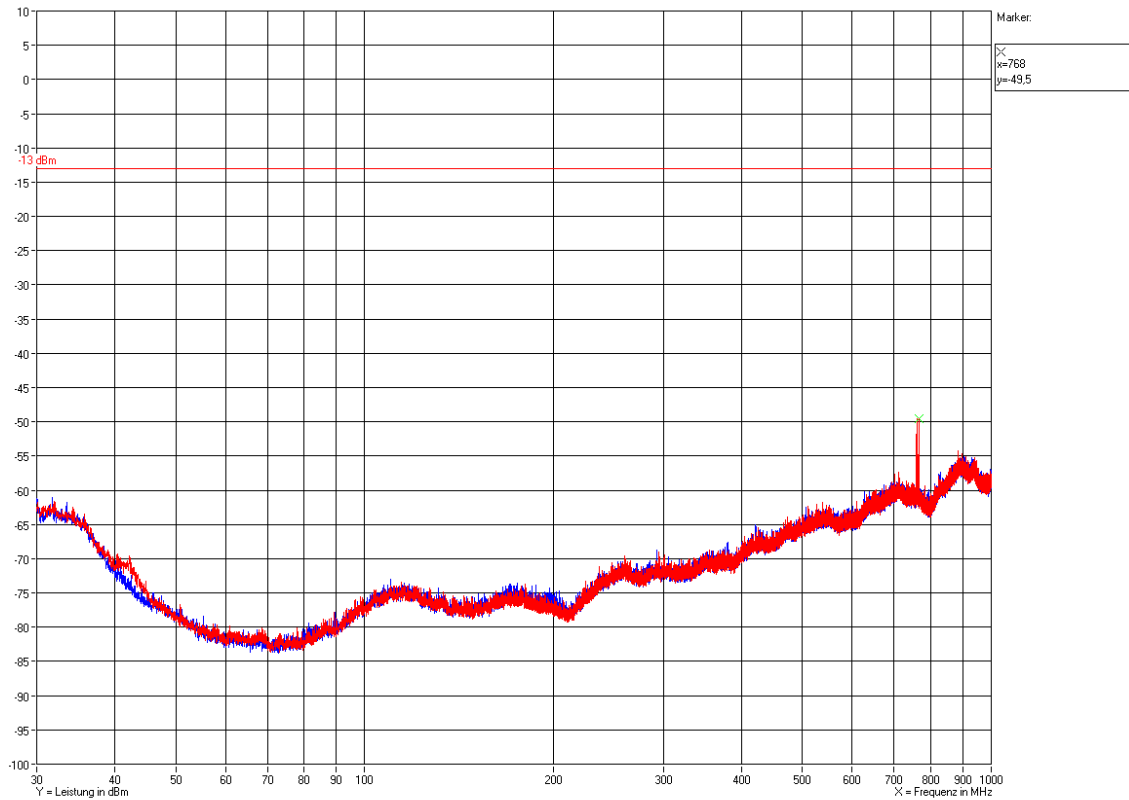



10.5.3 30 MHz to 1 GHz Downlink (Middle of all paths)

F1: 763 MHz; F2: 772 MHz; F3: 856.5 MHz; F4: 865.5 MHz

Vertikal / Horizontal

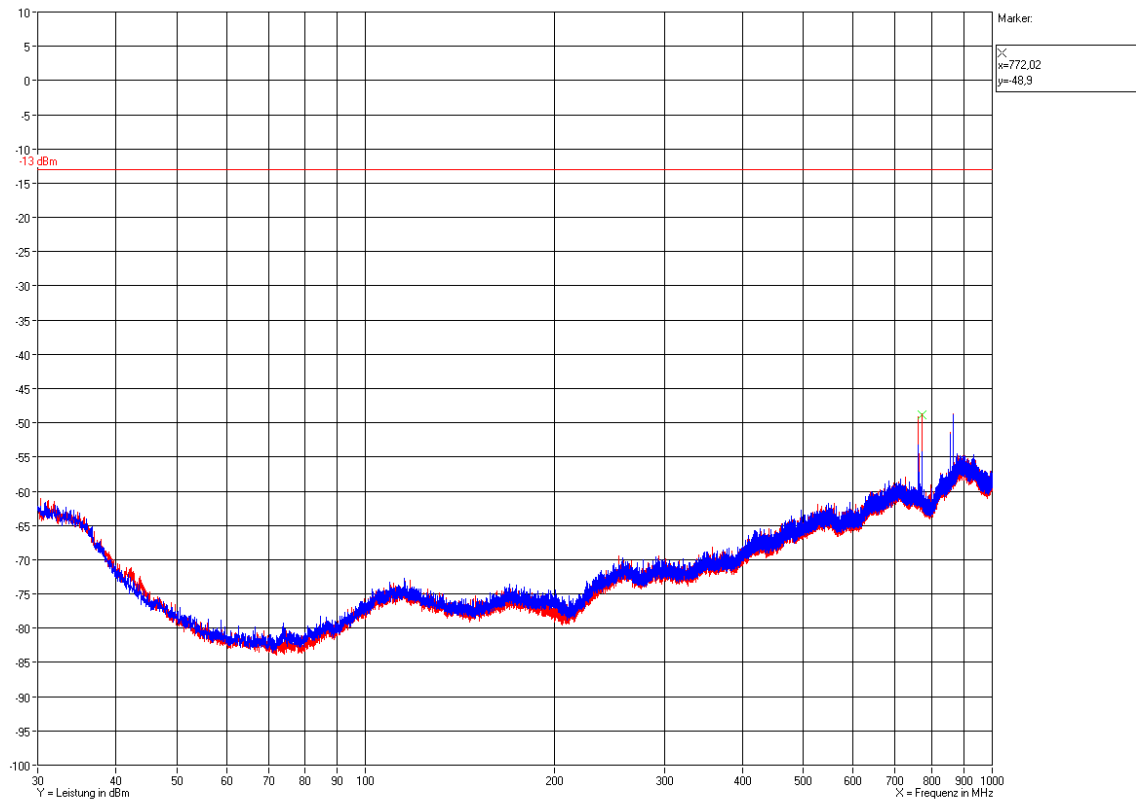



10.5.4 1 GHz to 21 GHz Downlink (Bottom – Middle – Top) Subpart H

Bottom: 758 MHz; Middle: 763 MHz; Top: 768 MHz

Vertikal / Horizontal

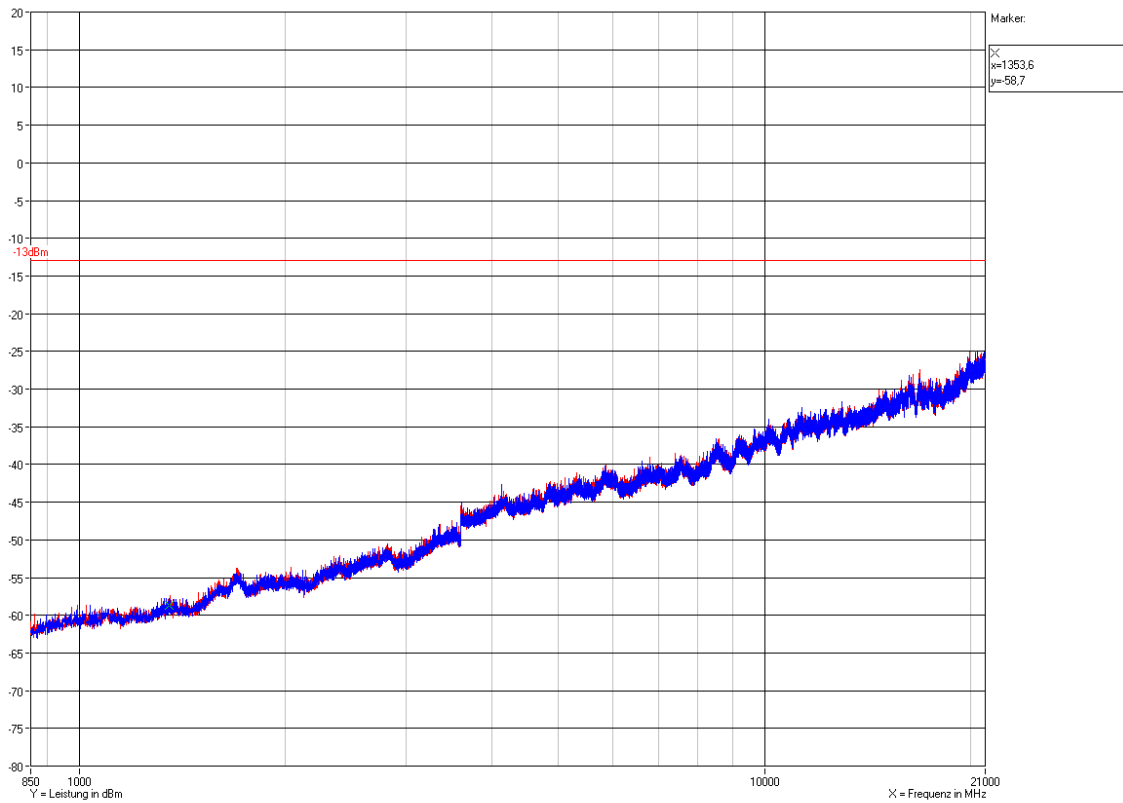



10.5.6 1 GHz to 22 GHz Downlink (Middle of all paths)

F1: 763 MHz; F2: 772 MHz; F3: 856.5 MHz; F4: 865.5 MHz

Vertikal / Horizontal

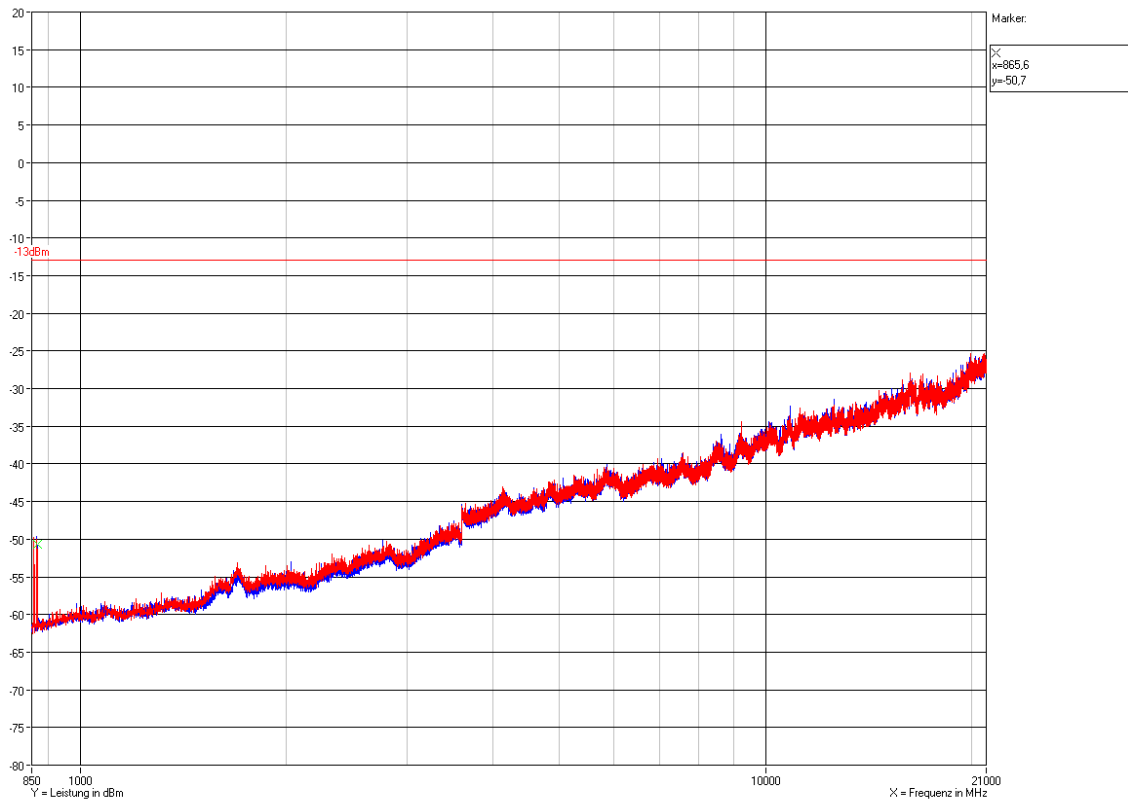

FEK / 12.08.2014

The radiated spurious emission measurements have been passed!



11 History

Revision	Modification	Date	Name
01.00	Initial report	11.09.2014	Zahlmann

******* End of test report *******