

Frequency Band = 806 MHz – 809 MHz, Direction = RF uplink,
Input Power = 0.3 dB < AGC, at **fm** Signal Type = 9K80D7W
(S01_AA01)

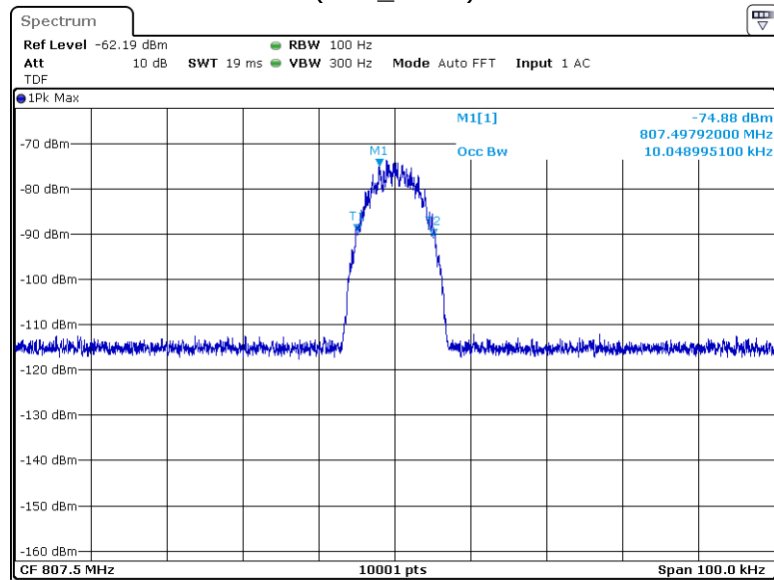

Input Signal

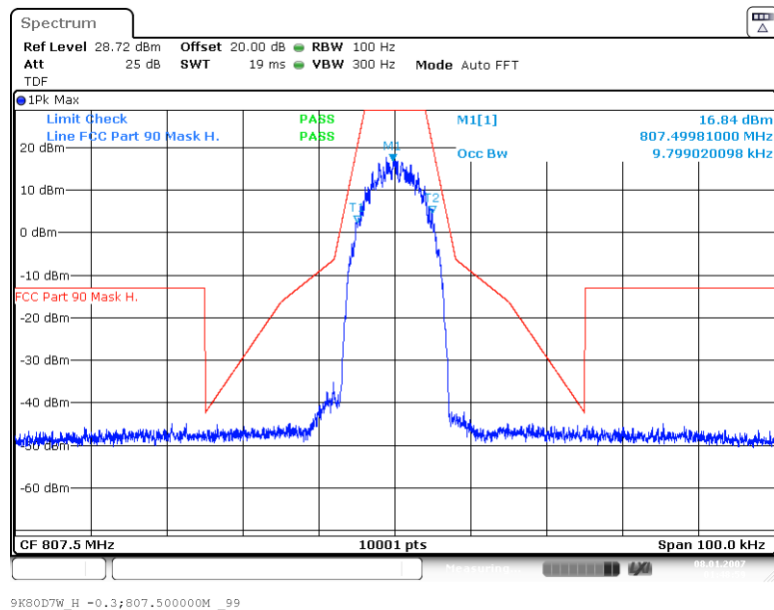

Output Signal

Frequency Band = 806 MHz – 809 MHz, Direction = RF uplink,
Input Power = 3 dB > AGC, at **fm** Signal Type = 9K80D7W
(S01_AA01)

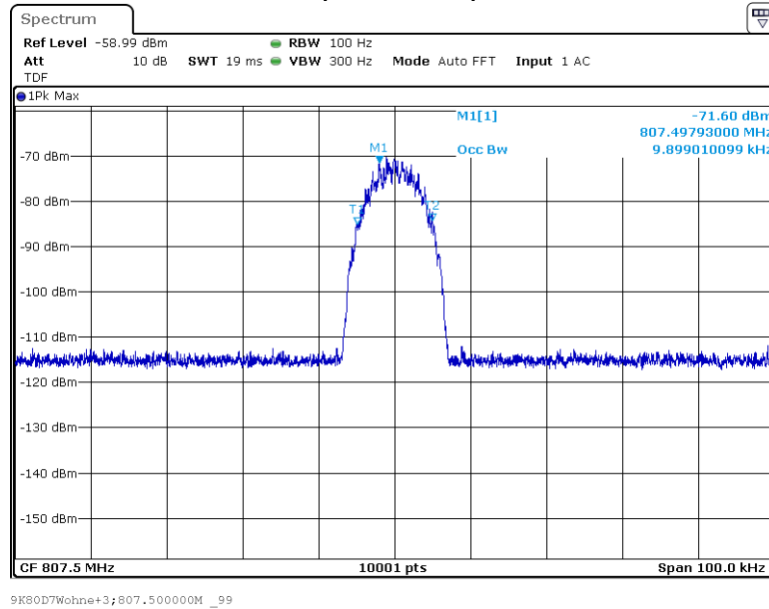

Input Signal

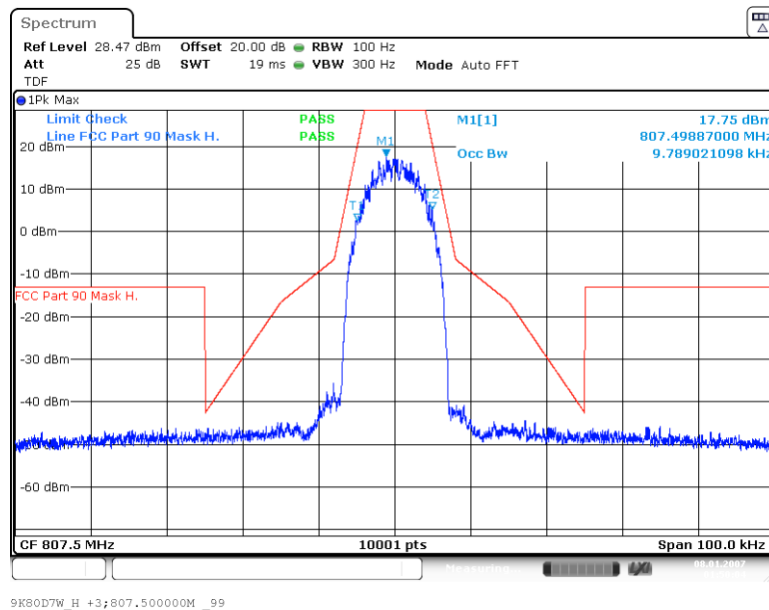

Output Signal

4.2.9.10 FREQUENCY BAND = 809 MHz – 817 MHz

Frequency Band = 809 MHz – 817 MHz, Direction = RF uplink,
 Input Power = 0.3 dB < AGC, at **fm** Signal Type = 4K00F3E
 (S01_AA01)

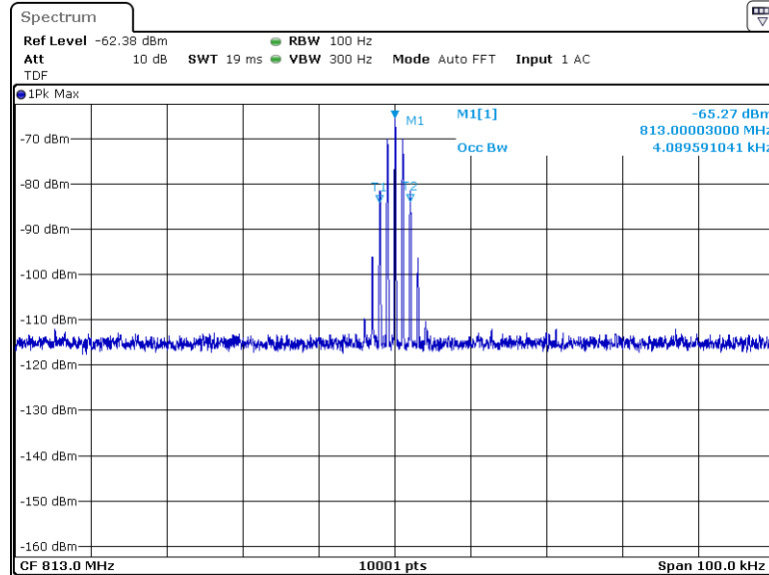

4K00F3Eohne-0.3;813.000000M_99

Input Signal

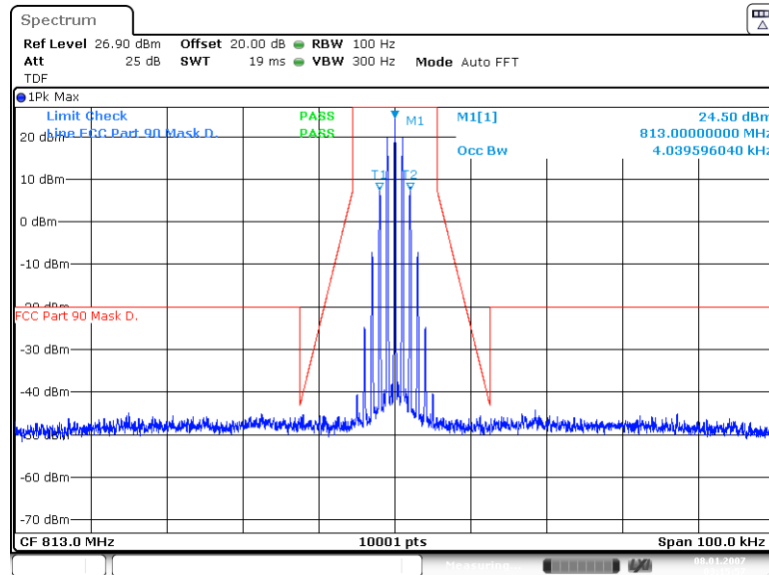

4K00F3E_D -0.3;813.000000M_99

Output Signal

Frequency Band = 809 MHz – 817 MHz, Direction = RF uplink,
Input Power = 3 dB > AGC, at **fm** Signal Type = 4K00F3E
(S01_AA01)

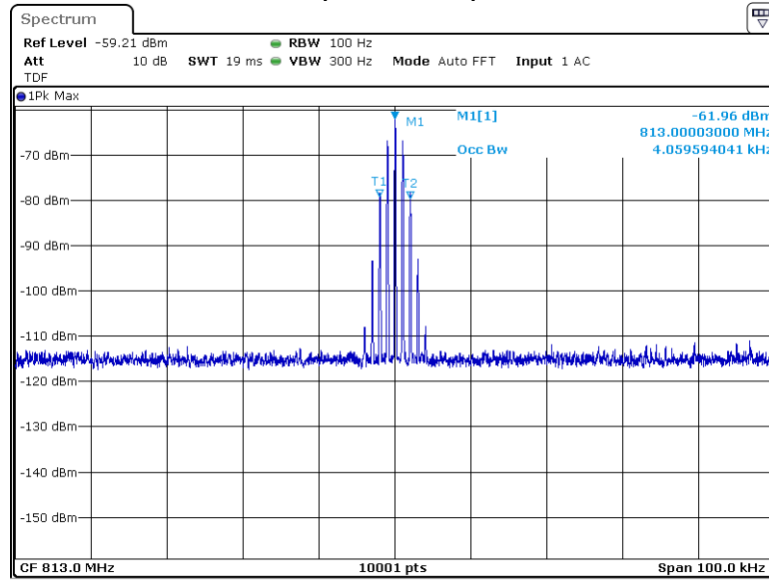

Input Signal

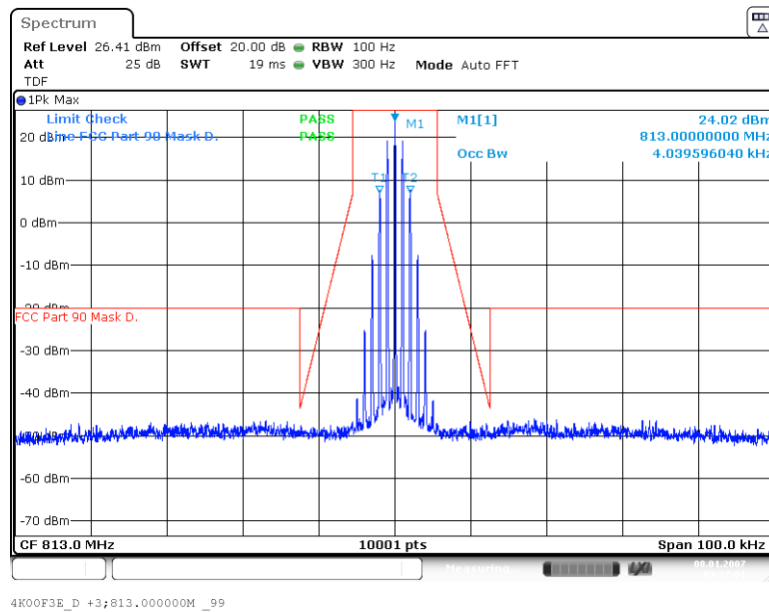

Output Signal

Frequency Band = 809 MHz – 817 MHz, Direction = RF uplink,
 Input Power = 0.3 dB < AGC, at **fm** Signal Type = 11K3F3E
 (S01_AA01)

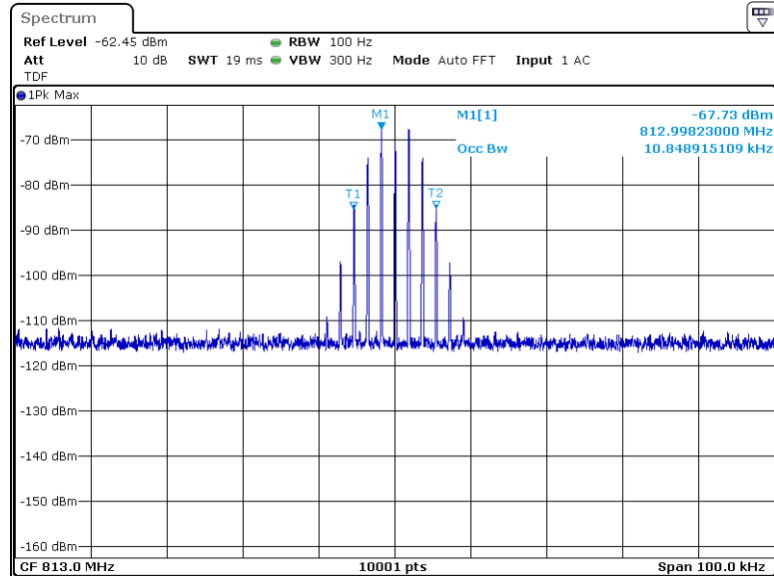

Input Signal

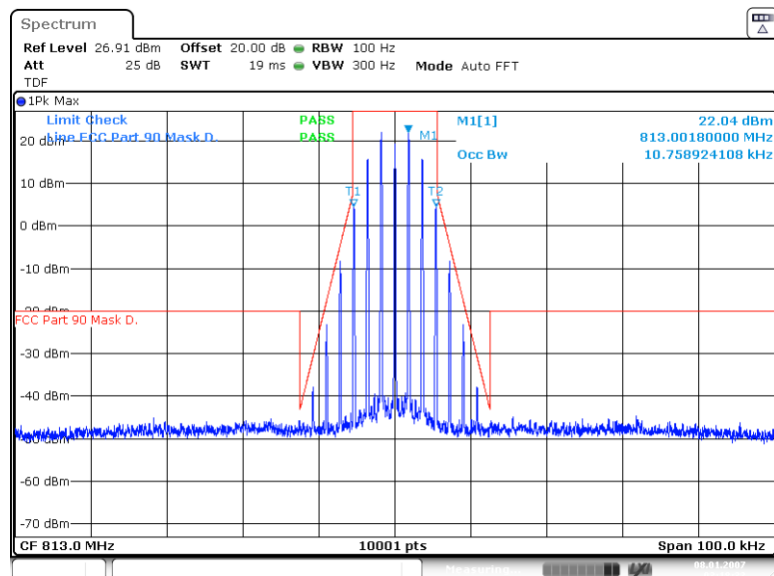

Output Signal

Frequency Band = 809 MHz – 817 MHz, Direction = RF uplink,
Input Power = 3 dB > AGC, at **fm** Signal Type = 11K3F3E
(S01_AA01)

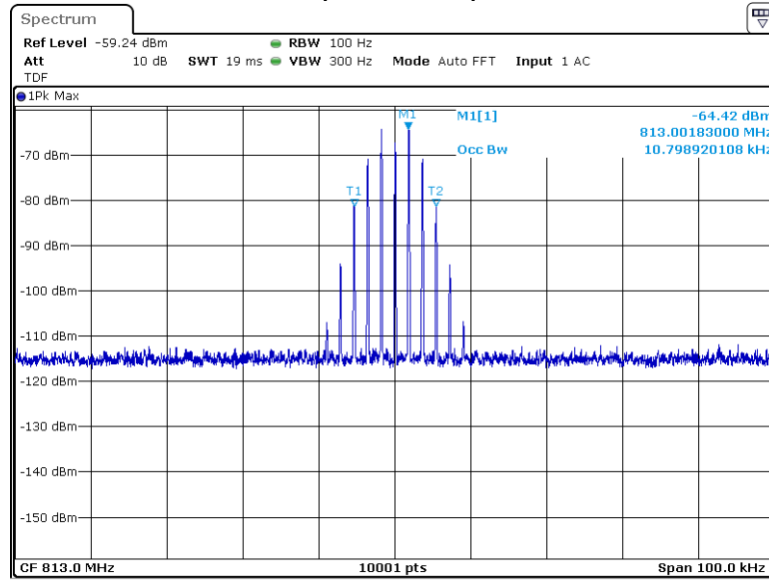

Input Signal

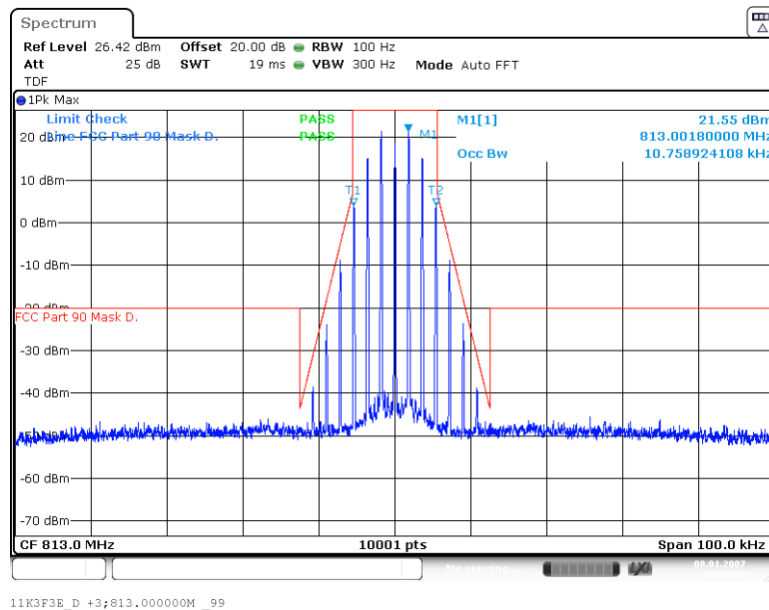

Output Signal

Frequency Band = 809 MHz – 817 MHz, Direction = RF uplink,
 Input Power = 0.3 dB < AGC, at **fm** Signal Type = 8K10F1D
 (S01_AA01)

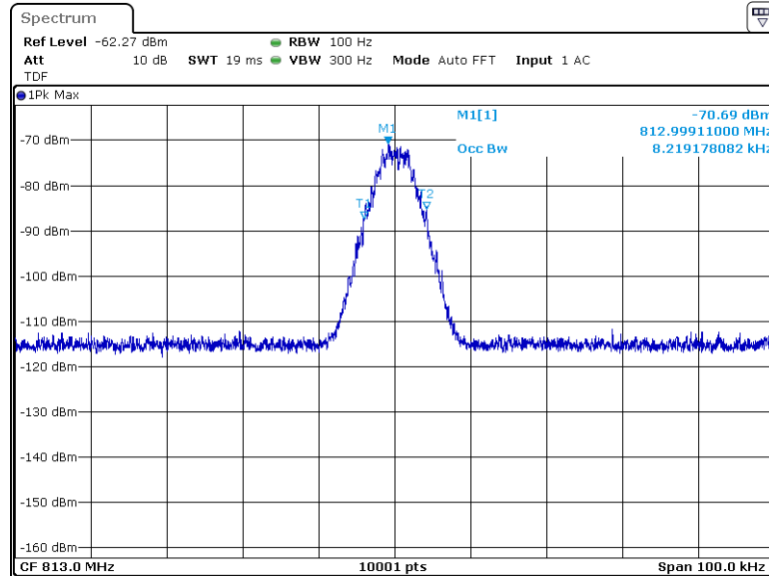

8K10F1Dohne-0.3;813.000000M_99

Input Signal

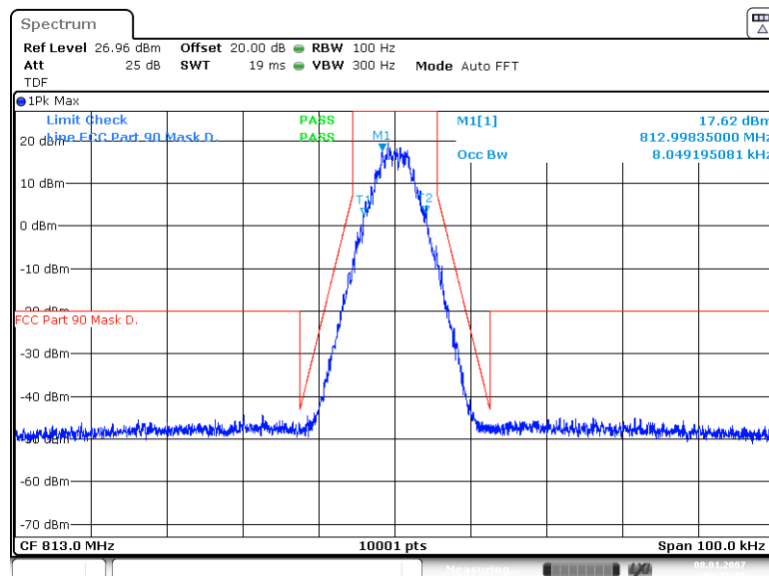

8K10F1D_D -0.3;813.000000M_99

Output Signal

Frequency Band = 809 MHz – 817 MHz, Direction = RF uplink,
Input Power = 3 dB > AGC, at **fm** Signal Type = 8K10F1D
(S01_AA01)

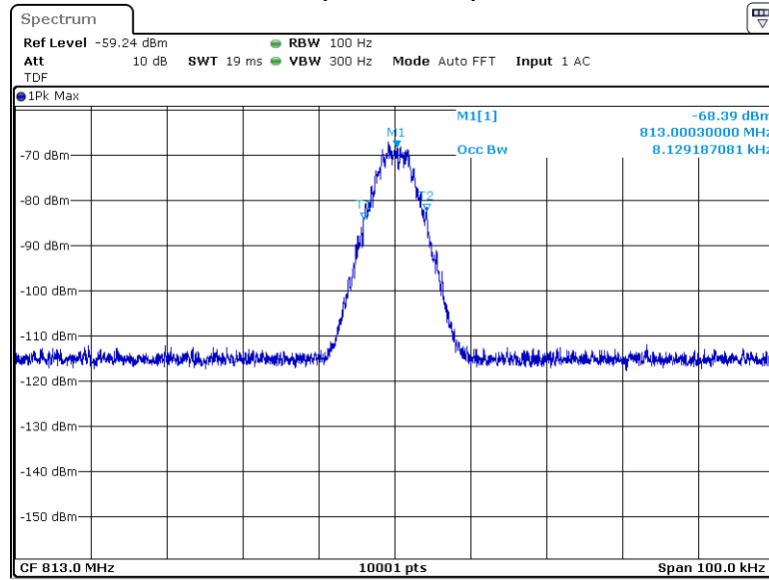

Input Signal

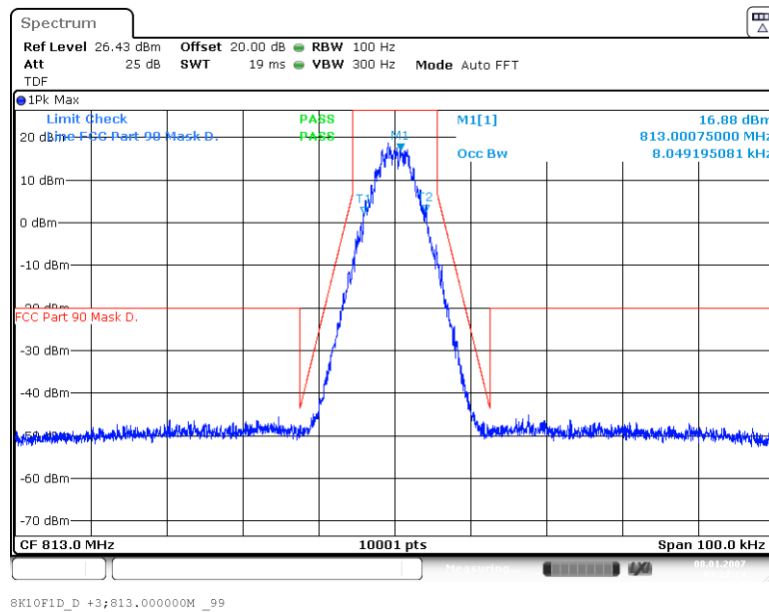

Output Signal

Frequency Band = 809 MHz – 817 MHz, Direction = RF uplink,
Input Power = 0.3 dB < AGC, at **fm** Signal Type = 9K80D7W
(S01_AA01)

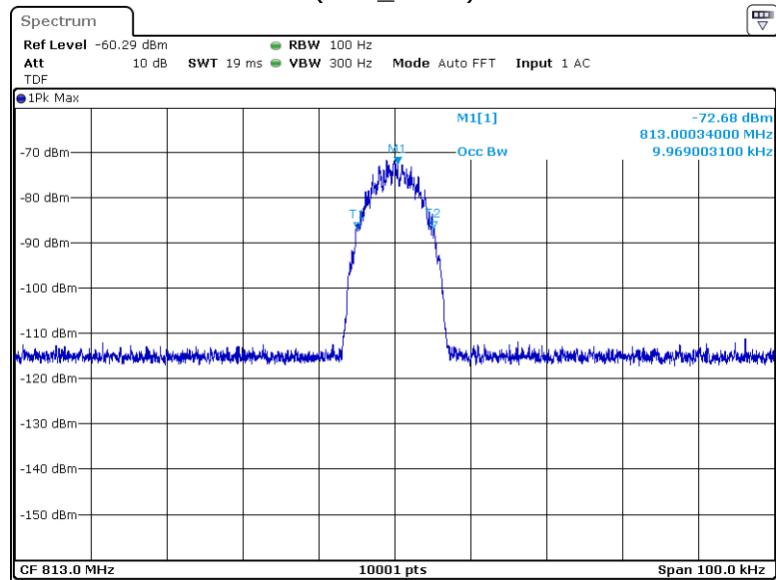

Input Signal

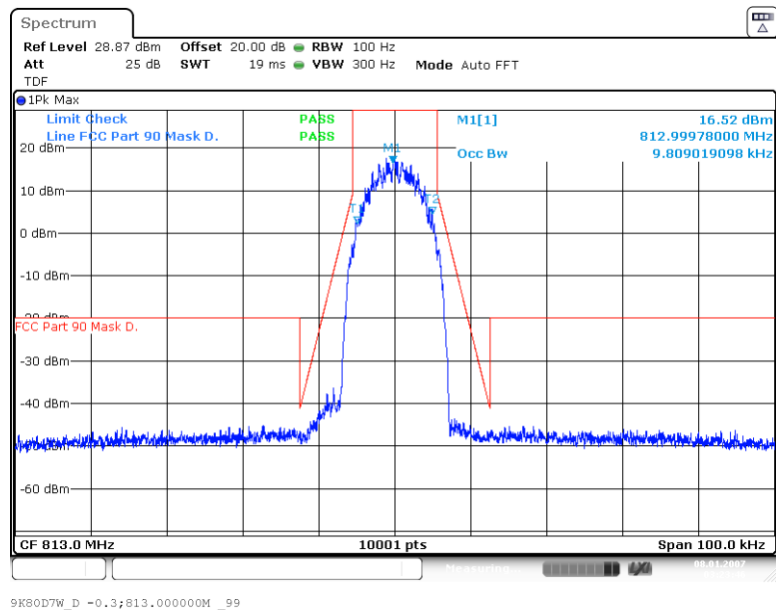

Output Signal

Frequency Band = 809 MHz – 817 MHz, Direction = RF uplink,
Input Power = 3 dB > AGC, at **fm** Signal Type = 9K80D7W
(S01_AA01)

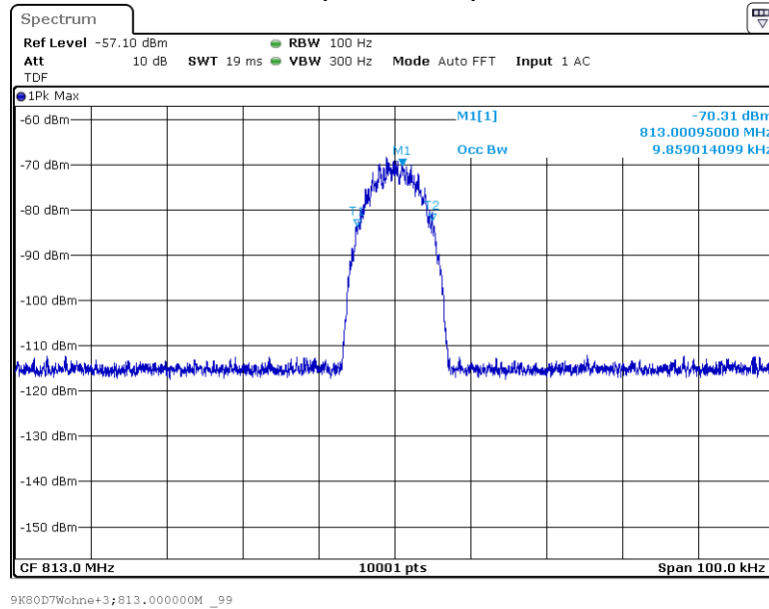

Input Signal

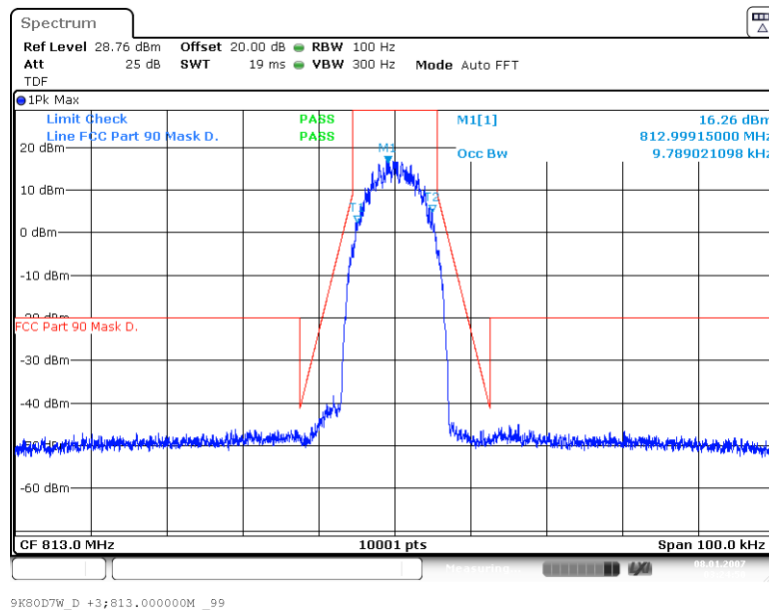

Output Signal

4.2.9.11 FREQUENCY BAND = 817 MHz – 824 MHz

Frequency Band = 817 MHz – 824 MHz, Direction = RF uplink,
 Input Power = 0.3 dB < AGC, at **fm** Signal Type = 4K00F3E
 (S01_AA01)

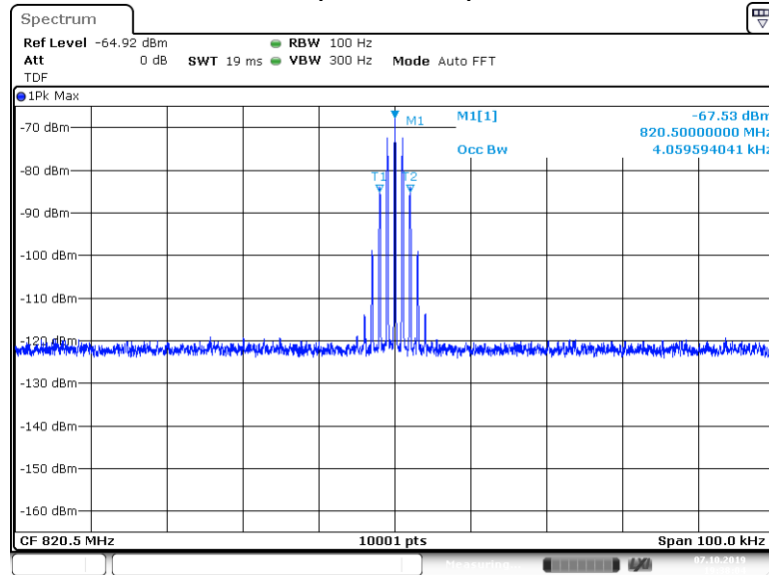

4K00F3Eohne-0.3;820.500000M _99

Input Signal

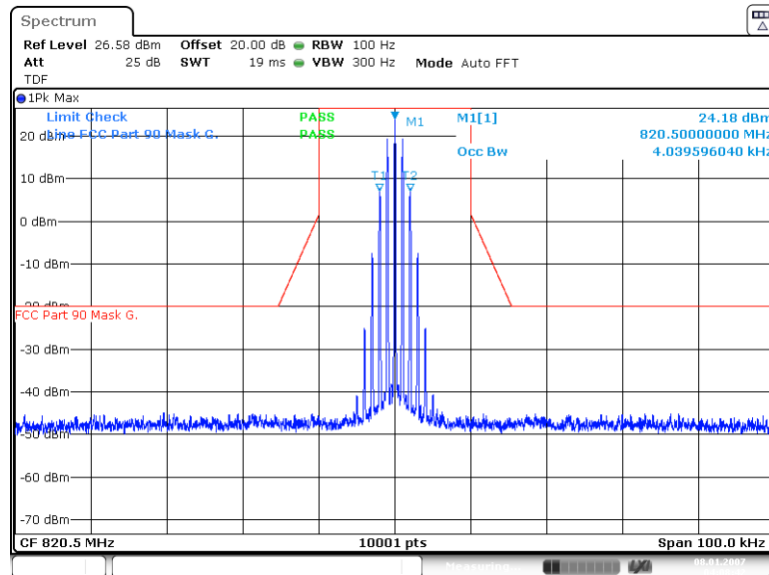

4K00F3E_G -0.3;820.500000M _99

Output Signal

Frequency Band = 817 MHz – 824 MHz, Direction = RF uplink,
Input Power = 3 dB > AGC, at **fm** Signal Type = 4K00F3E
(S01_AA01)

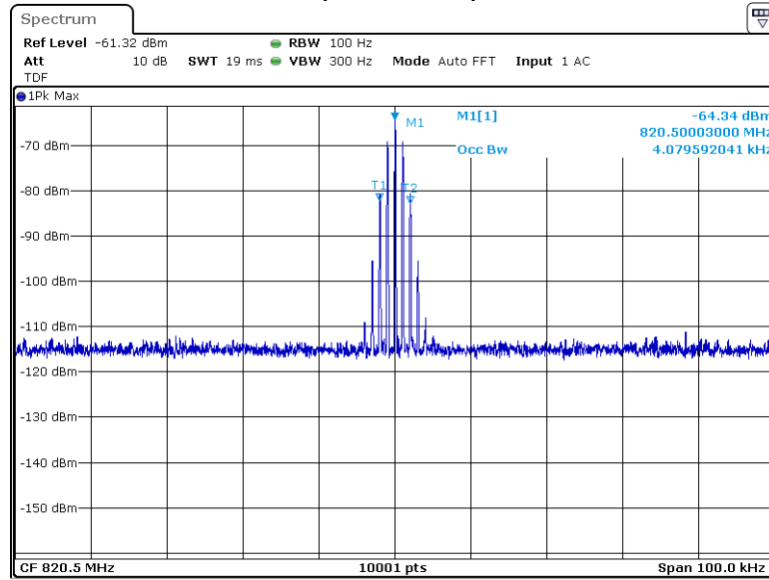

Input Signal

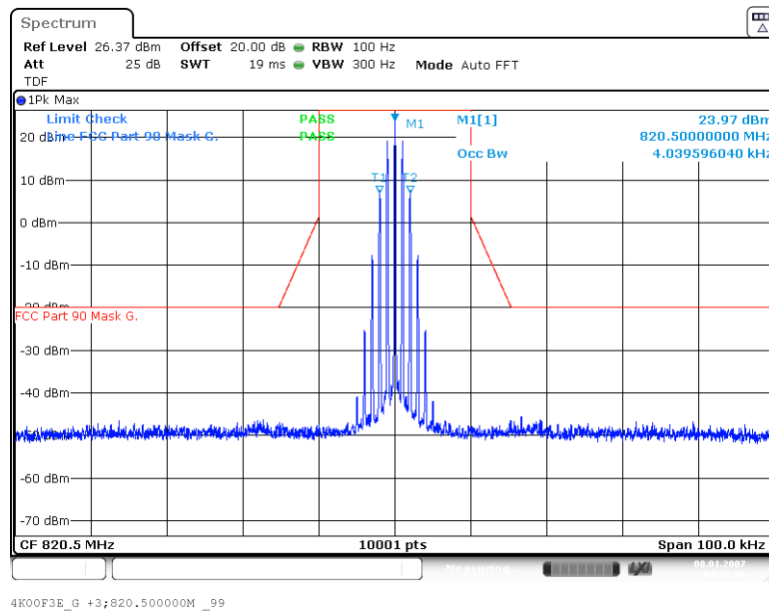

Output Signal

Frequency Band = 817 MHz – 824 MHz, Direction = RF uplink,
 Input Power = 0.3 dB < AGC, at **fm** Signal Type = 11K3F3E
 (S01_AA01)

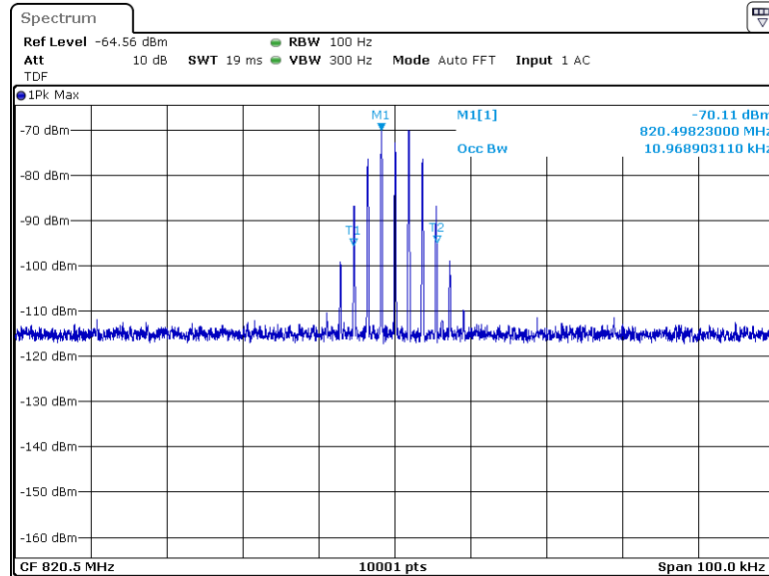

11K3F3Eohne-0.3;820.500000M_99

Input Signal

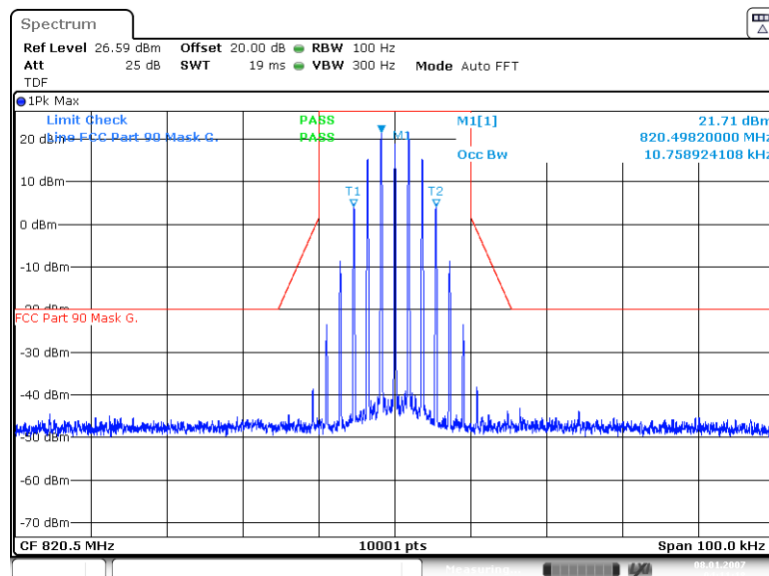

11K3F3E_G -0.3;820.500000M_99

Output Signal

Frequency Band = 817 MHz – 824 MHz, Direction = RF uplink,
Input Power = 3 dB > AGC, at **fm** Signal Type = 11K3F3E
(S01_AA01)

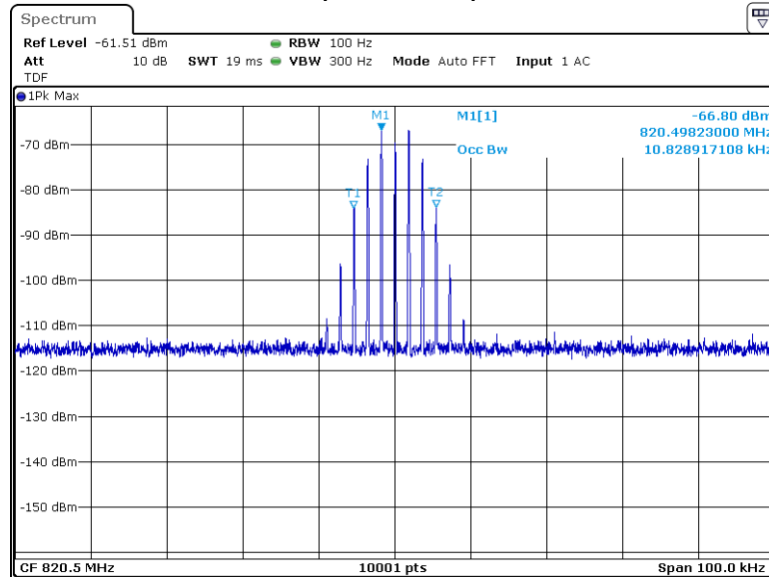

11K3F3Eohne+3;820.500000M_99

Input Signal

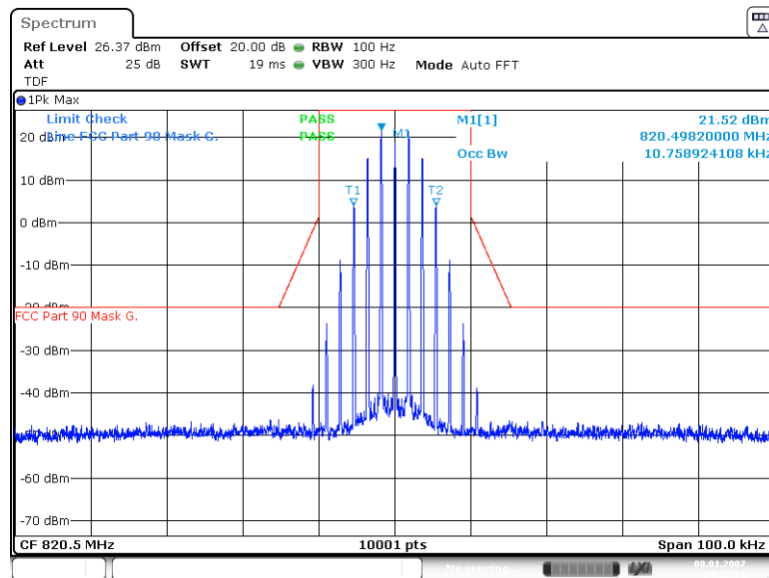

11K3F3E_G +3;820.500000M_99

Output Signal

Frequency Band = 817 MHz – 824 MHz, Direction = RF uplink,
 Input Power = 0.3 dB < AGC, at **fm** Signal Type = 8K10F1D
 (S01_AA01)

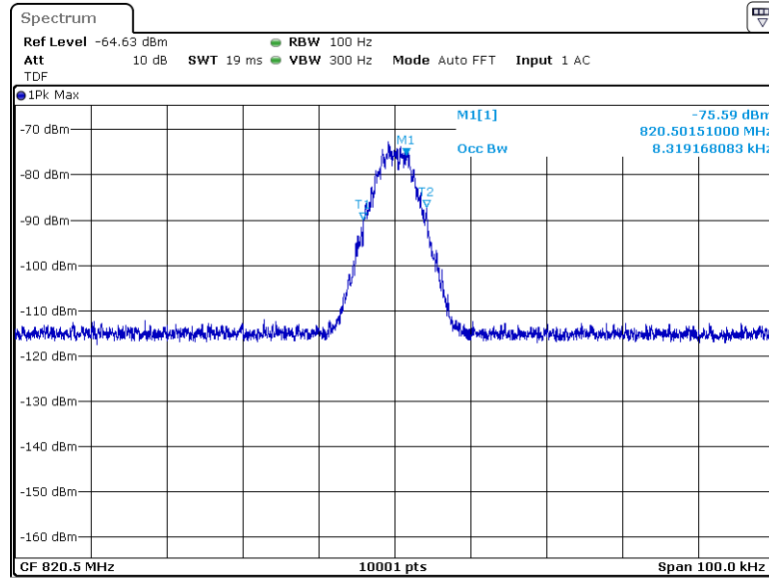

8K10F1Dohne-0.3;820.500000M _99

Input Signal

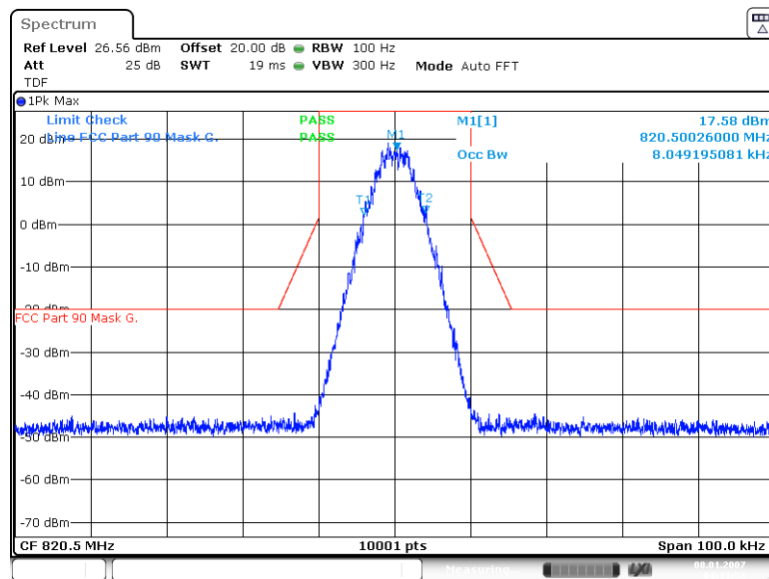

8K10F1D_G -0.3;820.500000M _99

Output Signal

Frequency Band = 817 MHz – 824 MHz, Direction = RF uplink,
Input Power = 3 dB > AGC, at **fm** Signal Type = 8K10F1D
(S01_AA01)

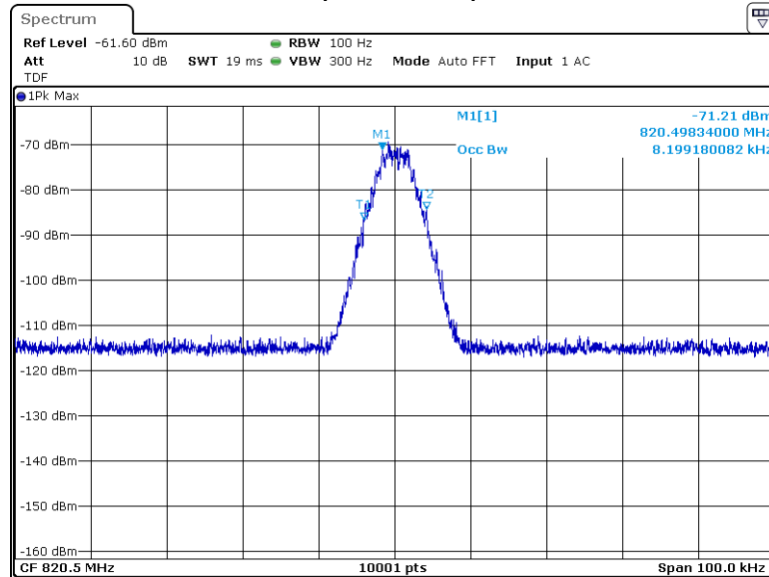

8K10F1Dohne+3;820.500000M_99

Input Signal

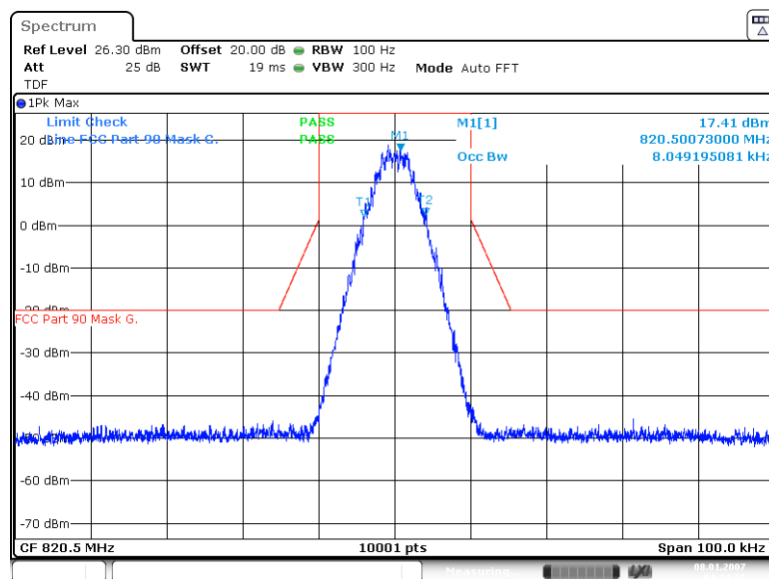

8K10F1D_G +3;820.500000M_99

Output Signal

Frequency Band = 817 MHz – 824 MHz, Direction = RF uplink,
Input Power = 0.3 dB < AGC, at **fm** Signal Type = 9K80D7W
(S01_AA01)

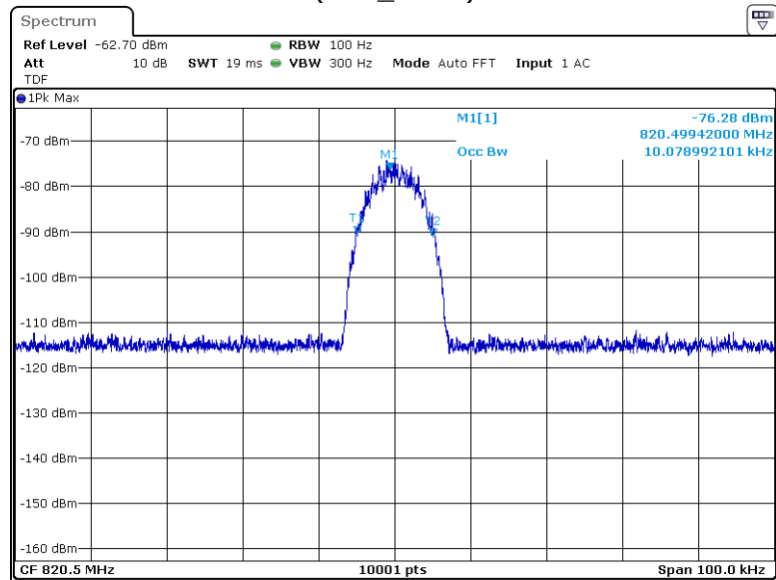

Input Signal

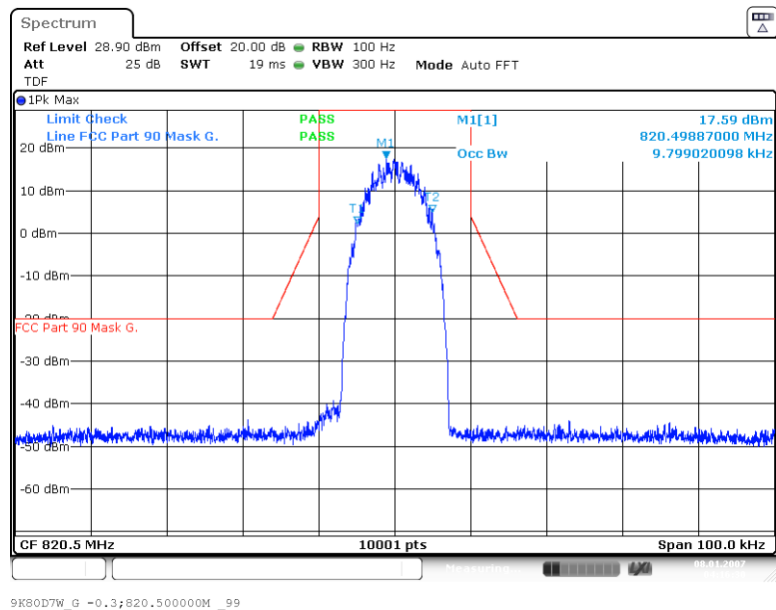

Output Signal

Frequency Band = 817 MHz – 824 MHz, Direction = RF uplink,
Input Power = 3 dB > AGC, at **fm** Signal Type = 9K80D7W
(S01_AA01)

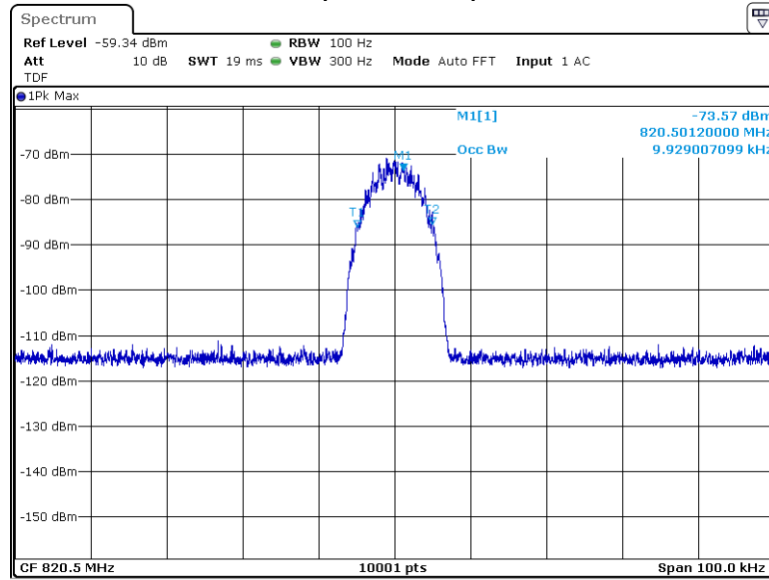

Input Signal

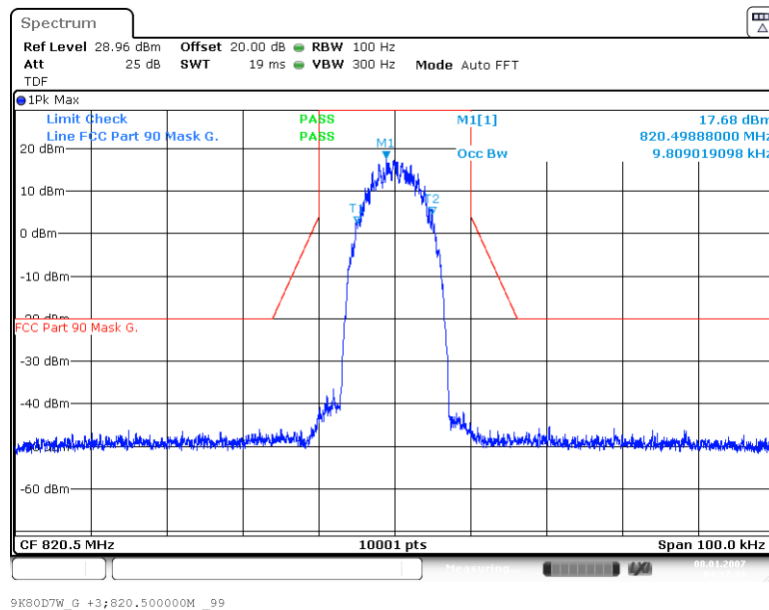

Output Signal

Frequency Band = 817 MHz – 824 MHz, Direction = RF uplink,
Input Power = 0.3 dB < AGC, at **fm** Signal Type = 16K0F3E
(S01_AA01)

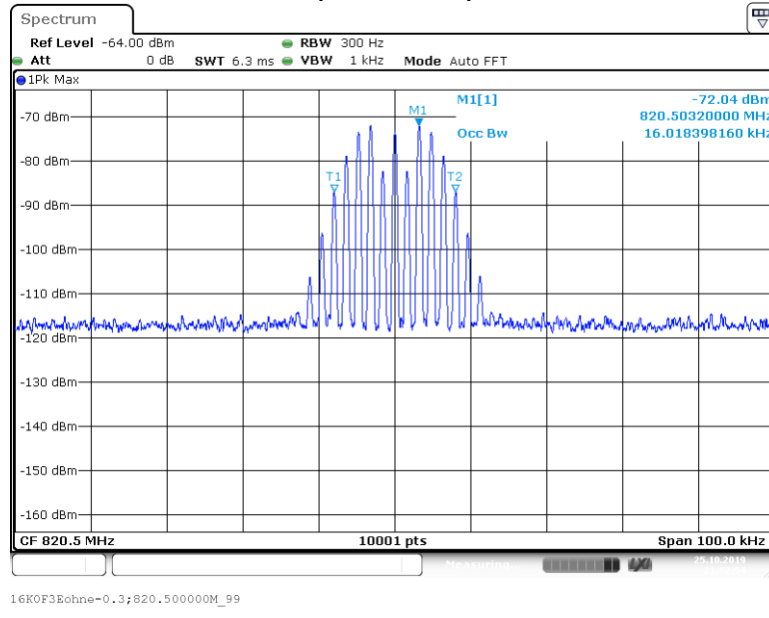

Input Signal

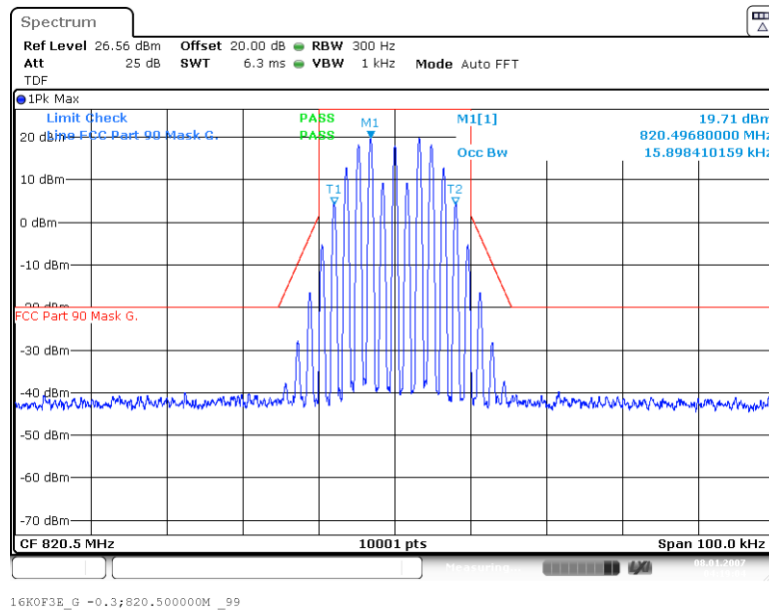

Output Signal

Frequency Band 817 MHz – 824 MHz, Direction = RF uplink,
 Input Power = 3 dB > AGC, at **fm** Signal Type = 16K0F3E
 (S01_AA01)

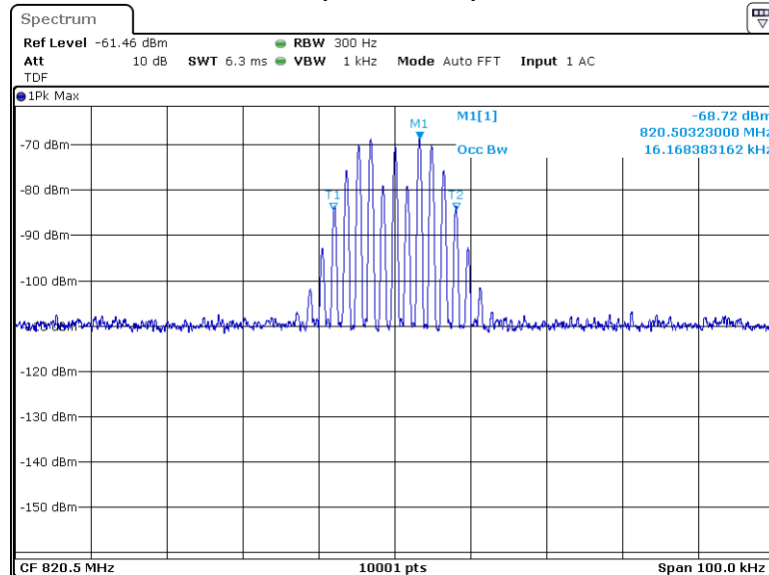

Input Signal

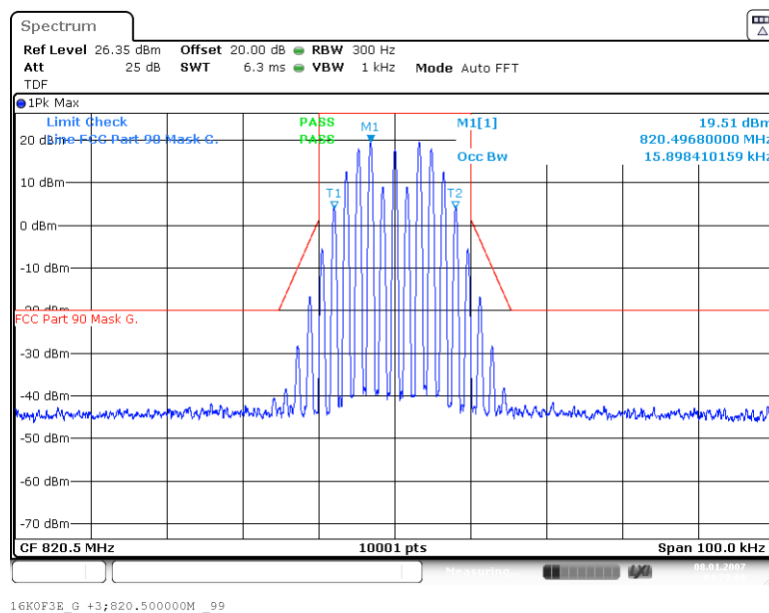

Output Signal

4.2.10 TEST EQUIPMENT USED

FCC cond. Test Lab, BV Nbg

4.3 CONDUCTED SPURIOUS EMISSIONS AT ANTENNA TERMINALS

Standard FCC Part 2.1051, FCC Part 90: §90.543, §90.691

The test was performed according to:
ANSI C63.26

4.3.1 TEST DESCRIPTION

This test case is intended to demonstrate compliance to the applicable conducted spurious emission limits per § 2.1051. The limit comes from the applicable rule part for the operating band

The EUT was connected to the test setup according to the following diagram:

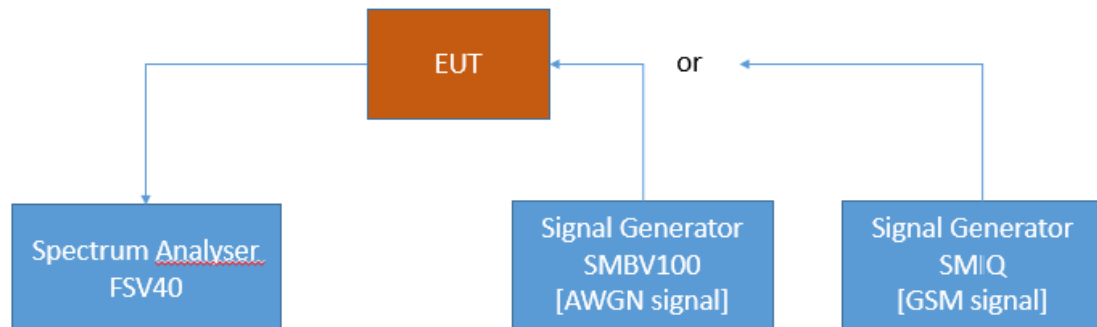

FCC Part 22/24/27/90 Industrial signal booster – Test Setup; Conducted Spurious Emissions

The attenuation of the measuring and stimulus path are known for each measured frequency and are considered.

The Spectrum Analyser settings can be directly found in the measurement diagrams.

4.3.2 TEST REQUIREMENTS / LIMITS

FCC Part 2.1051; Measurement required: Spurious emissions at antenna terminal:

The radio frequency voltage or powers generated within the equipment and appearing on a spurious frequency shall be checked at the equipment output terminals when properly loaded with a suitable artificial antenna. Curves or equivalent data shall show the magnitude of each harmonic and other spurious emission that can be detected when the equipment is operated under the conditions specified in §2.1049 as appropriate. The magnitude of spurious emissions which are attenuated more than 20 dB below the permissible value need not be specified.

Part 90, Subpart I/R

Band 758 MHz – 768 MHz

§90.543 – Emission limitations

(e) For operations in the 758-768 MHz and the 788-798 MHz bands, the power of any emission outside the licensee's frequency band(s) of operation shall be attenuated below the transmitter power (P) within the licensed band(s) of operation, measured in watts, in accordance with the following:

(1) On all frequencies between 769-775 MHz and 799-805 MHz, by a factor not less than $76 + 10 \log (P)$ dB in a 6.25 kHz band segment, for base and fixed stations.

(3) On any frequency between 775-788 MHz, above 805 MHz, and below 758 MHz, by at least $43 + 10 \log (P)$ dB.

(f) For operations in the 758-775 MHz and 788-805 MHz bands, all emissions including harmonics in the band 1559-1610 MHz shall be limited to -70 dBW/MHz equivalent isotropically radiated power (EIRP) for wideband signals, and -80 dBW EIRP for discrete emissions of less than 700 Hz bandwidth. For the purpose of equipment authorization, a transmitter shall be tested with an antenna that is representative of the type that will be used with the equipment in normal operation.

Part 90, Subpart I/S

Band 862 MHz – 869 MHz

§90.691 Emission mask requirements for EA-based systems

(a) Out-of-band emission requirement shall apply only to the "outer" channels included in an EA license and to spectrum adjacent to interior channels used by incumbent licensees. The emission limits are as follows:

(2) For any frequency removed from the EA licensee's frequency block greater than 37.5 kHz, the power of any emission shall be attenuated below the transmitter power (P) in watts by at least $43 + 10 \log_{10}(P)$ decibels or 80 decibels, whichever is the lesser attenuation, where f is the frequency removed from the center of the outer channel in the block in kilohertz and where f is greater than 37.5 kHz.

4.3.3 TEST PROTOCOL

758 - 768 MHz, downlink							
Test Frequency	Signal Type	Spurious Freq. [MHz]	Spurious Level [dBm]	Detector	RBW [kHz]	Limit [dBm]	Margin to Limit [dB]
low	CW	757.979	-33.9	Peak	1	-33.0	0.9
low	CW	775.400	-22.5	Peak	100	-13.0	9.5
low	CW	852.988	-18.7	Peak	100	-13.0	5.7
low	CW	772.500	-46.7	RMS	6.25	-46.0	0.7
mid	CW	768.060	-41.1	Peak	1	-33.0	4.1
mid	CW	775.267	-23.0	Peak	100	-13.0	10.0
mid	CW	853.684	-20.2	Peak	100	-13.0	7.2
mid	CW	772.500	-47.9	RMS	6.25	-46.0	1.9
high	CW	768.023	-34.1	Peak	1	-33.0	1.1
high	CW	775.627	-23.5	Peak	100	-13.0	10.5
high	CW	861.869	-20.6	Peak	100	-13.0	7.6
high	CW	769.296	-50.5	RMS	6.25	-46.0	4.5

788 - 798 MHz, uplink							
Test Frequency	Signal Type	Spurious Freq. [MHz]	Spurious Level [dBm]	Detector	RBW [kHz]	Limit [dBm]	Margin to Limit [dB]
low	CW	787.977	-37.3	Peak	1	-33.0	4.3
low	CW	819.302	-20.1	Peak	100	-13.0	7.1
low	CW	800.001	-48.5	RMS	6.25	-46.0	2.5
mid	CW	787.984	-38.3	Peak	1	-33.0	5.3
mid	CW	819.745	-19.5	Peak	100	-13.0	16.5
mid	CW	802.499	-51.0	RMS	6.25	-46.0	5.0
high	CW	798.016	-38.4	Peak	1	-33.0	5.4
high	CW	821.305	-19.8	Peak	100	-13.0	6.8
high	CW	800.889	-50.5	RMS	6.25	-46.0	4.5

Remarks:

At measuring spurious responses in RMS mode in bands 769 MHz to 775 MHz respectively 799 MHz to 805 MHz these bands are switched off and the frequencies low, mid and high are given in the switched on neighbor bands 758 MHz to 768 MHz respectively 788 MHz to 798 MHz.

769 - 775 MHz, downlink							
Test Frequency	Signal Type	Spurious Freq. [MHz]	Spurious Level [dBm]	Detector	RBW [kHz]	Limit [dBm]	Margin to Limit [dB]
low	CW	760.178	-21.7	Peak	100	-13.0	8.7
low	CW	768.977	-33.3	Peak	1	-33.0	0.3
low	CW	851.746	-20.6	Peak	100	-13.0	7.6
mid	CW	763.201	-21.1	Peak	100	-13.0	8.1
mid	CW	768.945	-40.2	Peak	1	-33.0	7.2
mid	CW	857.827	-20.5	Peak	100	-13.0	7.5
high	CW	762.673	-21.0	Peak	100	-13.0	8.0
high	CW	775.022	-34.3	Peak	1	-33.0	1.3
high	CW	852.574	-20.5	Peak	100	-13.0	7.5

799 - 805 MHz, uplink							
Test Frequency	Signal Type	Spurious Freq. [MHz]	Spurious Level [dBm]	Detector	RBW [kHz]	Limit [dBm]	Margin to Limit [dB]
low	CW	798.972	-37.2	Peak	1	-33.0	4.2
low	CW	805.722	-29.8	Peak	10	-23.0	6.8
low	CW	822.451	-19.4	Peak	100	-13.0	6.4
mid	CW	798.951	-40.7	Peak	1	-33.0	7.7
mid	CW	805.778	-30.9	Peak	10	-23.0	7.9
mid	CW	816.835	-18.8	Peak	100	-13.0	5.8
high	CW	805.032	-37.3	Peak	1	-33.0	4.3
high	CW	805.799	-30.9	Peak	10	-23.0	7.9
high	CW	822.306	-19.2	Peak	100	-13.0	6.2

851 - 854 MHz, downlink							
Test Frequency	Signal Type	Spurious Freq. [MHz]	Spurious Level [dBm]	Detector	RBW [kHz]	Limit [dBm]	Margin to Limit [dB]
low	CW	771.686	-19.4	Peak	100	-13.0	6.4
low	CW	850.993	-34.3	Peak	1	-33.0	1.3
low	CW	863.301	-19.8	Peak	100	-13.0	6.8
mid	CW	763.958	-20.4	Peak	100	-13.0	7.4
mid	CW	854.000	-40.1	Peak	1	-33.0	7.1
mid	CW	857.433	-21.1	Peak	100	-13.0	8.1
high	CW	772.562	-19.7	Peak	100	-13.0	6.7
high	CW	854.038	-33.1	Peak	1	-33.0	0.1
high	CW	867.881	-19.6	Peak	100	-13.0	6.6

806 - 809 MHz, uplink							
Test Frequency	Signal Type	Spurious Freq. [MHz]	Spurious Level [dBm]	Detector	RBW [kHz]	Limit [dBm]	Margin to Limit [dB]
low	CW	805.977	-37.5	Peak	1	-33.0	4.5
low	CW	809.547	-29.2	Peak	10	-23.0	6.2
low	CW	820.487	-20.5	Peak	100	-13.0	7.5
mid	CW	805.771	-30.4	Peak	10	-23.0	7.4
mid	CW	809.080	-40.6	Peak	1	-33.0	7.6
mid	CW	820.189	-19.9	Peak	100	-13.0	6.9
high	CW	805.749	-30.0	Peak	10	-23.0	7.0
high	CW	809.026	-37.2	Peak	1	-33.0	4.2
high	CW	818.851	-19.3	Peak	100	-13.0	6.3

854 - 862 MHz, downlink							
Test Frequency	Signal Type	Spurious Freq. [MHz]	Spurious Level [dBm]	Detector	RBW [kHz]	Limit [dBm]	Margin to Limit [dB]
low	CW	766.148	-20.3	Peak	100	-13.0	7.3
low	CW	851.827	-20.0	Peak	100	-13.0	7.0
low	CW	853.970	-34.0	Peak	1	-33.0	1.0
mid	CW	765.375	-19.9	Peak	100	-13.0	6.9
mid	CW	862.003	-38.1	Peak	1	-33.0	5.1
mid	CW	865.665	-19.8	Peak	100	-13.0	6.8
high	CW	768.733	-19.8	Peak	100	-13.0	7.3
high	CW	862.000	-41.2	RMS	1	-33.0	8.2
high	CW	864.279	-20.2	Peak	100	-13.0	7.2

809 - 817 MHz, uplink							
Test Frequency	Signal Type	Spurious Freq. [MHz]	Spurious Level [dBm]	Detector	RBW [kHz]	Limit [dBm]	Margin to Limit [dB]
low	CW	809.000	-38.1	Peak	1	-33.0	5.1
low	CW	817.498	-28.7	Peak	10	-23.0	5.7
low	CW	820.290	-19.7	Peak	100	-13.0	6.7
mid	CW	817.078	-39.7	Peak	1	-33.0	6.7
mid	CW	818.000	-30.7	Peak	10	-23.0	7.7
mid	CW	820.253	-19.4	Peak	100	-13.0	6.4
high	CW	806.990	-19.3	Peak	100	-13.0	6.3
high	CW	817.031	-36.2	Peak	1	-33.0	3.2
high	CW	817.573	-29.2	Peak	10	-23.0	6.2

862 - 869 MHz, downlink							
Test Frequency	Signal Type	Spurious Freq. [MHz]	Spurious Level [dBm]	Detector	RBW [kHz]	Limit [dBm]	Margin to Limit [dB]
low	CW	758.592	-19.7	Peak	100	-13.0	6.7
low	CW	860.247	-20.1	Peak	100	-13.0	7.1
low	CW	861.968	-33.6	Peak	1	-33.0	0.6
mid	CW	767.065	-20.1	Peak	100	-13.0	7.1
mid	CW	852.527	-21.0	Peak	100	-13.0	8.0
mid	CW	861.999	-39.8	Peak	1	-33.0	86.8
high	CW	769.567	-20.0	Peak	100	-13.0	7.0
high	CW	854.544	-20.6	Peak	100	-13.0	7.6
high	CW	869.029	-34.3	Peak	1	-33.0	1.3

817 - 824 MHz, uplink							
Test Frequency	Signal Type	Spurious Freq. [MHz]	Spurious Level [dBm]	Detector	RBW [kHz]	Limit [dBm]	Margin to Limit [dB]
low	CW	805.803	-18.5	Peak	100	-13.0	5.5
low	CW	816.451	-30.7	Peak	10	-23.0	7.7
low	CW	816.973	-37.1	Peak	1	-33.0	4.1
mid	CW	810.085	-20.5	Peak	100	-13.0	7.5
mid	CW	816.878	-30.6	Peak	10	-23.0	7.6
mid	CW	816.928	-39.2	Peak	1	-33.0	6.2
high	CW	806.873	-20.6	Peak	100	-13.0	7.6
high	CW	816.824	-29.4	Peak	10	-23.0	6.4
high	CW	824.033	-37.1	Peak	1	-33.0	4.1

Remark: Please see next sub-clause for the measurement plot.
 The peaks in the measurement plots are (input) wanted signal.

4.3.4 MEASUREMENT PLOT (SHOWING THE HIGHEST VALUE, "WORST CASE")

Frequency Band = Band 758 – 768 MHz, Test Frequency = low, Direction = RF downlink,
Signal Type = CW
(S01_AA01)

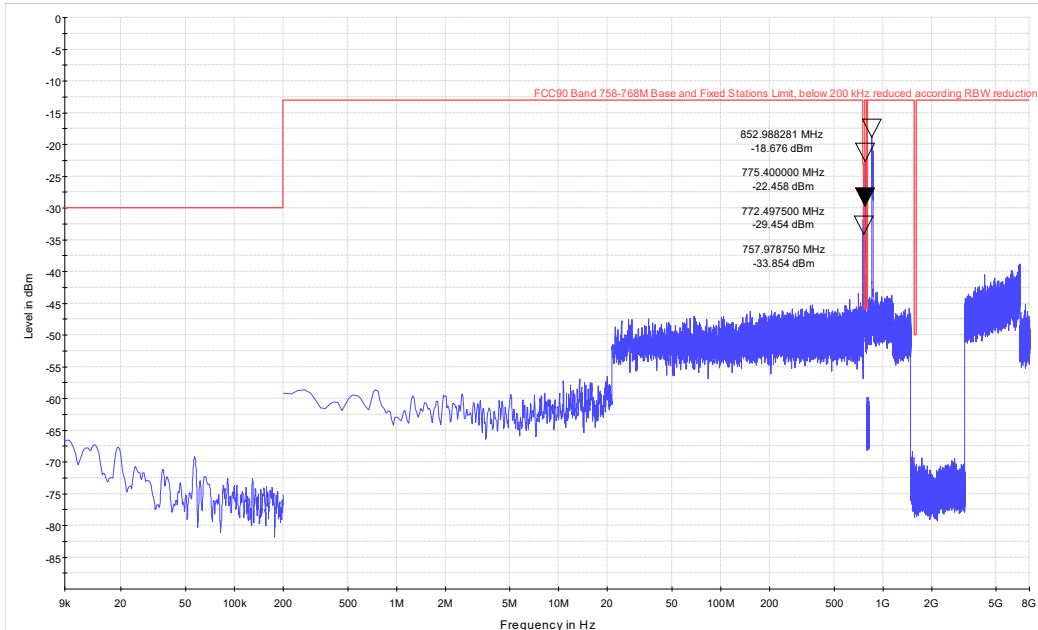

Final measurement range 769 – 775 MHz
(S01_AA01)

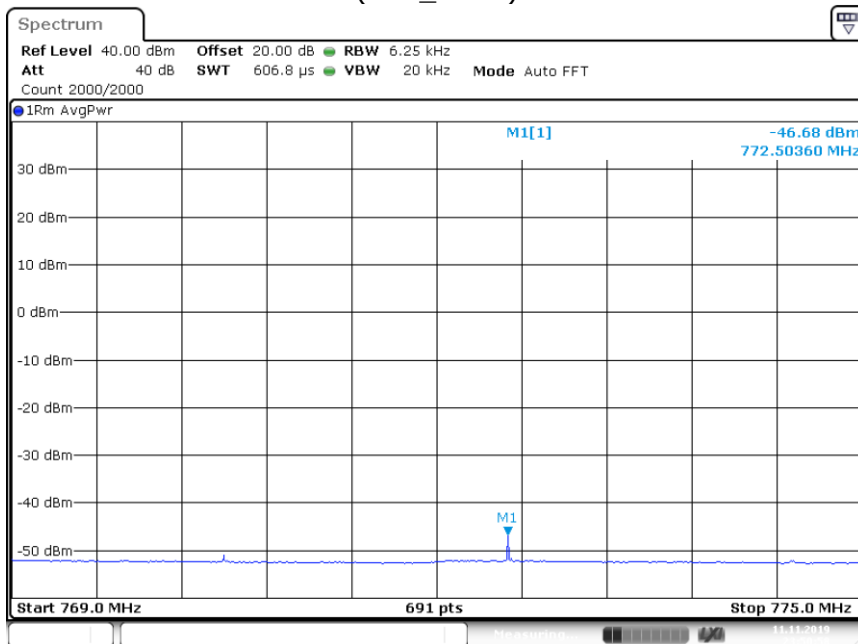

Frequency Band = Band 758 – 768 MHz, Test Frequency = mid, Direction = RF downlink,
Signal Type = CW
(S01_AA01)

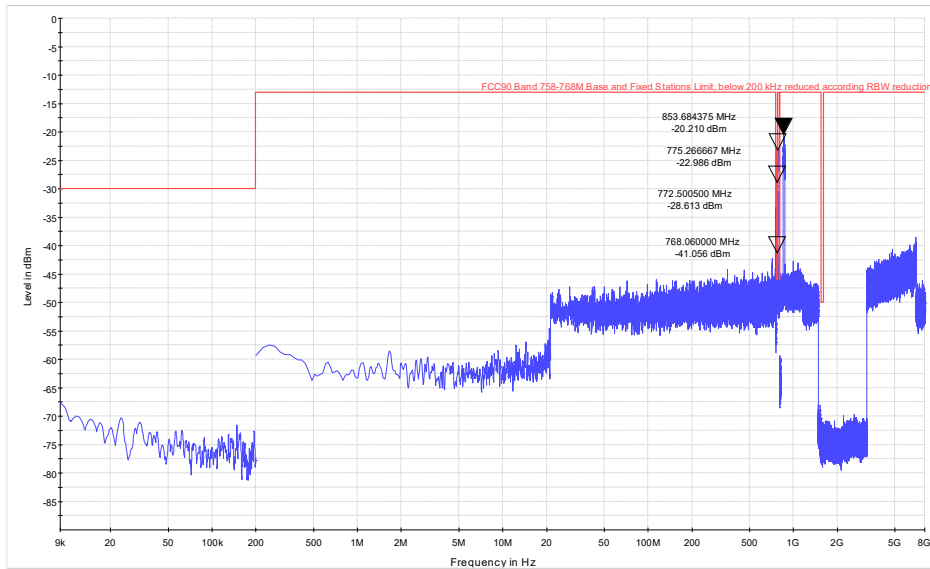

Final measurement range 769 – 775 MHz
(S01_AA01)

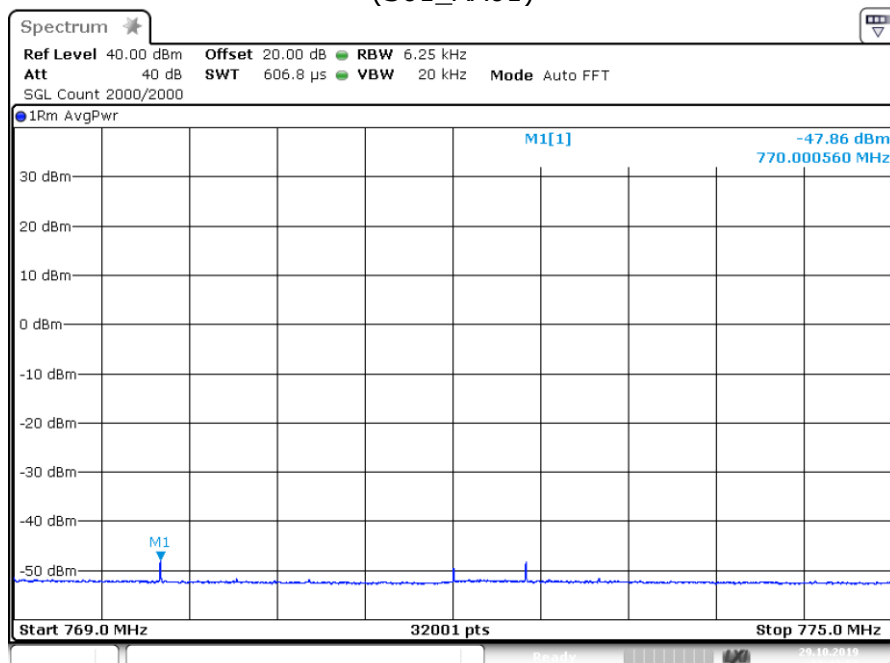

Frequency Band = Band 758 – 768 MHz, Test Frequency = high, Direction = RF downlink,
Signal Type = CW
(S01_AA01)

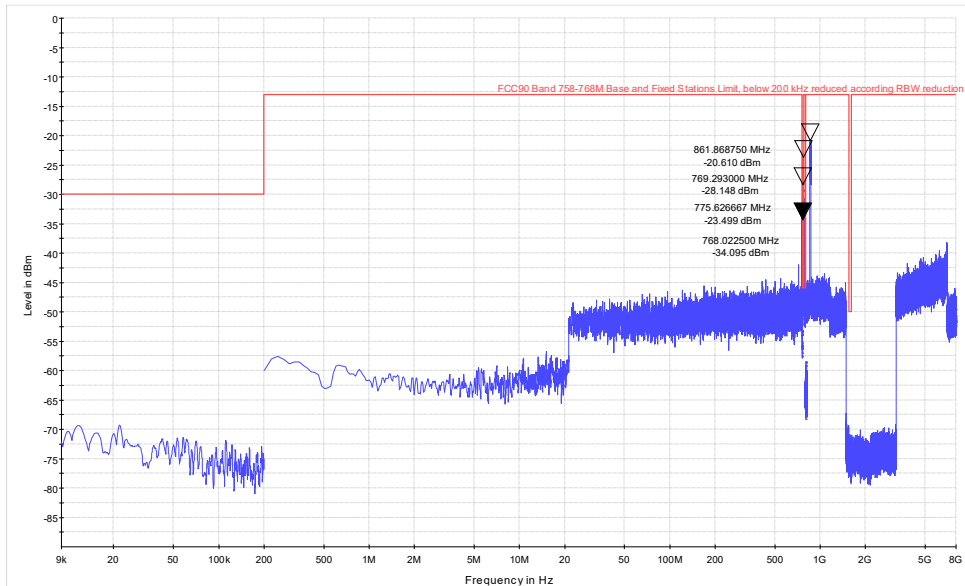

Final measurement range 769 – 775 MHz
(S01_AA01)

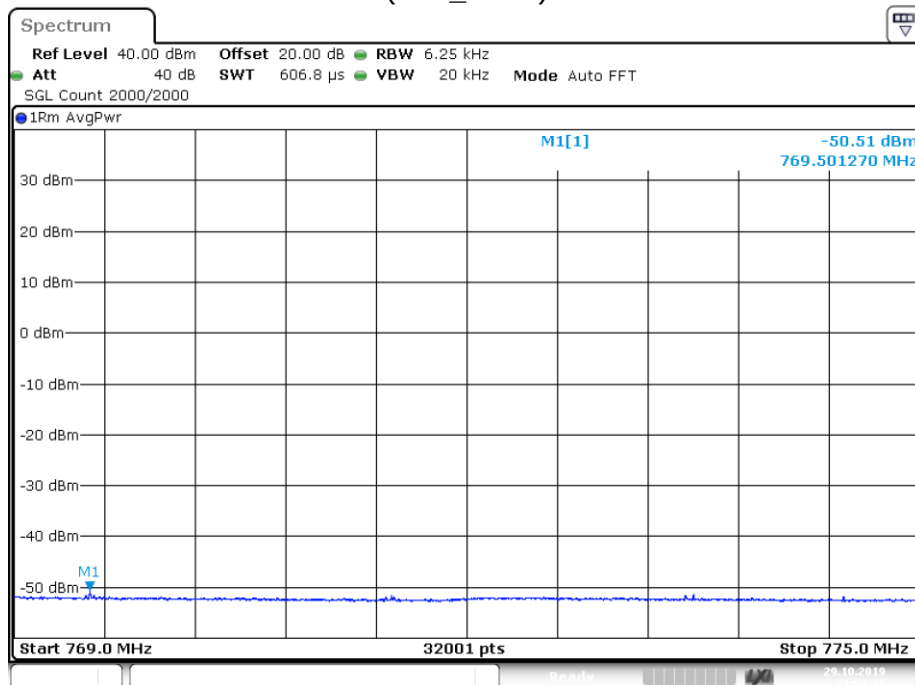

Frequency Band = Band 788 – 798 MHz, Test Frequency = low, Direction = RF uplink, Signal Type = CW (S01_AA01)

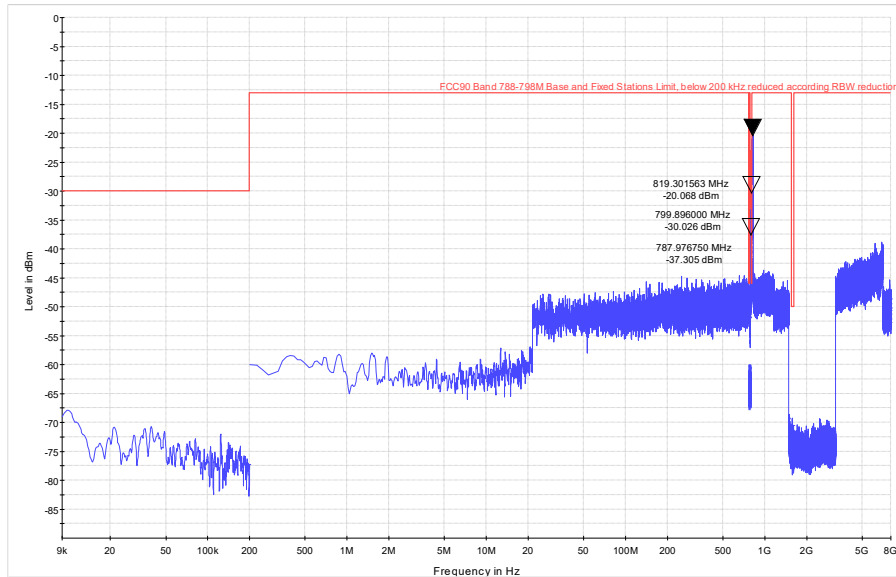

Final measurement range 799 – 805 MHz (S01_AA01)

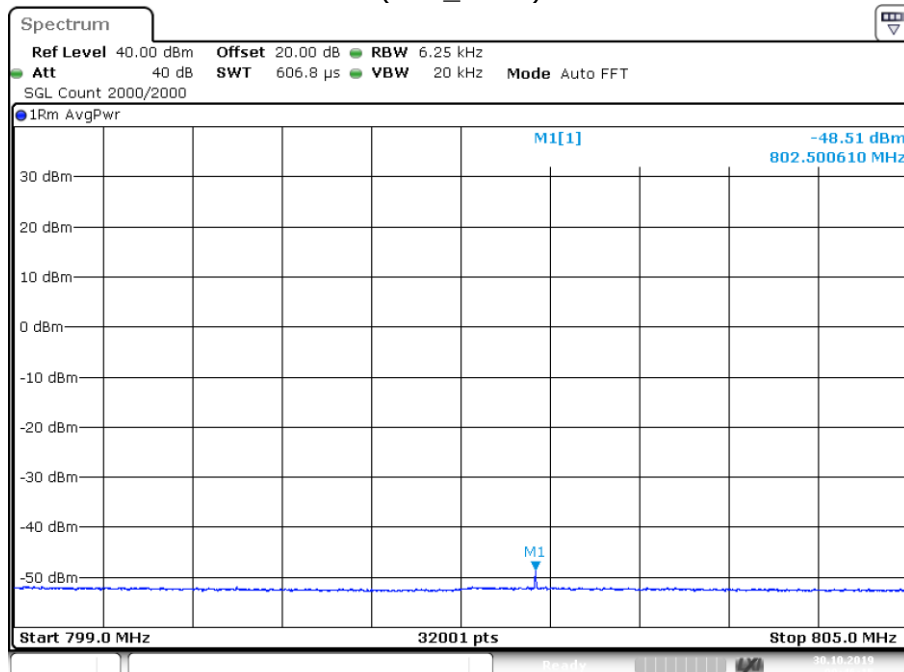

Frequency Band = Band 788 – 798 MHz, Test Frequency = mid, Direction = RF uplink, Signal Type = CW (S01_AA01)

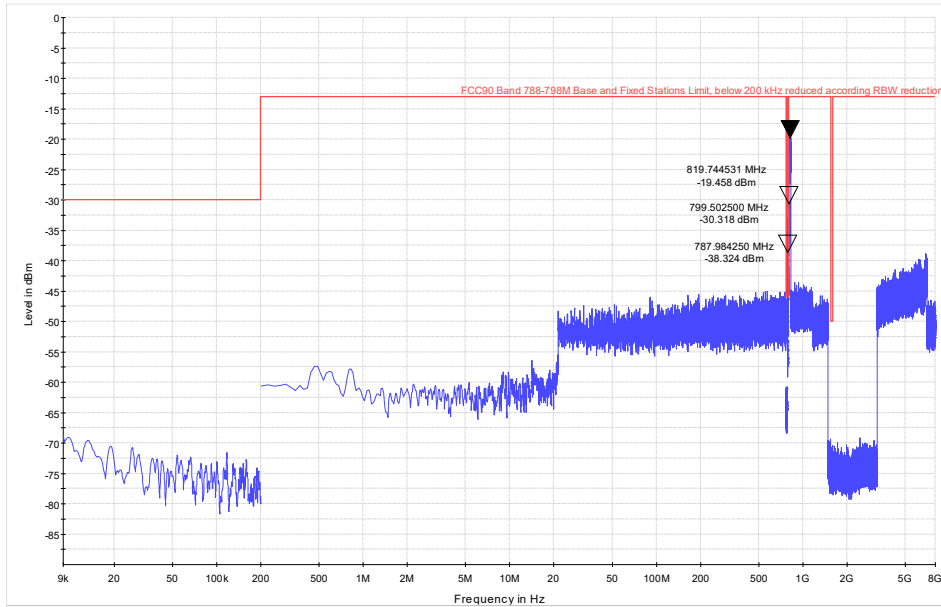

Final measurement range 799 – 805 MHz (S01_AA01)

