

Test Site:
FCC Test Site No.: 96997
IC OATS No.: 3475A-1



ECL-EMC Test Report No.: 10-035

Equipment under test: MR1918/1918/1918
FCC ID: XS5-MR191919
IC ID: 2237E- MR191919
Type of test: **FCC 47 CFR Part 24 Subpart E:2009**
 Broadband PCS
IC RSS-133:2009
 2 GHz Personal Communications Services

Measurement Procedures: 47 CFR Parts 2:2009 (*Frequency Allocations and Radio Treaty Matters; General Rules and Regulations*), Part 24:2009 (Broadband PCS), ANSI/TIA-603-C (2004), *Land Mobile FM or PM Communications Equipment Measurement and Performance Standards*
 IC-GEN:2007 General Requirements and Information for the Certification of Radiocommunication Equipment

Test result: **Passed**

Date of issue:	19.04.2010			Signature:
Issue-No.:	01	Author:	M. Lehmann Test engineer	<i>[Handwritten signature]</i>
Date of delivery at ECL:	01.03.09	Checked:	M. Grytz Operational manager	
Test dates:	23.03. – 04.04.10	<i>[Handwritten signature]</i>		
Pages:	78			

EMC Test Report No.: 10-035

FCC ID: XS5-MR191919

IC ID: 2237E-MR191919



Manufacturer: ANDREW Wireless Systems GmbH
Industriering 10

D-86675 Buchdorf

Tel.: +49 (0)9099 69 0

Fax: +49 (0)9099 69 140

Test Location: TEMPTON Service Plus GmbH
European Compliance Laboratory (ECL)

Thurn-und Taxis-Straße 18

D-90411 Nürnberg

Tel.: +49 0911 59835 923

Fax: +49 0911 59835 90

General:

The purpose of this report is to show compliance to the FCC regulations for unlicensed devices operating under section 24 of the Code of Federal Regulations title 47.

This report informs about the results of the EMC tests, it only refers to the equipment under test. No part of this report may be reproduced in any form, without written permission.



Table of contents

1	TEST RESULTS SUMMARY	6
2	EQUIPMENT UNDER TEST (E.U.T.)	7
2.1	DESCRIPTION	7
2.1.1	DOWNLINK	7
2.1.2	UPLINK	7
2.1.3	DESCRIPTION OF EUT	7
2.1.4	SYSTEM DIAGRAMS	8
2.1.5	BLOCK DIAGRAM OF MEASUREMENT REFERENCE POINTS	9
3	TEST SITE (ANDREW BUCHDORF)	10
3.1	TEST ENVIRONMENT	10
3.2	TEST EQUIPMENT	10
3.3	INPUT AND OUTPUT LOSSES	10
3.4	MEASUREMENT UNCERTAINTY	10
4	TEST SITE (HERBERG)	11
5	RF POWER OUT: §24.232, §2.1046; RSS-133, RSS-GEN	12
5.1	LIMIT	12
5.1.1	FCC CFR47	12
5.1.2	IC RSS-133	12
5.2	TEST METHOD	13
5.2.1	FCC CFR47	13
5.2.2	IC RSS-GEN	13
5.3	TEST RESULTS	14
5.3.1	DOWNLINK	14
5.3.1.1	CDMA	16
5.3.1.2	W-CDMA	17
5.3.1.3	GSM	19
5.3.1.4	GSM-EDGE	20
5.3.2	UPLINK	22
5.3.2.1	CDMA	23
5.3.2.2	W-CDMA	24
5.3.2.3	GSM	26
5.3.2.4	GSM-EDGE	27
5.4	SUMMARY TEST RESULT	29
6	OCCUPIED BANDWIDTH: §2.1049; RSS-GEN	30
6.1	LIMIT	30
6.2	TEST METHOD	30
6.2.1	FCC CFR47	30
6.2.2	IC RSS-GEN	30
6.3	TEST RESULTS	31
6.3.1	DOWNLINK	31
6.3.1.1	CDMA	32



6.3.1.2	W-CDMA.....	33
6.3.1.3	GSM.....	34
6.3.1.4	GSM-EDGE	35
6.3.2	UPLINK	36
6.3.2.1	CDMA	37
6.3.2.2	W-CDMA.....	38
6.3.2.3	GSM.....	39
6.3.2.4	GSM-EDGE	40
6.4	SUMMARY TEST RESULT.....	41
7	SPURIOUS EMISSIONS AT ANTENNA TERMINALS: §24.238, §2.1051; RSS-132, RSS-GEN.....	42
7.1	LIMIT.....	42
7.1.1	FCC CFR47.....	42
7.1.2	IC RSS-133	42
7.2	TEST METHOD	43
7.2.1	FCC CFR47.....	43
7.2.2	IC RSS-GEN	43
7.3	TEST RESULTS	44
7.3.1	DOWNLINK	44
7.3.1.1	CDMA < 1MHz to band edge.....	45
7.3.1.2	W-CDMA < 1MHz to band edge	46
7.3.1.3	GSM < 1MHz to band edge	47
7.3.1.4	GSM-EDGE < 1MHz to band edge.....	48
7.3.1.5	CDMA > 1MHz to band edge.....	49
7.3.1.6	W-CDMA > 1MHz to band edge	49
7.3.1.7	GSM > 1MHz to band edge	50
7.3.1.8	GSM-EDGE > 1MHz to band edge.....	50
7.3.2	UPLINK	51
7.3.2.1	CDMA < 1MHz to band edge.....	52
7.3.2.2	W-CDMA < 1MHz to band edge	53
7.3.2.3	GSM < 1MHz to band edge	54
7.3.2.4	GSM-EDGE < 1MHz to band edge.....	55
7.3.2.5	CDMA > 1MHz to band edge.....	56
7.3.2.6	W-CDMA > 1MHz to band edge	56
7.3.2.7	GSM > 1MHz to band edge	57
7.3.2.8	GSM-EDGE > 1MHz to band edge.....	57
7.4	SUMMARY TEST RESULT.....	58
8	FIELD STRENGTH OF SPURIOUS EMISSIONS: §24.53, §2.1053	59
8.1	LIMIT §24.238.....	63
8.2	TEST METHOD ANSI/TIA/EA-603-C	63
8.3	CLIMATIC VALUES IN THE LAB.....	64
8.4	TEST RESULTS	65
8.4.1	PREMEASUREMENTS	65
8.4.1.1	30 MHz to 1 GHz Downlink (Bottom – Middle – Top).....	65
8.4.1.2	30 MHz to 1 GHz Uplink (Bottom – Middle – Top)	69
8.4.1.3	20 GHz -22 GHz Downlink (Bottom – Middle – Top).....	73
8.4.2	FINAL MEASUREMENTS	74
8.4.2.1	30 MHz to 1 GHz	74
8.4.2.2	0,8 GHz to 20GHz Downlink.....	74
8.4.2.3	0,8 GHz to 20GHz Uplink	76

EMC Test Report No.: 10-035

FCC ID: XS5-MR191919

IC ID: 2237E-MR191919



8.4.2.4	20GHz to 22GHz	77
8.5	SUMMARY TEST RESULT.....	77
9	HISTORY	78



1 Test Results Summary

Name of Test	FCC Para. No.	FCC Method	FCC Spec.	Result
RF Power Output	24.232(a)	2.1046(a)	160 Watts	Complies
Occupied Bandwidth		2.1049(h)	Input/Output	Complies
Spurious Emissions at Antenna Terminals	24.238(a)	2.1051	-13dBm	Complies
Field Strength of Spurious Emissions	24.238(a)	2.1053	-13dBm E.I.R.P	Complies
Frequency Stability		2.1055(a)(d)	Must stay in band	NA

Name of Test	IC Para. No.	IC Method	Result
RF Power Output	RSS-133 6.4	RSS-GEN 4.8	Complies
Occupied Bandwidth		RSS-GEN 4.6.1	Complies
Spurious Emissions at Antenna Terminals	RSS-133 6.5	RSS-GEN 4.9	Complies
Field Strength of Spurious Emissions			Complies
Frequency Stability	RSS-133 6.3	RSS-GEN 4.7	NA

Frequency stability is not applicable because the device uses a common oscillator to up convert and down convert the RF signal. The EUT does not contain modulation circuitry, or frequency generation, therefore the test was not performed.

2 Equipment under test (E.U.T.)

2.1 Description

Kind of equipment	MR1918/1918/1918 Repeater
Andrew Ident. Number	Id.No. 7613706
Serial no.(SN)	10
Revision	00
Software version and ID	V 2.1.0.3 Id.No.7612208-01
Type of modulation and Designator	CDMA (F9W) <input checked="" type="checkbox"/> W-CDMA (F9W) <input checked="" type="checkbox"/> GSM (GXW) <input checked="" type="checkbox"/> GSM-EDGE (G7W) <input checked="" type="checkbox"/>
Frequency Translation	F1-F1 <input checked="" type="checkbox"/> F1-F2 <input type="checkbox"/> N/A <input type="checkbox"/>
Band Selection	Software <input checked="" type="checkbox"/> Duplexer <input type="checkbox"/> Fullband <input type="checkbox"/>

2.1.1 Downlink

Pass band	1930 MHz – 1990 MHz
Max. composite output power based on one carrier (rated)	22,0 dBm = 158.5 mW
Gain max.	78dB

2.1.2 Uplink

Pass band	1850 MHz – 1910 MHz
Max. composite output power based on one carrier (rated)	22,0 dBm = 158.5 mW
Gain max.	78dB

2.1.3 Description of EUT

Andrew MR1918/1918/1918 is a minirepeater for indoor coverage in small areas.

The MR1918/1918/1918 consists of three equal 1900MHz paths (Segment 1, 2, 3), with the intended use of simultaneous transmission.

2.1.4 System diagrams

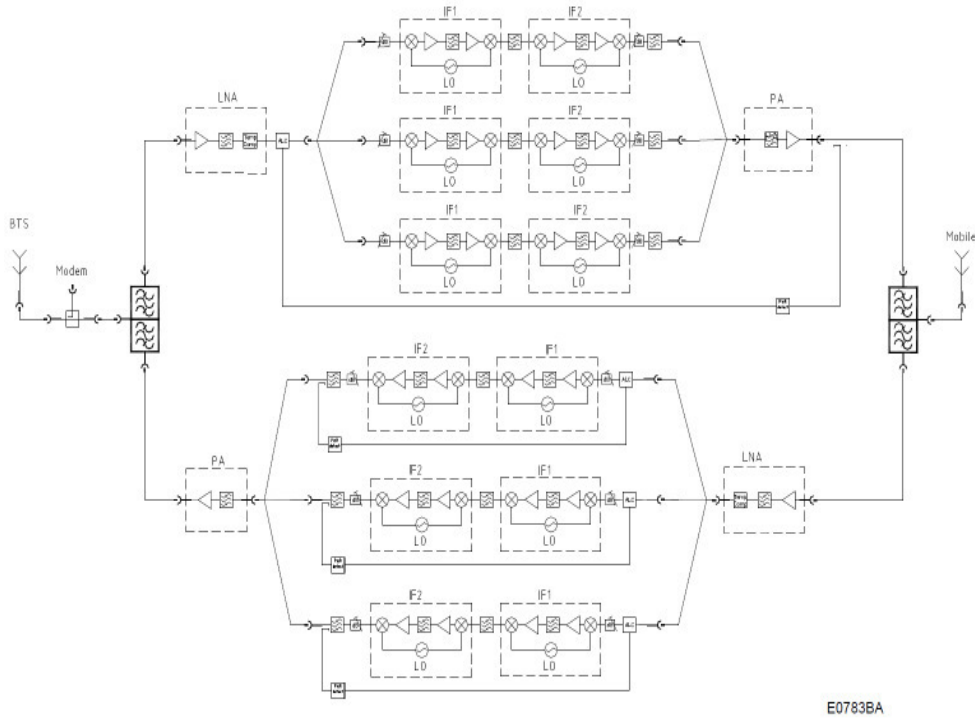

figure 2.1.4-#1 System diagrams: Minirepeater

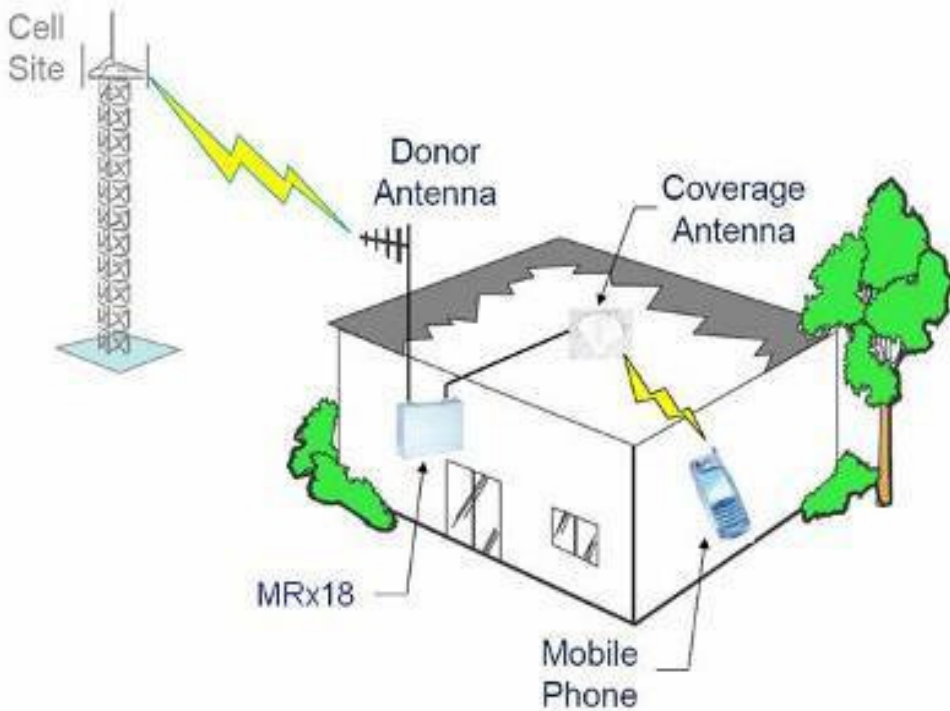

figure 2.1.4-#2 System diagrams: Application example

2.1.5 Block diagram of measurement reference points

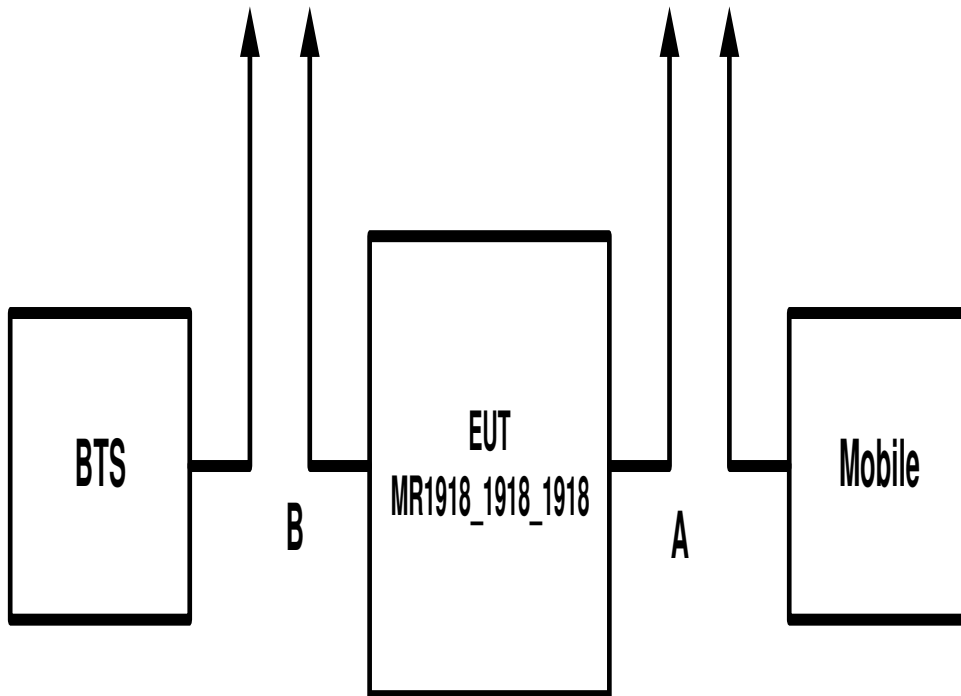

figure 2.1.5-#1 Block diagram of measurement reference points

Reference point A, Mobile: Repeater DL output, UL input
Reference point B, BTS: Repeater UL output, DL input

3 Test site (Andrew Buchdorf)

3.1 Test environment

All tests were performed under the following environmental conditions:

Condition	Minimum value	Maximum value
Barometric pressure	86 kPa	106 kPa
Temperature	15 °C	30 °C
Relative Humidity	20 %	75 %
Power supply range	±5% of rated voltages	

3.2 Test equipment

ANDREW Inv. No.	Test equipment	Type	Manufacturer	Serial No.	Calibration
8893	Network Analyzer	ZVB8	R&S	100201	06/10
8961	Spectrum Analyzer	FSP13	R&S	100147	10/10
8736	Spectrum Analyzer	FSIQ26	R&S	100290	04/10
8984	Signal Generator	E4438C	Agilent	MY45094089	11/10
8972	Signal Generator	SMIQ03B	R&S	837747/023	07/10
8686	Power Meter	E4418B	Agilent	MY41293484	09/10
8687	Power Sensor	E9300H	Agilent	MY41090294	09/10
7370	Automatic Box	Basic Part	Andrew	--	01/10
7119	Divider	2way	Mikom	3512	CIU
7323	Circulator	E10-1FFF	AEROTEK	25357	CIU
7315	Circulator	E10-1FFF	AEROTEK	25344	CIU
7363	RF-Cable	2,0m; N-N	Huber & Suhner	28439/4PEA	CIU
7295	RF-Cable	2,5m; N-N	Huber & Suhner	28964/4PEA	CIU
7299	RF-Cable	2,5m; N-N	Huber & Suhner	28964/4PEA	CIU
7364	RF-Cable	1,0m; SMA	Huber & Suhner	36309/4P	CIU
7365	RF-Cable	1,0m; SMA	Huber & Suhner	36292/4P	CIU
7366	RF-Cable	2,0m; SMA	Huber & Suhner	36183/4P	CIU
7367	RF-Cable	2,0m; SMA	Huber & Suhner	36158/4P	CIU
7373	RF-Cable	Multiflex141 0,6m	Andrew	---	CIU
7374	RF-Cable	Multiflex141 0,6m	Andrew	---	CIU

CIU = Calibrate in use

3.3 Input and output losses

All recorded power levels should be referenced to the input and output connectors of the repeater, unless explicitly stated otherwise.

The test equipment used in this test has to be calibrated, so that the functionality is also checked.

All cables, attenuators, splitter, isolator, circulator and combiner etc. must be measured before testing and used for compensation during testing.

3.4 Measurement uncertainty

The extended measurement uncertainty corresponds to the measurement results from the standard measurement uncertainty multiplied by the coverage factor $k=2$. The true value is located in the corresponding interval with a probability of 95 %.

EMC Test Report No.: 10-035

FCC ID: XS5-MR191919

IC ID: 2237E-MR191919



4 Test site (TEMPTON)

FCC Test site: 96997
IC OATS: IC3475A-1

See relevant data under section 8 of this test report.



5 RF Power Out: §24.232, §2.1046; RSS-133, RSS-GEN

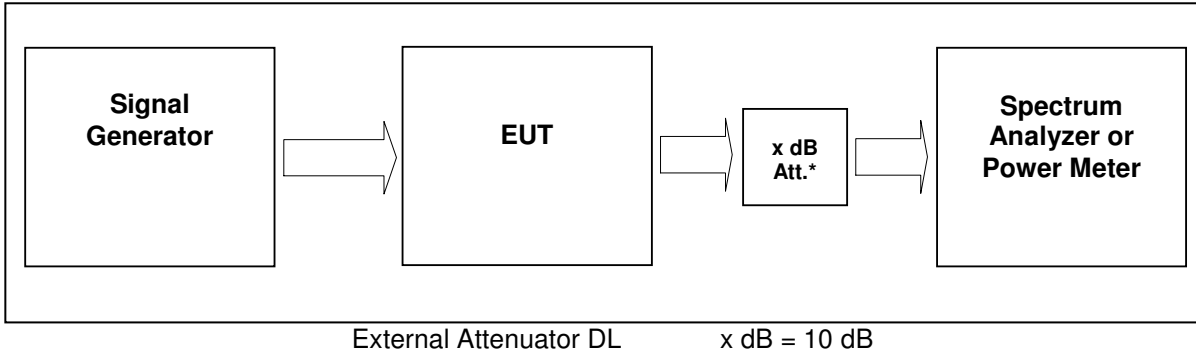

figure 3.4-#1 Test setup: RF Power Out: §24.232, §2.1046; RSS-133, RSS-GEN

Measurement uncertainty	± 0,38 dB
Test equipment used	8984,8686,8687,8961,7370

5.1 Limit

5.1.1 FCC CFR47

Minimum standard:

Para. No.24.232(a)

a) Base stations are limited to 1640 watts peak equivalent isotropically radiated power (EIRP) with an antenna height up to 300 meters HAAT, except as described in paragraph (b) below. See §24.53 for HAAT calculation method. Base station antenna heights may exceed 300 meters with a corresponding reduction in power; see Table 1 of this section. The service area boundary limit and microwave protection criteria specified in §§24.236 and 24.237 apply.

Table 1—Reduced Power for Base Station Antenna Heights Over 300 Meters

HAAT in meters	Maximum EIRP watts
≤ 300	1640
≤ 500	1070
≤ 1000	490
≤ 1500	270
≤ 2000	160

5.1.2 IC RSS-133

6.4 Transmitter Output Power

The average equivalent isotropically radiated power (e.i.r.p.) for transmitters shall not exceed the limits given in SRSP-510. Moreover, base station transmitters operating in the band 1930-1995 MHz shall not have output power exceeding 100 watts.

In addition, when the transmitter power is measured in terms of average value, the peak-to-average ratio of the power shall not exceed 13 dB.



5.2 Test method

5.2.1 FCC CFR47

§ 2.1046 Measurements required: RF power output.

(a) For transmitters other than single sideband, independent sideband and controlled carrier radiotelephone, power output shall be measured at the RF output terminals when the transmitter is adjusted in accordance with the tune-up procedure to give the values of current and voltage on the circuit elements specified in § 2.1033(c)(8). The electrical characteristics of the radio frequency load attached to the output terminals when this test is made shall be stated.

(c) For measurements conducted pursuant to paragraphs (a) and (b) of this section, all calculations and methods used by the applicant for determining carrier power or peak envelope power, as appropriate, on the basis of measured power in the radio frequency load attached to the transmitter output terminals shall be shown. Under the test conditions specified, no components of the emission spectrum shall exceed the limits specified in the applicable rule parts as necessary for meeting occupied bandwidth or emission limitations

5.2.2 IC RSS-GEN

4.8 Transmitter Output Power

Transmitter output power measurements shall be carried out before the unwanted emissions test. The transmitter output power value, obtained from this test, serves as the reference level used to determine the unwanted emissions. For comparative purposes, the measurements of emission power and unwanted emissions can be in peak or average provided the same parameter is used when measuring both. This information shall be included in the test report.

If the transmission is in bursts, the output power shall be averaged over any 100 millisecond period or, over the burst duration if the burst is shorter than 100 milliseconds, during which its value is at its maximum. The power shall only be averaged over the duration of actual transmission. No off times are to be included in the average.

If the RF output power is internally or externally adjustable or remotely controllable, set or control the power to the maximum rating of the range for which equipment certification is sought. If the spectrum analyzer selectivity or bandwidth is insufficient when measuring emission power, a resolution bandwidth, narrower than that specified, plus numerical integration, in terms of linear power to sum the transmitter output power, is permitted. The method used shall be described in the test report.

If the antenna is detachable, the transmitter output power may be measured at the antenna port using conducted measurement.

If the antenna is not detachable, field strength measurements shall be made using a calibrated open area test site.

The following formula may be used to convert field strength (FS) in volts/metre to transmitter output power (TP) in watts:

$$TP = (FS \times D)^2 / (30 \times G)$$

Where D is the distance in metres between the two antennas and G is the antenna numerical gain referenced to isotropic gain. (Note: In an open-area test measurement, the effect due to the metal ground plane should be subtracted from the maximum field strength value in order to reference it to free space, before calculating TP.)

Measure and record the transmitter output power using a measurement bandwidth at least 3 times the emission bandwidth of the transmitter, or use power summation as described above.

5.3 Test results

Detector RMS.

Test signal GSM:

Signal waveform with GMSK modulation in all time slots according to 3GPP TS45.004

Test signal GSM EDGE:

Signal waveform with 8-PSK modulation in all time slots according to 3GPP TS45.004

Test signal CDMA2000:

Signal waveform according to table 6.2-1 of standard specification 3GPP2 C.p0051-0 v1.0

16.February 2006 pilot, sync, paging, 37 traffics, which is equal to the table 6.5.2.1 of 3GPP2 C.S0010-C v2.0 24.February 2006.

Test signal WCDMA:

Signal waveform according to Test Model 1 clause 6.1.1.1 of standard specification 3GPP TS25.141 v8.8.0 (2009-09). Signal modulated with a combination of PCCPCH, SCCPCH and Dedicated Physical Channels specified as test model 1 64 DPCH.

According to ANSI C63.4 section 13.1 Table 5 for operating frequencies more then 10MHz: The test shall be performed at Bottom, Middle, Top frequencies.

5.3.1 Downlink

Modulation	Measured at		RBW VBW Span	RF Power (dBm)	RF Power (W)	Plot -
CDMA	Bottom	1930,625 MHz	3MHz	22.5	0.141	5.3.1.1 #1
	Middle	1960,00 MHz	10MHz	22.0	0.159	#2
	Top	1989,375 MHz	15MHz	21.3	0.135	#3
WCDMA	Bottom	1932,4 MHz	10MHz	17.5	0.057	5.3.1.2 #1
	Middle	1960,4 MHz	10MHz	18.1	0.063	#2
	Top	1987,4 MHz	50MHz	17.4	0.055	#3
GSM	Bottom	1930,1 MHz	1MHz	21.8	0.151	5.3.1.3 #1
	Middle	1960,0 MHz	3MHz	22.1	0.162	#2
	Top	1989,9 MHz	2MHz	21.8	0.151	#3
GSM- EDGE	Bottom	1930,1 MHz	1MHz	21.9	0.155	5.3.1.4 #1
	Middle	1960,0 MHz	3MHz	22.1	0.162	#2
	Top	1989,9 MHz	2MHz	21.9	0.155	#3
Maximum output power = 22 dBm -> 0.159 W						
Limit Maximum output power = 160 W -> 52,04 dBm						

table 5.3.1-#1 RF Power Out: §24.232, §2.1046; RSS-133, RSS-GEN Test results Downlink

EMC Test Report No.: 10-035

FCC ID: XS5-MR191919

IC ID: 2237E-MR191919



Modulation	Pin / dBm (Ref. point B)
CDMA GSM, GSM-EDGE	-56
WCDMA	-60

table 5.3.1-#2 RF Power Out: §24.232, §2.1046; RSS-133, RSS-GEN Test results Downlink Input power



5.3.1.1 CDMA

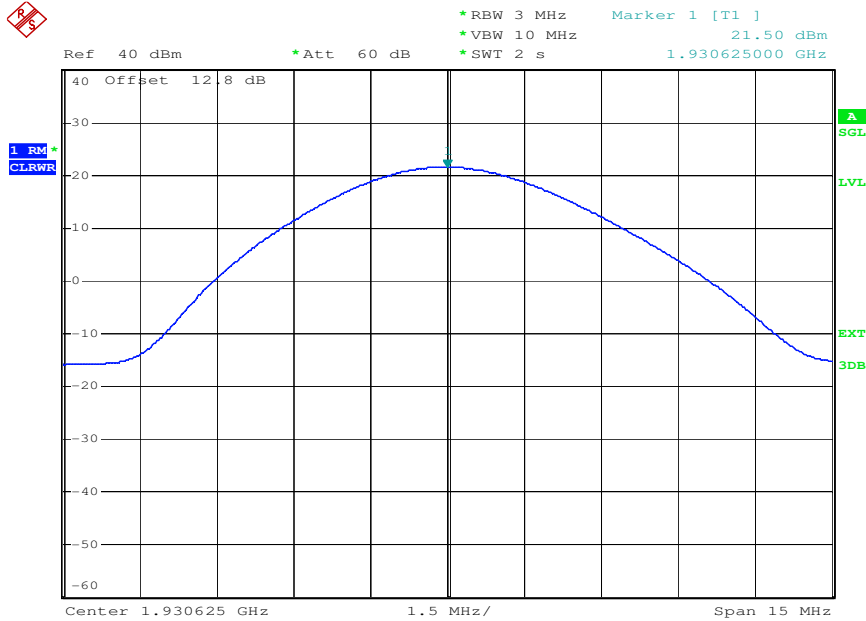

Date: 22.FEB.2010 14:51:56

plot 5.3.1.1-#1 RF Power Out: §24.232, §2.1046; RSS-133, RSS-GEN; Test results; Downlink; CDMA Bottom

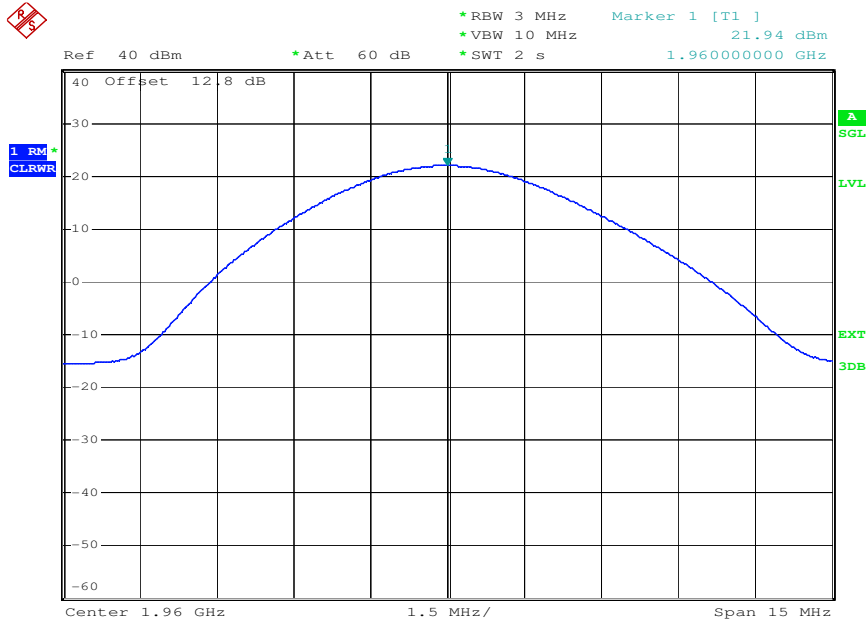

Date: 22.FEB.2010 14:52:26

plot 5.3.1.1-#2 RF Power Out: §24.232, §2.1046; RSS-133, RSS-GEN; Test results; Downlink; CDMA Middle

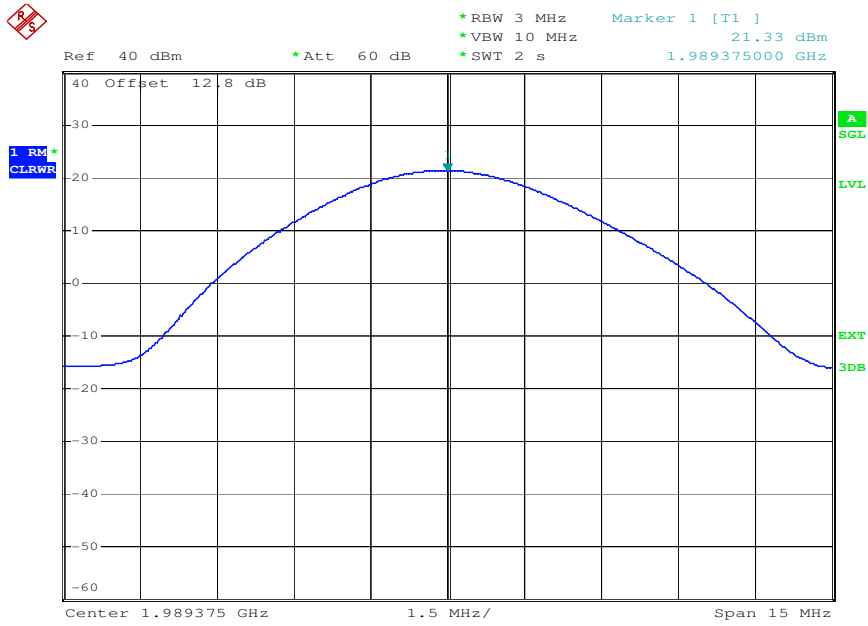

Date: 22.FEB.2010 14:52:55

plot 5.3.1.1-#3 RF Power Out: §24.232, §2.1046; RSS-133, RSS-GEN; Test results; Downlink; CDMA Top

5.3.1.2 W-CDMA

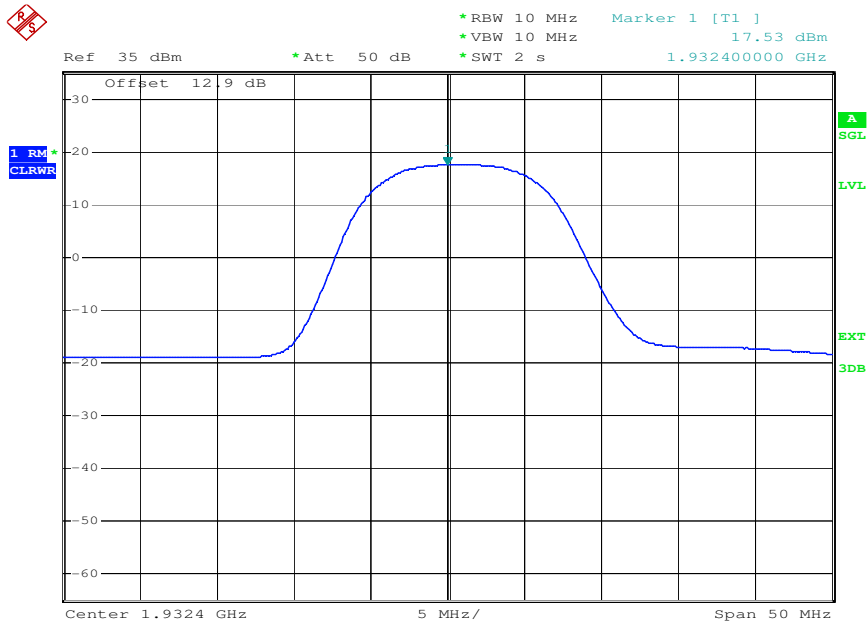

Date: 22.FEB.2010 16:29:38

plot 5.3.1.2-#1 RF Power Out: §24.232, §2.1046; RSS-133, RSS-GEN; Test results; Downlink; W-CDMA Bottom

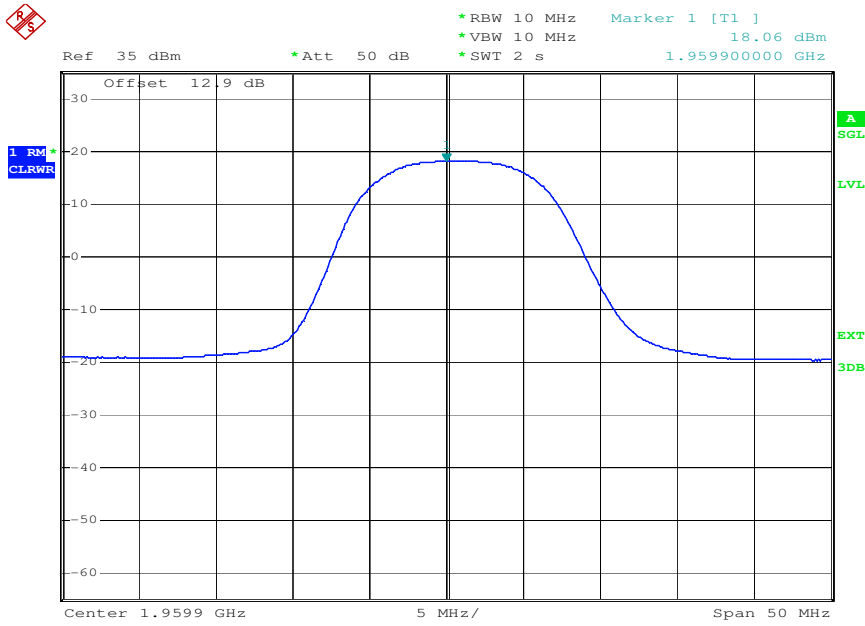

Date: 22.FEB.2010 16:30:04

plot 5.3.1.2-#2 RF Power Out: §24.232, §2.1046; RSS-133, RSS-GEN; Test results; Downlink; W-CDMA Middle

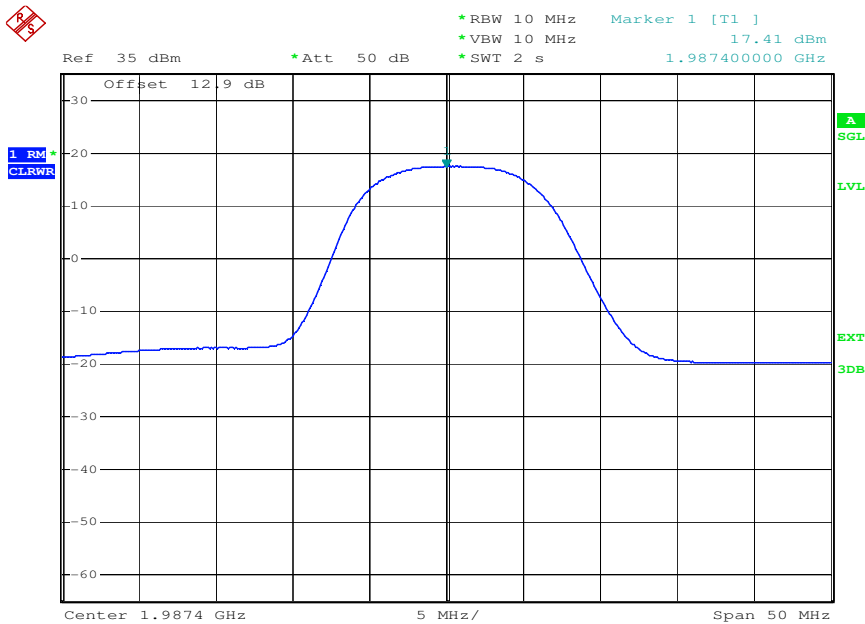

Date: 22.FEB.2010 16:30:30

plot 5.3.1.2-#3 RF Power Out: §24.232, §2.1046; RSS-133, RSS-GEN; Test results; Downlink; W-CDMA Top



5.3.1.3 GSM

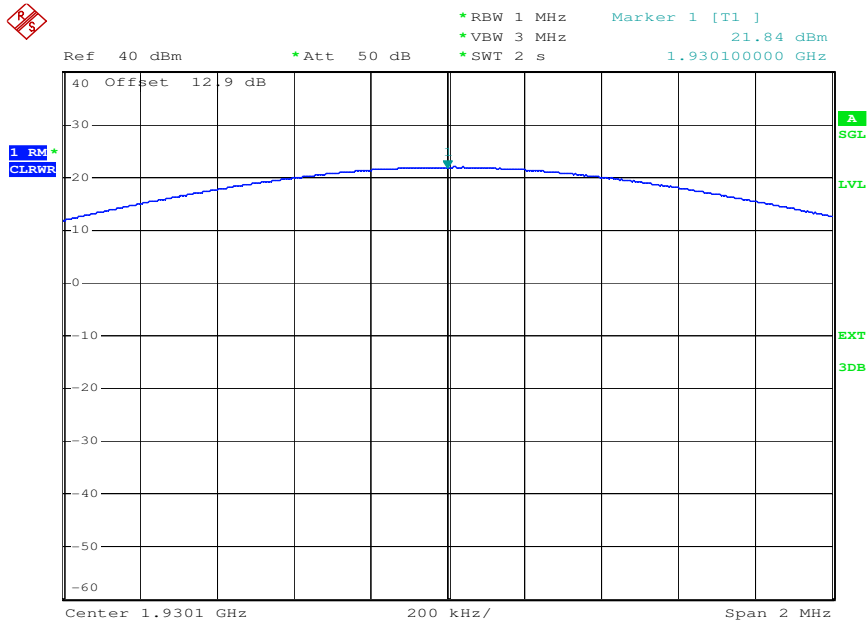

Date: 23.FEB.2010 15:33:38

plot 5.3.1.3-#1 RF Power Out: §24.232, §2.1046; RSS-133, RSS-GEN; Test results; Downlink; GSM Bottom

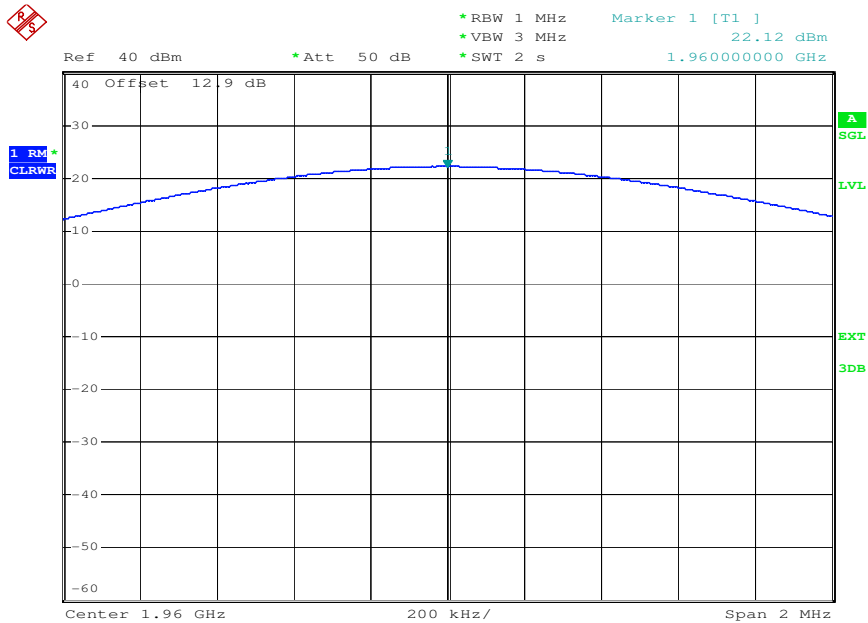

Date: 23.FEB.2010 15:34:04

plot 5.3.1.3-#2 RF Power Out: §24.232, §2.1046; RSS-133, RSS-GEN; Test results; Downlink; GSM Middle

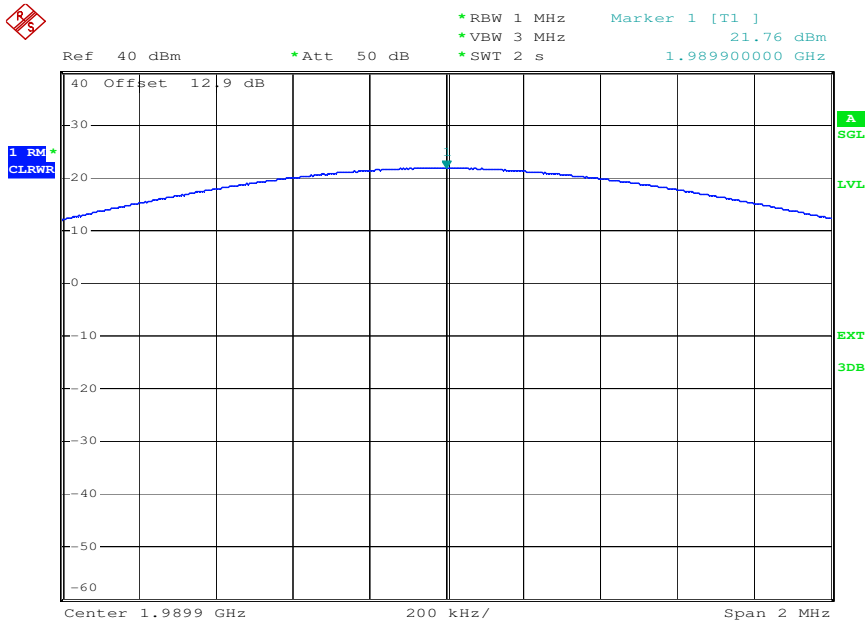

Date: 23.FEB.2010 15:34:30

plot 5.3.1.3-#3 RF Power Out: §24.232, §2.1046; RSS-133, RSS-GEN; Test results; Downlink; GSM Top

5.3.1.4 GSM-EDGE

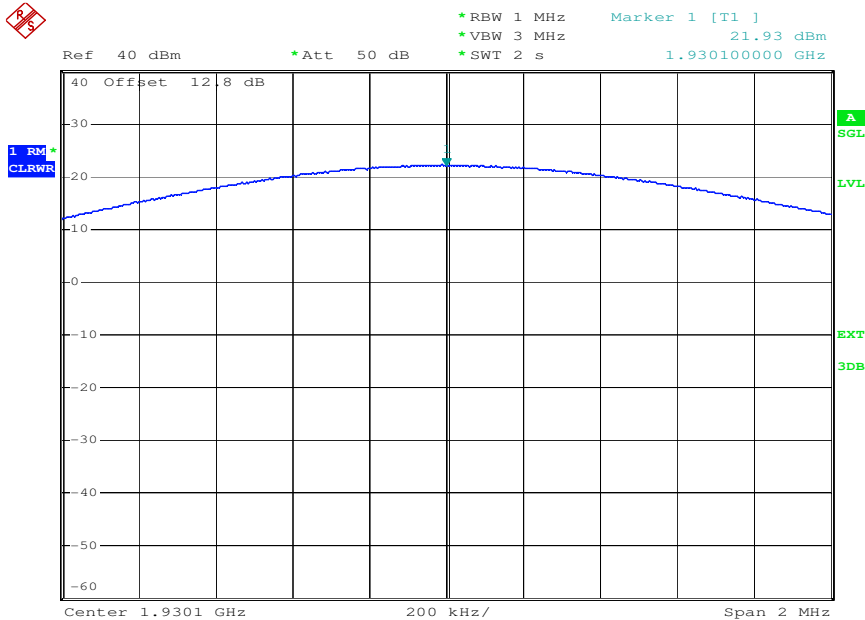

Date: 23.FEB.2010 16:22:02

plot 5.3.1.4-#1 RF Power Out: §24.232, §2.1046; RSS-133, RSS-GEN; Test results; Downlink; GSM-EDGE Bottom

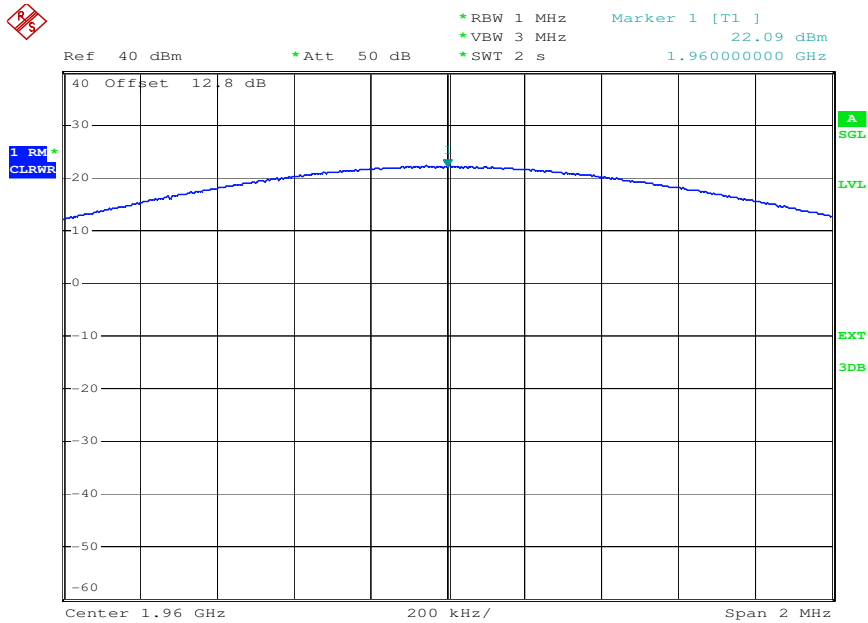

Date: 23.FEB.2010 16:22:28

plot 5.3.1.4-#2 RF Power Out: §24.232, §2.1046; RSS-133, RSS-GEN; Test results; Downlink; GSM-EDGE Middle

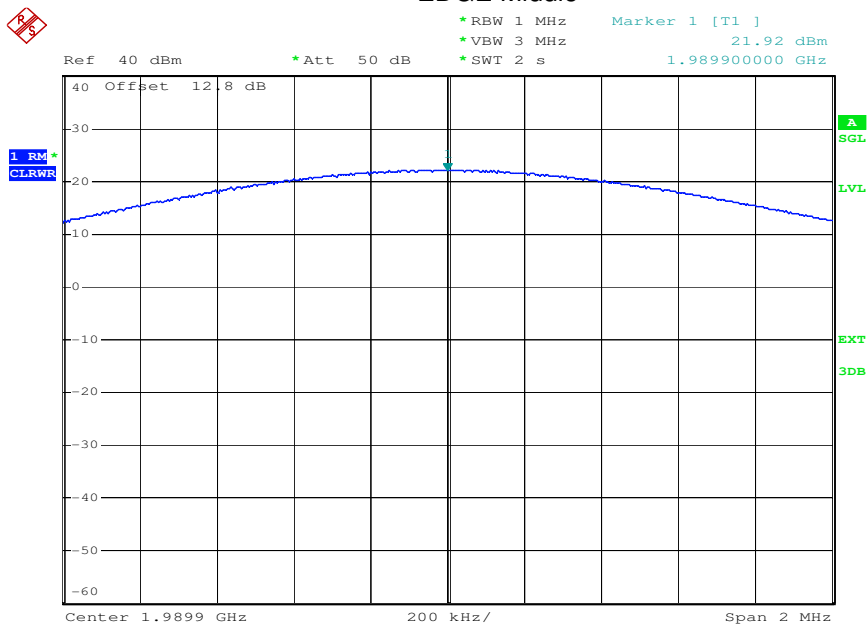

Date: 23.FEB.2010 16:22:54

plot 5.3.1.4-#3 RF Power Out: §24.232, §2.1046; RSS-133, RSS-GEN; Test results; Downlink; GSM-EDGE Top



5.3.2 Uplink

Modulation	Measured at		RBW VBW Span	RF Power (dBm)	RF Power (W)	Plot -
CDMA	Bottom	1850,625 MHz	3MHz	22.0	0.159	5.3.2.1 #1
	Middle	1880,00 MHz	10MHz	22.0	0.159	#2
	Top	1909,375 MHz	15MHz	21.8	0.151	#3
WCDMA	Bottom	1852,4 MHz	10MHz	18.0	0.063	5.3.2.2 #1
	Middle	1882,4 MHz	10MHz	18.0	0.063	#2
	Top	1907,4 MHz	50MHz	17.4	0.055	#3
GSM	Bottom	1850,1 MHz	1MHz	22.1	0.162	5.3.2.3 #1
	Middle	1880,0 MHz	3MHz	22.0	0.159	#2
	Top	1909,9 MHz	2MHz	22.0	0.159	#3
GSM-EDGE	Bottom	1850,1 MHz	1MHz	22.0	0.159	5.3.2.4 #1
	Middle	1880,0 MHz	3MHz	22.0	0.159	#2
	Top	1909,9 MHz	2MHz	22.1	0.162	#3
Maximum output power = 22 dBm -> 0.159 W						
Limit Maximum output power = 160 W -> 52,04 dBm						

table 5.3.2-#3 RF Power Out: §24.232, §2.1046; RSS-133, RSS-GEN Test results Uplink

Modulation	Pin / dBm (Ref. point A)
CDMA GSM, GSM-EDGE	-56
WCDMA	-60

table 5.3.2-#4 RF Power Out: §24.232, §2.1046; RSS-133, RSS-GEN Test results Uplink Input power



5.3.2.1 CDMA

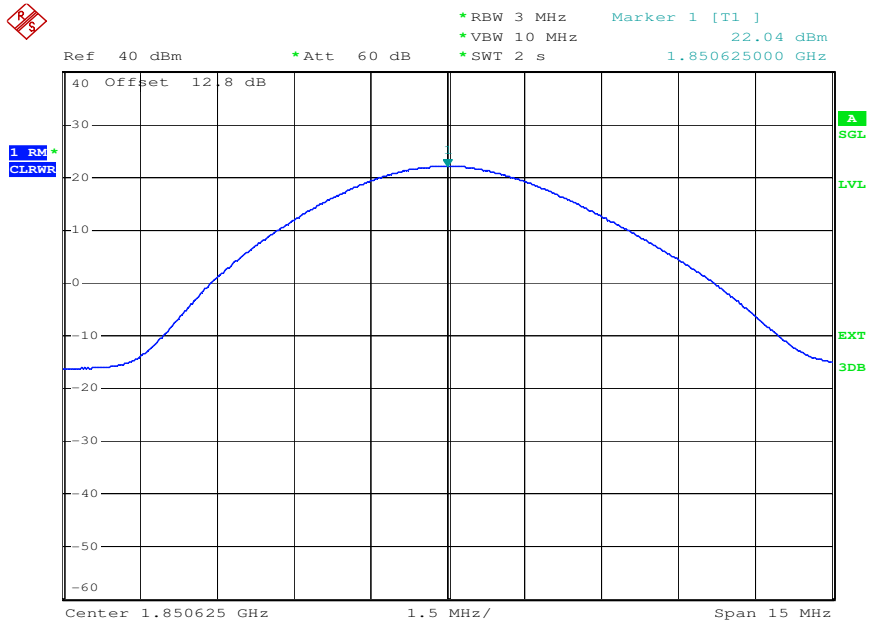

Date: 22.FEB.2010 14:53:24

plot 5.3.2.1-#1 RF Power Out: §24.232, §2.1046; RSS-133, RSS-GEN; Test results; Uplink; CDMA Bottom

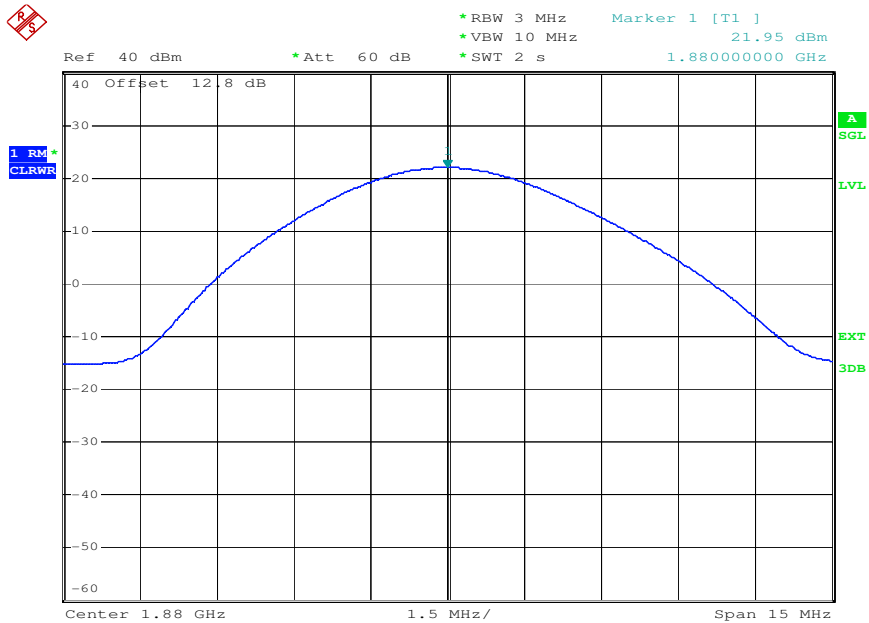

Date: 22.FEB.2010 14:53:53

plot 5.3.2.1-#2 RF Power Out: §24.232, §2.1046; RSS-133, RSS-GEN; Test results; Uplink; CDMA Middle

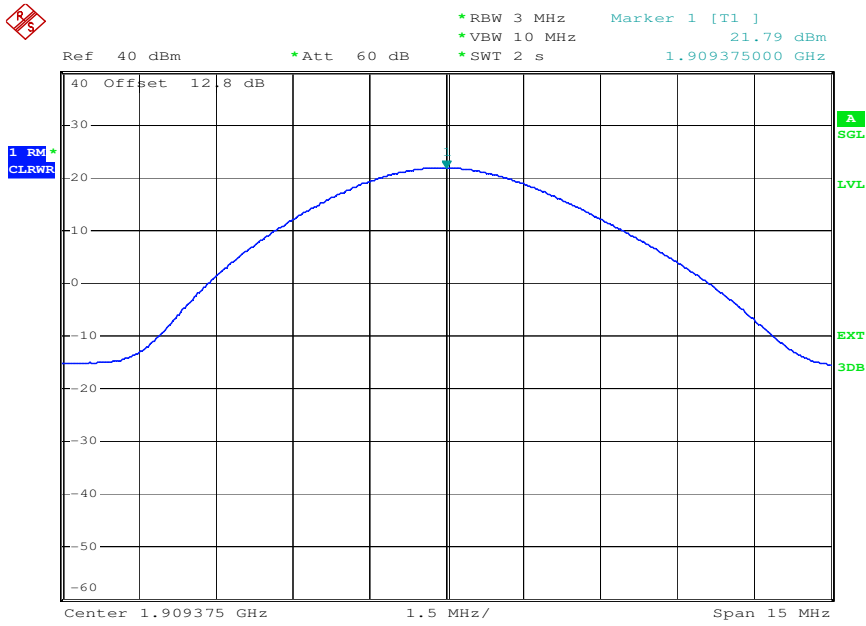

Date: 22.FEB.2010 14:54:22

plot 5.3.2.1-#3 RF Power Out: §24.232, §2.1046; RSS-133, RSS-GEN; Test results; Uplink; CDMA Top

5.3.2.2 W-CDMA

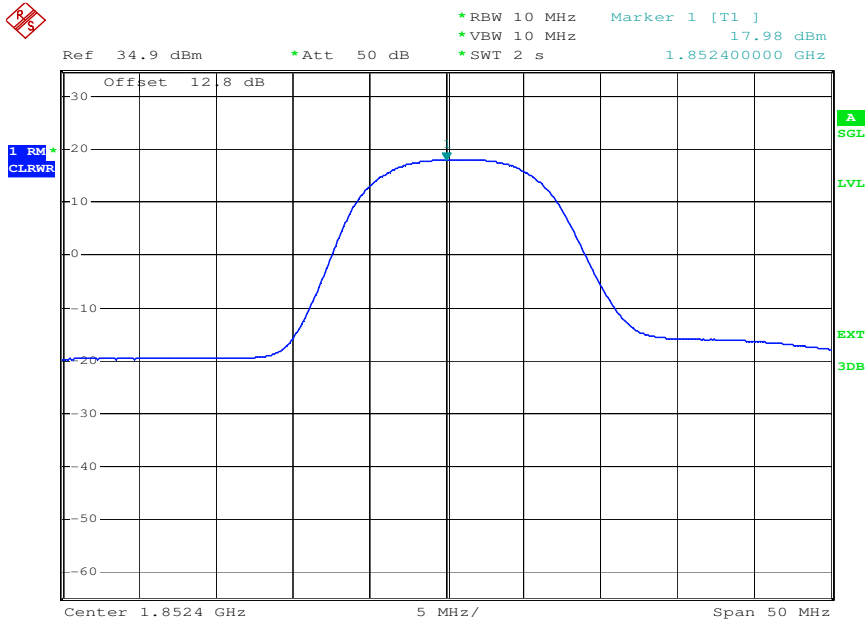

Date: 22.FEB.2010 16:30:56

plot 5.3.2.2-#1 RF Power Out: §24.232, §2.1046; RSS-133, RSS-GEN; Test results; Uplink; W-CDMA Bottom

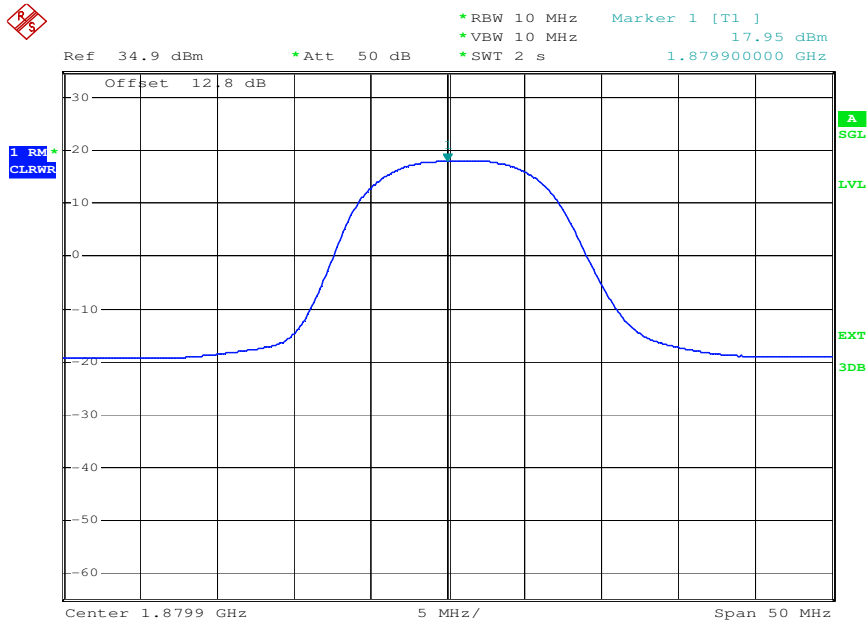

Date: 22.FEB.2010 16:31:22

plot 5.3.2.2-#2 RF Power Out: §24.232, §2.1046; RSS-133, RSS-GEN; Test results; Uplink; W-CDMA Middle

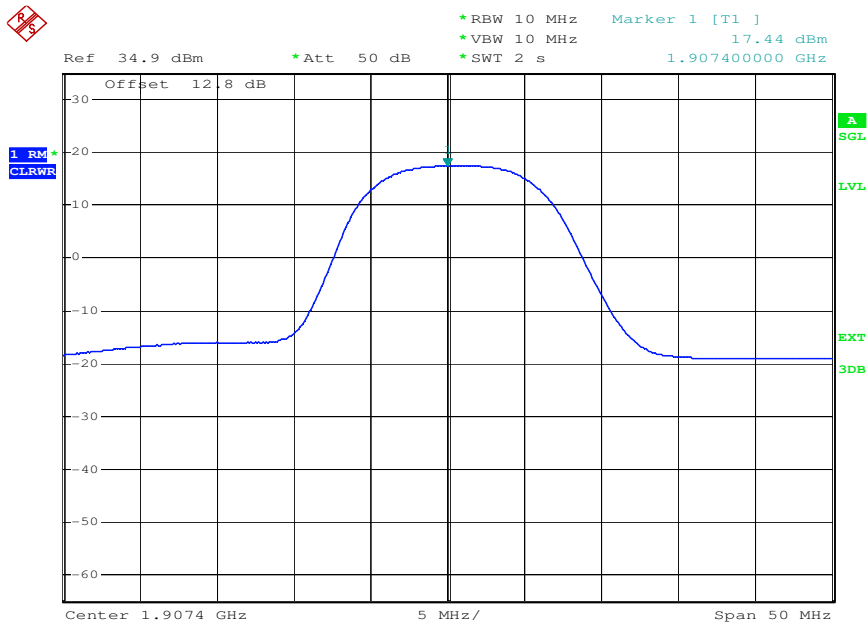

Date: 22.FEB.2010 16:31:48

plot 5.3.2.2-#3 RF Power Out: §24.232, §2.1046; RSS-133, RSS-GEN; Test results; Uplink; W-CDMA Top



5.3.2.3 GSM

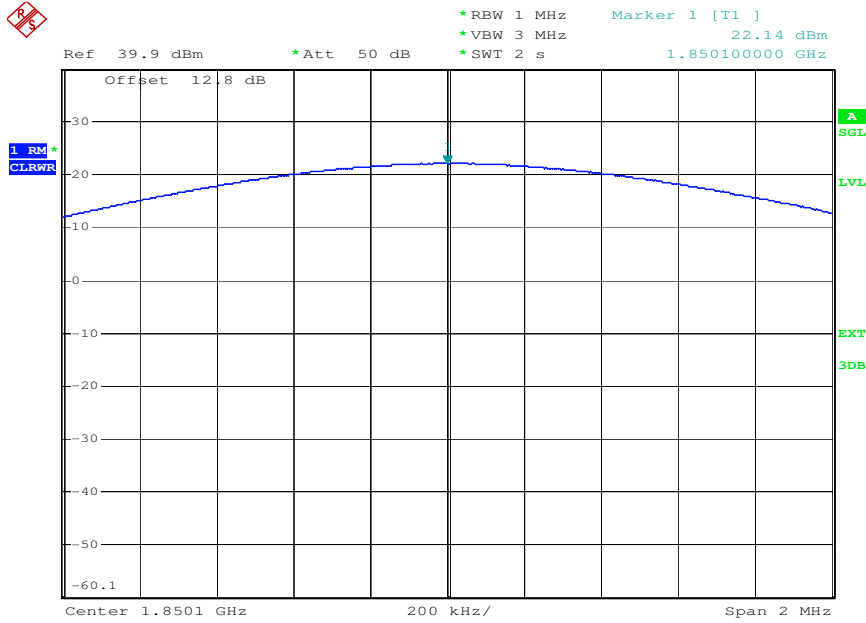

Date: 23.FEB.2010 15:34:56

plot 5.3.2.3-#1 RF Power Out: §24.232, §2.1046; RSS-133, RSS-GEN; Test results; Uplink; GSM Bottom

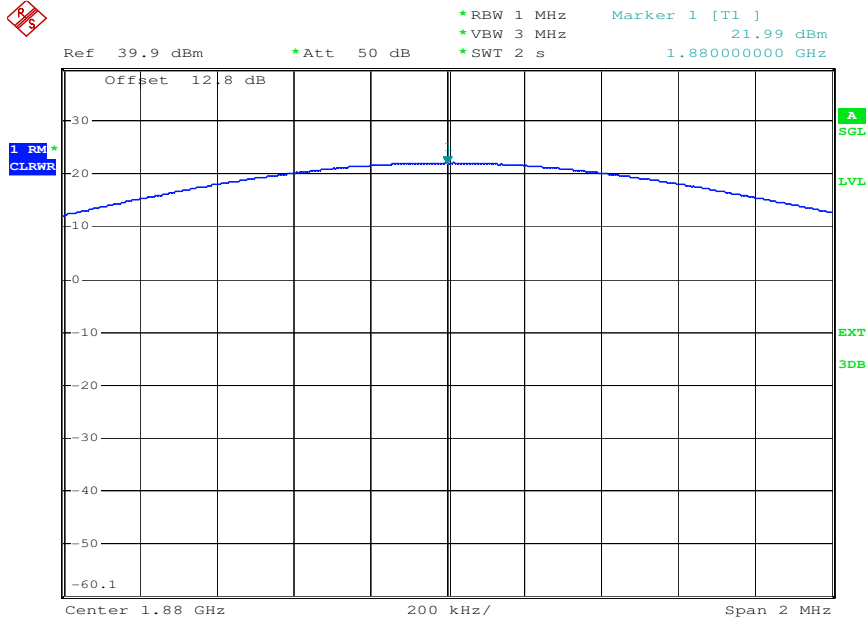

Date: 23.FEB.2010 15:35:22

plot 5.3.2.3-#2 RF Power Out: §24.232, §2.1046; RSS-133, RSS-GEN; Test results; Uplink; GSM Middle

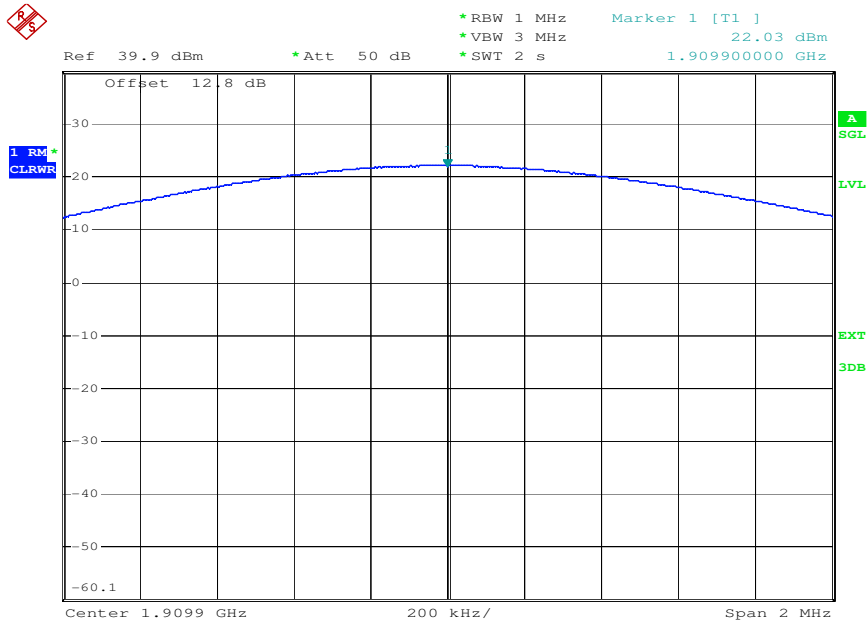

Date: 23.FEB.2010 15:35:48

plot 5.3.2.3-#3 RF Power Out: §24.232, §2.1046; RSS-133, RSS-GEN; Test results; Uplink; GSM Top

5.3.2.4 GSM-EDGE

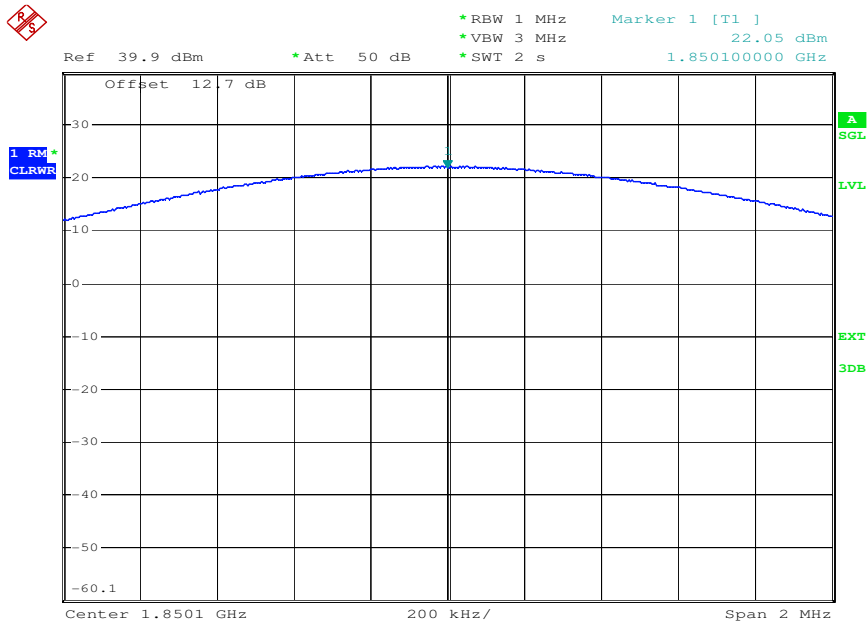

Date: 23.FEB.2010 16:23:21

plot 5.3.2.4-#1 RF Power Out: §24.232, §2.1046; RSS-133, RSS-GEN; Test results; Uplink; GSM-EDGE Bottom

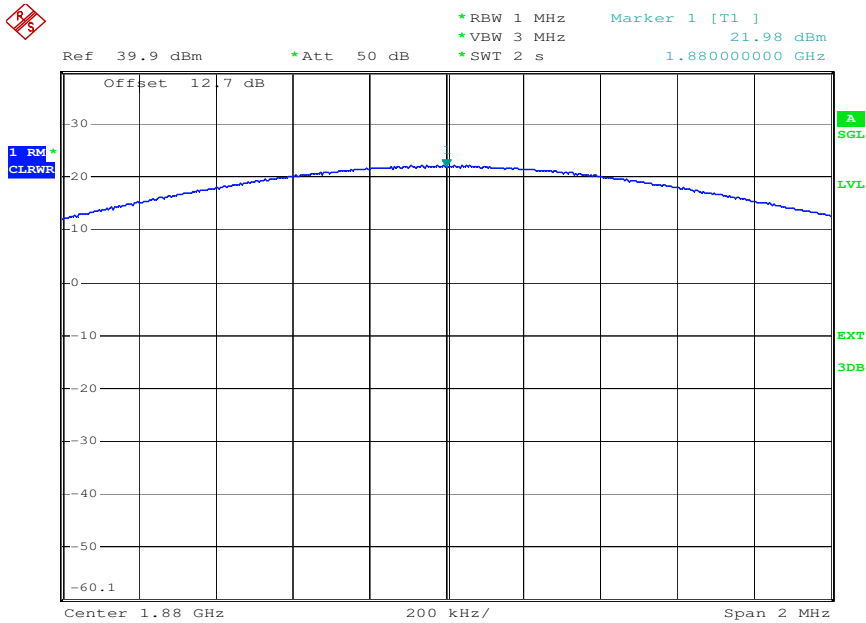

Date: 23.FEB.2010 16:23:47

plot 5.3.2.4-#2 RF Power Out: §24.232, §2.1046; RSS-133, RSS-GEN; Test results; Uplink; GSM-EDGE Middle

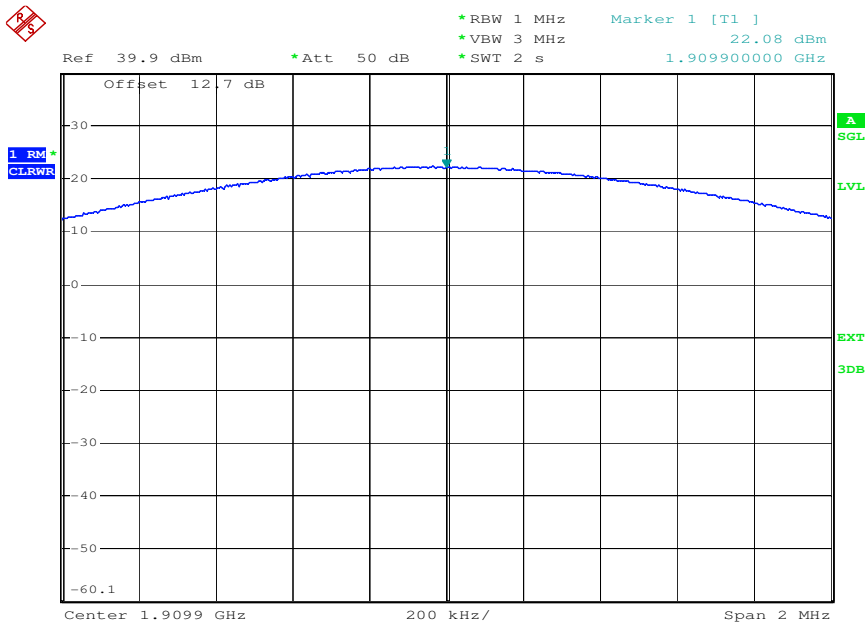

Date: 23.FEB.2010 16:24:13

plot 5.3.2.4-#3 RF Power Out: §24.232, §2.1046; RSS-133, RSS-GEN; Test results; Uplink; GSM-EDGE Top

EMC Test Report No.: 10-035

FCC ID: XS5-MR191919

IC ID: 2237E-MR191919



5.4 Summary test result

Test result	complies, according the plots above
Tested by:	Roland Macho
Date:	23.02.2010

6 Occupied Bandwidth: §2.1049; RSS-GEN

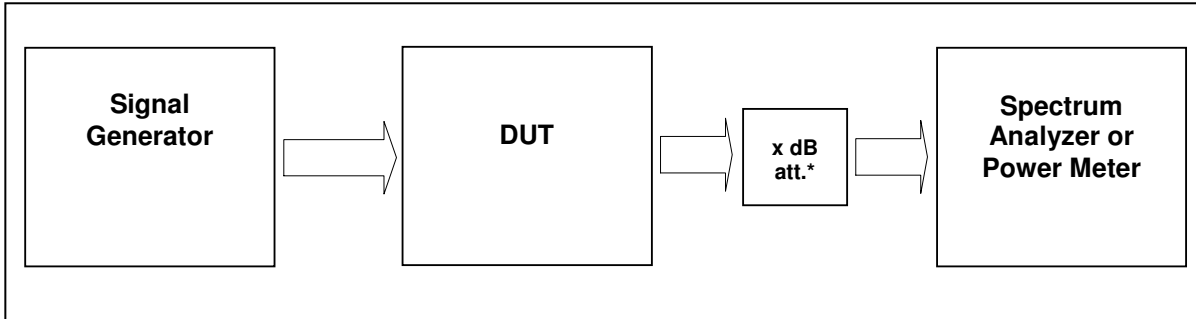

External Attenuator DL x dB = 10 dB
figure 5.4-#1 Test setup: Occupied Bandwidth: §2.1049; RSS-GEN

Measurement uncertainty	± 0,38 dB
Test equipment used	8984,8686,8687,8961,7370

6.1 Limit

The spectral shape of the output should look similar to input for all modulations.

6.2 Test method

6.2.1 FCC CFR47

Para. No.2.1049

The occupied bandwidth, that is the frequency bandwidth such that, below its lower and above its upper frequency limits, the mean powers radiated are each equal to 0.5 percent of the total mean power radiated by a given emission shall be measured under the following conditions as applicable:

(h) Transmitters employing digital modulation techniques—when modulated by an input signal such that its amplitude and symbol rate represent the maximum rated conditions under which the equipment will be operated. The signal shall be applied through any filter networks, pseudo-random generators or other devices required in normal service. Additionally, the occupied bandwidth shall be shown for operation with any devices used for modifying the spectrum when such devices are optional at the discretion of the user.

6.2.2 IC RSS-GEN

4.6.1 Occupied Bandwidth

When an occupied bandwidth value is not specified in the applicable RSS, the transmitted signal bandwidth to be reported is to be its 99% emission bandwidth, as calculated or measured.

The transmitter shall be operated at its maximum carrier power measured under normal test conditions.

The span of the analyzer shall be set to capture all products of the modulation process, including the emission skirts. The resolution bandwidth shall be set to as close to 1% of the selected span as is possible without being below 1%. The video bandwidth shall be set to 3 times the resolution bandwidth. Video averaging is not permitted. Where practical, a sampling detector shall be used since a peak or, peak hold, may produce a wider bandwidth than actual.

The trace data points are recovered and are directly summed in linear terms. The recovered amplitude data points, beginning at the lowest frequency, are placed in a running sum until 0.5% of the total is

reached and that frequency recorded. The process is repeated for the highest frequency data points. This frequency is recorded.

The span between the two recorded frequencies is the occupied bandwidth.

6.3 Test results

6.3.1 Downlink

Detector: RMS.

Modulation	Measured at		RBW VBW Span	Occupied Bandwidth / MHz	Plot #
CDMA	Middle	1960,0 MHz	30kHz 300kHz 5MHz	1.27	6.3.1.1 #1, #2
WCDMA	Middle	1960,0 MHz	100kHz 1MHz 10MHz	4.20	6.3.1.2 #1, #2
GSM	Middle	1960,0 MHz	3kHz 30kHz 1MHz	0.248	6.3.1.3 #1, #2
GSM-EDGE	Middle	1960,0 MHz	3kHz 30kHz 1MHz	0.248	6.3.1.4 #1, #2

table 6.3-#1 Occupied Bandwidth: §2.1049; RSS-GEN Test results Downlink



6.3.1.1 CDMA

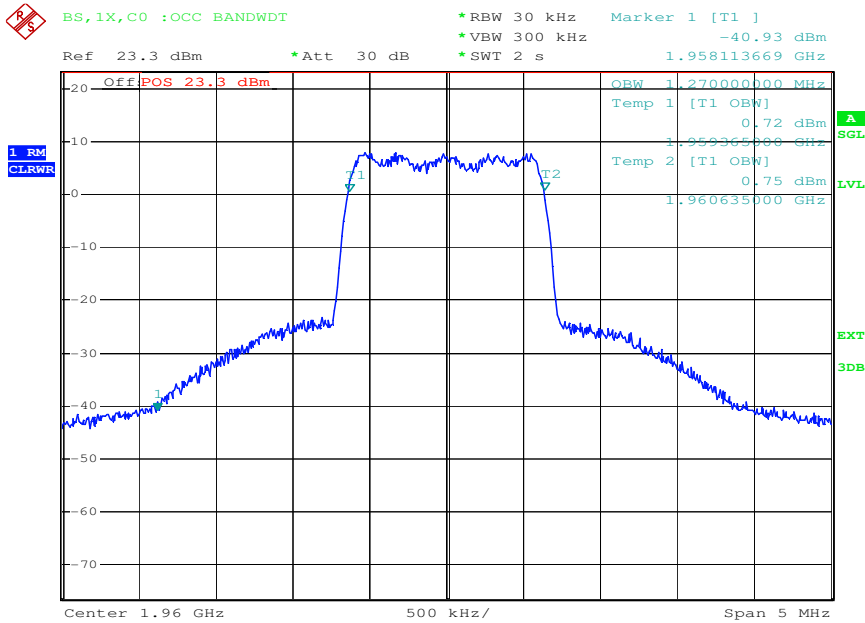

Date: 11.MAR.2010 14:03:32

plot 6.3.1.1-#1 Occupied Bandwidth: \$2.1049; RSS-GEN; Test results; Downlink; CDMA Output

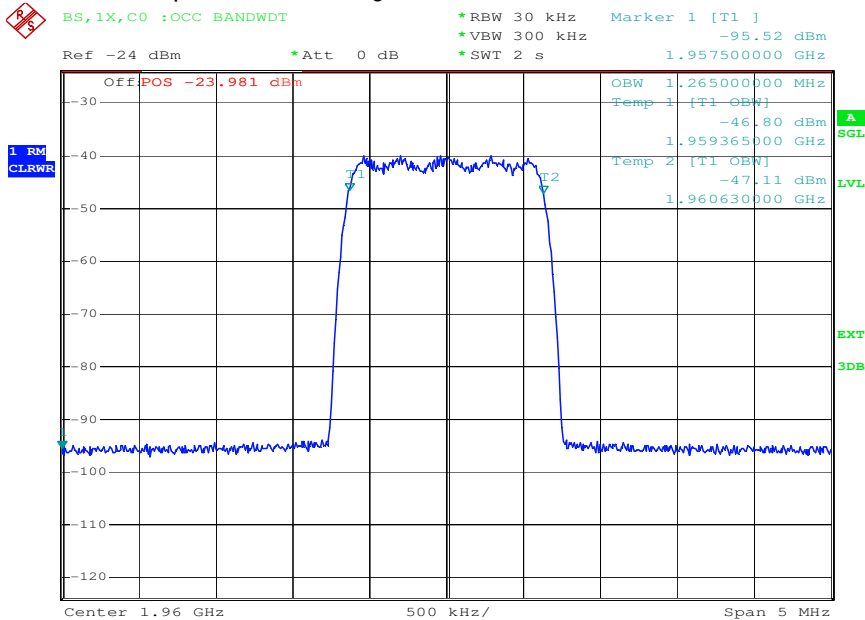

Date: 11.MAR.2010 14:09:02

plot 6.3.1.1-#2 Occupied Bandwidth: \$2.1049; RSS-GEN; Test results; Downlink; CDMA Input



6.3.1.2 W-CDMA

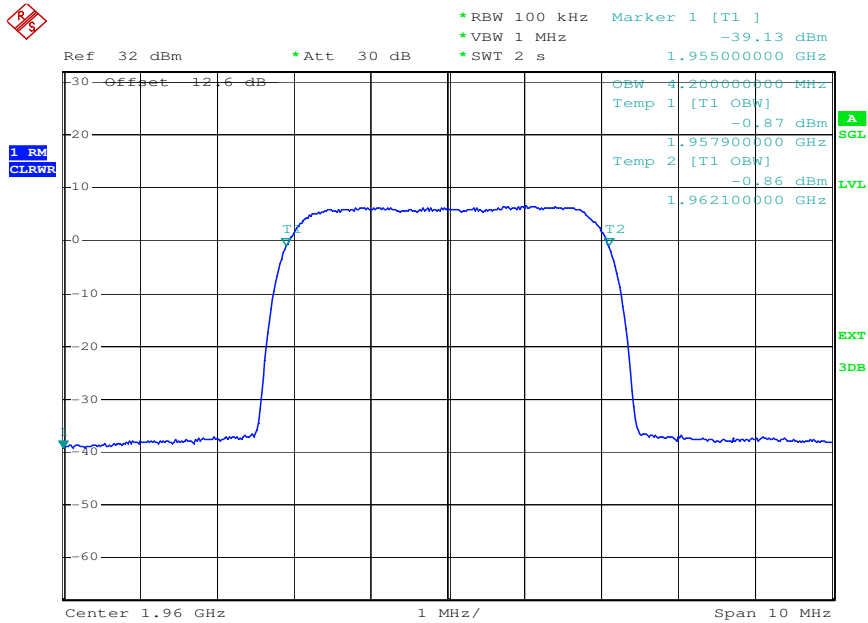

Date: 26.FEB.2010 09:53:23

plot 6.3.1.2-#1 Occupied Bandwidth: §2.1049; RSS-GEN; Test results; Downlink; W-CDMA Output

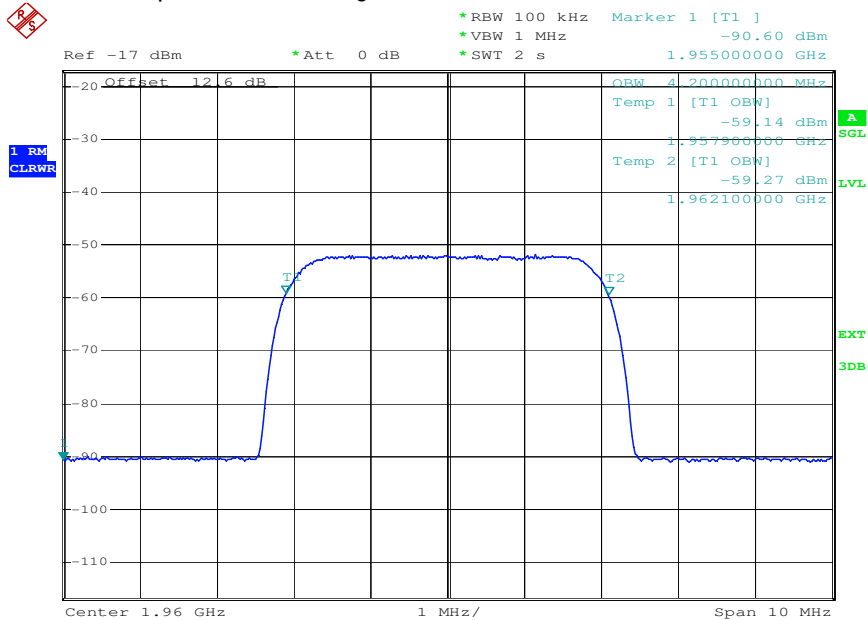

Date: 26.FEB.2010 09:48:21

plot 6.3.1.2-#2 Occupied Bandwidth: §2.1049; RSS-GEN; Test results; Downlink; W-CDMA Input



6.3.1.3 GSM

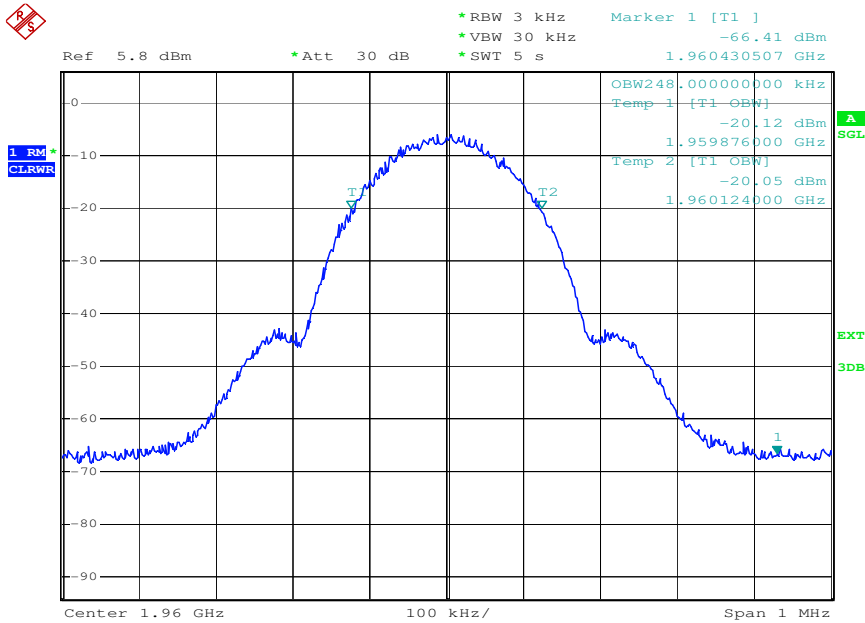

Date: 26.FEB.2010 10:03:56

plot 6.3.1.3-#1 Occupied Bandwidth: §2.1049; RSS-GEN; Test results; Downlink; GSM Output

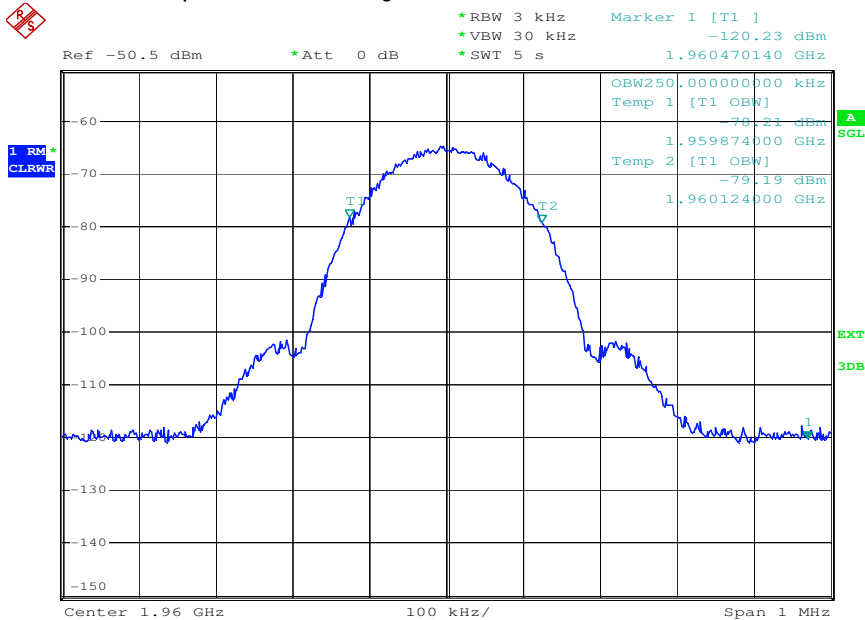

Date: 26.FEB.2010 10:06:14

plot 6.3.1.3-#2 Occupied Bandwidth: §2.1049; RSS-GEN; Test results; Downlink; GSM Input



6.3.2 Uplink

Detector: RMS.

Modulation	Measured at		RBW VBW Span	Occupied Bandwidth / MHz	Plot #
CDMA	Middle	1880,0 MHz	30kHz 300kHz 5MHz	1.27	6.3.2.1 #1, #2
WCDMA	Middle	1880,0 MHz	100kHz 1MHz 10MHz	4.20	6.3.2.2 #1, #2
GSM	Middle	1880,0 MHz	3kHz 30kHz 1MHz	0.248	6.3.2.3 #1, #2
GSM-EDGE	Middle	1880,0 MHz	3kHz 30kHz 1MHz	0.246	6.3.2.4 #1, #2

table 6.3-#2 Occupied Bandwidth: §2.1049; RSS-GEN Test results Uplink



6.3.2.1 CDMA

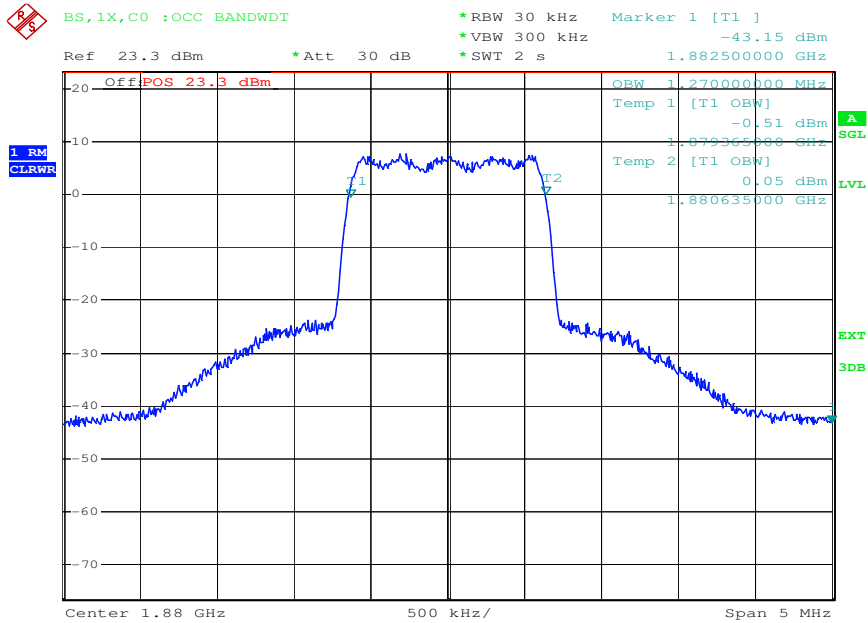

Date: 11.MAR.2010 14:05:39

plot 6.3.2.1-#1 Occupied Bandwidth: §2.1049; RSS-GEN; Test results; Uplink; CDMA Output

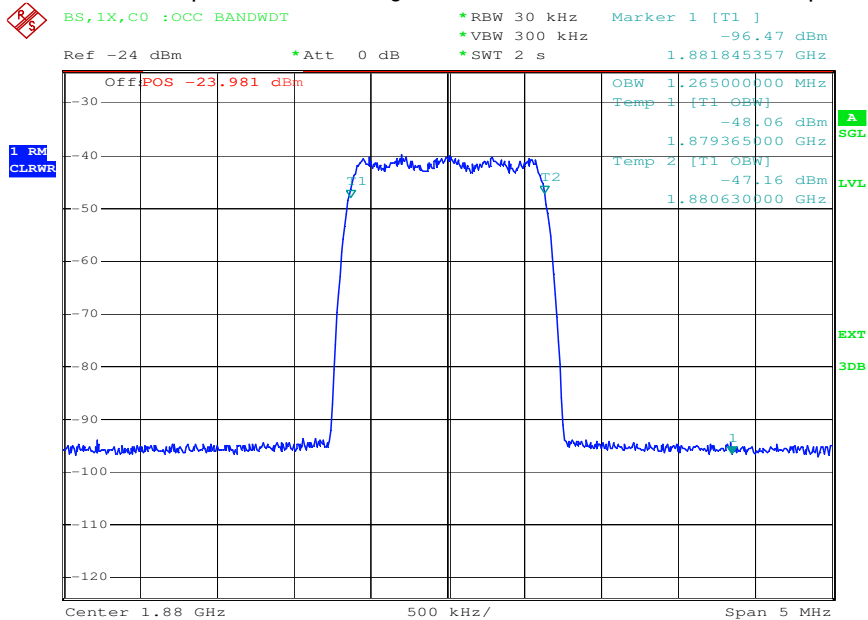

Date: 11.MAR.2010 14:08:11

plot 6.3.2.1-#2 Occupied Bandwidth: §2.1049; RSS-GEN; Test results; Uplink; CDMA Input



6.3.2.2 W-CDMA

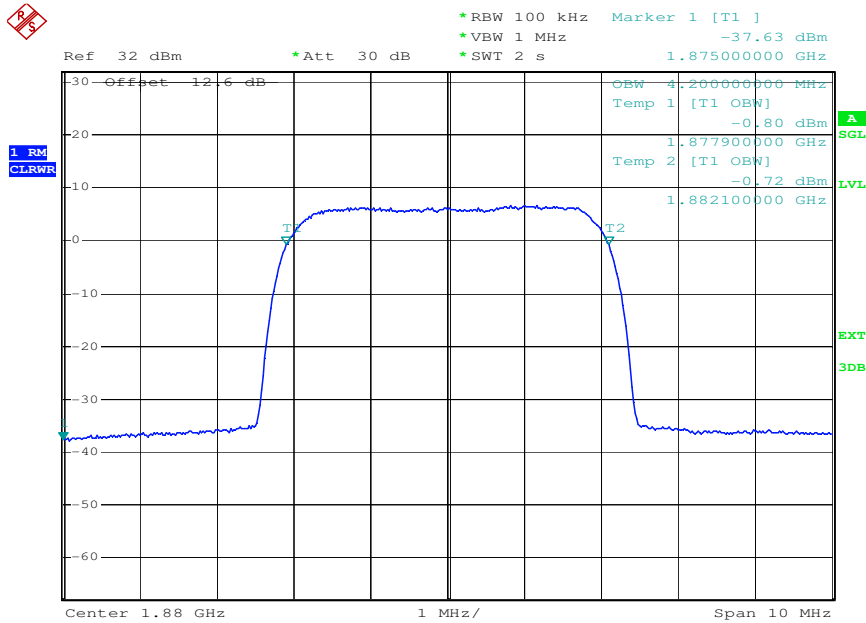

Date: 26.FEB.2010 09:44:11

plot 6.3.2.2-#1 Occupied Bandwidth: §2.1049; RSS-GEN; Test results; Uplink; W-CDMA Output

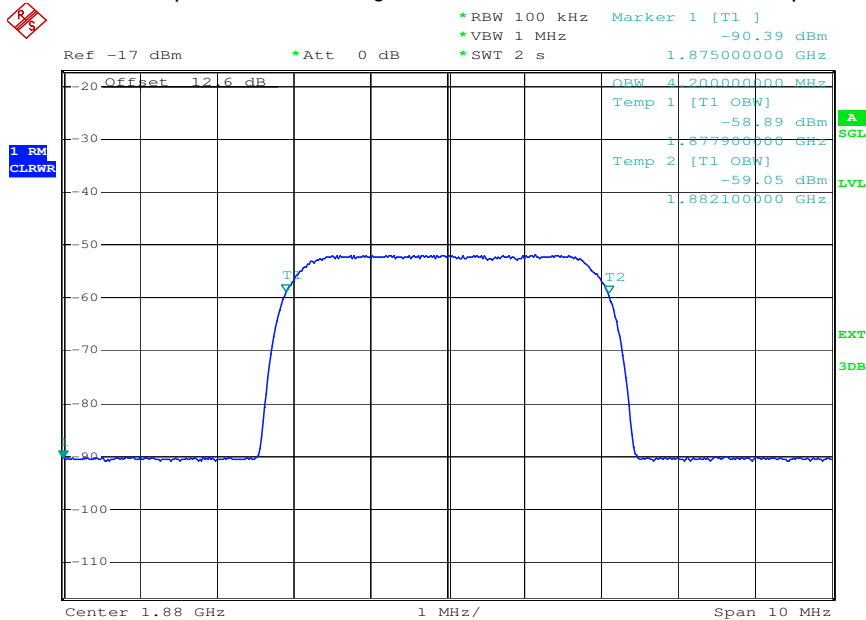

Date: 26.FEB.2010 09:46:46

plot 6.3.2.2-#2 Occupied Bandwidth: §2.1049; RSS-GEN; Test results; Uplink; W-CDMA Input



6.3.2.3 GSM

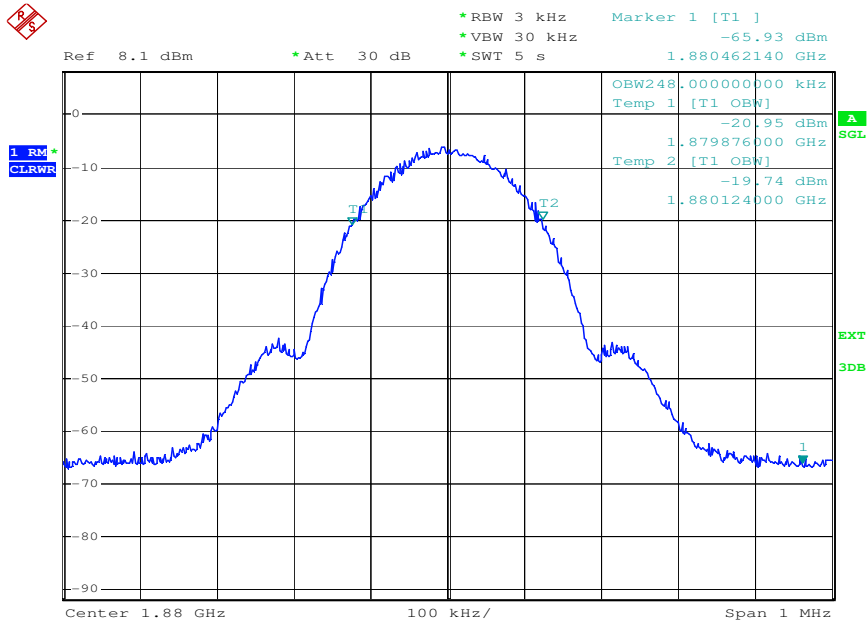

Date: 26.FEB.2010 10:10:03

plot 6.3.2.3-#1 Occupied Bandwidth: §2.1049; RSS-GEN; Test results; Uplink; GSM Output

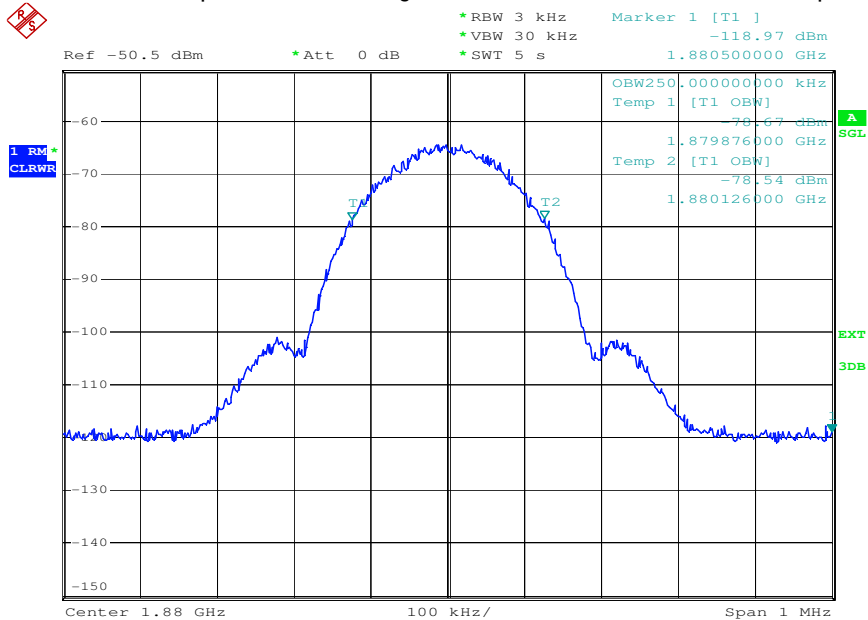

Date: 26.FEB.2010 10:07:23

plot 6.3.2.3-#2 Occupied Bandwidth: §2.1049; RSS-GEN; Test results; Uplink; GSM Input



6.3.2.4 GSM-EDGE

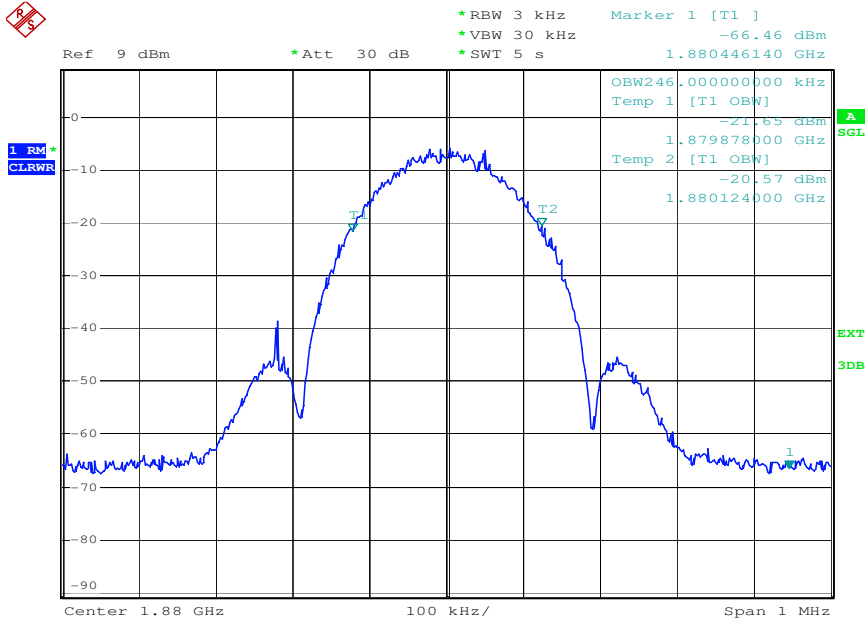

Date: 26.FEB.2010 10:17:19

plot 6.3.2.4-#1 Occupied Bandwidth: §2.1049; RSS-GEN; Test results; Uplink; GSM-EDGE Output

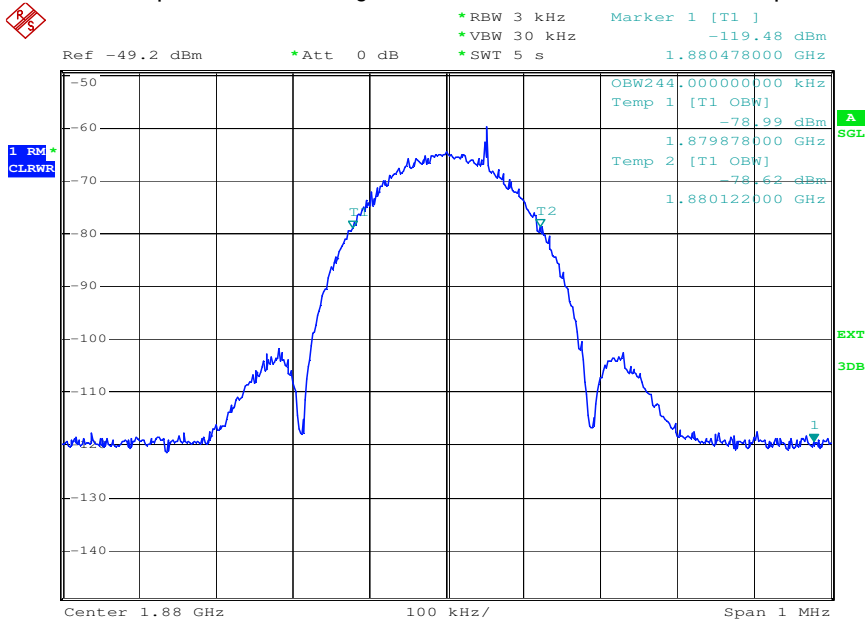

Date: 26.FEB.2010 10:14:30

plot 6.3.2.4-#2 Occupied Bandwidth: §2.1049; RSS-GEN; Test results; Uplink; GSM-EDGE Input

EMC Test Report No.: 10-035

FCC ID: XS5-MR191919

IC ID: 2237E-MR191919



6.4 Summary test result

Test result	complies, according the plots above
Tested by:	Roland Macho
Date:	26.02.2010

7 Spurious Emissions at Antenna Terminals: §24.238, §2.1051; RSS-132, RSS-GEN

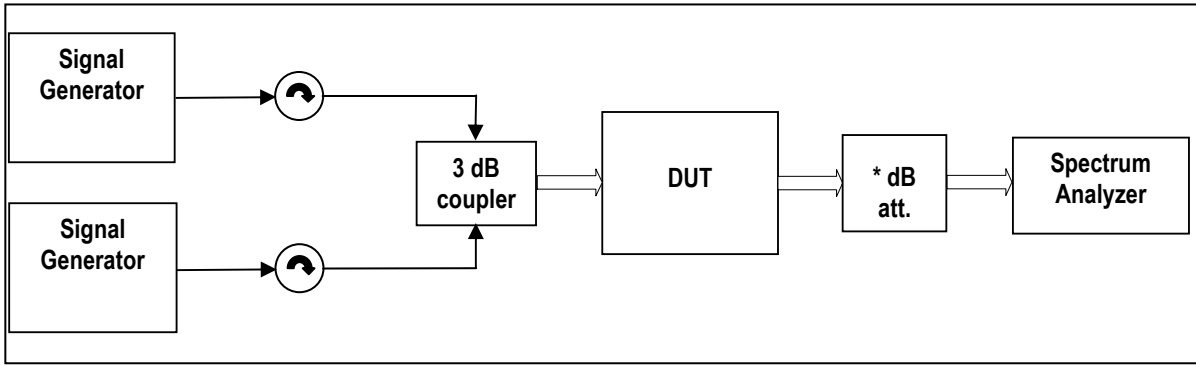

Multisignal-Generator used, External Attenuator DL x dB = 10 dB
 figure 7-#1 Test setup: Spurious Emissions at Antenna Terminals: §24.238, §2.1051; RSS-132, RSS-GEN

Measurement uncertainty	± 0,54 dB ± 1,2 dB ± 1,5 dB	9 kHz to 3 GHz 3 GHz to 7 GHz 7 GHz to 26 GHz
Test equipment used	8984,8686,8687,8961,7370	

7.1 Limit

7.1.1 FCC CFR47

Minimum standard:

Para. No.24.238(a)

The rules in this section govern the spectral characteristics of emissions in the Broadband Personal Communications Service.

(a) Out of band emissions. The power of any emission outside of the authorized operating frequency ranges must be attenuated below the transmitting power (P) by a factor of at least $43 + 10 \log(P)$ dB.

7.1.2 IC RSS-133

6.5 Transmitter Unwanted Emissions

6.5.1 Out-of-Block Emissions (Mobile and Base Stations)

(a) Mobile stations shall comply with subsection (i) below. Base stations shall comply with either subsection (i) or subsection (ii).

(i) In the first 1.0 MHz bands immediately outside and adjacent to the equipment's operating frequency block, the emission power per any 1% of the emission bandwidth shall be attenuated below the transmitter output power P (in watts) by at least $43 + 10 \log_{10}(P)$, dB.

(ii) In the first 1.5 MHz immediately outside and adjacent to the equipment's operating frequency block, the emission power at offset dF shall be less than the maximum level specified in Table 1.

Table 1: Spectrum Emission Mask of Base Station

Frequency Distance from the Edge of the Frequency Block, dF	Maximum Level (dBm)	Measurement Bandwidth (kHz)
0 - 0.2 MHz	-14	30
0.2 - 1.0 MHz	$-(14 + 15(dF - 0.2))$	30
1.0 - 1.5 MHz	-26	30

(b) After the first 1.0 MHz (for equipment that complies with (a)(i) of this subsection) or 1.5 MHz (for equipment that complies with (a)(ii) of this subsection), the emission power in any 1 MHz bandwidth shall be attenuated below the transmitter output power P (in watts) by at least $43 + 10 \log_{10}(P)$, dB. (Note: If the test result using 1% of the emission bandwidth is used, power integration over 1.0 MHz is required; alternatively, the spectrum analyzer resolution and video bandwidths can be increased to 1.0 MHz for this measurement).

7.2 Test method

7.2.1 FCC CFR47

Para. No 2.1051 Measurements required: Spurious emissions at antenna terminals.

The radio frequency voltage or powers generated within the equipment and appearing on a spurious frequency shall be checked at the equipment output terminals when properly loaded with a suitable artificial antenna. Curves or equivalent data shall show the magnitude of each harmonic and other spurious emission that can be detected when the equipment is operated under the conditions specified in § 2.1049 as appropriate. The magnitude of spurious emissions which are attenuated more than 20 dB below the permissible value need not be specified.

[39 FR 5919, Feb. 15, 1974. Redesignated and amended at 63 FR 36599, July 7, 1998]

7.2.2 IC RSS-GEN

4.9 Transmitter Unwanted Emissions

The measurement method shall be described in the test report. The same parameter, peak power or average power, used for the transmitter output power measurement shall be used for unwanted emission measurements.

The search for unwanted emissions shall be from the lowest frequency internally generated or used in the device (local oscillator, intermediate or carrier frequency), or from 30 MHz, whichever is the lower, to the 5th harmonic of the highest frequency generated without exceeding 40 GHz.

Unless otherwise specified, compliance with the emission limits shall be demonstrated using a CISPR quasi-peak detector and the related measurement bandwidth for emissions below 1000 MHz and, an average detector with a minimum resolution bandwidth of 1 MHz for emissions above 1 GHz.

7.3 Test results

7.3.1 Downlink

<1MHz from Band Edge

Detector: RMS.

Modulation	Measured at Band Edge	Carriers	RBW VBW Span	Max. level (dBm)	Plot -
CDMA	Lower Edge Upper Edge	1930,70 MHz	30kHz	-21,8	7.3.1.1 #1
		1931,95 MHz 1988,05 MHz 1989,30 MHz	300kHz 6MHz	-23,1	#2
WCDMA	Lower Edge Upper Edge	1932,4 MHz	100kHz	-29,8	7.3.1.2 #1
		1937,4 MHz 1982,6 MHz 1987,6 MHz	300kHz 15MHz	-27,5	#2
GSM	Lower Edge Upper Edge	1930,2 MHz	3kHz	-36,4	7.3.1.3 #1
		1930,4 MHz 1989,6 MHz 1989,8 MHz	30kHz 2MHz	-36,9	#2
GSM-EDGE	Lower Edge Upper Edge	1930,2 MHz	3kHz	-33,0	7.3.1.4 #1
		1930,4 MHz 1989,6 MHz 1989,8 MHz	30kHz 2MHz	-35,9	#2

table 7.3-#1 Spurious Emissions at Antenna Terminals: §24.238, §2.1051; RSS-132, RSS-GEN Test results Downlink <1MHz from Band Edge

>1MHz from Band Edge

Detector: RMS.

Modulation	Carrier at	Carrier	Max. level (dBm)	RBW VBW Frequency range	Plot -
CDMA	Middle	1960 MHz	-38,0	1MHz 3MHz 30MHz – 20GHz	7.3.1.5 #1
WCDMA	Middle	1960 MHz	-42,0	1MHz 3MHz 30MHz – 20GHz	7.3.1.6 #1
GSM	Middle	1960 MHz	-42,0	1MHz 3MHz 30MHz – 20GHz	7.3.1.7 #1
GSM-EDGE	Middle	1960 MHz	-41,0	1MHz 3MHz 30MHz – 20GHz	7.3.1.8 #1

table 7.3-#2 Spurious Emissions at Antenna Terminals: §24.238, §2.1051; RSS-132, RSS-GEN Test results Downlink >1MHz from Band Edge



7.3.1.1 CDMA < 1MHz to band edge

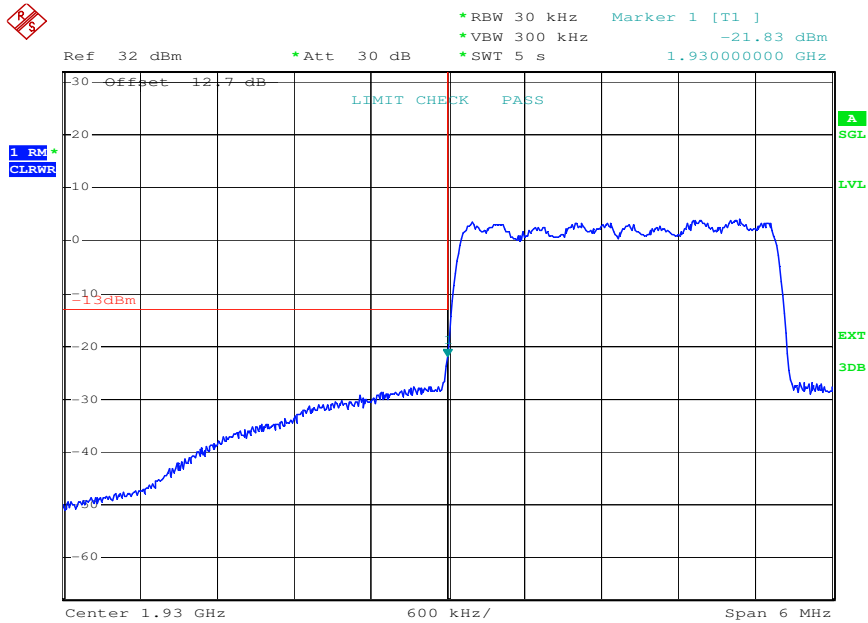

Date: 11.MAR.2010 15:50:00

plot 7.3.1.1-#1 Spurious Emissions at Antenna Terminals: §24.238, §2.1051; RSS-132, RSS-GEN; Test results; Downlink; CDMA < 1MHz to band edge Lower Band Edge

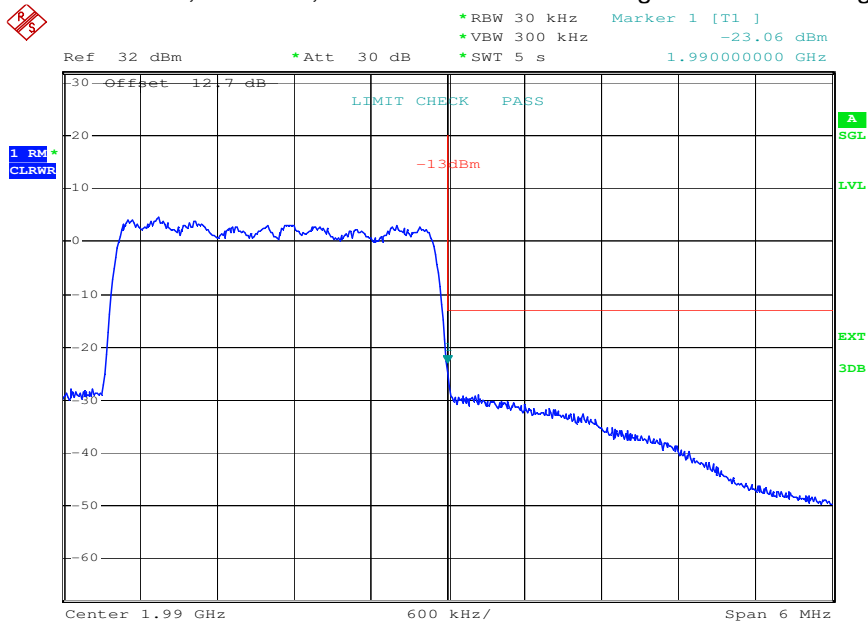

Date: 11.MAR.2010 15:50:28

plot 7.3.1.1-#2 Spurious Emissions at Antenna Terminals: §24.238, §2.1051; RSS-132, RSS-GEN; Test results; Downlink; CDMA < 1MHz to band edge Upper Band Edge



7.3.1.2 W-CDMA < 1MHz to band edge

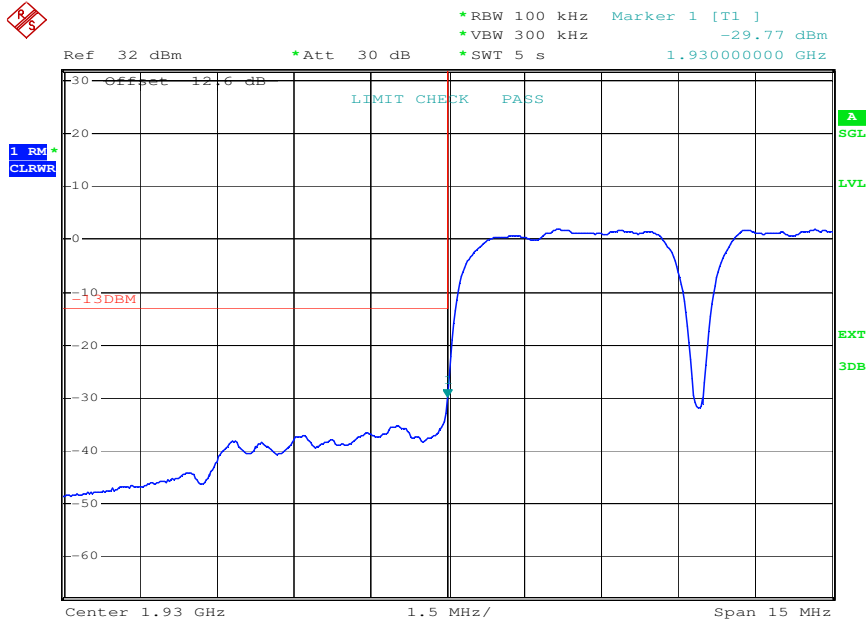

Date: 25.FEB.2010 18:30:25

plot 7.3.1.2-#1 Spurious Emissions at Antenna Terminals: §24.238, §2.1051; RSS-132, RSS-GEN; Test results; Downlink; W-CDMA < 1MHz to band edge Lower Band Edge

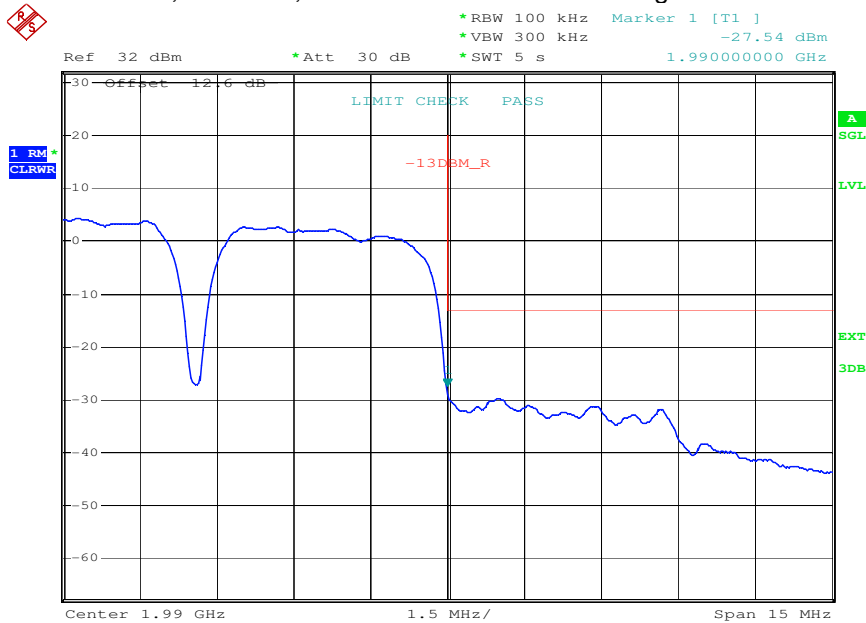

Date: 25.FEB.2010 18:39:29

plot 7.3.1.2-#2 Spurious Emissions at Antenna Terminals: §24.238, §2.1051; RSS-132, RSS-GEN; Test results; Downlink; W-CDMA < 1MHz to band edge Upper Band Edge



7.3.1.3 GSM < 1MHz to band edge

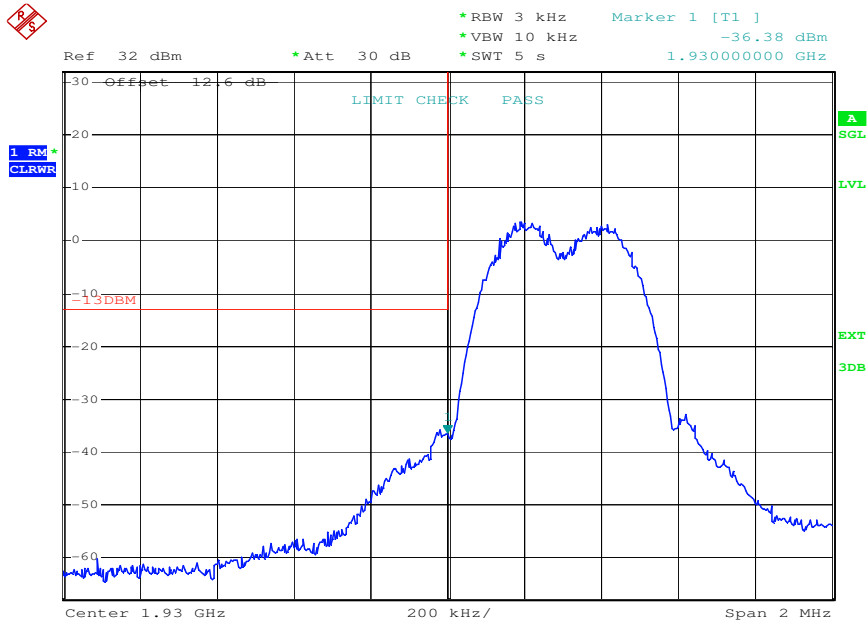

Date: 25.FEB.2010 19:43:25

plot 7.3.1.3-#1 Spurious Emissions at Antenna Terminals: §24.238, §2.1051; RSS-132, RSS-GEN; Test results; Downlink; GSM < 1MHz to band edge Lower Band Edge

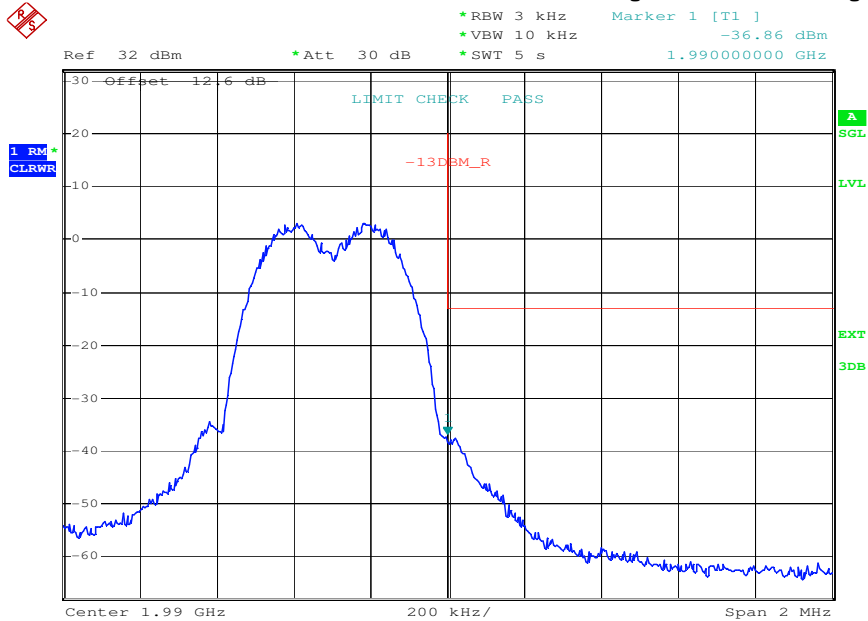

Date: 25.FEB.2010 19:37:56

plot 7.3.1.3-#2 Spurious Emissions at Antenna Terminals: §24.238, §2.1051; RSS-132, RSS-GEN; Test results; Downlink; GSM < 1MHz to band edge Upper Band Edge



7.3.1.4 GSM-EDGE < 1MHz to band edge

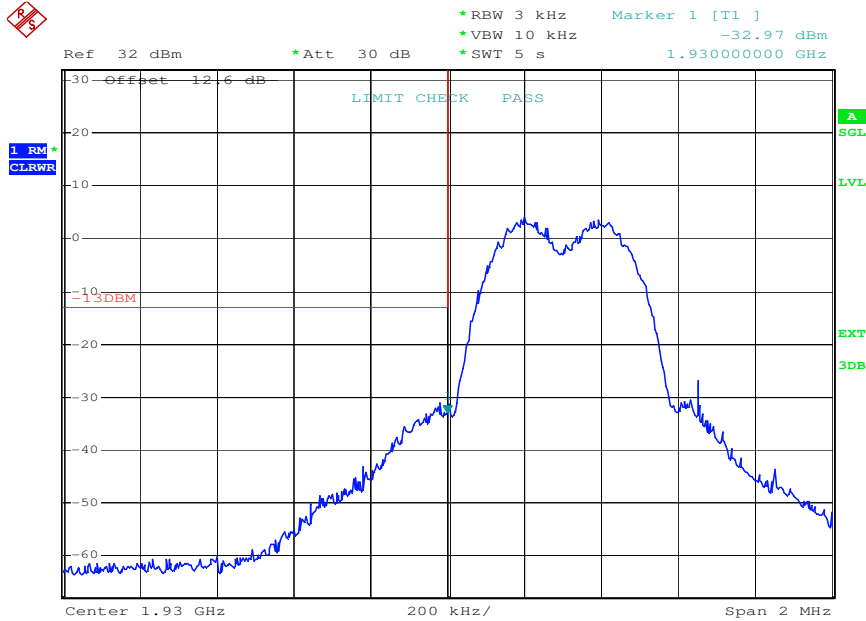

Date: 25.FEB.2010 20:11:16

plot 7.3.1.4-#1 Spurious Emissions at Antenna Terminals: §24.238, §2.1051; RSS-132, RSS-GEN; Test results; Downlink; GSM-EDGE < 1MHz to band edge Lower Band Edge

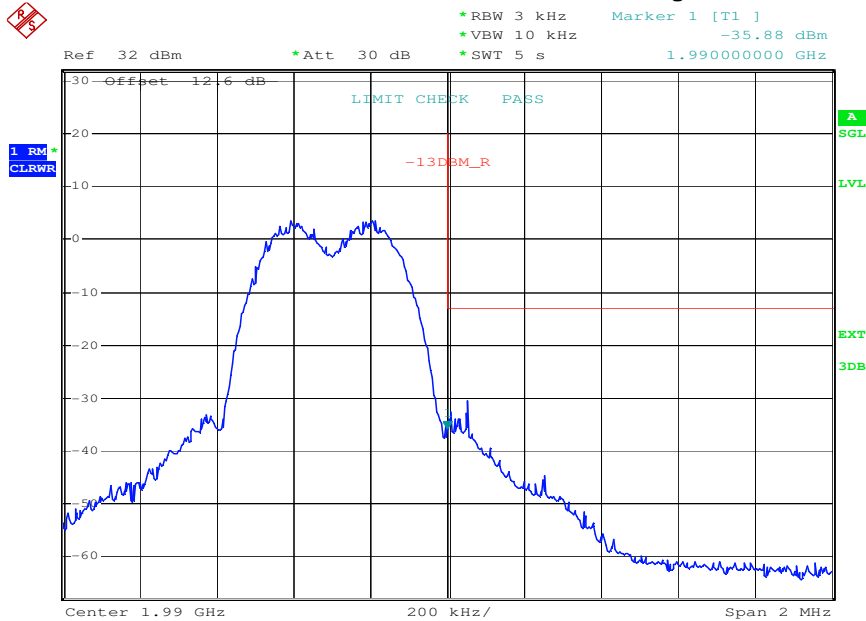

Date: 25.FEB.2010 20:15:47

plot 7.3.1.4-#2 Spurious Emissions at Antenna Terminals: §24.238, §2.1051; RSS-132, RSS-GEN; Test results; Downlink; GSM-EDGE < 1MHz to band edge Upper Band Edge



7.3.1.5 CDMA > 1MHz to band edge

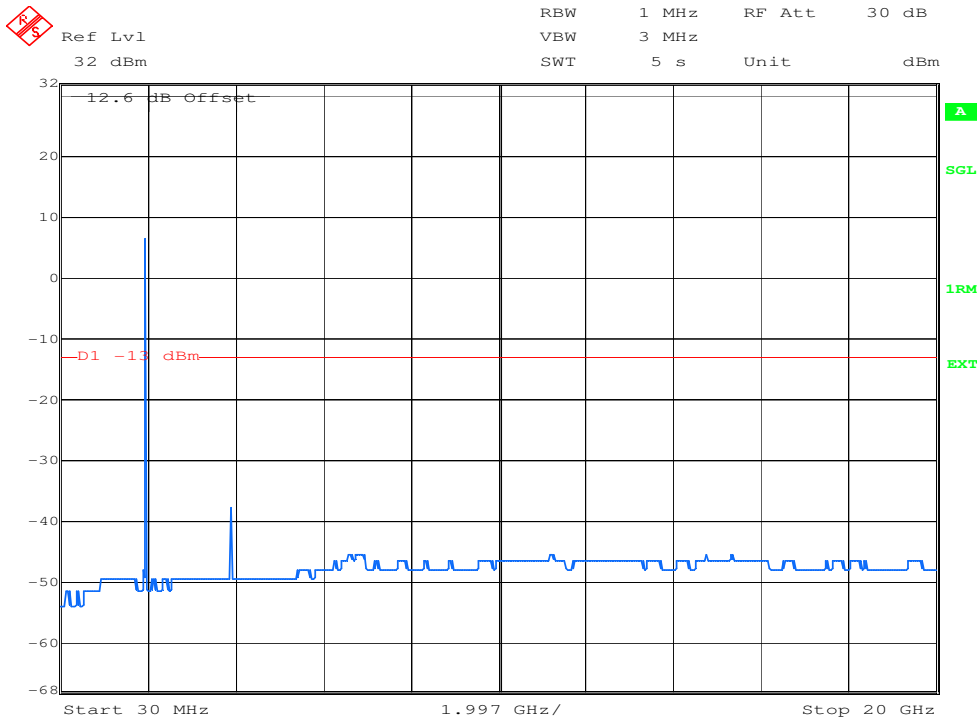

Date: 25.FEB.2010 16:39:48
plot 7.3.1.5-#1 Spurious Emissions at Antenna Terminals: §24.238, §2.1051; RSS-132, RSS-GEN; Test results; Downlink; CDMA > 1MHz to band edge;

7.3.1.6 W-CDMA > 1MHz to band edge

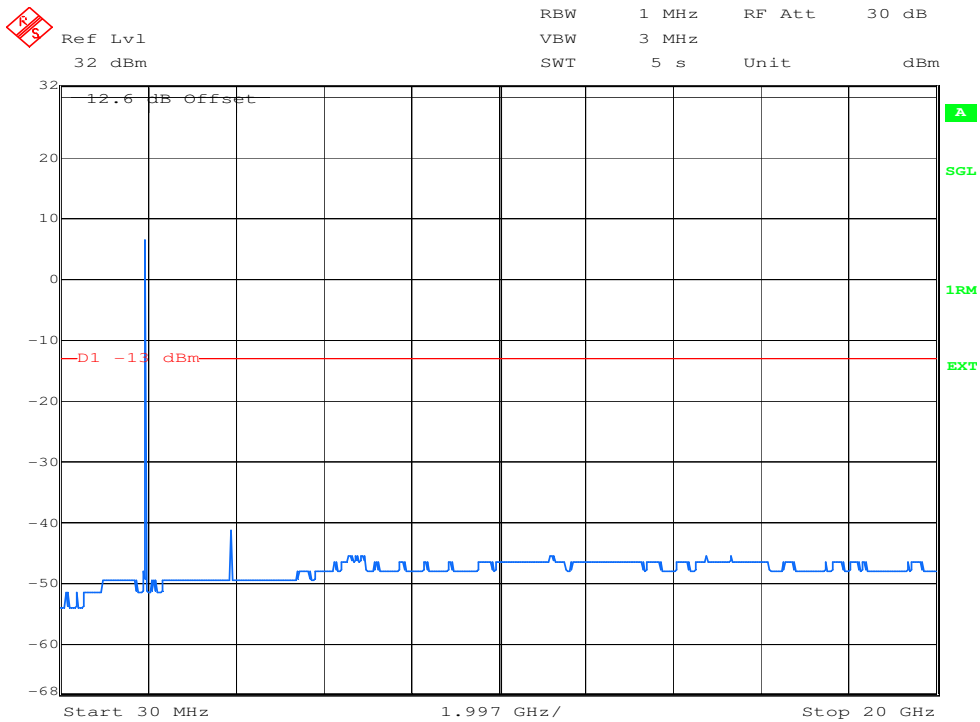

Date: 25.FEB.2010 16:02:28
plot 7.3.1.6-#1 Spurious Emissions at Antenna Terminals: §24.238, §2.1051; RSS-132, RSS-GEN; Test results; Downlink; W-CDMA > 1MHz to band edge;



7.3.1.7 GSM > 1MHz to band edge

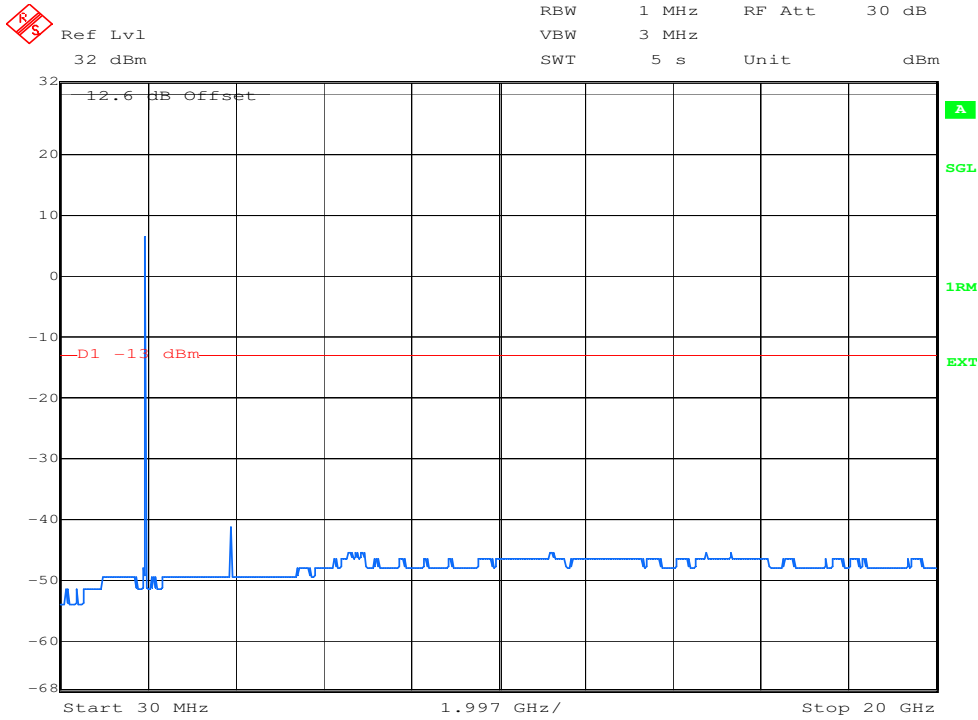

plot 7.3.1.7-#1 Spurious Emissions at Antenna Terminals: §24.238, §2.1051; RSS-132, RSS-GEN; Test results; Downlink; GSM > 1MHz to band edge;

7.3.1.8 GSM-EDGE > 1MHz to band edge

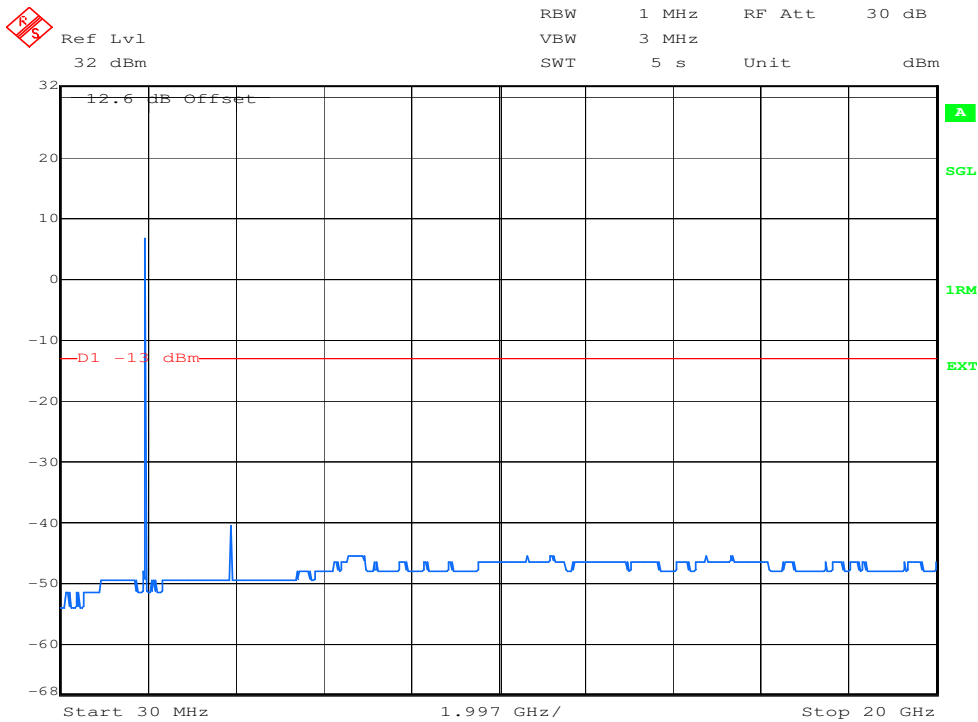

plot 7.3.1.8-#1 Spurious Emissions at Antenna Terminals: §24.238, §2.1051; RSS-132, RSS-GEN; Test results; Downlink; GSM-EDGE > 1MHz to band edge;

7.3.2 Uplink

<1MHz from Band Edge

Detector: RMS.

Modulation	Measured at Band Edge	Carriers	RBW VBW Span	Max. level (dBm)	Plot -
CDMA	Lower Edge	1850,70 MHz	30kHz 300kHz 6MHz	-22,1	7.3.2.1 #1
	Upper Edge	1851,95 MHz 1908,05 MHz 1909,30 MHz		-21,4	#2
WCDMA	Lower Edge	1852,4 MHz	100kHz 300kHz 15MHz	-25,3	7.3.2.2 #1
	Upper Edge	1857,4 MHz 1902,6 MHz 1907,6 MHz		-25,1	#2
GSM	Lower Edge	1850,2 MHz	3kHz 30kHz 2MHz	-36,6	7.3.2.3 #1
	Upper Edge	1850,4 MHz 1909,6 MHz 1909,8 MHz		-37,7	#2
GSM-EDGE	Lower Edge	1850,2 MHz	3kHz 30kHz 2MHz	-38,0	7.3.2.4 #1
	Upper Edge	1850,4 MHz 1909,6 MHz 1909,8 MHz		-27,7	#2

table 7.3-#3 Spurious Emissions at Antenna Terminals: §24.238, §2.1051; RSS-132, RSS-GEN Test results Uplink <1MHz from Band Edge

>1MHz from Band Edge

Detector: RMS.

Modulation	Carrier at	Carrier	Max. level (dBm)	RBW VBW Frequency range	Plot -
CDMA	Middle	1880 MHz	-46,0	1MHz 3MHz 30MHz – 20GHz	7.3.2.5 #1
WCDMA	Middle	1880 MHz	-46,5	1MHz 3MHz 30MHz – 20GHz	7.3.2.6 #1
GSM	Middle	1880 MHz	-47,0	1MHz 3MHz 30MHz – 20GHz	7.3.2.7 #1
GSM-EDGE	Middle	1880 MHz	-47,5	1MHz 3MHz 30MHz – 20GHz	7.3.2.8 #1

table 7.3-#4 Spurious Emissions at Antenna Terminals: §24.238, §2.1051; RSS-132, RSS-GEN Test results Uplink >1MHz from Band Edge



7.3.2.1 CDMA < 1MHz to band edge

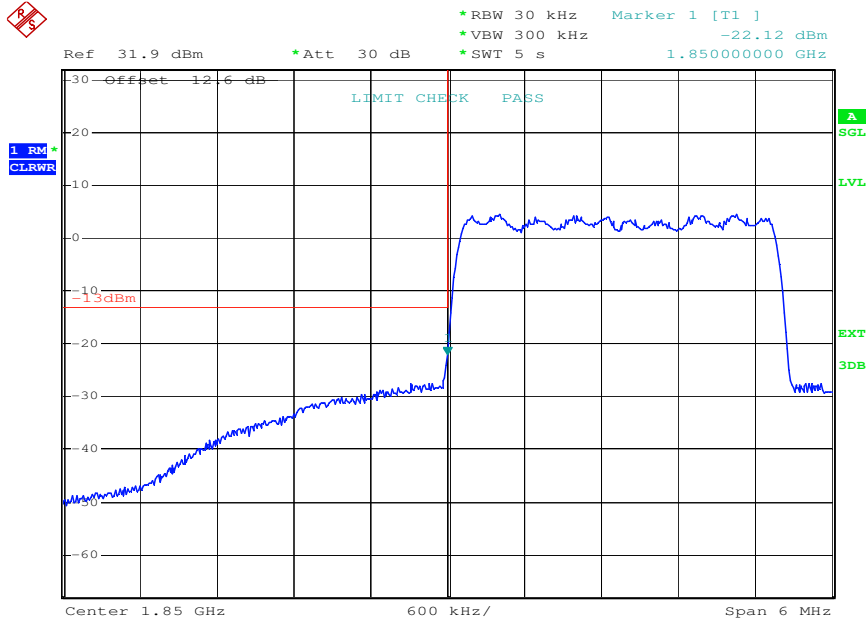

Date: 11.MAR.2010 15:50:56

plot 7.3.2.1-#1 Spurious Emissions at Antenna Terminals: §24.238, §2.1051; RSS-132, RSS-GEN; Test results; Uplink; CDMA < 1MHz to band edge Lower Band Edge

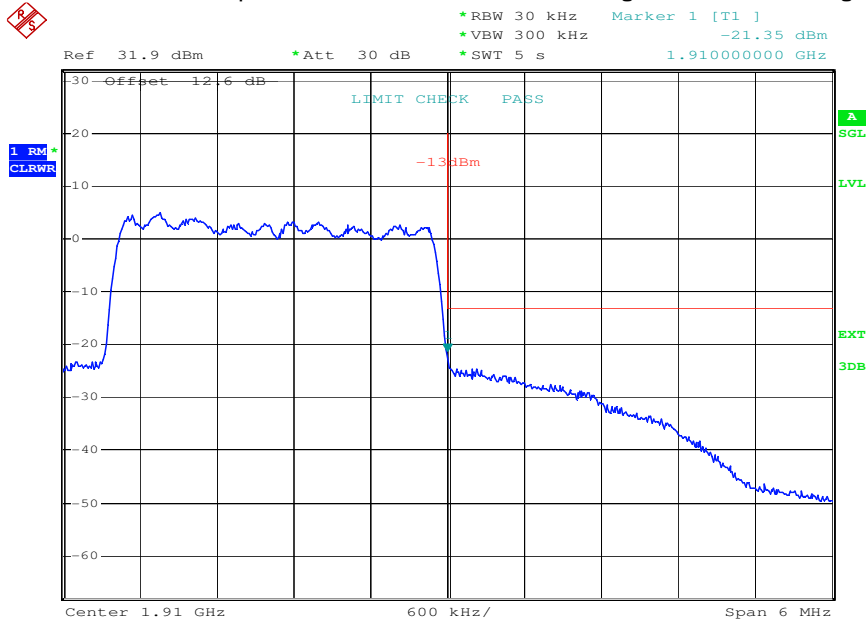

Date: 11.MAR.2010 15:51:24

plot 7.3.2.1-#2 Spurious Emissions at Antenna Terminals: §24.238, §2.1051; RSS-132, RSS-GEN; Test results; Uplink; CDMA < 1MHz to band edge Upper Band Edge



7.3.2.2 W-CDMA < 1MHz to band edge

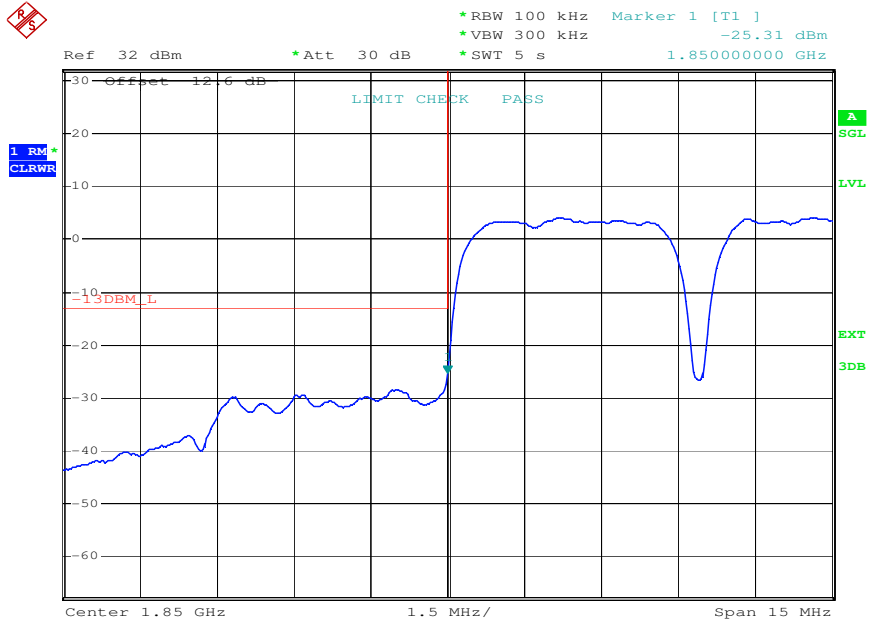

Date: 25.FEB.2010 18:50:55

plot 7.3.2.2-#1 Spurious Emissions at Antenna Terminals: §24.238, §2.1051; RSS-132, RSS-GEN; Test results; Uplink; W-CDMA < 1MHz to band edge Lower Band Edge

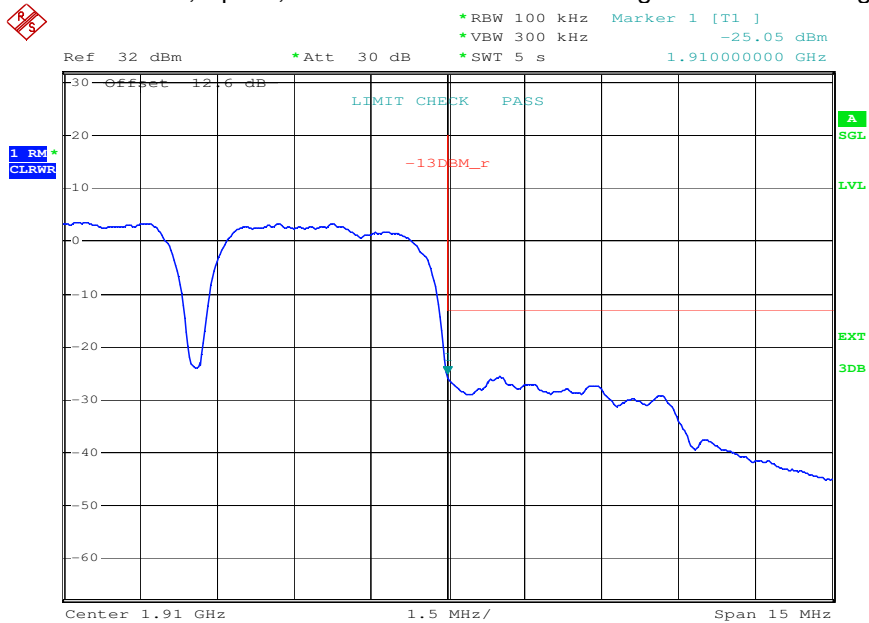

Date: 25.FEB.2010 19:01:29

plot 7.3.2.2-#2 Spurious Emissions at Antenna Terminals: §24.238, §2.1051; RSS-132, RSS-GEN; Test results; Uplink; W-CDMA < 1MHz to band edge Upper Band Edge



7.3.2.3 GSM < 1MHz to band edge

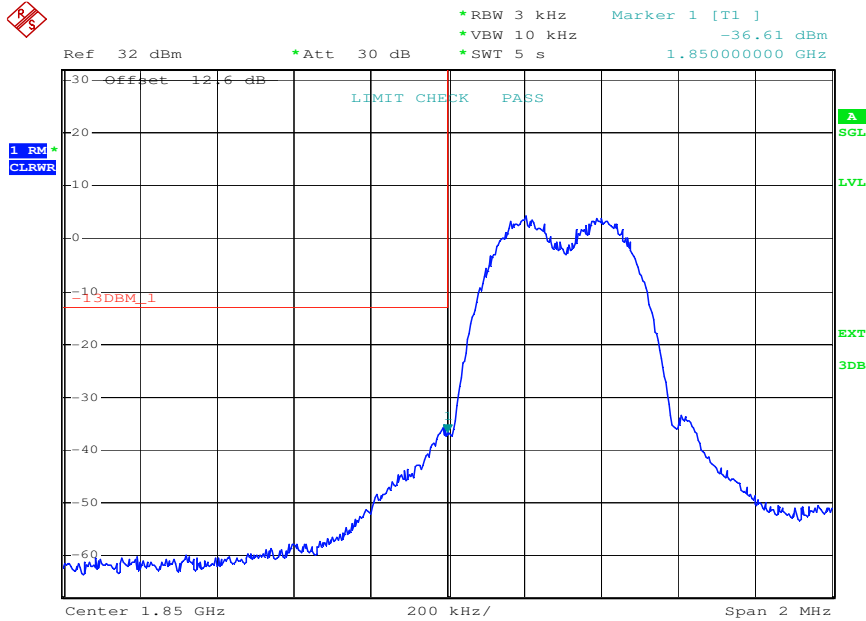

Date: 25.FEB.2010 19:50:16

plot 7.3.2.3-#1 Spurious Emissions at Antenna Terminals: §24.238, §2.1051; RSS-132, RSS-GEN; Test results; Uplink; GSM < 1MHz to band edge Lower Band Edge

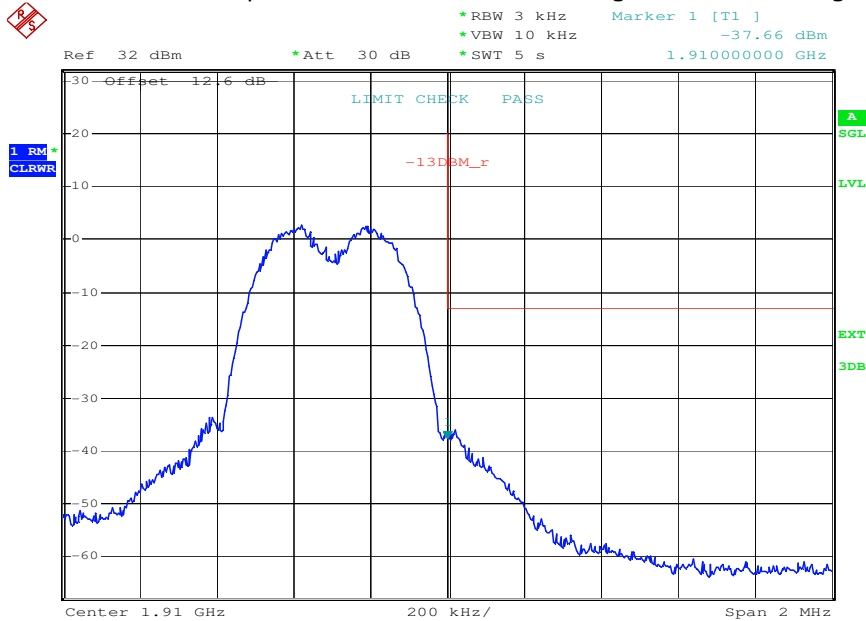

Date: 25.FEB.2010 19:25:24

plot 7.3.2.3-#2 Spurious Emissions at Antenna Terminals: §24.238, §2.1051; RSS-132, RSS-GEN; Test results; Uplink; GSM < 1MHz to band edge Upper Band Edge



7.3.2.4 GSM-EDGE < 1MHz to band edge

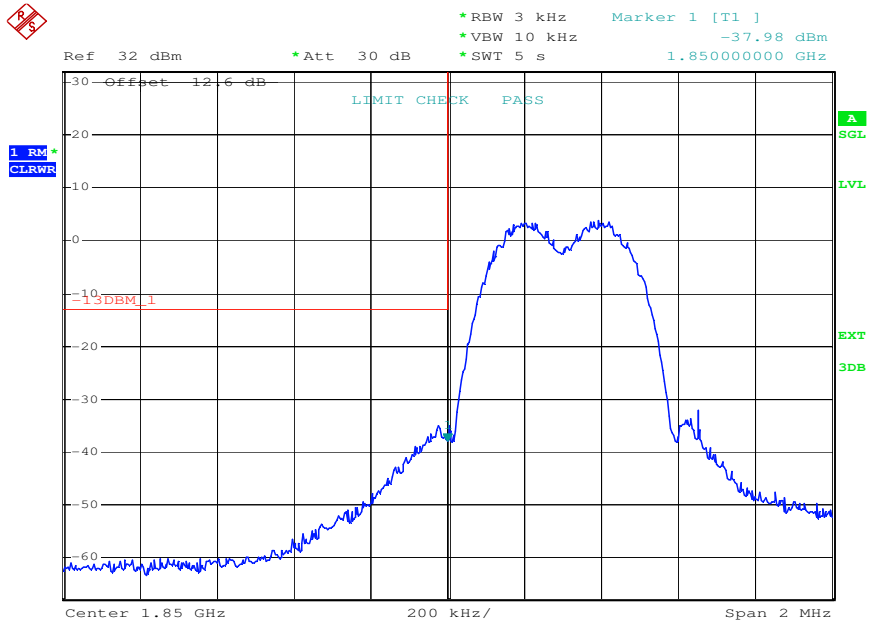

Date: 25.FEB.2010 19:57:01

plot 7.3.2.4-#1 Spurious Emissions at Antenna Terminals: §24.238, §2.1051; RSS-132, RSS-GEN; Test results; Uplink; GSM-EDGE < 1MHz to band edge Lower Band Edge

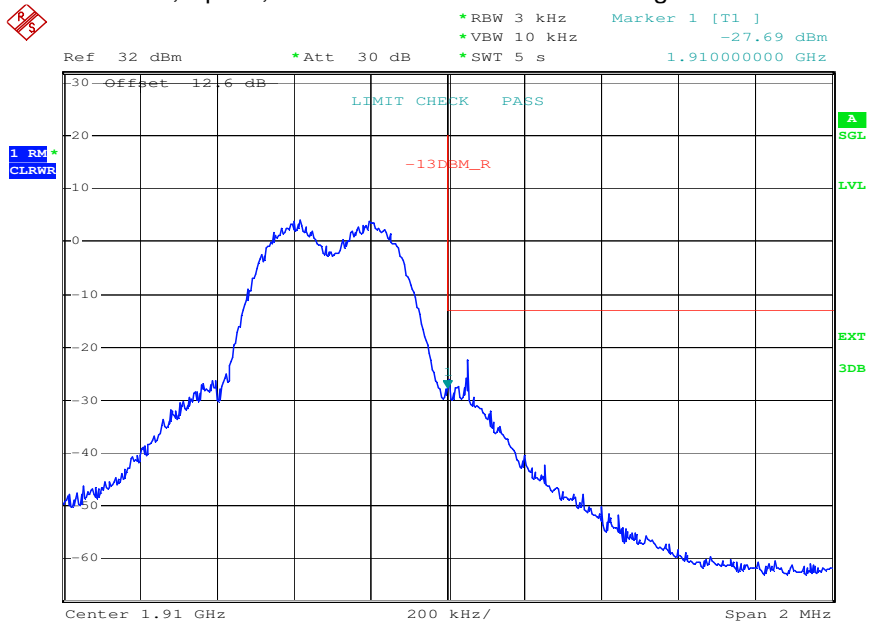

Date: 25.FEB.2010 20:19:28

plot 7.3.2.4-#2 Spurious Emissions at Antenna Terminals: §24.238, §2.1051; RSS-132, RSS-GEN; Test results; Uplink; GSM-EDGE < 1MHz to band edge Upper Band Edge



7.3.2.5 CDMA > 1MHz to band edge

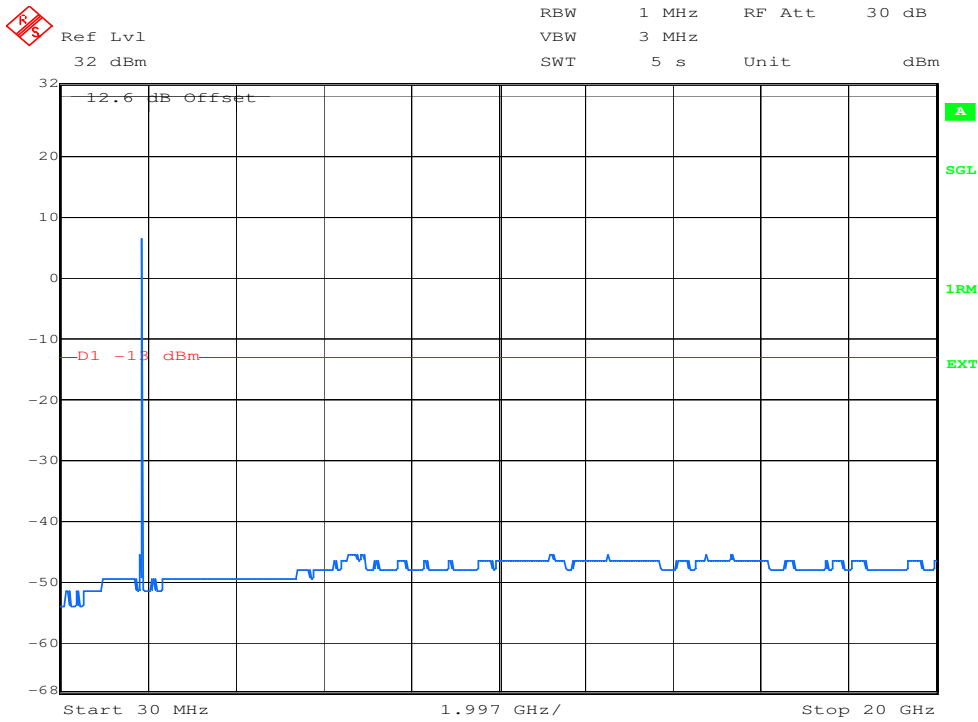

Date: 25.FEB.2010 16:26:47

plot 7.3.2.5-#1 Spurious Emissions at Antenna Terminals: §24.238, §2.1051; RSS-132, RSS-GEN; Test results; Uplink; CDMA > 1MHz to band edge;

7.3.2.6 W-CDMA > 1MHz to band edge

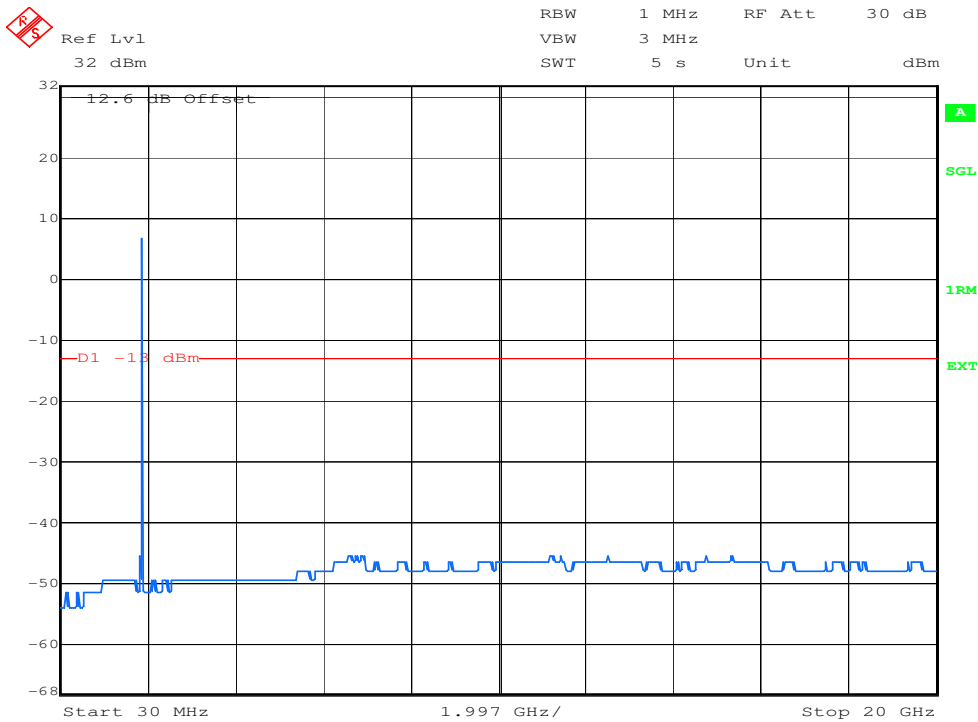

Date: 25.FEB.2010 16:22:06

plot 7.3.2.6-#1 Spurious Emissions at Antenna Terminals: §24.238, §2.1051; RSS-132, RSS-GEN; Test results; Uplink; W-CDMA > 1MHz to band edge;



7.3.2.7 GSM > 1MHz to band edge

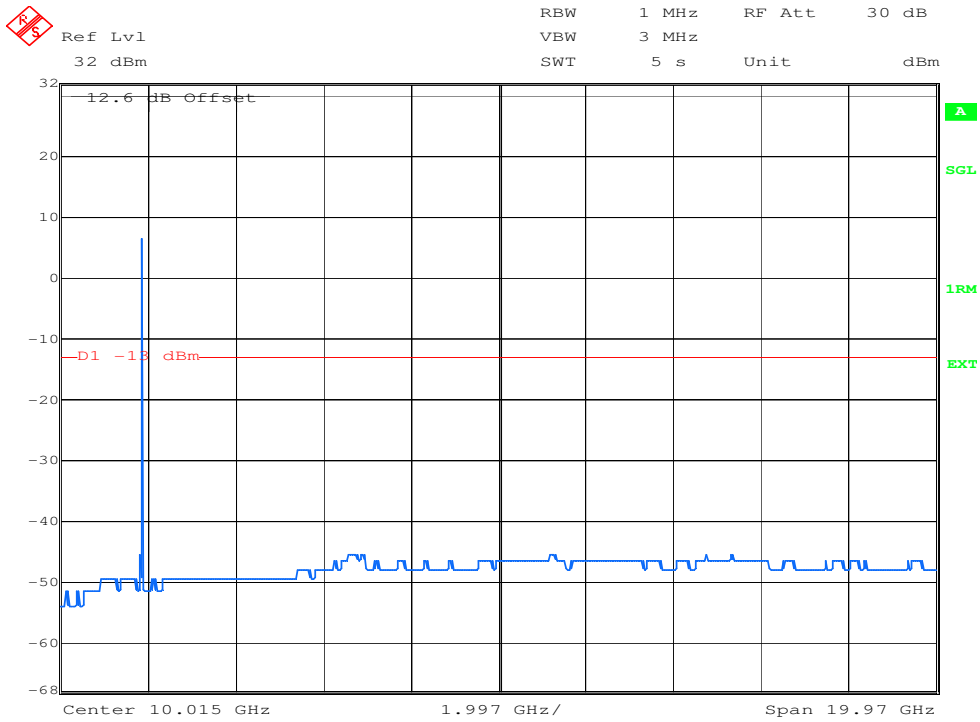

Date: 25.FEB.2010 16:10:51
plot 7.3.2.7-#1 Spurious Emissions at Antenna Terminals: §24.238, §2.1051; RSS-132, RSS-GEN; Test results; Uplink; GSM > 1MHz to band edge;

7.3.2.8 GSM-EDGE > 1MHz to band edge

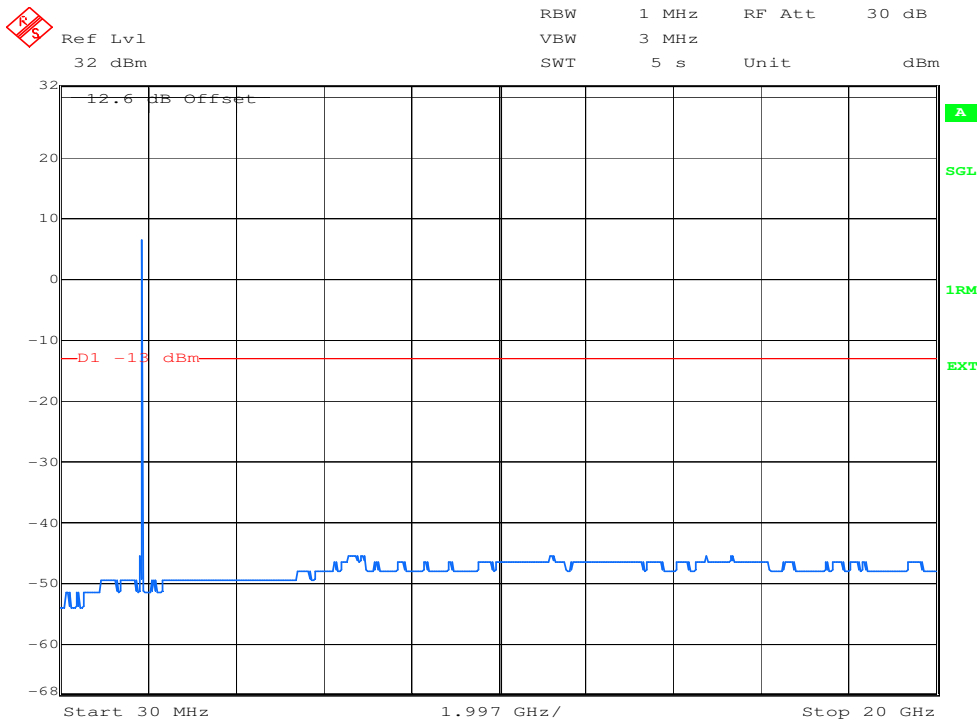

Date: 25.FEB.2010 15:43:57
plot 7.3.2.8-#1 Spurious Emissions at Antenna Terminals: §24.238, §2.1051; RSS-132, RSS-GEN; Test results; Uplink; GSM-EDGE > 1MHz to band edge;

EMC Test Report No.: 10-035

FCC ID: XS5-MR191919

IC ID: 2237E-MR191919



7.4 Summary test result

Test result	complies, according the plots above
Tested by:	Roland Macho
Date:	25.02.2010

8 Field Strength of Spurious Emissions: §24.53, §2.1053



picture 8.1: Test setup: Field Strength Emission >1 GHz @3m in the FAC

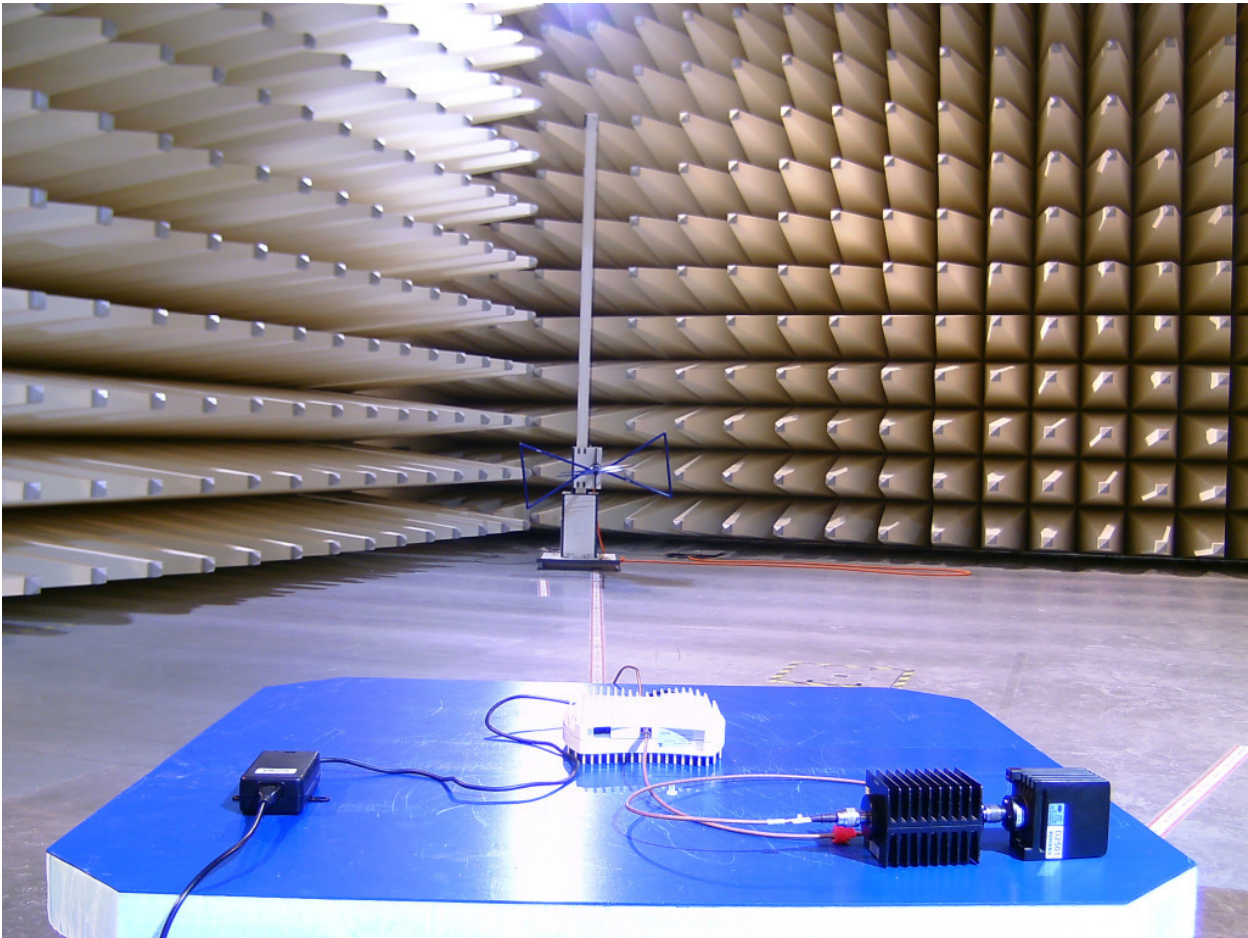

picture 8.2: Test setup: Field Strength Emission <1 GHz @10m in the SAC

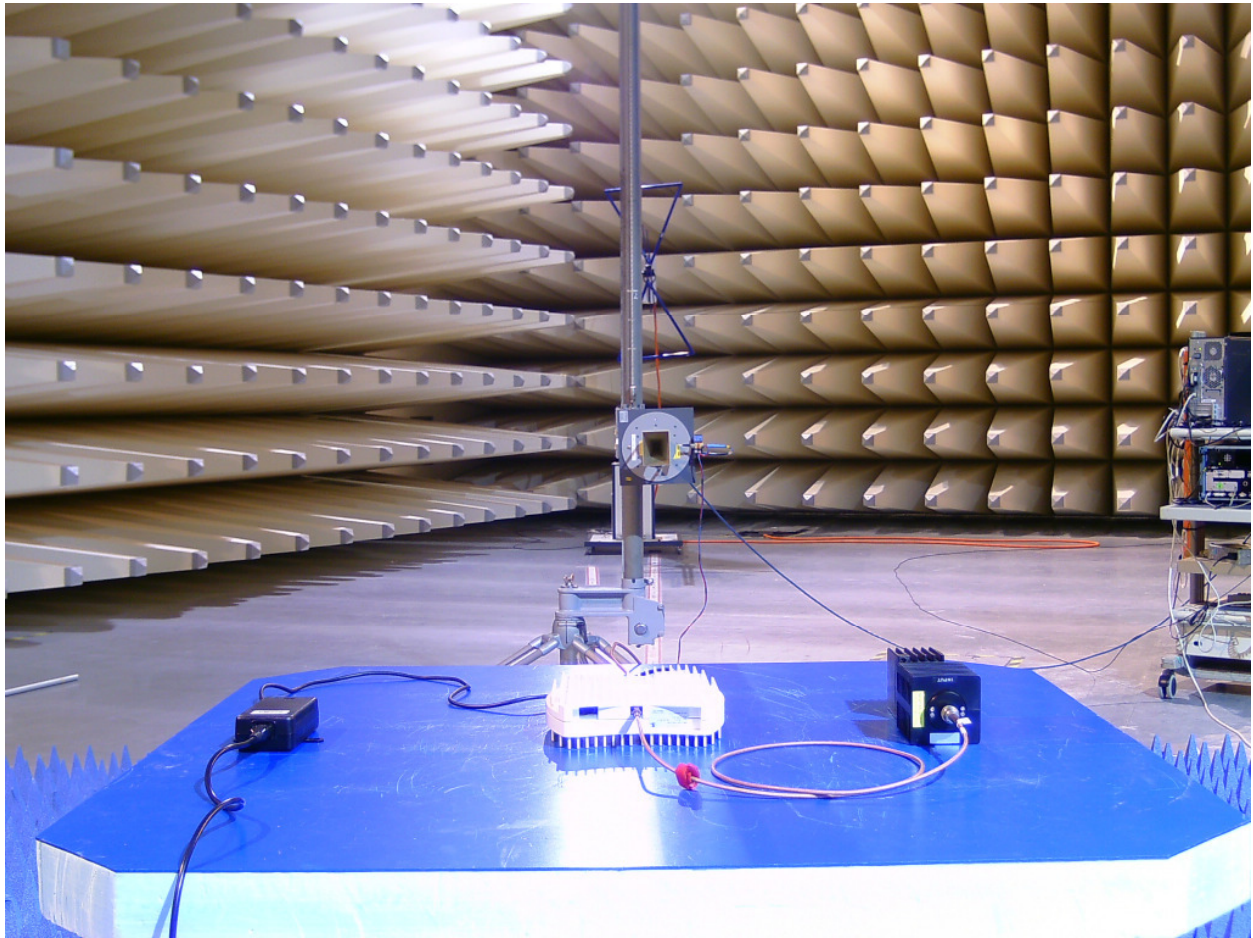

picture 8.3: Test setup: Field Strength Emission >20 GHz @3m in the SAC with Absorber material

This clause specifies requirements for the measurement of radiated emission.

Frequency range	Distance: EUT <-> antenna / location	Limit	Test method
30 MHz - 1 GHz	10 metres / SAC	FCC 47 CFR Part 24.238 IC RSS-133 sec. 6.5	TIA/EIA-603-C:2004
1 GHz – 22 GHz	3 metres / FAC	FCC 47 CFR Part 24.238 IC RSS-133 sec. 6.5	

Test equipment used:

Designation	Type	Manufacturer	Invent.-no.	Cal.-date	due Cal- date	used
EMI test receiver	ESI40	Rohde & Schwarz	E1687	20.10.2009	20.10.2010	X
EMI test receiver	ESI40	Rohde & Schwarz	E1607	04.03.2009	04.03.2010	
Antenna	CBL 6111	Chase	K1149	14.09.2009	14.09.2010	X
Antenna	CBL 6111	Chase	K1026	14.09.2009	14.09.2010	
RF Cable		Frankonia	K1121 SET	28.12.2009	28.12.2010	X
Pre amplifier	AM1431	Miteq	K1721	27.04.2009	27.04.2010	X
Antenna	HL 025	R&S	K809	06.05.2009	06.05.2010	X
Antenna	MWH-1826 / B	ARA Inc.	K1042	06.04.2009	06.04.2010	
Antenna	MWH-2640 / B	ARA Inc.	K1043	06.04.2009	06.04.2010	
Preamplifier	AFS4-00102000	Miteq	K817	11.11.2009	11.11.2010	X
Preamplifier	AFS4-00102000	Miteq	K838	06.10.2009	06.10.2010	
Preamplifier	JS43-1800-4000	Miteq	K1104	26.08.2009	26.08.2010	
RF Cable	Sucoflex 100	Suhner	K1742	09.04.2009	09.04.2010	X

The Tile-Software Version 4 has been used to maximize radiated emission from the EUT in the frequency area up to 1 GHz. Above 1 GHz the REMI version 2.135 has been used for max search.

Test set-up:

Test location: SAC/FAC
 Both, the Fully Anechoic Chamber (FAC) and the Semi Anechoic Chamber (SAC) fulfil the requirements of ANSI C63.4 and CISPR 16-1-4 with regards to NSA and SVSWR.

Test Voltage: 115V / 60 Hz
 Type of EUT: Wall mounted

Measurement uncertainty:

Measurement uncertainty expanded (95% or K=2)	± 4,7 dB for ANSI C63.4 measurement ± 0,5 dB for TIA-603 measurement
--	---

8.1 Limit §24.238

The rules in this section govern the spectral characteristics of emissions in the Broadband Personal Communications Service.

(a) *Out of band emissions.* The power of any emission outside of the authorized operating frequency ranges must be attenuated below the transmitting power (P) by a factor of at least $43 + 10 \log(P)$ dB.

(b) *Measurement procedure.* Compliance with these rules is based on the use of measurement instrumentation employing a resolution bandwidth of 1 MHz or greater. However, in the 1 MHz bands immediately outside and adjacent to the frequency block a resolution bandwidth of at least one percent of the emission bandwidth of the fundamental emission of the transmitter may be employed. A narrower resolution bandwidth is permitted in all cases to improve measurement accuracy provided the measured power is integrated over the full required measurement bandwidth (i.e. 1 MHz or 1 percent of emission bandwidth, as specified). The emission bandwidth is defined as the width of the signal between two points, one below the carrier center frequency and one above the carrier center frequency, outside of which all emissions are attenuated at least 26 dB below the transmitter power.

The limit is -13dBm (e.i.r.p).

8.2 Test method ANSI/TIA/EA-603-C

Measurement procedure. TIA-603-C

The antenna substitution method is used to determine the equivalent radiated power at spurious frequencies. The spurious emissions are measured at a distance of 3 meters. The EUT is then replaced with a reference substitution antenna with a known gain referenced to a dipole. This antenna is fed with a signal at the spurious frequency. The level of the signal is adjusted to repeat the previously measured level. The resulting eirp is the signal level fed to the reference antenna corrected for gain referenced to an isotropic dipole (see Figure 7.2).

From KDB (AMPLIFIER, BOOSTER, AND REPEATER REMINDER SHEET):

Radiated spurs (enclosure) – Use of CW signal (low, mid. and high freq.) is acceptable rather than all modulations.

The maximum RFI field strength was determined during the measurement by rotating the turntable (± 180 degrees) and varying the height of the receive antenna ($h = 1 \dots 4$ m) as like defined in ANSI C63.4. A measurement receiver has been used with a RBW 120 kHz up to 1 GHz and 1 MHz above 1 GHz. Steps with during pre measurement was half the RBW.

Both, the Fully Anechoic Chamber (FAC) and the Semi Anechoic Chamber (SAC) fulfil the requirements of ANSI C63.4 and CISPR 16-1-4 with regards to NSA and SVSWR.

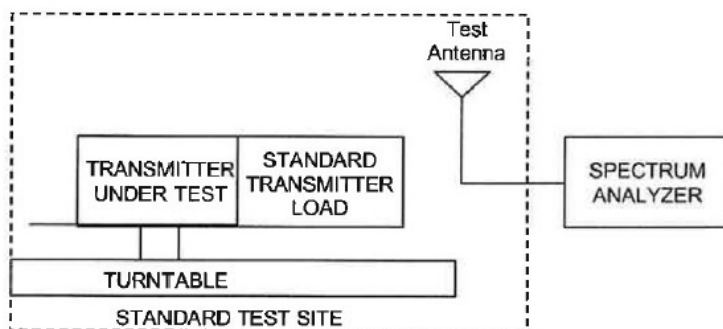

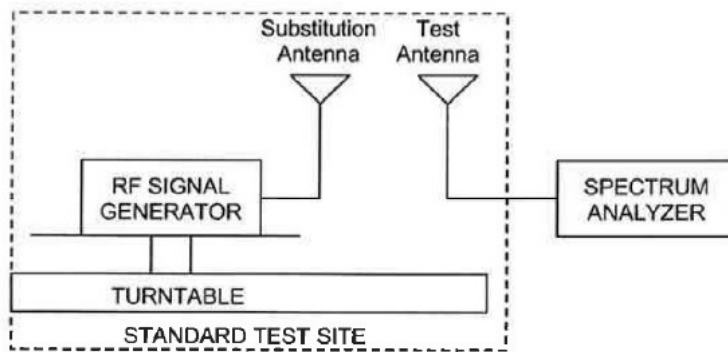

picture 8.3: Substitution method

8.3 Climatic values in the lab

Temperature: 19°
Relative Humidity: 40%
Air-pressure: 1005 hPa



8.4 Test results

8.4.1 Premeasurements

8.4.1.1 30 MHz to 1 GHz Downlink (Bottom – Middle – Top)

Bottom @ 1947,5 MHz:

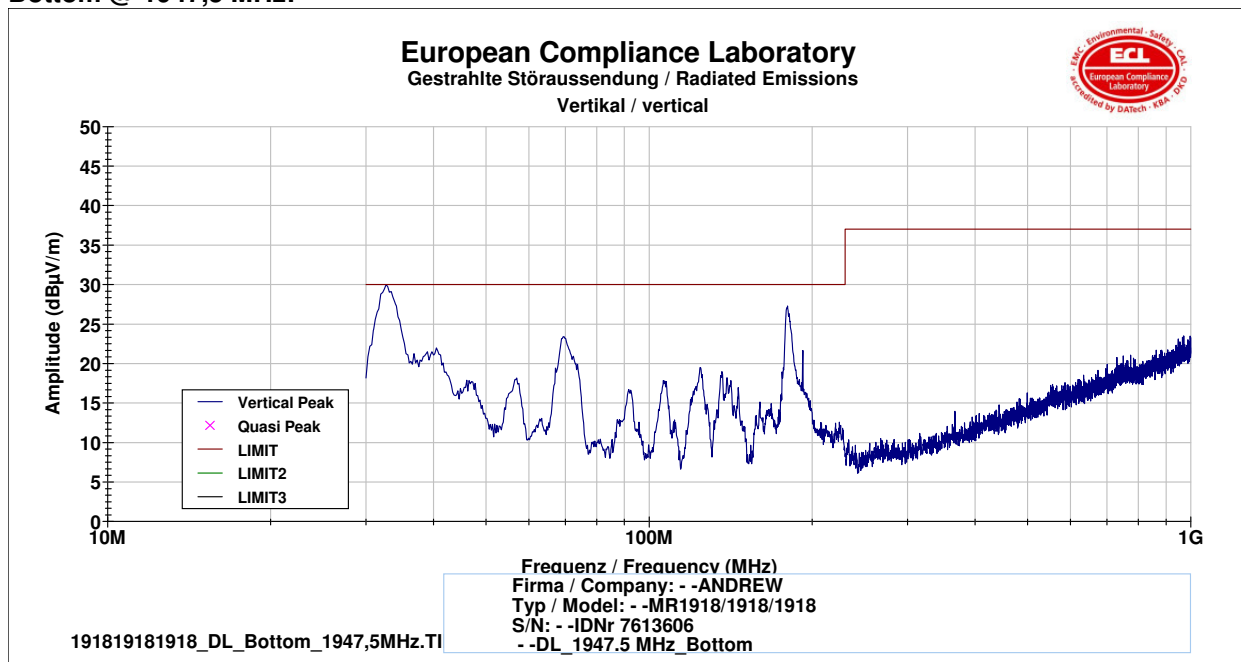



Middle @ 1960 MHz:

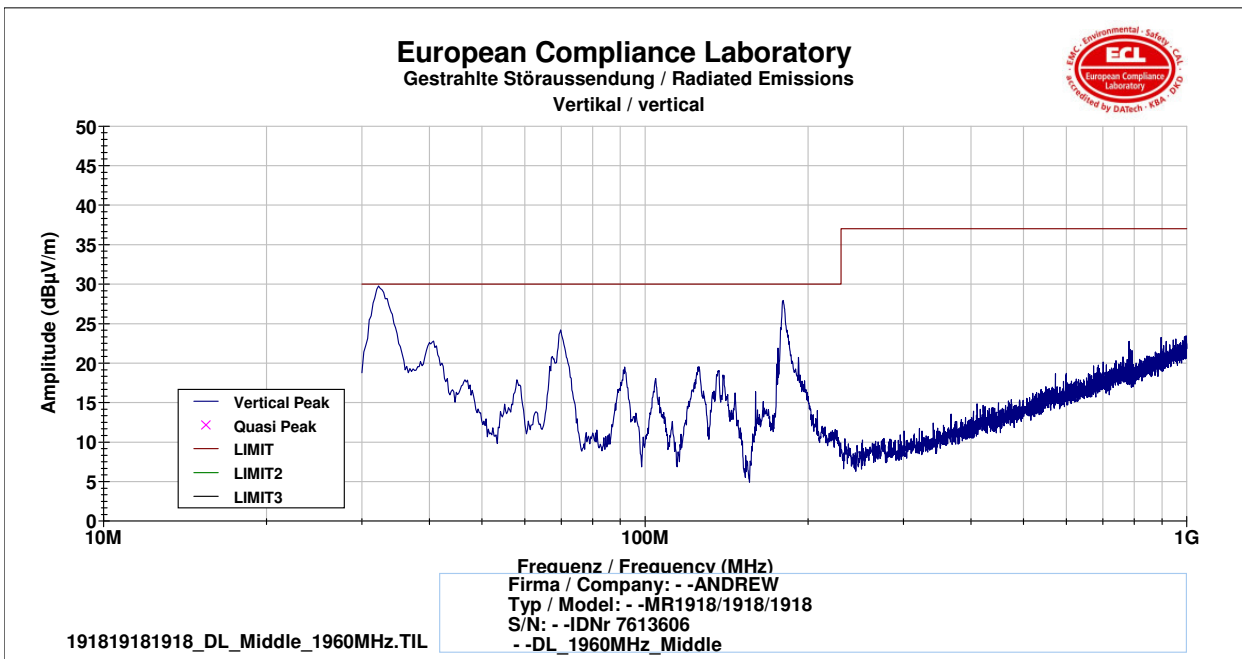
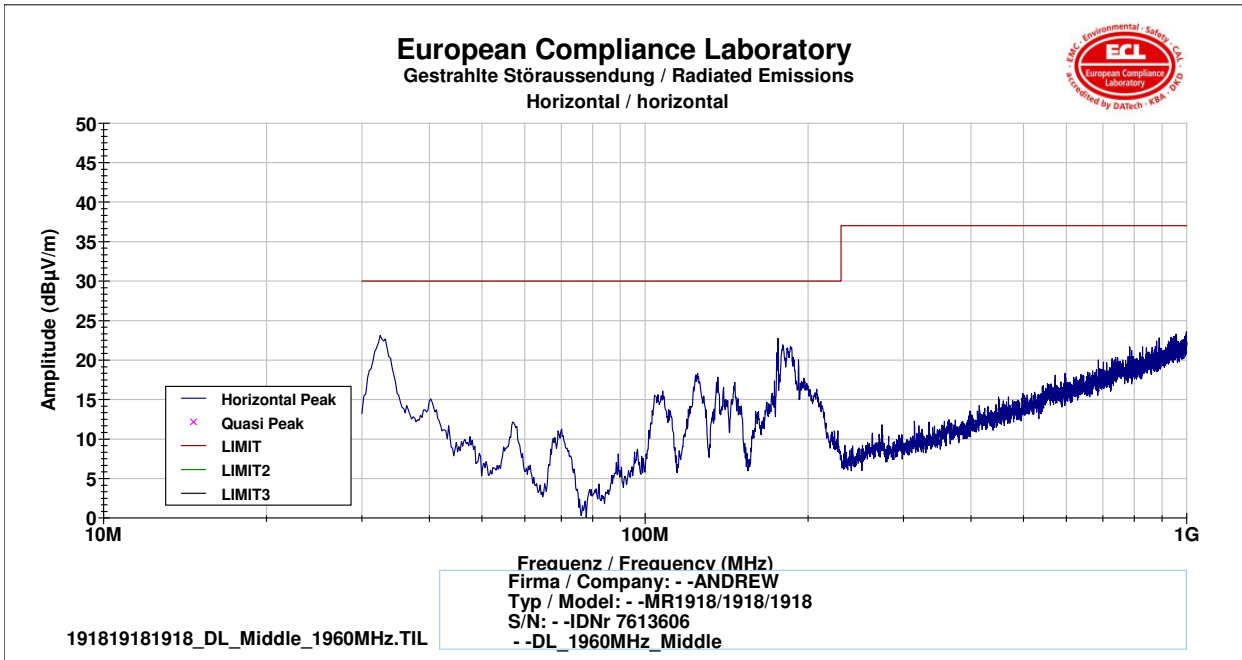



Top @ 1972,5 MHz:

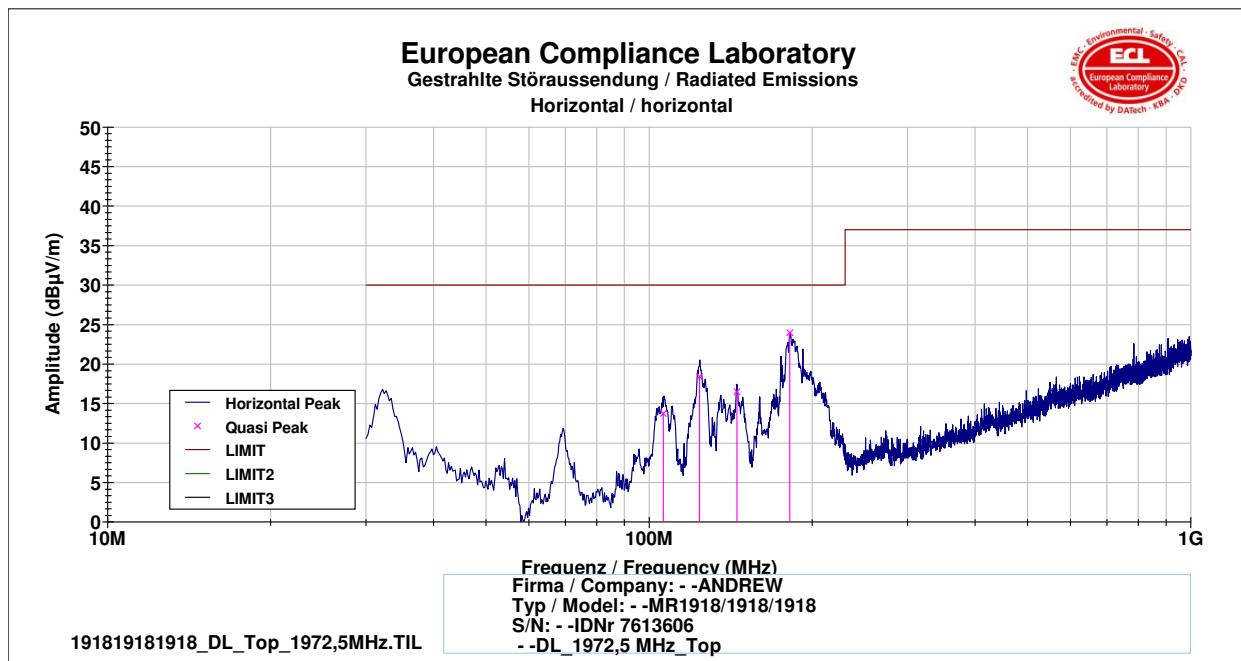

Frequency	Polarisation	Height	TT-Position	Cable Loss	Antenna Factor	Reading	Field Intensity	Limit	Margin
[MHz]	H/V	[cm]	[°]	(dB)	(dB/m)	(dBµV)	(dBµV/m)	(dBµV/m)	(dB)
106.241	H	311	-85	36.329	10.799	39.276	13.746	30.000	16.254
123.856	H	357	-106	36.178	12.254	42.327	18.403	30.000	11.597
145.235	H	347	122	36.142	10.984	41.647	16.488	30.000	13.512
181.929	H	387	-87	35.805	9.177	50.580	23.952	30.000	6.048

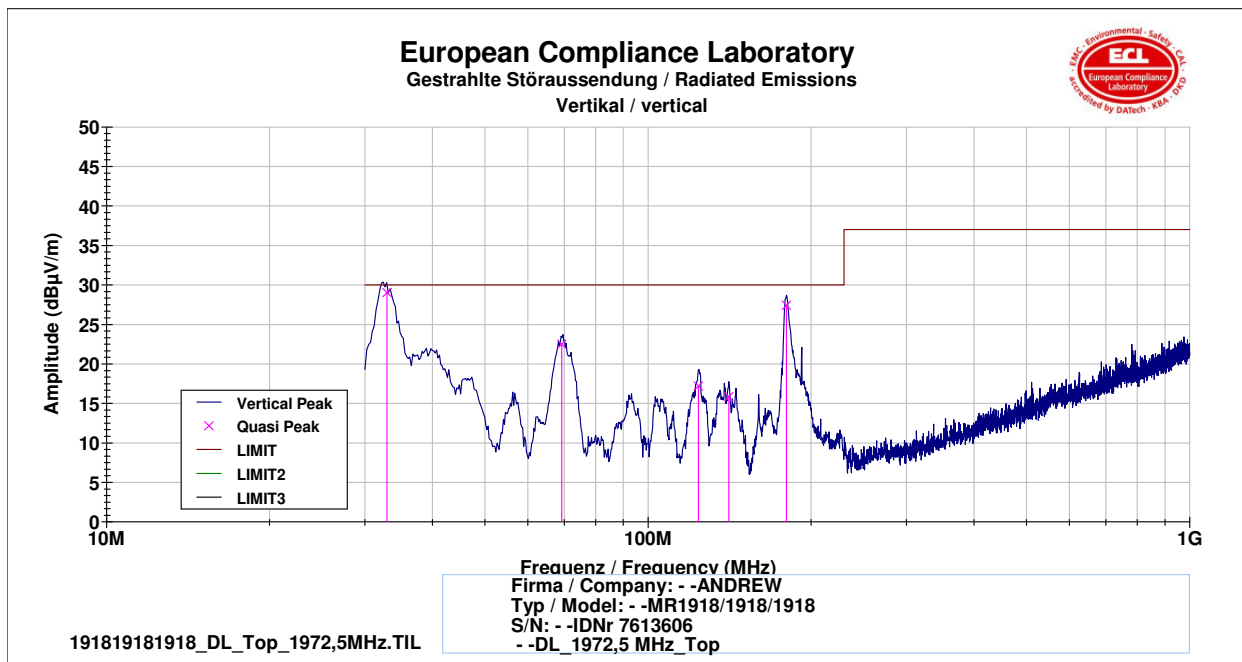

Frequency	Polarisation	Height	TT-Position	Cable Loss	Antenna Factor	Reading	Field Intensity	Limit	Margin
[MHz]	H/V	[cm]	[°]	(dB)	(dB/m)	(dBµV)	(dBµV/m)	(dBµV/m)	(dB)
32.9758	V	104	-137	37.130	16.012	50.155	29.037	30.000	0.963
69.3067	V	145	-83	36.636	6.064	53.061	22.489	30.000	7.511
123.856	V	107	-120	36.178	12.254	41.112	17.188	30.000	12.812
140.925	V	126	-105	36.154	11.163	40.833	15.843	30.000	14.157
180.105	V	108	86	35.818	9.104	54.132	27.417	30.000	2.583



8.4.1.2 30 MHz to 1 GHz Uplink (Bottom – Middle – Top)

Bottom @ 1867,5 MHz:

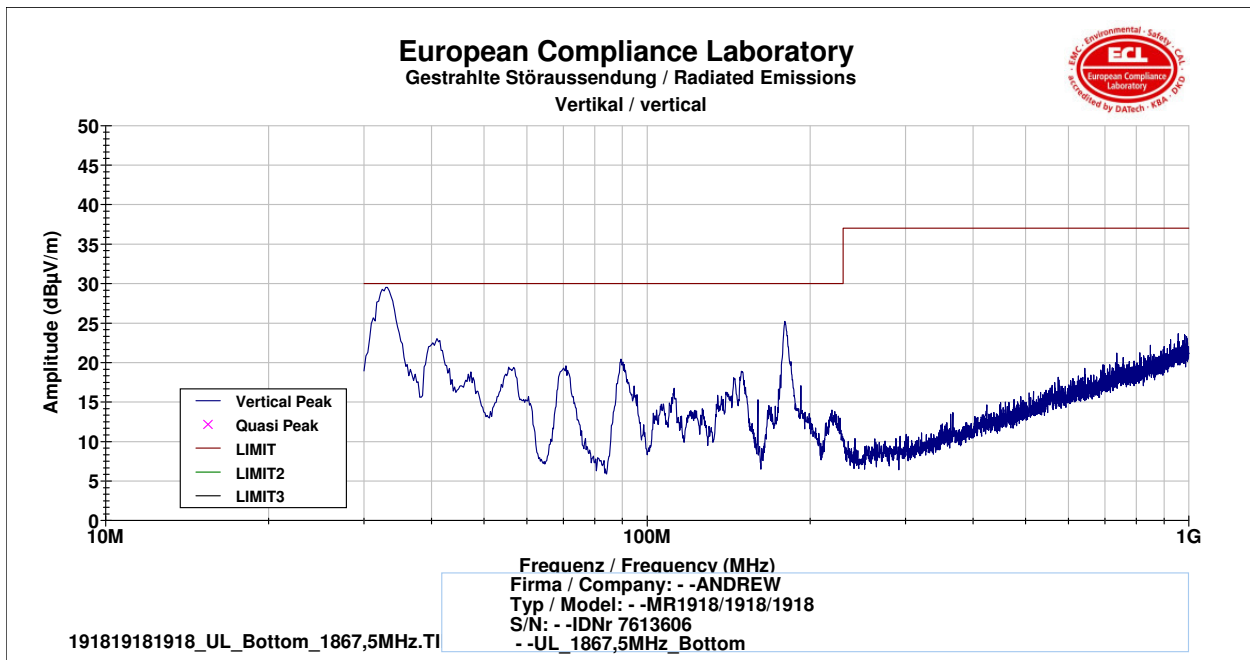
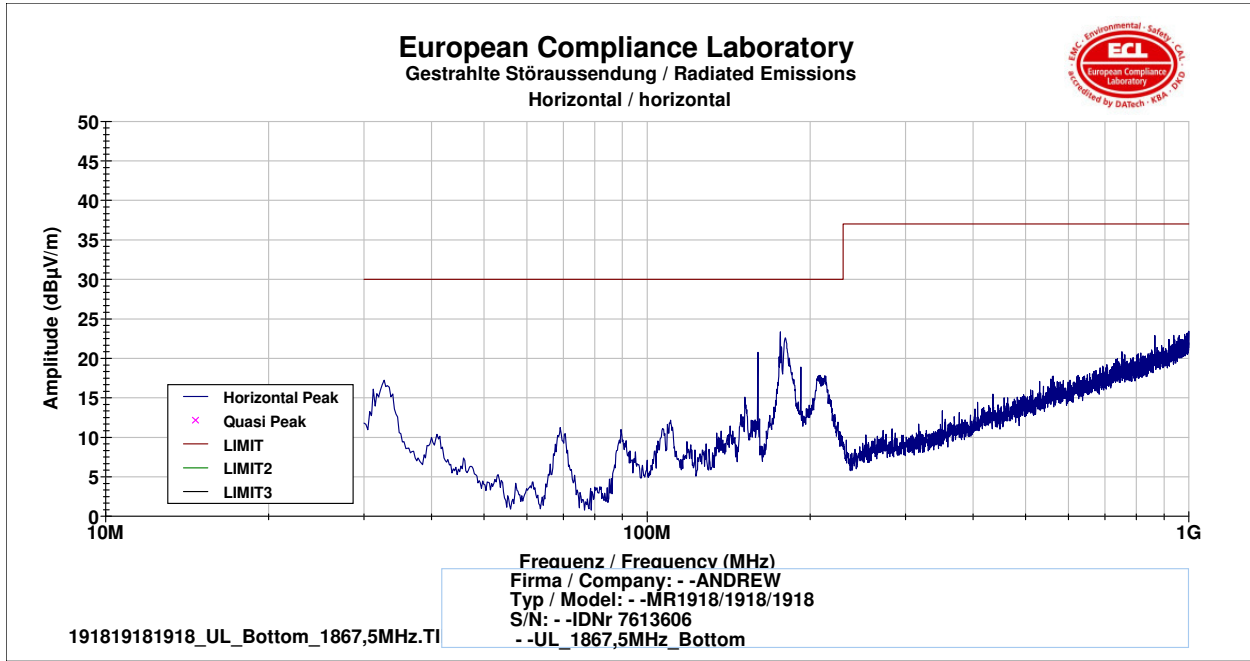



Frequency	Polarisation	Height	TT-Position	Cable Loss	Antenna Factor	Reading	Field Intensity	Limit	Margin
[MHz]	H/V	[cm]	[°]	(dB)	(dB/m)	(dBµV)	(dBµV/m)	(dBµV/m)	(dB)
33.0388	V	103	122	37.129	15.981	49.292	NAN	30.000	NAN
56.4285	V	255	17	36.777	5.989	NAN	NAN	30.000	NAN
70.5216	V	131	-35	36.625	6.383	NAN	NAN	30.000	NAN
89.6516	V	181	17	36.480	9.127	NAN	NAN	30.000	NAN

Middle @ 1880 MHz:

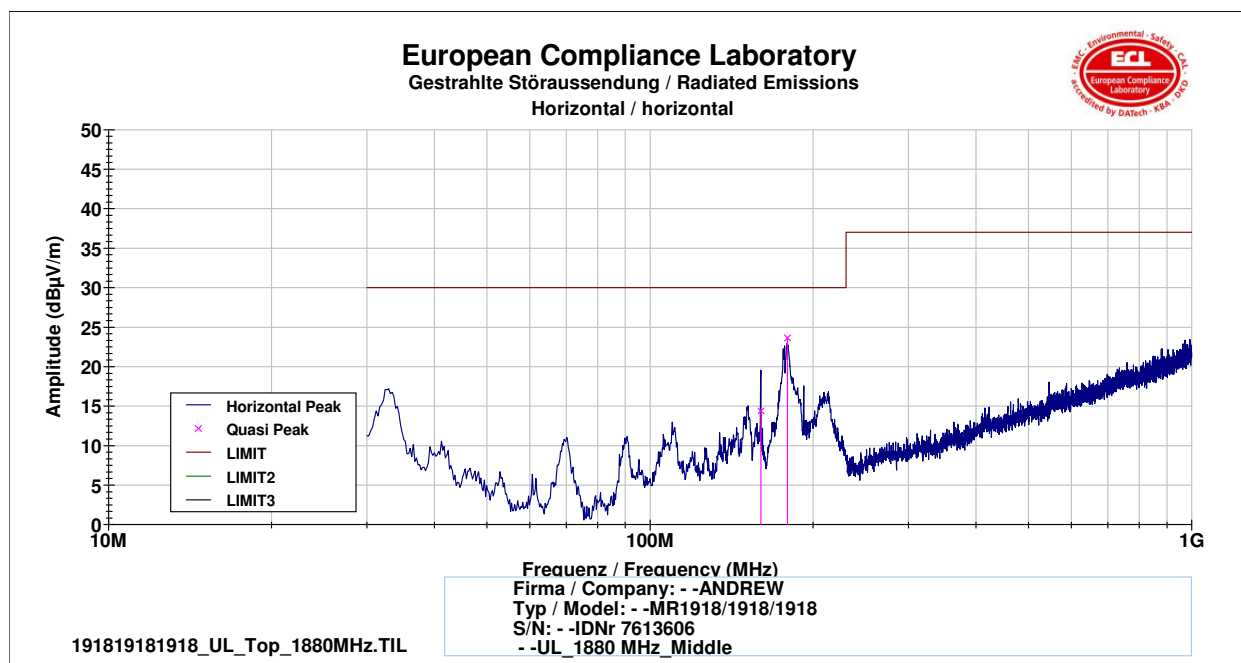

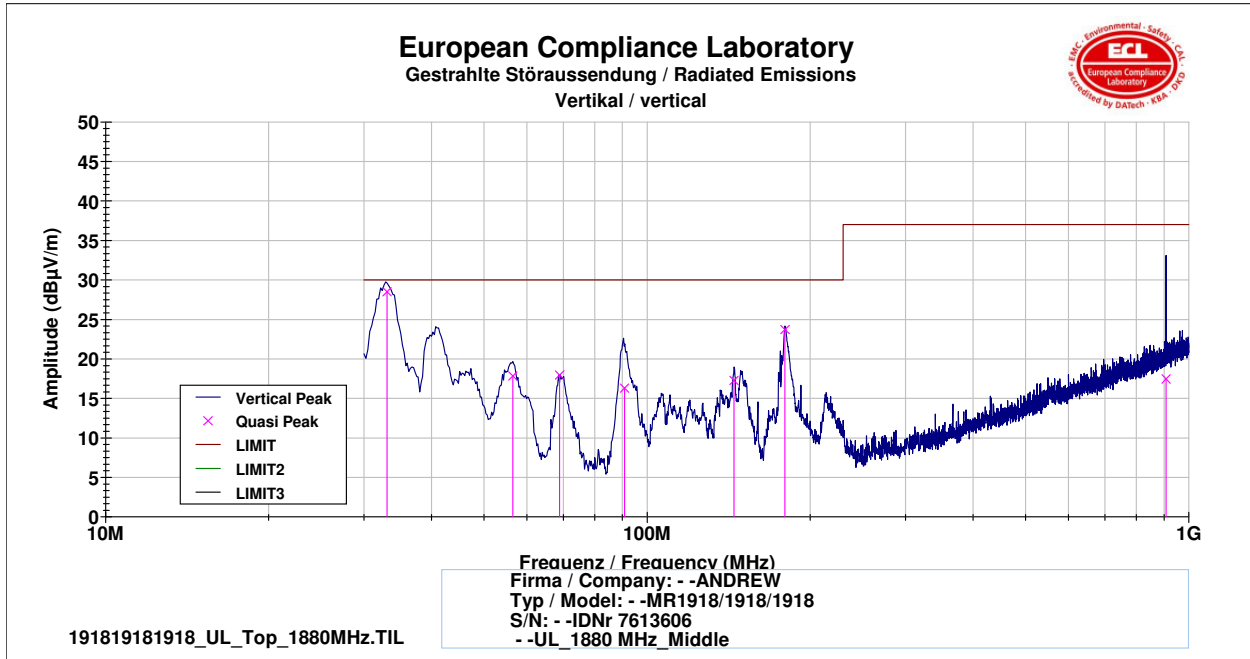

Top @ 1892,5 MHz:

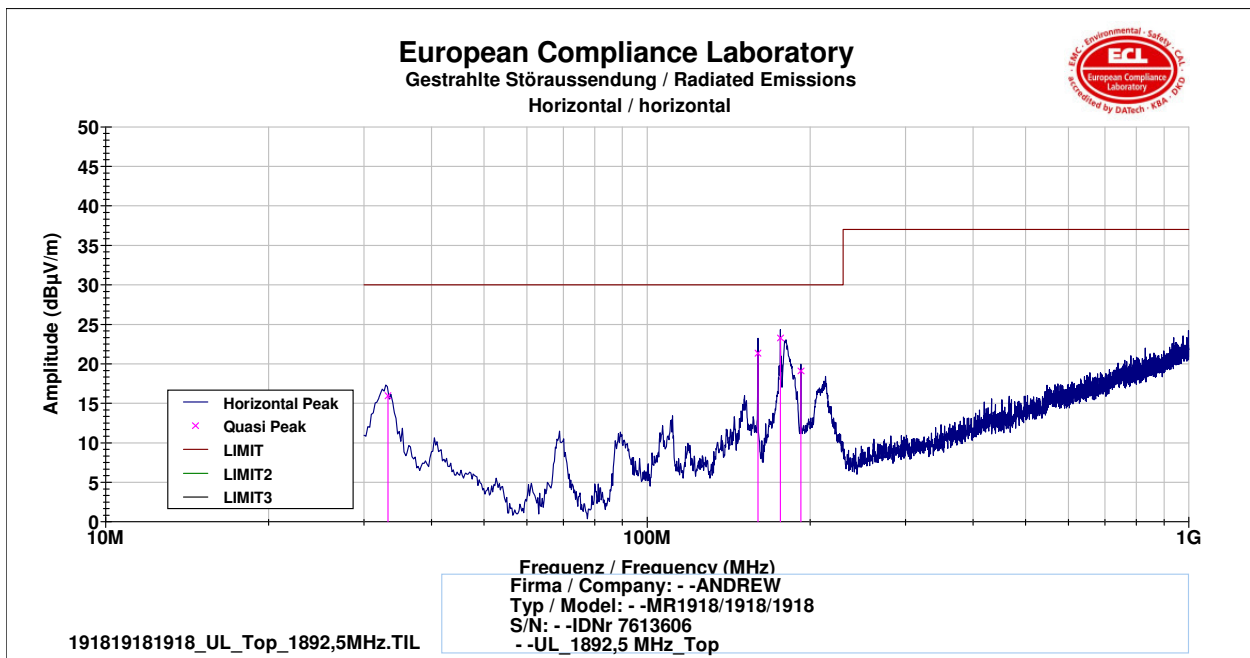



Frequency	Polarisation	Height	TT-Position	Cable Loss	Antenna Factor	Reading	Field Intensity	Limit	Margin
[MHz]	H/V	[cm]	[°]	(dB)	(dB/m)	(dBµV)	(dBµV/m)	(dBµV/m)	(dB)
33.2158	H	396	37	37.126	15.892	37.182	15.948	30.000	14.052
160.24	H	378	86	36.037	9.989	47.380	21.333	30.000	8.667
176.278	H	388	-121	35.860	9.268	49.852	23.259	30.000	6.741
192.315	H	396	-141	35.746	9.607	45.231	19.092	30.000	10.908

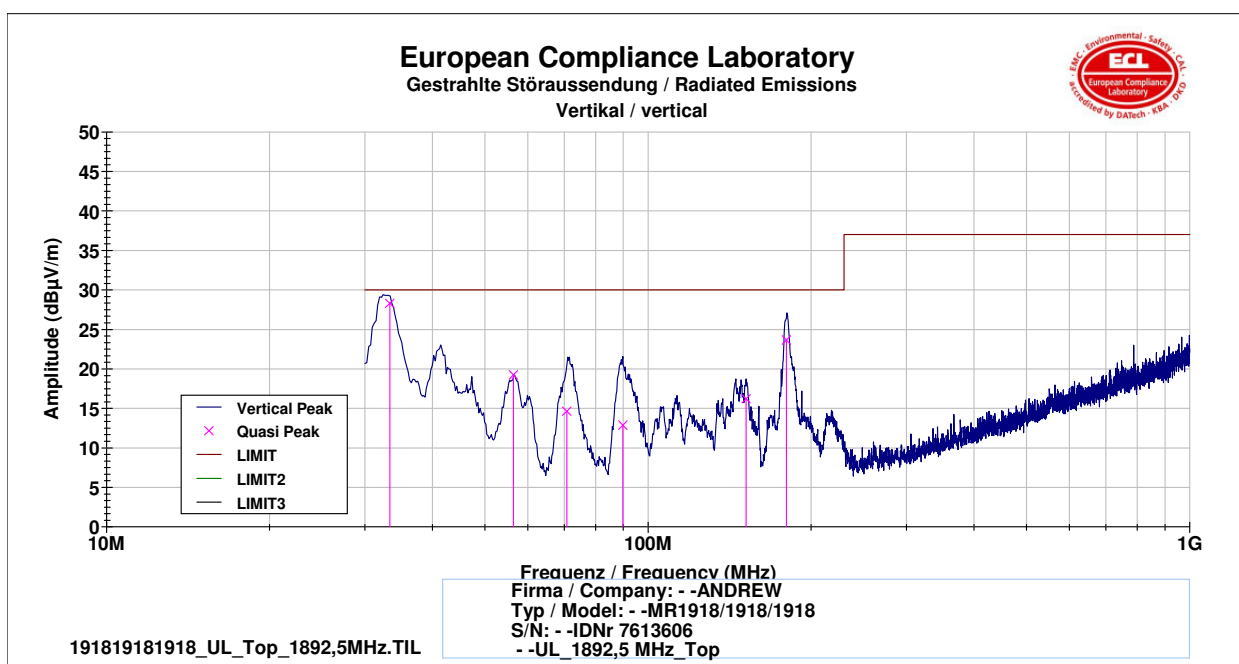

Frequency	Polarisation	Height	TT-Position	Cable Loss	Antenna Factor	Reading	Field Intensity	Limit	Margin
[MHz]	H/V	[cm]	[°]	(dB)	(dB/m)	(dBµV)	(dBµV/m)	(dBµV/m)	(dB)
33.3418	V	106	-16	37.124	15.829	49.584	28.289	30.000	1.711
56.4285	V	268	-152	36.777	5.989	50.021	19.233	30.000	10.767
70.7646	V	167	-68	36.623	6.422	44.823	14.623	30.000	15.377
89.8345	V	149	17	36.479	9.148	40.204	12.873	30.000	17.127
151.676	V	126	-136	36.119	10.533	41.808	16.222	30.000	13.778
180.108	V	107	86	35.818	9.104	50.356	23.642	30.000	6.358

8.4.1.3 20 GHz -22 GHz Downlink (Bottom – Middle – Top)

Bottom @ 1972,5 MHz **vertical**/**horizontal**:

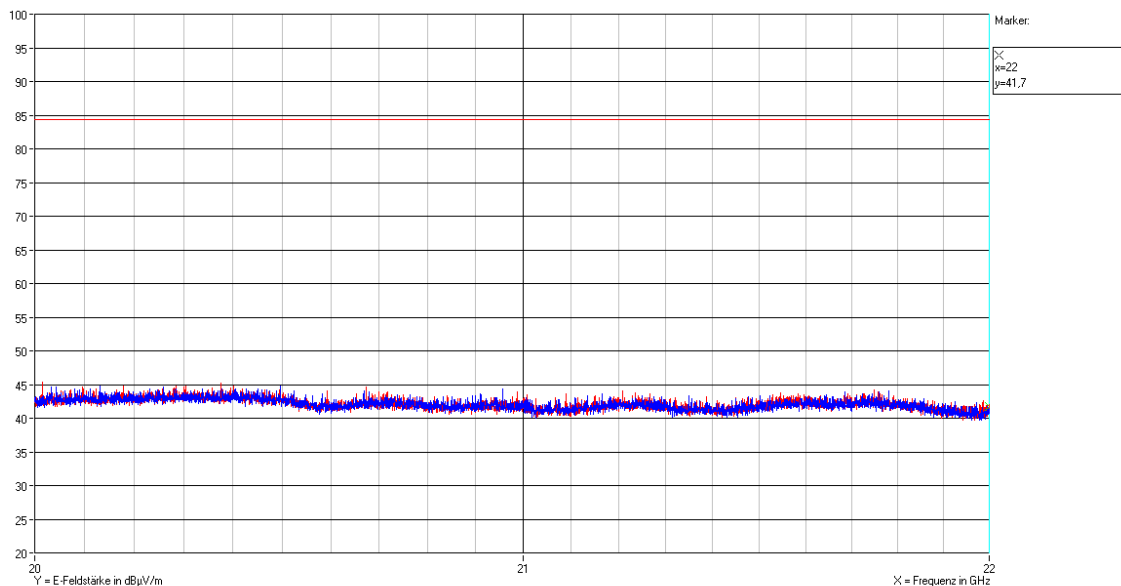

In all measurements there have been detected no signals above noise level. A plausibility check has been performed successfully after the first measurement in this frequency area.



8.4.2 Final measurements

8.4.2.1 30 MHz to 1 GHz

B/M/T DL/UL	Frequency	Polarisation	Height	TT-Position	e.i.r.p.	Limit	Margin
	[MHz]	H/V	[cm]	[°]	dBm	dBm	dB
DL/T	32.98	V	104	-137	-55.74	-13	42.74
DL/M	69.31	V	145	-83	-62.29	-13	49.29
UL/M	89.65	V	181	17	-62.28	-13	49.28
DL/T	106.24	H	311	-85	-71.03	-13	58.03
DL/T	123.86	H	357	-106	-66.38	-13	53.38
DL/T	140.93	V	126	-105	-68.94	-13	55.94
DL/T	145.24	H	347	122	-68.29	-13	55.29
UL/T	176.28	H	388	-121	-61.52	-13	48.52
DL/T	180.11	V	108	86	-57.36	-13	44.36

8.4.2.2 0,8 GHz to 20GHz Downlink

1947,5 MHz Bottom **horizontal**, **vertical**

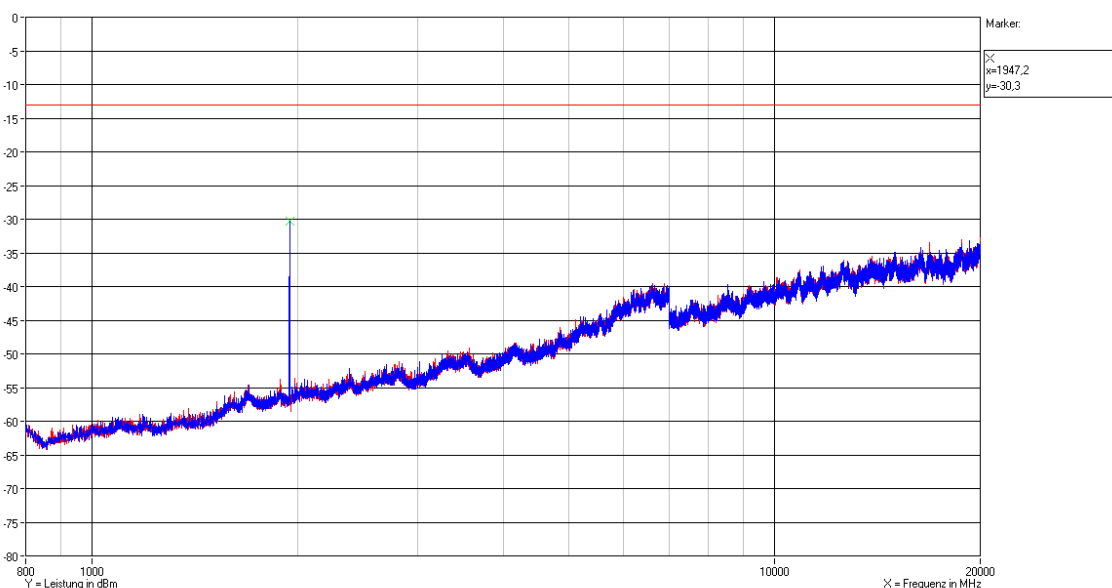



1960 MHz Middle **horizontal**, **vertical**

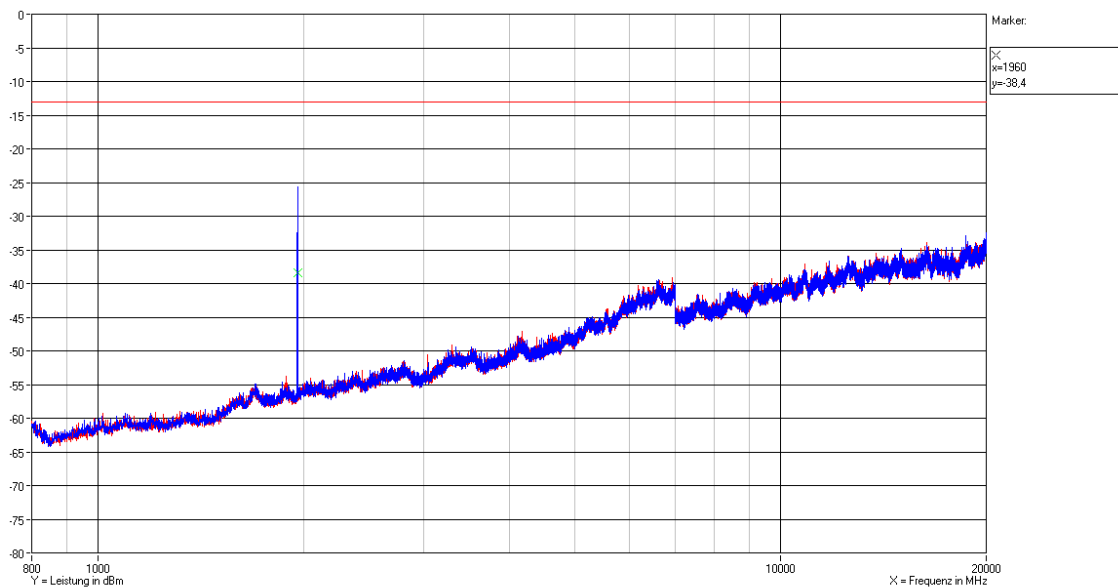

1972,5 MHz Top **horizontal**, **vertical**

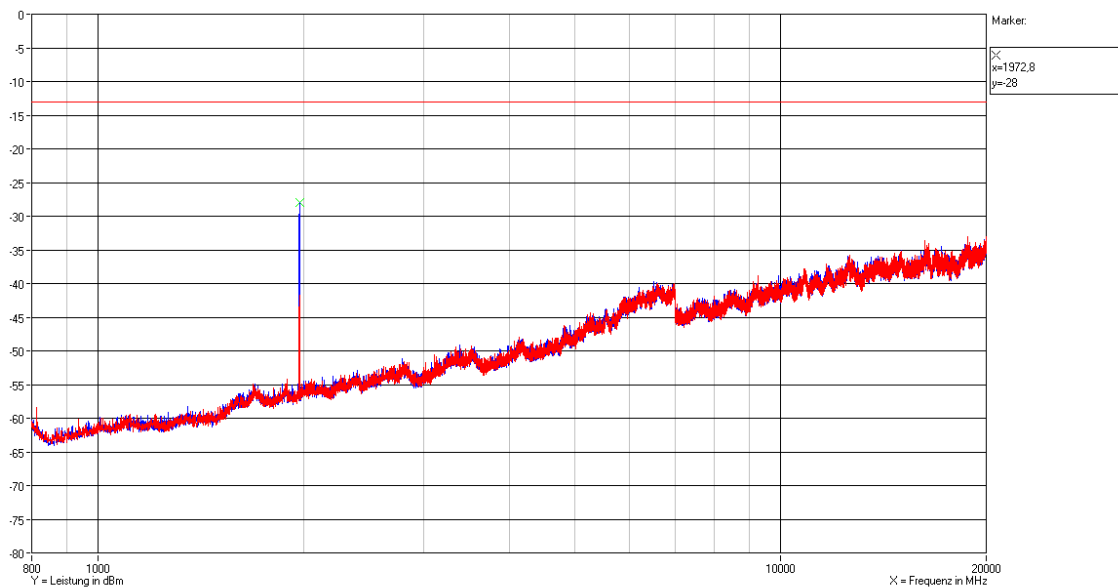



8.4.2.3 0,8 GHz to 20GHz Uplink

1867,5 MHz Bottom horizontal, vertical

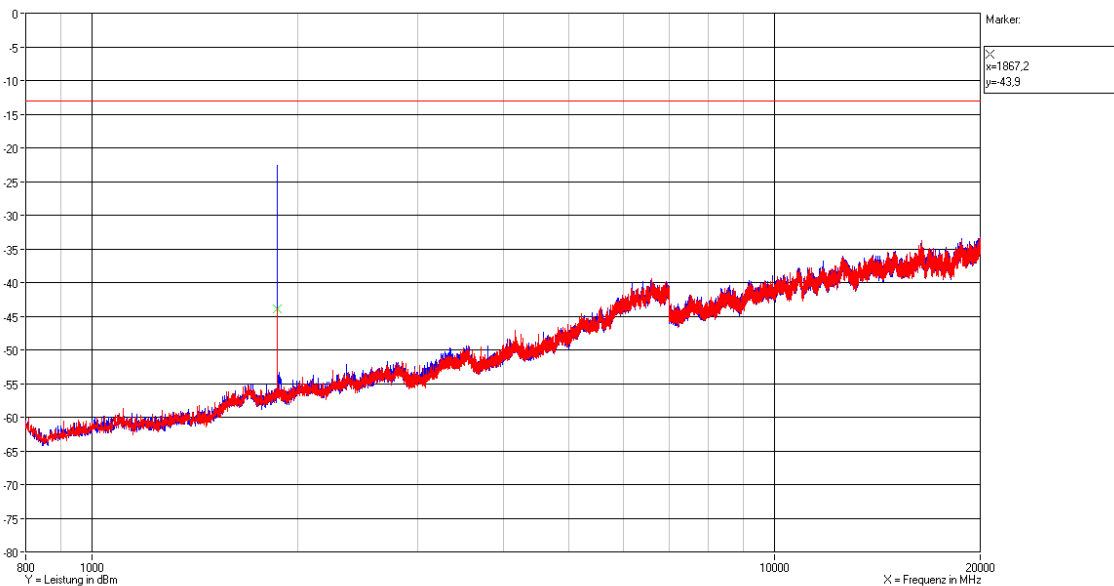

1880 MHz Middle horizontal, vertical

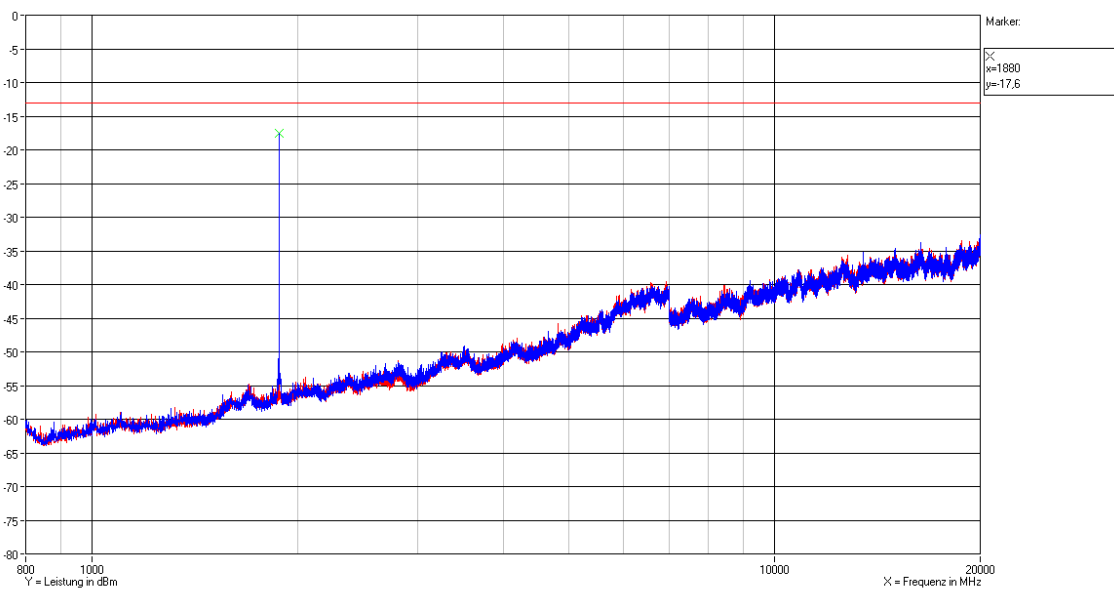



1892,5 MHz Top horizontal, vertical

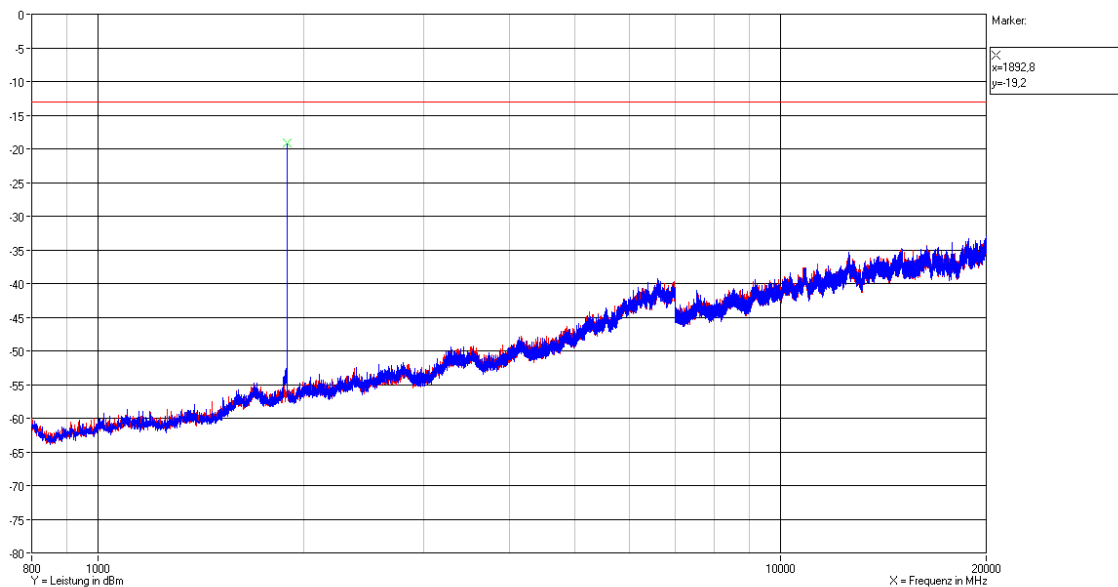

There were no spurious emissions detected other than noise and the fundamental.

8.4.2.4 20GHz to 22GHz

No substitution measurement has been performed, because there were no emissions detected during the pre measurement other than noise.

8.5 Summary test result

Test result	complies, according to the plots above
Tested by:	Mario Lehmann
Date:	04.04.2010

EMC Test Report No.: 10-035

FCC ID: XS5-MR191919

IC ID: 2237E-MR191919



9 History

Revision	Modification	Date	Name
V01.00	Initial Report	19.04.2010	Mario Lehmann

***** End of test report *****