

Test Site:  
FCC Test Site No.: 96997  
IC OATS No.: IC3475A-1



## ECL-EMC Test Report No.: 12-008

Equipment under test: ION-M7P/17P 1700MHz Path  
FCC ID: XS5-ML717P

Type of test: **FCC 47 CFR Part 27 Subpart C: 2011**  
Miscellaneous Wireless Communication Services  
**IC RSS-139:2009**  
Advanced Wireless Services Equipment Operating in  
the Bands 1710-1755 MHz and 2110-2155 MHz

Measurement Procedures: 47 CFR Parts 2 (*Frequency Allocations and Radio Treaty Matters; General Rules and Regulations*),  
Part 27:2011 (*Miscellaneous Wireless Communication Services*),  
ANSI/TIA-603-C (2004), *Land Mobile FM or PM Communications Equipment Measurement and Performance Standards*  
IC-GEN General Requirements and Information for the  
Certification of Radiocommunication Equipment

Test result: **Passed**

Date of issue:	26.01.12		Signature:
Issue-No.:	01	Author:	
Date of delivery:	24.01.12	Checked:	
Test dates:	01.04.11 – 24.01.12		
Pages:	35		



**Manufacturer:** ANDREW Wireless Systems GmbH  
Industriering 10

D-86675 Buchdorf

Tel.: +49 (0)9099 69 0

Fax: +49 (0)9099 69 140

**Test Location:** TEMPTON Service Plus GmbH  
European Compliance Laboratory (ECL)

Thurn-und-Taxis-Straße 18

D-90411 Nürnberg

Tel.: +49 (0) 911 59835 0

Fax: +49 (0) 911 59835 90

**General:**

The purpose of this report is to show compliance to the FCC regulations for devices operating under Part N 22,N°27 of the Code of Federal Regulations title 47.

This report informs about the results of the EMC tests, it only refers to the equipment under test. No part of this report may be reproduced in any form, without written permission.



## Table of contents

1	TEST RESULTS SUMMARY .....	5
2	EQUIPMENT UNDER TEST (E.U.T.) .....	6
2.1	DESCRIPTION .....	6
2.1.1	DOWNLINK .....	6
2.1.2	UPLINK .....	6
2.1.3	DESCRIPTION OF EUT .....	6
2.1.4	BLOCK DIAGRAM OF MEASUREMENT REFERENCE POINTS .....	7
3	TEST SITE (ANDREW BUCHDORF) .....	8
3.1	TEST ENVIRONMENT .....	8
3.2	TEST EQUIPMENT .....	8
3.3	INPUT AND OUTPUT LOSSES .....	8
3.4	MEASUREMENT UNCERTAINTY .....	8
4	TEST SITE (TEMPTON SERVICE PLUS GMBH) .....	9
5	RF POWER OUT: §27.50, §2.1046; RSS-139, RSS-GEN .....	10
5.1	LIMIT .....	10
5.2	TEST METHOD .....	10
5.3	TEST RESULTS .....	11
5.3.1	DOWNLINK .....	11
5.3.1.1	CDMA .....	12
5.3.1.2	W-CDMA .....	12
5.3.1.3	LTE .....	13
5.3.2	UPLINK .....	13
5.4	SUMMARY TEST RESULT .....	13
6	OCCUPIED BANDWIDTH: §2.1049; RSS-GEN .....	14
6.1	LIMIT .....	14
6.2	TEST METHOD .....	14
6.3	TEST RESULTS .....	14
6.3.1	DOWNLINK .....	14
6.3.1.1	CDMA .....	15
6.3.1.2	W-CDMA .....	16
6.3.1.3	LTE .....	17
6.3.2	UPLINK .....	18
6.4	SUMMARY TEST RESULT .....	18
7	SPURIOUS EMISSIONS AT ANTENNA TERMINALS: §27.53, §2.1051; RSS-139, RSS-GEN .....	19
7.1	LIMIT .....	19
7.2	TEST METHOD .....	19
7.3	TEST RESULTS .....	20
7.3.1	DOWNLINK .....	20
7.3.1.1	WCDMA < 1MHz to band edge .....	21
7.3.1.2	CDMA < 1MHz to band edge .....	22



**FCC ID: XS5-ML717P**

---

7.3.1.3	LTE < 1MHz to band edge.....	23
7.3.1.4	CDMA > 1MHz to band edge.....	24
7.3.1.5	W-CDMA > 1MHz to band edge.....	24
7.3.1.6	LTE > 1MHz to band edge.....	25
7.3.2	UPLINK.....	25
7.4	SUMMARY TEST RESULT.....	25
8	FIELD STRENGTH OF SPURIOUS EMISSIONS: §27.53, §2.1053, RSS-139.....	26
8.1	METHOD OF MEASUREMENT.....	29
8.2	LIMIT §27.53 (H).....	30
8.3	CLIMATIC VALUES IN THE LAB.....	30
8.4	TEST RESULTS.....	31
8.4.1	30 MHz TO 1 GHz DOWNLINK (BOTTOM – MIDDLE – TOP).....	31
8.4.2	30 MHz TO 1 GHz DOWNLINK (MIDDLE OF ALL CARRIER).....	32
8.4.3	1 GHz TO 22 GHz DOWNLINK (BOTTOM – MIDDLE – TOP).....	33
8.4.4	1 GHz TO 22 GHz DOWNLINK (MIDDLE OF ALL CARRIER).....	34
9	HISTORY.....	34



## 1 Test Results Summary

Name of Test	FCC Para. No.	FCC Method	FCC Spec.	Result
RF Power Output	27.50(d)	2.1046	1640 Watts/MHz	Complies
Occupied Bandwidth	2.1049	2.1049	Input/Output	Complies
Spurious Emissions at Antenna Terminals	27.53(h)	2.1051	-13dBm	Complies
Field Strength of Spurious Emissions	27.53(m)	2.1053 TIA/EA-603	-13dBm E.I.R.P	Complies
Frequency Stability	27.54	2.1055	Must stay in band	NA

Name of Test	IC Para. No.	IC Method	Result
RF Power Output	RSS-139 6.4	RSS-GEN 4.8	Complies
Occupied Bandwidth	RSS-Gen 4.6	RSS-GEN 4.6.1	Complies
Spurious Emissions at Antenna Terminals	RSS-139 6.5	RSS-GEN 4.9	Complies
Field Strength of Spurious Emissions	RSS-139 6.5	RSS-GEN 4.9 SRSP-513	Complies
Frequency Stability	RSS-139 6.3	RSS-GEN 4.7	NA

Frequency stability is not applicable because the device uses a common oscillator to up convert and down convert the RF signal. The EUT does not contain modulation circuitry, or frequency generation, therefore the test was not performed.



## 2 Equipment under test (E.U.T.)

### 2.1 Description

Kind of equipment	ION-M7P/17P	
Andrew Ident. Number	Id.No. 7629728-0004	
Serial no.(SN)	11	
Revision	00	
Software version and ID	n. a.	
Type of modulation and Designator	CDMA (F9W)	<input checked="" type="checkbox"/>
	W-CDMA (F9W)	<input checked="" type="checkbox"/>
	LTE (G7D)	<input checked="" type="checkbox"/>
Frequency Translation	F1-F1	<input checked="" type="checkbox"/>
	F1-F2	<input type="checkbox"/>
	N/A	<input type="checkbox"/>
Band Selection	Software	<input type="checkbox"/>
	Duplexer	<input checked="" type="checkbox"/>
	Full band	<input type="checkbox"/>

#### 2.1.1 Downlink

Pass band	2110 MHz – 2155 MHz
Max. composite output power based on one carrier per path (rated)	43,14 dBm = 20,61W
Gain*	10 dB @ Pout BTS of 33 dBm

\*see 2.1.5

#### 2.1.2 Uplink

Pass band	1710 MHz – 1755 MHz
Gain*	n.a.

\*see 2.1.5

Note: The EUT does not transmit over the air in the uplink direction.

#### 2.1.3 Description of EUT

ION-M7P/17P is a multi-band, multi-operator remote unit configuration used in conjunction with a master unit in the ION optical distribution system.

This system transports up to two frequency bands simultaneously (700 MHz, 1700/2100 MHz), providing a cost-effective solution for distributing capacity from one or more base stations.

The ION- M7P/17P Repeater consists of one 700 MHz path and one 1700 MHz path, with the intended use of simultaneous transmission. This Test Report describes only the approval of the 1700/2100 MHz path

### 2.1.4 Block diagram of measurement reference points

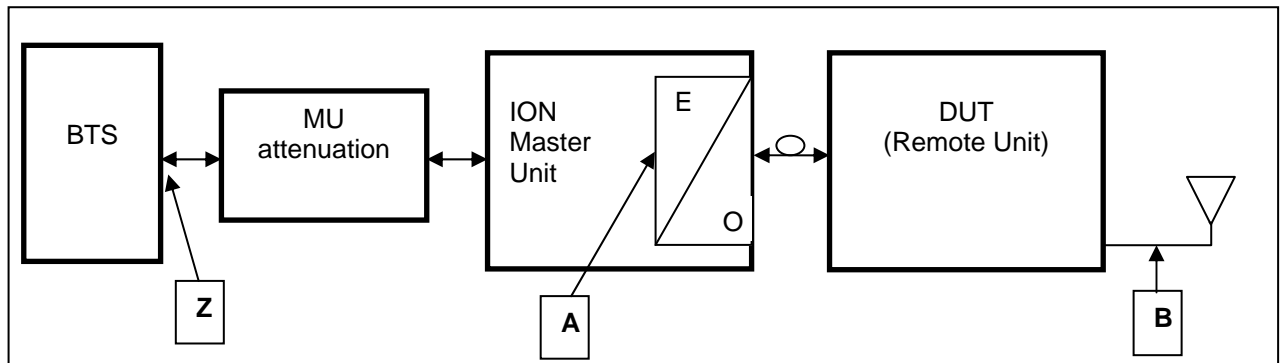

figure 2.1.4-#1 Block diagram of measurement reference points

Remote Unit is the DUT  
 O/E Optitcal/Electrical converter  
 SRMU SubRack Master Unit

Reference point A, SRMU UL output, DL input  
 Reference point B, Remote Unit DL output, UL input  
 Reference point Z, BTS DL output, BTS UL input  
 Since a signal generator does not supply a good output signal with +33 or +43dBm, for the downlink measurement the MU Attenuation is not used.  
 That means for downlink measurements the signal generator is connected to measurement point A at the master optical / electrical converter and the analyzer to the measurement point B at the RU.

### 3 Test site (Andrew Buchdorf)

#### 3.1 Test environment

All tests were performed under the following environmental conditions:

Condition	Minimum value	Maximum value
Barometric pressure	86 kPa	106 kPa
Temperature	15°C	30°C
Relative Humidity	20 %	75 %
Power supply range	±5% of rated voltages	

#### 3.2 Test equipment

ANDREW Inv. No.	Test equipment	Type	Manufacturer	Serial No.	Calibration
8372	Network Analyzer	8753D	HP	3410A08675	02/11
8961	Spectrum Analyzer	FSP-13	R&S	100147/013	10/11
8798	Spectrum Analyzer	FSQ-26	R&S	100340	03/2012
8849	Signal Generator	SMU200A	R&S	101732	04/11
8856	Signal Generator	SMIQ 03B	R&S	100435	12/11
7192	Power Attenuator	769-30	Narda	07448	CIU
7338	Power Attenuator	769-10	Narda	05773	CIU
7191	Power Attenuator	765-20	Narda	0012	CIU
7119	Divider	2way	Mikom	3512	CIU
7287	RF-Cable	2,0m; N-N	Huber & Suhner	28441/4PEA	CIU
7288	RF-Cable	2,0m; N-N	Huber & Suhner	28442/4PEA	CIU
7391	RF-Cable	1,0m; SMA	Huber & Suhner	40447/4P	CIU
7391	RF-Cable	0,5m; SMA	Huber & Suhner	40225/4P	CIU

CIU = Calibrate in use

#### 3.3 Input and output losses

All recorded power levels should be referenced to the input and output connectors of the repeater, unless explicitly stated otherwise.

The test equipment used in this test has to be calibrated, so that the functionality is also checked.

All cables, attenuators, splitter, isolator, circulator and combiner etc. must be measured before testing and used for compensation during testing.

#### 3.4 Measurement uncertainty

The extended measurement uncertainty corresponds to the measurement results from the standard measurement uncertainty multiplied by the coverage factor  $k=2$ . The true value is located in the corresponding interval with a probability of 95 %.





#### **4 Test site (TEMPTON Service Plus GmbH)**

FCC Test site: 96997

IC OATS: IC3475A-1

**See relevant dates under section 8.**

## 5 RF Power Out: §27.50, §2.1046; RSS-139, RSS-GEN

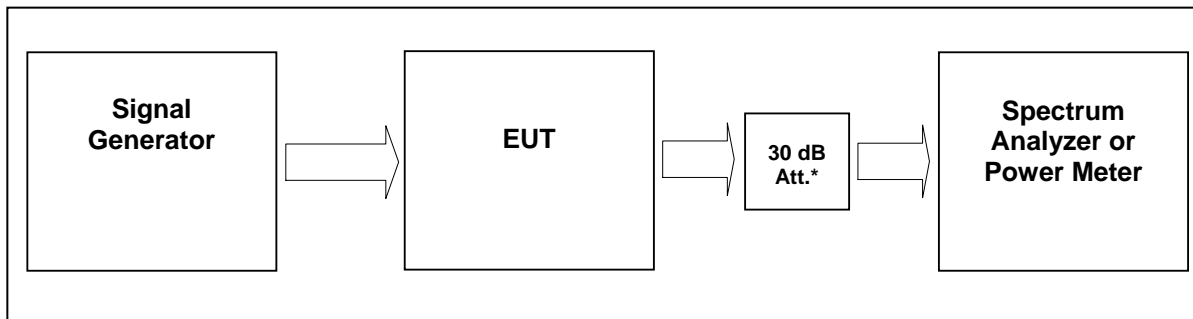

figure 3.4-#1 Test setup: RF Power Out: §27.50, §2.1046; RSS-139, RSS-GEN

Measurement uncertainty	± 0,38 dB
Test equipment used	8890; 8667; 8668; 8848; 7355;

### 5.1 Limit

Minimum standard:

Para. No.27.50(d)(2)(B)

(d) The following power and antenna height requirements apply to stations transmitting in the 1710–1755 MHz and 2110–2155 MHz bands:

(2) The power of each fixed or base station transmitting in the 2110–2155 MHz band and situated in any geographic location other than that described in paragraph (d)(1) is limited to:

(B) an EIRP of 1640 watts/MHz when transmitting with an emission bandwidth greater than 1 MHz.

### 5.2 Test method

§ 2.1046 Measurements required: RF power output.

(a) For transmitters other than single sideband, independent sideband and controlled carrier radiotelephone, power output shall be measured at the RF output terminals when the transmitter is adjusted in accordance with the tune-up procedure to give the values of current and voltage on the circuit elements specified in § 2.1033(c)(8). The electrical characteristics of the radio frequency load attached to the output terminals when this test is made shall be stated.

(c) For measurements conducted pursuant to paragraphs (a) and (b) of this section, all calculations and methods used by the applicant for determining carrier power or peak envelope power, as appropriate, on the basis of measured power in the radio frequency load attached to the transmitter output terminals shall be shown. Under the test conditions specified, no components of the emission spectrum shall exceed the limits specified in the applicable rule parts as necessary for meeting occupied bandwidth or emission limitations



### 5.3 Test results

Detector RMS.

#### Test signal CDMA

Signal waveform according to table 6.2-1 of standard specification 3GPP2 C.p0051-0 v1.0 16.February 2006 pilot, sync, paging, 37 traffics, which is equal to the table 6.5.2.1 of 3GPP2 C.S0010-C v2.0 24.February 2006.

#### Test signal WCDMA

Signal waveform according to Test Model 1 of standard specification 3GPP TS25.141. Signal modulated with a combination of PCCPCH, SCCPCH and Dedicated Physical Channels specified as test model 1 64 DPCH.

#### Test signal LTE:

Signal waveform according to Test Model 1.1, E-TM1.1, clause 6.1.1.1-1, table 6.1.1.1-1 of standard specification 3GPP TS 36.141 V9.3.0 (2010-03).

#### 5.3.1 Downlink

Modulation	Measured at	RBW VBW Span	RF Power (dBm)	RF Power (W)	Plot -
CDMA	2132,5 MHz	3MHz 10MHz 15MHz	43,14	20,61	5.3.1.1 #1
WCDMA	2132,5 MHz	10MHz 10MHz 50MHz	43,01	20,00	5.3.1.2 #1
LTE	2132,5 MHz	3MHz 10MHz 50MHz	43,04	20,14	5.3.1.3 #1
Maximum output power = 43,14 dBm -> 20,61W					
Limit Maximum output power = 1640 W -> 64,30 dBm					

table 5.3.1-#1 RF Power Out: §27.50, §2.1046; RSS-139, RSS-GEN Test results Downlink

The max RF Power out is 43.14 dBm, so the maximum antenna gain (x) can be calculated as follow:

**Limit = 1000W (erp) = 60 dBm**

Info: 1000W (erp) = 1640W (eirp)

60 dBm > 43.14 dBm + x

**16.86 dBd = 19.01 dBi > x**

=> The antenna that will use for the complete system have to have a gain lower than 19 dBi, relative to an isotropic antenna.

Modulation	Pin / dBm (Ref. point B)
CDMA	2,9
WCDMA	3,0
LTE	3,0

table 5.3.1-#2 RF Power Out: §27.50, §2.1046; RSS-139, RSS-GEN Test results Downlink Input power



FCC ID: XS5-ML717P

### 5.3.1.1 CDMA

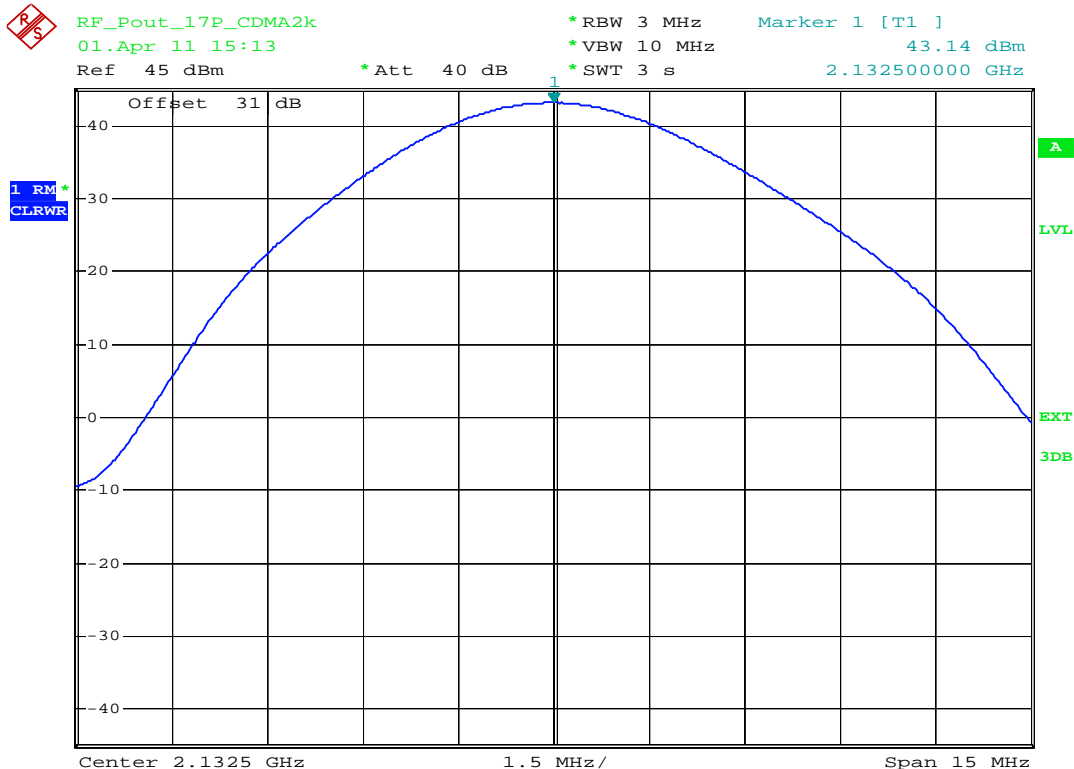

plot 5.3.1.1-#1 RF Power Out: §27.50, §2.1046; RSS-139, RSS-GEN; Test results; Downlink; CDMA Middle

### 5.3.1.2 W-CDMA

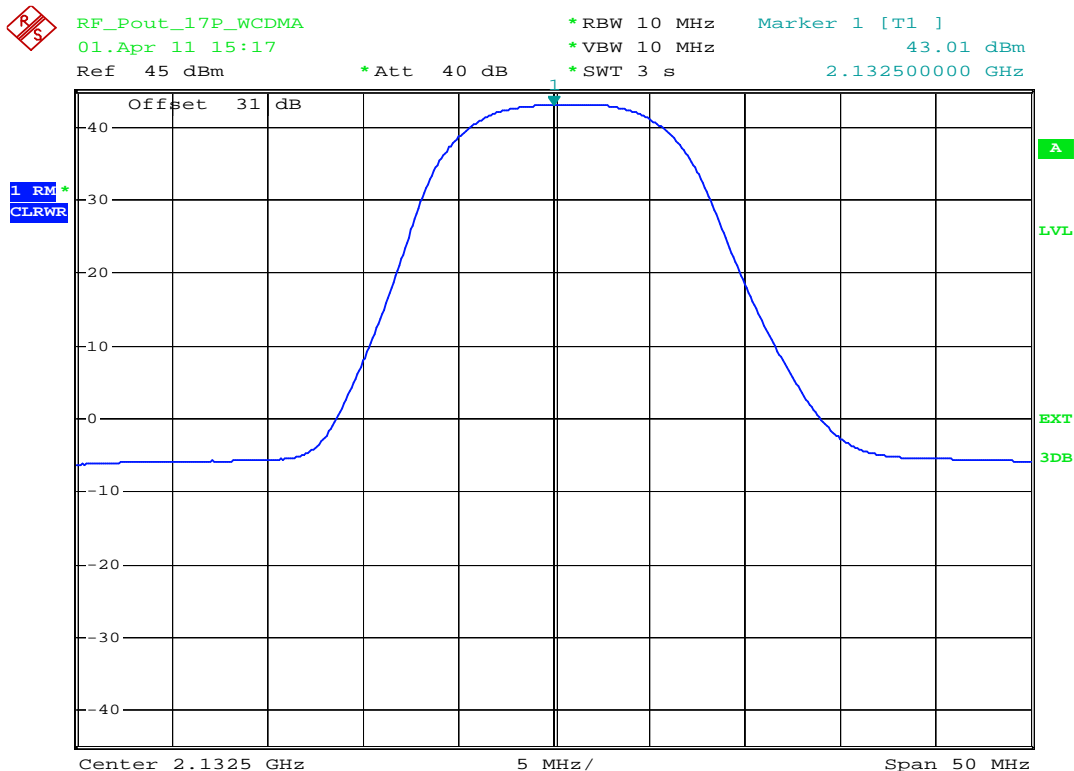

plot 5.3.1.2-#1 RF Power Out: §27.50, §2.1046; RSS-139, RSS-GEN; Test results; Downlink; W-CDMA Middle



FCC ID: XS5-ML717P

5.3.1.3 LTE

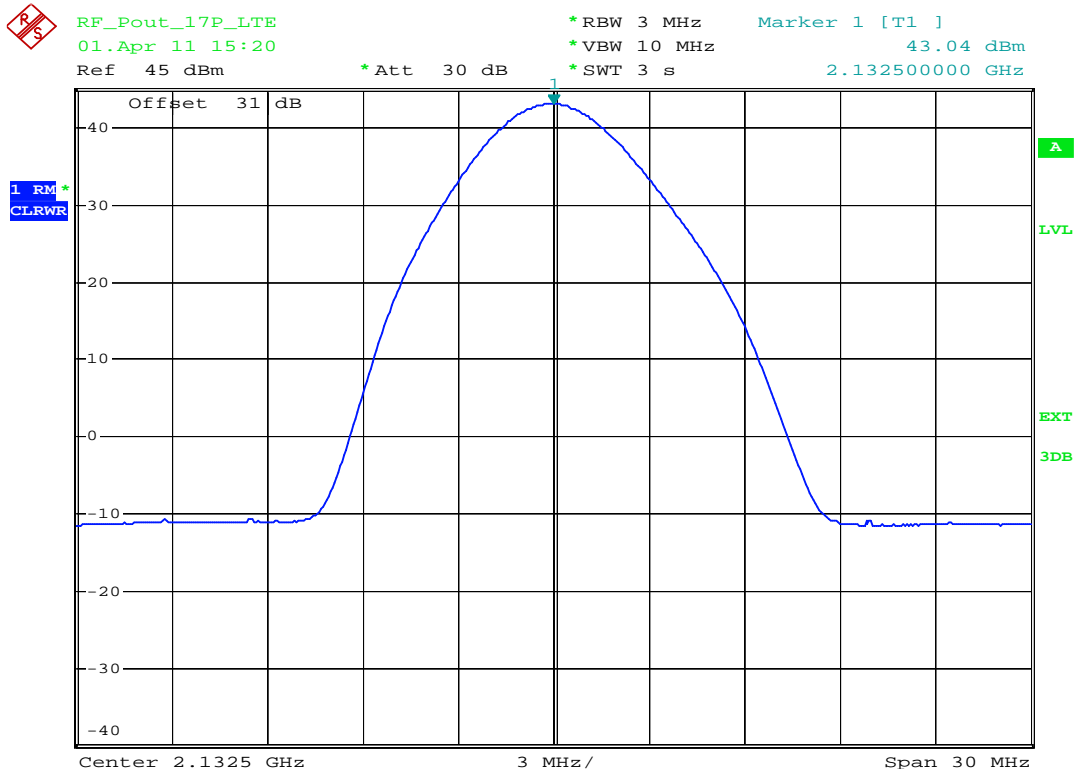

plot 5.3.1.3-#1 RF Power Out: §27.50, §2.1046; RSS-139, RSS-GEN; Test results; Downlink; LTE Middle

5.3.2 Uplink

n.a.

Note: The EUT does not transmit over the air in the uplink direction.

5.4 Summary test result

Test result	complies, according the plots above
Tested by:	L.Oskerko
Date:	01.04.2011



## 6 Occupied Bandwidth: §2.1049; RSS-GEN

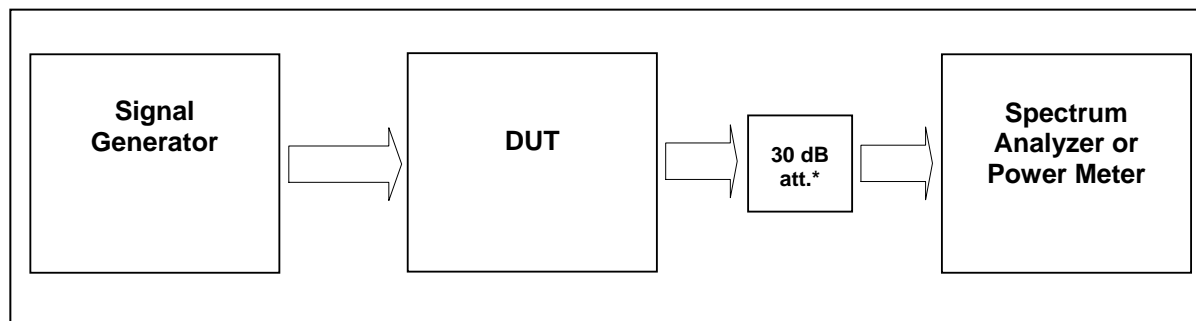

figure 5.4-#1 Test setup: Occupied Bandwidth: §2.1049; RSS-GEN

Measurement uncertainty	± 0,38 dB
Test equipment used	8890; 8667; 8668; 8848; 7355;

### 6.1 Limit

The spectral shape of the output should look similar to input for all modulations.

### 6.2 Test method

Para. No.2.1049

The occupied bandwidth, that is the frequency bandwidth such that, below its lower and above its upper frequency limits, the mean powers radiated are each equal to 0.5 percent of the total mean power radiated by a given emission shall be measured under the following conditions as applicable:

(h) Transmitters employing digital modulation techniques—when modulated by an input signal such that its amplitude and symbol rate represent the maximum rated conditions under which the equipment will be operated. The signal shall be applied through any filter networks, pseudo-random generators or other devices required in normal service. Additionally, the occupied bandwidth shall be shown for operation with any devices used for modifying the spectrum when such devices are optional at the discretion of the user.

### 6.3 Test results

#### 6.3.1 Downlink

Detector RMS.

Modulation	Measured at	Fcenter / MHz	RBW VBW Span	Occupied Bandwidth / MHz	Plot #
CDMA	Middle	2132,5	30kHz 300kHz 5MHz	1,24	6.3.1.1 #1, #2
WCDMA	Middle	2132,5	100kHz 1MHz 10MHz	4,17	6.3.1.2 #1, #2
LTE	Middle	2132,5	30 kHz 300 kHz 5 MHz	1,10	6.3.1.3 #1,#2

table 6.3-#1 Occupied Bandwidth: §2.1049; RSS-GEN Test results Downlink



FCC ID: XS5-ML717P

6.3.1.1 CDMA

⚠ OccupBW\_17P\_CDMA2k      \*RBW 30 kHz      Marker 1 [T1 ]  
 04.Apr 11 13:04      \*VBW 300 kHz      28.30 dBm  
 Ref 43.9 dBm      \*Att 30 dB      \*SWT 9 s      2.132500000 GHz

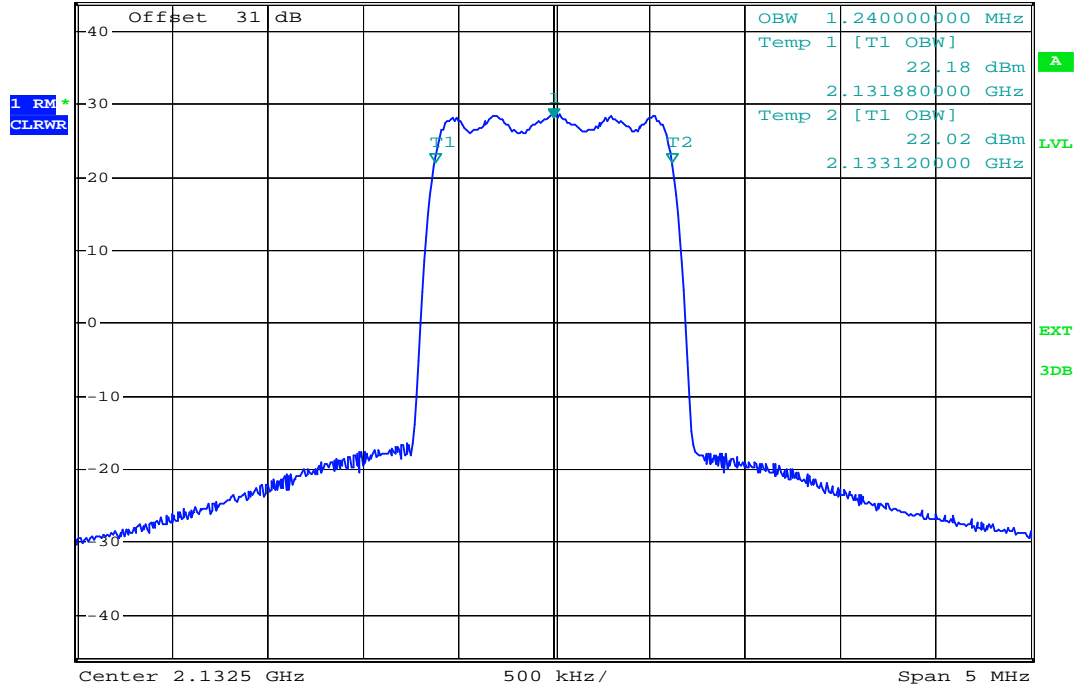

plot 6.3.1.1-#1 Occupied Bandwidth: §2.1049; RSS-GEN; Test results; Downlink; CDMA Output

⚠ OccupBW\_17P\_CDMA2k      \*RBW 30 kHz      Marker 1 [T1 ]  
 04.Apr 11 13:05      \*VBW 300 kHz      -14.22 dBm  
 Ref 10 dBm      Att 10 dB      \*SWT 9 s      2.132500000 GHz

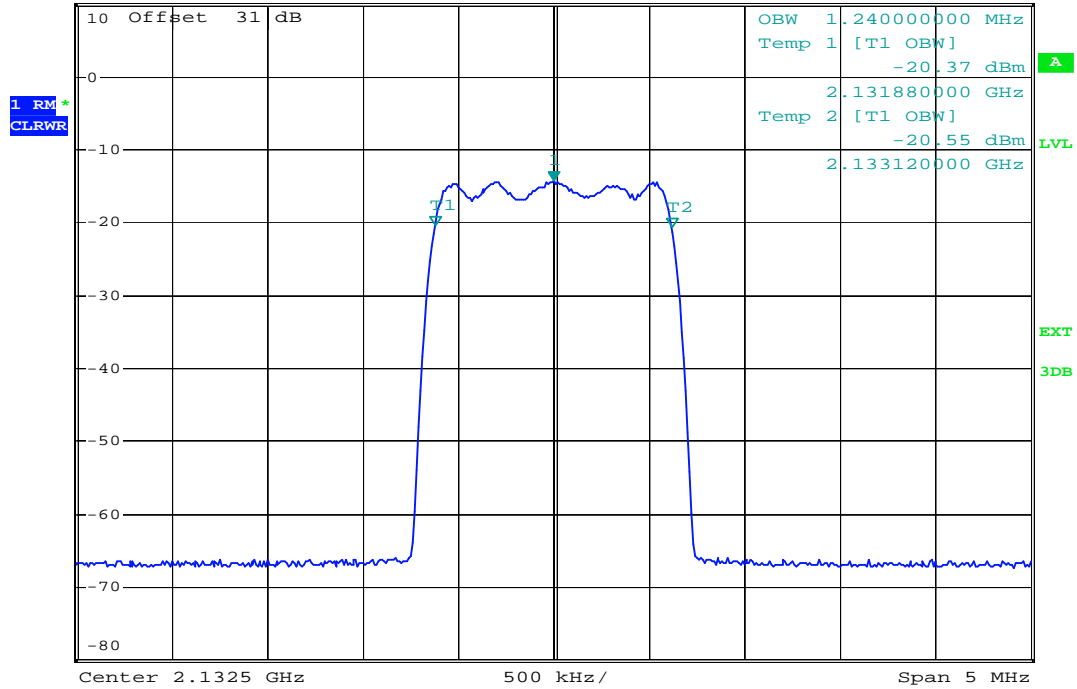

plot 6.3.1.1-#2 Occupied Bandwidth: §2.1049; RSS-GEN; Test results; Downlink; CDMA Input



FCC ID: XS5-ML717P

### 6.3.1.2 W-CDMA



OccupBW\_17P\_WCDMA  
04.Apr 11 13:14

\*RBW 30 kHz    Marker 1 [T1 ]  
\*VBW 300 kHz    22.70 dBm  
\*SWT 9 s    2.13250000 GHz

Ref 46.9 dBm    \*Att 30 dB

1 RM\*  
CLRWR

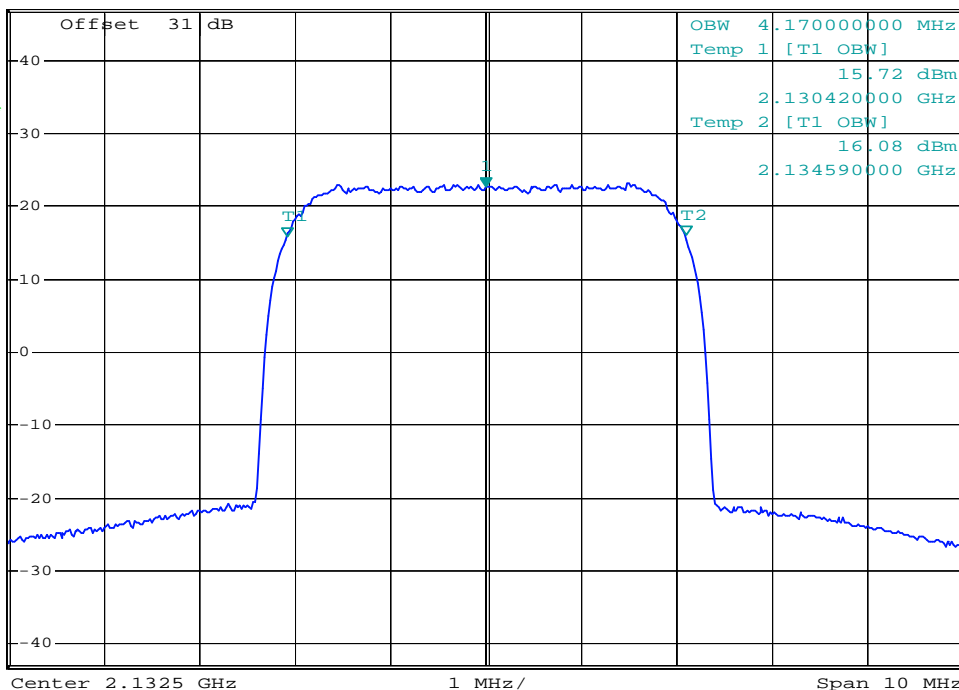

plot 6.3.1.2-#1 Occupied Bandwidth: §2.1049; RSS-GEN; Test results; Downlink; W-CDMA Output



OccupBW\_17P\_WCDMA  
04.Apr 11 13:15

\*RBW 30 kHz    Marker 1 [T1 ]  
\*VBW 300 kHz    -19.83 dBm  
\*SWT 9 s    2.13250000 GHz

Ref 10 dBm    Att 10 dB

1 RM\*  
CLRWR

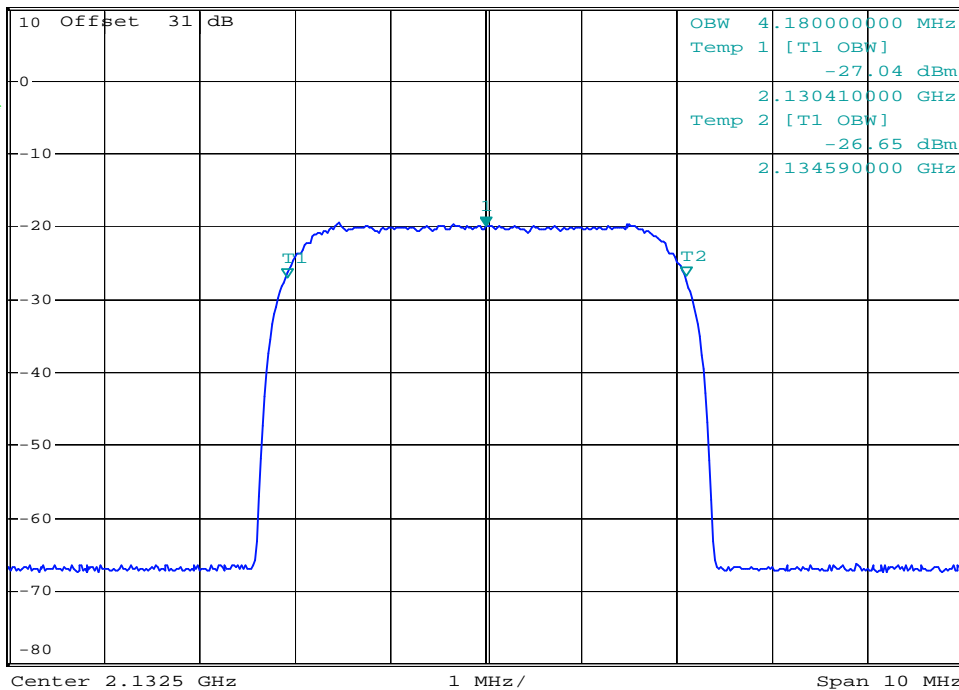

plot 6.3.1.2-#2 Occupied Bandwidth: §2.1049; RSS-GEN; Test results; Downlink; W-CDMA Input





FCC ID: XS5-ML717P

6.3.1.3 LTE

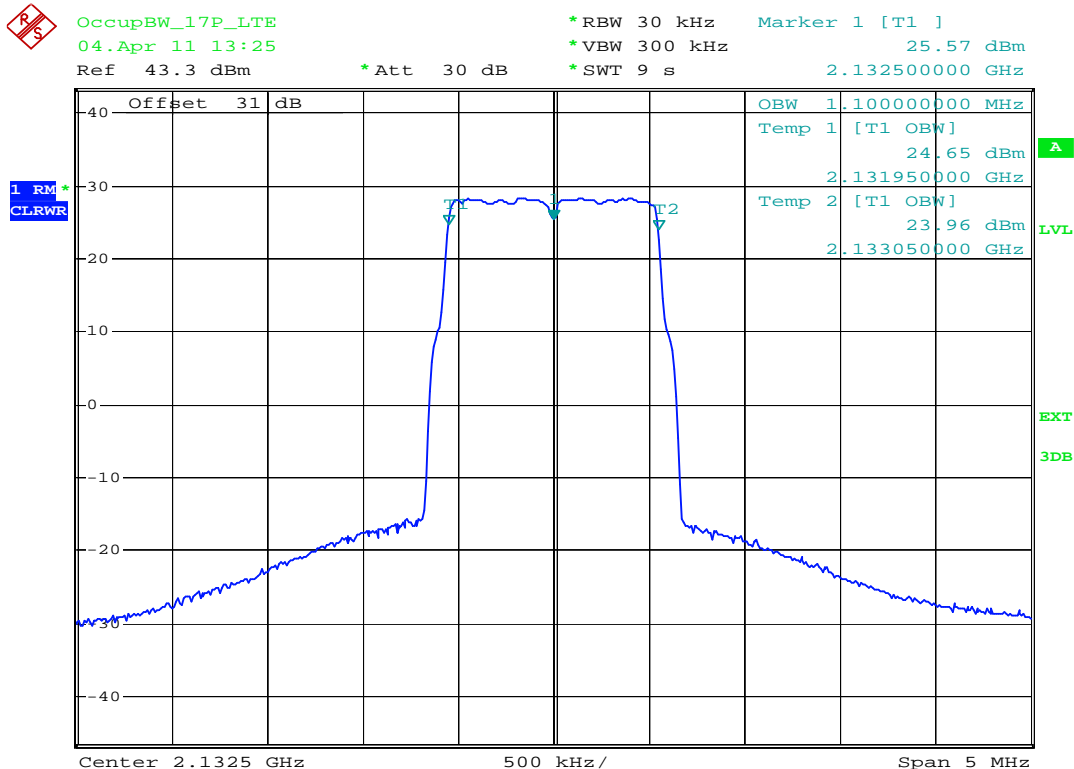

plot 6.3.1.3-#1 Occupied Bandwidth: §2.1049; RSS-GEN; Test results; Downlink; LTE Output

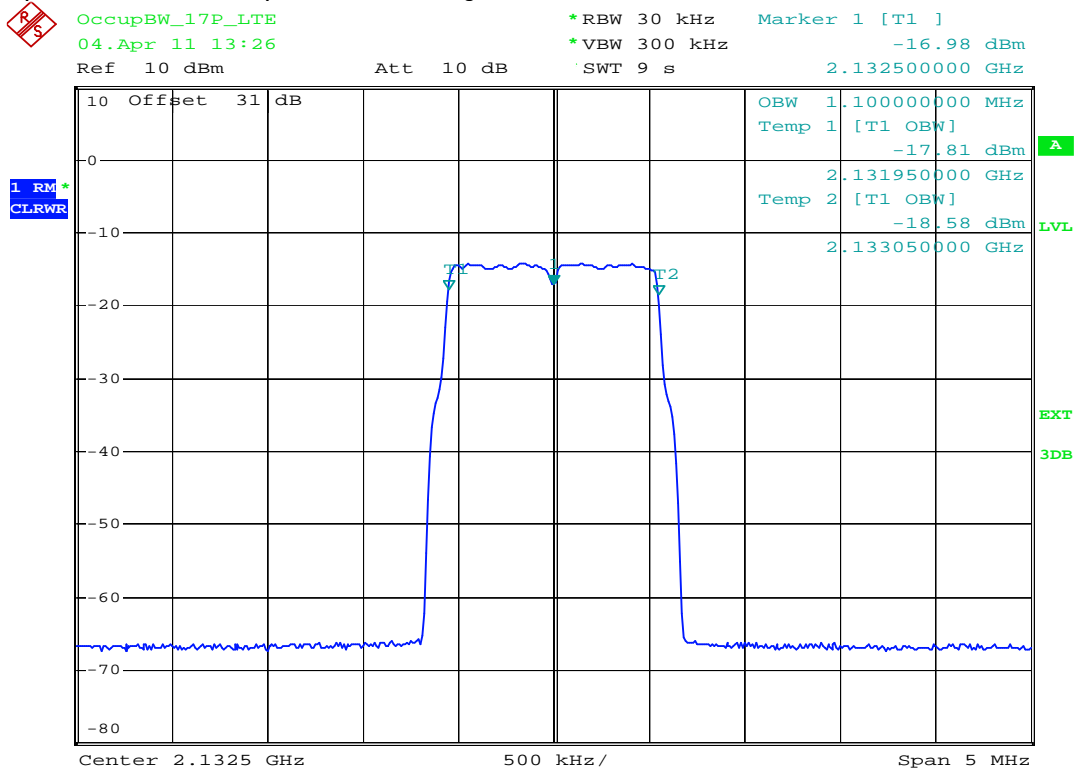

plot 6.3.1.3-#2 Occupied Bandwidth: §2.1049; RSS-GEN; Test results; Downlink; LTE Input



FCC ID: XS5-ML717P

---

### 6.3.2 Uplink

n.a.

Note: The EUT does not transmit over the air in the uplink direction.

### 6.4 Summary test result

Test result	complies, according the plots above
Tested by:	L.Oskerko
Date:	04.04.2011

## 7 Spurious Emissions at Antenna Terminals: §27.53, §2.1051; RSS-139, RSS-GEN

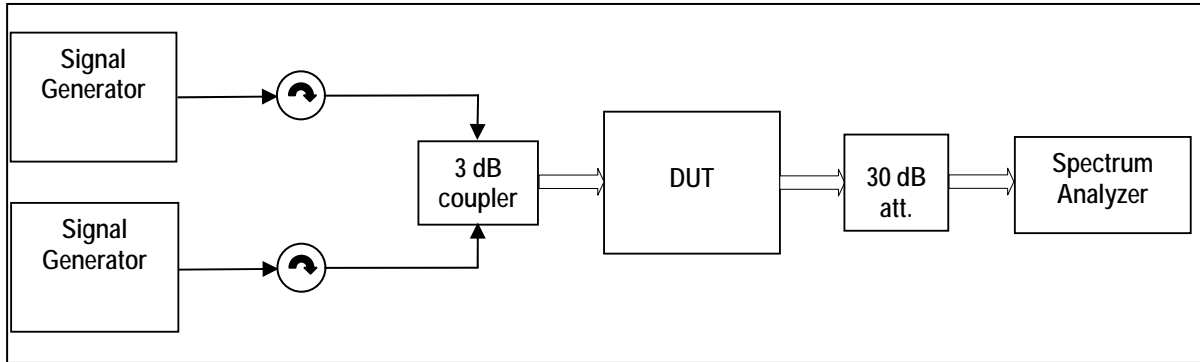

figure 7-#1 Test setup: Spurious Emissions at Antenna Terminals: §27.53, §2.1051; RSS-139, RSS-GEN

Measurement uncertainty	± 0,54 dB ± 1,2 dB ± 1,5 dB	9 kHz to 3 GHz 3 GHz to 7 GHz 7 GHz to 26 GHz
Test equipment used	8890; 8667; 8668; 8848; 7355;	

### 7.1 Limit

Minimum standard:

Para. No.27.53(h)

(h) For operations in the 1710–1755 MHz and 2110–2155 MHz bands, the power of any emission outside a licensee’s frequency block shall be attenuated below the transmitter power (P) by at least  $43 + 10 \log_{10}(P)$  dB.

(1) Compliance with this provision is based on the use of measurement instrumentation employing a resolution bandwidth of 1 megahertz or greater. However, in the 1 megahertz bands immediately outside and adjacent to the licensee’s frequency block, a resolution bandwidth of at least one percent of the emission bandwidth of the fundamental emission of the transmitter may be employed. The emission bandwidth is defined as the width of the signal between two points, one below the carrier center frequency and one above the carrier center frequency, outside of which all emissions are attenuated at least 26 dB below the transmitter power.

(2) When measuring the emission limits, the nominal carrier frequency shall be adjusted as close to the licensee’s frequency block edges, both upper and lower, as the design permits.

(3) The measurements of emission power can be expressed in peak or average values, provided they are expressed in the same parameters as the transmitter power.

### 7.2 Test method

Para. No 2.1051 Measurements required: Spurious emissions at antenna terminals.

The radio frequency voltage or powers generated within the equipment and appearing on a spurious frequency shall be checked at the equipment output terminals when properly loaded with a suitable artificial antenna. Curves or equivalent data shall show the magnitude of each harmonic and other spurious emission that can be detected when the equipment is operated under the conditions specified in § 2.1049 as appropriate. The magnitude of spurious emissions which are attenuated more than 20 dB below the permissible value need not be specified.

[39 FR 5919, Feb. 15, 1974. Redesignated and amended at 63 FR 36599, July 7, 1998]



FCC ID: XS5-ML717P

### 7.3 Test results

#### 7.3.1 Downlink

<1MHz from Band Edge

Detector: RMS.

Modulation	Measured at Band Edge	Carriers	RBW VBW Span	Max. level (dBm)	Plot -
WCDMA	Lower Edge Upper Edge	2110,775 MHz 2112,025 MHz 2152,975 MHz 2154,225 MHz	30kHz 300kHz 6MHz	-19,86	7.3.1.1 #1 #2
CDMA	Lower Edge Upper Edge	2112,6 MHz 2117,6 MHz 2147,4 MHz 2152,4 MHz	100kHz 1MHz 15MHz	-24,44	7.3.1.2 #1 #2
LTE	Lower Edge Upper Edge	2110,7 MHz 2112,1 MHz 2152,9 MHz 2154,3 MHz	30kHz 300kHz 6MHz	-18,47	7.3.1.3 #1 #2

table 7.3-#1 Spurious Emissions at Antenna Terminals: §27.53, §2.1051; RSS-139, RSS-GEN Test results Downlink <1MHz from Band Edge

>1MHz from Band Edge

Detector: RMS.

Modulation	Carrier at	Carrier	Max. level (dBm)	RBW VBW Frequency range	Plot -
CDMA	Middle	2132,5 MHz	< -30	1MHz 3MHz 30MHz – 22GHz	7.3.1.4 #1
WCDMA	Middle	2132,5 MHz	< -30	1MHz 3MHz 30MHz – 22GHz	7.3.1.5 #1
LTE	Middle	2132,5 MHz	< -30	1MHz 3MHz 30MHz – 22GHz	7.3.1.6 #1

table 7.3-#2 Spurious Emissions at Antenna Terminals: §27.53, §2.1051; RSS-139, RSS-GEN Test results Downlink >1MHz from Band Edge



FCC ID: XS5-ML717P

7.3.1.1 WCDMA < 1MHz to band edge

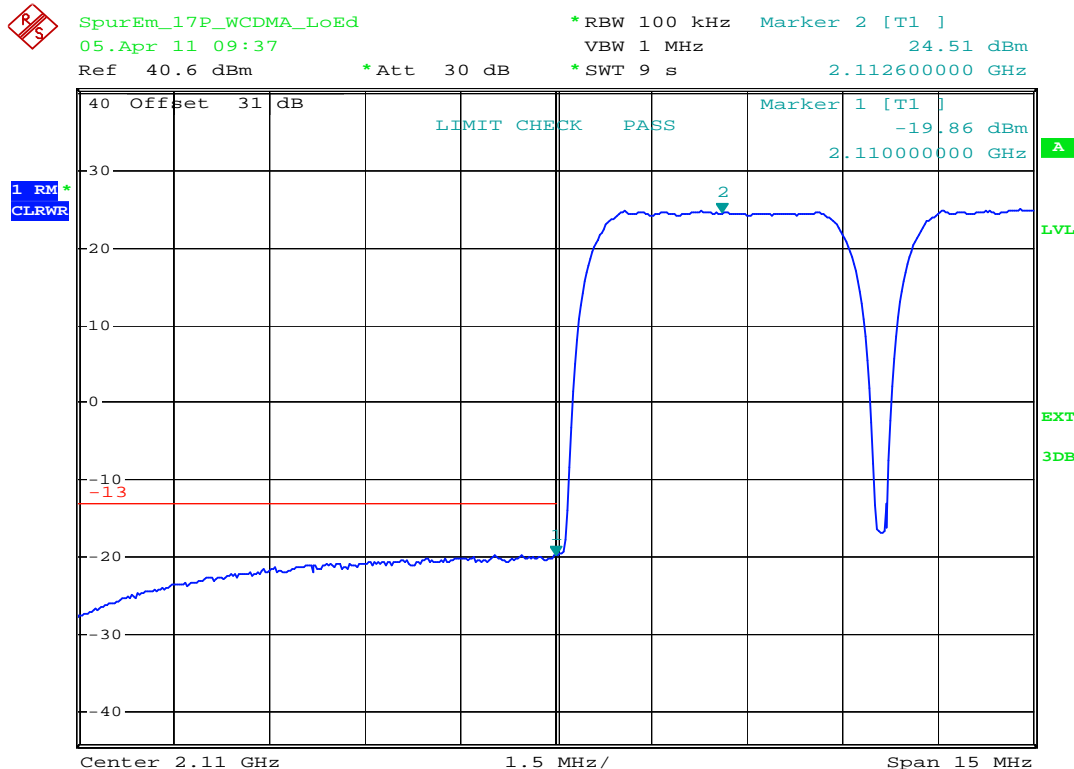

plot 7.3.1.1-#1 Spurious Emissions at Antenna Terminals: §27.53, §2.1051; RSS-139, RSS-GEN; Test results; Downlink; WCDMA < 1MHz to band edge Lower Band Edge

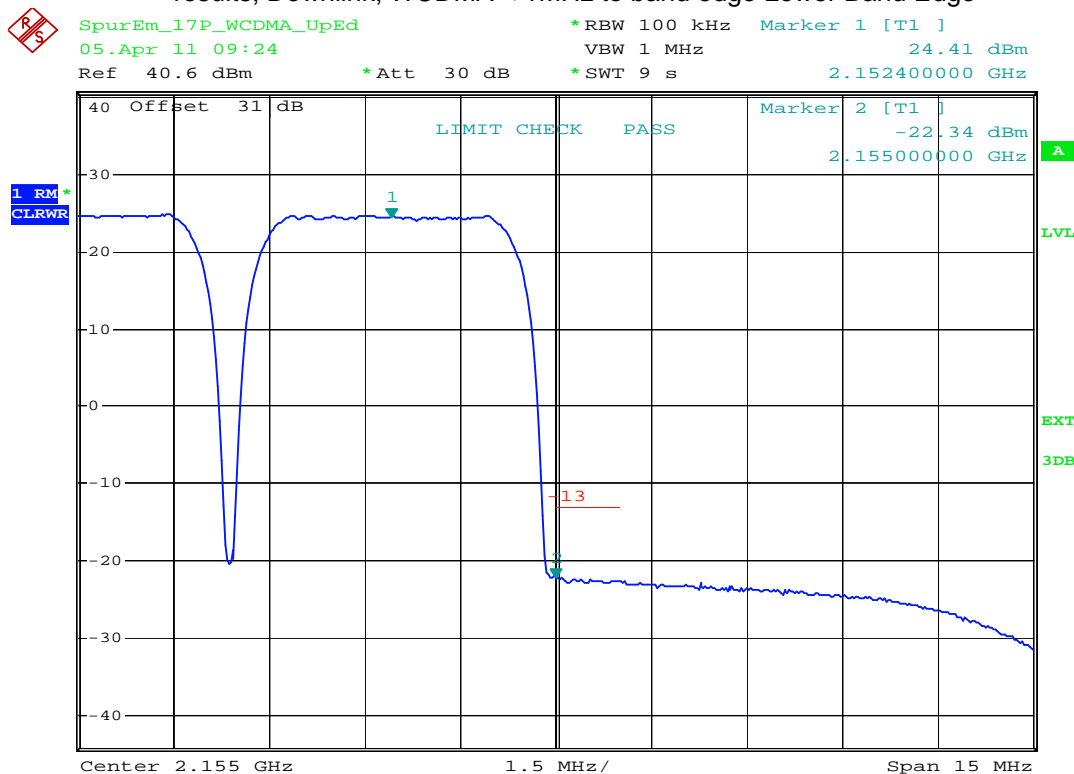

plot 7.3.1.1-#2 Spurious Emissions at Antenna Terminals: §27.53, §2.1051; RSS-139, RSS-GEN; Test results; Downlink; WCDMA < 1MHz to band edge Upper Band Edge



FCC ID: XS5-ML717P

### 7.3.1.2 CDMA < 1MHz to band edge

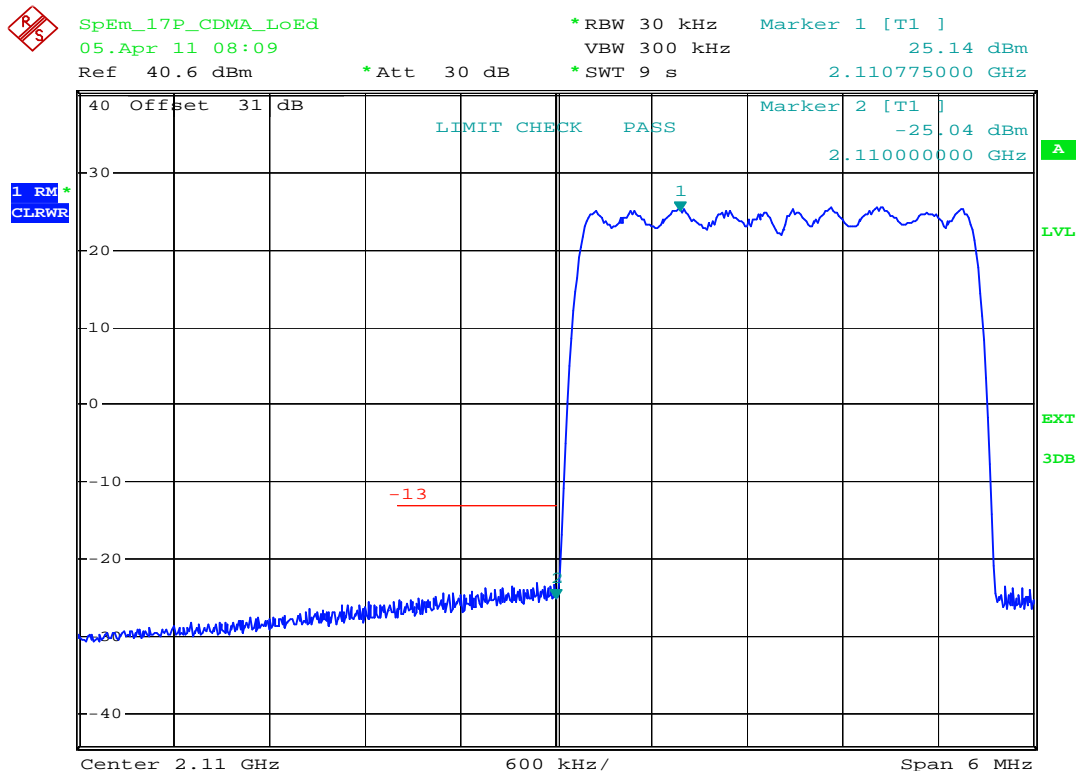

plot 7.3.1.2-#1 Spurious Emissions at Antenna Terminals: §27.53, §2.1051; RSS-139, RSS-GEN; Test results; Downlink; CDMA < 1MHz to band edge Lower Band Edge

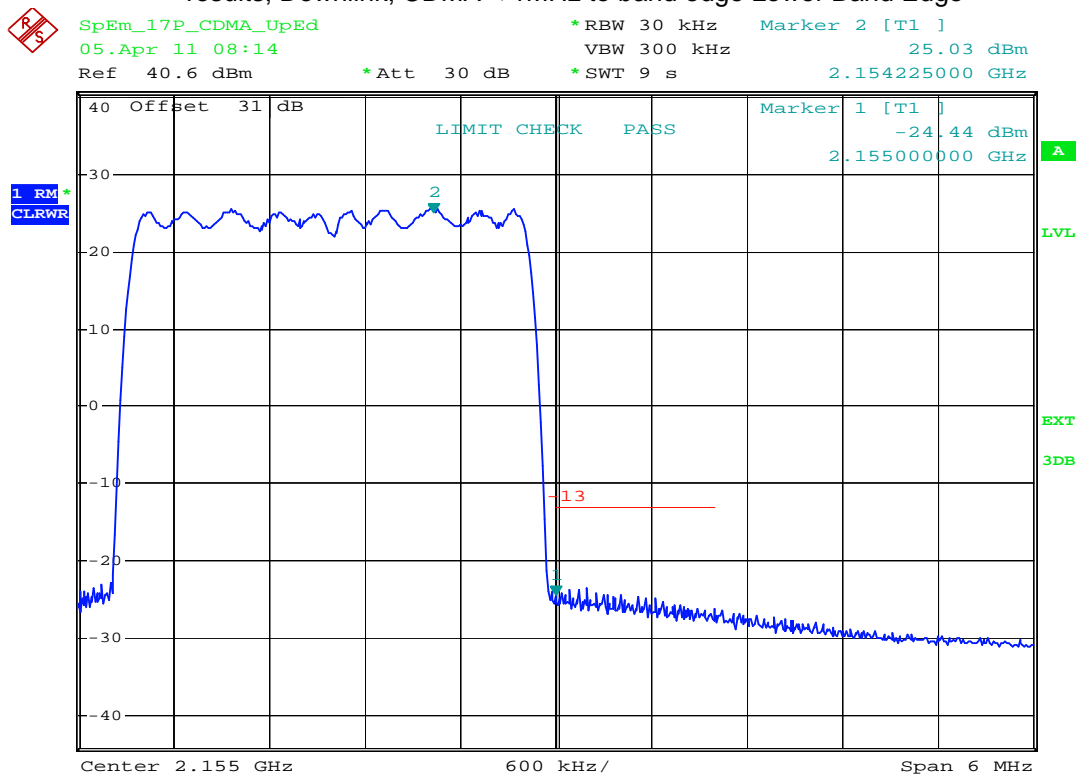

plot 7.3.1.2-#2 Spurious Emissions at Antenna Terminals: §27.53, §2.1051; RSS-139, RSS-GEN; Test results; Downlink; CDMA < 1MHz to band edge Upper Band Edge



FCC ID: XS5-ML717P

7.3.1.3 LTE < 1MHz to band edge

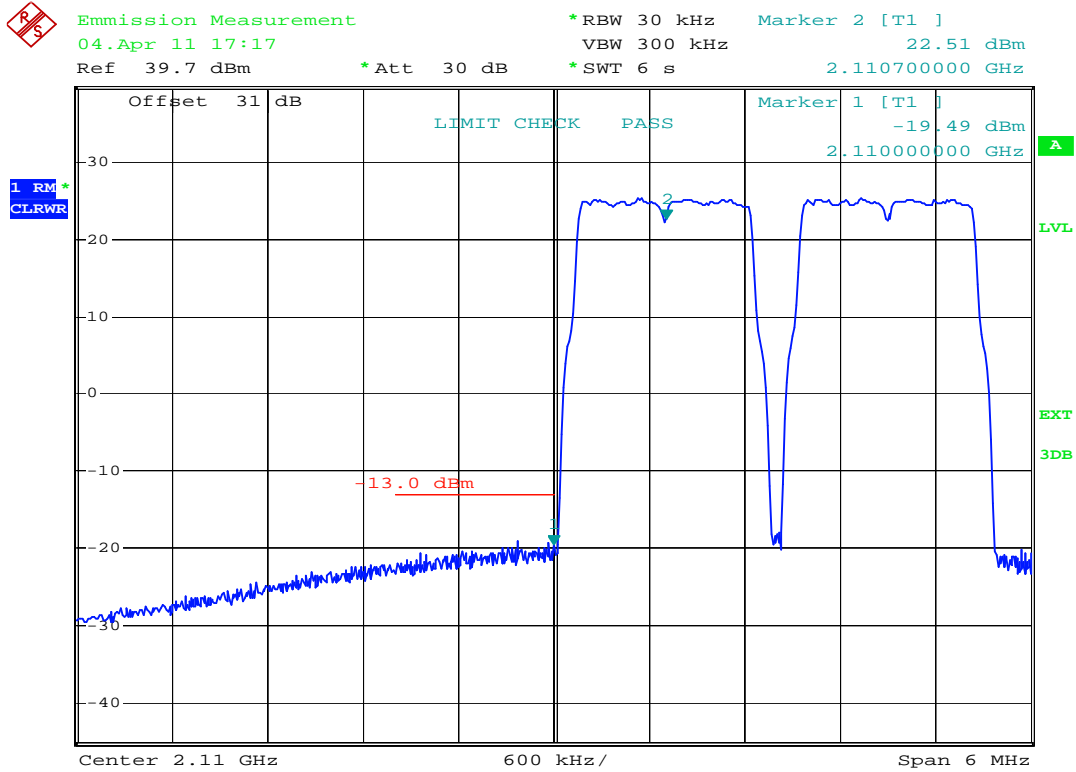

plot 7.3.1.3-#1 Spurious Emissions at Antenna Terminals: §27.53, §2.1051; RSS-139, RSS-GEN; Test results; Downlink; LTE < 1MHz to band edge Lower Band Edge

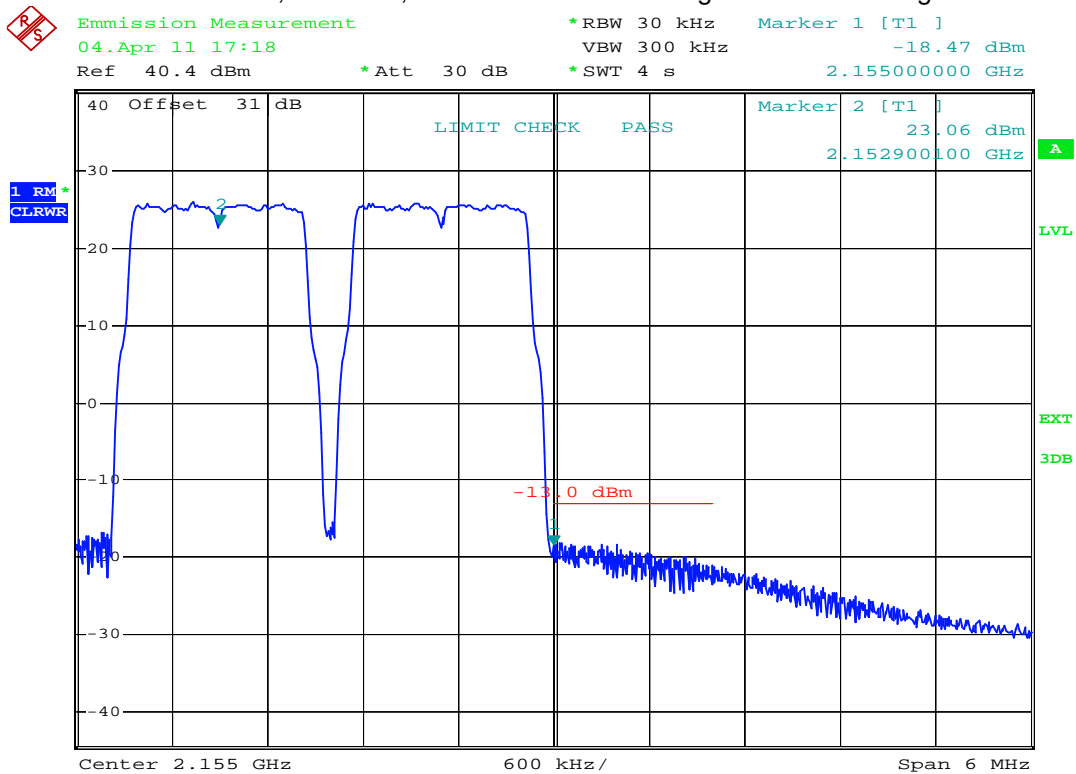

plot 7.3.1.3-#2 Spurious Emissions at Antenna Terminals: §27.53, §2.1051; RSS-139, RSS-GEN; Test results; Downlink; LTE < 1MHz to band edge Upper Band Edge



FCC ID: XS5-ML717P

### 7.3.1.4 CDMA > 1MHz to band edge

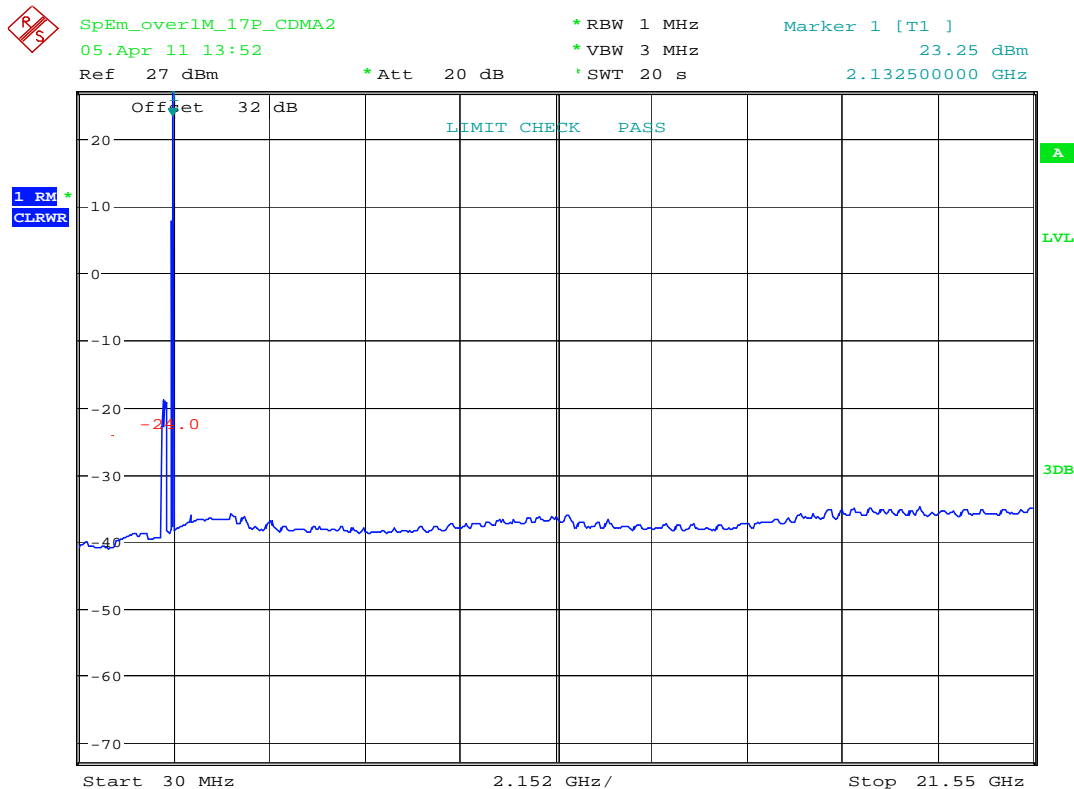

plot 7.3.1.4-#1 Spurious Emissions at Antenna Terminals: §27.53, §2.1051; RSS-139, RSS-GEN; Test results; Downlink; CDMA > 1MHz to band edge; carrier (2132,5MHz) notched

### 7.3.1.5 W-CDMA > 1MHz to band edge

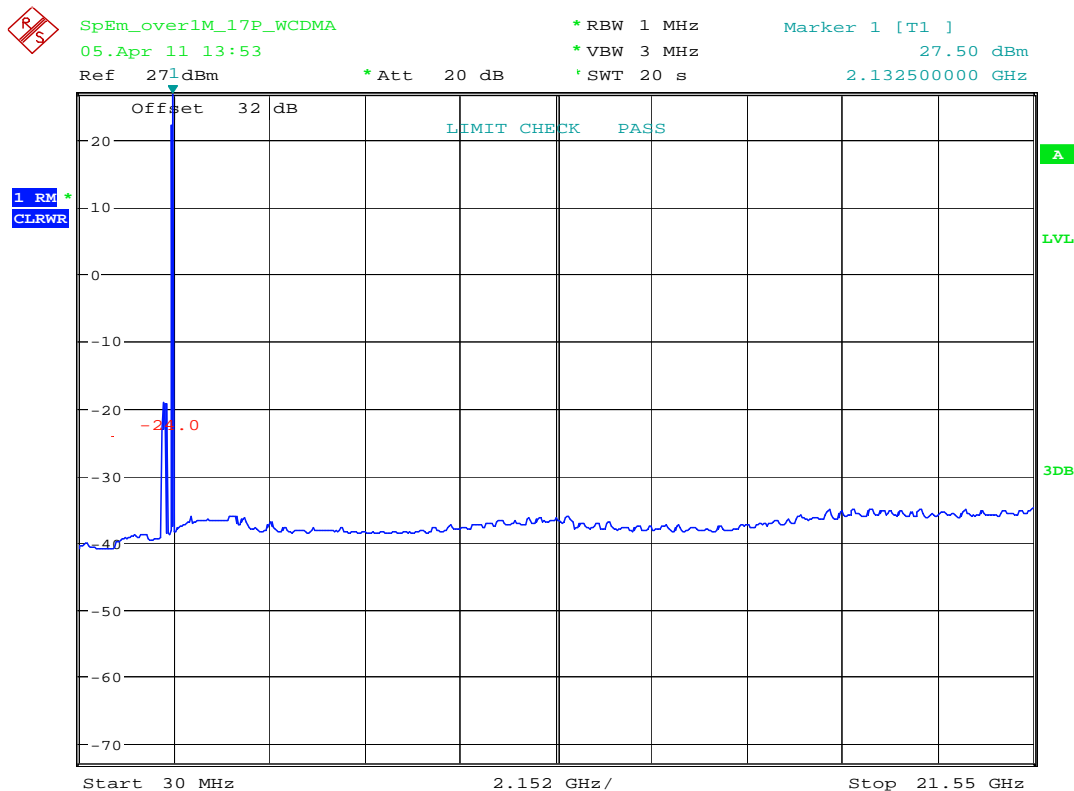

plot 7.3.1.5-#1 Spurious Emissions at Antenna Terminals: §27.53, §2.1051; RSS-139, RSS-GEN; Test results; Downlink; W-CDMA > 1MHz to band edge; carrier (2132,5MHz) notched





FCC ID: XS5-ML717P

7.3.1.6 LTE > 1MHz to band edge

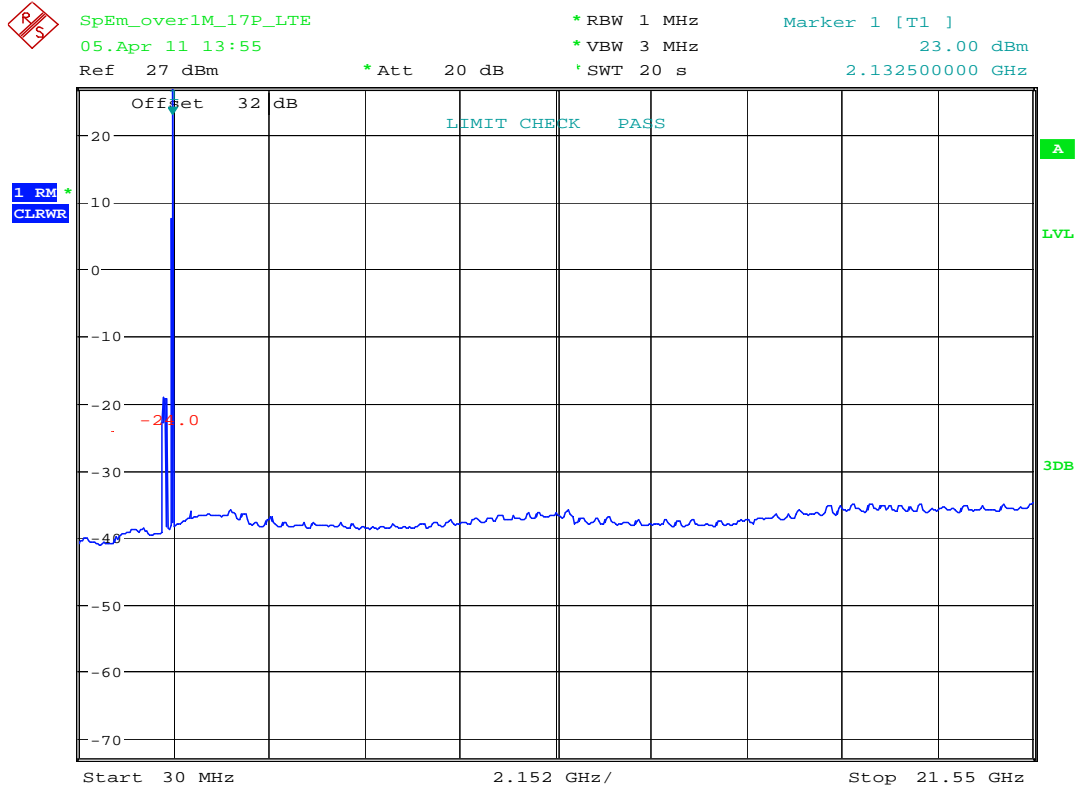

plot 7.3.1.6-#1 Spurious Emissions at Antenna Terminals: §27.53, §2.1051; RSS-139, RSS-GEN; Test results; Downlink; LTE > 1MHz to band edge; carrier (2132,5MHz) notched

7.3.2 Uplink

n.a.

Note: The EUT does not transmit over the air in the uplink direction.

7.4 Summary test result

Test result	complies, according to the plots above
Tested by:	L.Oskerko
Date:	05.04.2011

## 8 Field Strength of Spurious Emissions: §27.53, §2.1053, RSS-139



picture 8.1: label



picture 8.2: Test setup: Field Strength Emission <1 GHz @3m in the FAC

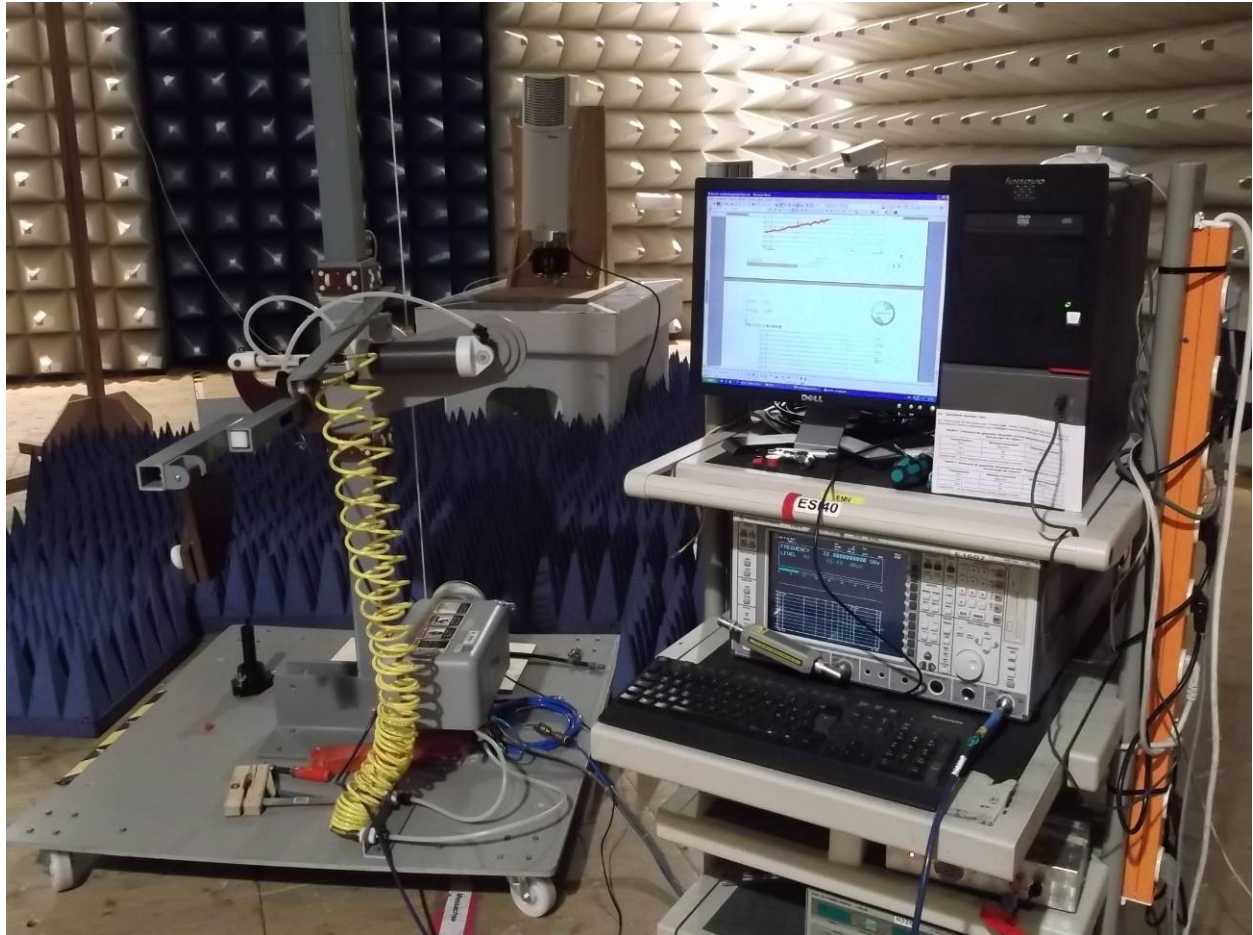

**picture 8.3:** Test setup: Field Strength Emission >1 GHz @3m in the FAC



**FCC ID: XS5-ML717P**

This clause specifies requirements for the measurement of radiated emission.

Frequency range	Distance: EUT <-> antenna / location	Limit	Test method
30 MHz - 1 GHz	3 metres / FAC	FCC 47 CFR Part 27.53	TIA/EIA-603-C:2004
		IC RSS-139 sec. 6.4	
1 GHz – 22 GHz		FCC 47 CFR Part 27.53	
		IC RSS-139 sec. 6.4	

**Test equipment used:**

Designation	Type	Manufacturer	Invent.-no.	Cal.-date	due Cal.- date	used
EMI test receiver	ESI40	Rohde & Schwarz	E1687	23.05.2011	23.05.2012	X
Antenna	CBL 6111	Chase	K1149	30.05.2011	30.05.2012	X
RF Cable		Frankonia	K1121 SET	14.07.2011	14.07.2012	X
Antenna	HL 025	R&S	K809	25.07.2011	25.07.2012	X
Preamplifier	AFS4- 00102000	Miteq	K838	09.02.2011	09.02.2012	X
RF Cable	Sucoflex 100	Suhner	K1742	05.04.2011	05.04.2012	X

The REMI version 2.135 has been used for max search.

**Test set-up:**

Test location: FAC  
 The Fully Anechoic Chamber (FAC) fulfils the requirements of ANSI C63.4 and CISPR 16-1-4 with regards to NSA and SVSWR.

Test Voltage: 115V / 60 Hz  
 Type of EUT: Wall mounted

**Measurement uncertainty:**

Measurement uncertainty expanded (95% or K=2)	± 4,7 dB for ANSI C63.4 measurement ± 0,5 dB for TIA-603 measurement
--	---

## 8.1 Method of Measurement

### Measurement procedure. TIA-603-C

The antenna substitution method is used to determine the equivalent radiated power at spurious frequencies. The spurious emissions are measured at a distance of 3 meters. The EUT is then replaced with a reference substitution antenna with a known gain referenced to a dipole. This antenna is fed with a signal at the spurious frequency. The level of the signal is adjusted to repeat the previously measured level. The resulting eirp is the signal level fed to the reference antenna corrected for gain referenced to an isotropic dipole (see Figure 7.2).

From KDB (AMPLIFIER, BOOSTER, AND REPEATER REMINDER SHEET):

Radiated spurs (enclosure) – Use of CW signal (low, mid. and high freq.) is acceptable rather than all modulations.

The maximum RFI field strength was determined during the measurement by rotating the turntable ( $\pm 180$  degrees) and varying the height of the receive antenna ( $h = 1 \dots 4$  m) as like defined in ANSI C63.4. A measurement receiver has been used with a RBW 120 kHz up to 1 GHz and 1 MHz above 1 GHz. Steps with during pre measurement was half the RBW.

Both, the Fully Anechoic Chamber (FAC) and the Semi Anechoic Chamber (SAC) fulfil the requirements of ANSI C63.4 and CISPR 16-1-4 with regards to NSA and SVSWR.

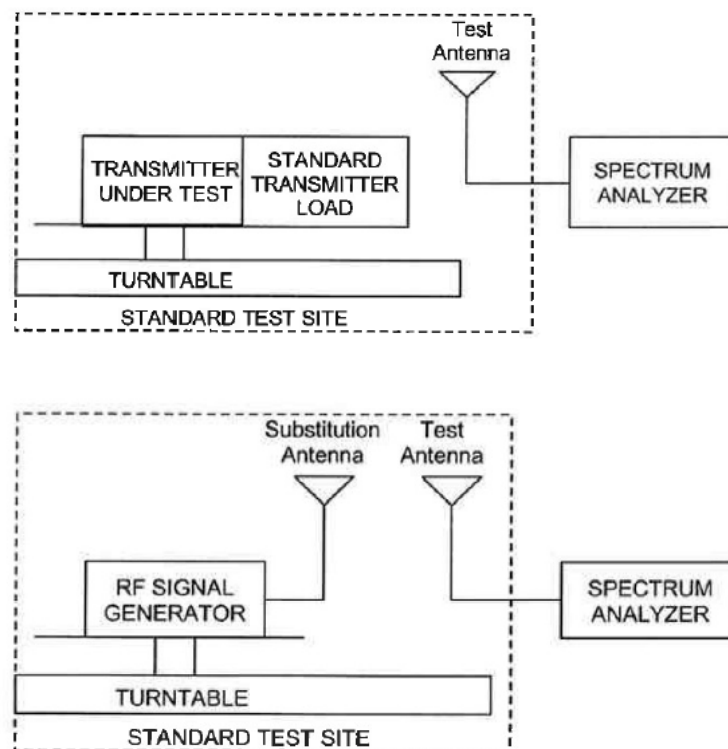

Figure #7.2 Substitution methods TIA/EIA-603-C





## 8.2 Limit §27.53 (h)

(h) For operations in the 1710–1755 MHz and 2110–2155 MHz bands, the power of any emission outside a licensee's frequency block shall be attenuated below the transmitter power (P) by at least  $43 + 10 \log_{10}(P)$  dB.

(1) Compliance with this provision is based on the use of measurement instrumentation employing a resolution bandwidth of 1 megahertz or greater. However, in the 1 megahertz bands immediately outside and adjacent to the licensee's frequency block, a resolution bandwidth of at least one percent of the emission bandwidth of the fundamental emission of the transmitter may be employed. The emission bandwidth is defined as the width of the signal between two points, one below the carrier center frequency and one above the carrier center frequency, outside of which all emissions are attenuated at least 26 dB below the transmitter power.

(2) When measuring the emission limits, the nominal carrier frequency shall be adjusted as close to the licensee's frequency block edges, both upper and lower, as the design permits.

(3) The measurements of emission power can be expressed in peak or average values, provided they are expressed in the same parameters as the transmitter power.

The Emission limit is -13dBm.

## 8.3 Climatic values in the lab

Temperature:	21°
Relative Humidity:	45%
Air-pressure:	1004 hPa



## 8.4 Test results

### 8.4.1 30 MHz to 1 GHz Downlink (Bottom – Middle – Top)

B/M/T: 2110 MHz / 2132,5 MHz / 2155 MHz (Operation with maximum composite power)

Horizontal / **Vertikal**

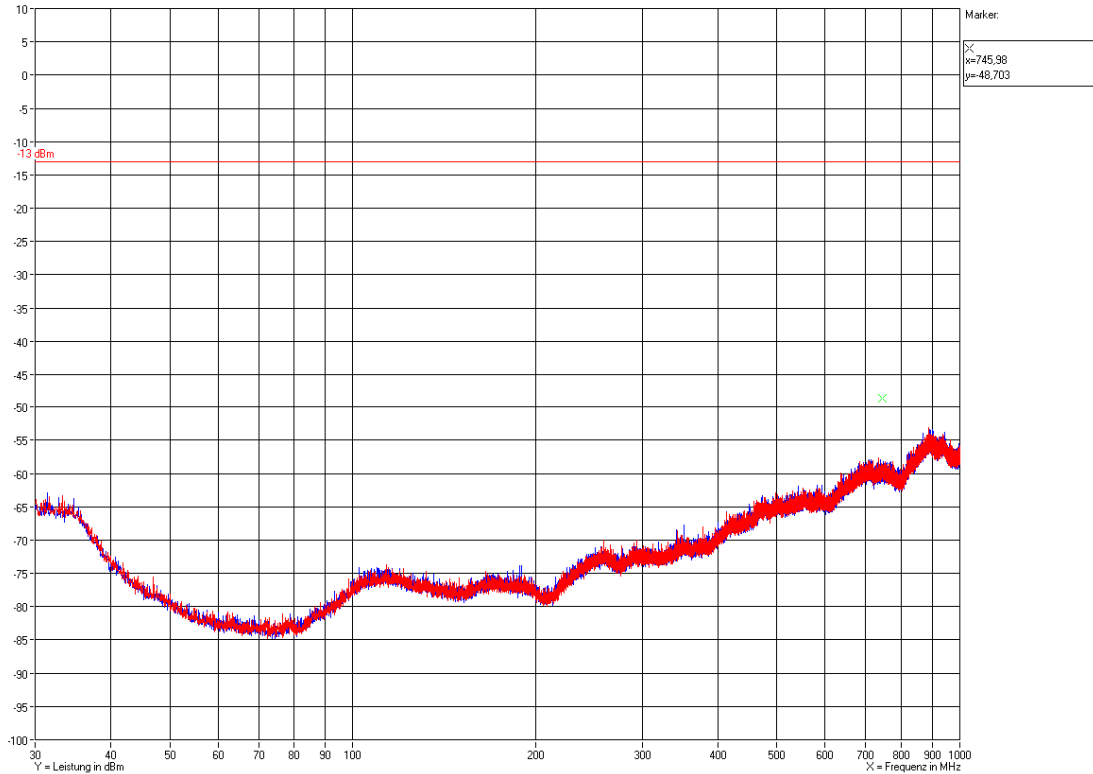

Measurement with Peak detector, BW 120KHz,  
Step width 60 kHz, dwell time 50ms

Antenna height: 1.55m; all positions of the turn  
table measured with max. hold function

Polarization: Horizontal / **Vertikal**

No peak detected 20dB above noise



FCC ID: XS5-ML717P

### 8.4.2 30 MHz to 1 GHz Downlink (middle of all carrier)

B/M/T: 2110 MHz / 2132,5 MHz / 2155 MHz (Operation with maximum composite power)

Horizontal / Vertical

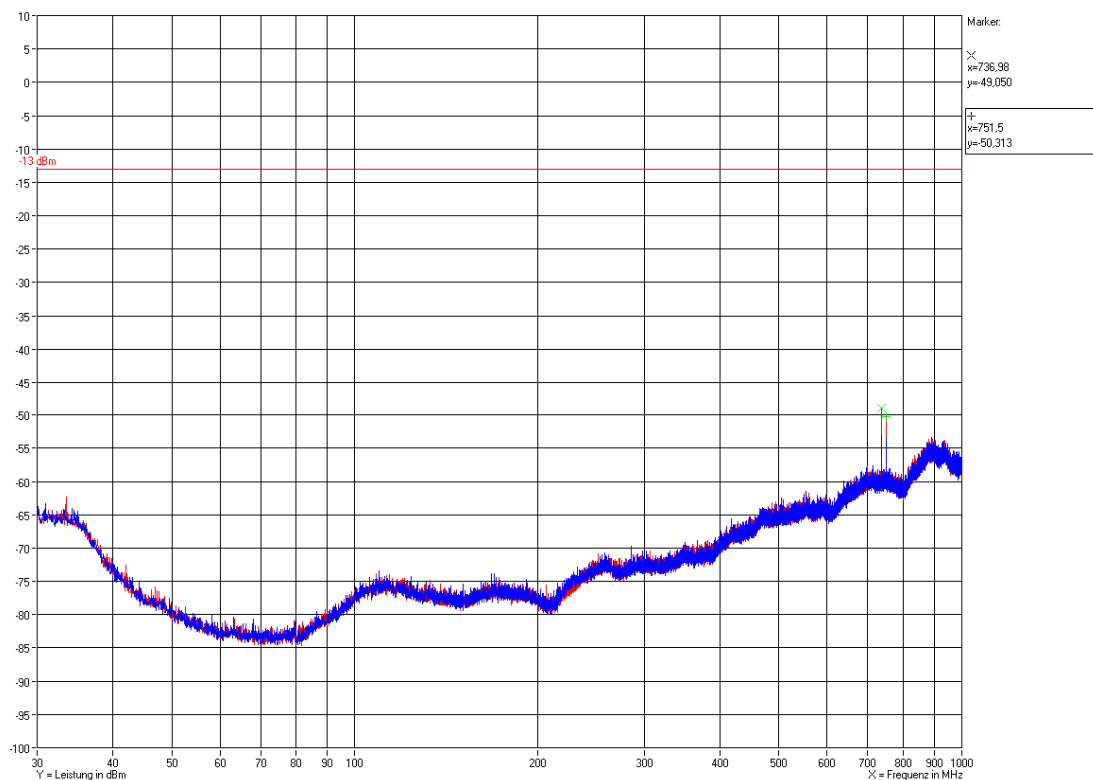





FCC ID: XS5-ML717P

### 8.4.3 1 GHz to 22 GHz Downlink (Bottom – Middle – Top)

B/M/T: 2110 MHz / 2132,5 MHz / 2155 MHz (Operation with maximum composite power)

Horizontal / Vertikal

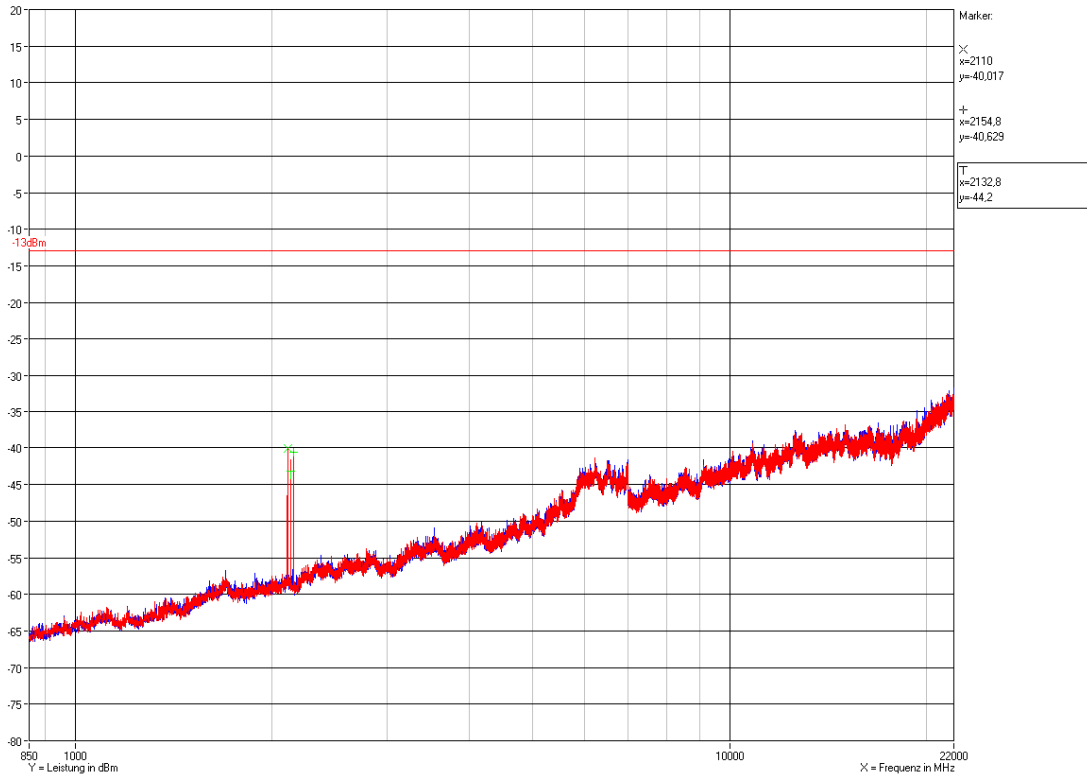



**8.4.4 1 GHz to 22 GHz Downlink (middle of all carrier)**

B/M/T: 737 MHz / 751.5 MHz / 2132.5 MHz (Operation with maximum composite power)

Horizontal / Vertical

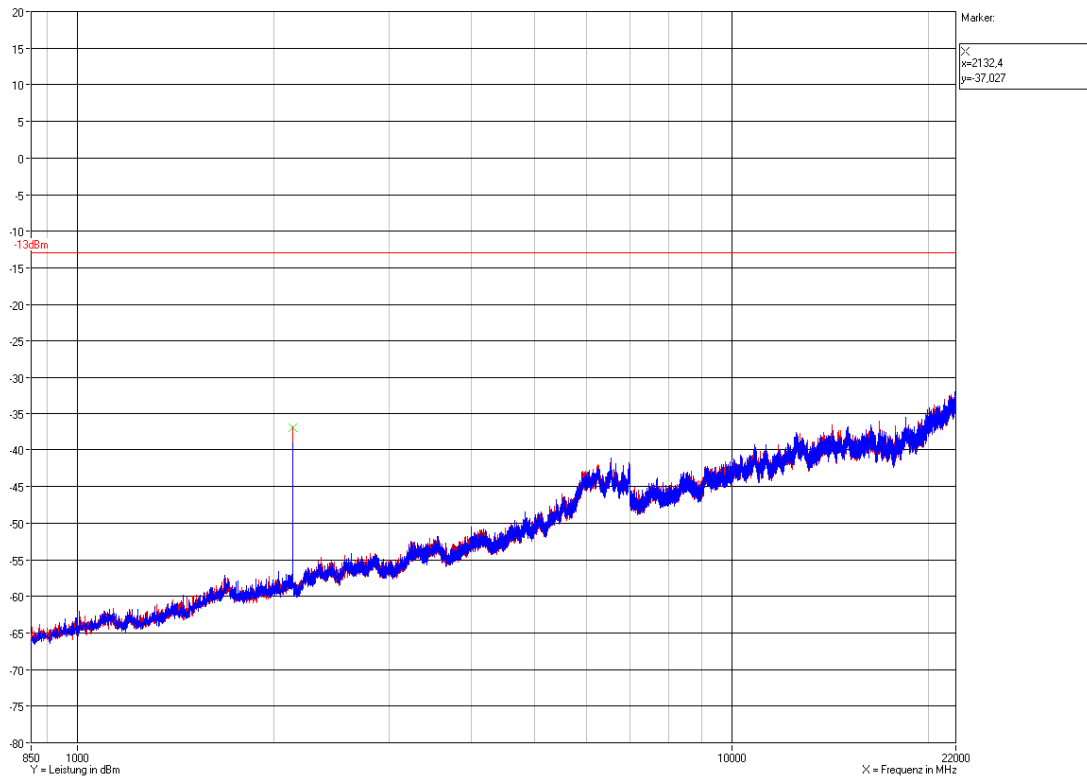

Zahlmann / 24.01.2012

**The radiated spurious emission requirements have been met in all frequency bands.**

**9 History**

Revision	Modification	Date	Name
01.00	Initial Test report	26.01.2012	T. Zahlmann



**\*\*\*\*\* End of test report \*\*\*\*\***