

Test Site:  
FCC Test Site No.:  
IC OATS No.:

96997  
IC3475A-1



**BUREAU  
VERITAS**

## ECL-EMC Test Report No.: 12-227

**Equipment under test:** ION-M85P R EP  
**FCC ID:** XS5-M85PR  
**IC ID:** 2237E-M85PR  
**Type of test:** **FCC 47 CFR Part 22 Subpart H:2012**  
Cellular Radiotelephone Service  
**IC RSS-131:2003**  
Zone Enhancers for the Land Mobile Service

**Measurement Procedures:** 47 CFR Parts 2: 2012 (*Frequency Allocations and Radio Treaty Matters; General Rules and Regulations*), Part 22: 2012 (*Cellular Radiotelephone Service*), ANSI/TIA-603-C (2004), *Land Mobile FM or PM Communications Equipment Measurement and Performance Standards*  
IC RSS-GEN: 2010 General Requirements and Information for the Certification of Radiocommunication Equipment

**Test result:** **Passed**

Date of issue:	04.12.12		Signature:
Issue-No.:	01	Author:	
Date of delivery:	27.11.12	Checked:	
Test dates:	25.10. – 27.12.12		
Pages:	46		

Test Report No.: 12-227

FCC ID: XS5-M85PR

IC ID: 2237E- M85PR



BUREAU  
VERITAS

**Manufacturer:** ANDREW Wireless Systems GmbH  
Industriering 10

D-86675 Buchdorf

Tel.: +49 (0)9099 69 0

Fax: +49 (0)9099 69 140

**Test Location:** Bureau Veritas Consumer Products Services  
Germany GmbH  
European Compliance Laboratory (ECL)  
Thurn-und-Taxis-Straße 18

D-90411 Nürnberg

Tel.: +49 40 74041 0

Fax: +49 40 74041-2755

**General:**

The purpose of this report is to show compliance to the FCC regulations for licensed devices operating under section 22 of the Code of Federal Regulations title 47.

This report informs about the results of the RF tests, it only refers to the equipment under test. No part of this report may be reproduced in any form, without written permission.



## Table of contents

1	TEST RESULTS SUMMARY .....	6
2	EQUIPMENT UNDER TEST (E.U.T.) .....	7
2.1	DESCRIPTION .....	7
2.1.1	DOWNLINK .....	7
2.1.2	UPLINK .....	7
2.1.3	DESCRIPTION OF EUT .....	8
2.1.4	BLOCK DIAGRAM OF MEASUREMENT REFERENCE POINTS .....	8
2.1.5	DOWNLINK SYSTEM GAIN AND OUTPUT POWER.....	9
3	TEST SITE (ANDREW BUCHDORF) .....	9
3.1	TEST ENVIRONMENT .....	9
3.2	TEST EQUIPMENT .....	10
3.3	INPUT AND OUTPUT LOSSES .....	10
3.4	MEASUREMENT UNCERTAINTY .....	10
4	TEST SITE (BUREAU VERITAS) .....	11
5	RF POWER OUT: §22.913, §2.1046; IC RSS-131 .....	12
5.1	LIMIT.....	12
5.2	TEST METHOD .....	12
5.3	TEST RESULTS.....	13
5.3.1	DOWNLINK.....	14
5.3.1.1	CDMA .....	15
5.3.1.2	WCDMA.....	15
5.3.1.3	LTE .....	16
5.3.2	UPLINK .....	16
5.4	SUMMARY TEST RESULT.....	16
6	OCCUPIED BANDWIDTH: §2.1049; RSS-GEN.....	17
6.1	LIMIT.....	17
6.2	TEST METHOD .....	17
6.3	TEST RESULTS .....	17
6.3.1	DOWNLINK.....	18
6.3.1.1	CDMA .....	19
6.3.1.2	WCDMA.....	20
6.3.1.3	LTE .....	21
6.3.2	UPLINK .....	22
6.4	SUMMARY TEST RESULT.....	22
7	SPURIOUS EMISSIONS AT ANTENNA TERMINALS: §22.917, §2.1051; RSS-131, RSS-GEN .....	23
7.1	LIMIT.....	23
7.2	TEST METHOD .....	23
7.3	TEST RESULTS .....	24



7.3.1	DOWNLINK .....	24
7.3.1.1	CDMA < 1MHz to band edge.....	25
7.3.1.2	WCDMA < 1MHz to band edge .....	26
7.3.1.3	LTE < 1MHz to band edge.....	27
7.3.1.4	CDMA > 1MHz to band edge.....	28
7.3.1.5	WCDMA > 1MHz to band edge .....	28
7.3.1.6	LTE > 1MHz to band edge.....	29
7.3.2	UPLINK .....	29
7.4	SUMMARY TEST RESULT .....	29
8	AMPLIFIER GAIN AND BANDWIDTH: IC RSS-131 .....	30
8.1	LIMIT.....	30
8.2	TEST METHOD .....	30
8.3	TEST RESULTS .....	30
8.3.1	DOWNLINK .....	30
8.3.2	UPLINK .....	31
8.4	SUMMARY TEST RESULT .....	31
9	OUTPUT POWER: IC RSS-131 .....	32
9.1	LIMIT.....	32
9.2	TEST METHOD .....	32
9.3	TEST RESULTS .....	33
9.3.1	DOWNLINK .....	33
9.3.2	UPLINK .....	33
9.4	SUMMARY TEST RESULT .....	33
10	NON-LINEARITY: IC RSS-131 .....	34
10.1	LIMIT .....	34
10.2	TEST METHOD.....	34
10.3	TEST RESULTS.....	35
10.3.1	DOWNLINK .....	35
10.3.2	UPLINK .....	35
10.4	SUMMARY TEST RESULT .....	35
11	SPURIOUS EMISSIONS: RSS-131 .....	36
11.1	LIMIT .....	36
11.2	TEST METHOD.....	36
11.3	TEST RESULTS.....	36
11.3.1	DOWNLINK .....	36
11.3.2	UPLINK .....	38
11.4	SUMMARY TEST RESULT .....	38
12	FIELD STRENGTH OF SPURIOUS EMISSIONS: §22.917, §2.1053.....	39
12.1	LIMIT §22.917 .....	42
12.2	TEST METHOD ANSI/TIA/EA-603-C.....	43
12.3	CLIMATIC VALUES IN THE LAB .....	43

Test Report No.: 12-227

FCC ID: XS5-M85PR

IC ID: 2237E- M85PR



**BUREAU**  
**VERITAS**

---

12.4	TEST RESULTS.....	44
12.4.1	30 MHz TO 1 GHz DOWNLINK (BOTTOM – MIDDLE – TOP).....	44
12.4.2	1 GHz TO 18 GHz DOWNLINK .....	45
12.5	SUMMARY TEST RESULT .....	46
13	HISTORY .....	46



# 1 Test Results Summary

Name of Test	FCC Para. No.	FCC Method	FCC Spec.	Result
RF Power Output	22.913	2.1046	500 Watts	Complies
Occupied Bandwidth		2.1049	Input/Output	Complies
Spurious Emissions at Antenna Terminals	22.917	2.1051	-13dBm	Complies
Field Strength of Spurious Emissions	22.917	2.1053	-13dBm E.I.R.P	Complies
Frequency Stability	n.a.	2.1055	Must stay in band	NA

Name of Test	IC Para. No.	IC Method	Result
RF Power Output	RSS-131	RSS-GEN 4.8	Complies
Occupied Bandwidth	RSS-131	RSS-GEN 4.6.1	Complies
Spurious Emissions at Antenna Terminals	RSS-131	RSS-GEN 4.9	Complies
Field Strength of Spurious Emissions	RSS-131 6.4	RSS-GEN 4.9	Complies
Frequency Stability	RSS-131	RSS-GEN 4.7	NA

Frequency stability is given by: The system gets an electrical analog signal from the BSS which is converted into an analog optical signal, transmitted by the optical links and then reconverted in the Remote Unit into an analog electrical signal. During this process happens no frequency change/modification, so input and output have same frequency what can be seen under clause "Occupied Bandwidth".



## 2 Equipment under test (E.U.T.)

### 2.1 Description

Kind of equipment	ION-M85P R EP
Andrew Ident. Number	Id. No. 7659140-0001
Serial no.(SN)	11
Revision	00
Software version and ID	n. a.
Type of modulation and Designator	CDMA (F9W) <input checked="" type="checkbox"/> W-CDMA (F9W) <input checked="" type="checkbox"/> LTE (G7D) <input checked="" type="checkbox"/>
Frequency Translation	F1-F1 <input checked="" type="checkbox"/> F1-F2 <input type="checkbox"/> N/A <input type="checkbox"/>
Band Selection	Software <input type="checkbox"/> Duplexer <input checked="" type="checkbox"/> Full band <input type="checkbox"/>

#### 2.1.1 Downlink

Pass band	Path 870 MHz – 882.5 MHz
Nominal 20dB bandwidth	15.9 MHz
Max. composite output power based on one carrier per path (rated)	42.5 dBm = 17.8 W
System Gain*	9.5 dB @ Pout BTS of 33 dBm

\*see 2.1.5

#### 2.1.2 Uplink

Pass band	Path 825 MHz – 837.5 MHz
Maximum rated output power	n. a.
System Gain*	n.a.

\*see 2.1.5

Note: The EUT does not transmit over the air in the uplink direction.



### 2.1.3 Description of EUT

The Remote Unit consists of the IONM85P R EP and the ION-M9P R EU. This system transports up to two frequency bands simultaneously (850 MHz and 900 MHz), providing a cost-effective solution for distributing capacity from one or more base stations with full PSU and PA redundancy for GoS (Grade of Service) sensitive networks.

The IONM85P R EP Repeater consists of one 850 MHz and one 900 MHz path, with the intended use of simultaneous transmission. This Test Report describes only the approval of the 850 MHz path

### 2.1.4 Block diagram of measurement reference points

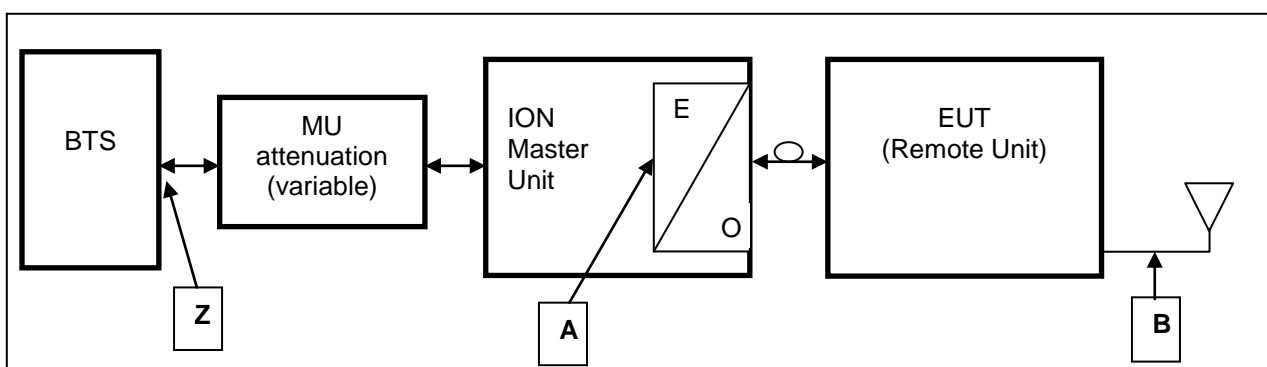

figure 2.1.4-#1 Block diagram of measurement reference points

Remote Unit is the EUT

O/E                      Optical / Electrical converter  
 SRMU                   Sub Rack Master Unit

Reference point A	SRMU	UL output,	DL input
Reference point B	Remote Unit	DL output,	UL input
Reference point Z	BTS	DL output,	UL input

Downlink:                      Measure from reference point A to B

Since a signal generator does not supply a good output signal with +33 or +43dBm, for the downlink measurement the MU Attenuation is not used. That means for downlink measurements the signal generator is connected to measurement point A at the master optical / electrical converter and the analyzer to the measurement point B at the RU.



Test Report No.: 12-227

FCC ID: XS5-M85PR

IC ID: 2237E- M85PR



**BUREAU  
VERITAS**

### 2.1.5 Downlink System Gain and Output Power

System optimized for BTS power (fixed value) <b>Z</b>	MU Attenuation (manual leveling)	Maximum rated input power at the MU OTRX (fixed value) <b>A</b>	RU Gain (fixed value) <b>A to B</b>	Maximum rated output power at RU Antenna port (fixed value) <b>B</b>
<b>+33 dBm</b>	<b>32 dB</b>	<b>1 dBm</b>	<b>+41.5 dB</b>	<b>+42.5 dBm</b> @ 1 carrier
<b>System Gain Z to A</b>	<b>+9.5 dB</b>			
<b>+43 dBm</b>	<b>42 dB</b>	<b>1 dBm</b>	<b>+41.5 dB</b>	<b>+42.5 dBm</b> @ 1 carrier
<b>System Gain Z to A</b>	<b>-0.5 dB</b>			

table 2.1.5-#1 Equipment under test (E.U.T.) Description Downlink System Gain and Output Power

## 3 Test site (Andrew Buchdorf)

### 3.1 Test environment

All tests were performed under the following environmental conditions:

Condition	Minimum value	Maximum value
Barometric pressure	86 kPa	106 kPa
Temperature	15°C	30°C
Relative Humidity	20 %	75 %
Power supply range	±5% of rated voltages	



### 3.2 Test equipment

ANDREW Inv. No.	Test equipment	Type	Manufacturer	Serial No.	Calibration
9102	Network Analyzer	ZVB 14	R&S	100118	08/13
9054	Spectrum Analyzer	FSV13	R&S	100859	12/12
9046	Signal Generator	SMBV100A	R&S	255090	06/13
9123	Signal Generator	SMBV100A	R&S	257408	11/12
8671	Power Meter	E4418B	Agilent	GB39513094	06/12
8672	Power Sensor	E9300H	Agilent	US41090179	06/12
7336	Power Attenuator	768-20	Narda	04904	CIU
7119	Divider	2way	Mikom	3512	CIU
7408	RF-Cable	2,0m; N-N	Andrew	---	CIU
7409	RF-Cable	2,0m; N-N	Andrew	---	CIU
7410	RF-Cable	1,0m; N-N	Andrew	---	CIU
7411	RF-Cable	2,0m; N-N	Andrew	---	CIU
7373	RF-Cable	Multiflex141	Andrew	---	CIU
7374	RF-Cable	Multiflex141	Andrew	---	CIU
7437	RF-Cable	Multiflex141	Andrew	---	CIU
7438	RF-Cable	Multiflex141	Andrew	---	CIU
7439	RF-Cable	Multiflex141	Andrew	---	CIU
7443	RF-Cable	Multiflex141	Andrew	---	CIU
7444	RF-Cable	Multiflex141	Andrew	---	CIU
7445	RF-Cable	Multiflex141	Andrew	---	CIU
7446	RF-Cable	Multiflex141	Andrew	---	CIU
7447	RF-Cable	Multiflex141	Andrew	---	CIU
7448	RF-Cable	Multiflex141	Andrew	---	CIU
7449	RF-Cable	Multiflex141	Andrew	---	CIU
7450	RF-Cable	Multiflex141	Andrew	---	CIU
7440	RF-Cable	RG-223 0.8m	Andrew	---	CIU
7441	RF-Cable	RG-223 0.8m	Andrew	---	CIU

CIU = Calibrate in use

### 3.3 Input and output losses

All recorded power levels should be referenced to the input and output connectors of the repeater, unless explicitly stated otherwise.

The test equipment used in this test has to be calibrated, so that the functionality is also checked.

All cables, attenuators, splitter, isolator, circulator and combiner etc. must be measured before testing and used for compensation during testing.

### 3.4 Measurement uncertainty

The extended measurement uncertainty corresponds to the measurement results from the standard measurement uncertainty multiplied by the coverage factor  $k=2$ . The true value is located in the corresponding interval with a probability of 95 %.

Test Report No.: 12-227

FCC ID: XS5-M85PR

IC ID: 2237E- M85PR



BUREAU  
VERITAS

## 4 Test site (Bureau Veritas)

FCC Test site: 96997  
IC OATS: 2237E

See relevant dates under section 12.



## 5 RF Power Out: §22.913, §2.1046; IC RSS-131

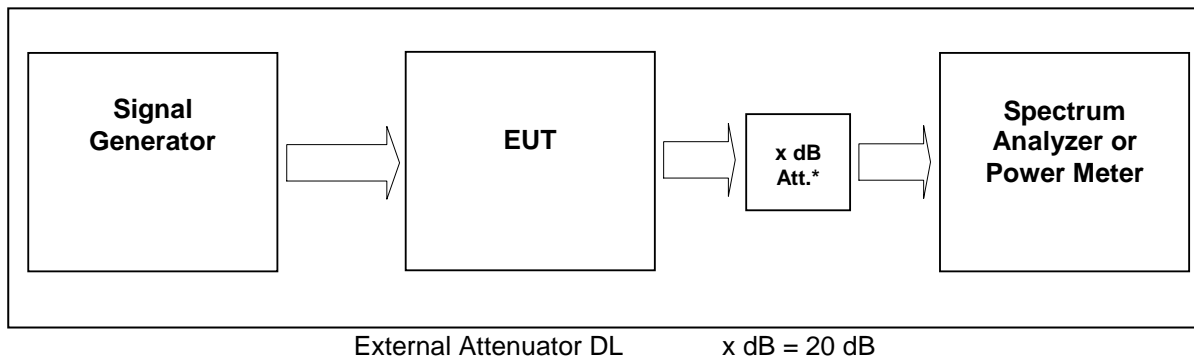

figure 5-#1 Test setup: **RF Power Out: §22.913, §2.1046; IC RSS-131**

Measurement uncertainty	± 0,38 dB
Test equipment used	9054, 9046, 7336, 7119, 7409, 7449, 7443, 7444,

### 5.1 Limit

Minimum standard:

Para. No.22.913

The effective radiated power (ERP) of transmitters in the Cellular Radiotelephone Service must not exceed the limits in this section.

(a) *Maximum ERP.* In general, the effective radiated power (ERP) of base transmitters and cellular repeaters must not exceed 500 Watts. However, for those systems operating in areas more than 72 km (45 miles) from international borders that:

- (1) Are located in counties with population densities of 100 persons or fewer per square mile, based upon the most recently available population statistics from the Bureau of the Census; or,
- (2) Extend coverage on a secondary basis into cellular unserved areas, as those areas are defined in § 22.949, the ERP of base transmitters and cellular repeaters of such systems must not exceed 1000 Watts. The ERP of mobile transmitters and auxiliary test transmitters must not exceed 7 Watts.

### 5.2 Test method

§ 2.1046 Measurements required: RF power output.

(a) For transmitters other than single sideband, independent sideband and controlled carrier radiotelephone, power output shall be measured at the RF output terminals when the transmitter is adjusted in accordance with the tune-up procedure to give the values of current and voltage on the circuit elements specified in § 2.1033(c)(8). The electrical characteristics of the radio frequency load attached to the output terminals when this test is made shall be stated.

(c) For measurements conducted pursuant to paragraphs (a) and (b) of this section, all calculations and methods used by the applicant for determining carrier power or peak envelope power, as appropriate, on the basis of measured power in the radio frequency load attached to the transmitter output terminals shall be shown. Under the test conditions specified, no components of the emission spectrum shall exceed the limits specified in the applicable rule parts as necessary for meeting occupied bandwidth or emission limitations

**Test Report No.: 12-227**

**FCC ID: XS5-M85PR**

**IC ID: 2237E- M85PR**



**BUREAU  
VERITAS**

---

### **5.3 Test Results**

Detector RMS.

#### **Test signal CDMA**

Signal waveform according to table 6.2-1 of standard specification 3GPP2 C.p0051-0 v1.0 16.February 2006 pilot, sync, paging, 37 traffics, which is equal to the table 6.5.2.1 of 3GPP2 C.S0010-C v2.0 24.February 2006.

#### **Test signal WCDMA**

Signal waveform according to Test Model 1 of standard specification 3GPP TS25.141. Signal modulated with a combination of PCCPCH, SCCPCH and Dedicated Physical Channels specified as test model 1 64 DPCH.

#### **Test signal LTE:**

Signal waveform according to Test Model 1.1, E-TM1.1, clause 6.1.1.1-1, table 6.1.1.1-1 of standard specification 3GPP TS 36.141 V9.3.0 (2010-03).



**5.3.1 Downlink**

Modulation	Measured at		RBW VBW Span	RF Power [dBm]	RF Power [W]	Plot -
CDMA	Middle	876.25 MHz	3MHz 10MHz 15MHz	42.5	17.8	5.3.1.1 #1
WCDMA	Middle	876.25 MHz	10MHz 10MHz 50MHz	42.5	17.8	5.3.1.2 #1
LTE	Middle	876.25 MHz	3MHz 10MHz 15MHz	42.5	17.8	5.3.1.3 #1
Maximum output power = 42.5 dBm = 39.8 W						
Limit Maximum output power = 57 dBm = 500 W						

table 5.3.1-#1 RF Power Out: §22.913, §2.1046; IC RSS-131 Test Results Downlink

The max RF Power out is 42.5 dBm, so the maximum antenna gain (x) can be calculated as follow:

**Limit = 500W (erp) = 57 dBm**

57 dBm > 42.5 dBm + x

**14.5 dBd = 13.65 dBi > x**

=> The antenna that will use for the complete system have to have a gain lower than 13.65 dBi, relative to a dipol.

Modulation	Pin / dBm (Ref. point B)
CDMA	0.5
WCDMA	0.5
LTE	0.4

table 5.3.1-#2 RF Power Out: §22.913, §2.1046; IC RSS-131 Test Results Downlink Input power



5.3.1.1 CDMA

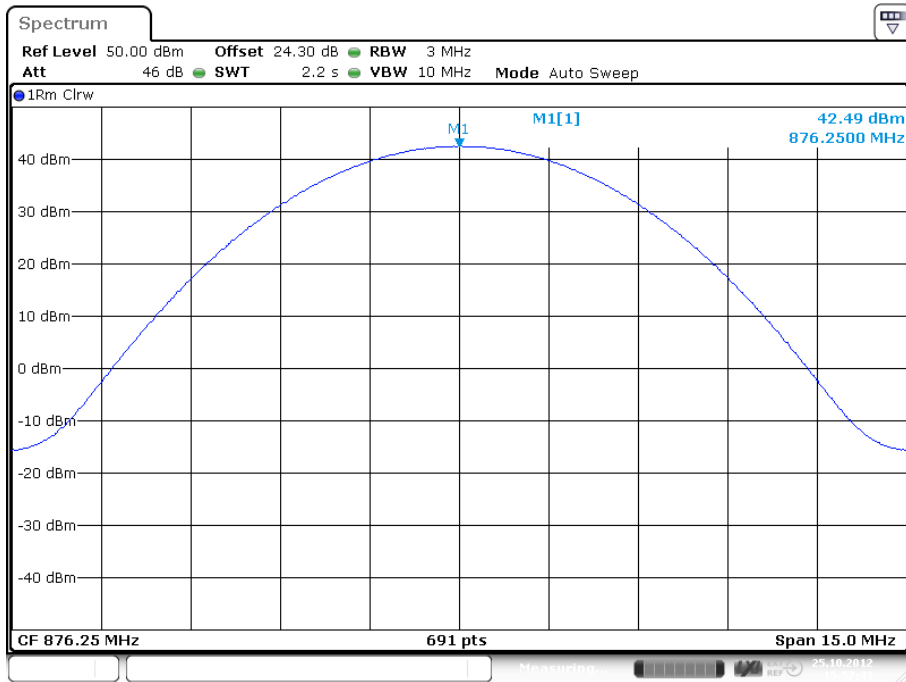

plot 5.3.1.1-#1 RF Power Out: §22.913, §2.1046; IC RSS-131; Test Results; Downlink; CDMA Middle

5.3.1.2 WCDMA

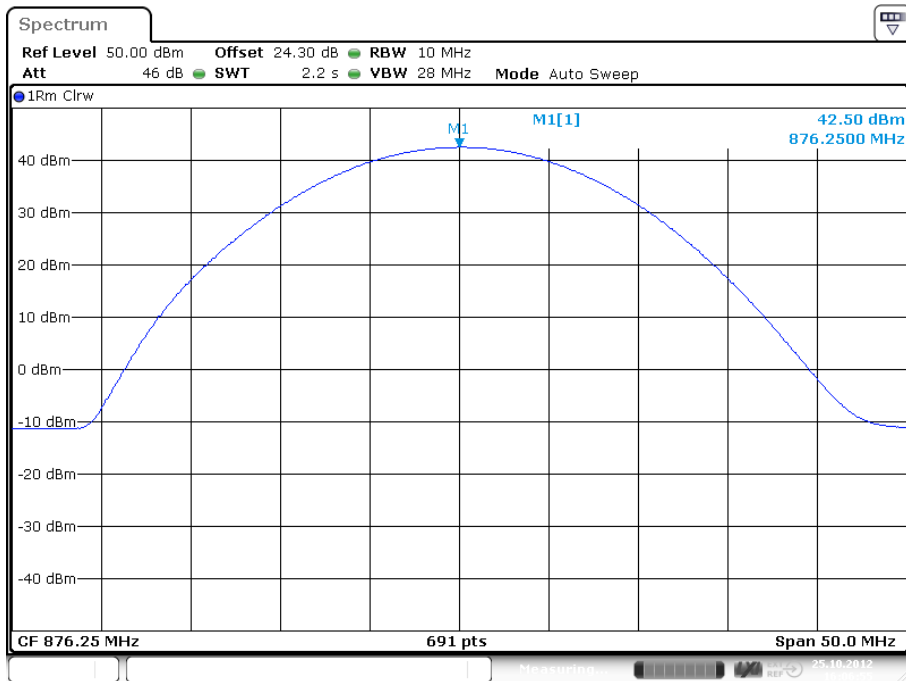

plot 5.3.1.2-#1 RF Power Out: §22.913, §2.1046; IC RSS-131; Test Results; Downlink; WCDMA Middle



**5.3.1.3 LTE**

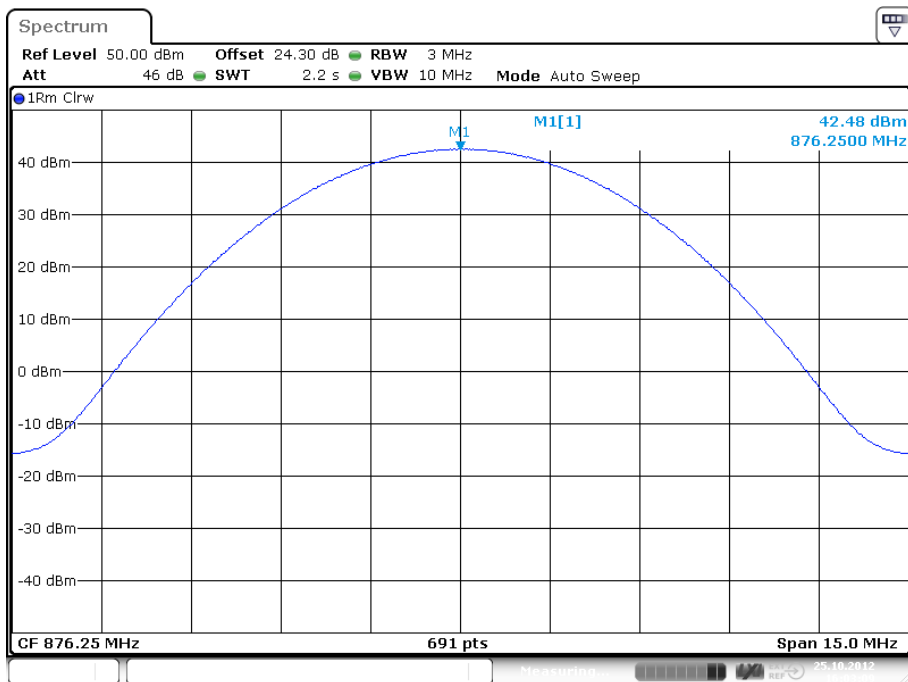

Date: 25.OCT.2012 16:03:10

plot 5.3.1.3-#1 RF Power Out: §22.913, §2.1046; IC RSS-131; Test Results; Downlink; LTE Middle

**5.3.2 Uplink**

n.a.

Note: The EUT does not transmit over the air in the uplink direction.

**5.4 Summary test result**

Test result	complies, according the plots above
Tested by:	M. Leinfelder
Date:	25.10.2012





## 6 Occupied Bandwidth: §2.1049; RSS-GEN

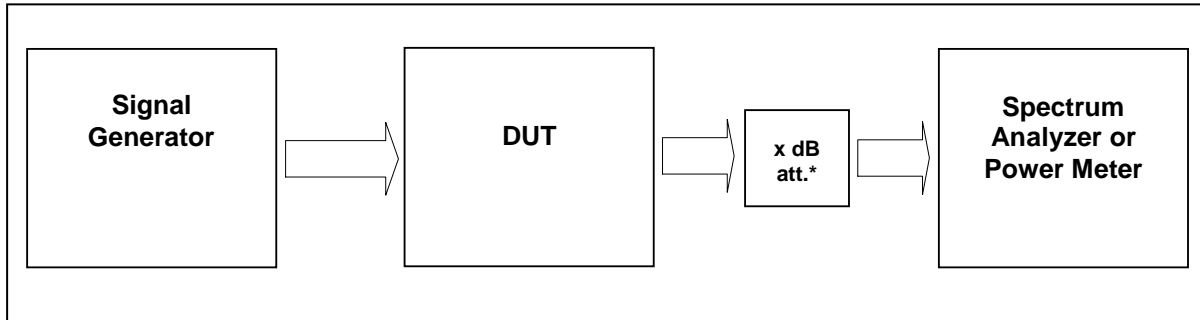

External Attenuator DL      x dB = 20 dB  
 figure 6-#1 Test setup: **Occupied Bandwidth: §2.1049; RSS-GEN**

Measurement uncertainty	± 0,38 dB
Test equipment used	9054, 9046, 7336, 7119, 7409, 7449, 7443, 7444,

### 6.1 Limit

The spectral shape of the output should look similar to input for all modulations.

### 6.2 Test method

Para. No.2.1049

The occupied bandwidth, that is the frequency bandwidth such that, below its lower and above its upper frequency limits, the mean powers radiated are each equal to 0.5 percent of the total mean power radiated by a given emission shall be measured under the following conditions as applicable:

### 6.3 Test results

For composite power measurements: Detector RMS.



**6.3.1 Downlink**

Modulation	Measured at		RBW VBW Span	Occupied Bandwidth	Plot #
CDMA	Middle	881,5 MHz	30 kHz 300 kHz 5 MHz	1.27 MHz	6.3.1.1 #1, #2
WCDMA	Middle	881,5 MHz	100 kHz 1 MHz 10 MHz	4.18 MHz	6.3.1.2 #1, #2
LTE	Middle	881,5 MHz	30 kHz 300 kHz 5 MHz	1.1 MHz	6.3.1.3 #1, #2

table 6.3-#1 **Occupied Bandwidth: §2.1049; RSS-GEN Test results**



6.3.1.1 CDMA

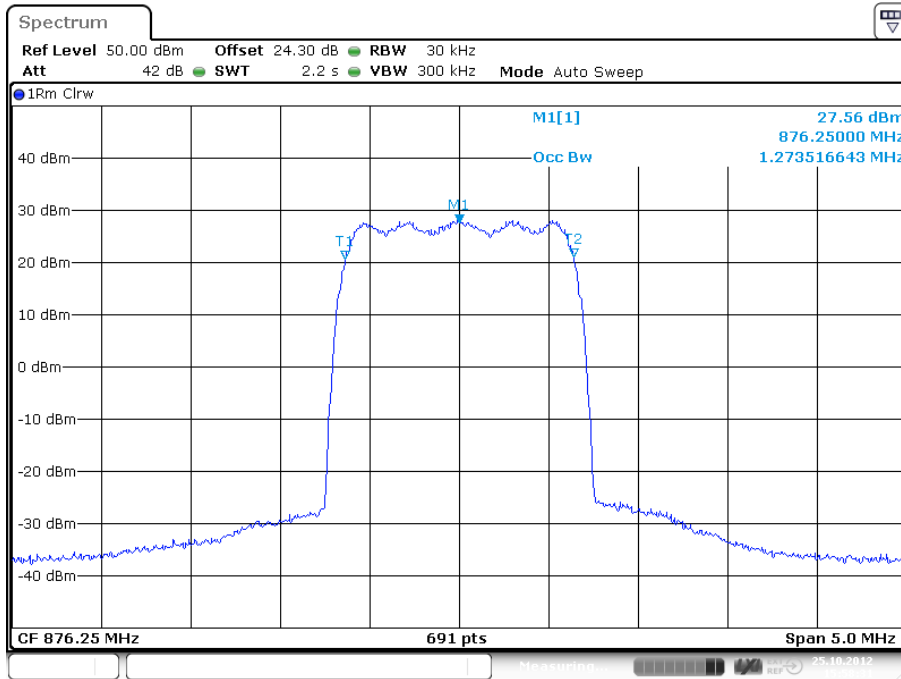

Date: 25.OCT.2012 15:58:31

plot 6.3.1.1-#1 Occupied Bandwidth: \$2.1049; RSS-GEN; Test results; Downlink; CDMA Output

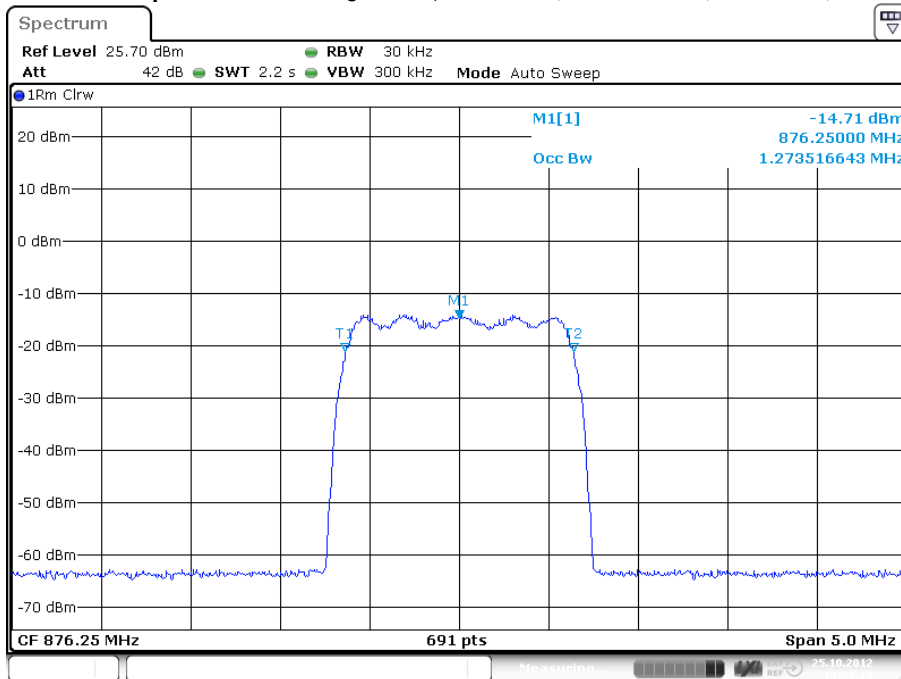

Date: 25.OCT.2012 15:59:11

plot 6.3.1.1-#2 Occupied Bandwidth: \$2.1049; RSS-GEN; Test results; Downlink; CDMA Input



### 6.3.1.2 WCDMA

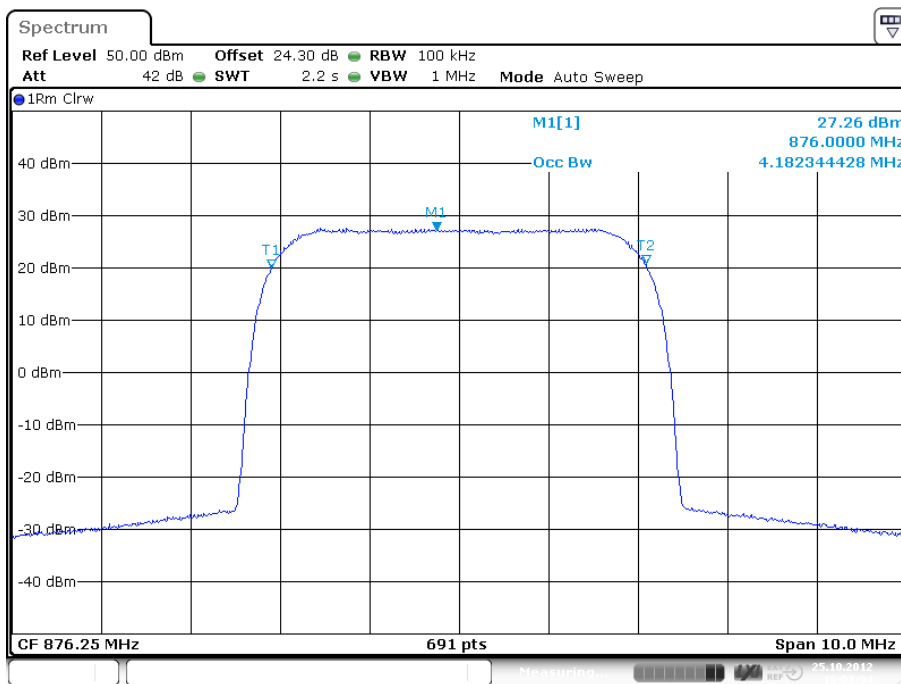

Date: 25.OCT.2012 16:08:04

plot 6.3.1.2-#1 Occupied Bandwidth: \$2.1049; RSS-GEN; Test results; Downlink; WCDMA Output

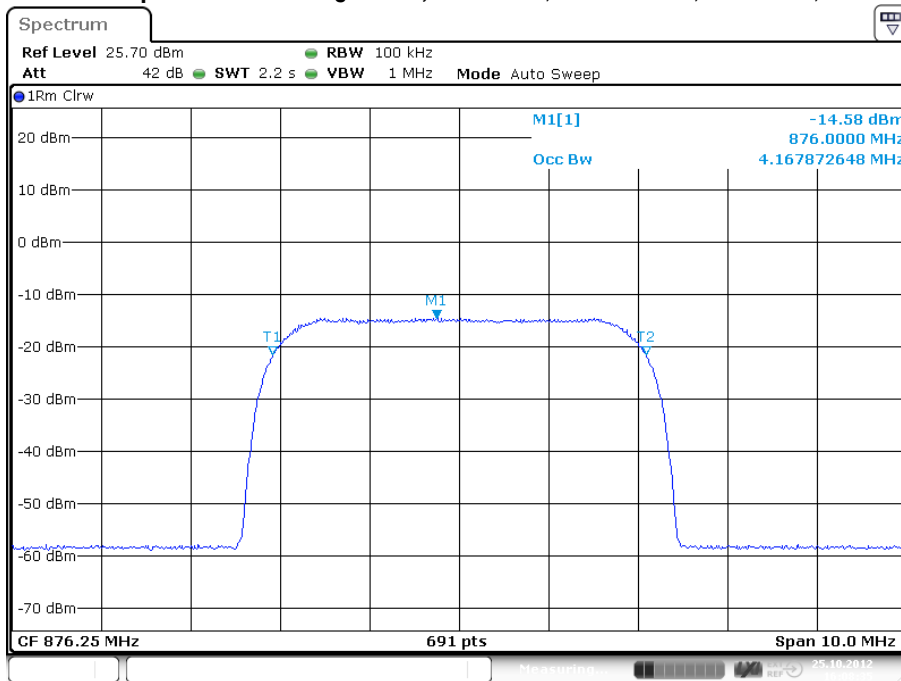

Date: 25.OCT.2012 16:08:36

plot 6.3.1.2-#2 Occupied Bandwidth: \$2.1049; RSS-GEN; Test results; Downlink; WCDMA Input



6.3.1.3 LTE

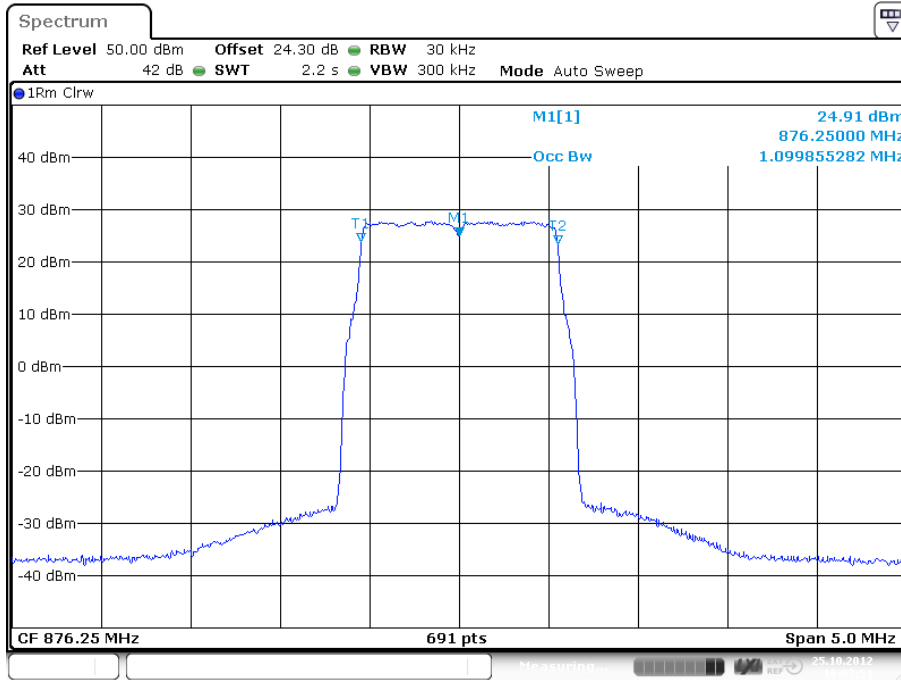

Date: 25.OCT.2012 16:03:52

plot 6.3.1.3-#1 Occupied Bandwidth: \$2.1049; RSS-GEN; Test results; Downlink; LTE Output

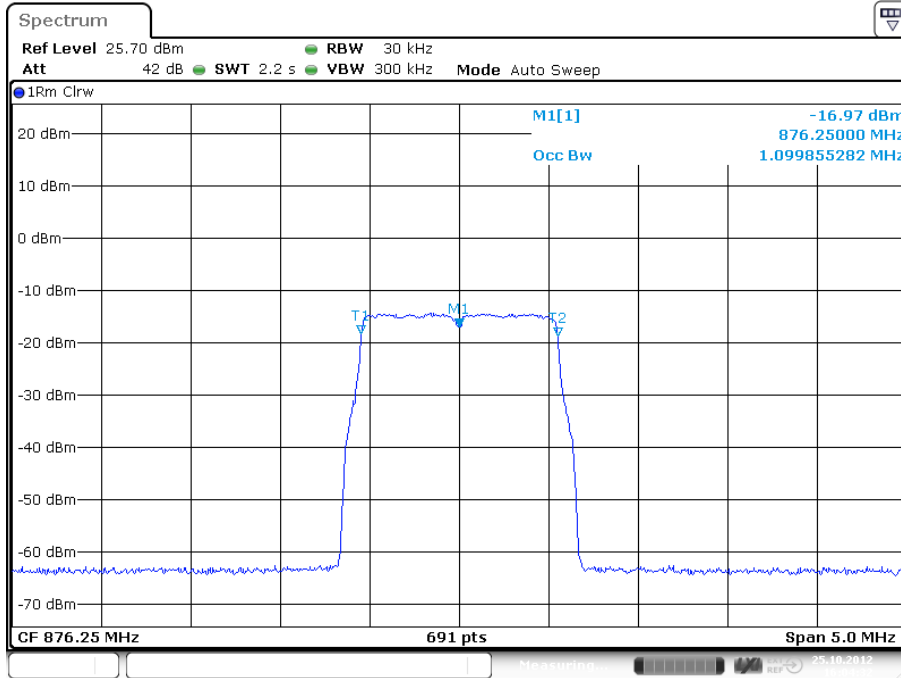

Date: 25.OCT.2012 16:04:32

plot 6.3.1.3-#2 Occupied Bandwidth: \$2.1049; RSS-GEN; Test results; Downlink; LTE Input

Test Report No.: 12-227

FCC ID: XS5-M85PR

IC ID: 2237E- M85PR



**BUREAU**  
**VERITAS**

### 6.3.2 Uplink

n.a.

Note: The EUT does not transmit over the air in the uplink direction.

### 6.4 Summary test result

Test result	complies, according the plots above
Tested by:	M. Leinfelder
Date:	25.10.2012



## 7 Spurious Emissions at Antenna Terminals: §22.917, §2.1051; RSS-131, RSS-GEN

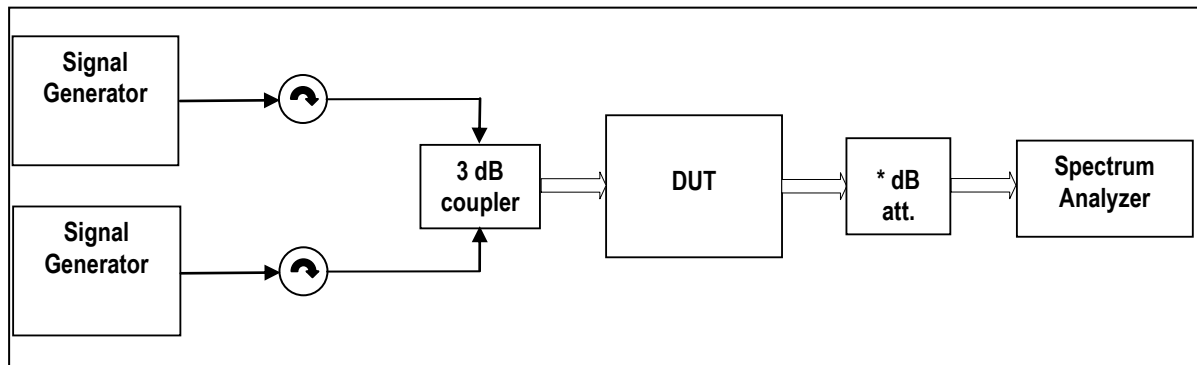

figure 7-#1 Test setup: **Spurious Emissions at Antenna Terminals: §22.917, §2.1051; RSS-131, RSS-GEN**

Measurement uncertainty	± 0,54 dB ± 1,2 dB ± 1,5 dB	9 kHz to 3 GHz 3 GHz to 7 GHz 7 GHz to 26 GHz
Test equipment used	9054, 9046,9123, 7336, 7119, 7409, 7449, 7443, 7444,	

### 7.1 Limit

Minimum standard:

Para. No.22.917

(a) *Out of band emissions.* The power of any emission outside of the authorized operating frequency ranges must be attenuated below the transmitting power (P) by a factor of at least  $43 + 10 \log(P)$  dB.

(b) *Measurement procedure.* Compliance with these rules is based on the use of measurement instrumentation employing a resolution bandwidth of 100 kHz or greater. In the 1 MHz bands immediately outside and adjacent to the frequency block a resolution bandwidth of at least one percent of the emission bandwidth of the fundamental emission of the transmitter may be employed. A narrower resolution bandwidth is permitted in all cases to improve measurement accuracy provided the measured power is integrated over the full required measurement bandwidth (*i.e.* 100 kHz or 1 percent of emission bandwidth, as specified). The emission bandwidth is defined as the width of the signal between two points, one below the carrier center frequency and one above the carrier center frequency, outside of which all emissions are attenuated at least 26 dB below the transmitter power.

### 7.2 Test method

Para. No 2.1051 Measurements required: Spurious emissions at antenna terminals.

The radio frequency voltage or powers generated within the equipment and appearing on a spurious frequency shall be checked at the equipment output terminals when properly loaded with a suitable artificial antenna. Curves or equivalent data shall show the magnitude of each harmonic and other spurious emission that can be detected when the equipment is operated under the conditions specified in § 2.1049 as appropriate. The magnitude of spurious emissions which are attenuated more than 20 dB below the permissible value need not be specified.

[39 FR 5919, Feb. 15, 1974. Redesignated and amended at 63 FR 36599, July 7, 1998]



**7.3 Test results**

**7.3.1 Downlink**

<1MHz from Band Edge

Detector: RMS.

Modulation	Measured at Band Edge	Carriers	RBW VBW Span Sweep points	Max. level (dBm)	Plot -
CDMA	Lower Edge Upper Edge	869,775 MHz 871,025 MHz 891,975 MHz 893,225 MHz	30kHz 300kHz 6MHz	-29	7.3.1.1 #1 #2
WCDMA	Lower Edge Upper Edge	871,6 MHz 876,6 MHz 886,4 MHz 891,4 MHz	100kHz 1MHz 15MHz	-28	7.3.1.2 #1 #2
LTE	Lower Edge Upper Edge	869,7 MHz 871,1 MHz 891,9 MHz 893,3 MHz	30kHz 300kHz 6MHz	-28.3	7.3.1.3 #1 #2

table 7.3-#1 Spurious Emissions at Antenna Terminals: §22.917, §2.1051; RSS-131, RSS-GEN Test results <1MHz from Band Edge

>1MHz from Band Edge

Detector: RMS.

Modulation	Carrier	RBW VBW Span	Max. level (dBm)	Plot -
CDMA	881,5 MHz	1MHz 3MHz 30MHz – 10GHz	-33.2	7.3.1.4 #1
WCDMA	881,5 MHz	1MHz 3MHz 30MHz – 10GHz	-33.3	7.3.1.5 #1
LTE	881,5 MHz	1MHz 3MHz 30MHz – 10GHz	-33.2	7.3.1.6 #1

table 7.3-#2 Spurious Emissions at Antenna Terminals: §22.917, §2.1051; RSS-131, RSS-GEN Test results <1MHz from Band Edge





7.3.1.1 CDMA < 1MHz to band edge

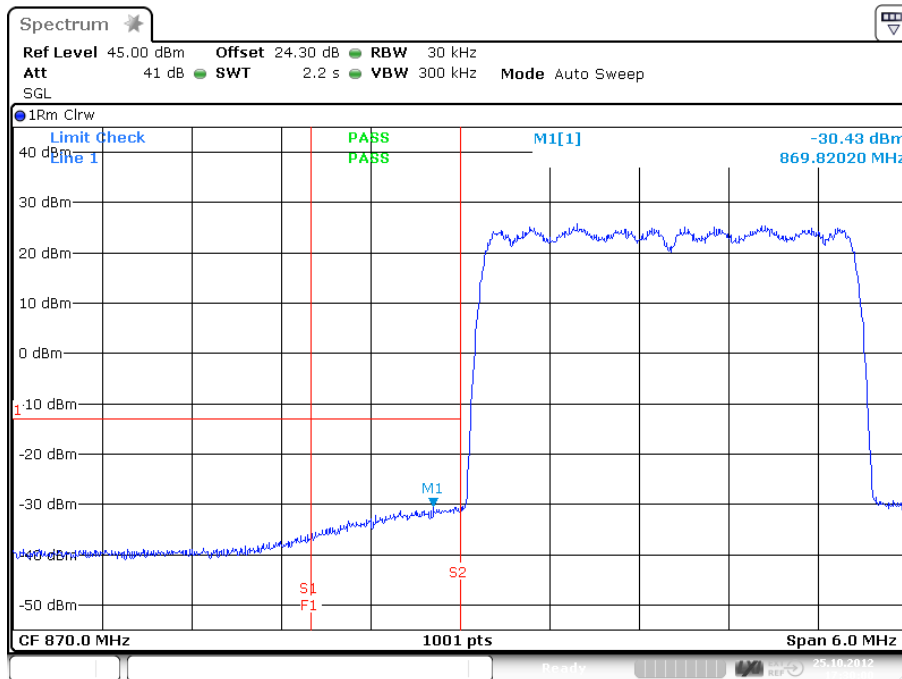

Date: 25.OCT.2012 17:30:00

plot 7.3.1.1-#1 Spurious Emissions at Antenna Terminals: §22.917, §2.1051; RSS-131, RSS-GEN; Test results; Downlink; CDMA < 1MHz to band edge Lower Band Edge

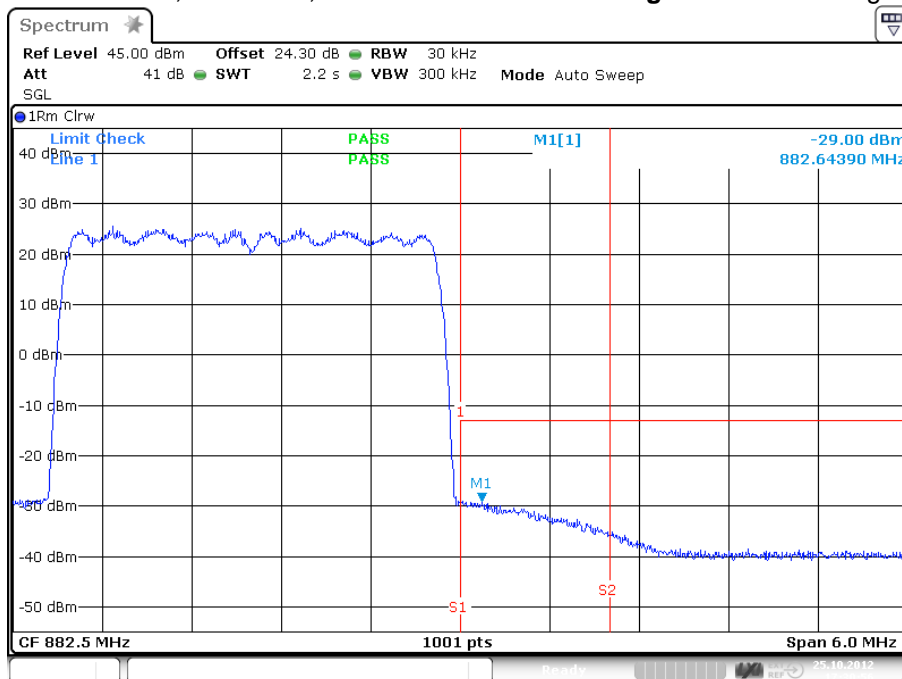

Date: 25.OCT.2012 17:30:57

plot 7.3.1.1-#2 Spurious Emissions at Antenna Terminals: §22.917, §2.1051; RSS-131, RSS-GEN; Test results; Downlink; CDMA < 1MHz to band edge Upper Band Edge



7.3.1.2 WCDMA < 1MHz to band edge

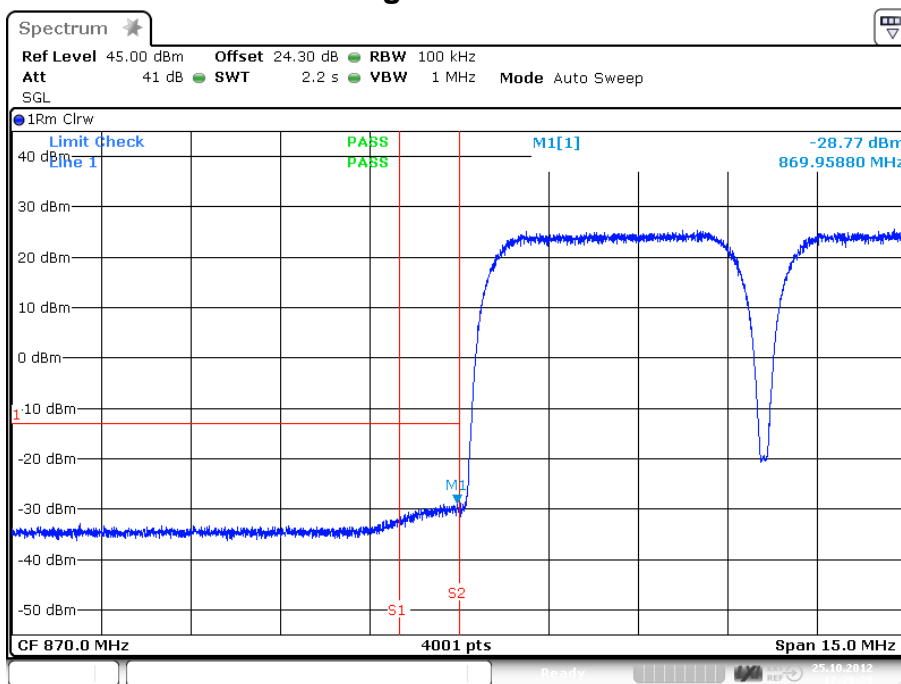

Date: 25.OCT.2012 17:39:28

plot 7.3.1.2-#1 Spurious Emissions at Antenna Terminals: §22.917, §2.1051; RSS-131, RSS-GEN; Test results; Downlink; WCDMA < 1MHz to band edge Lower Band Edge

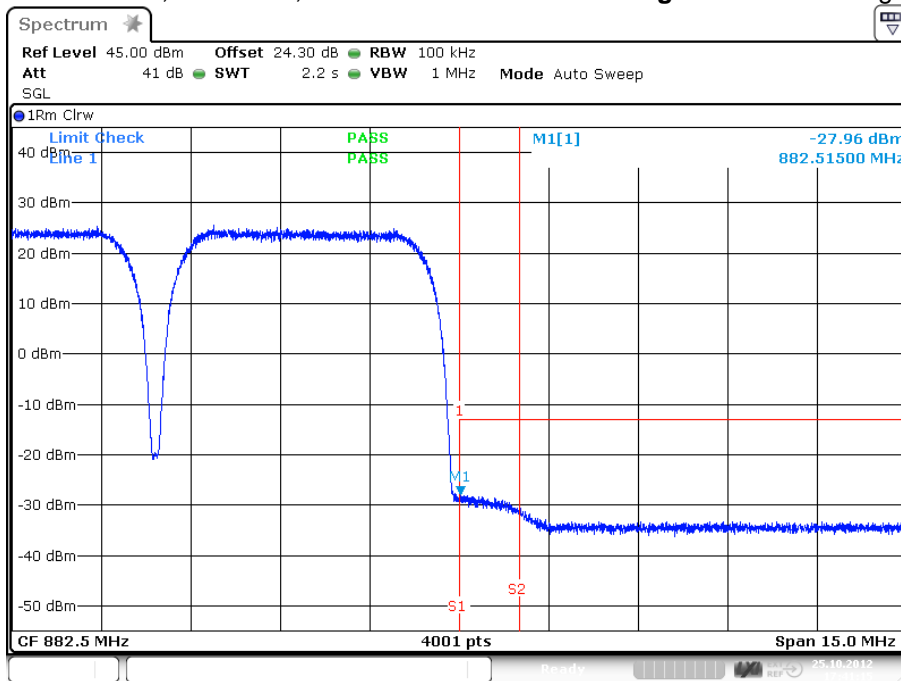

Date: 25.OCT.2012 17:41:16

plot 7.3.1.2-#2 Spurious Emissions at Antenna Terminals: §22.917, §2.1051; RSS-131, RSS-GEN; Test results; Downlink; WCDMA < 1MHz to band edge Upper Band Edge



7.3.1.3 LTE < 1MHz to band edge

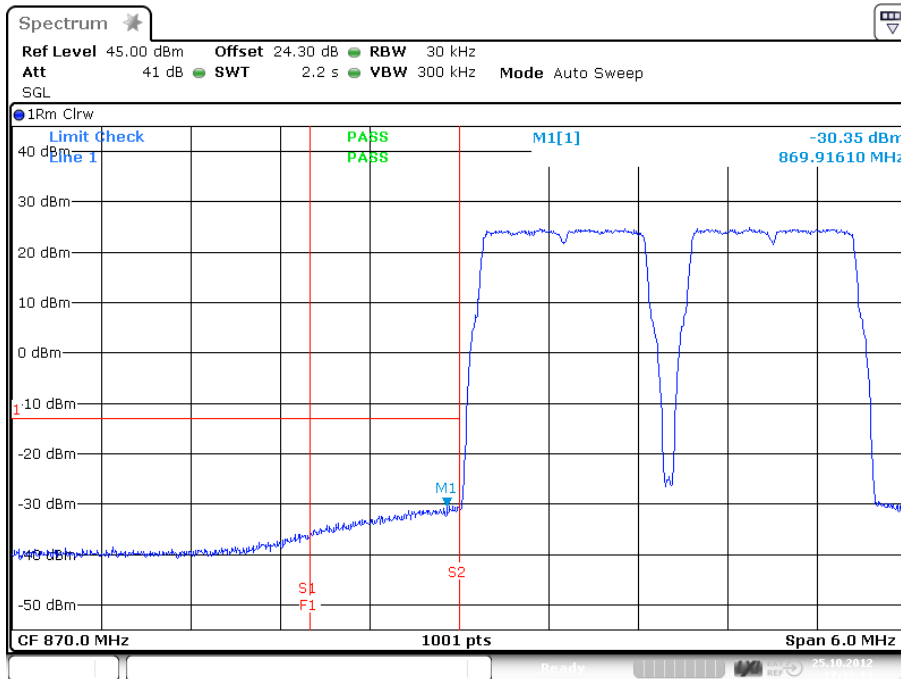

Date: 25.OCT.2012 17:33:32

plot 7.3.1.3-#1 Spurious Emissions at Antenna Terminals: \$22.917, \$2.1051; RSS-131, RSS-GEN; Test results; Downlink; LTE < 1MHz to band edge Lower Band Edge

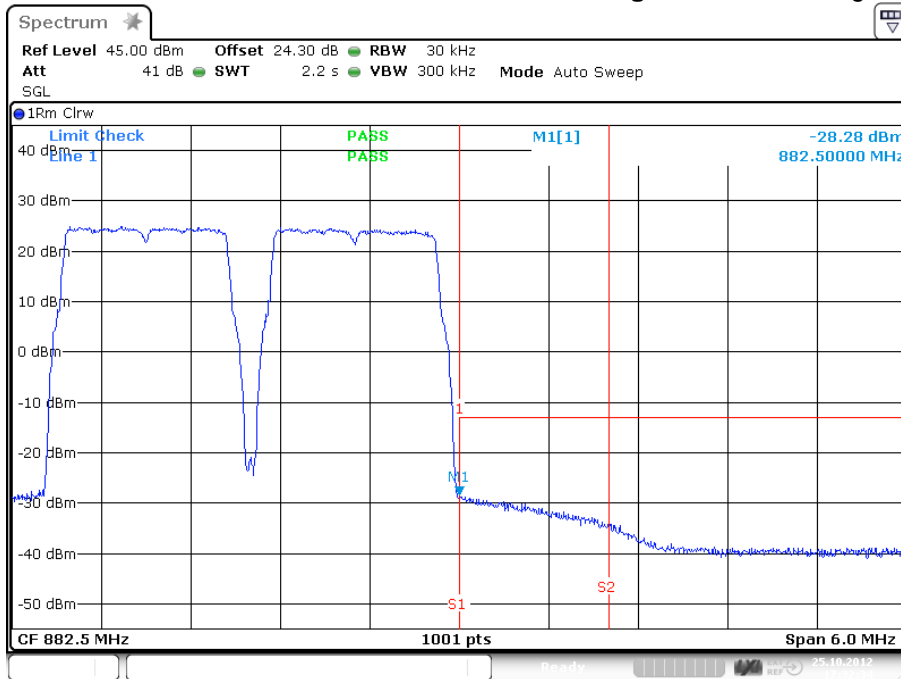

Date: 25.OCT.2012 17:32:35

plot 7.3.1.3-#2 Spurious Emissions at Antenna Terminals: \$22.917, \$2.1051; RSS-131, RSS-GEN; Test results; Downlink; LTE < 1MHz to band edge Upper Band Edge



### 7.3.1.4 CDMA > 1MHz to band edge

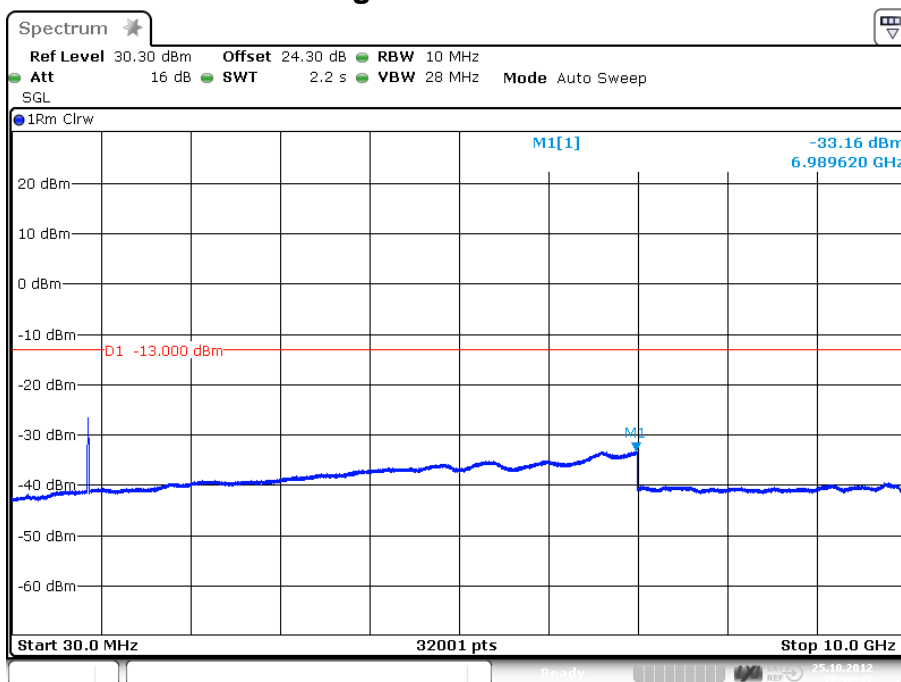

Date: 25.OCT.2012 17:10:13

plot 7.3.1.4-#1 Spurious Emissions at Antenna Terminals: §22.917, §2.1051; RSS-131, RSS-GEN; Test results; Downlink; CDMA > 1MHz to band edge; carrier (876.25MHz) notched

### 7.3.1.5 WCDMA > 1MHz to band edge

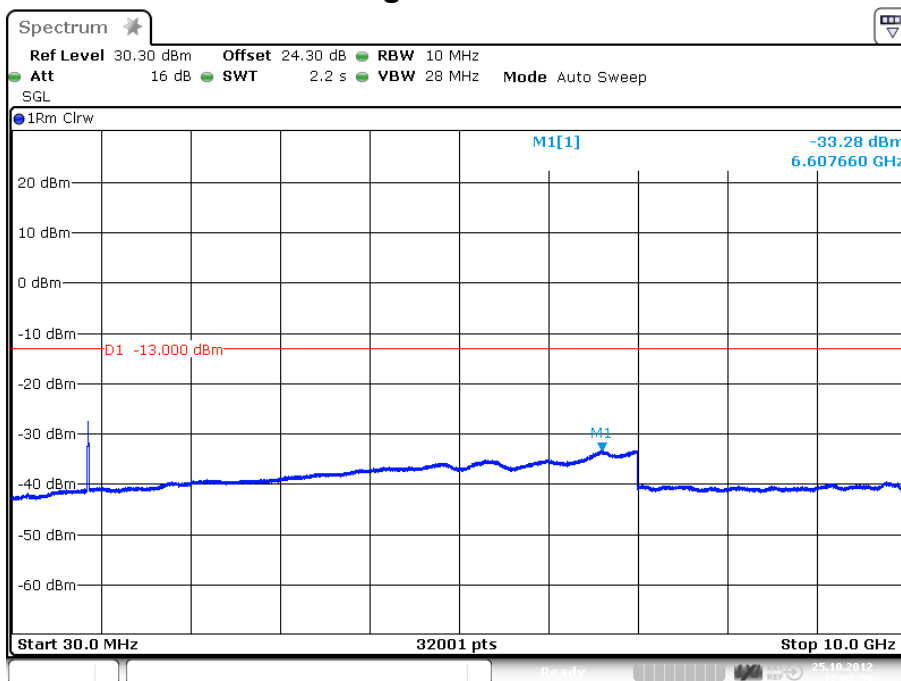

Date: 25.OCT.2012 17:06:59

plot 7.3.1.5-#1 Spurious Emissions at Antenna Terminals: §22.917, §2.1051; RSS-131, RSS-GEN; Test results; Downlink; WCDMA > 1MHz to band edge; carrier (876.25MHz) notched



**7.3.1.6 LTE > 1MHz to band edge**

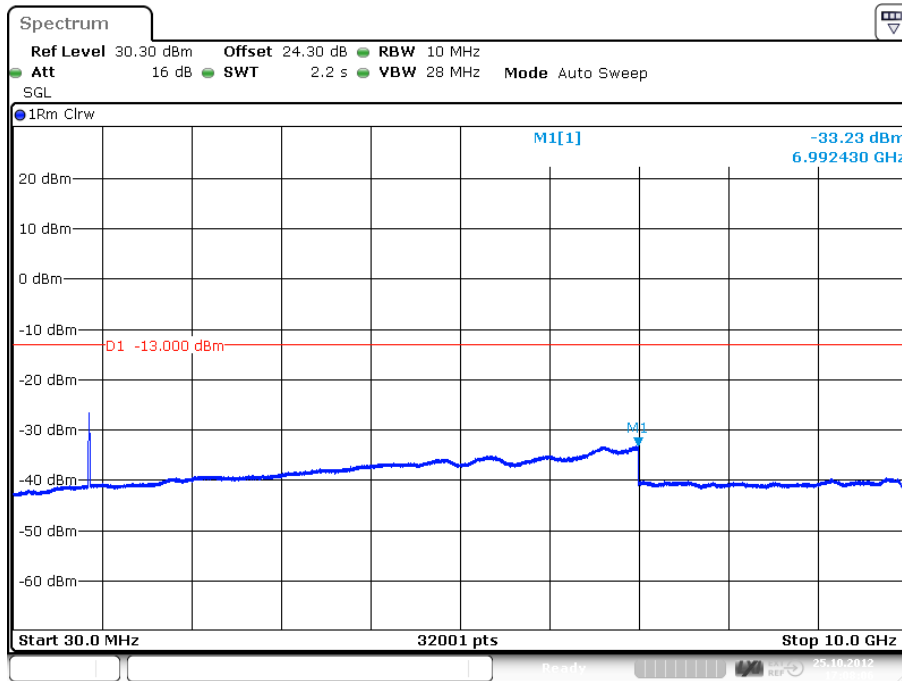

plot 7.3.1.6-#1 **Spurious Emissions at Antenna Terminals: §22.917, §2.1051; RSS-131, RSS-GEN;**  
**Test results; Downlink; LTE > 1MHz to band edge; carrier (876.25MHz) notched**

**7.3.2 Uplink**

n.a.

Note: The EUT does not transmit over the air in the uplink direction.

**7.4 Summary test result**

Test result	complies, according the plots above
Tested by:	M. Leinfelder
Date:	25.10.2012

## 8 Amplifier Gain and Bandwidth: IC RSS-131

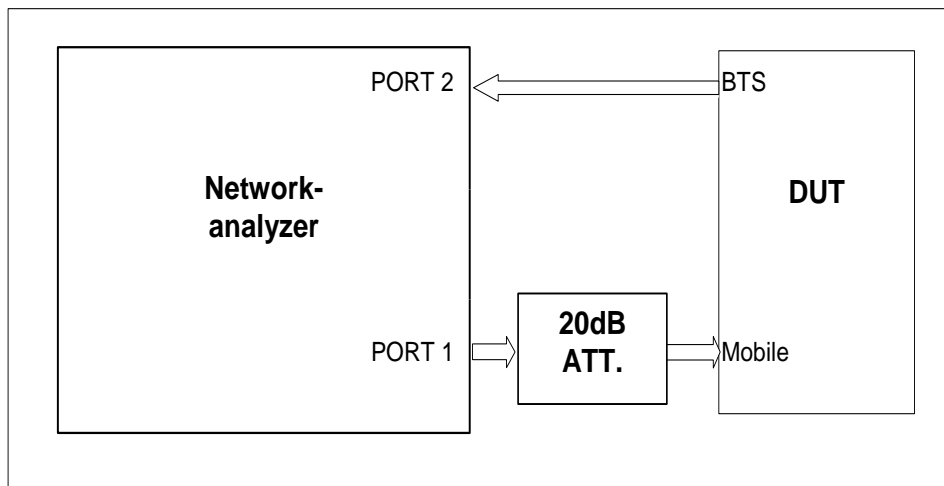

figure 8-#1 Test setup: **Amplifier Gain and Bandwidth: IC RSS-131**

Test equipment used	9102, 7336, 7409, 7449, 7443, 7444,
---------------------	-------------------------------------

### 8.1 Limit

IC RSS-131 clause 6.1

The passband gain shall not exceed the nominal gain by more than 1.0 dB. The 20 dB bandwidth shall not exceed the nominal bandwidth that is stated by the manufacturer. Outside of the 20 dB bandwidth, the gain shall not exceed the gain at the 20 dB point.

### 8.2 Test method

IC RSS-131 clause 4.2

Adjust the internal gain control of the equipment under test to the nominal gain for which equipment certification is sought.

With the aid of a signal generator and spectrum analyser, measure the 20 dB bandwidth of the amplifier (i.e. at the point where the gain has fallen by 20 dB). Measure the gain-versus-frequency response of the amplifier from the midband frequency  $f_0$  of the pass band up to at least  $f_0 \pm 250\%$  of the 20 dB bandwidth.

### 8.3 Test results

#### 8.3.1 Downlink

Passband gain	42.0 dB
Lower limit of 20dB Bandwidth	868.1 MHz
Upper limit of 20dB Bandwidth	884.1 MHz
20dB Bandwidth	15.9 MHz

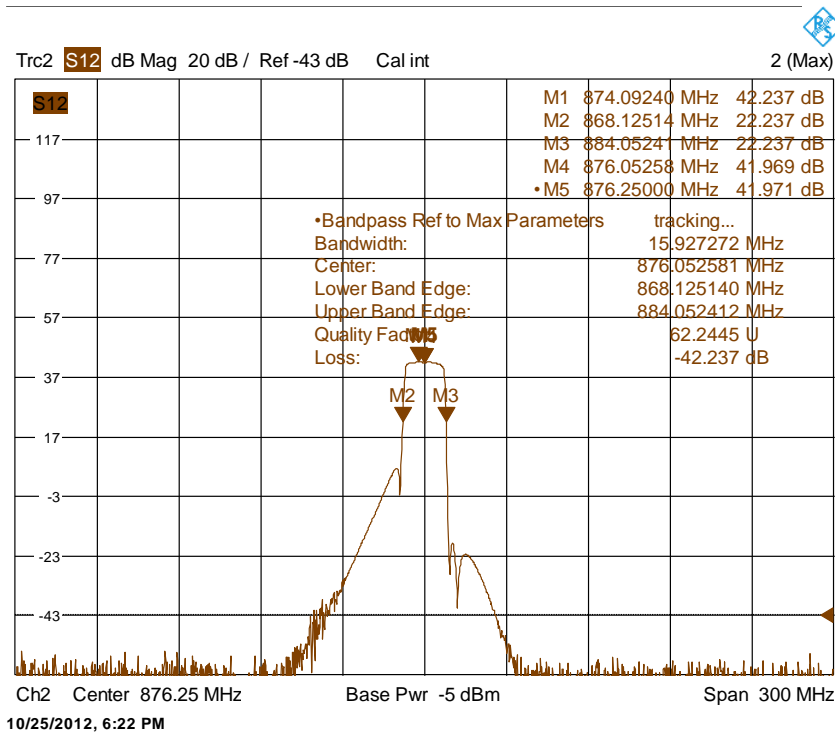

plot 8.3.1-#1 Amplifier Gain and Bandwidth: IC RSS-131; Test results; Downlink

### 8.3.2 Uplink

n.a.

Note: The EUT does not transmit over the air in the uplink direction.

### 8.4 Summary test result

Test result	complies, according the plots above
Tested by:	M. Leinfelder
Date:	25.10.2012



## 9 Output Power: IC RSS-131

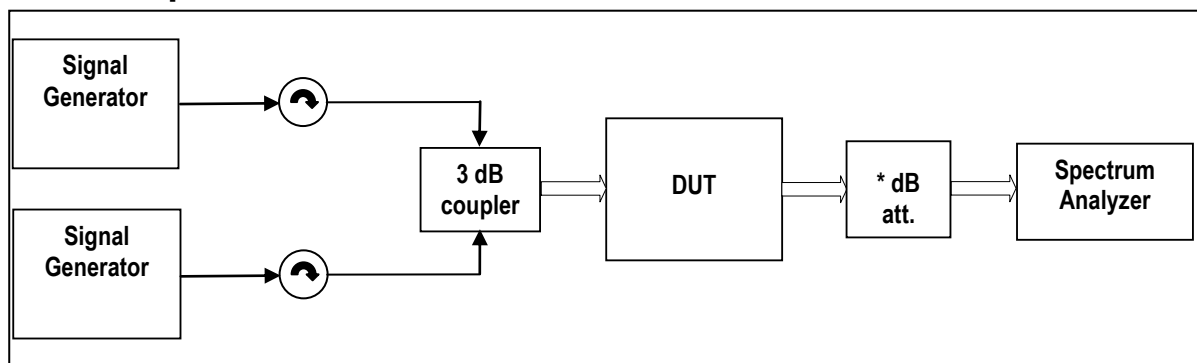

External Attenuator DL x dB = 20 dB  
figure 9-#1 Test setup: **Output Power: IC RSS-131**

Measurement uncertainty	± 0,38 dB
Test equipment used	9054, 9046, 9123, 7336, 7119, 7409, 7449, 7443, 7444,

### 9.1 Limit

IC RSS-131 clause 6.2

The manufacturer's output power rating P rated MUST NOT be greater than P mean for all types of enhancers.

### 9.2 Test method

IC RSS-131 clause 4.3.1 Multi-channel Enhancer

The following subscript "o" denotes a parameter at the enhancer output point.

Connect two signal generators to the input of the Device Under Test (DUT), via a proper impedance matching network (and preferably via a variable attenuator) so that the two input signals are equal sinusoids (and can be raised equally).

Connect a dummy load of suitable load rating to the enhancer output point. Connect also a spectrum analyser to this output point via a coupling network and attenuator, so that only a portion of the output signal is coupled to the spectrum analyser. The coupling attenuation shall be stated in the test report.

Set the two generator frequencies  $f_1$  and  $f_2$  such that they and their third-order intermodulation product frequencies,  $f_3 = 2f_1 - f_2$  and  $f_4 = 2f_2 - f_1$ , are all within the pass band of the DUT.

Raise the input level to the DUT while observing the output tone levels,  $P_{o1}$  and  $P_{o2}$ , and the intermodulation product levels,  $P_{o3}$  and  $P_{o4}$ .

For enhancers rated 500 watts or less: Raise the input level to the DUT until the greater level of the intermodulation products at the enhancer output terminals,  $P_{o3}$  or  $P_{o4}$ , equals -43 dBW.

For enhancers rated over 500 watts: Raise the input level to the DUT until the greater level of the intermodulation products at the enhancer output terminals,  $P_{o3}$  or  $P_{o4}$ , is 67 dB below the level of either output tone level,  $P_{o1}$  or  $P_{o2}$ .

Record all signal levels and their frequencies. Calculate the mean output power ( $P_{mean}$ ) under this





testing condition using  $P_{\text{mean}} = P_{o1} + 3 \text{ dB}$ .

### 9.3 Test results

#### 9.3.1 Downlink

$P_{o1} @ f_1$	39.5 dBm @ 880.25 MHz
$P_{o2} @ f_2$	39.5 dBm @ 882.75 MHz
$P_{o3} @ f_3$	-15.55 dBm @ 877.75 MHz
$P_{o4} @ f_4$	-17.57 dBm @ 885.25 MHz

$$P_{\text{mean}} = P_{o1} + 3 \text{ dB}$$

$$P_{\text{mean}} = 39.5 \text{ dBm} + 3 \text{ dB} = 42.5 \text{ dBm}$$

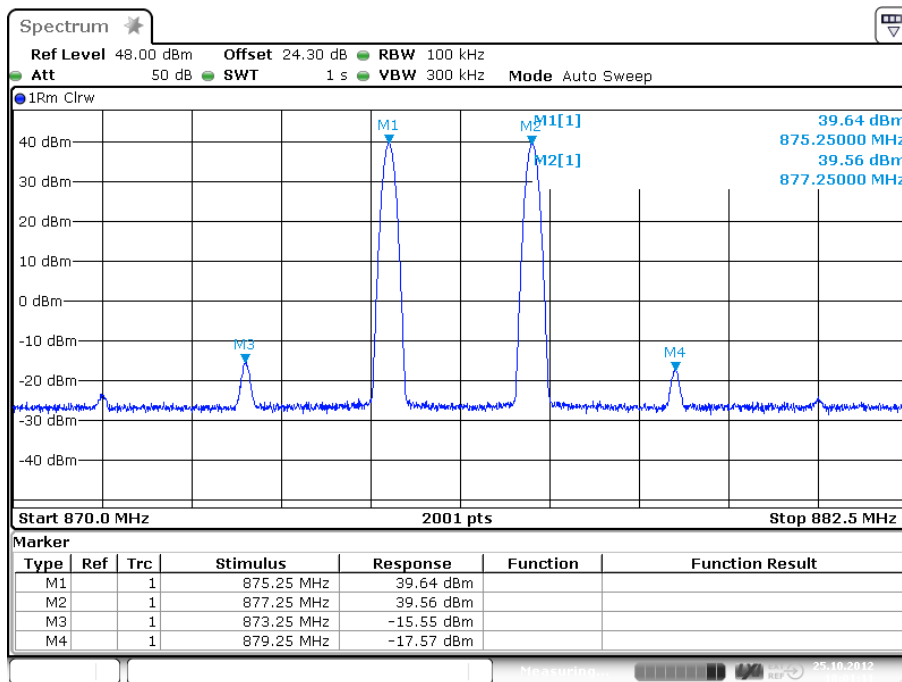

Date: 25.OCT.2012 18:01:12

plot 9.3.1-#1 Output Power: IC RSS-131; Test results; Downlink

#### 9.3.2 Uplink

n.a.

Note: The EUT does not transmit over the air in the uplink direction.

### 9.4 Summary test result

Test result	complies, according the plots above
Tested by:	M. Leinfelder
Date:	25.10.2012



## 10 Non-Linearity: IC RSS-131

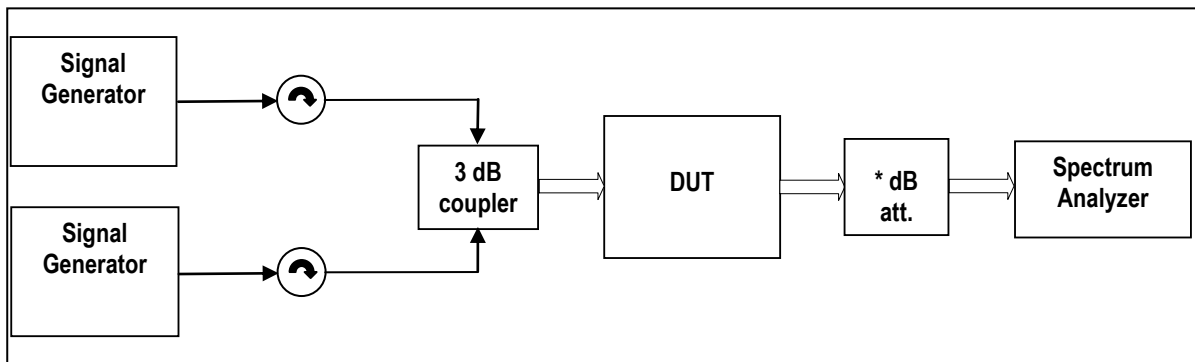

External Attenuator DL x dB = 20 dB  
figure 10-#1 Test setup: **Non-Linearity: IC RSS-131**

Test equipment used	9054, 9046, 9123, 7336, 7119, 7409, 7449, 7443, 7444,
---------------------	---

### 10.1 Limit

RSS-131 clause 6.3

Transmitter signals amplified by a non-linear device (enhancer or translator) will alter the occupied bandwidth of the transmitted signals; therefore, the extent of non-linearity shall be tested.

RSS-131 clause 6.3.1

For a multi-channel enhancer, any intermodulation product level must be attenuated, relative to P, by at least:

$$43 + 10 \text{ Log } 10 P, \text{ or } 70 \text{ dB, whichever is less stringent,}$$

where P is the total RF output power of the test tones in watts.

### 10.2 Test method

IC RSS-131 clause 4.3.1 Multi-channel Enhancer

The following subscript "o" denotes a parameter at the enhancer output point.

Connect two signal generators to the input of the Device Under Test (DUT), via a proper impedance matching network (and preferably via a variable attenuator) so that the two input signals are equal sinusoids (and can be raised equally).

Connect a dummy load of suitable load rating to the enhancer output point. Connect also a spectrum analyser to this output point via a coupling network and attenuator, so that only a portion of the output signal is coupled to the spectrum analyser. The coupling attenuation shall be stated in the test report.

Set the two generator frequencies  $f_1$  and  $f_2$  such that they and their third-order intermodulation product frequencies,  $f_3 = 2f_1 - f_2$  and  $f_4 = 2f_2 - f_1$ , are all within the pass band of the DUT.

Raise the input level to the DUT while observing the output tone levels,  $P_{o1}$  and  $P_{o2}$ , and the intermodulation product levels,  $P_{o3}$  and  $P_{o4}$ .



### 10.3 Test results

#### 10.3.1 Downlink

**Requirement calculation:**

$P = 42.5 \text{ dBm} = 17.8\text{W}$

Attenuation =  $43 + 10\text{Log}_{10}(17.8\text{W})$  or 70 dB whichever is less stringent

Attenuation = 55.5 dB or 70 dB whichever is less stringent

Attenuation = 55.5 dB

**Test result:**

$\Delta P \text{ to IMD} = 42.5 \text{ dBm} - (-15.55 \text{ dBm}) = 58.05 \text{ dB}$

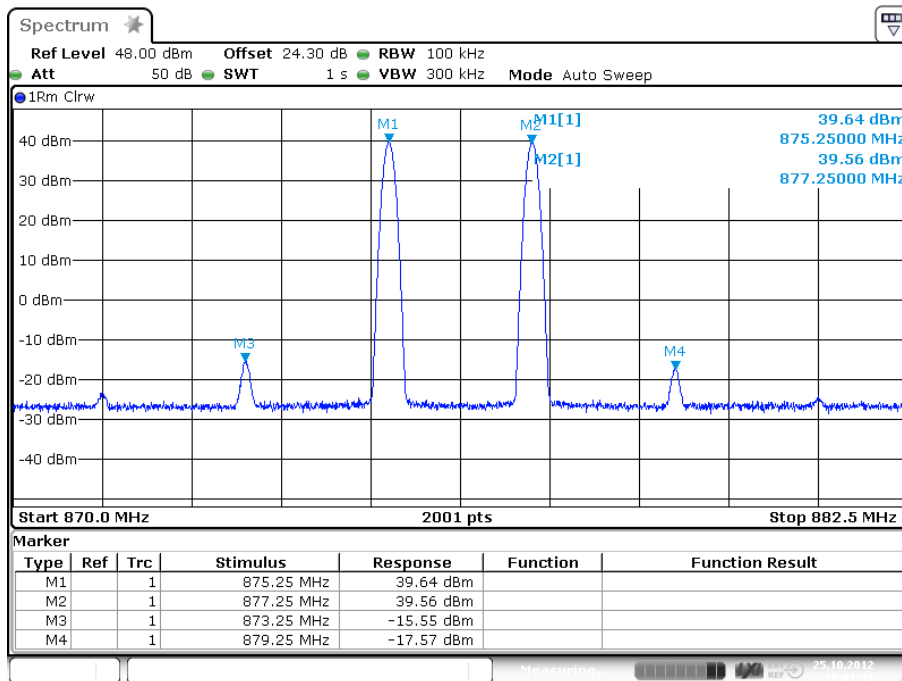

Date: 25.OCT.2012 18:01:12

plot 10.3.1-#1 Non-Linearity: IC RSS-131; Test results; Downlink

#### 10.3.2 Uplink

n.a.

Note: The EUT does not transmit over the air in the uplink direction.

### 10.4 Summary test result

Test result	complies, according to the plots above
Tested by:	M. Leinfelder
Date:	25.10.2012



## 11 Spurious Emissions: RSS-131

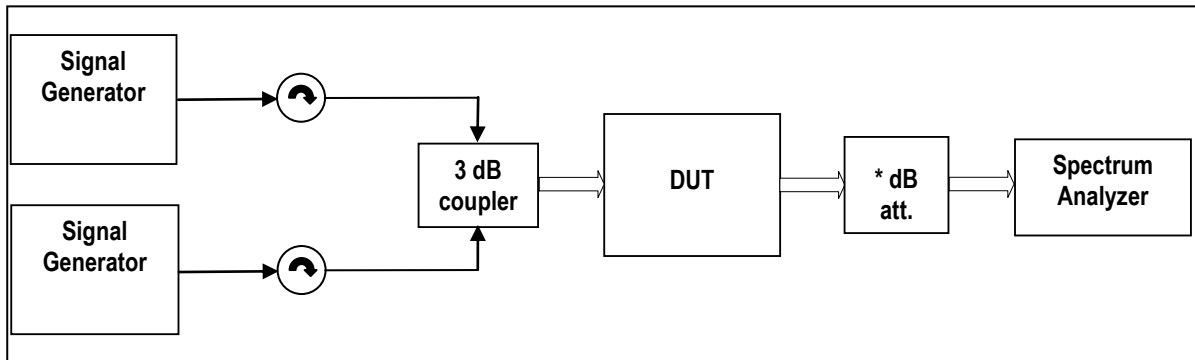

External Attenuator DL x dB = 20 dB  
figure 11-#1 Test setup: **Spurious Emissions: RSS-131**

Measurement uncertainty	± 0,54 dB ± 1,2 dB ± 1,5 dB	9 kHz to 3 GHz 3 GHz to 7 GHz 7 GHz to 13,6 GHz
Test equipment used	9054, 9046, 9123, 7336, 7119, 7409, 7449, 7443, 7444,	

### 11.1 Limit

RSS-131 clause 6.4

Spurious emissions of zone enhancers and translators shall be suppressed as much as possible.

Spurious emissions shall be attenuated below the rated power of the enhancer by at least:

$43 + 10 \log_{10}(P)$  (P rated in watts), or 70 dB, whichever is less stringent.

### 11.2 Test method

RSS-131 clause 4.4.1

The spurious emissions of the equipment under test shall be measured using the two-tone method in section 4.3.1, with the two tones  $P_{01}$  and  $P_{02}$  set to the required levels.

Using a spectrum analyser with a resolution bandwidth set at 100 kHz, search for spurious emissions from 30 MHz to at least 5 times the highest RF pass band frequency. The search may omit the band that contains the test tones and intermodulation products.

### 11.3 Test results

#### 11.3.1 Downlink

Requirement calculation:

$P = 42.5 \text{ dBm} = 17.8 \text{ W}$

Attenuation =  $43 + 10 \log_{10}(17.8 \text{ W})$  or 70 dB whichever is less stringent

Attenuation = 55.5 dB or 70 dB whichever is less stringent

Attenuation = 55.5 dB

Test result:



Delta P to IMD = 42.5 dBm – (-15.55 dBm) = 58.05 dB

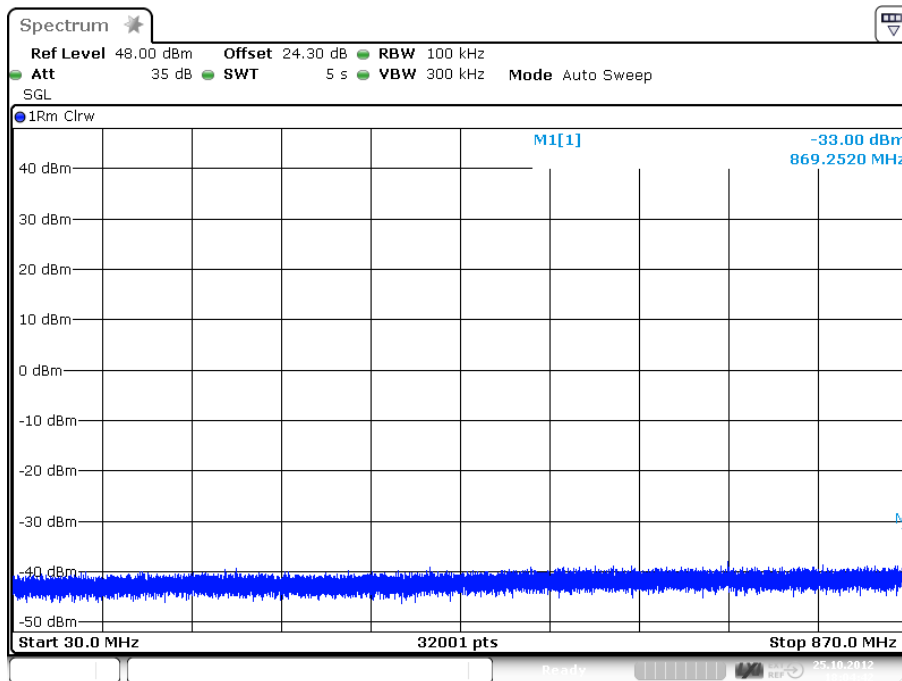

Date: 25.OCT.2012 18:04:42

plot 11.3.1-#1 Spurious Emissions: RSS-131; Test results; Downlink; 30 MHz – 869 MHz

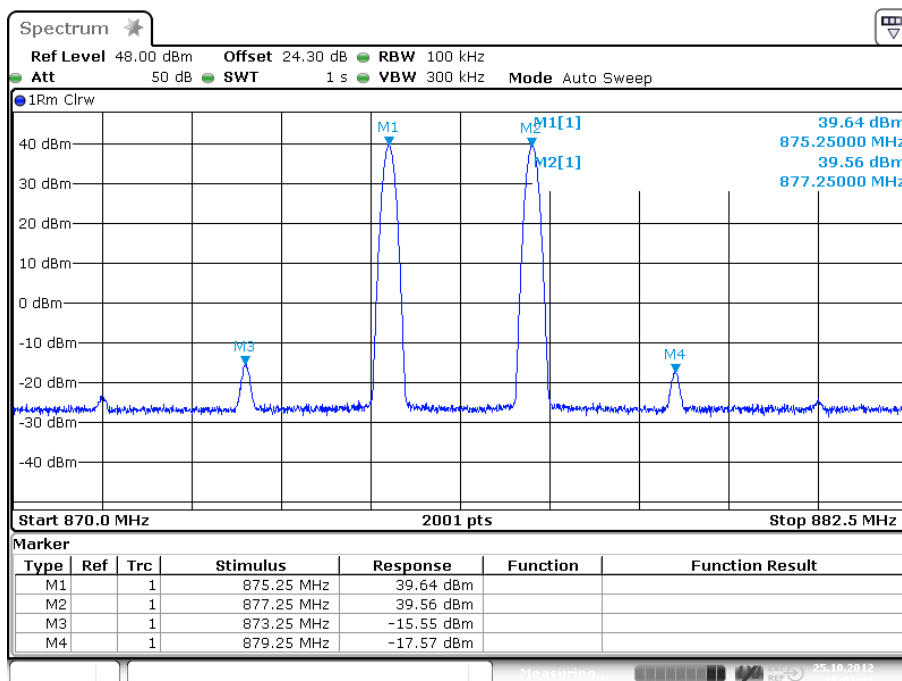

Date: 25.OCT.2012 18:01:12

plot 11.3.1-#2 Spurious Emissions: RSS-131; Test results; Downlink; 869 MHz – 894 MHz

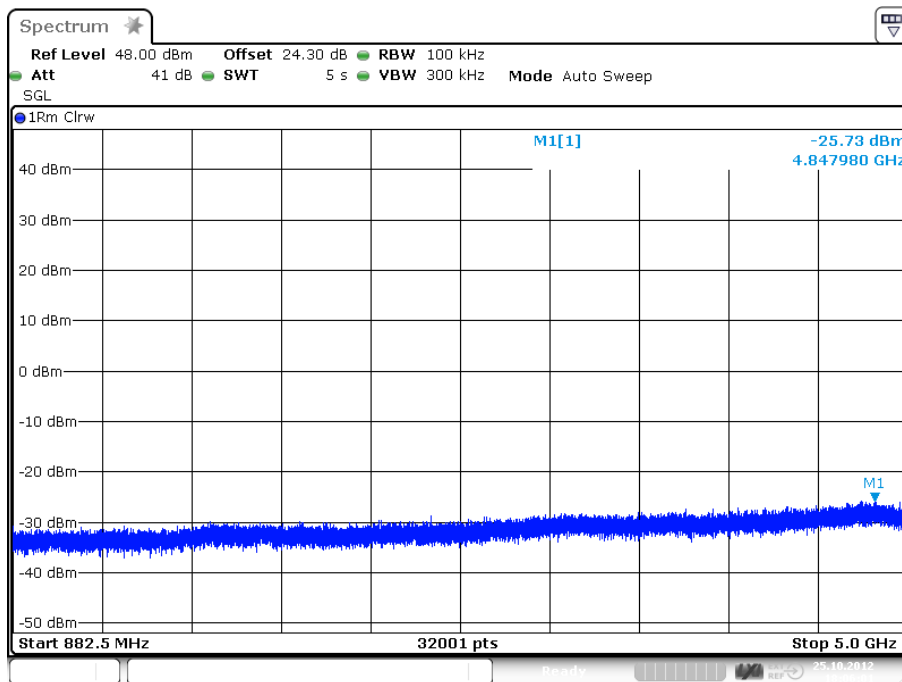

Date: 25.OCT.2012 18:06:02

plot 11.3.1-#3 Spurious Emissions: RSS-131; Test results; Downlink; 894 MHz – 5 GHz

### 11.3.2 Uplink

n.a.

Note: The EUT does not transmit over the air in the uplink direction.

### 11.4 Summary test result

Test result	complies, according the plots above
Tested by:	M. Leinfelder
Date:	25.10.2012

Test Report No.: 12-227

FCC ID: XS5-M85PR

IC ID: 2237E- M85PR



**BUREAU  
VERITAS**

## 12 Field Strength of Spurious Emissions: §22.917, §2.1053

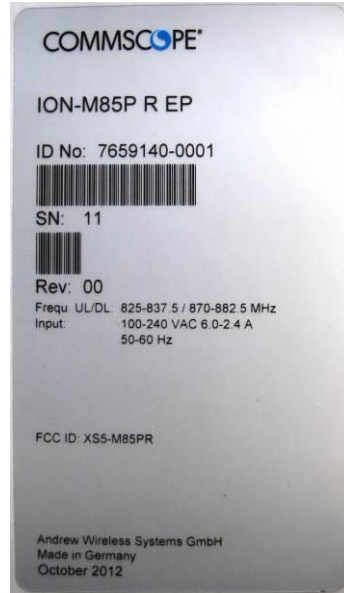

picture 8.1: label

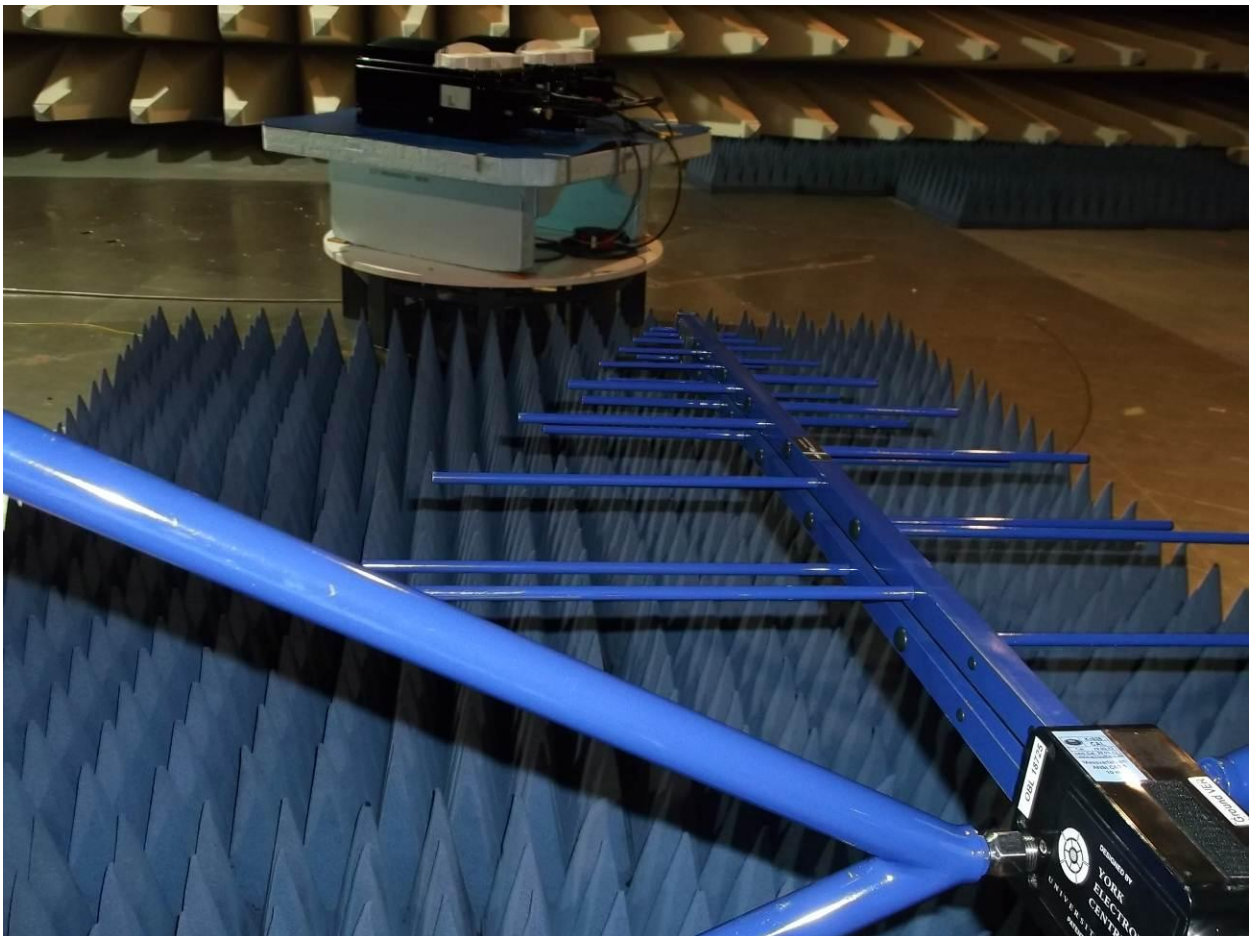

picture 8.2: Test setup: Field Strength Emission <1 GHz @3m in the SAC



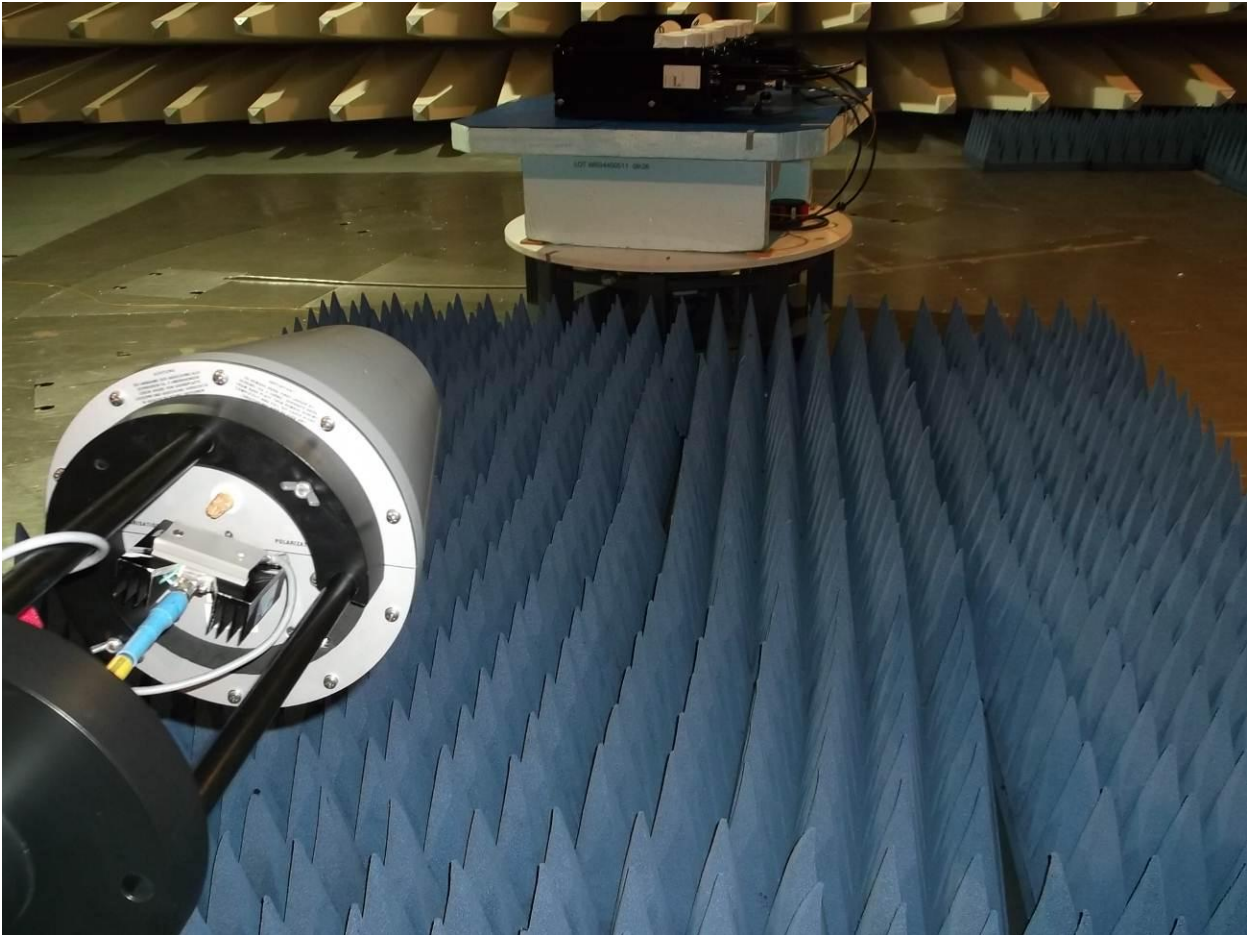

picture 8.3: Test setup: Field Strength Emission >1 GHz @3m in the SAC



Test Report No.: 12-227

FCC ID: XS5-M85PR

IC ID: 2237E- M85PR



**BUREAU  
VERITAS**

This clause specifies requirements for the measurement of radiated emission.

Frequency range	Distance: EUT <-> antenna / location	Limit	Test method
30 MHz - 18 GHz	3 metres / SAC	FCC 47 CFR Part 22.917	TIA/EIA-603-C:2004
		IC RSS-131	
		FCC 47 CFR Part 22.917	
		IC RSS-131	

**Test equipment used:**

Designation	Type	Manufacturer	Invent.-no.	Cal.-date	due Cal.- date	used
EMI test receiver	ESI40	Rohde & Schwarz	E1687	22.12.2011	22.12.2012	X
Antenna	CBL 6111	Chase	K1149	10.05.2012	10.05.2013	X
Antenna	HL 025	R&S	K809	16.11.2012	16.11.2013	X
Preamplifier	AFS4-00102000	Miteq	K838	05.06.2012	05.06.2013	X
RF Cable	Sucoflex 100	Suhner	K1742	23.05.2012	23.05.2013	X

The REMI version 2.135 has been used for max search.

**Test set-up:**

Test location: SAC/FAC  
Both, the Fully Anechoic Chamber (FAC) and the Semi Anechoic Chamber (SAC) fulfil the requirements of ANSI C63.4 and CISPR 16-1-4 with regards to NSA and SVSWR.

Test Voltage: 115V / 60 Hz  
Type of EUT: Wall mounted

**Measurement uncertainty:**

Measurement uncertainty expanded (95% or K=2)	$\pm 4,7$ dB for ANSI C63.4 measurement $\pm 0,5$ dB for TIA-603 measurement
--	---

Test Report No.: 12-227

FCC ID: XS5-M85PR

IC ID: 2237E- M85PR



BUREAU  
VERITAS

## 12.1 Limit §22.917

The rules in this section govern the spectral characteristics of emissions in the Broadband Personal Communications Service.

(a) *Out of band emissions.* The power of any emission outside of the authorized operating frequency ranges must be attenuated below the transmitting power (P) by a factor of at least  $43 + 10 \log(P)$  dB.

(b) *Measurement procedure.* Compliance with these rules is based on the use of measurement instrumentation employing a resolution bandwidth of 1 MHz or greater. However, in the 1 MHz bands immediately outside and adjacent to the frequency block a resolution bandwidth of at least one percent of the emission bandwidth of the fundamental emission of the transmitter may be employed. A narrower resolution bandwidth is permitted in all cases to improve measurement accuracy provided the measured power is integrated over the full required measurement bandwidth ( *i.e.* 1 MHz or 1 percent of emission bandwidth, as specified). The emission bandwidth is defined as the width of the signal between two points, one below the carrier center frequency and one above the carrier center frequency, outside of which all emissions are attenuated at least 26 dB below the transmitter power.

The emission measurements have been made with transmission at **Bottom/Middle/Top** frequency (**870MHz / 876.25MHz / 882.5MHz**)

The limit is -13dBm (e.i.r.p).

## 12.2 Test method ANSI/TIA/EA-603-C

### Measurement procedure. TIA-603-C

The antenna substitution method is used to determine the equivalent radiated power at spurious frequencies. The spurious emissions are measured at a distance of 3 meters. The EUT is then replaced with a reference substitution antenna with a known gain referenced to a dipole. This antenna is fed with a signal at the spurious frequency. The level of the signal is adjusted to repeat the previously measured level. The resulting eirp is the signal level fed to the reference antenna corrected for gain referenced to an isotropic dipole (see Figure 7.2).

From KDB (AMPLIFIER, BOOSTER, AND REPEATER REMINDER SHEET):

Radiated spurs (enclosure) – Use of CW signal (low, mid, and high freq.) is acceptable rather than all modulations.

The maximum RFI field strength was determined during the measurement by rotating the turntable ( $\pm 180$  degrees) and varying the height of the receive antenna ( $h = 1 \dots 4$  m) as like defined in ANSI C63.4. A measurement receiver has been used with a RBW 120 kHz up to 1 GHz and 1 MHz above 1 GHz. Steps with during pre measurement was half the RBW.

Both, the Fully Anechoic Chamber (FAC) and the Semi Anechoic Chamber (SAC) fulfil the requirements of ANSI C63.4 and CISPR 16-1-4 with regards to NSA and SVSWR.

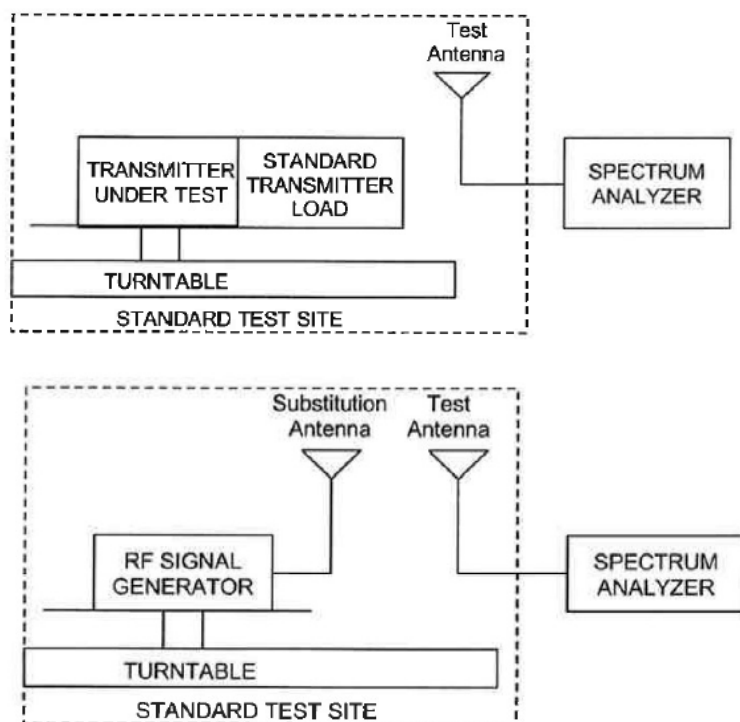

picture 8.3: Substitution method

## 12.3 Climatic values in the lab

Temperature: 22°  
 Relative Humidity: 43%  
 Air-pressure: 1009hPa



## 12.4 Test results

### 12.4.1 30 MHz to 1 GHz Downlink (Bottom – Middle – Top)

B/M/T: 870MHz / 876.25MHz/ 882.5MHz

Polarisation: horizontal, vertical

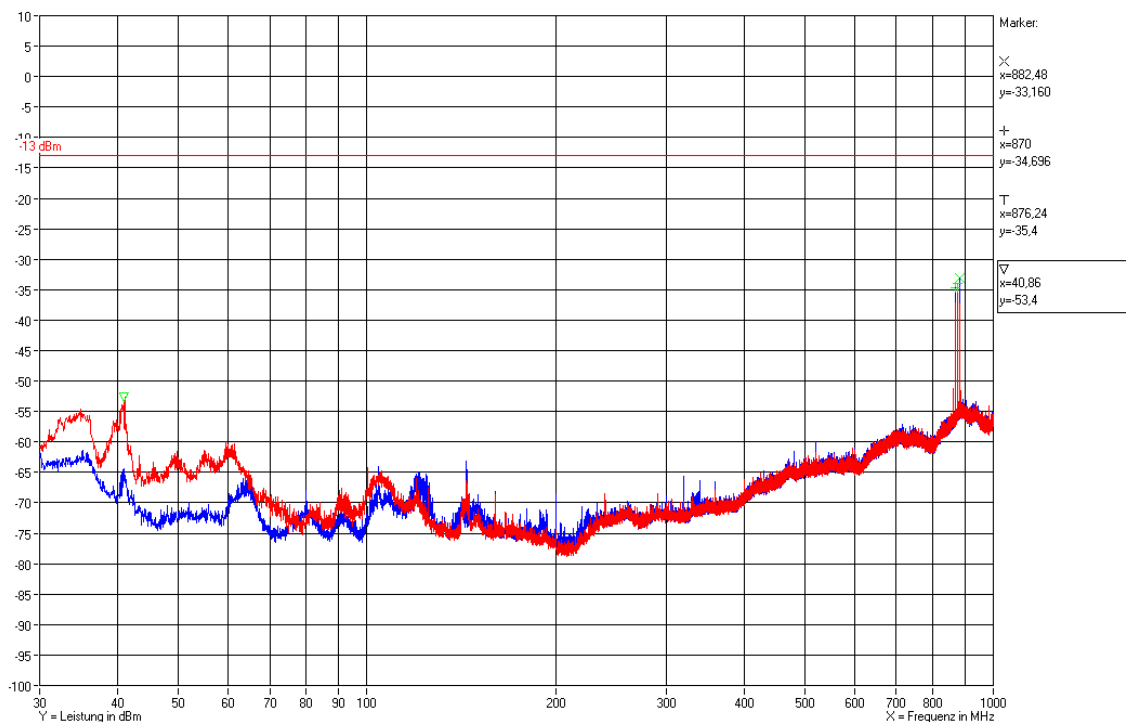

Plot 12.1: Measurement: Field Strength Emission <1 GHz @3m in the SAC max.hold

Test Report No.: 12-227

FCC ID: XS5-M85PR

IC ID: 2237E- M85PR



BUREAU  
VERITAS

### 12.4.2 1 GHz to 18 GHz Downlink

B/M/T: 870MHz / 876.25MHz/ 882.5MHz

Polarisation: horizontal, vertical

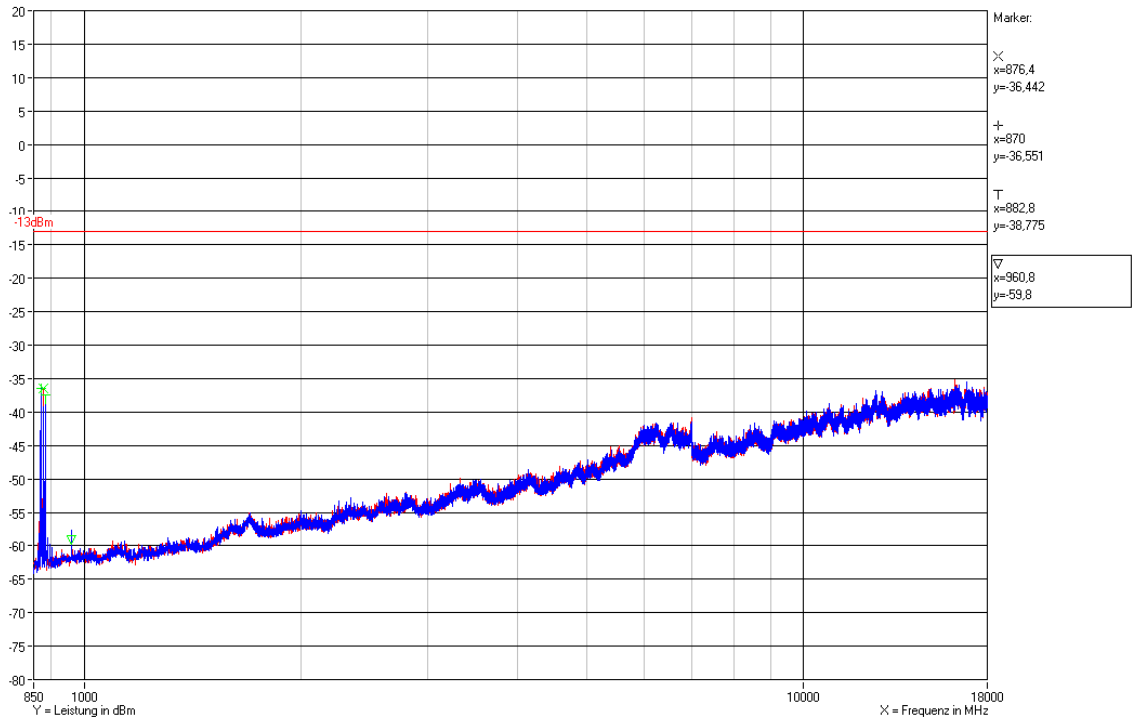

Plot 12.2: Measurement: Field Strength Emission <1 GHz @3m in the SAC max.hold

Test Report No.: 12-227

FCC ID: XS5-M85PR

IC ID: 2237E- M85PR



**BUREAU  
VERITAS**

### 12.5 Summary test result

Test result	complies, according to the plots above
Tested by:	Tom Zahlmann
Date:	27.12.2012

### 13 History

Revision	Modification	Date	Name
V01.00	Initial	04.12.2012	Tom Zahlmann

**\*\*\*\*\* End of test report \*\*\*\*\***