

Test Site:
FCC Test Site No.: 96997
IC OATS No.: IC3475A-1



BUREAU
VERITAS

ECL-EMC Test Report No.: 13-238

Equipment under test: ION-M7P/17HP 700MHz Path
FCC ID: XS5-M7P17HP
IC ID: 2237E-M7P17HP
Type of test: FCC 47 CFR Part 27 Subpart H, F: 2013
Miscellaneous Wireless Communication Services
IC RSS-131:2003
Zone Enhancers for the Land Mobile Service

Measurement Procedures: 47 CFR Parts 2: 2013 (*Frequency Allocations and Radio Treaty Matters; General Rules and Regulations*),
Part 27: 2013 (*Miscellaneous Wireless Communication Services*),
ANSI/TIA-603-C:2004, *Land Mobile FM or PM Communications Equipment Measurement and Performance Standards*
IC RSS-GEN:2010 General Requirements and Information for the Certification of Radiocommunication Equipment

Test result: **Passed**

Date of issue:	04.09.13		Signature:
Issue-No.:	01	Author:	
Date of delivery:		Checked:	
Test dates:	05.09.11 – 03.09.13		
Pages:	48		

Test Report No.: 13-238

FCC ID: XS5-M7P17HP

IC ID: 2237E-M7P17HP



BUREAU
VERITAS

Manufacturer: ANDREW Wireless Systems GmbH
Industriering 10

D-86675 Buchdorf

Tel.: +49 (0)9099 69 0

Fax: +49 (0)9099 69 140

Test house: Bureau Veritas Consumer Products Services

Germany GmbH

European Compliance Laboratory (ECL)

Thurn-und-Taxis-Straße 18

D-90411 Nürnberg

Tel.: +49 40 74041 0

Fax: +49 40 74041-2755

General:

The purpose of this report is to show compliance to the FCC regulations for devices operating under Part 27 of the Code of Federal Regulations title 47.

This report informs about the results of the EMC tests, it only refers to the equipment under test. No part of this report may be reproduced in any form, without written permission.



Table of contents

1	TEST RESULTS SUMMARY	6
2	EQUIPMENT UNDER TEST (E.U.T.)	7
2.1	DESCRIPTION	7
2.1.1	DOWNLINK	7
2.1.2	UPLINK	7
2.1.3	DESCRIPTION OF EUT	7
2.1.4	BLOCK DIAGRAM OF MEASUREMENT REFERENCE POINTS	8
2.1.5	DOWNLINK SYSTEM GAIN AND OUTPUT POWER	8
3	TEST SITE (ANDREW BUCHDORF)	9
3.1	TEST ENVIRONMENT	9
3.2	TEST EQUIPMENT	10
3.3	INPUT AND OUTPUT LOSSES	11
3.4	MEASUREMENT UNCERTAINTY	11
4	TEST SITE (BUREAU VERITAS CPS)	11
5	RF POWER OUT: §27.50, §2.1046	12
5.1	LIMIT	12
5.2	TEST METHOD	12
5.3	TEST RESULTS	13
5.3.1	DOWNLINK	13
5.3.1.1	LTE 728 – 746MHz	14
5.3.1.2	LTE 746 – 757MHz	14
5.3.2	UPLINK	15
5.4	SUMMARY TEST RESULT	15
6	OCCUPIED BANDWIDTH: §90.210, §2.1049	16
6.1	LIMIT	16
6.2	TEST METHOD	16
6.3	TEST RESULTS	16
6.3.1	DOWNLINK	16
6.3.1.1	LTE 728 – 746MHz	17
6.3.1.2	LTE 746 – 757MHz	18
6.3.2	UPLINK	19
6.4	SUMMARY TEST RESULT	19
7	SPURIOUS EMISSIONS AT ANTENNA TERMINALS: §27.53, §2.1051	20
7.1	LIMIT	20
7.2	TEST METHOD	21
7.3	TEST RESULTS	21
7.3.1	DOWNLINK	21
7.3.1.1	LTE < 1MHz to band edge; 728 – 746MHz	23
7.3.1.2	LTE < 1MHz to band edge 746 – 757MHz	24
7.3.1.3	LTE > 1MHz to band edge 728 – 746MHz	25



7.3.1.4	LTE > 1MHz to band edge 746 – 757MHz; carrier at 751,5MHz	25
7.3.1.5	Measurement in the band of 1559 MHz – 1610 MHz acc. to 27.53(f).....	26
7.3.2	UPLINK	26
7.4	SUMMARY TEST RESULT	26
8	AMPLIFIER GAIN AND BANDWIDTH: IC RSS-131	27
8.1	LIMIT	27
8.2	TEST METHOD	27
8.3	TEST RESULTS	27
8.3.1	DOWNLINK	27
8.3.2	UPLINK	28
8.4	SUMMARY TEST RESULT	28
9	OUTPUT POWER: IC RSS-131	29
9.1	LIMIT	29
9.2	TEST METHOD	29
9.3	TEST RESULTS	30
9.3.1	DOWNLINK	30
9.3.2	UPLINK	30
9.4	SUMMARY TEST RESULT	31
10	NON-LINEARITY: IC RSS-131	32
10.1	LIMIT	32
10.2	TEST METHOD.....	32
10.3	TEST RESULTS.....	33
10.3.1	DOWNLINK	33
10.3.2	UPLINK	33
10.4	SUMMARY TEST RESULT	33
11	SPURIOUS EMISSIONS: RSS-131	34
11.1	LIMIT	34
11.2	TEST METHOD.....	34
11.3	TEST RESULTS.....	34
11.3.1	DOWNLINK	34
11.3.2	UPLINK	36
11.4	SUMMARY TEST RESULT	36
12	RADIATED SPURIOUS EMISSIONS AT THE ECL (BV): §27.53, §2.1053, RSS-GEN, RSS-131	37
12.1	METHOD OF MEASUREMENT	40
12.2	LIMIT	41
12.3	RECEIVER SETTINGS.....	41
12.4	CLIMATIC VALUES IN THE LAB.....	41
12.5	TEST RESULTS.....	42
12.5.1	30 MHz TO 1 GHz DOWNLINK (BOTTOM – MIDDLE – TOP) SUBPART H.....	42
12.5.2	30 MHz TO 1 GHz DOWNLINK (BOTTOM – MIDDLE – TOP) SUBPART F	43
12.5.3	30 MHz TO 1 GHz DOWNLINK (MIDDLE OF ALL PATHS)	44
12.5.4	1 GHz TO 22 GHz DOWNLINK (BOTTOM – MIDDLE – TOP) SUBPART H.....	45

Test Report No.: 13-238

FCC ID: XS5-M7P17HP

IC ID: 2237E-M7P17HP



BUREAU
VERITAS

12.5.5	1 GHZ TO 22 GHZ DOWNLINK (BOTTOM – MIDDLE – TOP) SUBPART F	46
12.5.6	1 GHZ TO 22 GHZ DOWNLINK (MIDDLE OF ALL PATHS)	47
13	HISTORY	48



1 Test Results Summary

Name of Test	FCC Para. No.	FCC Method	FCC Spec.	Result
RF Power Output	27.50(b)(c)	2.1046	1000 Watts ERP	Complies
Occupied Bandwidth	2.1049	2.1049	Input/Output	Complies
Spurious Emissions at Antenna Terminals	27.53(c)(d)(g)	2.1051	-13dBm	Complies
Radiated Spurious emission	27.53(m)	2.1053 TIA/EA-603	-13dBm E.I.R.P	Complies
Frequency Stability	27.54	2.1055	Must stay in band	NA

Name of Test	IC Para. No.	IC Method	Result
RF Power Output	RSS-131	RSS-GEN 4.8	Complies
Occupied Bandwidth	RSS-131	RSS-GEN 4.6.1	Complies
Spurious Emissions at Antenna Terminals	RSS-131	RSS-GEN 4.9	Complies
Field Strength of Spurious Emissions	RSS-131 6.4	RSS-GEN 4.9	Complies
Frequency Stability	RSS-131	RSS-GEN 4.7	NA

Frequency stability is given by: The system gets an electrical analog signal from the BSS which is converted into an analog optical signal, transmitted by the optical links and then reconverted in the Remote Unit into an analog electrical signal. During this process happens no frequency change/modification, so input and output have same frequency what can be seen under clause "Occupied Bandwidth".



2 Equipment under test (E.U.T.)

2.1 Description

Kind of equipment	ION-M7P/17HP
Andrew Ident. Number	Id.No. 7679145-0001
Serial no.(SN)	11
Revision	00
Software version and ID	n. a.
Type of modulation and Designator	LTE (G7D) <input checked="" type="checkbox"/>
Frequency Translation	F1-F1 <input checked="" type="checkbox"/>
	F1-F2 <input type="checkbox"/>
	N/A <input type="checkbox"/>
Band Selection	Software <input type="checkbox"/>
	Duplexer <input checked="" type="checkbox"/>
	Full band <input type="checkbox"/>

2.1.1 Downlink

Pass band	Path 728 MHz – 757 MHz
Nominal 20dB bandwidth	37.9 MHz
Max. composite output power based on one carrier per path (rated)	43 dBm = 20 W
System Gain*	10 dB @ Pout BTS of 33 dBm

*see 2.1.4 Block diagram of measurement reference points

2.1.2 Uplink

Pass band	n. a.
System Gain*	n. a.

*see 2.1.4 Block diagram of measurement reference points

Note: The EUT does not transmit over the air in the uplink direction.

2.1.3 Description of EUT

ION-M7P/17HP is a multi-band, multi-operator Remote Unit with various Extension Units. It is used in conjunction with a Master Unit in the ION optical distribution system. This system transports up to two frequency bands simultaneously (700 MHz, 1700/2100 MHz), providing a cost-effective solution for distributing capacity from one or more base stations.

The ION- M7P/17HP Repeater consists of one 700 MHz path and one 1700/2100 MHz path, with the intended use of simultaneous transmission

This Test Report describes the approval of the ION-M7P (LTE 700 MHz).



2.1.4 Block diagram of measurement reference points

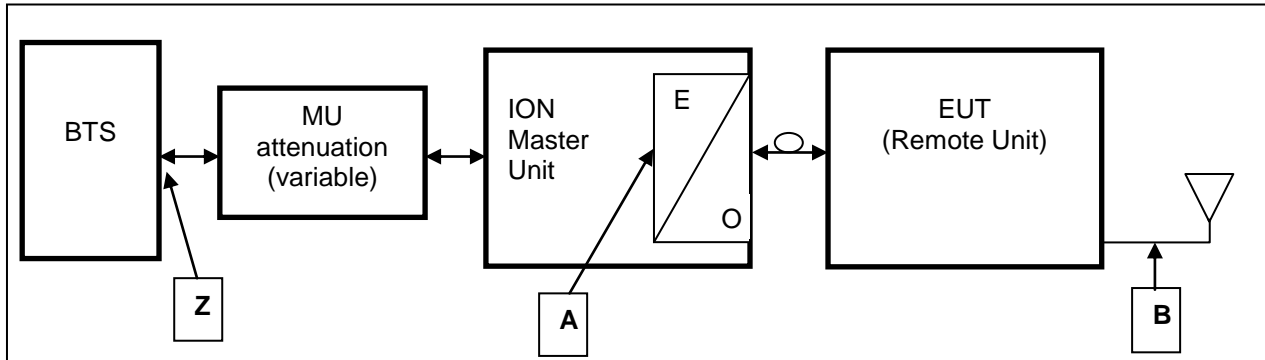

figure 2.1.4-#1 Block diagram of measurement reference points

Remote Unit is the EUT

O/E Optical / Electrical converter
 SRMU Sub Rack Master Unit

Reference point A SRMU UL output, DL input
 Reference point B Remote Unit DL output, UL input
 Reference point Z BTS DL output, UL input

Since a signal generator does not supply a good output signal with +33 or +43dBm, for the downlink measurement the MU Attenuation is not used.

That means for downlink measurements the signal generator is connected to measurement point A at the master optical / electrical converter and the analyzer to the measurement point B at the RU.

2.1.5 Downlink System Gain and Output Power

System optimized for BTS power (fixed value) Z	MU Attenuation (manual leveling)	Maximum rated input power at the MU OTRX (fixed value) A	RU Gain (fixed value) A to B	Maximum rated output power at RU Antenna port (fixed value) B
+33 dBm	30 dB	3 dBm	+40 dB	+43 dBm @ 1 carrier
System Gain Z to A	+10 dB			
+43 dBm	40 dB	3 dBm	+40 dB	+43 dBm @ 1 carrier
System Gain Z to A	+0 dB			

table 2.1.5-#1 Equipment under test (E.U.T.) Description Downlink System Gain and Output Power

Test Report No.: 13-238

FCC ID: XS5-M7P17HP

IC ID: 2237E-M7P17HP



**BUREAU
VERITAS**

3 Test site (Andrew Buchdorf)

3.1 Test environment

All tests were performed under the following environmental conditions:

Condition	Minimum value	Maximum value
Barometric pressure	86 kPa	106 kPa
Temperature	15°C	30°C
Relative Humidity	20 %	75 %
Power supply range	±5% of rated voltages	



3.2 Test equipment

ANDREW Inv. No.	Test equipment	Type	Manufacturer	Serial No.	Calibration
9102	Network Analyzer	ZVB 14	R&S	100118	08/12
9054	Spectrum Analyzer	FSV13	R&S	100859	12/11
8736	Spectrum Analyzer	FSIQ-26	R&S	100290	12/11
9052	Signal Generator	SMBV100A	R&S	255089	01/12
8990	Signal Generator	SMJ100A	R&S	101288	07/12
8671	Power Meter	E4418B	Agilent	GB39513094	06/12
8672	Power Sensor	E9300H	Agilent	US41090179	06/12
7280	Power Attenuator	768-30	Narda	---	CIU
7119	Divider	2way	Mikom	3512	CIU
7408	RF-Cable	2,0m; N-N	Andrew	---	CIU
7409	RF-Cable	2,0m; N-N	Andrew	---	CIU
7410	RF-Cable	1,0m; N-N	Andrew	---	CIU
7411	RF-Cable	2,0m; N-N	Andrew	---	CIU
7364	RF-Cable	1,0m; SMA	Huber & Suhner	36309/4P	CIU
7365	RF-Cable	1,0m; SMA	Huber & Suhner	36292/4P	CIU
7366	RF-Cable	2,0m; SMA	Huber & Suhner	36183/4P	CIU
7367	RF-Cable	2,0m; SMA	Huber & Suhner	36158/4P	CIU
7373	RF-Cable	Multiflex141 0,6m	Andrew	---	CIU
7374	RF-Cable	Multiflex141 0,6m	Andrew	---	CIU

CIU = Calibrate in use

Andrew Inv. No.	Test equipment	Type	Manufacturer	Serial No.	Calibration
8741	Network Analyzer	ZVRE	R&S	100034	02/2013
8961	Spectrum Analyzer	FSP	R&S		07/2012
9126	Spectrum Analyzer	FSV30	R&S	101237	11/2012
9069	Generator	SMBV100A	Agilent		08/2012
9123	Generator	SMBV100A	R&S		11/2012
8375	Universal Counter	53132A	Agilent		07/2012
8667	Power Meter	E4418A	Agilent	GB38273230	04/2013
8668	Power Sensor	E8481H	Agilent	US3318A19208	04/2013
7157	RF-Cable	Succoflex	Suhner	36180/4P	CIU
7158	RF-Cable	Succoflex	Suhner	36182/4P	CIU
7289	RF-Cable	Succoflex	Suhner	28443/4PE	CIU
7290	RF-Cable	Succoflex	Suhner	28444/4PE	CIU
7385	RF-Cable	Succoflex	Suhner	36267/4P	CIU
7387	RF-Cable	Succoflex	Suhner	36267/4P	CIU
7390	RF-Cable	Succoflex	Suhner	40193/4P	CIU
7381	RF-Cable	Succoflex	Suhner	40200/4P	CIU
7384	RF-Cable	Succoflex	Suhner	40448/4P	CIU
7294	RF-Cable	Succoflex	Suhner	40448/4P	CIU
7382	RF-Cable	Succoflex	Suhner	40221/4P	CIU
7160	Divider	SMP 317	Mikom	784	CIU

CIU = Calibrate in use

Test Report No.: 13-238

FCC ID: XS5-M7P17HP

IC ID: 2237E-M7P17HP



**BUREAU
VERITAS**

3.3 Input and output losses

All recorded power levels should be referenced to the input and output connectors of the repeater, unless explicitly stated otherwise.

The test equipment used in this test has to be calibrated, so that the functionality is also checked.

All cables, attenuators, splitter, isolator, circulator and combiner etc. must be measured before testing and used for compensation during testing.

3.4 Measurement uncertainty

The extended measurement uncertainty corresponds to the measurement results from the standard measurement uncertainty multiplied by the coverage factor $k=2$. The true value is located in the corresponding interval with a probability of 95 %.

4 Test site (Bureau Veritas CPS)

FCC Test site: **96997**

IC OATS: **IC3475A-1**

See relevant dates under section 8 of this test report.

5 RF Power Out: §27.50, §2.1046

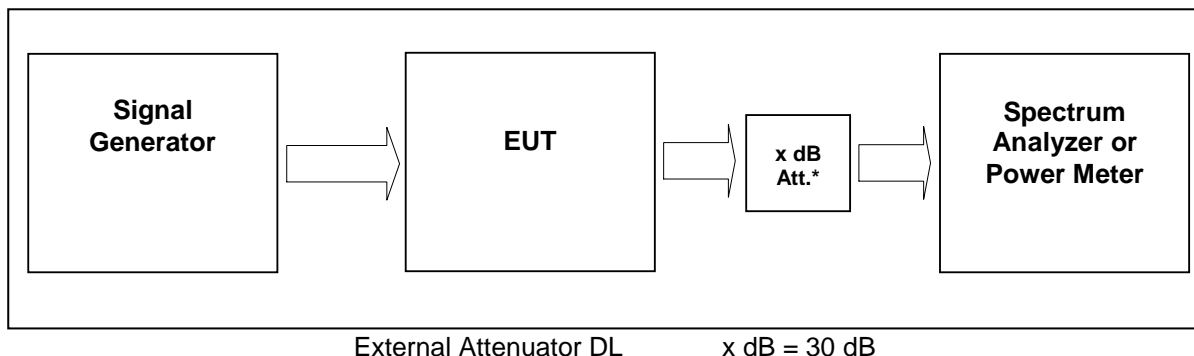

figure 5-#1 Test setup: RF Power Out: §27.50, §2.1046

Measurement uncertainty	± 0,38 dB
Test equipment used	9054, 9052, 7399, 7400, 7409, 7410, 7280

5.1 Limit

Minimum standard:

Para. No.27.50(b)(4) and (c)(1) and (c) (3)

(b) The following power and antenna height limits apply to transmitters operating in the 746–763 MHz, 775–793 MHz and 805–806 MHz bands:

(4) Fixed and base stations transmitting a signal in the 746–757 MHz, 758–763 MHz, 776–787 MHz, and 788–793 MHz bands with an emission bandwidth greater than 1 MHz must not exceed an ERP of 1000 watts/MHz and an antenna height of 305 m HAAT, except that antenna heights greater than 305 m HAAT are permitted if power levels are reduced below 1000 watts/MHz ERP accordance with Table 3 of this section.

(c) The following power and antenna height requirements apply to stations transmitting in the 698–746 MHz band:

(1) Fixed and base stations transmitting a signal with an emission bandwidth of 1 MHz or less must not exceed an effective radiated power (ERP) of 1000 watts and an antenna height of 305 m height above average terrain (HAAT), except that antenna heights greater than 305 m HAAT are permitted if power levels are reduced below 1000 watts ERP in accordance with Table 1 of this section;

(3) Fixed and base stations transmitting a signal with an emission bandwidth greater than 1 MHz must not exceed an ERP of 1000 watts/MHz and an antenna height of 305 m HAAT, except that antenna heights greater than 305 m HAAT are permitted if power levels are reduced below 1000 watts/MHz ERP in accordance with Table 3 of this section;

5.2 Test method

§ 2.1046 Measurements required: RF power output.

(a) For transmitters other than single sideband, independent sideband and controlled carrier radiotelephone, power output shall be measured at the RF output terminals when the transmitter is adjusted in accordance with the tune-up procedure to give the values of current and voltage on the circuit elements specified in § 2.1033(c)(8). The electrical characteristics of the radio frequency load attached to the output terminals when this test is made shall be stated.



(c) For measurements conducted pursuant to paragraphs (a) and (b) of this section, all calculations and methods used by the applicant for determining carrier power or peak envelope power, as appropriate, on the basis of measured power in the radio frequency load attached to the transmitter output terminals shall be shown. Under the test conditions specified, no components of the emission spectrum shall exceed the limits specified in the applicable rule parts as necessary for meeting occupied bandwidth or emission limitations

5.3 Test Results

Detector RMS.

Test signal LTE:

Signal waveform according to Test Model 1.1, E-TM1.1, clause 6.1.1.1-1, table 6.1.1.1-1 of standard specification 3GPP TS 36.141 V9.3.0 (2010-03).

5.3.1 Downlink

Modulation	Measured at	Path	RBW VBW Span	RF Power (dBm)	RF Power (W)	Plot -
LTE	Middle	737 MHz (Band 12 (Band Class 19))	3MHz 10MHz 50MHz	43,0	20	5.3.1.1 #1
LTE	Middle	751,5 MHz (Band 13 (Band Class 7))	3MHz 10MHz 50MHz	43,0	20	5.3.1.2 #1
Maximum output power = 43,0 dBm = 19,953 W						
Limit Maximum output power (erp) = 1000 W						

table 5.3.1-#1 RF Power Out: §27.50, §2.1046 Test Results Downlink

The max RF Power out is 43.0 dBm, so the maximum antenna gain (x) can be calculated as follow:

Limit = 1000W (erp) = 60 dBm

Info: 1000W (erp) = 1640W (eirp)

60 dBm > 43 dBm + x

x < 17 dBd => x < 19.15 dBi

=> The antenna that will be used for the complete system have to have a gain lower than 19.15 dBi, relative to a dipol.

Modulation	Pin / dBm (Ref. point A)
LTE (Band 12 (Band Class 19))	2,8
LTE (Band 13 (Band Class 7))	3.3

table 5.3.1-#2 RF Power Out: §27.50, §2.1046 Test Results Downlink Input power

Test Report No.: 13-238

FCC ID: XS5-M7P17HP

IC ID: 2237E-M7P17HP



5.3.2 Uplink

n.a.

Note: The EUT does not transmit over the air in the uplink direction.

5.4 Summary test result

Test result	complies, according the plots above
Tested by:	M. Leinfelder
Date:	05.09.2011



6 Occupied Bandwidth: §90.210, §2.1049

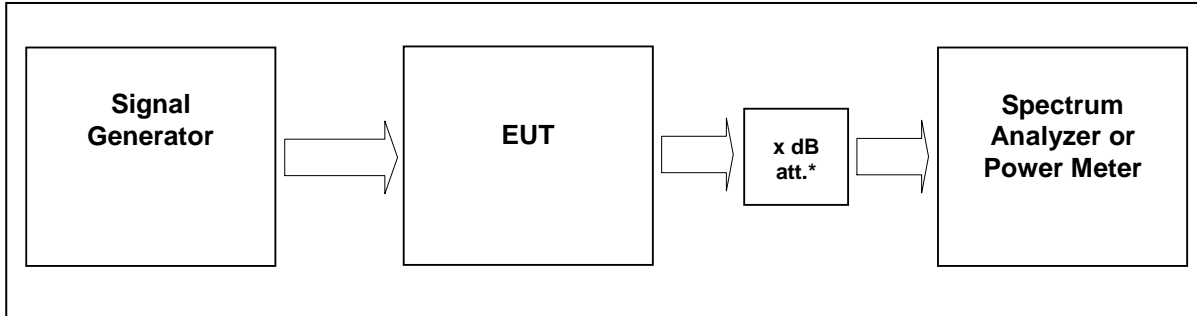

External Attenuator DL x dB = 30 dB
figure 6-#1 Test setup: Occupied Bandwidth: §90.210, §2.1049

Measurement uncertainty	± 0,38 dB
Test equipment used	9054, 9052, 7399, 7400, 7409, 7410, 7280

6.1 Limit

The spectral shape of the output should look similar to input for all modulations.

6.2 Test method

Para. No.2.1049

The occupied bandwidth, that is the frequency bandwidth such that, below its lower and above its upper frequency limits, the mean powers radiated are each equal to 0.5 percent of the total mean power radiated by a given emission shall be measured under the following conditions as applicable:

6.3 Test results

6.3.1 Downlink

Detector RMS.

Modulation	Measured at	Path	RBW VBW Span	Occupied Bandwidth / MHz	Plot #
LTE	Middle	737 MHz Band 12 (Band Class 19)	30 kHz 300 kHz 5 MHz	1.1	6.3.1.1 #1, #2
LTE	Middle	751,5 MHz Band 13 (Band Class 7)	30 kHz 300 kHz 5 MHz	1.1	6.3.1.2 #1, #2

table 6.3-#1 Occupied Bandwidth: §90.210, §2.1049 Test results



6.3.1.1 LTE 728 – 746MHz

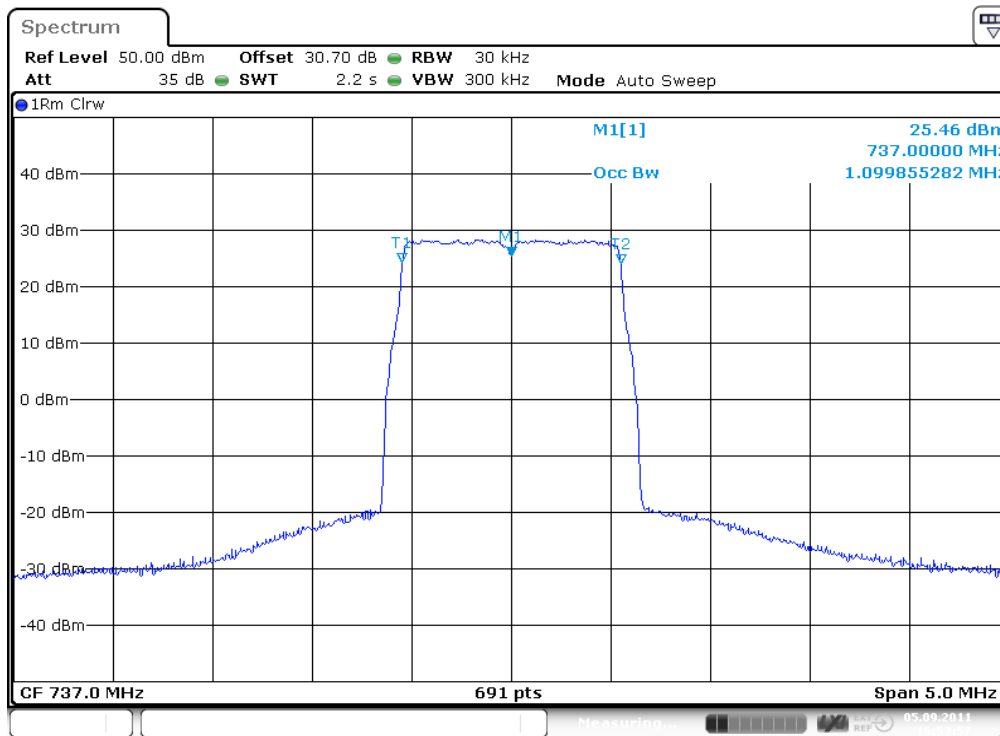

Date: 5.SEP.2011 16:53:58

plot 6.3.1.1-#1 Occupied Bandwidth: §90.210, §2.1049; Test results; Downlink; LTE 728 – 746MHz Output

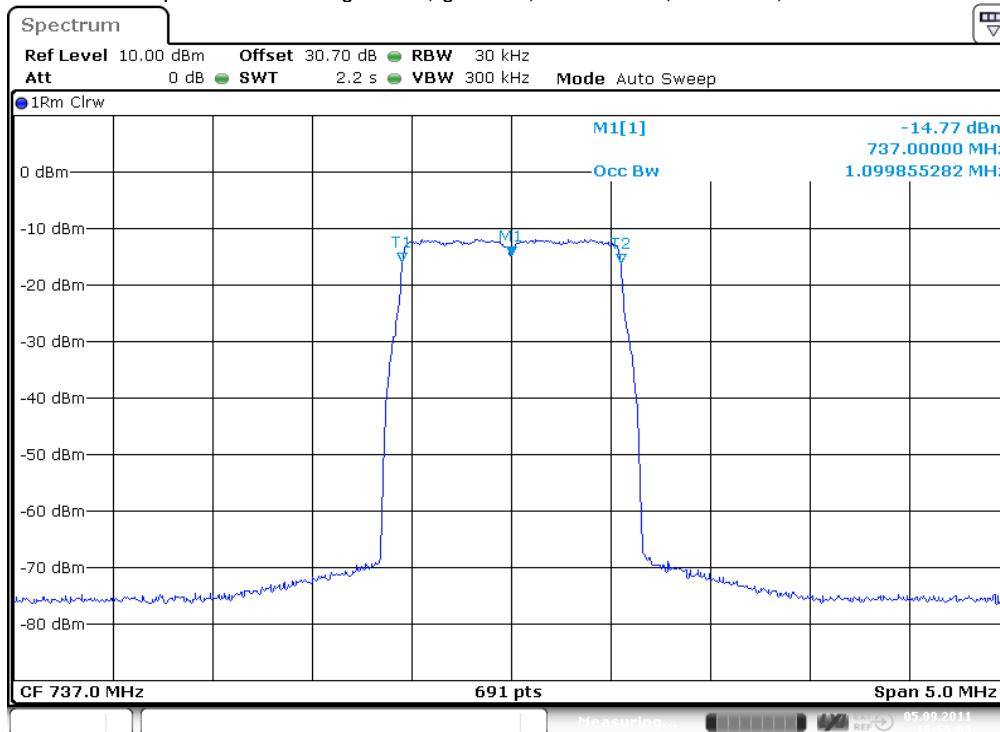

Date: 5.SEP.2011 16:55:09

plot 6.3.1.1-#2 Occupied Bandwidth: §90.210, §2.1049; Test results; Downlink; LTE 728 – 746MHz Input



6.3.1.2 LTE 746 – 757MHz

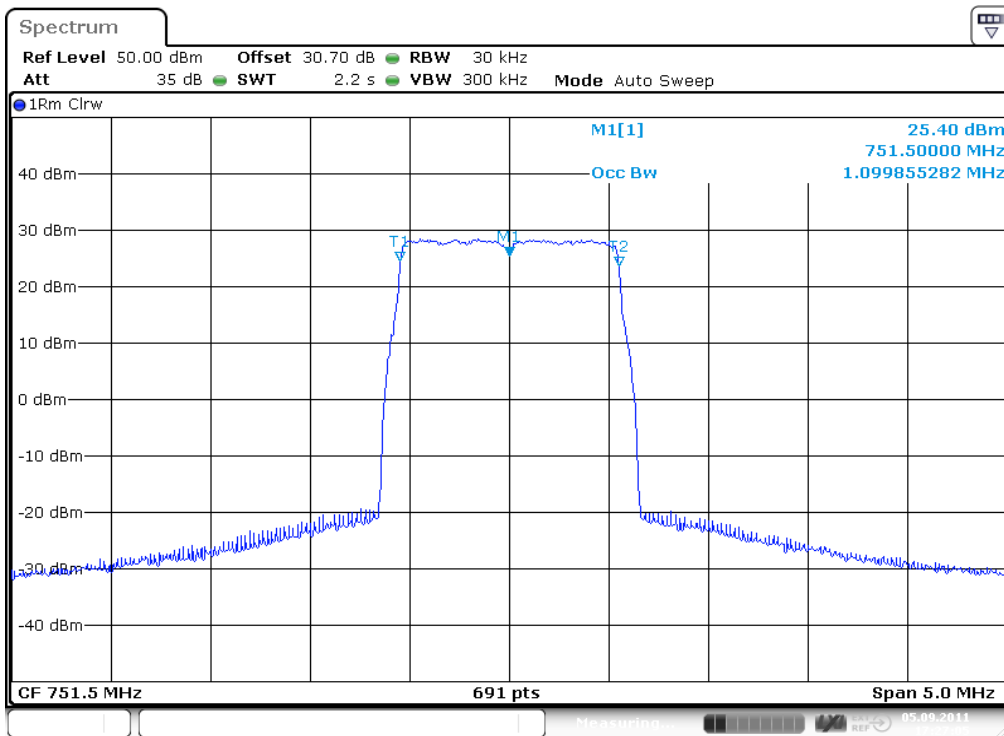

Date: 5.SEP.2011 17:27:05

plot 6.3.1.2-#1 Occupied Bandwidth: §90.210, §2.1049; Test results; Downlink; LTE 746 – 757MHz Output

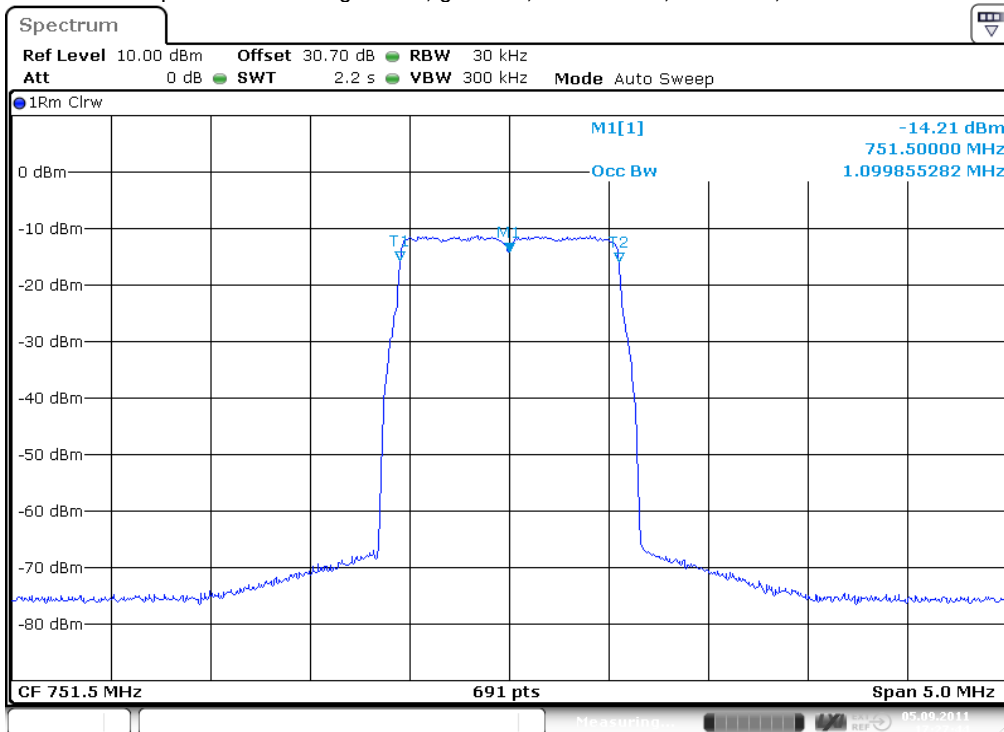

Date: 5.SEP.2011 17:27:44

plot 6.3.1.2-#2 Occupied Bandwidth: §90.210, §2.1049; Test results; Downlink; LTE 746 – 757MHz Input

Test Report No.: 13-238

FCC ID: XS5-M7P17HP

IC ID: 2237E-M7P17HP



**BUREAU
VERITAS**

6.3.2 Uplink

n.a.

Note: The EUT does not transmit over the air in the uplink direction.

6.4 Summary test result

Test result	complies, according the plots above
Tested by:	M. Leinfelder
Date:	05.09.2011

7 Spurious Emissions at Antenna Terminals: §27.53, §2.1051

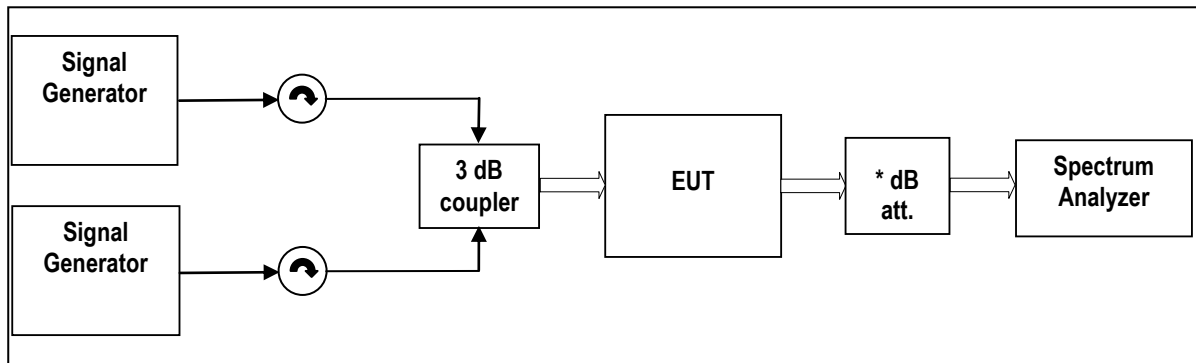

External Attenuator DL x dB = 30 dB

figure 7-#1 Test setup: Spurious Emissions at Antenna Terminals: §27.53, §2.1051

Measurement uncertainty	± 0,54 dB ± 1,2 dB ± 1,5 dB	9 kHz to 3 GHz 3 GHz to 7 GHz 7 GHz to 26 GHz
Test equipment used	9126, 9069, 8667, 8668 9126, 9069, 8667, 8668, 7406	

7.1 Limit

Minimum standard:

Para. No.27.53 (c), (f) and (g)

(c) For operations in the 746–758 MHz band and the 776–788 MHz band, the power of any emission outside the licensee's frequency band(s) of operation shall be attenuated below the transmitter power (P) within the licensed band(s) of operation, measured in watts, in accordance with the following:

(1) On any frequency outside the 746–758 MHz band, the power of any emission shall be attenuated outside the band below the transmitter power (P) by at least $43 + 10 \log (P)$ dB;

(3) On all frequencies between 763–775 MHz and 793–805 MHz, by a factor not less than $76 + 10 \log (P)$ dB in a 6.25 kHz band segment, for base and fixed stations;

(f) For operations in the 746–763 MHz, 775–793 MHz, and 805–806 MHz bands, emissions in the band 1559–1610 MHz shall be limited to -70 dBW/MHz equivalent isotropically radiated power (EIRP) for wideband signals, and -80 dBW EIRP for discrete emissions of less than 700 Hz bandwidth. For the purpose of equipment authorization, a transmitter shall be tested with an antenna that is representative of the type that will be used with the equipment in normal operation.

(g) For operations in the 698–746 MHz band, the power of any emission outside a licensee's frequency band(s) of operation shall be attenuated below the transmitter power (P) within the licensed band(s) of operation, measured in watts, by at least $43 + 10 \log (P)$ dB. Compliance with this provision is based on the use of measurement instrumentation employing a resolution bandwidth of 100 kilohertz or greater. However, in the 100 kilohertz bands immediately outside and adjacent to a licensee's frequency block, a resolution bandwidth of at least 30 kHz may be employed



7.2 Test method

Para. No 2.1051 Measurements required: Spurious emissions at antenna terminals.

The radio frequency voltage or powers generated within the equipment and appearing on a spurious frequency shall be checked at the equipment output terminals when properly loaded with a suitable artificial antenna. Curves or equivalent data shall show the magnitude of each harmonic and other spurious emission that can be detected when the equipment is operated under the conditions specified in § 2.1049 as appropriate. The magnitude of spurious emissions which are attenuated more than 20 dB below the permissible value need not be specified.

[39 FR 5919, Feb. 15, 1974. Redesignated and amended at 63 FR 36599, July 7, 1998]

7.3 Test results

7.3.1 Downlink

<1MHz from Band Edge

Detector: RMS.

Modulation	Measured at Band Edge	Carriers	RBW VBW Span	Max. level (dBm)	Plot -
LTE Band 12 (Band Class 19)	Lower Edge	728,7 MHz 730,1 MHz	30kHz 300kHz 6MHz	-21.6	7.3.1.1 #1
	Upper Edge	743,9 MHz 745,3 MHz			#2
LTE Band 13 (Band Class 7)	Lower Edge	746,7 MHz 748,1 MHz	30kHz 300kHz 6MHz	-19.8	7.3.1.2 #1
	Upper Edge	754,9 MHz 756,3 MHz			#2

table 7.3-#1 Spurious Emissions at Antenna Terminals: §27.53, §2.1051 Test results <1MHz from Band

>1MHz from Band Edge

Detector: RMS.

Modulation	Carrier	RBW VBW Span	Max. level (dBm)	Plot -
LTE	737 MHz	1MHz 3MHz 30MHz – 8GHz	-22.9	7.3.1.3 #1
LTE	751.5 MHz	1MHz 3MHz 30MHz – 8GHz	-22.8	7.3.1.4 #1

table 7.3-#2 Spurious Emissions at Antenna Terminals: §27.53, §2.1051 Test results >1MHz from Band Edge



Calculation of the limit according to §27.53 (c)(3):

On all frequencies between 763–775 MHz and 793–805 MHz, by a factor not less than $76 + 10 \log (P)$ dB in a 6.25 kHz band segment, for base and fixed stations;

$$P_{out} = 43\text{dBm} = 20\text{W}.$$

$76 + 10 \cdot \log(20\text{W}/1\text{W})$ dB = 89 dB Attenuation $\Rightarrow 43\text{dBm} - 89\text{dB} = -46$ dBm in a 6.25 kHz band segment
Spurious measured in the plot with a RBW of 1MHz so the limit is calculated:

$$\Rightarrow -46\text{dBm} / 6,25\text{kHz} + 10 \cdot \log(1\text{MHz}/6,25\text{kHz}) = -23,96\text{dBm} / 1\text{MHz}$$

(in the frequency range 763–775 MHz and 793–805 MHz)

maximum measured emission level for frequencies between 763–775 MHz and 793–805 MHz is below -30 dBm / 1MHz.

Test passed.

Considerations to §27.53 (f):

To see if the standard 27.53(f) were met a calculation of the radiated power is necessary. The modulated carrier in the range of 747-757 MHz is working with maximum power of 43dBm and the frequency range of 1559-1610MHz is measured. For the calculation of the radiated power in this band, it was calculated with a typical antenna gain and typical cable loss.

Used 700 MHz narrow band antennas offer a gain of 0 dBi in the in the frequency range 1559 - 1610 MHz, furthermore an antenna cable with a loss of 2 dB is used.

The measured conducted emissions in the frequency range of 1599 - 1610 MHz are below -65 dBm/MHz (see at plot 7.3.1.5).

Conducted emissions (< -65 dBm) + antenna gain (0 dBi) - cable loss (0 dB) = radiated emissions (< -65 dBm) which is below the limit of Part 27.53(f).

Even with an antenna gain of 20 dBi (more than worst case) in the frequency range of 1599 - 1610 MHz, we are still under the limit of Part 27.53(f) with a radiated emission of -45 dBm.

Therefore the emission limit is met.

Test passed.

Plots with test result see

7.3.1.5 Measurement in the band of 1559 MHz – 1610 MHz



7.3.1.1 LTE < 1MHz to band edge; 728 – 746MHz

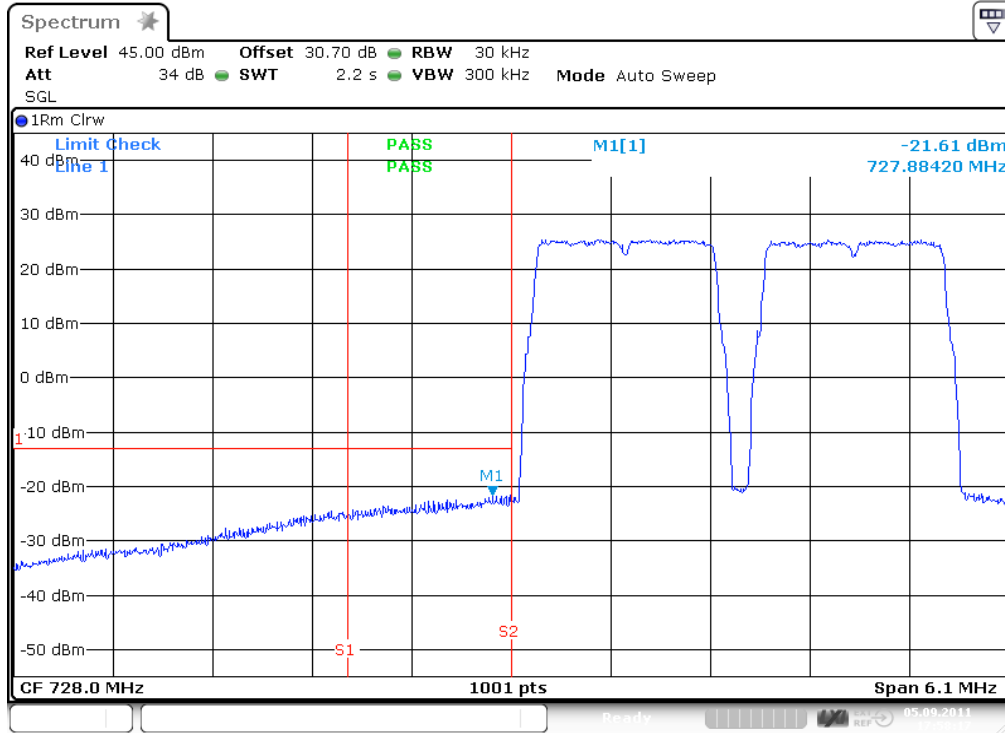

Date: 5.SEP.2011 17:58:18

plot 7.3.1.1-#1 Spurious Emissions at Antenna Terminals: §27.53, §2.1051; Test results; Downlink; LTE < 1MHz to band edge; 728 – 746MHz Lower Band Edge

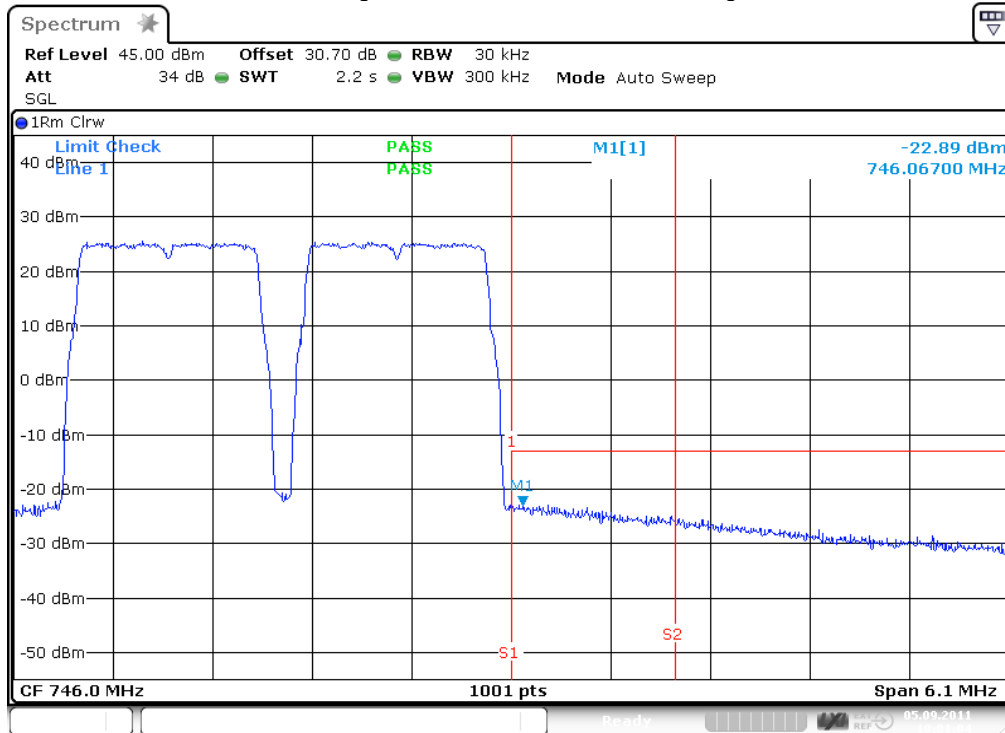

Date: 5.SEP.2011 18:01:05

plot 7.3.1.1-#2 Spurious Emissions at Antenna Terminals: §27.53, §2.1051; Test results; Downlink; LTE < 1MHz to band edge; 728 – 746MHz Upper Band Edge



7.3.1.2 LTE < 1MHz to band edge 746 – 757MHz

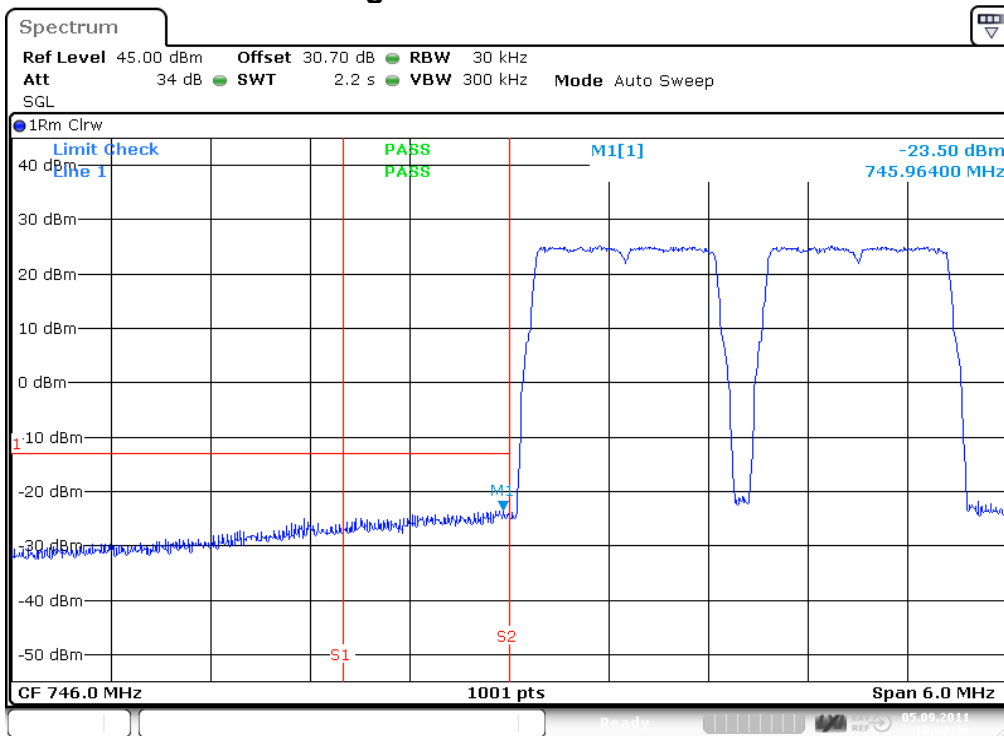

Date: 5.SEP.2011 18:02:49

plot 7.3.1.2-#1 Spurious Emissions at Antenna Terminals: §27.53, §2.1051; Test results; Downlink; LTE < 1MHz to band edge 746 – 757MHz Lower Band Edge

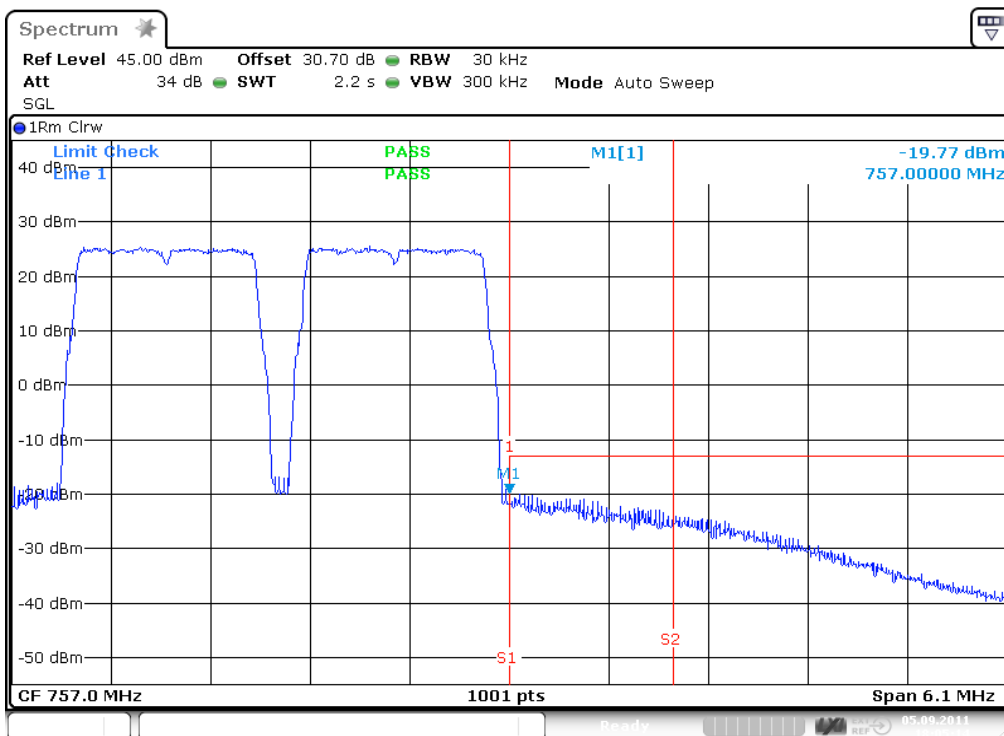

Date: 5.SEP.2011 18:05:14

plot 7.3.1.2-#2 Spurious Emissions at Antenna Terminals: §27.53, §2.1051; Test results; Downlink; LTE < 1MHz to band edge 746 – 757MHz Upper Band Edge



7.3.1.3 LTE > 1MHz to band edge 728 – 746MHz

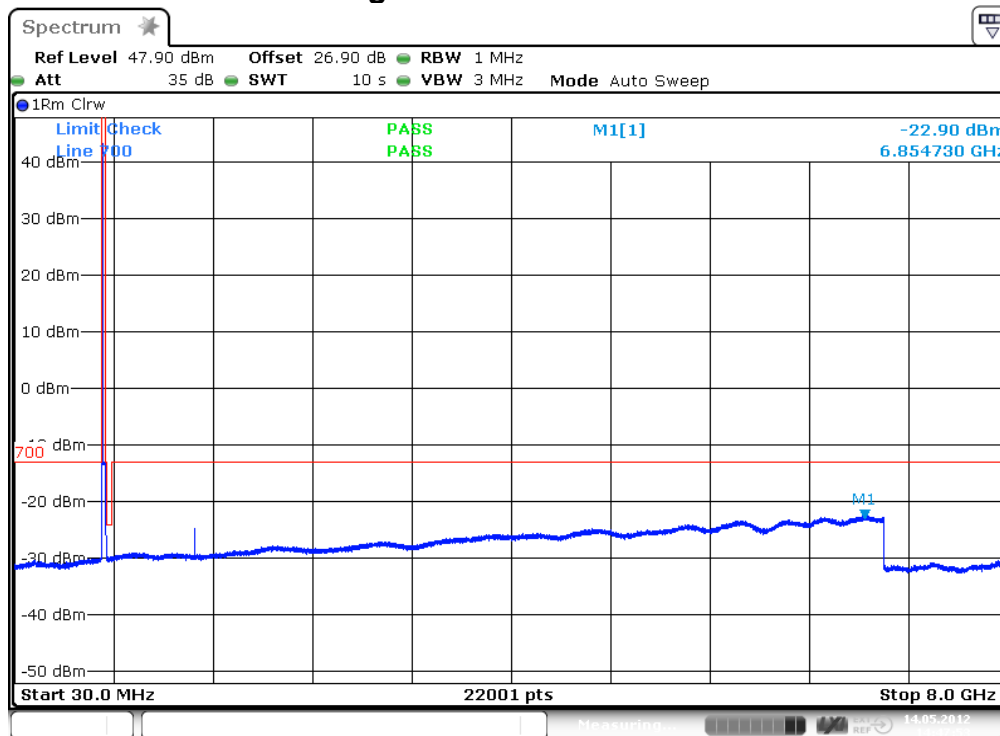

Date: 14.MAY.2012 14:47:53

plot 7.3.1.3-#1 Spurious Emissions at Antenna Terminals: §27.53, §2.1051; Test results; Downlink; LTE > 1MHz to band edge 728 – 746MHz

7.3.1.4 LTE > 1MHz to band edge 746 – 757MHz; carrier at 751,5MHz

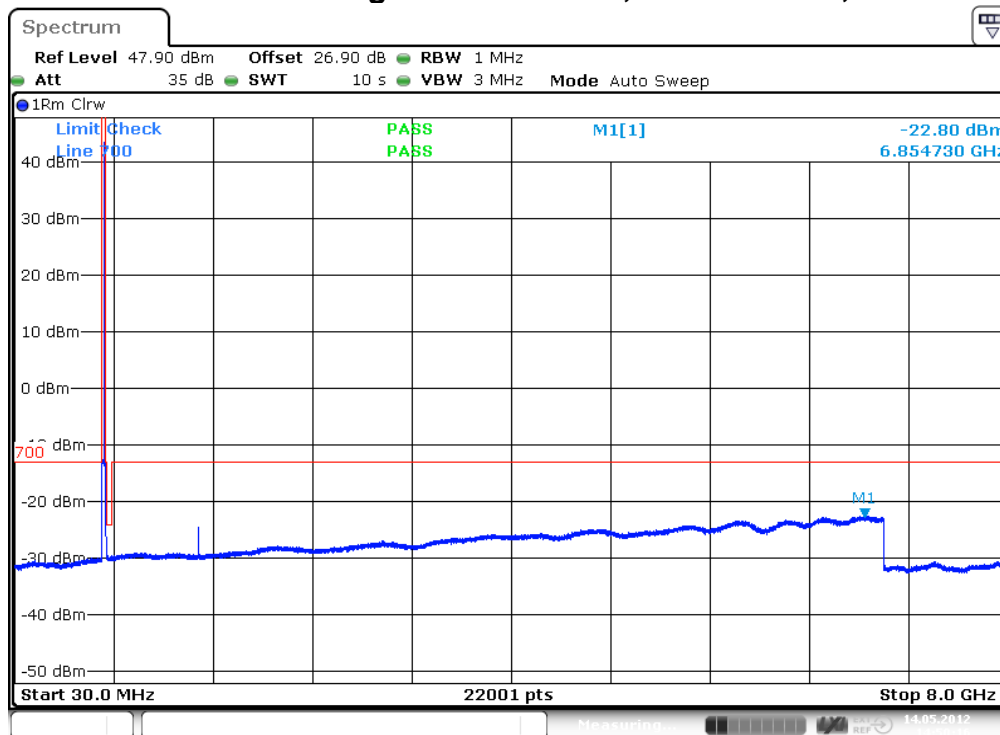

Date: 14.MAY.2012 14:50:16

plot 7.3.1.4-#1 Spurious Emissions at Antenna Terminals: §27.53, §2.1051; Test results; Downlink; LTE > 1MHz to band edge 746 – 757MHz; carrier at 751,5MHz;



7.3.1.5 Measurement in the band of 1559 MHz – 1610 MHz acc. to 27.53(f)

Calculations see 7.3.1 Test results Downlink

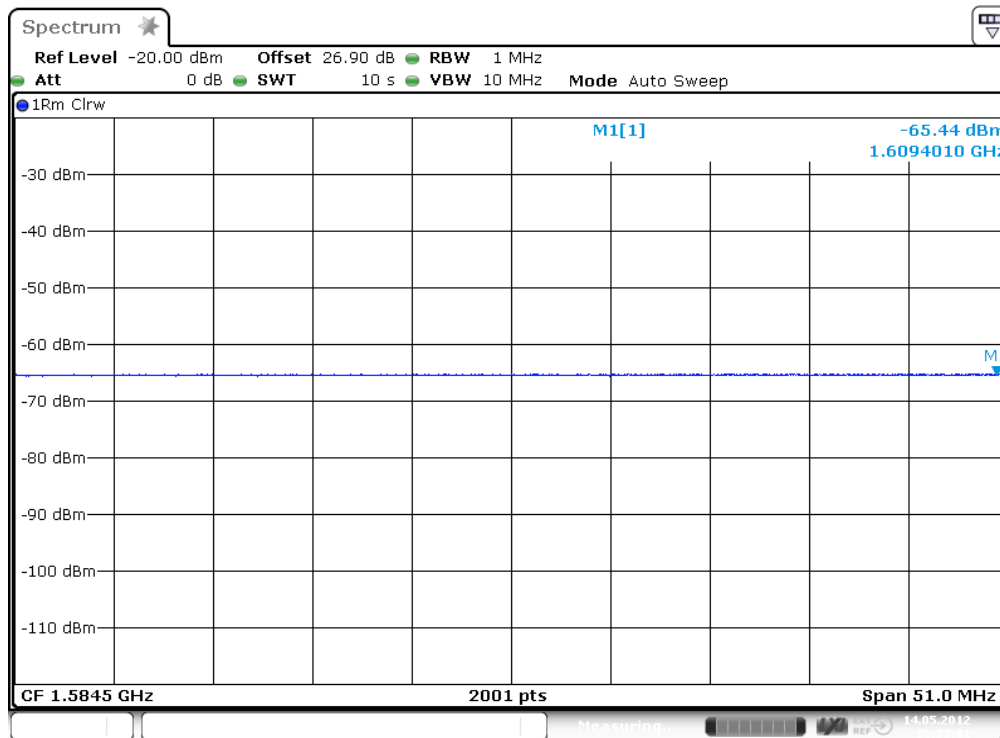

Date: 14.MAY.2012 15:23:11

plot 7.3.1.5-#1 Spurious Emissions at Antenna Terminals: §27.53, §2.1051; Test results; Downlink; Measurement in the band of 1559 MHz – 1610 MHz acc. to 27.53(f)

7.3.2 Uplink

n.a.

Note: The EUT does not transmit over the air in the uplink direction.

7.4 Summary test result

Test result	complies, according the plots above
Tested by:	M. Leinfelder / W. Meir
Date:	05.09.2011 / 14.05.2012

8 Amplifier Gain and Bandwidth: IC RSS-131

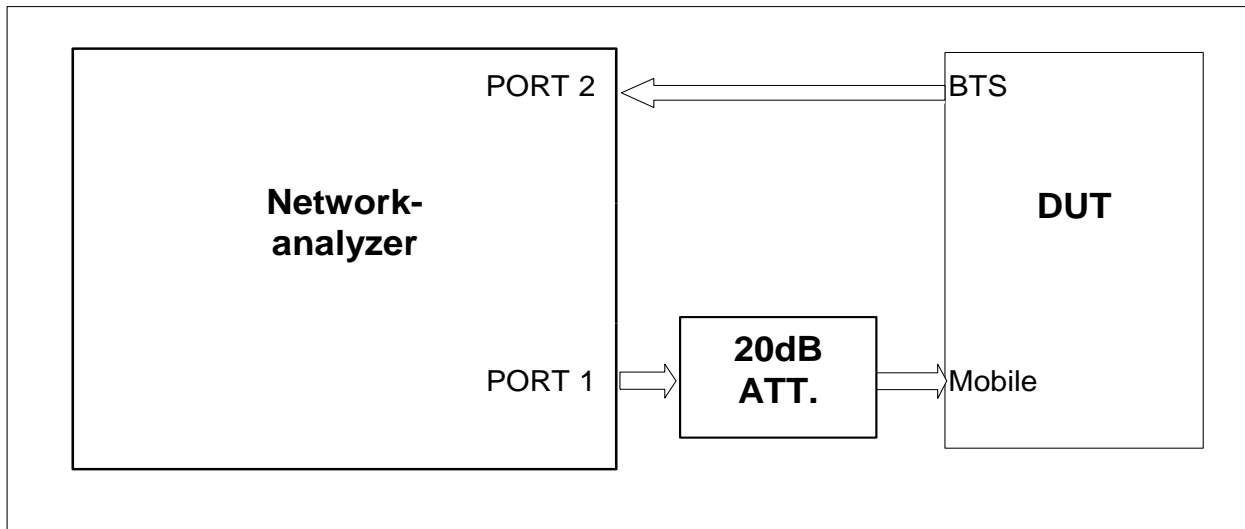

figure 8-#1 Test setup: Amplifier Gain and Bandwidth: IC RSS-131

Test equipment used	9126, 9069, 8667, 8668, 7406
---------------------	------------------------------

8.1 Limit

IC RSS-131 clause 6.1

The passband gain shall not exceed the nominal gain by more than 1.0 dB. The 20 dB bandwidth shall not exceed the nominal bandwidth that is stated by the manufacturer. Outside of the 20 dB bandwidth, the gain shall not exceed the gain at the 20 dB point.

8.2 Test method

IC RSS-131 clause 4.2

Adjust the internal gain control of the equipment under test to the nominal gain for which equipment certification is sought.

With the aid of a signal generator and spectrum analyser, measure the 20 dB bandwidth of the amplifier (i.e. at the point where the gain has fallen by 20 dB). Measure the gain-versus-frequency response of the amplifier from the midband frequency f_0 of the passband up to at least $f_0 \pm 250\%$ of the 20 dB bandwidth.

8.3 Test results

8.3.1 Downlink

Passband gain	40,95 dB
Lower limit of 20dB Bandwidth	724,1 MHz
Upper limit of 20dB Bandwidth	762,0 MHz
20dB Bandwidth	37,9 MHz

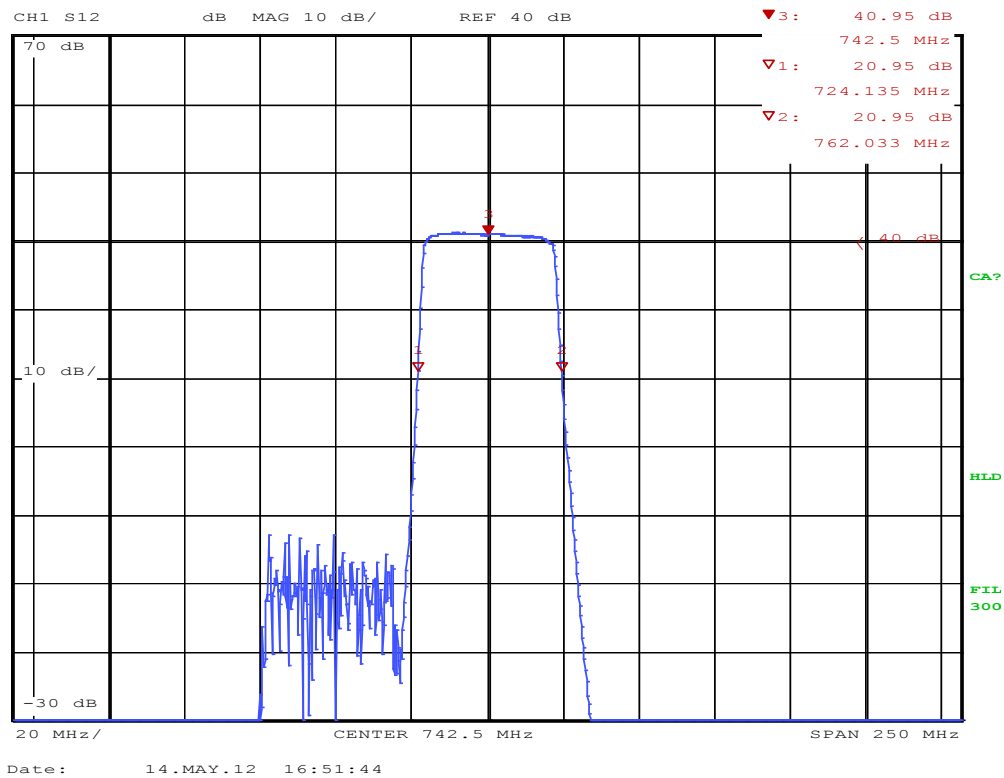

plot 8.3.1-#1 Amplifier Gain and Bandwidth: IC RSS-131; Test results; Downlink

8.3.2 Uplink

n.a.

Note: The EUT does not transmit over the air in the uplink direction.

8.4 Summary test result

Test result	complies, according the plots above
Tested by:	W. Meir
Date:	14.05.2012



9 Output Power: IC RSS-131

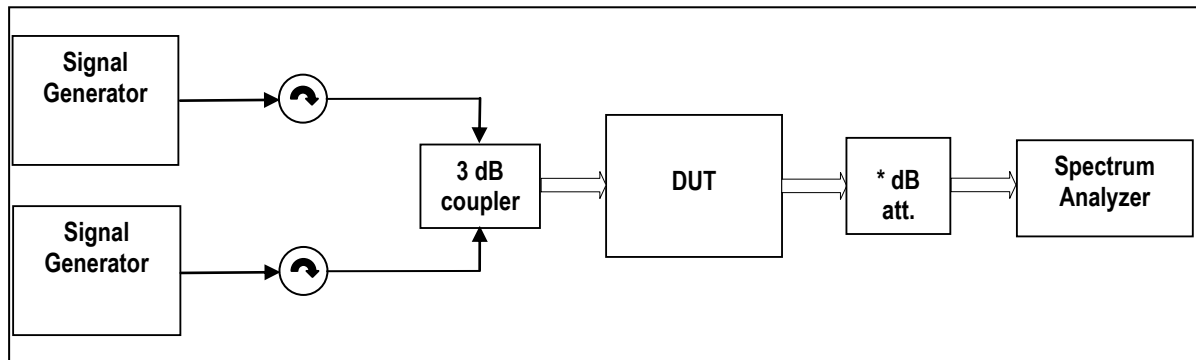

External Attenuator DL x dB = 30 dB
figure 9-#1 Test setup: Output Power: IC RSS-131

Measurement uncertainty	± 0,38 dB
Test equipment used	9126, 9069, 8667, 8668, 7406

9.1 Limit

IC RSS-131 clause 6.2

The manufacturer's output power rating P rated MUST NOT be greater than P mean for all types of enhancers.

9.2 Test method

IC RSS-131 clause 4.3.1 Multi-channel Enhancer

The following subscript "o" denotes a parameter at the enhancer output point.

Connect two signal generators to the input of the Device Under Test (DUT), via a proper impedance matching network (and preferably via a variable attenuator) so that the two input signals are equal sinusoids (and can be raised equally).

Connect a dummy load of suitable load rating to the enhancer output point. Connect also a spectrum analyser to this output point via a coupling network and attenuator, so that only a portion of the output signal is coupled to the spectrum analyser. The coupling attenuation shall be stated in the test report.

Set the two generator frequencies f_1 and f_2 such that they and their third-order intermodulation product frequencies, $f_3 = 2f_1 - f_2$ and $f_4 = 2f_2 - f_1$, are all within the passband of the DUT.

Raise the input level to the DUT while observing the output tone levels, P_{o1} and P_{o2} , and the intermodulation product levels, P_{o3} and P_{o4} .

For enhancers rated 500 watts or less: Raise the input level to the DUT until the greater level of the intermodulation products at the enhancer output terminals, P_{o3} or P_{o4} , equals -43 dBW.

For enhancers rated over 500 watts: Raise the input level to the DUT until the greater level of the intermodulation products at the enhancer output terminals, P_{o3} or P_{o4} , is 67 dB below the level of either output tone level, P_{o1} or P_{o2} .

Record all signal levels and their frequencies. Calculate the mean output power (P_{mean}) under this testing condition using $P_{mean} = P_{o1} + 3$ dB.



9.3 Test results

9.3.1 Downlink

$P_{01} @ f_1$	40.0 dBm @ 742.0 MHz
$P_{02} @ f_2$	40.0 dBm @ 744,5 MHz
$P_{03} @ f_3$	-21.8 dBm @ 739,5 MHz
$P_{04} @ f_4$	-22.6 dBm @ 747,0 MHz

$$P_{\text{mean}} = P_{01} + 3 \text{ dB}$$

$$P_{\text{mean}} = 40.0 \text{ dBm} + 3 \text{ dB} = 43 \text{ dBm}$$

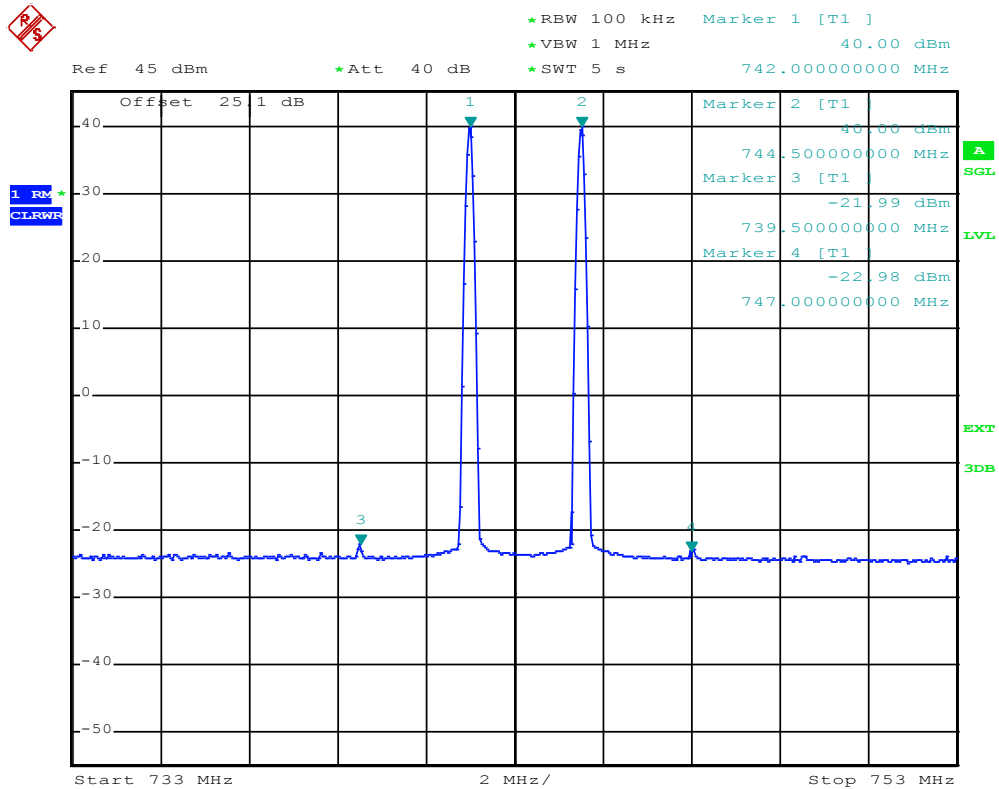

Date: 15.MAY.2012 15:02:19

plot 9.3.1-#1 Output Power: IC RSS-131; Test results; Downlink

9.3.2 Uplink

n.a.

Note: The EUT does not transmit over the air in the uplink direction.

Test Report No.: 13-238

FCC ID: XS5-M7P17HP

IC ID: 2237E-M7P17HP



BUREAU
VERITAS

9.4 Summary test result

Test result	complies, according the plots above
Tested by:	W. Meir
Date:	15.05.2012

10 Non-Linearity: IC RSS-131

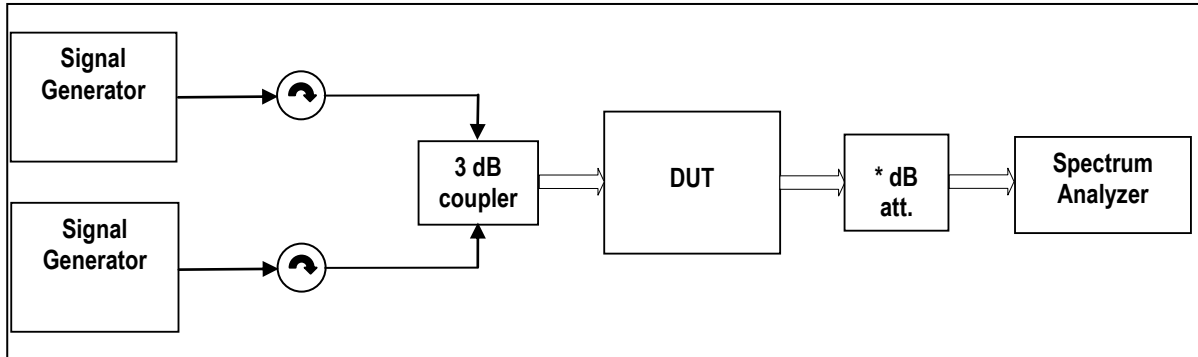

External Attenuator DL x dB = 30 dB
figure 10-#1 Test setup: Non-Linearity: IC RSS-131

Test equipment used	9126, 9069, 8667, 8668, 7406
---------------------	------------------------------

10.1 Limit

RSS-131 clause 6.3

Transmitter signals amplified by a non-linear device (enhancer or translator) will alter the occupied bandwidth of the transmitted signals; therefore, the extent of non-linearity shall be tested.

RSS-131 clause 6.3.1

For a multi-channel enhancer, any intermodulation product level must be attenuated, relative to P, by at least:

$$43 + 10 \log_{10} P, \text{ or } 70 \text{ dB, whichever is less stringent,}$$

where P is the total RF output power of the test tones in watts.

10.2 Test method

IC RSS-131 clause 4.3.1 Multi-channel Enhancer

The following subscript "o" denotes a parameter at the enhancer output point.

Connect two signal generators to the input of the Device Under Test (DUT), via a proper impedance matching network (and preferably via a variable attenuator) so that the two input signals are equal sinusoids (and can be raised equally).

Connect a dummy load of suitable load rating to the enhancer output point. Connect also a spectrum analyser to this output point via a coupling network and attenuator, so that only a portion of the output signal is coupled to the spectrum analyser. The coupling attenuation shall be stated in the test report.

Set the two generator frequencies f_1 and f_2 such that they and their third-order intermodulation product frequencies, $f_3 = 2f_1 - f_2$ and $f_4 = 2f_2 - f_1$, are all within the passband of the DUT.

Raise the input level to the DUT while observing the output tone levels, P_{o1} and P_{o2} , and the intermodulation product levels, P_{o3} and P_{o4} .



10.3 Test results

10.3.1 Downlink

Requirement calculation:

$$P = 40,0 \text{ dBm} = 10,0 \text{ W}$$

Attenuation = $40 + 10\text{Log}_{10}(10 \text{ W})$ or 70 dB whichever is less stringent

Attenuation = 53 dB or 70 dB whichever is less stringent

Attenuation = 53 dB

Test result:

$$\text{Delta P to IMD} = 40,0 \text{ dBm} - (-21,8 \text{ dBm}) = 61,8 \text{ dB}$$

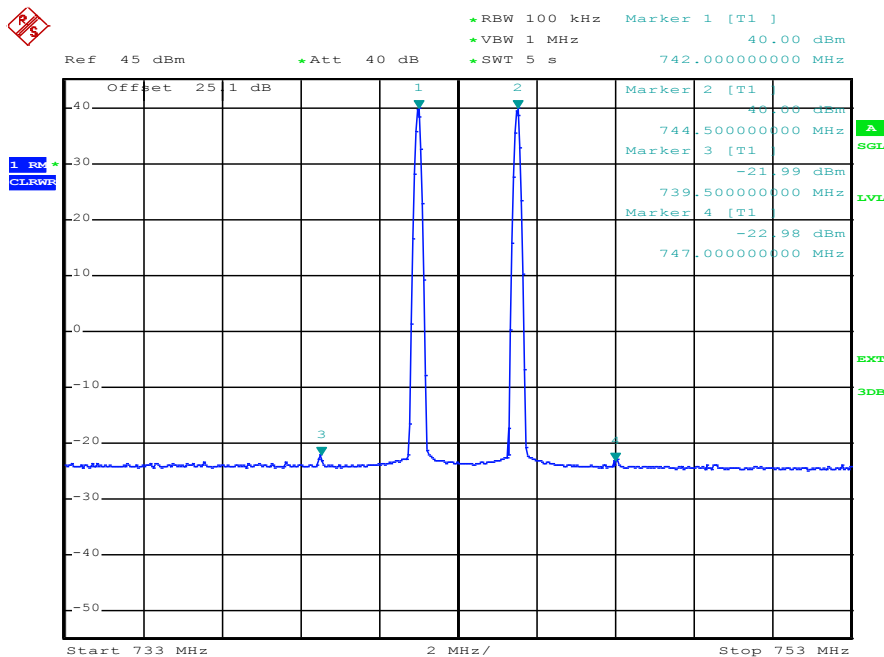

Date: 15.MAY.2012 15:00:57

plot 10.3.1-#1 Non-Linearity: IC RSS-131; Test results; Downlink

10.3.2 Uplink

n.a.

Note: The EUT does not transmit over the air in the uplink direction.

10.4 Summary test result

Test result	complies, according the plots above
Tested by:	W. Meir
Date:	15.05.2012

11 Spurious Emissions: RSS-131

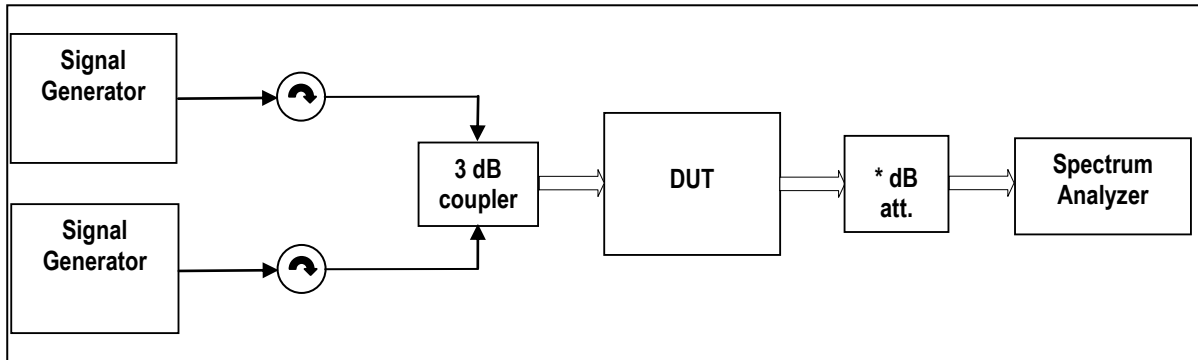

External Attenuator DL x dB = 30 dB
figure 11-#1 Test setup: Spurious Emissions: RSS-131

Measurement uncertainty	± 0,54 dB ± 1,2 dB ± 1,5 dB	9 kHz to 3 GHz 3 GHz to 7 GHz 7 GHz to 13,6 GHz
Test equipment used	9126, 9069, 8667, 8668, 7406	

11.1 Limit

RSS-131 clause 6.4

Spurious emissions of zone enhancers and translators shall be suppressed as much as possible.

Spurious emissions shall be attenuated below the rated power of the enhancer by at least:

$43 + 10 \log_{10}(P \text{ rated in watts})$, or 70 dB, whichever is less stringent.

11.2 Test method

RSS-131 clause 4.4.1

The spurious emissions of the equipment under test shall be measured using the two-tone method in section 4.3.1, with the two tones P_{o1} and P_{o2} set to the required levels.

Using a spectrum analyser with a resolution bandwidth set at 100 kHz, search for spurious emissions from 30 MHz to at least 5 times the highest RF passband frequency. The search may omit the band that contains the test tones and intermodulation products.

11.3 Test results

11.3.1 Downlink

Requirement calculation:

$P = 43,0 \text{ dBm}$

Attenuation = $43 + 10 \log_{10}(10 \text{ W})$ or 70 dB whichever is less stringent

Attenuation = 53 dB or 70 dB whichever is less stringent

Attenuation = 53 dB

Test result:

Delta P to IMD = $43,0 \text{ dBm} - (-21,8 \text{ dBm}) = 61,8 \text{ dB}$

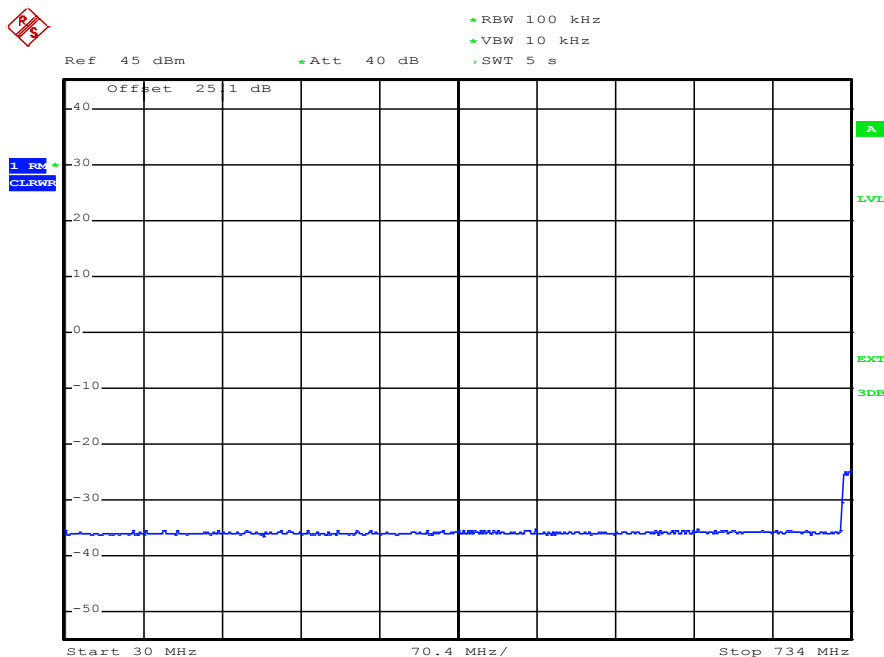

Date: 15.MAY.2012 14:04:35

plot 11.3.1-#1 Spurious Emissions: RSS-131; Test results; Downlink; 30 MHz – 734 MHz

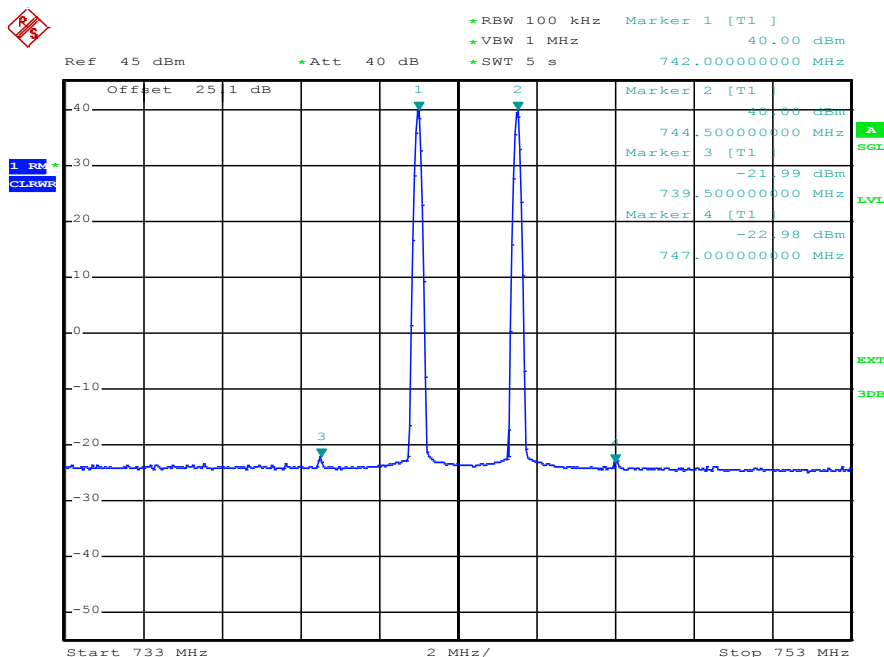

Date: 15.MAY.2012 15:00:41

plot 11.3.1-#2 Spurious Emissions: RSS-131; Test results; Downlink; 851 MHz – 869 MHz

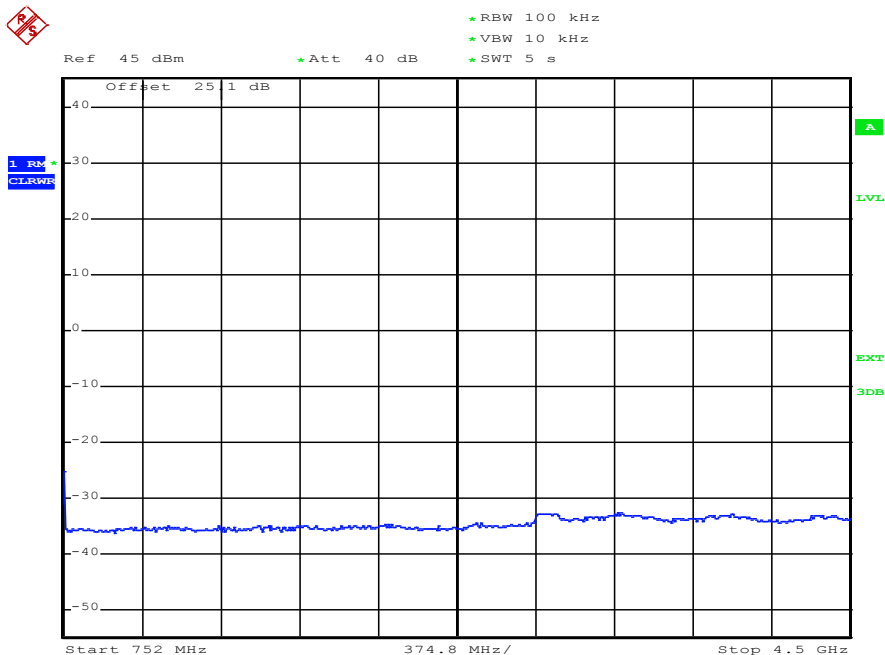

Date: 15.MAY.2012 14:51:30

plot 11.3.1-#3 Spurious Emissions: RSS-131; Test results; Downlink; 869 MHz – 4.5 GHz

11.3.2 Uplink

n.a.

Note: The EUT does not transmit over the air in the uplink direction.

11.4 Summary test result

Test result	complies, according the plots above
Tested by:	W. Meir
Date:	15.05.2012

12 Radiated Spurious Emissions at the ECL (BV): §27.53, §2.1053, RSS-Gen, RSS-131



picture 8.1: label

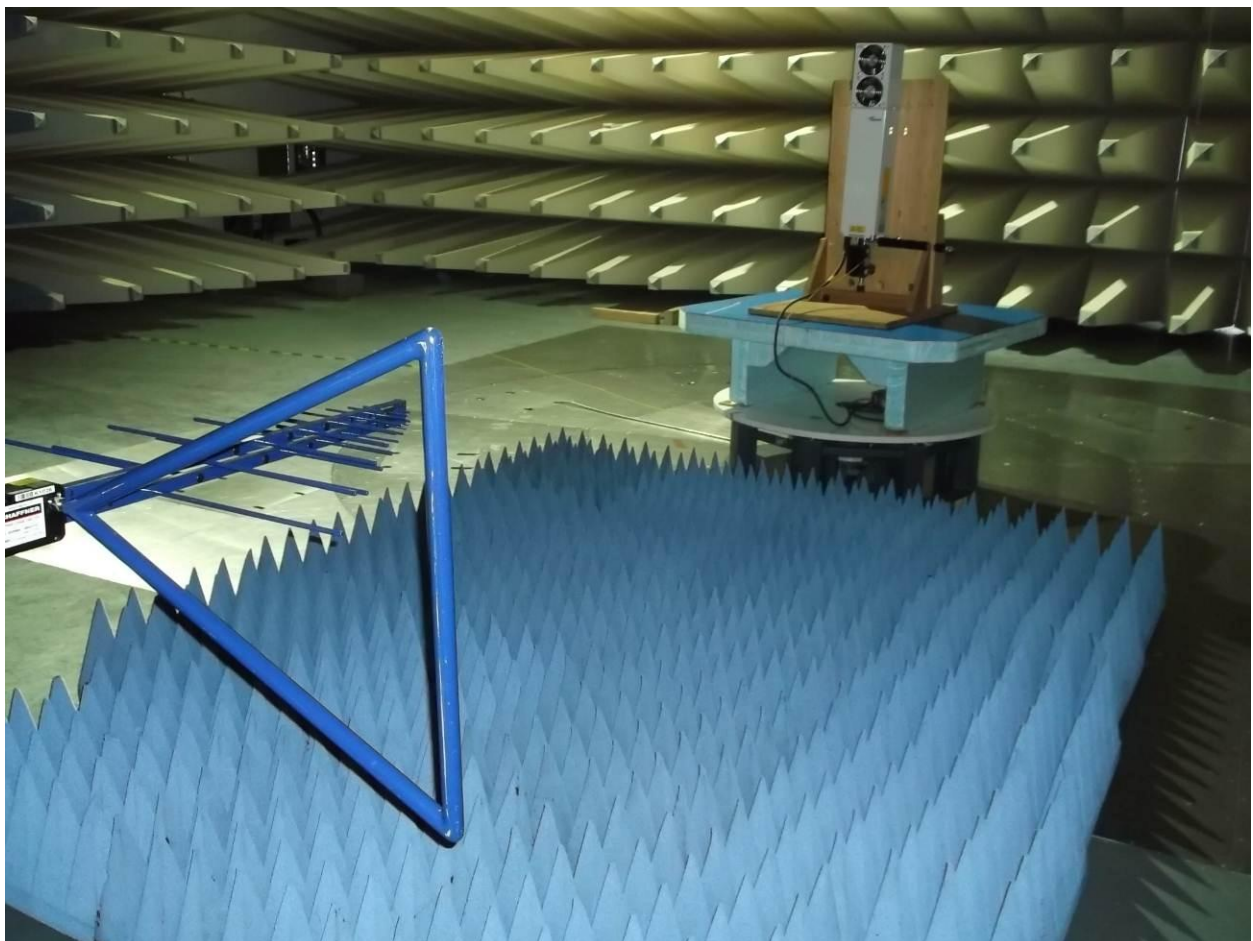

picture 8.2: Test setup: Field Strength Emission <1 GHz @3m in the SAC

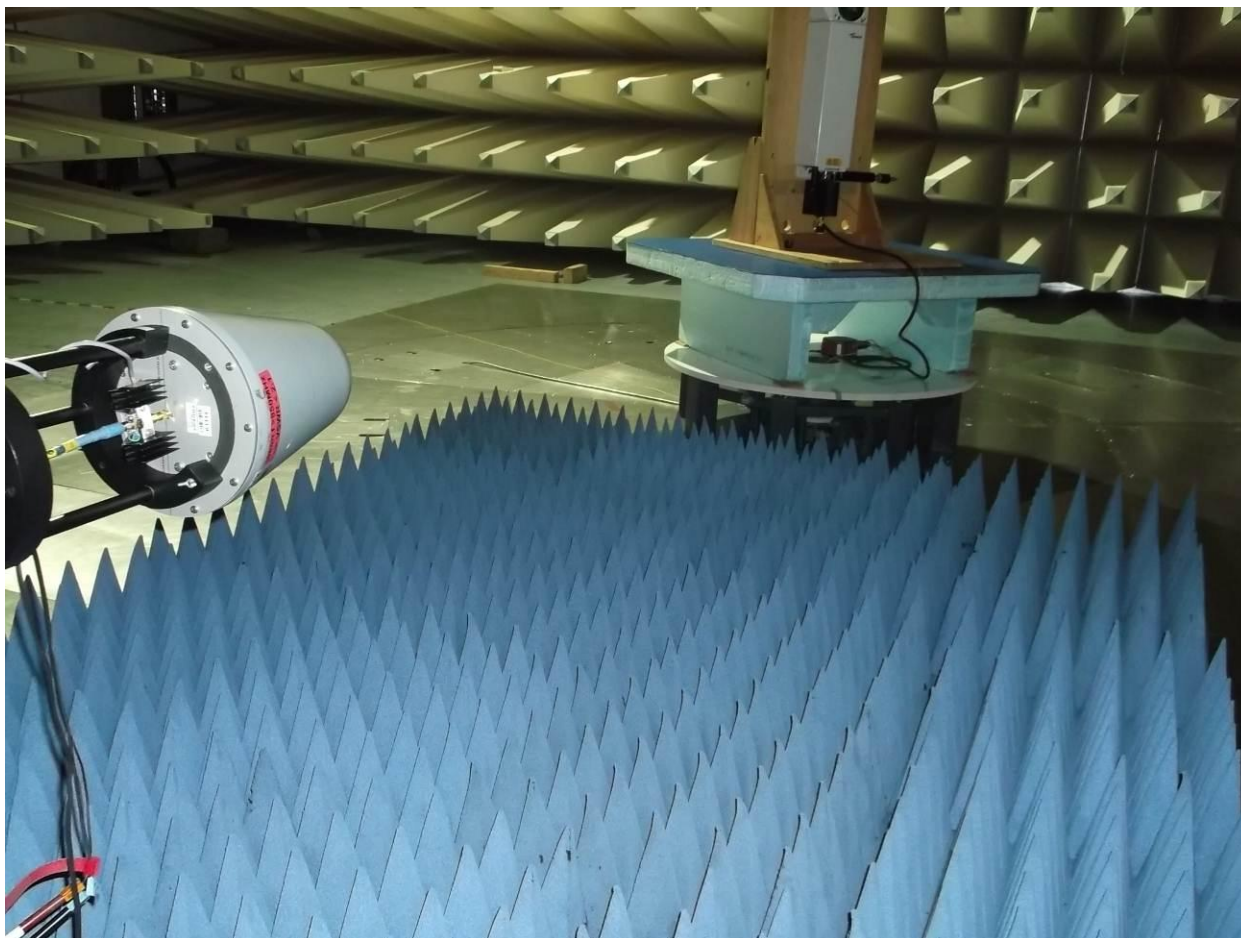

picture 8.3: Test setup: Field Strength Emission >1 GHz @3m in the SAC

Test Report No.: 13-238

FCC ID: XS5-M7P17HP

IC ID: 2237E-M7P17HP



**BUREAU
VERITAS**

This clause specifies requirements for the measurement of radiated emission.

Frequency range	Distance: EUT <-> antenna / location	Limit	Test method
30 MHz – 22 GHz	3 metres / SAC	FCC 47 CFR Part 27.53 IC RSS-131 sec. 4.4	TIA/EIA-603-C:2004

Test equipment used:

Designation	Type	Manufacturer	Invent.-no.	Cal.-date	due Cal.- date	used
EMI test receiver	ESI40	Rohde & Schwarz	E1687	19.12.2012	19.12.2013	X
Antenna	CBL 6111	Chase	K1149	12.06.2013	12.06.2014	X
RF Cable		Frankonia	K1121 SET	20.02.2013	20.02.2014	X
Antenna	HL 025	R&S	K809	31.07.2013	31.07.2014	X
Preamplifier	AFS4-00102000	Miteq	K817	27.03.2013	27.03.2014	X
RF Cable	Sucoflex 100	Suhner	K1742	27.03.2013	27.03.2014	X

The REMI version 2.135 has been used to maximize radiated emission from the EUT with regards to ANSI C63.4:2009.

Test set-up:

Test location: SAC
Both, the Fully Anechoic Chamber (FAC) and the Semi Anechoic Chamber (SAC) fulfil the requirements of ANSI C63.4 and CISPR 16-1-4 with regards to NSA and SVSWR.

Test Voltage: 110V / 60 Hz
Type of EUT: Wall mounted

Measurement uncertainty:

Measurement uncertainty expanded (95% or K=2)	± 4,7 dB for ANSI C63.4 measurement ± 0,5 dB for TIA-603 measurement
--	---

12.1 Method of Measurement

Measurement procedure. TIA-603-C

The antenna substitution method is used to determine the equivalent radiated power at spurious frequencies. The spurious emissions are measured at a distance of 3 meters. The EUT is then replaced with a reference substitution antenna with a known gain referenced to a dipole. This antenna is fed with a signal at the spurious frequency. The level of the signal is adjusted to repeat the previously measured level. The resulting eirp is the signal level fed to the reference antenna corrected for gain referenced to an isotropic dipole (see Figure 7.2).

From KDB (AMPLIFIER, BOOSTER, AND REPEATER REMINDER SHEET):

Radiated spurs (enclosure) – Use of CW signal (low, mid, and high freq.) is acceptable rather than all modulations. The Bottom/Middle/Top frequencies for Part 27 F/H are as follows:

- 728/737/746 MHz (§27 Subpart H)
- 746/755/763 MHz (§27 Subpart F)

The maximum RFI field strength was determined during the measurement by rotating the turntable (± 180 degrees) as like defined in ANSI C63.4. A measurement receiver has been used with a RBW 120 kHz up to 1 GHz and 1 MHz above 1 GHz. Steps width during the measurement was half the RBW.

Both, the Fully Anechoic Chamber (FAC) and the Semi Anechoic Chamber (SAC) fulfil the requirements of ANSI C63.4 and CISPR 16-1-4 with regards to NSA and SVSWR.

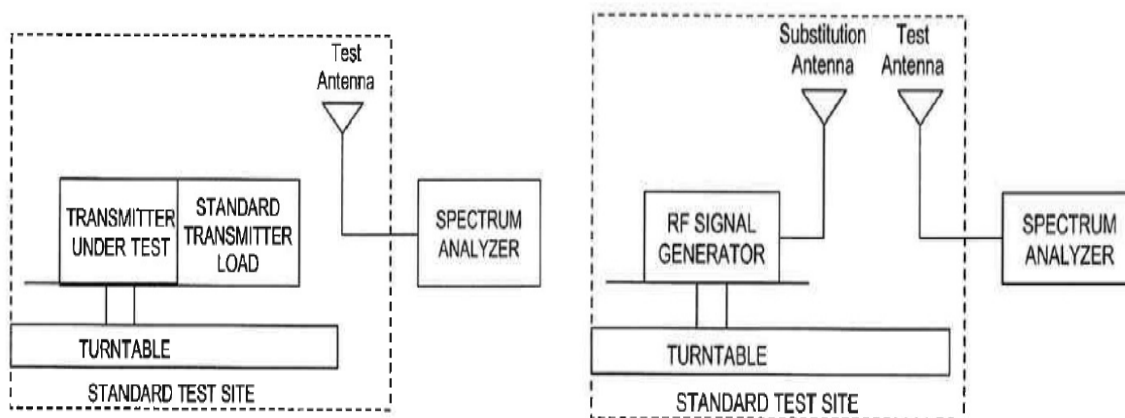

Figure #8.3 Substitution methods TIA/EIA-603-C



12.2 Limit

§27.53 Emission limitations / RSS-GEN sec. 4.9; RSS-131 sec. 4.4

Minimum standard:

Para. No.27.53 (c/d/g)

(c) For operations in the 746–758 MHz band and the 776–788 MHz band, the power of any emission outside the licensee's frequency band(s) of operation shall be attenuated below the transmitter power (P) within the licensed band(s) of operation, measured in watts, in accordance with the following:

(1) On any frequency outside the 746–758 MHz band, the power of any emission shall be attenuated outside the band below the transmitter power (P) by at least $43 + 10 \log (P)$ dB.

(g) For operations in the 698–746 MHz band, the power of any emission outside a licensee's frequency band(s) of operation shall be attenuated below the transmitter power (P) within the licensed band(s) of operation, measured in watts, by at least $43 + 10 \log (P)$ dB. Compliance with this provision is based on the use of measurement instrumentation employing a resolution bandwidth of 100 kilohertz or greater. However, in the 100 kilohertz bands immediately outside and adjacent to a licensee's frequency block, a resolution bandwidth of at least 30 kHz may be employed

The Emission limit is **-13dBm**.

(d) For operations in the 758–763 MHz and 788–793 MHz bands, the power of any emission outside the licensee's frequency bands of operation shall be attenuated below the transmitter power (P) within the licensed band(s) of operation, measured in watts, in accordance with the following:

(1) On all frequencies between 769–775 MHz and 799–805 MHz, by a factor not less than $76 + 10 \log (P)$ dB in a 6.25 kHz band segment, for base and fixed stations;

The Emission limit is:

- -33dBm for measurements up to 1GHz
- -24dBm for measurements above 1 GHz

These Values have been calculated by a formula, which was a result of an inquiry (No. 141765) of the KDB:

12.3 Receiver Settings

	up to 1 GHz	above 1 GHz
Measurement bandwidth	120 kHz	1 MHz
Step width	60 kHz	500 kHz
Dwell time	10ms	
Detector	Peak	Peak

12.4 Climatic values in the lab

Temperature	21°C
Relative Humidity	42%
Air-pressure	1014 hPa



12.5 Test results

12.5.1 30 MHz to 1 GHz Downlink (Bottom – Middle – Top) Subpart H

Bottom: 728MHz; Middle: 737MHz; Top: 746MHz

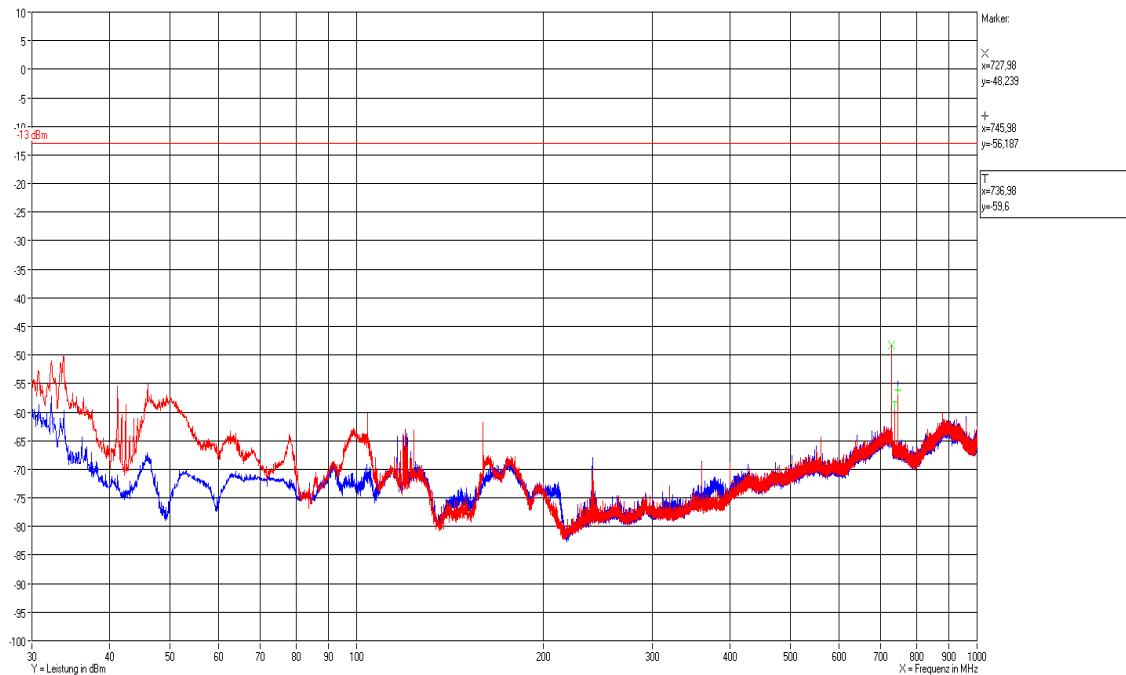

Measurement with Peak detector, BW 120KHz,
Step width 30 kHz, dwell time 10ms

Antenna height: 1.55m; all positions of the turn
table measured with max. hold function

Polarization: **Horizontal** / **Vertical**



12.5.2 30 MHz to 1 GHz Downlink (Bottom – Middle – Top) Subpart F

Bottom: 746MHz; Middle: 751,5MHz; Top: 757MHz

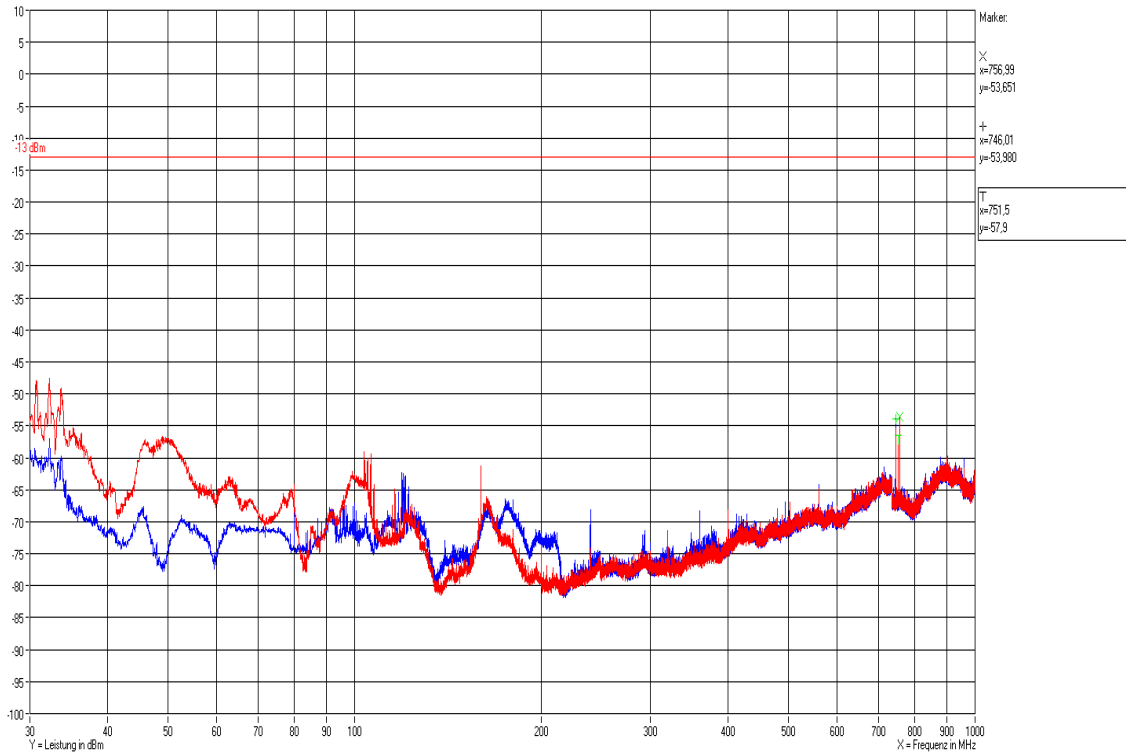

Measurement with Peak detector, BW 120KHz,
Step width 30 kHz, dwell time 10ms

Antenna height: 1.55m; all positions of the turn
table measured with max. hold function

Polarization: Horizontal / Vertical



12.5.3 30 MHz to 1 GHz Downlink (Middle of all paths)

F1: 751.5 MHz; F2: 737 MHz; F3: 2132.5 MHz

Vertikal / Horizontal

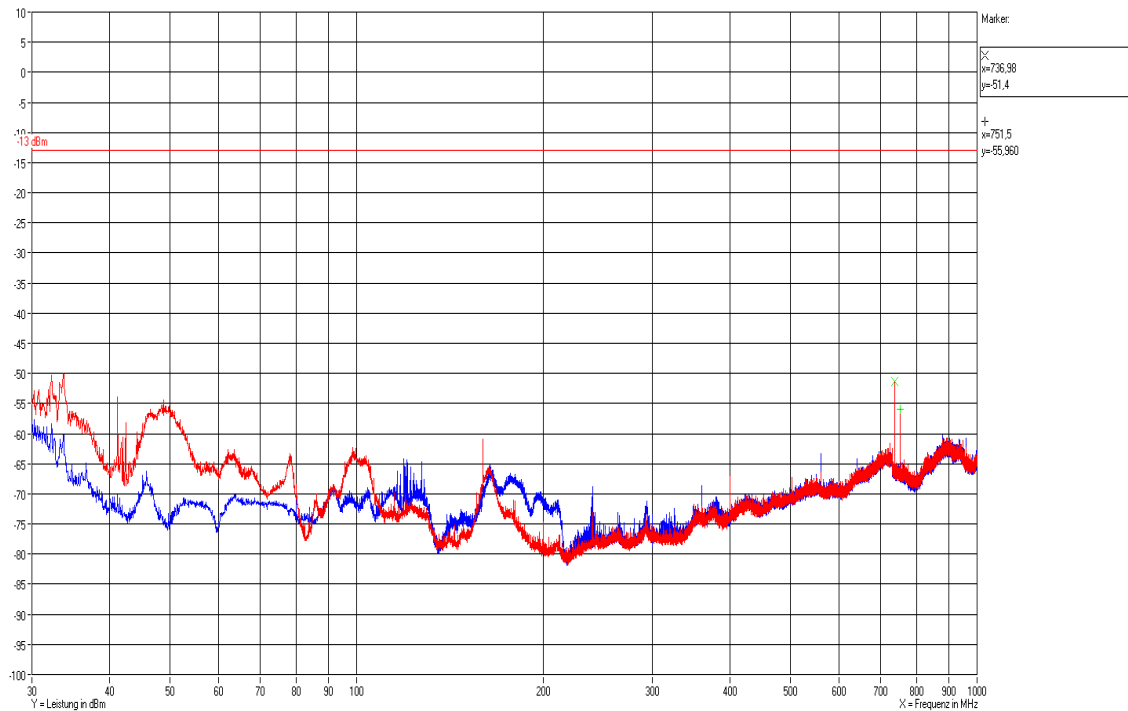

Measurement with Peak detector, BW 120KHz,
Step width 30 kHz, dwell time 10ms

Antenna height: 1.55m; all positions of the turn
table measured with max. hold function

Polarization: Horizontal / Vertical

Test Report No.: 13-238

FCC ID: XS5-M7P17HP

IC ID: 2237E-M7P17HP



BUREAU
VERITAS

12.5.4 1 GHz to 22 GHz Downlink (Bottom – Middle – Top) Subpart H

Bottom: 728MHz; Middle: 737MHz; Top: 746MHz

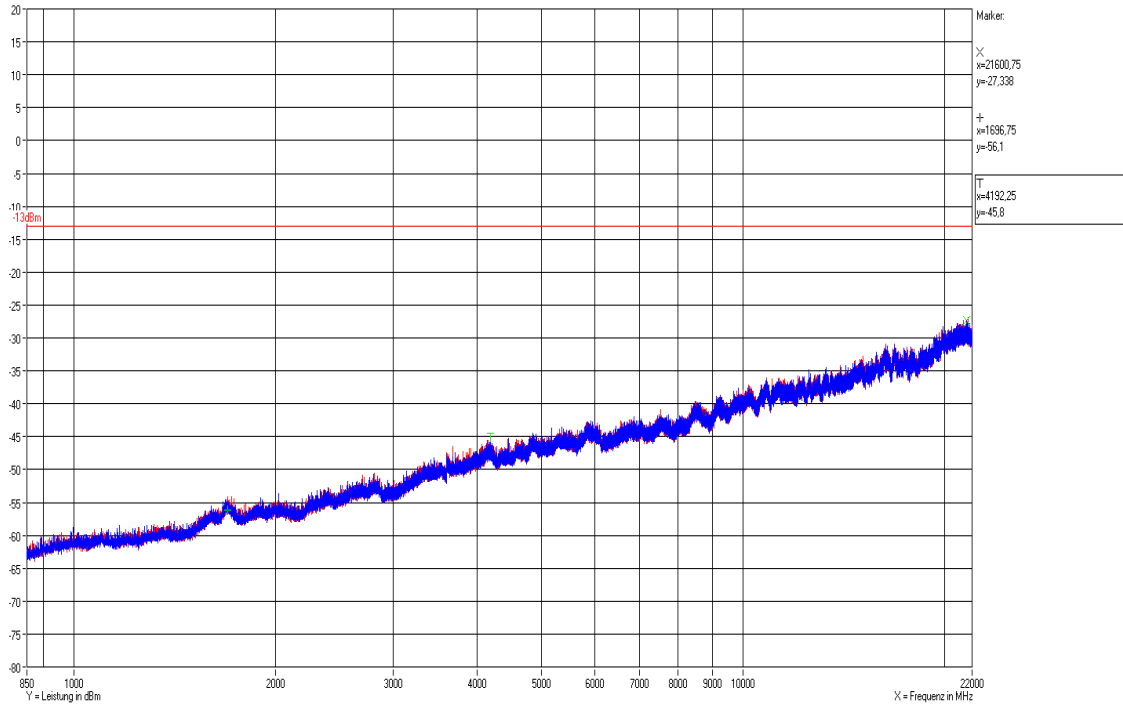

Measurement with Peak detector, BW 1MHz, Step width 0.25 MHz, dwell time 10ms

Antenna height: 1.55m; all positions of the turn table measured with max. hold function

Polarization: **Horizontal** / **Vertical**

No spurious can be measured other than noise and the fundamentals



12.5.5 1 GHz to 22 GHz Downlink (Bottom – Middle – Top) Subpart F

Bottom: 746MHz; Middle: 751,5MHz; Top: 757MHz

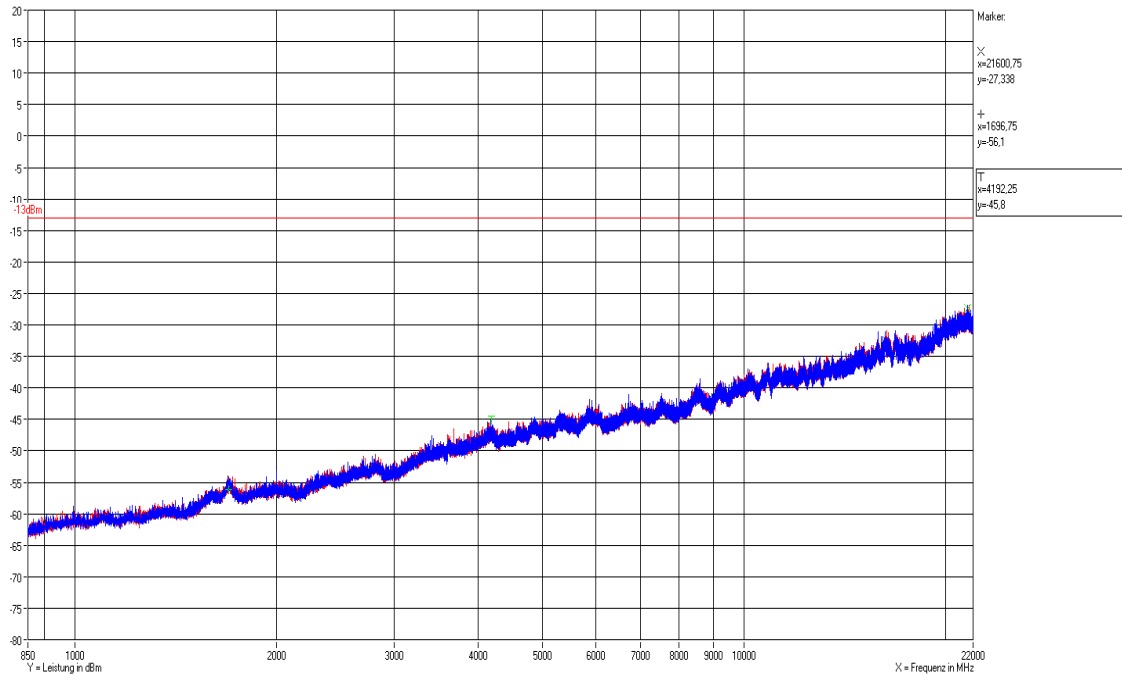

Measurement with Peak detector, BW 1MHz, Step width 0.25 MHz, dwell time 10ms

Antenna height: 1.55m; all positions of the turn table measured with max. hold function

Polarization: **Horizontal** / **Vertical**

No spurious can be measured other than noise and the fundamentals



12.5.6 1 GHz to 22 GHz Downlink (Middle of all paths)

F1: 751.5 MHz; F2: 737 MHz; F3: 2132.5 MHz

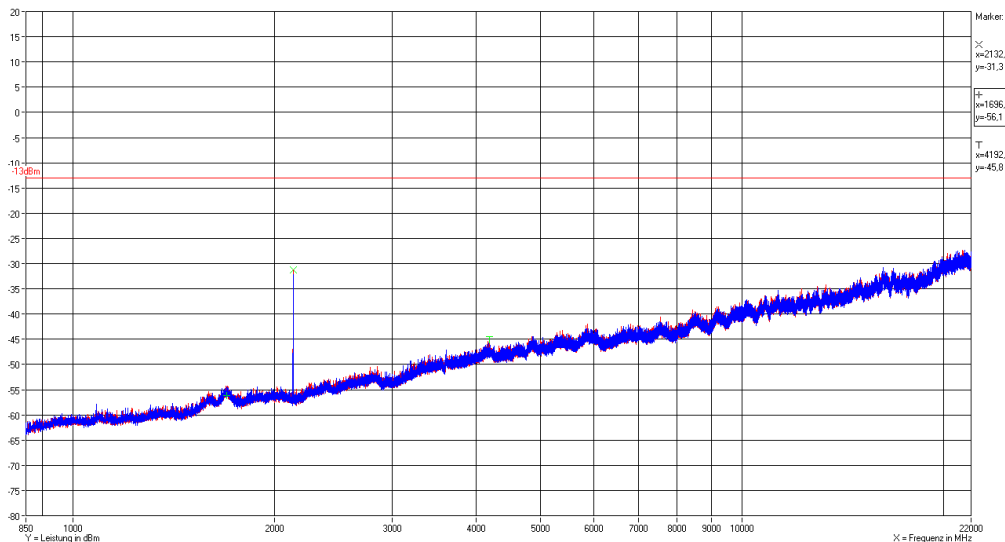

Measurement with Peak detector, BW 1MHz, Step width 0.25 MHz, dwell time 10ms

Antenna height: 1.55m; all positions of the turn table measured with max. hold function

Polarization: **Horizontal** / **Vertical**

No spurious can be measured other than noise and the fundamentals

Za / 03.09.2013

The radiated spurious emission measurements have been passed!

Test Report No.: 13-238

FCC ID: XS5-M7P17HP

IC ID: 2237E-M7P17HP



**BUREAU
VERITAS**

13 History

Revision	Modification	Date	Name
01.00	Initial report	05.09.2013	Zahlmann

******* End of test report *******