

Test Site:  
FCC Test Site No.: 96997  
IC OATS No.: IC3475A-1



BUREAU  
VERITAS

## ECL-EMC Test Report No.: 14-145

Equipment under test: **ION-M7HP/85HP EU 850MHz Path**  
FCC ID: **XS5-M785HPEU**  
IC ID:  
Type of test: **FCC 47 CFR Part 22 Subpart H:2014  
Cellular Radiotelephone Service**

**Measurement Procedures:** 47 CFR Parts 2: 2014 (*Frequency Allocations and Radio Treaty Matters; General Rules and Regulations*), Part 22: 2014 (*Cellular Radiotelephone Service*), ANSI/TIA-603-C (2004), *Land Mobile FM or PM Communications Equipment Measurement and Performance Standards*

**Test result:** **Passed**

Date of issue:	21.07.14	Signature:	
Issue-No.:	01	Author:	
Date of delivery:	14.06.14	Checked:	
Test dates:	03.06. – 21.07.14		
Pages:	51		



**Manufacturer:** ANDREW Wireless Systems GmbH  
Industriering 10

D-86675 Buchdorf

Tel.: +49 (0)9099 69 0

Fax: +49 (0)9099 69 140

**Test Location:** Bureau Veritas Consumer Products Services  
Germany GmbH  
European Compliance Laboratory (ECL)  
Thurn-und-Taxis-Straße 18

D-90411 Nürnberg

Tel.: +49 40 74041 0

Fax: +49 40 74041-2755

**General:**

The purpose of this report is to show compliance to the FCC regulations for licensed devices operating under section 22 of the Code of Federal Regulations title 47.

This report informs about the results of the RF tests, it only refers to the equipment under test. No part of this report may be reproduced in any form, without written permission.



## Table of contents

1	TEST RESULTS SUMMARY .....	5
2	EQUIPMENT UNDER TEST (E.U.T.) .....	6
2.1	DESCRIPTION .....	6
2.1.1	DOWNLINK .....	6
2.1.2	UPLINK .....	6
2.1.3	DESCRIPTION OF EUT .....	7
2.1.4	BLOCK DIAGRAM OF MEASUREMENT REFERENCE POINTS .....	8
2.1.5	DOWNLINK SYSTEM GAIN AND OUTPUT POWER.....	8
3	TEST SITE (ANDREW BUCHDORF) .....	9
3.1	TEST ENVIRONMENT .....	9
3.2	TEST EQUIPMENT .....	9
3.3	INPUT AND OUTPUT LOSSES .....	10
3.4	MEASUREMENT UNCERTAINTY .....	10
4	TEST SITE (BUREAU VERITAS CONSUMER PRODUCTS SERVICES) .....	10
5	RF POWER OUT: §22.913, §2.1046; IC RSS-131 .....	11
5.1	LIMIT.....	11
5.2	TEST METHOD .....	11
5.3	TEST RESULTS.....	12
5.3.1	DOWNLINK.....	13
5.3.1.1	Analog.....	14
5.3.1.2	GSM.....	14
5.3.1.3	EDGE.....	15
5.3.1.4	CDMA .....	15
5.3.1.5	WCDMA.....	16
5.3.1.6	LTE .....	16
5.3.2	UPLINK .....	17
5.4	SUMMARY TEST RESULT.....	17
6	OCCUPIED BANDWIDTH: §2.1049; RSS-GEN .....	18
6.1	LIMIT.....	18
6.2	TEST METHOD .....	18
6.3	TEST RESULTS .....	18
6.3.1	DOWNLINK.....	19
6.3.1.1	Analog.....	20
6.3.1.2	GSM.....	21
6.3.1.3	EDGE.....	22
6.3.1.4	CDMA .....	23
6.3.1.5	WCDMA.....	24
6.3.1.6	LTE .....	25
6.3.2	UPLINK .....	26
6.4	SUMMARY TEST RESULT.....	26



7	SPURIOUS EMISSIONS AT ANTENNA TERMINALS: §22.917, §2.1051; RSS-131, RSS-GEN.....	27
7.1	LIMIT.....	27
7.2	TEST METHOD .....	27
7.3	TEST RESULTS .....	28
7.3.1	DOWNLINK .....	28
7.3.1.1	Analog < 1MHz to band edge.....	30
7.3.1.2	GSM < 1MHz to band edge.....	31
7.3.1.3	EDGE < 1MHz to band edge.....	32
7.3.1.4	CDMA < 1MHz to band edge.....	33
7.3.1.5	WCDMA < 1MHz to band edge.....	34
7.3.1.6	LTE < 1MHz to band edge.....	35
7.3.1.7	Analog > 1MHz to band edge.....	36
7.3.1.8	GSM > 1MHz to band edge.....	36
7.3.1.9	EDGE > 1MHz to band edge.....	37
7.3.1.10	CDMA > 1MHz to band edge.....	37
7.3.1.11	WCDMA > 1MHz to band edge.....	38
7.3.1.12	LTE > 1MHz to band edge.....	38
7.3.2	UPLINK.....	39
7.4	SUMMARY TEST RESULT.....	39
8	OUT OF BAND REJECTION .....	40
8.1	LIMIT.....	40
8.2	TEST METHOD .....	40
8.3	TEST RESULTS .....	40
8.3.1	DOWNLINK.....	41
8.3.2	UPLINK.....	41
8.4	SUMMARY TEST RESULT.....	41
9	FIELD STRENGTH OF SPURIOUS EMISSIONS: §22.917, §2.1053 .....	42
9.1	LIMIT §22.917.....	45
9.2	TEST METHOD ANSI/TIA/EA-603-C .....	46
9.3	CLIMATIC VALUES IN THE LAB.....	46
9.4	TEST RESULTS .....	47
9.4.1	30 MHz TO 1 GHz DOWNLINK (BOTTOM – MIDDLE – TOP) SUBPART H.....	47
9.4.2	30 MHz TO 1 GHz DOWNLINK (MIDDLE OF ALL PATHS) .....	48
9.4.3	1 GHz TO 12.75 GHz DOWNLINK (BOTTOM – MIDDLE – TOP) SUBPART H.....	49
9.4.4	1 GHz TO 12.75 GHz DOWNLINK (MIDDLE OF ALL PATHS).....	50
10	HISTORY.....	51



# 1 Test Results Summary

Name of Test	FCC Para. No.	FCC Method	FCC Spec.	Result
RF Power Output	22.913	2.1046	500 Watts	Complies
Occupied Bandwidth		2.1049	Input/Output	Complies
Spurious Emissions at Antenna Terminals	22.917	2.1051	-13dBm	Complies
Field Strength of Spurious Emissions	22.917	2.1053	-13dBm E.I.R.P	Complies
Frequency Stability	n.a.	2.1055	Must stay in band	NA
Out of Band Rejection	KDB 935210 D02 v02	KDB 935210 D03 v02	KDB 935210 D03 v02	Complies

Name of Test	IC Para. No.	IC Method	Result
RF Power Output	RSS-131	RSS-GEN 4.8	Complies
Occupied Bandwidth	RSS-131	RSS-GEN 4.6.1	Complies
Spurious Emissions at Antenna Terminals	RSS-131	RSS-GEN 4.9	Complies
Field Strength of Spurious Emissions	RSS-131 6.4	RSS-GEN 4.9	Complies
Frequency Stability	RSS-131	RSS-GEN 4.7	NA

Frequency stability is given by: The system gets an electrical analog signal from the BSS which is converted into an analog optical signal, transmitted by the optical links and then reconverted in the Remote Unit into an analog electrical signal. During this process happens no frequency change/modification, so input and output have same frequency what can be seen under clause "Occupied Bandwidth".



## 2 Equipment under test (E.U.T.)

### 2.1 Description

Kind of equipment	ION-M7HP/85HP EU	
Andrew Ident. Number	7693966-0001	
Serial no.(SN)	10	
Revision	00	
Software version and ID	V6.20.0 Id.No. 7684418-20	
Type of modulation and Designator	Analog (F3E (Voice))	<input checked="" type="checkbox"/>
	GSM (GXW)	<input checked="" type="checkbox"/>
	GSM EDGE (G7W)	<input checked="" type="checkbox"/>
	CDMA (F9W)	<input checked="" type="checkbox"/>
	W-CDMA (F9W)	<input checked="" type="checkbox"/>
	LTE (G7D)	<input checked="" type="checkbox"/>
Frequency Translation	F1-F1	<input checked="" type="checkbox"/>
	F1-F2	<input type="checkbox"/>
	N/A	<input type="checkbox"/>
Band Selection	Software	<input type="checkbox"/>
	Duplexer	<input checked="" type="checkbox"/>
	Full band	<input type="checkbox"/>

#### 2.1.1 Downlink

Pass band	Path 869 MHz – 894 MHz
Max. composite output power based on one carrier per path (rated)	45.5 dBm = 35.5 W
System Gain*	12.5 dB @ Pout BTS of 33 dBm

\*see 2.1.6

#### 2.1.2 Uplink

Pass band	Path 824 MHz – 849 MHz
Maximum rated output power	n. a.
System Gain*	n.a.

\*see 2.1.6

Note: The EUT does not transmit over the air in the uplink direction.



### 2.1.3 Description of EUT

Andrew ION-M7HP/85HP EU is a multi-band, multi-operator extension unit. It is used in conjunction with the main unit IONM17HP/19HP. This extension system transports multiple LTE700 channels and 850 MHz wide-band signals.

This Test Report describes only the approval of the 850 MHz Path.

The ION-M7P/85HP EU Repeater system consists of one 700 MHz path and one 850 MHz path with the intended use of simultaneous transmission.

The antenna(s) used with device must be fixed-mounted on permanent structures.



**2.1.4 Block diagram of measurement reference points**

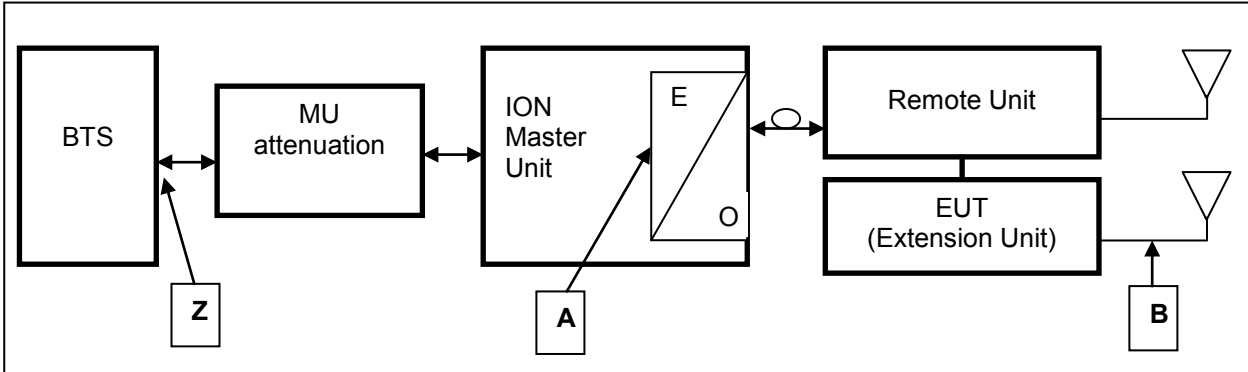

figure 2.1.4-#1 Block diagram of measurement reference points

Extension Unit is the EUT

O/E                      Optical / Electrical converter  
 SRMU                  Sub Rack Master Unit

Reference point A      SRMU              UL output,      DL input  
 Reference point B      Extension Unit   DL output,      UL input  
 Reference point Z      BTS                DL output,      UL input

Downlink:              Measure from reference point A to B

Since a signal generator does not supply a good output signal with +33 or +43dBm, for the downlink measurement the MU Attenuation is not used. That means for downlink measurements the signal generator is connected to measurement point A at the master optical / electrical converter and the analyzer to the measurement point B at the EU.

**2.1.5 Downlink System Gain and Output Power**

System optimized for BTS power (fixed value)  <b>Z</b>	MU Attenuation (manual leveling)	Maximum rated input power at the MU OTRX (fixed value)  <b>A</b>	EU Gain (fixed value)  <b>A to B</b>	Maximum rated output power at EU Antenna port (fixed value)  <b>B</b>
<b>+33 dBm</b>	<b>27.5 dB</b>	<b>+5.5 dBm</b>	<b>+40 dB</b>	<b>+45.5 dBm</b> @ 1 carrier
<b>System Gain Z to B</b>	<b>+12.5 dB</b>			
<b>+43 dBm</b>	<b>37.5 dB</b>	<b>+5.5 dBm</b>	<b>+40 dB</b>	<b>+45.5 dBm</b> @ 1 carrier
<b>System Gain Z to B</b>	<b>+2.5 dB</b>			

table 2.1.5-#1 Equipment under test (E.U.T.) Description Downlink System Gain and Output Power



### 3 Test site (Andrew Buchdorf)

#### 3.1 Test environment

All tests were performed under the following environmental conditions:

Condition	Minimum value	Maximum value
Barometric pressure	86 kPa	106 kPa
Temperature	15°C	30°C
Relative Humidity	20 %	75 %
Power supply range	±5% of rated voltages	

#### 3.2 Test equipment

ANDREW Inv. No.	Test equipment	Type	Manufacturer	Serial No.	Calibration
9102	Network Analyzer	ZVB 14	R&S	100118	08/14
9054	Spectrum Analyzer	FSV13	R&S	100859	12/14
9233	Signal Generator	SMBV100A	R&S	257777	06/15
8849	Signal Generator	SMU200A	R&S	101732	04/15
8671	Power Meter	E4418B	Agilent	GB39513094	06/15
8672	Power Sensor	E9300H	Agilent	US41090179	06/15
7336	Power Attenuator	768-20	Narda	04904	CIU
7119	Divider	2way	Mikom	3512	CIU
7408	RF-Cable	2,0m; N-N	Andrew	---	CIU
7409	RF-Cable	2,0m; N-N	Andrew	---	CIU
7410	RF-Cable	1,0m; N-N	Andrew	---	CIU
7411	RF-Cable	2,0m; N-N	Andrew	---	CIU
7373	RF-Cable	Multiflex141	Andrew	---	CIU
7374	RF-Cable	Multiflex141	Andrew	---	CIU
7437	RF-Cable	Multiflex141	Andrew	---	CIU
7438	RF-Cable	Multiflex141	Andrew	---	CIU
7439	RF-Cable	Multiflex141	Andrew	---	CIU
7443	RF-Cable	Multiflex141	Andrew	---	CIU
7444	RF-Cable	Multiflex141	Andrew	---	CIU
7445	RF-Cable	Multiflex141	Andrew	---	CIU
7446	RF-Cable	Multiflex141	Andrew	---	CIU
7447	RF-Cable	Multiflex141	Andrew	---	CIU
7448	RF-Cable	Multiflex141	Andrew	---	CIU
7449	RF-Cable	Multiflex141	Andrew	---	CIU
7450	RF-Cable	Multiflex141	Andrew	---	CIU
7440	RF-Cable	RG-223 0.8m	Andrew	---	CIU
7441	RF-Cable	RG-223 0.8m	Andrew	---	CIU
7460	Notch filter	WRCTF869/894-867/896-60/12+9EE	Wainwright Instruments	1	CIU
7368	Matrix	Extended Version	Andrew	---	CIU

CIU = Calibrate in use



### 3.3 Input and output losses

All recorded power levels should be referenced to the input and output connectors of the repeater, unless explicitly stated otherwise.

The test equipment used in this test has to be calibrated, so that the functionality is also checked.

All cables, attenuators, splitter, isolator, circulator and combiner etc. must be measured before testing and used for compensation during testing.

### 3.4 Measurement uncertainty

The extended measurement uncertainty corresponds to the measurement results from the standard measurement uncertainty multiplied by the coverage factor  $k=2$ . The true value is located in the corresponding interval with a probability of 95 %.

## 4 Test site (Bureau Veritas Consumer Products Services)

FCC Test site: 96997  
IC OATS: 2237E

See relevant dates under section 9.



## 5 RF Power Out: §22.913, §2.1046; IC RSS-131

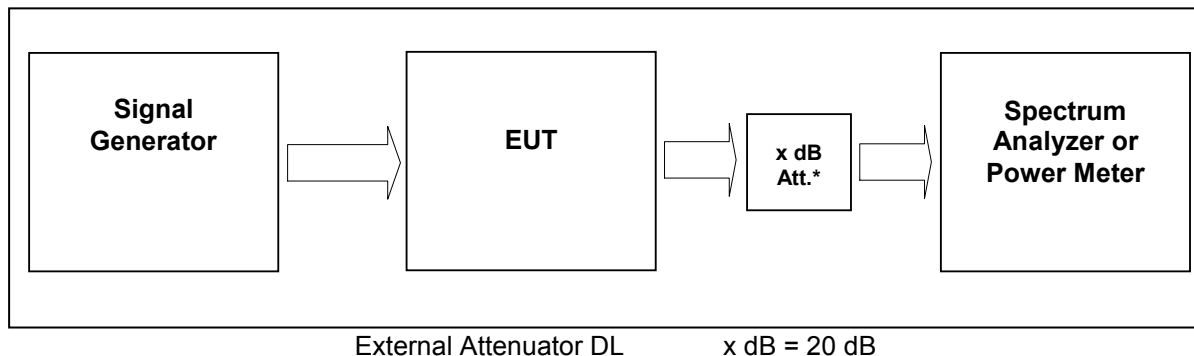

figure 5-#1 Test setup: RF Power Out: §22.913, §2.1046; IC RSS-131

Measurement uncertainty	± 0,38 dB
Test equipment used	9054; 9233; 7336; 7408; 7449; 7444; 7374; 7368

### 5.1 Limit

Minimum standard:

Para. No.22.913

The effective radiated power (ERP) of transmitters in the Cellular Radiotelephone Service must not exceed the limits in this section.

(a) *Maximum ERP.* In general, the effective radiated power (ERP) of base transmitters and cellular repeaters must not exceed 500 Watts. However, for those systems operating in areas more than 72 km (45 miles) from international borders that:

(1) Are located in counties with population densities of 100 persons or fewer per square mile, based upon the most recently available population statistics from the Bureau of the Census; or,

(2) Extend coverage on a secondary basis into cellular unserved areas, as those areas are defined in § 22.949, the ERP of base transmitters and cellular repeaters of such systems must not exceed 1000 Watts. The ERP of mobile transmitters and auxiliary test transmitters must not exceed 7 Watts.

### 5.2 Test method

§ 2.1046 Measurements required: RF power output.

(a) For transmitters other than single sideband, independent sideband and controlled carrier radiotelephone, power output shall be measured at the RF output terminals when the transmitter is adjusted in accordance with the tune-up procedure to give the values of current and voltage on the circuit elements specified in § 2.1033(c)(8). The electrical characteristics of the radio frequency load attached to the output terminals when this test is made shall be stated.

(c) For measurements conducted pursuant to paragraphs (a) and (b) of this section, all calculations and methods used by the applicant for determining carrier power or peak envelope power, as appropriate, on the basis of measured power in the radio frequency load attached to the transmitter output terminals shall be shown. Under the test conditions specified, no components of the emission spectrum shall exceed the limits specified in the applicable rule parts as necessary for meeting occupied bandwidth or emission limitations



### 5.3 Test Results

Detector RMS.

**Test signal Analog:**

FM signal with 3.0 kHz deviation and 2.5 kHz rate and sine waveform

**Test signal GSM:**

Signal waveform with GMSK modulation in all time slots according to 3GPP TS45.004

**Test signal GSM EDGE:**

Signal waveform with 8-PSK modulation in all time slots according to 3GPP TS45.004

**Test signal CDMA:**

Signal waveform according to table 6.2-1 of standard specification 3GPP2 C.p0051-0 v1.0 16.February 2006 pilot, sync, paging, 37 traffics, which is equal to the table 6.5.2.1 of 3GPP2 C.S0010-C v2.0 24.February 2006.

**Test signal WCDMA:**

Signal waveform according to Test Model 1 of standard specification 3GPP TS25.141. Signal modulated with a combination of PCCPCH, SCCPCH and Dedicated Physical Channels specified as test model 1 64 DPCH.

**Test signal LTE:**

Signal waveform according to Test Model 1.1, E-TM1.1, clause 6.1.1.1-1, table 6.1.1.1-1 of standard specification 3GPP TS 36.141 V9.3.0 (2010-03).



**5.3.1 Downlink**

Modulation	Measured at		RBW VBW Span	RF Power [dBm]	RF Power [W]	Plot -
Analog	Middle	881.5 MHz	0.1MHz 0.3MHz 1.5MHz	45.5	35.5	5.3.1.1 #1
GSM	Middle	881.5 MHz	1MHz 3MHz 10MHz	45.5	35.5	5.3.1.2 #1
EDGE	Middle	881.5 MHz	1MHz 3MHz 10MHz	45.5	35.5	5.3.1.3 #1
CDMA	Middle	881.5 MHz	3MHz 10MHz 15MHz	45.5	35.5	5.3.1.4 #1
WCDMA	Middle	881.5 MHz	10MHz 10MHz 50MHz	45.0	31.6	5.3.1.5 #1
LTE	Middle	881.5 MHz	3MHz 10MHz 15MHz	45.5	35.5	5.3.1.6 #1
Maximum output power = 45.5 dBm = 28.2 W						
Limit Maximum output power = 57 dBm = 500 W						

table 5.3.1-#1 RF Power Out: §22.913, §2.1046; IC RSS-131 Test Results Downlink

The max RF Power out is 45.5 dBm, so the maximum antenna gain (x) can be calculated as follow:

**Limit = 500W (erp) = 57 dBm**  
 $57 \text{ dBm} > 45.5 \text{ dBm} + x$   
**11.5 dBd = 13.65 dBi > x**

=> The antenna that will be used for the complete system have to have a gain lower than 13.65 dBi, relative to a dipol.

Modulation	Pin / dBm (Ref. point B)
Analog	5.3
GSM	5.4
EDGE	5.4
CDMA	5.3
WCDMA	4.6
LTE	5.0

table 5.3.1-#2 RF Power Out: §22.913, §2.1046; IC RSS-131 Test Results Downlink Input power



### 5.3.1.1 Analog

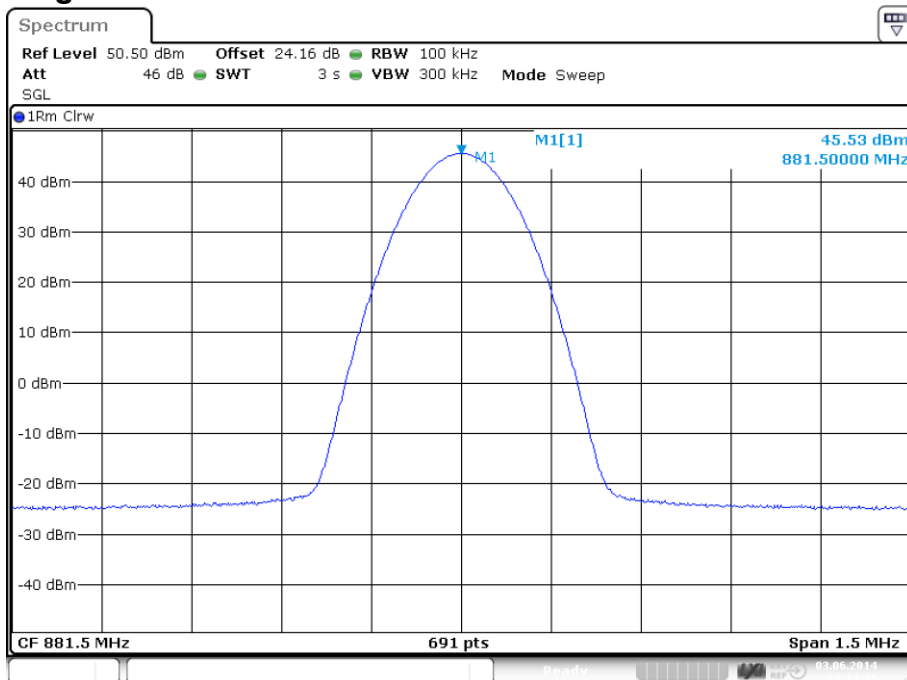

Date: 3.JUN.2014 08:14:31

plot 5.3.1.1-#1 RF Power Out: §22.913, §2.1046; IC RSS-131; Test Results; Downlink; Analog Middle

### 5.3.1.2 GSM

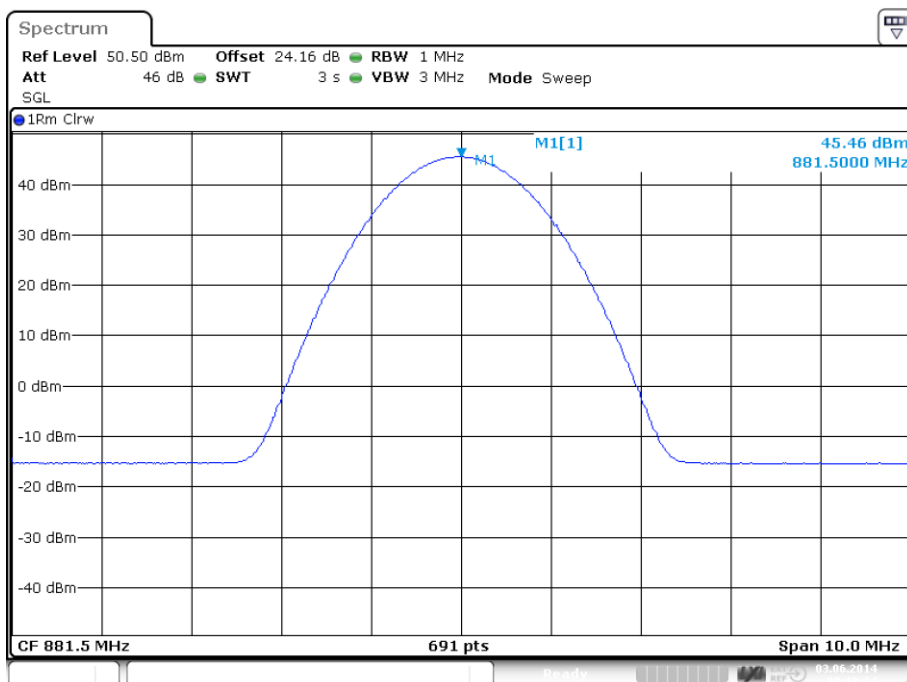

Date: 3.JUN.2014 08:19:34

plot 5.3.1.2-#1 RF Power Out: §22.913, §2.1046; IC RSS-131; Test Results; Downlink; GSM Middle



### 5.3.1.3 EDGE

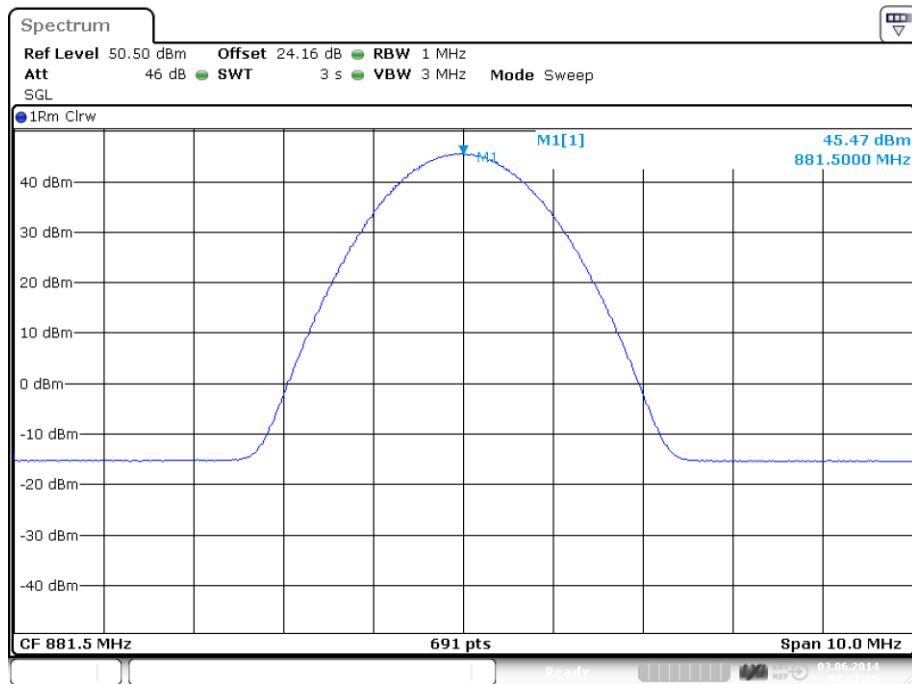

Date: 3.JUN.2014 08:17:15

plot 5.3.1.3-#1 RF Power Out: §22.913, §2.1046; IC RSS-131; Test Results; Downlink; EDGE Middle

### 5.3.1.4 CDMA

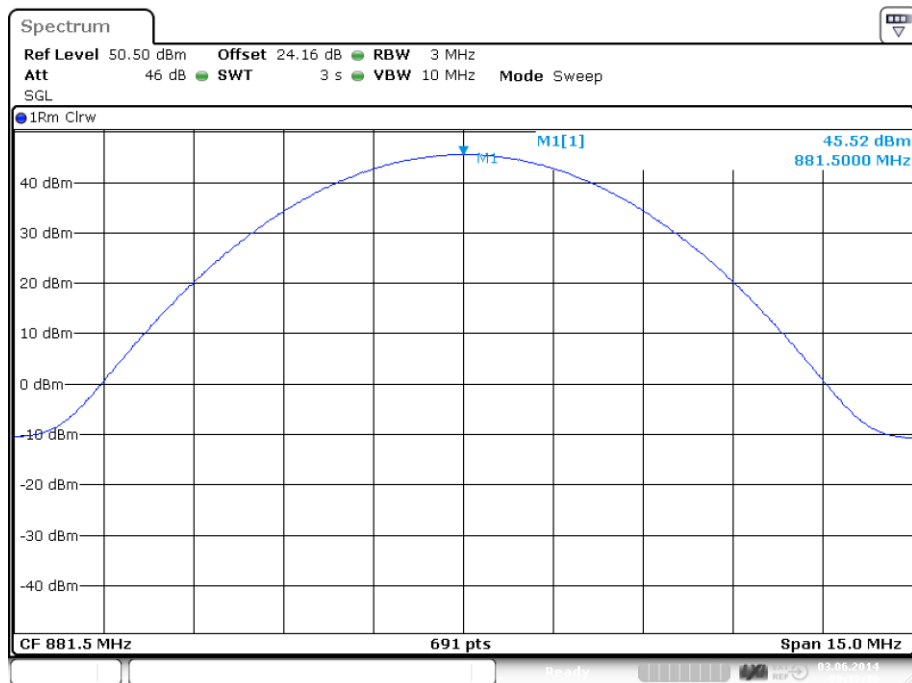

Date: 3.JUN.2014 08:12:30

plot 5.3.1.4-#1 RF Power Out: §22.913, §2.1046; IC RSS-131; Test Results; Downlink; CDMA Middle



### 5.3.1.5 WCDMA

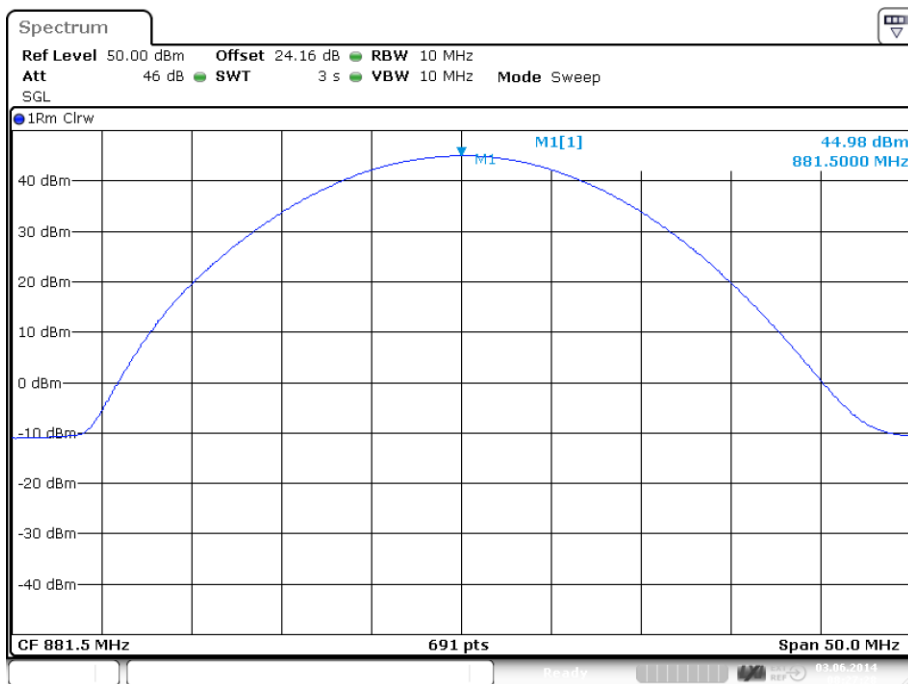

Date: 3.JUN.2014 08:27:28

plot 5.3.1.5-#1 RF Power Out: §22.913, §2.1046; IC RSS-131; Test Results; Downlink; WCDMA Middle

### 5.3.1.6 LTE

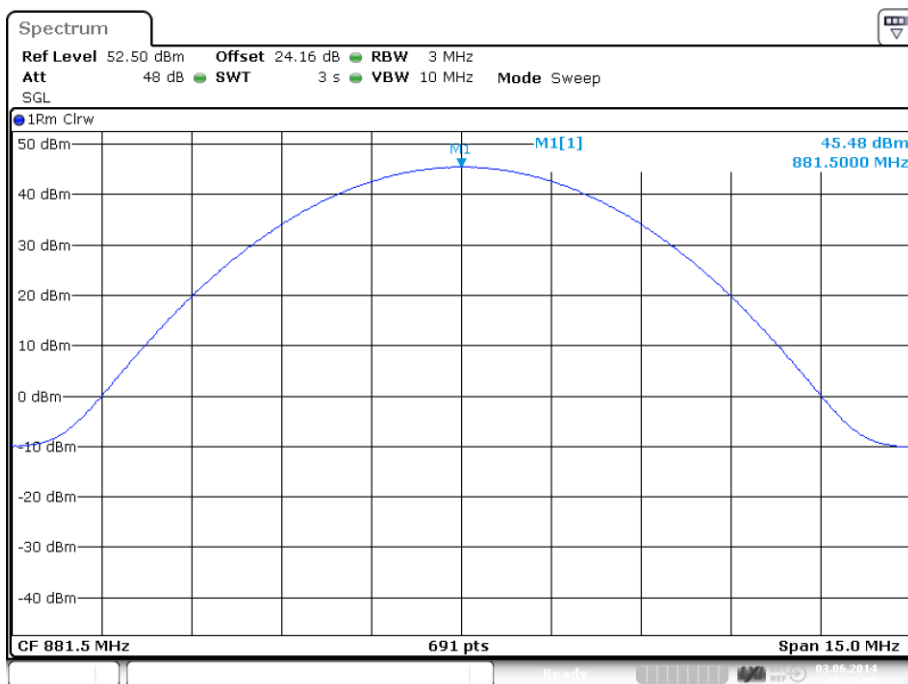

Date: 3.JUN.2014 08:25:06

plot 5.3.1.6-#1 RF Power Out: §22.913, §2.1046; IC RSS-131; Test Results; Downlink; LTE Middle





### 5.3.2 Uplink

n.a.

Note: The EUT does not transmit over the air in the uplink direction.

### 5.4 Summary test result

Test result	complies, according the plots above
Tested by:	M. Leinfelder
Date:	03.06.2014



## 6 Occupied Bandwidth: §2.1049; RSS-GEN

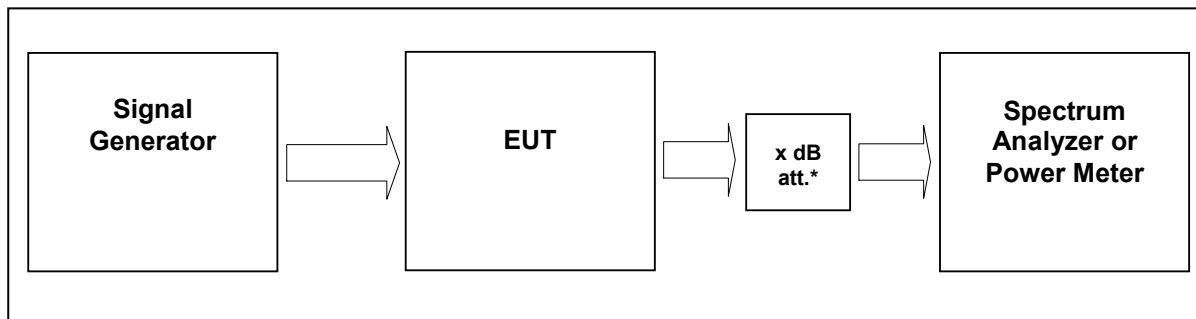

External Attenuator DL      x dB = 20 dB  
 figure 6-#1 Test setup: Occupied Bandwidth: §2.1049; RSS-GEN

Measurement uncertainty	± 0,38 dB
Test equipment used	9054; 9233; 7336; 7408; 7449; 7444; 7374; 7368

### 6.1 Limit

The spectral shape of the output should look similar to input for all modulations.

### 6.2 Test method

Para. No.2.1049

The occupied bandwidth, that is the frequency bandwidth such that, below its lower and above its upper frequency limits, the mean powers radiated are each equal to 0.5 percent of the total mean power radiated by a given emission shall be measured under the following conditions as applicable:

### 6.3 Test results

For composite power measurements: Detector RMS.



**6.3.1 Downlink**

Modulation	Measured at		RBW VBW Span	Occupied Bandwidth	Plot #
Analog	Middle	881,5 MHz	1 kHz 10 kHz 125 kHz	8.68 kHz	6.3.1.1 #1, #2
GSM	Middle	881,5 MHz	3 kHz 30 kHz 1 MHz	0.19 MHz	6.3.1.2 #1, #2
EDGE	Middle	881,5 MHz	3 kHz 30 kHz 1 MHz	0.19 MHz	6.3.1.3 #1, #2
CDMA	Middle	881,5 MHz	30 kHz 300 kHz 5 MHz	1.18 MHz	6.3.1.4 #1, #2
WCDMA	Middle	881,5 MHz	100 kHz 1 MHz 10 MHz	3.8 MHz	6.3.1.5 #1, #2
LTE	Middle	881,5 MHz	30 kHz 300 kHz 5 MHz	1.05 MHz	6.3.1.6 #1, #2

table 6.3-#1 Occupied Bandwidth: §2.1049; RSS-GEN Test results



### 6.3.1.1 Analog

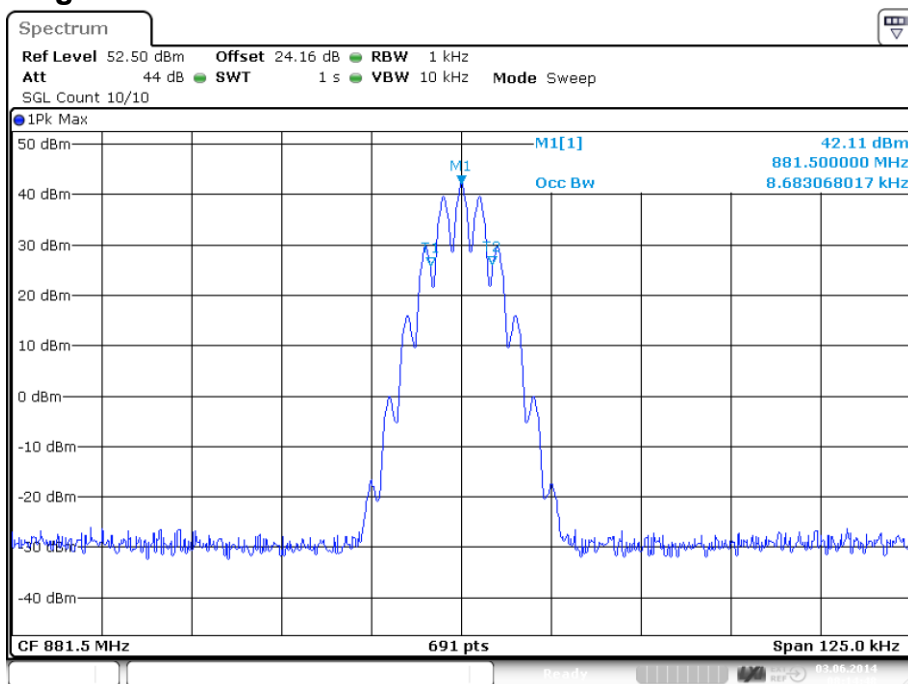

Date: 3.JUN.2014 08:14:49

plot 6.3.1.1-#1 Occupied Bandwidth: \$2.1049; RSS-GEN; Test results; Downlink; Analog Output

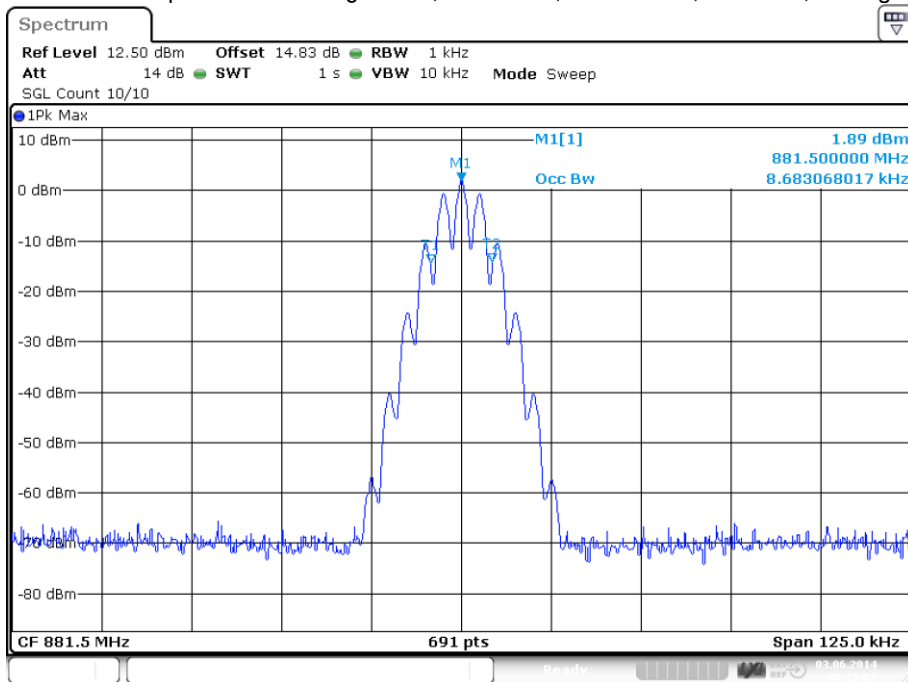

Date: 3.JUN.2014 08:15:02

plot 6.3.1.1-#2 Occupied Bandwidth: \$2.1049; RSS-GEN; Test results; Downlink; Analog Input



6.3.1.2 GSM

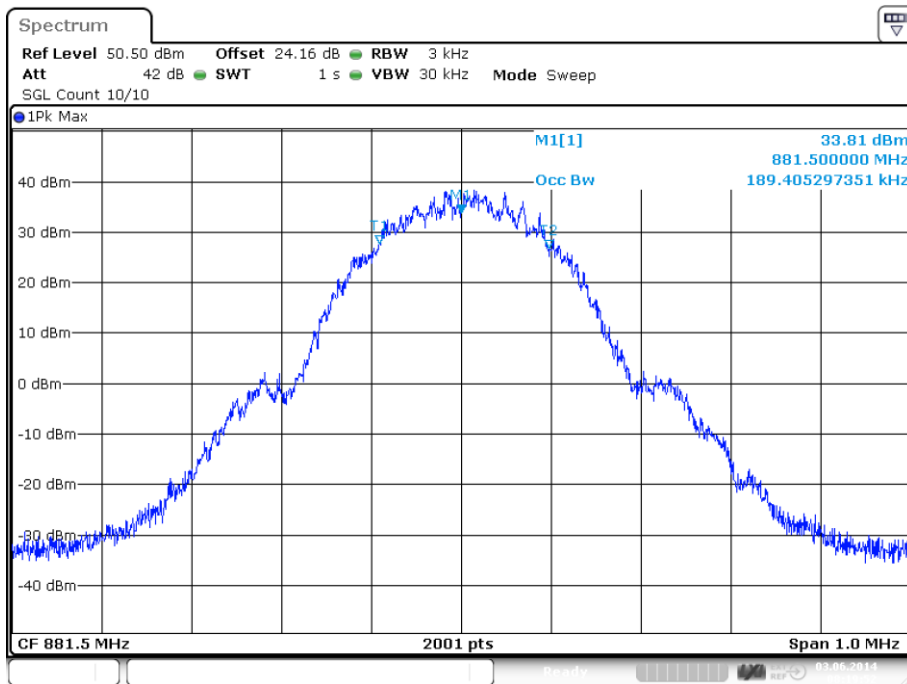

Date: 3.JUN.2014 08:19:52

plot 6.3.1.2-#1 Occupied Bandwidth: §2.1049; RSS-GEN; Test results; Downlink; GSM Output

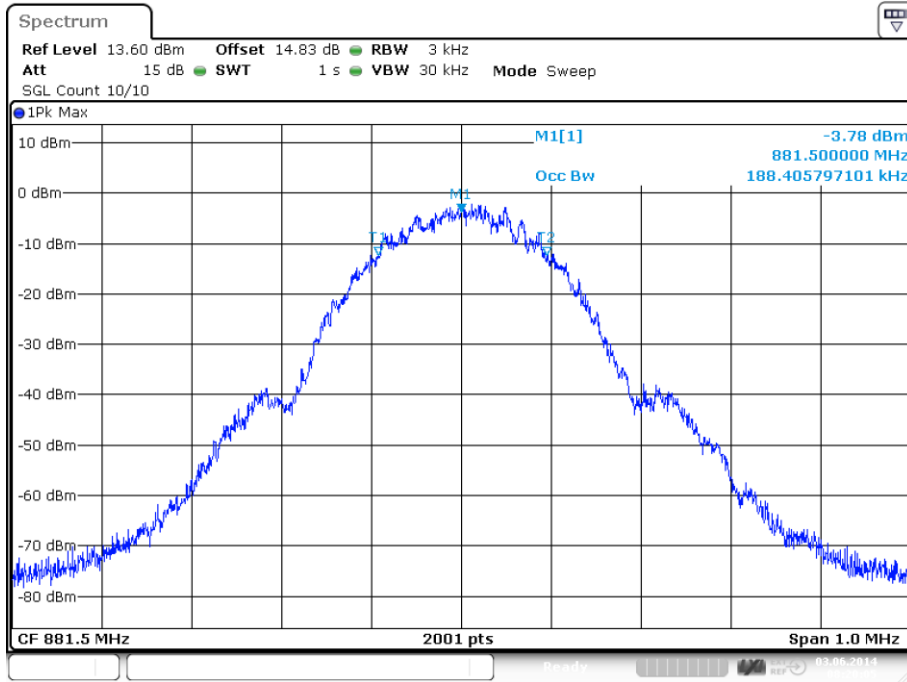

Date: 3.JUN.2014 08:20:05

plot 6.3.1.2-#2 Occupied Bandwidth: §2.1049; RSS-GEN; Test results; Downlink; GSM Input



6.3.1.3 EDGE

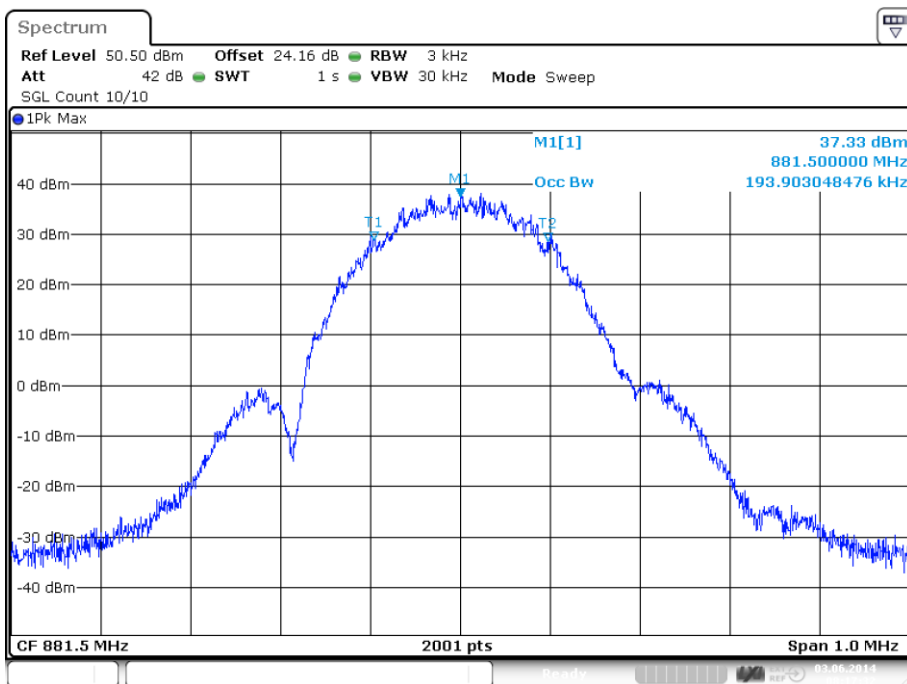

plot 6.3.1.3-#1 Occupied Bandwidth: \$2.1049; RSS-GEN; Test results; Downlink; EDGE Output

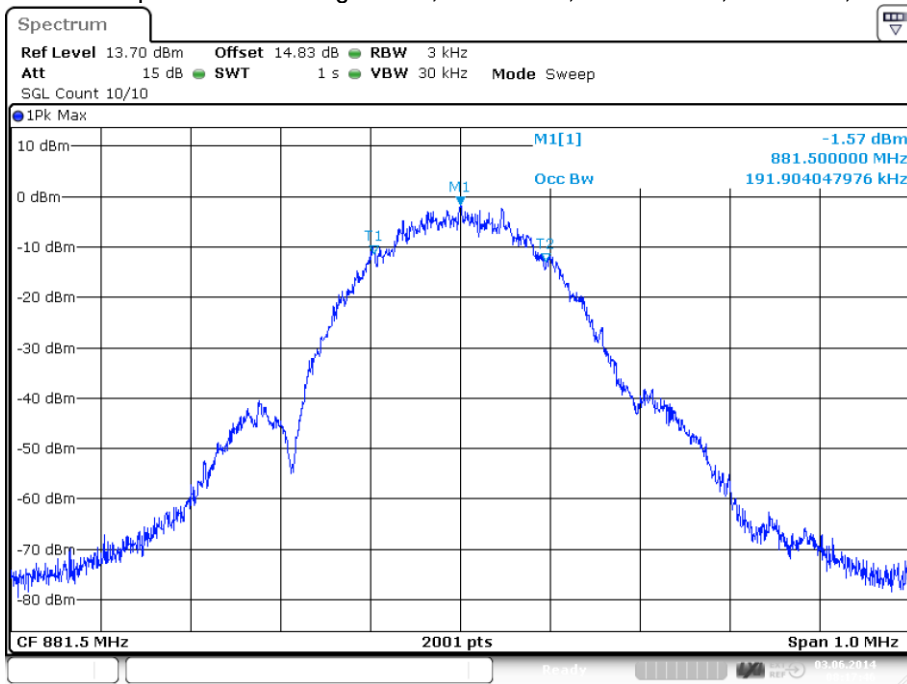

plot 6.3.1.3-#2 Occupied Bandwidth: \$2.1049; RSS-GEN; Test results; Downlink; EDGE Input



6.3.1.4 CDMA

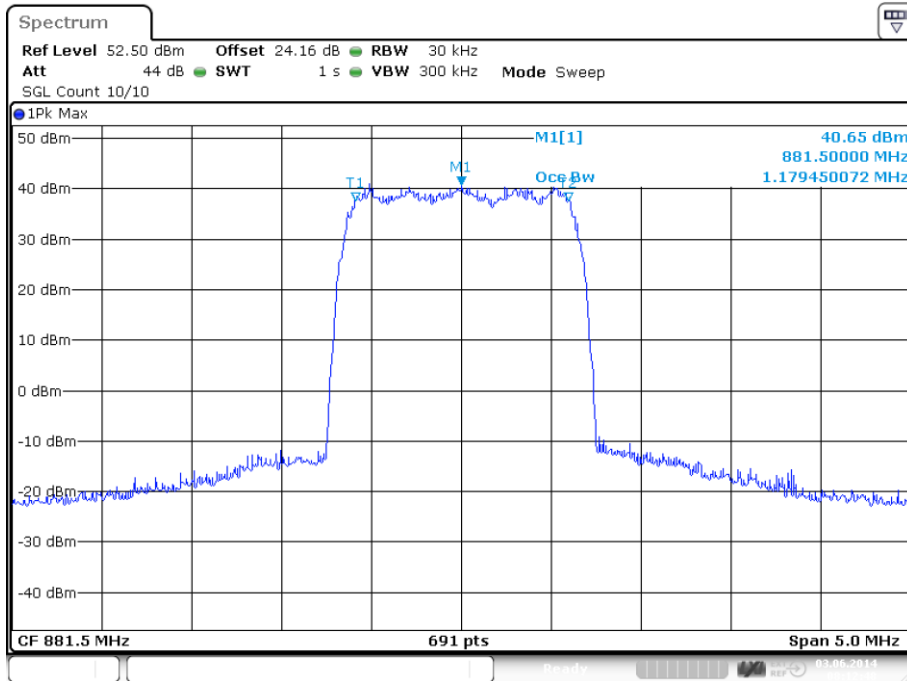

plot 6.3.1.4-#1 Occupied Bandwidth: \$2.1049; RSS-GEN; Test results; Downlink; CDMA Output

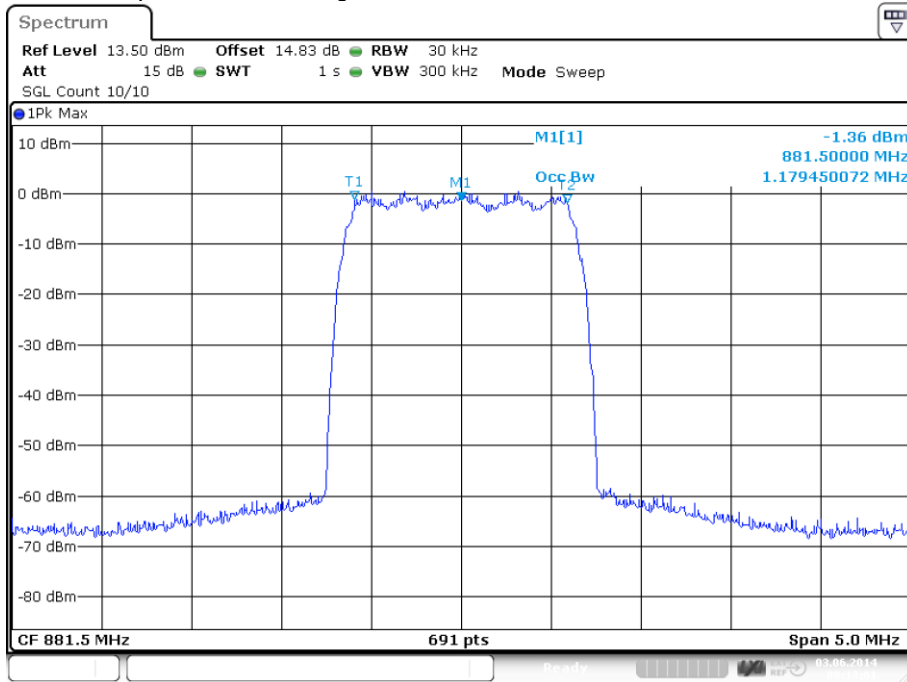

plot 6.3.1.4-#2 Occupied Bandwidth: \$2.1049; RSS-GEN; Test results; Downlink; CDMA Input



6.3.1.5 WCDMA

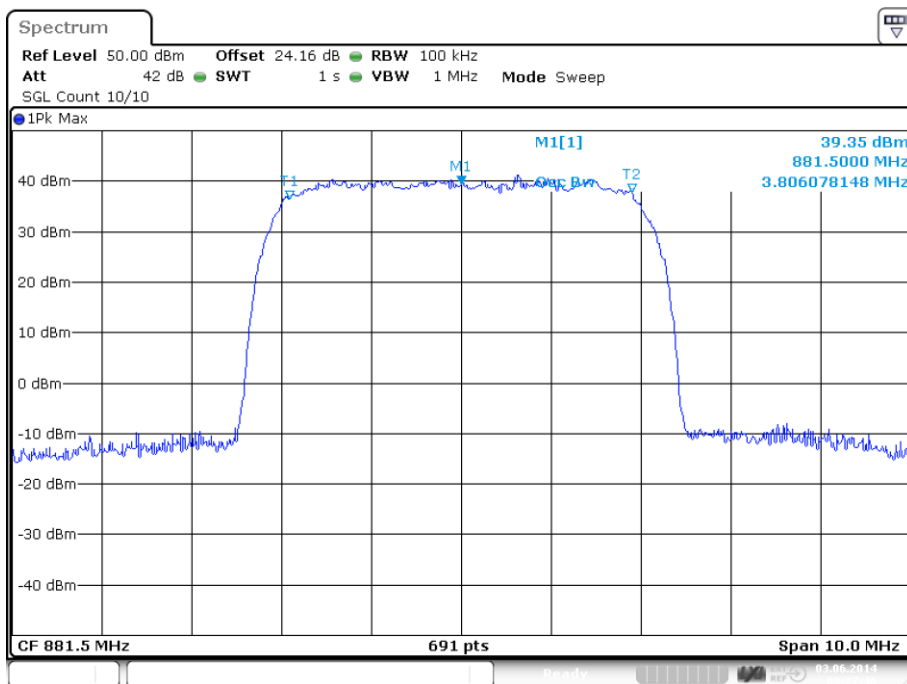

plot 6.3.1.5-#1 Occupied Bandwidth: §2.1049; RSS-GEN; Test results; Downlink; WCDMA Output

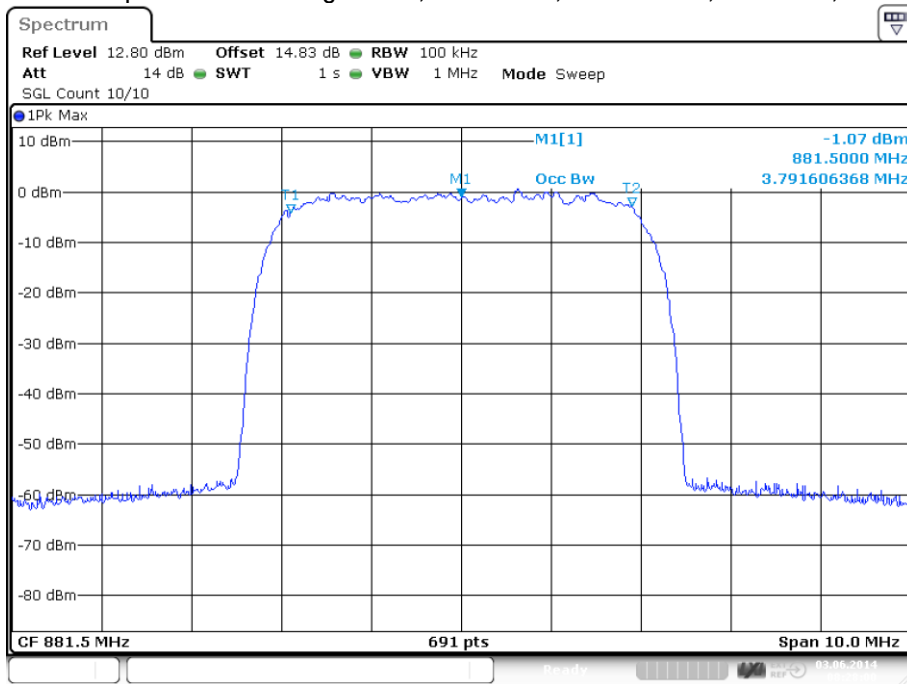

plot 6.3.1.5-#2 Occupied Bandwidth: §2.1049; RSS-GEN; Test results; Downlink; WCDMA Input





6.3.1.6 LTE

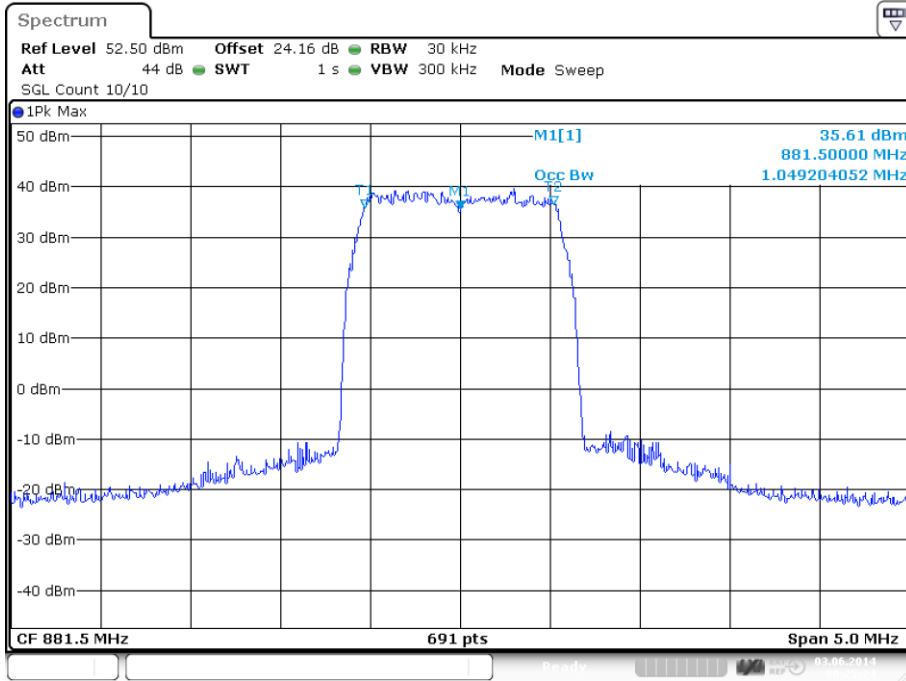

plot 6.3.1.6-#1 Occupied Bandwidth: \$2.1049; RSS-GEN; Test results; Downlink; LTE Output

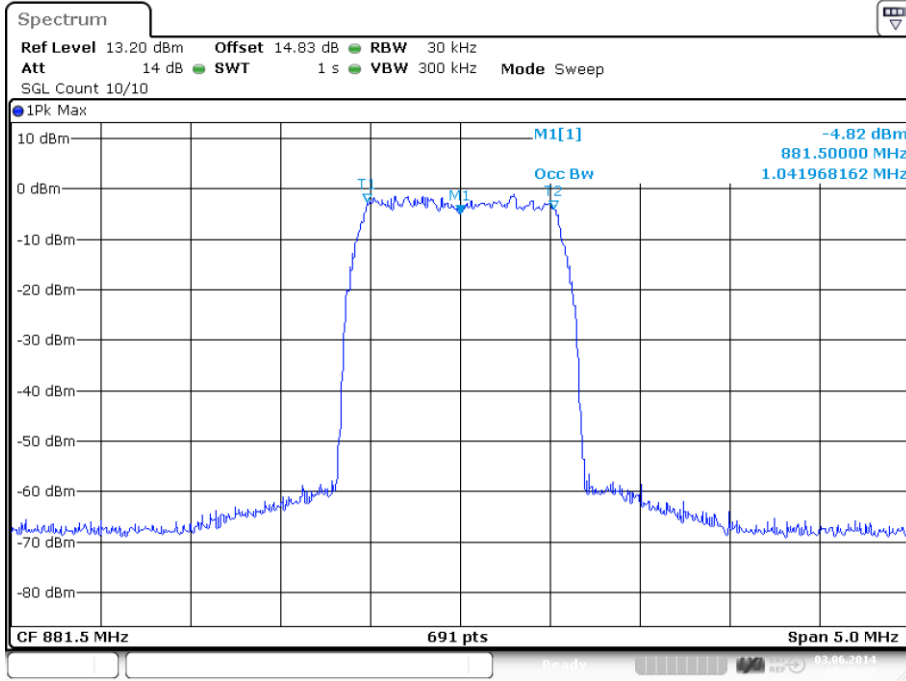

plot 6.3.1.6-#2 Occupied Bandwidth: \$2.1049; RSS-GEN; Test results; Downlink; LTE Input



### 6.3.2 Uplink

n.a.

Note: The EUT does not transmit over the air in the uplink direction.

### 6.4 Summary test result

Test result	complies, according the plots above
Tested by:	M. Leinfelder
Date:	03.06.2014

## 7 Spurious Emissions at Antenna Terminals: §22.917, §2.1051; RSS-131, RSS-GEN

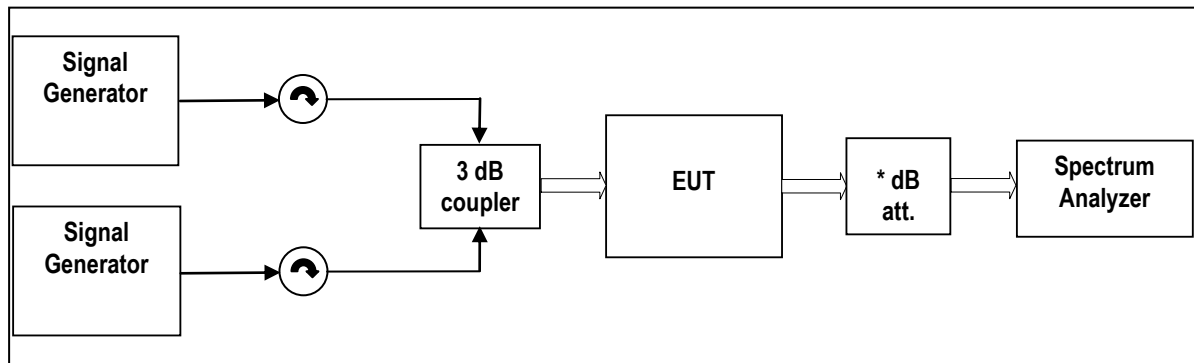

External Attenuator DL x dB = 20 dB

figure 7-#1 Test setup: Spurious Emissions at Antenna Terminals: §22.917, §2.1051; RSS-131, RSS-GEN

Measurement uncertainty	± 0,54 dB ± 1,2 dB ± 1,5 dB	9 kHz to 3 GHz 3 GHz to 7 GHz 7 GHz to 26 GHz
Test equipment used	9054; 9233;8849; 7119; 7447; 7448; 7443; 7336; 7408; 7449; 7444; 7374, 7460; 7368	

### 7.1 Limit

Minimum standard:

Para. No.22.917

(a) *Out of band emissions.* The power of any emission outside of the authorized operating frequency ranges must be attenuated below the transmitting power (P) by a factor of at least  $43 + 10 \log(P)$  dB.

(b) *Measurement procedure.* Compliance with these rules is based on the use of measurement instrumentation employing a resolution bandwidth of 100 kHz or greater. In the 1 MHz bands immediately outside and adjacent to the frequency block a resolution bandwidth of at least one percent of the emission bandwidth of the fundamental emission of the transmitter may be employed. A narrower resolution bandwidth is permitted in all cases to improve measurement accuracy provided the measured power is integrated over the full required measurement bandwidth (*i.e.* 100 kHz or 1 percent of emission bandwidth, as specified). The emission bandwidth is defined as the width of the signal between two points, one below the carrier center frequency and one above the carrier center frequency, outside of which all emissions are attenuated at least 26 dB below the transmitter power.

### 7.2 Test method

Para. No 2.1051 Measurements required: Spurious emissions at antenna terminals.

The radio frequency voltage or powers generated within the equipment and appearing on a spurious frequency shall be checked at the equipment output terminals when properly loaded with a suitable artificial antenna. Curves or equivalent data shall show the magnitude of each harmonic and other spurious emission that can be detected when the equipment is operated under the conditions specified in § 2.1049 as appropriate. The magnitude of spurious emissions which are attenuated more than 20 dB below the permissible value need not be specified.

[39 FR 5919, Feb. 15, 1974. Redesignated and amended at 63 FR 36599, July 7, 1998]



**7.3 Test results**

**7.3.1 Downlink**

**<1MHz from Band Edge**

Detector: RMS.

Modulation	Measured at Band Edge	Carriers	RBW VBW Span Sweep points	Max. level (dBm)	Plot -
Analog	Lower Edge Upper Edge	869.0125 MHz 869.0375 MHz 893.9625 MHz 893.9875 MHz	0.3kHz 3kHz 1.1MHz	-23.4	7.3.1.1 #1 #2
GSM	Lower Edge Upper Edge	869.4 MHz 869.6 MHz 893.4 MHz 893.6 MHz	3kHz 30kHz 2MHz	-31.3	7.3.1.2 #1 #2
EDGE	Lower Edge Upper Edge	869.4 MHz 869.6 MHz 893.4 MHz 893.6 MHz	3kHz 30kHz 2MHz	-30.8	7.3.1.3 #1 #2
CDMA	Lower Edge Upper Edge	869.775 MHz 871.025 MHz 891.975 MHz 893.225 MHz	30kHz 300kHz 6MHz	-22.6	7.3.1.4 #1 #2
WCDMA	Lower Edge Upper Edge	871.6 MHz 876.6 MHz 886.4 MHz 891.4 MHz	100kHz 1MHz 15MHz	-23.0	7.3.1.5 #1 #2
LTE	Lower Edge Upper Edge	869.7 MHz 872.1 MHz 891.9 MHz 893.3 MHz	30kHz 300kHz 6MHz	-23.5	7.3.1.6 #1 #2

table 7.3-#1 Spurious Emissions at Antenna Terminals: §22.917, §2.1051; RSS-131, RSS-GEN Test results <1MHz from Band Edge



>1MHz from Band Edge

Detector: RMS.

Modulation	Carrier	RBW VBW Span	Max. level (dBm)	Plot -
Analog	881,5 MHz	1MHz 3MHz 30MHz – 10GHz	-21.1	7.3.1.7 #1
GSM	881,5 MHz	1MHz 3MHz 30MHz – 10GHz	-21.5	7.3.1.8 #1
EDGE	881,5 MHz	1MHz 3MHz 30MHz – 10GHz	-21.5	7.3.1.9 #1
CDMA	881,5 MHz	1MHz 3MHz 30MHz – 10GHz	-21.1	7.3.1.10 #1
WCDMA	881,5 MHz	1MHz 3MHz 30MHz – 10GHz	-21.2	7.3.1.11 #1
LTE	881,5 MHz	1MHz 3MHz 30MHz – 10GHz	-21.2	7.3.1.12 #1

table 7.3-#2 Spurious Emissions at Antenna Terminals: §22.917, §2.1051; RSS-131, RSS-GEN Test results <1MHz from Band Edge



7.3.1.1 Analog < 1MHz to band edge

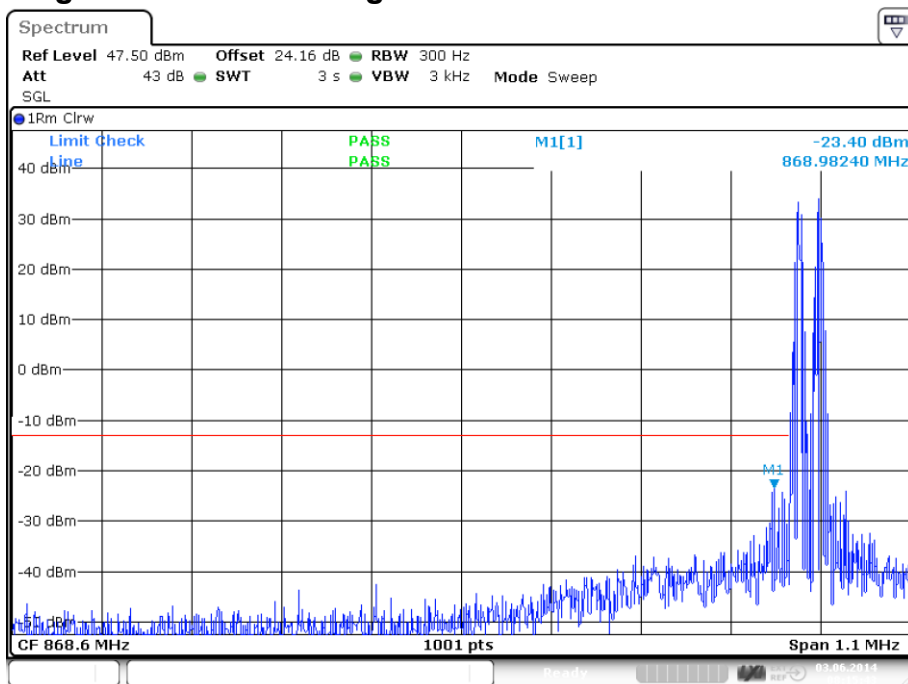

Date: 3.JUN.2014 08:15:43

plot 7.3.1.1-#1 Spurious Emissions at Antenna Terminals: §22.917, §2.1051; RSS-131, RSS-GEN; Test results; Downlink; Analog < 1MHz to band edge Lower Band Edge

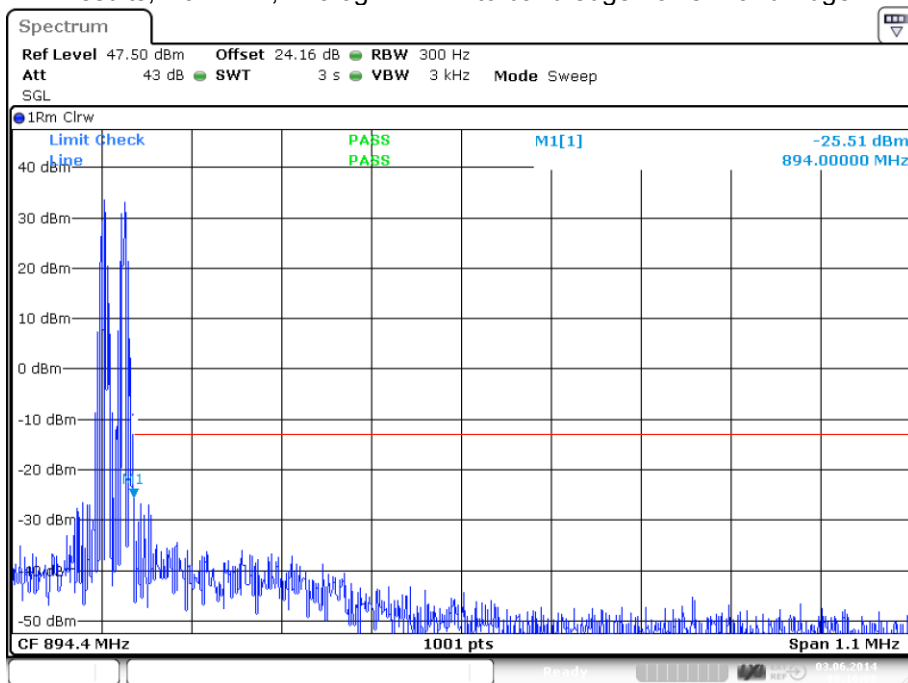

Date: 3.JUN.2014 08:16:00

plot 7.3.1.1-#2 Spurious Emissions at Antenna Terminals: §22.917, §2.1051; RSS-131, RSS-GEN; Test results; Downlink; Analog < 1MHz to band edge Upper Band Edge



7.3.1.2 GSM < 1MHz to band edge

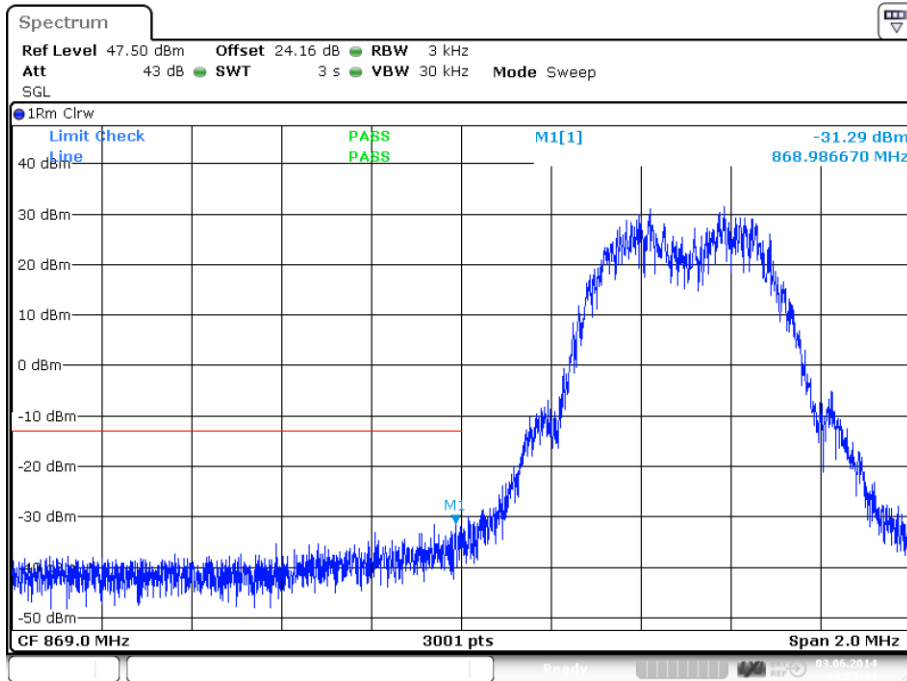

plot 7.3.1.2-#1 Spurious Emissions at Antenna Terminals: §22.917, §2.1051; RSS-131, RSS-GEN; Test results; Downlink; GSM < 1MHz to band edge Lower Band Edge

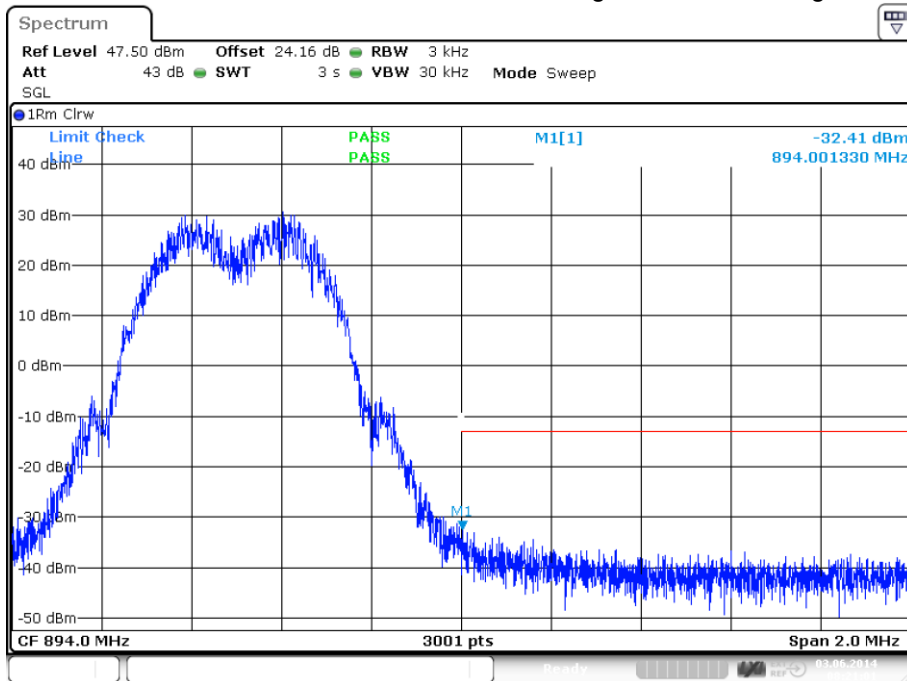

plot 7.3.1.2-#2 Spurious Emissions at Antenna Terminals: §22.917, §2.1051; RSS-131, RSS-GEN; Test results; Downlink; GSM < 1MHz to band edge Upper Band Edge



7.3.1.3 EDGE < 1MHz to band edge

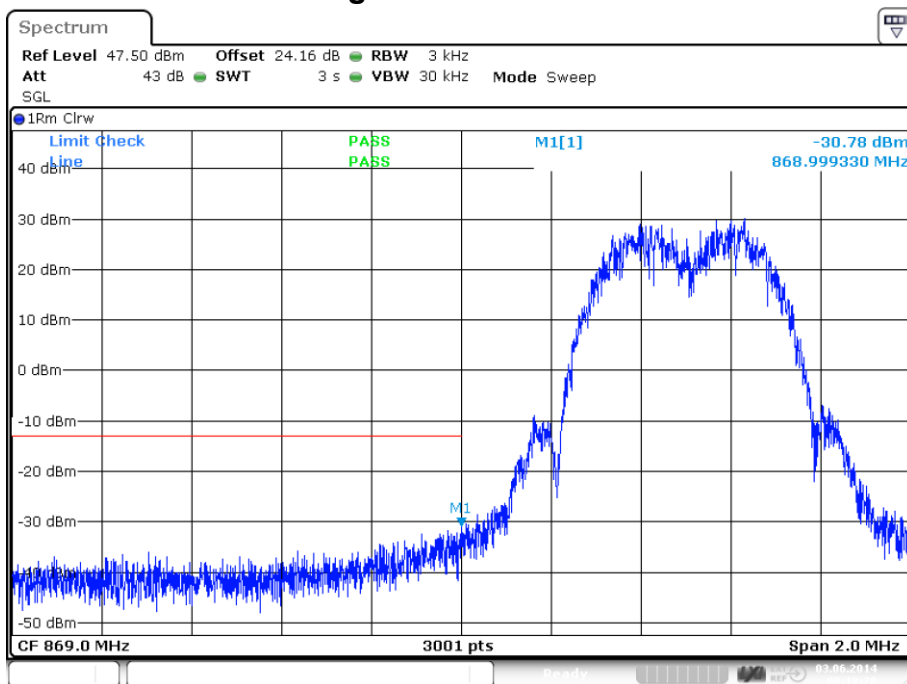

Date: 3.JUN.2014 08:18:28

plot 7.3.1.3-#1 Spurious Emissions at Antenna Terminals: §22.917, §2.1051; RSS-131, RSS-GEN; Test results; Downlink; EDGE < 1MHz to band edge Lower Band Edge

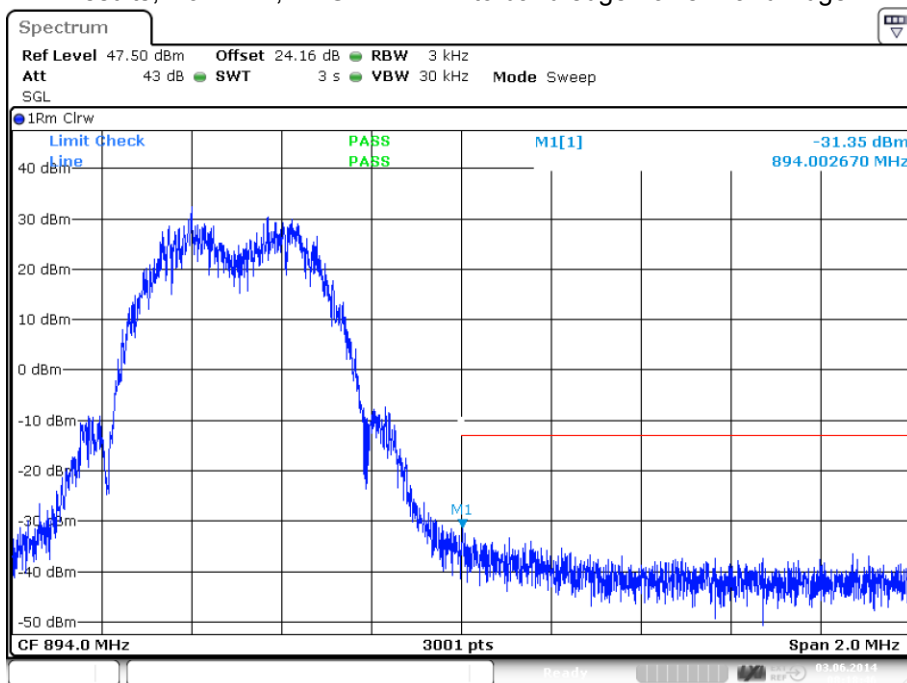

Date: 3.JUN.2014 08:18:46

plot 7.3.1.3-#2 Spurious Emissions at Antenna Terminals: §22.917, §2.1051; RSS-131, RSS-GEN; Test results; Downlink; EDGE < 1MHz to band edge Upper Band Edge





7.3.1.4 CDMA < 1MHz to band edge

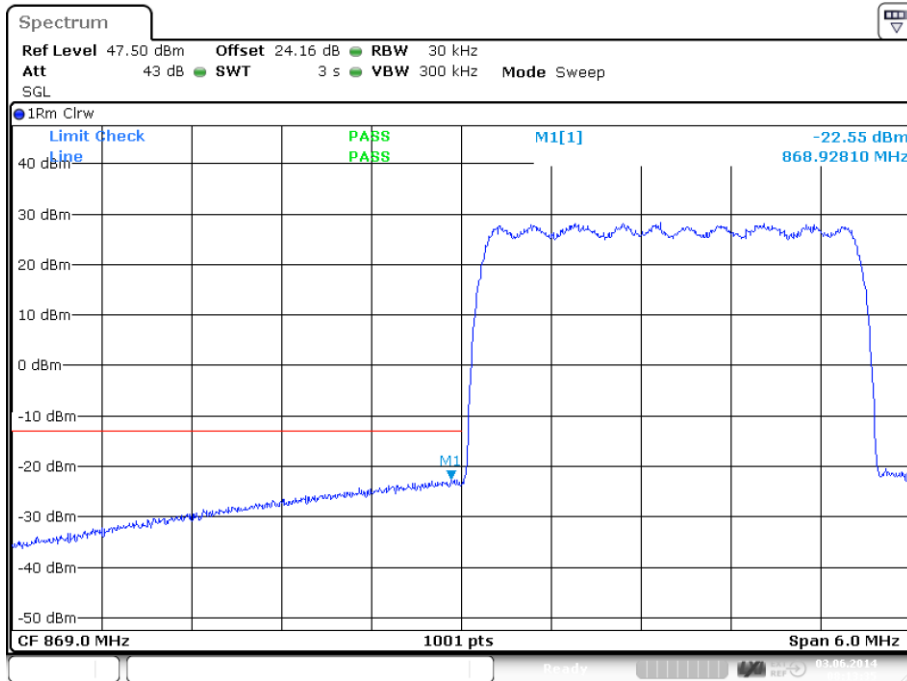

plot 7.3.1.4-#1 Spurious Emissions at Antenna Terminals: §22.917, §2.1051; RSS-131, RSS-GEN; Test results; Downlink; CDMA < 1MHz to band edge Lower Band Edge

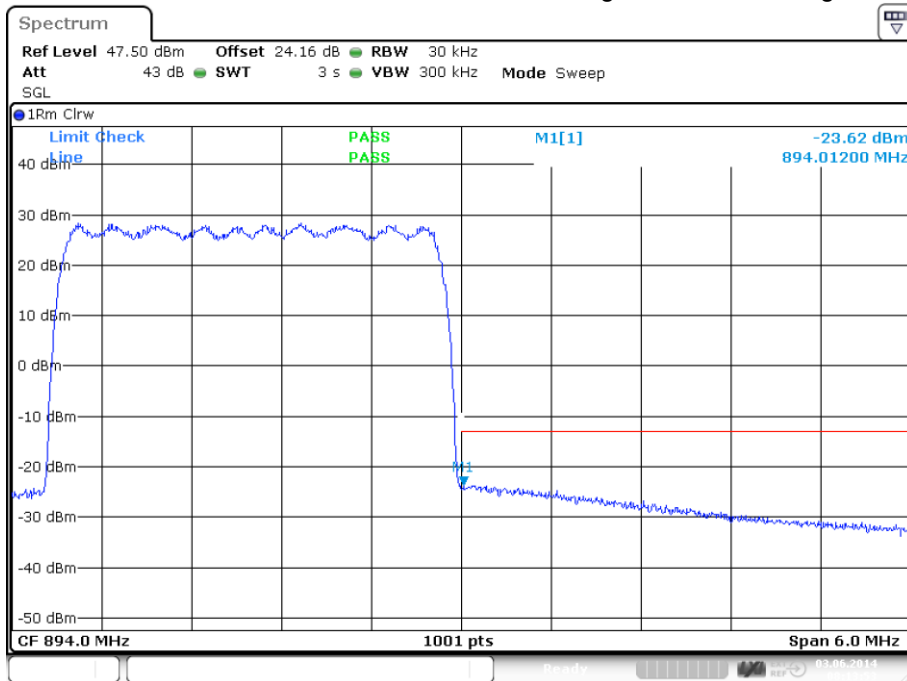

plot 7.3.1.4-#2 Spurious Emissions at Antenna Terminals: §22.917, §2.1051; RSS-131, RSS-GEN; Test results; Downlink; CDMA < 1MHz to band edge Upper Band Edge



7.3.1.5 WCDMA < 1MHz to band edge

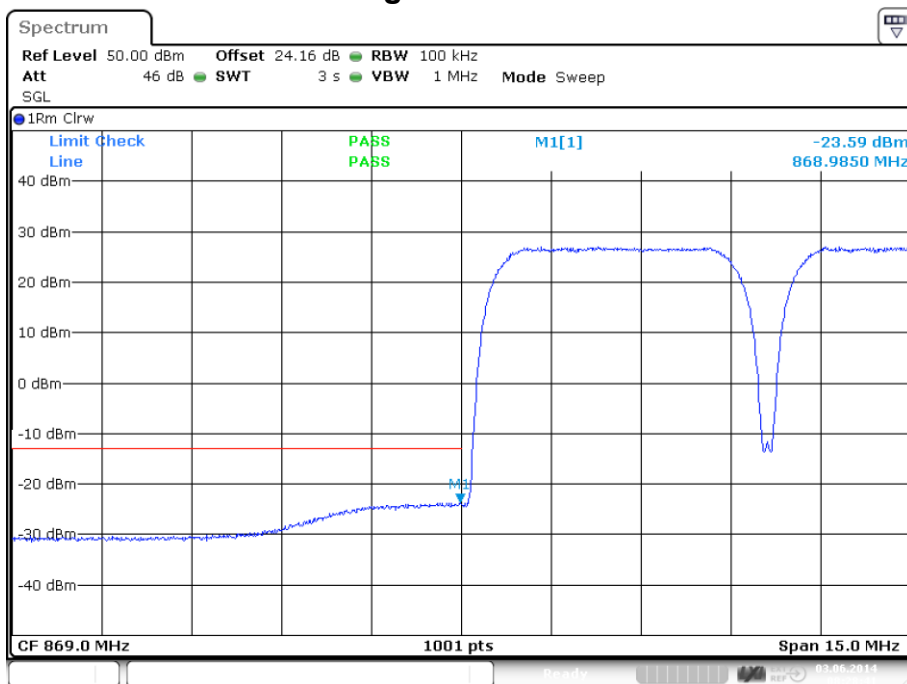

Date: 3.JUN.2014 08:28:41

plot 7.3.1.5-#1 Spurious Emissions at Antenna Terminals: §22.917, §2.1051; RSS-131, RSS-GEN; Test results; Downlink; WCDMA < 1MHz to band edge Lower Band Edge

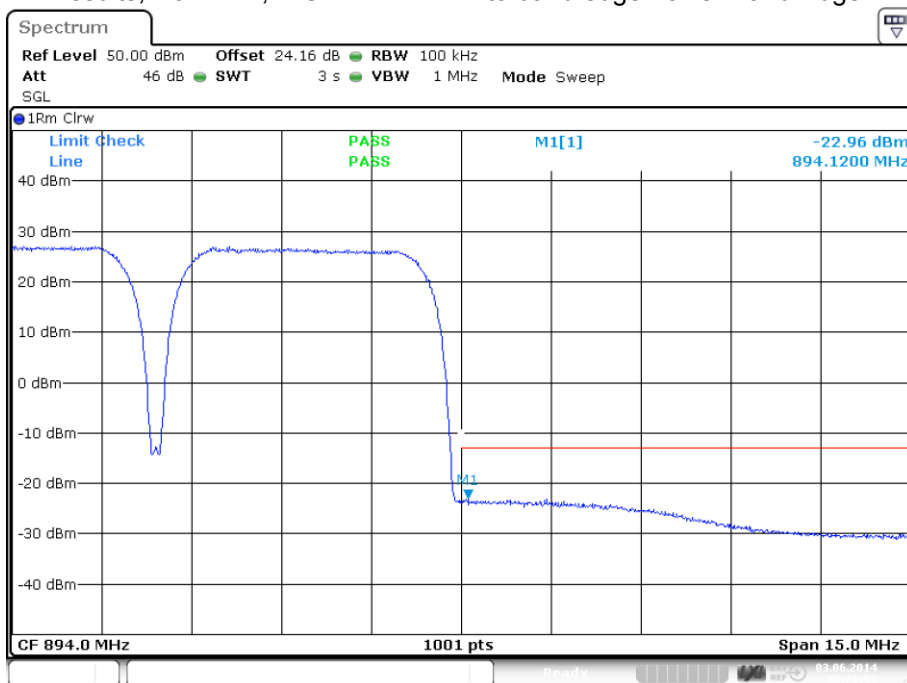

Date: 3.JUN.2014 08:28:53

plot 7.3.1.5-#2 Spurious Emissions at Antenna Terminals: §22.917, §2.1051; RSS-131, RSS-GEN; Test results; Downlink; WCDMA < 1MHz to band edge Upper Band Edge



7.3.1.6 LTE < 1MHz to band edge

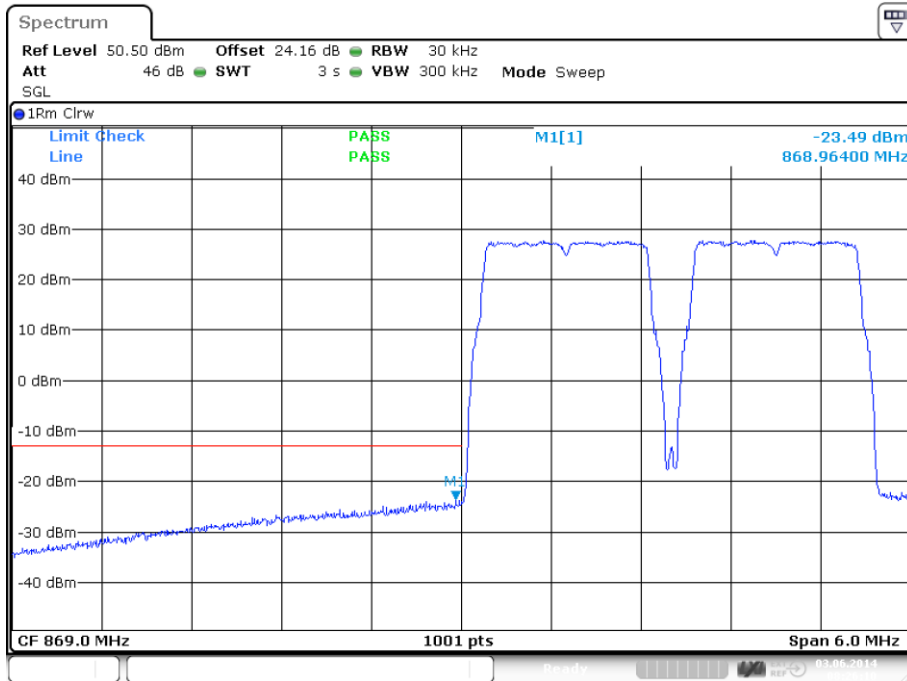

Date: 3.JUN.2014 08:26:11

plot 7.3.1.6-#1 Spurious Emissions at Antenna Terminals: §22.917, §2.1051; RSS-131, RSS-GEN; Test results; Downlink; LTE < 1MHz to band edge Lower Band Edge

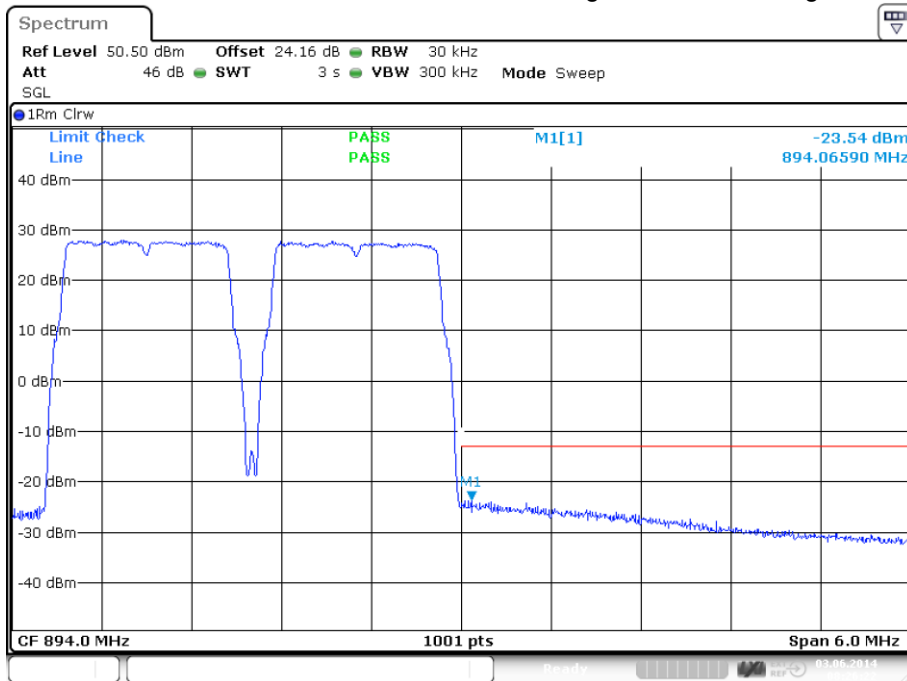

Date: 3.JUN.2014 08:26:22

plot 7.3.1.6-#2 Spurious Emissions at Antenna Terminals: §22.917, §2.1051; RSS-131, RSS-GEN; Test results; Downlink; LTE < 1MHz to band edge Upper Band Edge



### 7.3.1.7 Analog > 1MHz to band edge

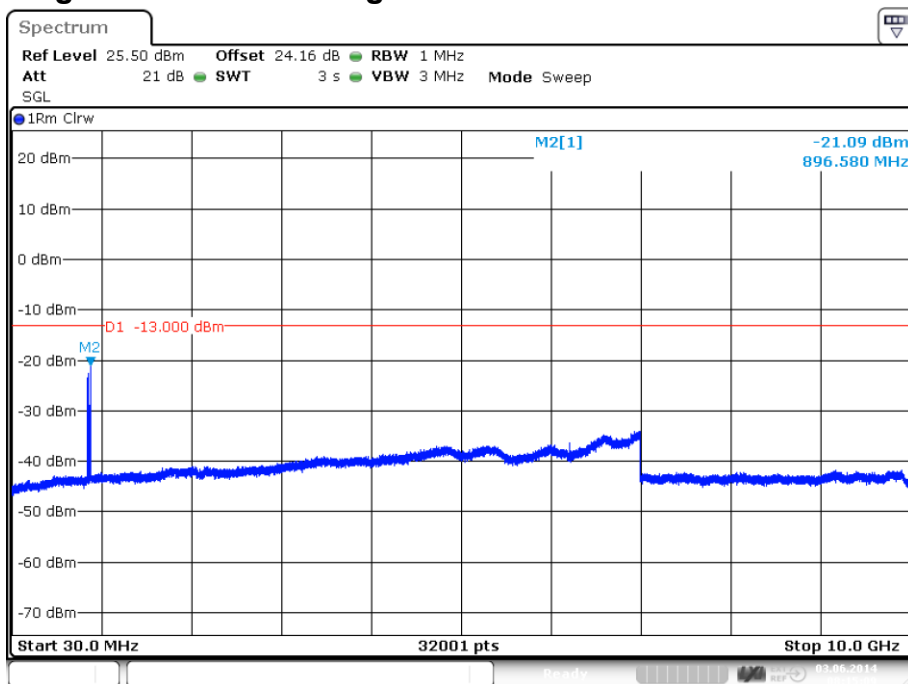

Date: 3.JUN.2014 08:15:10

plot 7.3.1.7-#1 Spurious Emissions at Antenna Terminals: §22.917, §2.1051; RSS-131, RSS-GEN; Test results; Downlink; Analog > 1MHz to band edge; carrier (881,5MHz) notched

### 7.3.1.8 GSM > 1MHz to band edge

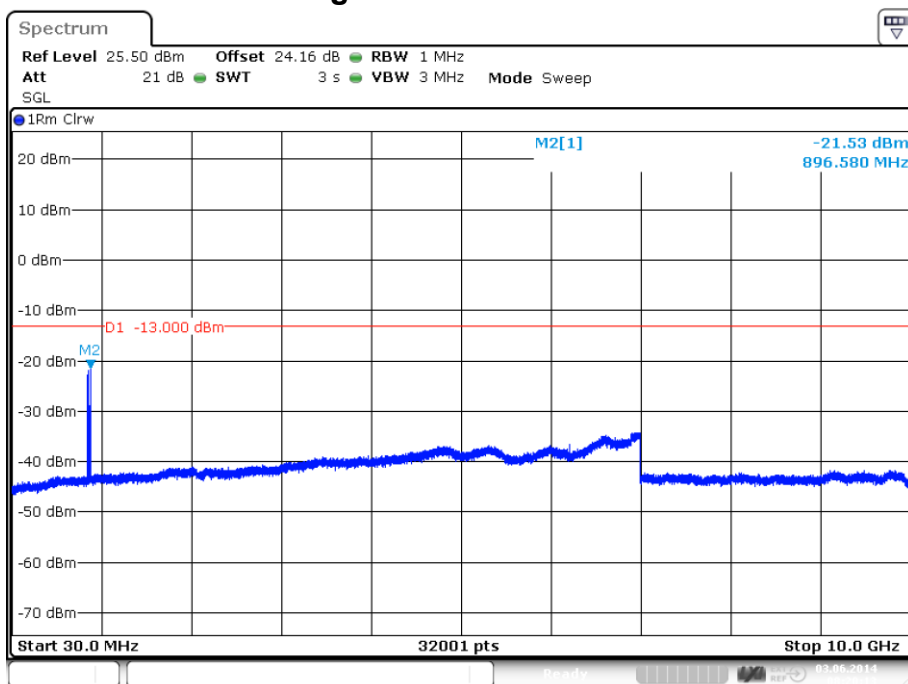

Date: 3.JUN.2014 08:20:13

plot 7.3.1.8-#1 Spurious Emissions at Antenna Terminals: §22.917, §2.1051; RSS-131, RSS-GEN; Test results; Downlink; GSM > 1MHz to band edge; carrier (881,5MHz) notched



7.3.1.9 EDGE > 1MHz to band edge

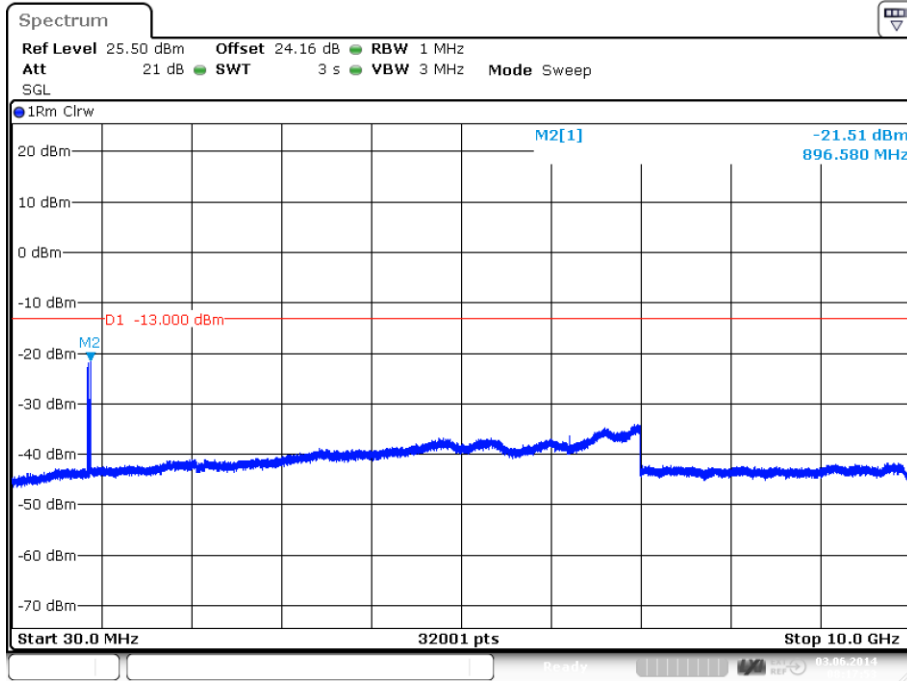

Date: 3.JUN.2014 08:17:54

plot 7.3.1.9-#1 Spurious Emissions at Antenna Terminals: §22.917, §2.1051; RSS-131, RSS-GEN; Test results; Downlink; EDGE > 1MHz to band edge; carrier (881,5MHz) notched

7.3.1.10 CDMA > 1MHz to band edge

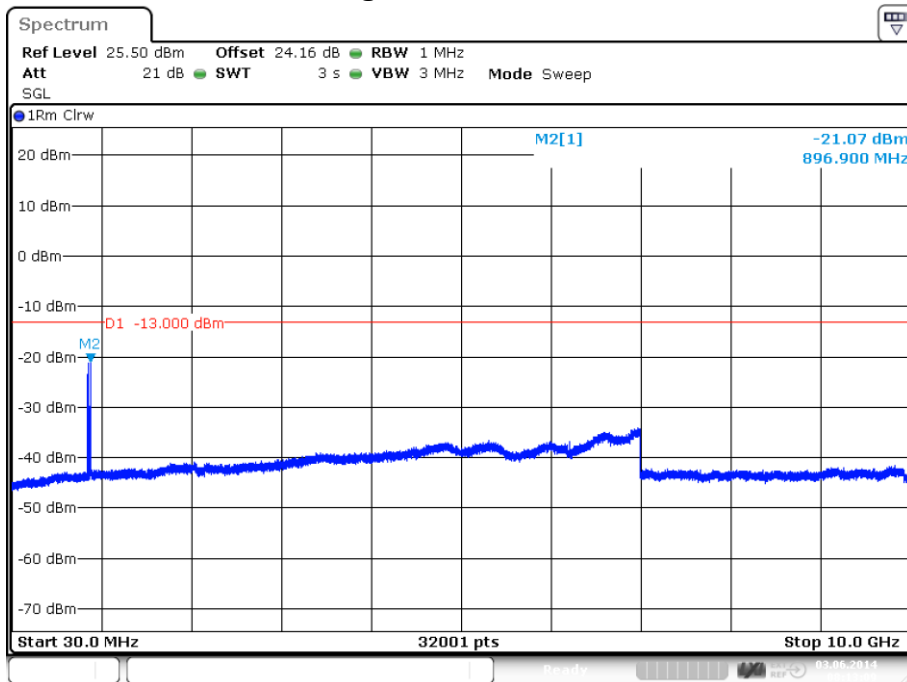

Date: 3.JUN.2014 08:13:09

plot 7.3.1.10-#1 Spurious Emissions at Antenna Terminals: §22.917, §2.1051; RSS-131, RSS-GEN; Test results; Downlink; CDMA > 1MHz to band edge; carrier (881,5MHz) notched



7.3.1.11 WCDMA > 1MHz to band edge

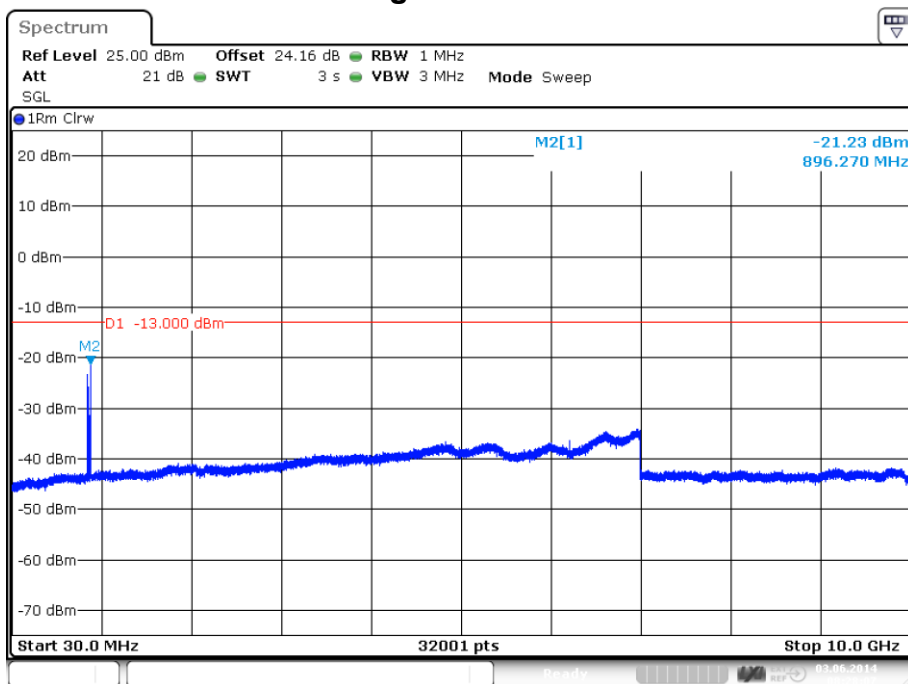

plot 7.3.1.11-#1 Spurious Emissions at Antenna Terminals: §22.917, §2.1051; RSS-131, RSS-GEN; Test results; Downlink; WCDMA > 1MHz to band edge; carrier (881,5MHz) notched

7.3.1.12 LTE > 1MHz to band edge

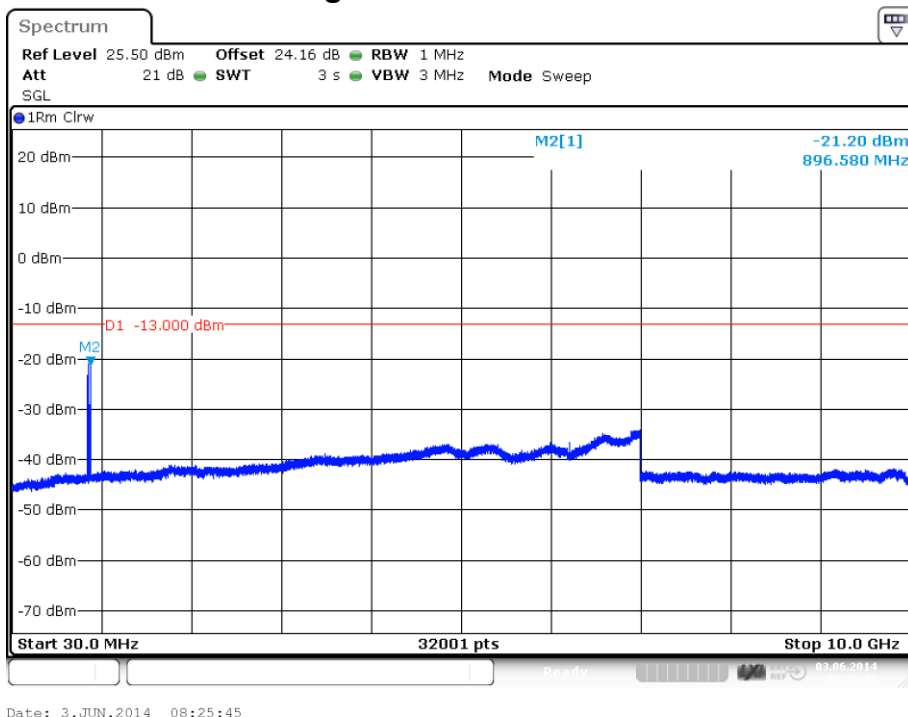

plot 7.3.1.12-#1 Spurious Emissions at Antenna Terminals: §22.917, §2.1051; RSS-131, RSS-GEN; Test results; Downlink; LTE > 1MHz to band edge; carrier (881,5MHz) notched



### 7.3.2 Uplink

n.a.

Note: The EUT does not transmit over the air in the uplink direction.

### 7.4 Summary test result

Test result	complies, according the plots above
Tested by:	M. Leinfelder
Date:	03.06.2014

## 8 Out of Band Rejection

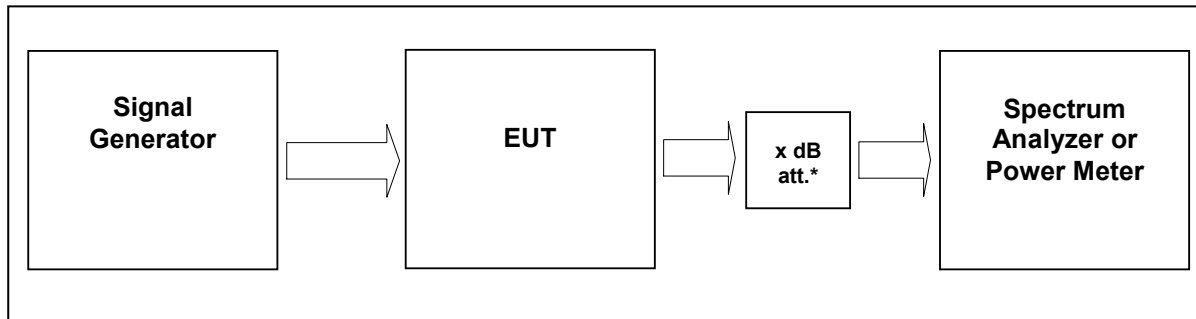

External Attenuator DL      x dB = 20 dB  
 figure 8-#1 Test setup: Out of Band Rejection

Measurement uncertainty	± 0,38 dB
Test equipment used	9054; 9233; 7336; 7408; 7449; 7444; 7374;

### 8.1 Limit

KDB 935210 D02 v02

Test for rejection of out of band signals. Filter frequency response plots are acceptable.

### 8.2 Test method

935210 D03 v02

7.1 Authorized frequency band verification test

### 8.3 Test results

Detector Peak max hold





### 8.3.1 Downlink

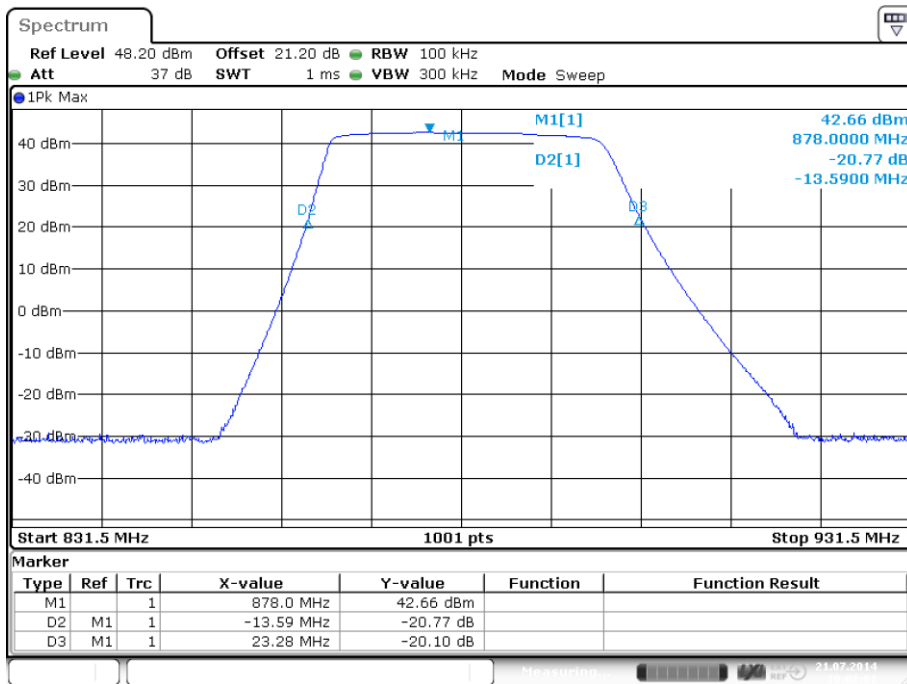

plot 8.3.1-#1 Out of Band Rejection; Test results; Downlink;

### 8.3.2 Uplink

n.a.

Note: The EUT does not transmit over the air in the uplink direction.

### 8.4 Summary test result

Test result	complies, according the plots above
Tested by:	M. Leinfelder
Date:	21.07.2014

## 9 Field Strength of Spurious Emissions: §22.917, §2.1053



picture 8.1: label



picture 8.2: Test setup: Field Strength Emission <1 GHz @3m in the FAC



**picture 8.3:** Test setup: Field Strength Emission >1 GHz @3m in the FAC



This clause specifies requirements for the measurement of radiated emission.

Frequency range	Distance: EUT <-> antenna / location	Limit	Test method
30 MHz – 12.75 GHz	3 metres / FAC	FCC 47 CFR Part 22.917	TIA/EIA-603-C:2004
		IC RSS-131	

**Test equipment used:**

Designation	Type	Manufacturer	Invent.- no.	Cal.-date	due Cal.- date	used
EMI test receiver	ESI40	Rohde & Schwarz	E1687	28.11.2013	28.11.2014	X
Antenna	CBL 6111	Chase	K1149	23.01.2014	23.01.2015	X
RF Cable		Frankonia	K1737/8/9 Set	27.03.2013	27.03.2015	X
Antenna	HL 025	R&S	K1114	31.07.2013	31.07.2014	X
Preamplifier	AFS4-00102000	Miteq	K838	03.04.2014	03.04.2015	X
RF Cable	Sucoflex 100	Suhner	K1742	02.07.2014	02.07.2015	X

The REMI version 2.135 has been used for max search.

**Test set-up:**

Test location: FAC  
 Both, the Fully Anechoic Chamber (FAC) and the Semi Anechoic Chamber (SAC) fulfil the requirements of ANSI C63.4 and CISPR 16-1-4 with regards to NSA and SVSWR.

Test Voltage: 115V / 60 Hz  
 Type of EUT: Wall mounted

**Measurement uncertainty:**

Measurement uncertainty expanded (95% or K=2)	± 4,7 dB for ANSI C63.4 measurement ± 0,5 dB for TIA-603 measurement
--	---



## 9.1 Limit §22.917

The rules in this section govern the spectral characteristics of emissions in the Broadband Personal Communications Service.

(a) *Out of band emissions.* The power of any emission outside of the authorized operating frequency ranges must be attenuated below the transmitting power (P) by a factor of at least  $43 + 10 \log(P)$  dB.

(b) *Measurement procedure.* Compliance with these rules is based on the use of measurement instrumentation employing a resolution bandwidth of 1 MHz or greater. However, in the 1 MHz bands immediately outside and adjacent to the frequency block a resolution bandwidth of at least one percent of the emission bandwidth of the fundamental emission of the transmitter may be employed. A narrower resolution bandwidth is permitted in all cases to improve measurement accuracy provided the measured power is integrated over the full required measurement bandwidth (i.e. 1 MHz or 1 percent of emission bandwidth, as specified). The emission bandwidth is defined as the width of the signal between two points, one below the carrier center frequency and one above the carrier center frequency, outside of which all emissions are attenuated at least 26 dB below the transmitter power.

The emission measurements have been made with transmission at **Bottom/Middle/Top** frequency **(869MHz/881.5MHz/894MHz)**

The limit is -13dBm (e.i.r.p).



## 9.2 Test method ANSI/TIA/EA-603-C

### Measurement procedure. TIA-603-C

The antenna substitution method is used to determine the equivalent radiated power at spurious frequencies. The spurious emissions are measured at a distance of 3 meters. The EUT is then replaced with a reference substitution antenna with a known gain referenced to a dipole. This antenna is fed with a signal at the spurious frequency. The level of the signal is adjusted to repeat the previously measured level. The resulting eirp is the signal level fed to the reference antenna corrected for gain referenced to an isotropic dipole (see Figure 7.2).

From KDB (AMPLIFIER, BOOSTER, AND REPEATER REMINDER SHEET):

Radiated spurs (enclosure) – Use of CW signal (low, mid. and high freq.) is acceptable rather than all modulations.

The maximum RFI field strength was determined during the measurement by rotating the turntable ( $\pm 180$  degrees) and varying the height of the receive antenna ( $h = 1 \dots 4$  m) as like defined in ANSI C63.4. A measurement receiver has been used with a RBW 120 kHz up to 1 GHz and 1 MHz above 1 GHz. Steps with during pre measurement was half the RBW.

Both, the Fully Anechoic Chamber (FAC) and the Semi Anechoic Chamber (SAC) fulfill the requirements of ANSI C63.4 and CISPR 16-1-4 with regards to NSA and SVSWR.

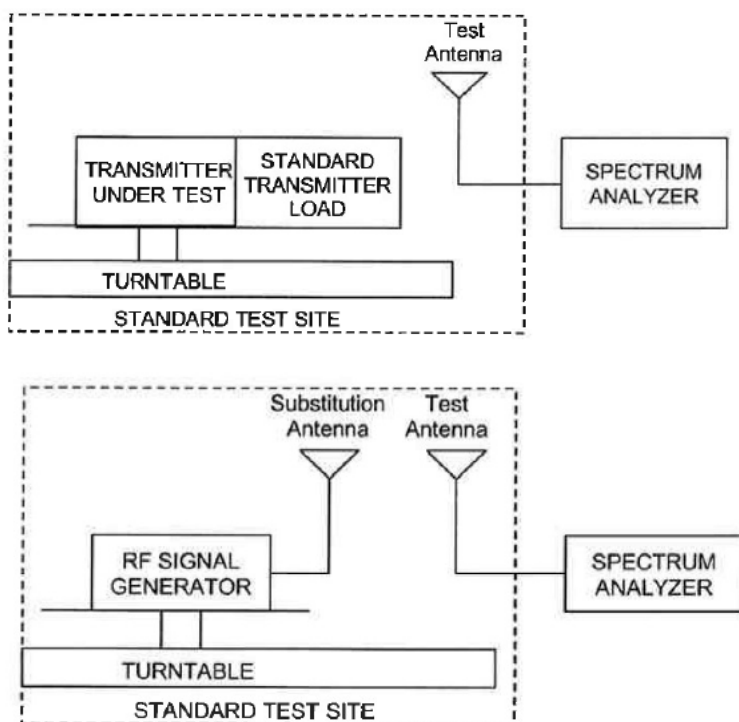

picture 8.3: Substitution method

## 9.3 Climatic values in the lab

Temperature: 20°  
 Relative Humidity: 45%  
 Air-pressure: 1009hPa

### 9.4 Test results

#### 9.4.1 30 MHz to 1 GHz Downlink (Bottom – Middle – Top) Subpart H

B/M/T: 869MHz/881.5MHz/894MHz

Vertikal / Horizontal

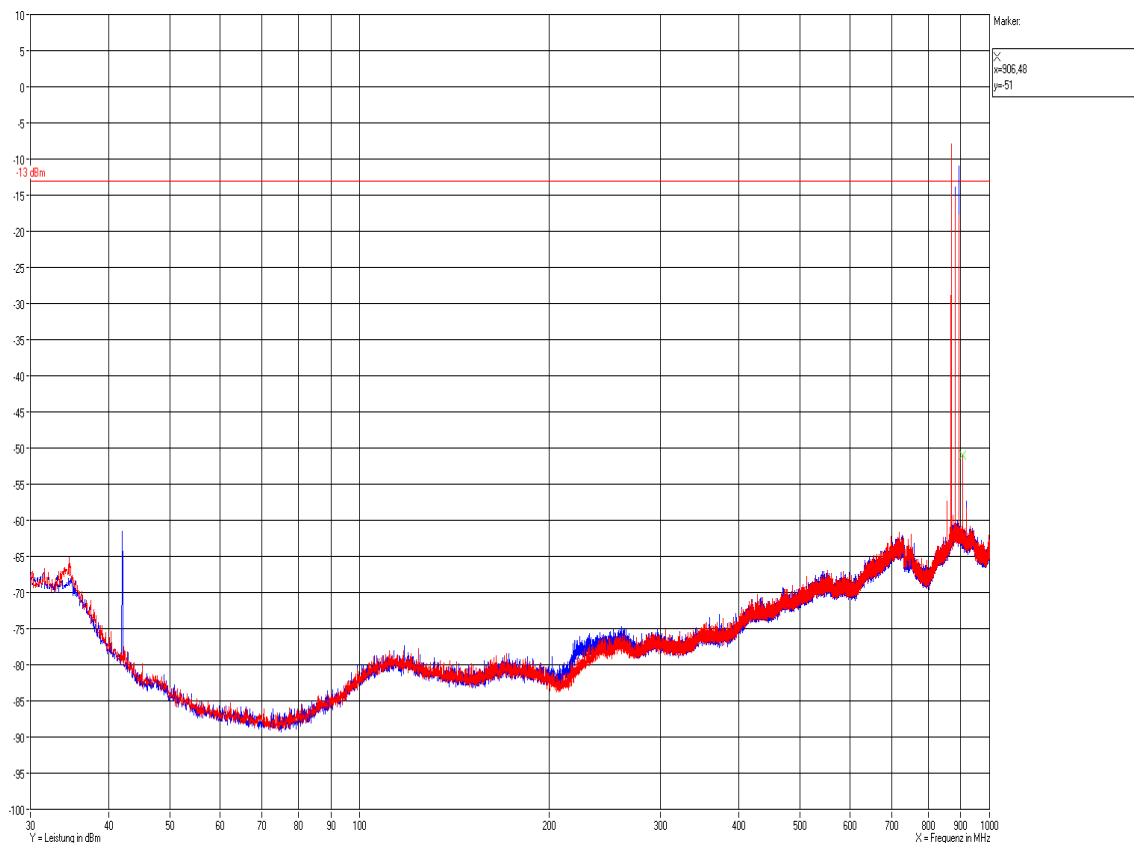

The RF output power is terminated.



### 9.4.2 30 MHz to 1 GHz Downlink (Middle of all paths)

F1: 751.5 MHz; F2: 737 MHz; F3: 881.5 MHz

Vertikal / Horizontal

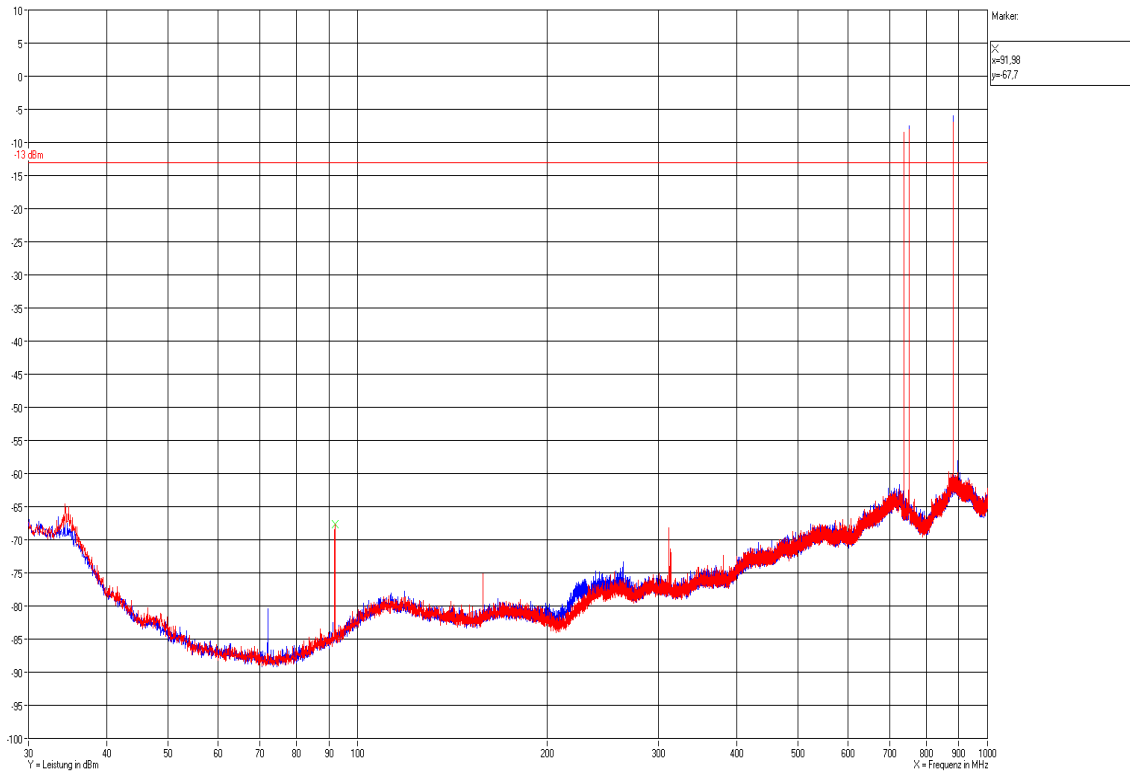

The RF output power is terminated.





### 9.4.3 1 GHz to 12.75 GHz Downlink (Bottom – Middle – Top) Subpart H

B/M/T: 869MHz/881.5MHz/894MHz

Vertikal / Horizontal

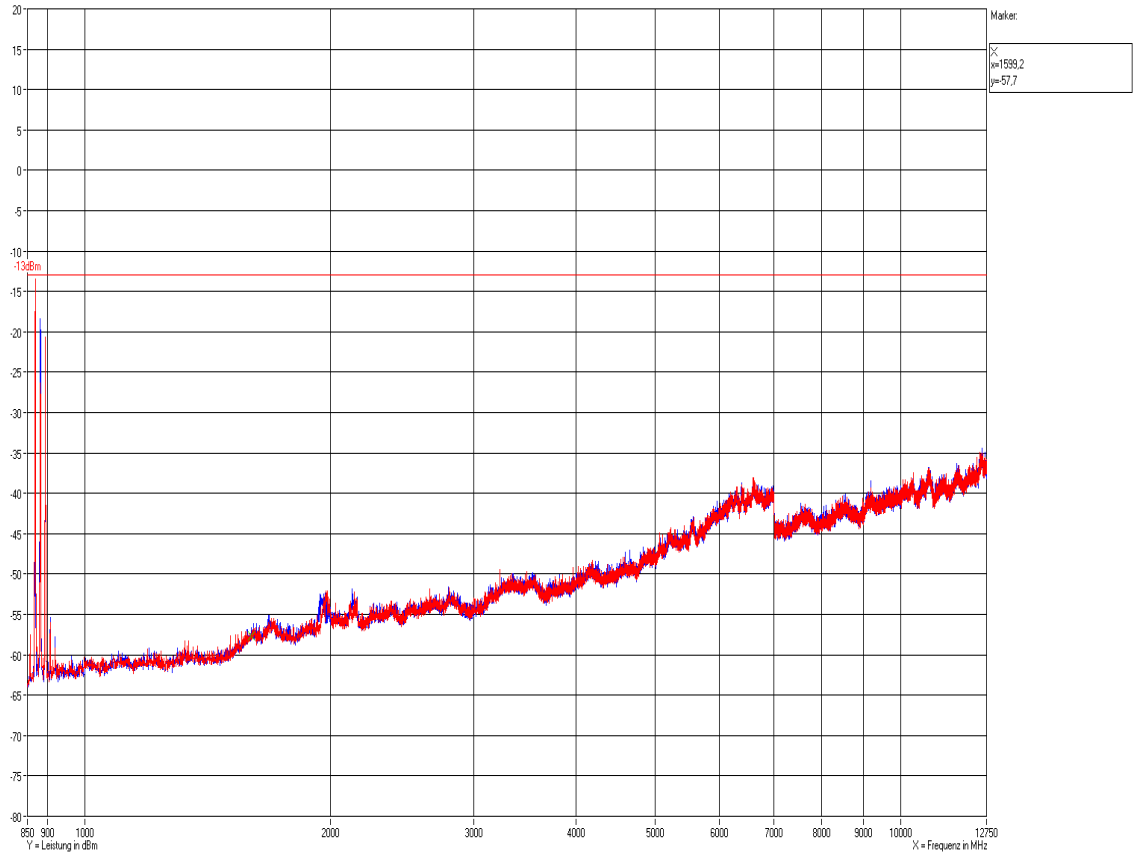

The RF output power is terminated.



### 9.4.4 1 GHz to 12.75 GHz Downlink (Middle of all paths)

F1: 751.5 MHz; F2: 737 MHz; F3: 881.5 MHz

Vertikal / Horizontal

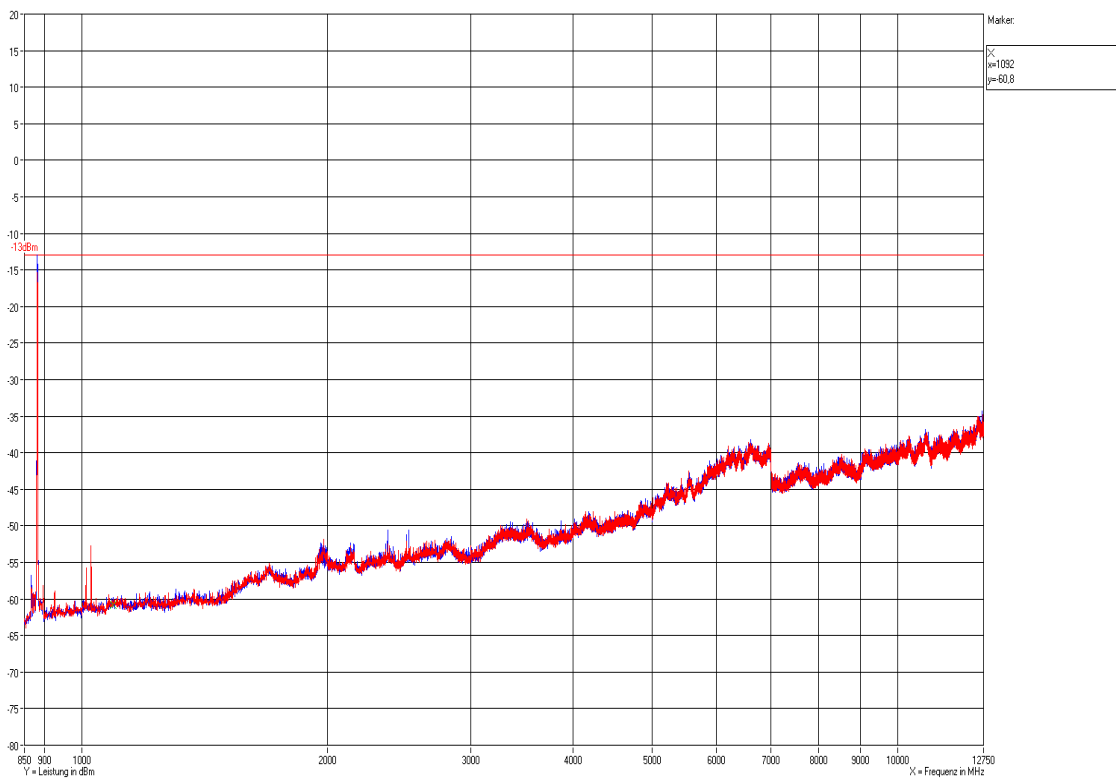

The RF output power is terminated.

FEK / 17.07.2014

**The radiated spurious emission measurements have been passed!**



## 10 History

Revision	Modification	Date	Name
V01.00	Initial	17.07.2014	Tom Zahlmann

**\*\*\*\*\* End of test report \*\*\*\*\***