

Test Site:
FCC Test Site No.:
IC OATS No.:

96997
IC3475A-1



ECL-EMC Test Report No.: 12-089

Equipment under test: ION-M7HP/7HP/85HP/19P 850MHz Path
FCC ID: XS5-M7785HP19P
IC ID: 2237E-M7785HP19P
Type of test: FCC 47 CFR Part 22 Subpart H:2009
Cellular Radiotelephone Service
IC RSS-131:2003
Zone Enhancers for the Land Mobile Service

Measurement Procedures: 47 CFR Parts 2: 2011 (*Frequency Allocations and Radio Treaty Matters; General Rules and Regulations*),
Part 22: 2011 (*Cellular Radiotelephone Service*),
ANSI/TIA-603-C (2004), *Land Mobile FM or PM Communications Equipment Measurement and Performance Standards*
IC RSS-GEN: 2010 General Requirements and Information for the Certification of Radiocommunication Equipment

Test result: **Passed**

Date of issue:	16.05.12		Signature:
Issue-No.:	01	Author:	
Date of delivery:	08.05.12	Checked:	
Test dates:	09.05. – 10.05.12		
Pages:	59		

Test Report No.: 12-089

FCC ID: XS5-M7785HP19P

IC ID: 2237E-M7785HP19P



Manufacturer: ANDREW Wireless Systems GmbH
Industriering 10

D-86675 Buchdorf

Tel.: +49 (0)9099 69 0

Fax: +49 (0)9099 69 140

Test Location: TEMPTON Service Plus GmbH
European Compliance Laboratory (ECL)

Thurn-und-Taxis-Straße 18

D-90411 Nürnberg

Tel.: +49 0911 59835 0

Fax: +49 0911 59835 90

General:

The purpose of this report is to show compliance to the FCC regulations for licensed devices operating under section 22 of the Code of Federal Regulations title 47.

This report informs about the results of the RF tests, it only refers to the equipment under test. No part of this report may be reproduced in any form, without written permission.



Table of contents

1	TEST RESULTS SUMMARY	6
2	EQUIPMENT UNDER TEST (E.U.T.)	7
2.1	DESCRIPTION	7
2.1.1	DOWNLINK	7
2.1.2	UPLINK	7
2.1.3	DESCRIPTION OF EUT	8
2.1.4	BLOCK DIAGRAM OF MEASUREMENT REFERENCE POINTS	8
2.1.5	DOWNLINK SYSTEM GAIN AND OUTPUT POWER	9
3	TEST SITE (ANDREW BUCHDORF)	9
3.1	TEST ENVIRONMENT	9
3.2	TEST EQUIPMENT	10
3.3	INPUT AND OUTPUT LOSSES	10
3.4	MEASUREMENT UNCERTAINTY	10
4	TEST SITE (TEMPTON SERVICE PLUS GMBH)	11
5	RF POWER OUT: §22.913, §2.1046; IC RSS-131	12
5.1	LIMIT	12
5.2	TEST METHOD	12
5.3	TEST RESULTS	13
5.3.1	DOWNLINK	14
5.3.1.1	Analog	15
5.3.1.2	GSM	15
5.3.1.3	EDGE	16
5.3.1.4	CDMA	16
5.3.1.5	WCDMA	17
5.3.1.6	LTE	17
5.3.2	UPLINK	18
5.4	SUMMARY TEST RESULT	18
6	OCCUPIED BANDWIDTH: §2.1049; RSS-GEN	19
6.1	LIMIT	19
6.2	TEST METHOD	19
6.3	TEST RESULTS	19
6.3.1	DOWNLINK	20
6.3.1.1	Analog	21
6.3.1.2	GSM	22
6.3.1.3	EDGE	23
6.3.1.4	CDMA	24
6.3.1.5	WCDMA	25
6.3.1.6	LTE	26
6.3.2	UPLINK	27
6.4	SUMMARY TEST RESULT	27



7	SPURIOUS EMISSIONS AT ANTENNA TERMINALS: §22.917, §2.1051; RSS-131, RSS-GEN.....	28
7.1	LIMIT.....	28
7.2	TEST METHOD	28
7.3	TEST RESULTS	29
7.3.1	DOWNLINK	29
7.3.1.1	Analog < 1MHz to band edge.....	31
7.3.1.2	GSM < 1MHz to band edge.....	32
7.3.1.3	EDGE < 1MHz to band edge.....	33
7.3.1.4	CDMA < 1MHz to band edge.....	34
7.3.1.5	WCDMA < 1MHz to band edge.....	35
7.3.1.6	LTE < 1MHz to band edge.....	36
7.3.1.7	Analog > 1MHz to band edge.....	37
7.3.1.8	GSM > 1MHz to band edge.....	37
7.3.1.9	EDGE > 1MHz to band edge.....	38
7.3.1.10	CDMA > 1MHz to band edge.....	38
7.3.1.11	WCDMA > 1MHz to band edge.....	39
7.3.1.12	LTE > 1MHz to band edge.....	39
7.3.2	UPLINK	40
7.4	SUMMARY TEST RESULT.....	40
8	AMPLIFIER GAIN AND BANDWIDTH: IC RSS-131.....	41
8.1	LIMIT.....	41
8.2	TEST METHOD	41
8.3	TEST RESULTS	41
8.3.1	DOWNLINK	41
8.3.2	UPLINK	42
8.4	SUMMARY TEST RESULT.....	42
9	OUTPUT POWER: IC RSS-131.....	43
9.1	LIMIT.....	43
9.2	TEST METHOD	43
9.3	TEST RESULTS	44
9.3.1	DOWNLINK	44
9.3.2	UPLINK	44
9.4	SUMMARY TEST RESULT.....	44
10	NON-LINEARITY: IC RSS-131.....	45
10.1	LIMIT	45
10.2	TEST METHOD.....	45
10.3	TEST RESULTS.....	46
10.3.1	DOWNLINK	46
10.3.2	UPLINK	46
10.4	SUMMARY TEST RESULT	46
11	SPURIOUS EMISSIONS: RSS-131	47
11.1	LIMIT	47
11.2	TEST METHOD.....	47



11.3	TEST RESULTS.....	47
11.3.1	DOWNLINK.....	47
11.3.2	UPLINK.....	49
11.4	SUMMARY TEST RESULT.....	49
12	FIELD STRENGTH OF SPURIOUS EMISSIONS: §22.917, §2.1053.....	50
12.1	LIMIT §22.917.....	53
12.2	TEST METHOD ANSI/TIA/EA-603-C.....	54
12.3	CLIMATIC VALUES IN THE LAB.....	54
12.4	TEST RESULTS.....	55
12.4.1	30 MHZ TO 1 GHZ DOWNLINK (BOTTOM – MIDDLE – TOP).....	55
12.4.2	1 GHZ TO 22 GHZ DOWNLINK (MIDDLE OF ALL PATHS).....	56
12.4.3	1 GHZ TO 22 GHZ DOWNLINK (BOTTOM – MIDDLE – TOP).....	57
12.4.4	1 GHZ TO 22 GHZ DOWNLINK (MIDDLE OF ALL PATHS).....	58
12.5	SUMMARY TEST RESULT.....	58
13	HISTORY.....	58



1 Test Results Summary

Name of Test	FCC Para. No.	FCC Method	FCC Spec.	Result
RF Power Output	22.913	2.1046	500 Watts	Complies
Occupied Bandwidth		2.1049	Input/Output	Complies
Spurious Emissions at Antenna Terminals	22.917	2.1051	-13dBm	Complies
Field Strength of Spurious Emissions	22.917	2.1053	-13dBm E.I.R.P	Complies
Frequency Stability	n.a.	2.1055	Must stay in band	NA

Name of Test	IC Para. No.	IC Method	Result
RF Power Output	RSS-131	RSS-GEN 4.8	Complies
Occupied Bandwidth	RSS-131	RSS-GEN 4.6.1	Complies
Spurious Emissions at Antenna Terminals	RSS-131	RSS-GEN 4.9	Complies
Field Strength of Spurious Emissions	RSS-131 6.4	RSS-GEN 4.9	Complies
Frequency Stability	RSS-131	RSS-GEN 4.7	NA

Frequency stability is given by: The system gets an electrical analog signal from the BSS which is converted into an analog optical signal, transmitted by the optical links and then reconverted in the Remote Unit into an analog electrical signal. During this process happens no frequency change/modification, so input and output have same frequency what can be seen under clause "Occupied Bandwidth".



2 Equipment under test (E.U.T.)

2.1 Description

Kind of equipment	ION-M7HP/7HP/85HP/19P
Andrew Ident. Number	Id. No. 7643936-0001
Serial no.(SN)	12
Revision	00
Software version and ID	n. a.
Type of modulation and Designator	Analog (F3E (Voice)) <input checked="" type="checkbox"/> GSM (GXW) <input checked="" type="checkbox"/> GSM EDGE (G7W) <input checked="" type="checkbox"/> CDMA (F9W) <input checked="" type="checkbox"/> W-CDMA (F9W) <input checked="" type="checkbox"/> LTE QAM (D7D) <input checked="" type="checkbox"/>
Frequency Translation	F1-F1 <input checked="" type="checkbox"/> F1-F2 <input type="checkbox"/> N/A <input type="checkbox"/>
Band Selection	Software <input type="checkbox"/> Duplexer <input checked="" type="checkbox"/> Full band <input type="checkbox"/>

2.1.1 Downlink

Pass band	Path 869 MHz – 894 MHz
Nominal 20dB bandwidth	36.2 MHz
Max. composite output power based on one carrier per path (rated)	45.5 dBm = 35.5 W
System Gain*	12.5 dB @ Pout BTS of 33 dBm

*see 2.1.5

2.1.2 Uplink

Pass band	Path 824 MHz – 849 MHz
Maximum rated output power	n. a.
System Gain*	n.a.

*see 2.1.5

Note: The EUT does not transmit over the air in the uplink direction.



2.1.3 Description of EUT

ION-M7HP/7HP/85HP/19P is a multi-band, multi-operator remote unit configuration used in conjunction with a master unit in the ION optical distribution system.

This system transports up to four frequency bands simultaneously (2 * 700 MHz, 850 MHz, 1900 MHz), providing a cost-effective solution for distributing capacity from one or more base stations.

The ION-M7HP/7HP/85HP/19P Repeater consists of two 700 MHz, one 850 MHz and one 1900 MHz path, with the intended use of simultaneous transmission. This Test Report describes only the approval of the 850 MHz path

2.1.4 Block diagram of measurement reference points

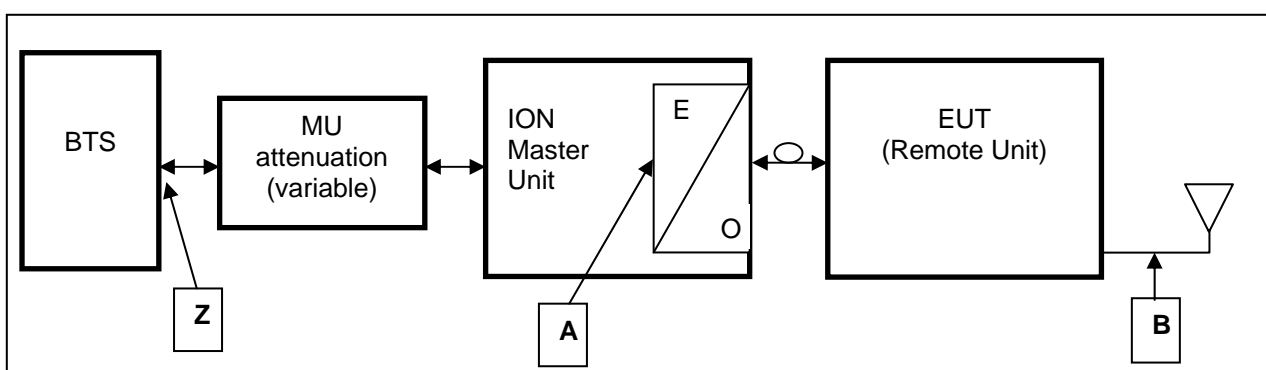

figure 2.1.4-#1 Block diagram of measurement reference points

Remote Unit is the EUT

O/E Optical / Electrical converter
 SRMU Sub Rack Master Unit

Reference point A	SRMU	UL output,	DL input
Reference point B	Remote Unit	DL output,	UL input
Reference point Z	BTS	DL output,	UL input

Downlink: Measure from reference point A to B

Since a signal generator does not supply a good output signal with +33 or +43dBm, for the downlink measurement the MU Attenuation is not used.

That means for downlink measurements the signal generator is connected to measurement point A at the master optical / electrical converter and the analyzer to the measurement point B at the RU.



2.1.5 Downlink System Gain and Output Power

System optimized for BTS power (fixed value) Z	MU Attenuation (manual leveling)	Maximum rated input power at the MU OTRX (fixed value) A	RU Gain (fixed value) A to B	Maximum rated output power at RU Antenna port (fixed value) B
+33 dBm	23.5 dB	9.5 dBm	+36 dB	+45.5 dBm @ 1 carrier
System Gain Z to A	+12.5 dB			
+43 dBm	33.5 dB	9.5 dBm	+36 dB	+45.5 dBm @ 1 carrier
System Gain Z to A	+2.5 dB			

table 2.1.5-#1 Equipment under test (E.U.T.) Description Downlink System Gain and Output Power

3 Test site (Andrew Buchdorf)

3.1 Test environment

All tests were performed under the following environmental conditions:

Condition	Minimum value	Maximum value
Barometric pressure	86 kPa	106 kPa
Temperature	15°C	30°C
Relative Humidity	20 %	75 %
Power supply range	±5% of rated voltages	



3.2 Test equipment

ANDREW Inv. No.	Test equipment	Type	Manufacturer	Serial No.	Calibration
9102	Network Analyzer	ZVB 14	R&S	100118	08/12
9054	Spectrum Analyzer	FSV13	R&S	100859	12/12
9126	Spectrum Analyzer	FSV30	R&S	101237	11/12
9101	Signal Generator	SMBV100A	R&S	256443	06/12
8990	Signal Generator	SMJ100A	R&S	101288	07/12
8671	Power Meter	E4418B	Agilent	GB39513094	06/12
8672	Power Sensor	E9300H	Agilent	US41090179	06/12
7336	Power Attenuator	768-20	Narda	04904	CIU
7119	Divider	2way	Mikom	3512	CIU
7408	RF-Cable	2,0m; N-N	Andrew	---	CIU
7409	RF-Cable	2,0m; N-N	Andrew	---	CIU
7410	RF-Cable	1,0m; N-N	Andrew	---	CIU
7411	RF-Cable	2,0m; N-N	Andrew	---	CIU
7373	RF-Cable	Multiflex141	Andrew	---	CIU
7374	RF-Cable	Multiflex141	Andrew	---	CIU
7437	RF-Cable	Multiflex141	Andrew	---	CIU
7438	RF-Cable	Multiflex141	Andrew	---	CIU
7439	RF-Cable	Multiflex141	Andrew	---	CIU
7443	RF-Cable	Multiflex141	Andrew	---	CIU
7444	RF-Cable	Multiflex141	Andrew	---	CIU
7445	RF-Cable	Multiflex141	Andrew	---	CIU
7446	RF-Cable	Multiflex141	Andrew	---	CIU
7447	RF-Cable	Multiflex141	Andrew	---	CIU
7448	RF-Cable	Multiflex141	Andrew	---	CIU
7449	RF-Cable	Multiflex141	Andrew	---	CIU
7450	RF-Cable	Multiflex141	Andrew	---	CIU
7440	RF-Cable	RG-223 0.8m	Andrew	---	CIU
7441	RF-Cable	RG-223 0.8m	Andrew	---	CIU

CIU = Calibrate in use

3.3 Input and output losses

All recorded power levels should be referenced to the input and output connectors of the repeater, unless explicitly stated otherwise.

The test equipment used in this test has to be calibrated, so that the functionality is also checked.

All cables, attenuators, splitter, isolator, circulator and combiner etc. must be measured before testing and used for compensation during testing.

3.4 Measurement uncertainty

The extended measurement uncertainty corresponds to the measurement results from the standard measurement uncertainty multiplied by the coverage factor $k=2$. The true value is located in the corresponding interval with a probability of 95 %.

Test Report No.: 12-089

FCC ID: XS5-M7785HP19P

IC ID: 2237E-M7785HP19P



4 Test site (TEMPTON Service Plus GmbH)

FCC Test site: 96997

IC OATS: 2237E

See relevant dates under section 8.



5 RF Power Out: §22.913, §2.1046; IC RSS-131

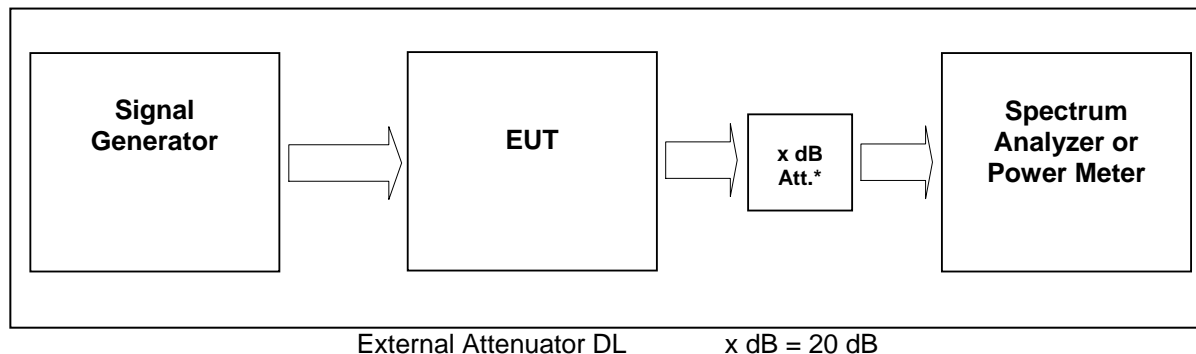

figure 5-#1 Test setup: RF Power Out: §22.913, §2.1046; IC RSS-131

Measurement uncertainty	± 0,38 dB
Test equipment used	9054, 9101,8990, 7336, 7119, 7409, 7449, 7443, 7444,

5.1 Limit

Minimum standard:

Para. No.22.913

The effective radiated power (ERP) of transmitters in the Cellular Radiotelephone

Service must not exceed the limits in this section.

(a) *Maximum ERP.* In general, the effective radiated power (ERP) of base transmitters and cellular repeaters must not exceed 500 Watts. However, for those systems operating in areas more than 72 km (45 miles) from international borders that:

(1) Are located in counties with population densities of 100 persons or fewer per square mile, based upon the most recently available population statistics from the Bureau of the Census; or,

(2) Extend coverage on a secondary basis into cellular unserved areas, as those areas are defined in § 22.949, the ERP of base transmitters and cellular repeaters of such systems must not exceed 1000 Watts. The ERP of mobile transmitters and auxiliary test transmitters must not exceed 7 Watts.

5.2 Test method

§ 2.1046 Measurements required: RF power output.

(a) For transmitters other than single sideband, independent sideband and controlled carrier radiotelephone, power output shall be measured at the RF output terminals when the transmitter is adjusted in accordance with the tune-up procedure to give the values of current and voltage on the circuit elements specified in § 2.1033(c)(8). The electrical characteristics of the radio frequency load attached to the output terminals when this test is made shall be stated.

(c) For measurements conducted pursuant to paragraphs (a) and (b) of this section, all calculations and methods used by the applicant for determining carrier power or peak envelope power, as appropriate, on the basis of measured power in the radio frequency load attached to the transmitter output terminals shall be shown. Under the test conditions specified, no components of the emission spectrum shall exceed the limits specified in the applicable rule parts as necessary for meeting occupied bandwidth or emission limitations

Test Report No.: 12-089

FCC ID: XS5-M7785HP19P

IC ID: 2237E-M7785HP19P



5.3 Test Results

Detector RMS.

Test signal Analog:

FM signal with 3.0 kHz deviation and 2.5 kHz rate and sine waveform

Test signal GSM:

Signal waveform with GMSK modulation in all time slots according to 3GPP TS45.004

Test signal GSM EDGE:

Signal waveform with 8-PSK modulation in all time slots according to 3GPP TS45.004

Test signal CDMA

Signal waveform according to table 6.2-1 of standard specification 3GPP2 C.p0051-0 v1.0 16.February 2006 pilot, sync, paging, 37 traffics, which is equal to the table 6.5.2.1 of 3GPP2 C.S0010-C v2.0 24.February 2006.

Test signal WCDMA

Signal waveform according to Test Model 1 of standard specification 3GPP TS25.141. Signal modulated with a combination of PCCPCH, SCCPCH and Dedicated Physical Channels specified as test model 1 64 DPCH.

Test signal LTE:

Signal waveform according to E-TM 3.1 widest possible bandwidth of standard specification 3GPP TS36.141



5.3.1 Downlink

Modulation	Measured at		RBW VBW Span	RF Power [dBm]	RF Power [W]	Plot -
Analog	Middle	881,5 MHz	0.1MHz 0.3MHz 1.5MHz	45.5	35.5	5.3.1.1 #1
GSM	Middle	881,5 MHz	1MHz 3MHz 10MHz	45.5	35.5	5.3.1.2 #1
EDGE	Middle	881,5 MHz	1MHz 3MHz 10MHz	45.5	35.5	5.3.1.3 #1
CDMA	Middle	881,5 MHz	3MHz 10MHz 15MHz	45.5	35.5	5.3.1.4 #1
WCDMA	Middle	881,5 MHz	10MHz 10MHz 50MHz	45.5	35.5	5.3.1.5 #1
CDMA	Middle	881,5 MHz	3MHz 10MHz 15MHz	45.5	35.5	5.3.1.6 #1
Maximum output power = 45.5 dBm = 39.8 W						
Limit Maximum output power = 57 dBm = 500 W						

table 5.3.1-#1 RF Power Out: §22.913, §2.1046; IC RSS-131 Test Results Downlink

The max RF Power out is 45.5 dBm, so the maximum antenna gain (x) can be calculated as follow:

Limit = 500W (erp) = 57 dBm

57 dBm > 45.5 dBm + x

14.5 dBd = 13.65 dBi > x

=> The antenna that will use for the complete system have to have a gain lower than 13.65 dBi, relative to a dipol.

Modulation	Pin / dBm (Ref. point B)
Analog	9.1
GSM	9.1
EDGE	9.2
CDMA	9.1
WCDMA	9.1
LTE	9.1

table 5.3.1-#2 RF Power Out: §22.913, §2.1046; IC RSS-131 Test Results Downlink Input power



5.3.1.1 Analog

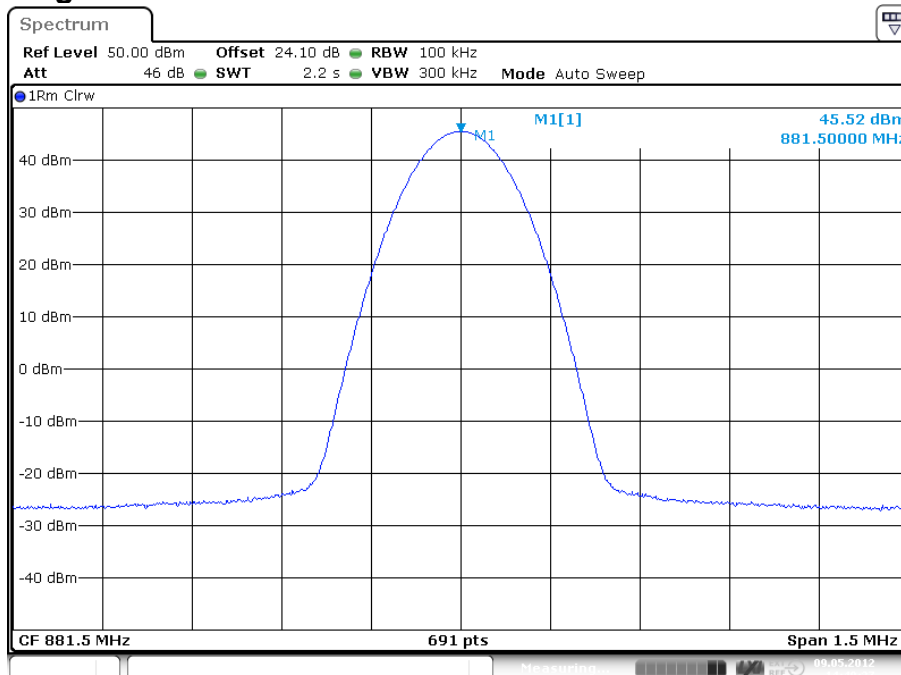

Date: 9.MAY.2012 14:49:37

plot 5.3.1.1-#1 RF Power Out: §22.913, §2.1046; IC RSS-131; Test Results; Downlink; Analog Middle

5.3.1.2 GSM

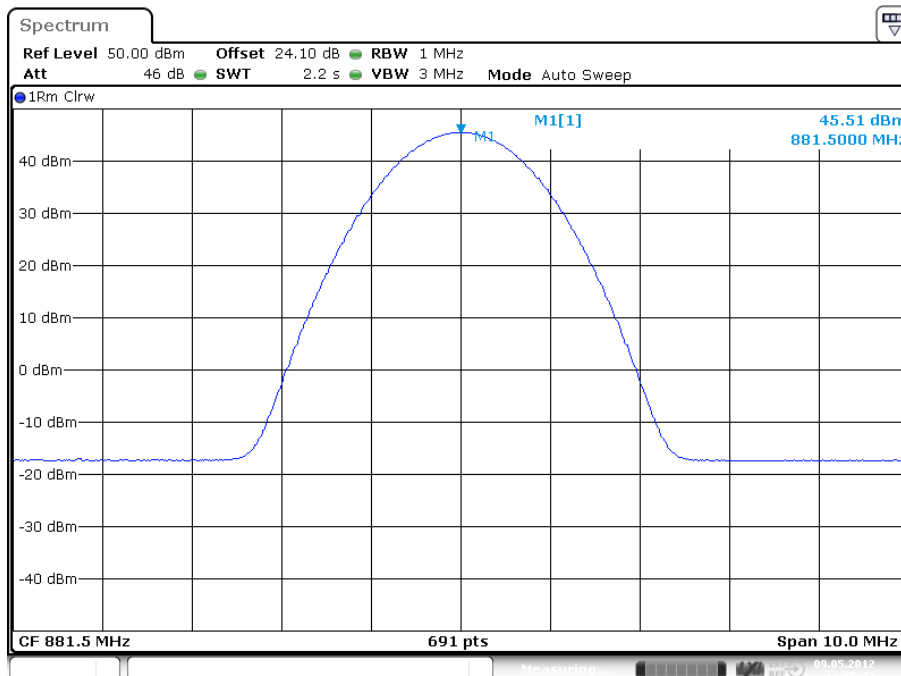

Date: 9.MAY.2012 14:56:42

plot 5.3.1.2-#1 RF Power Out: §22.913, §2.1046; IC RSS-131; Test Results; Downlink; GSM Middle



5.3.1.3 EDGE

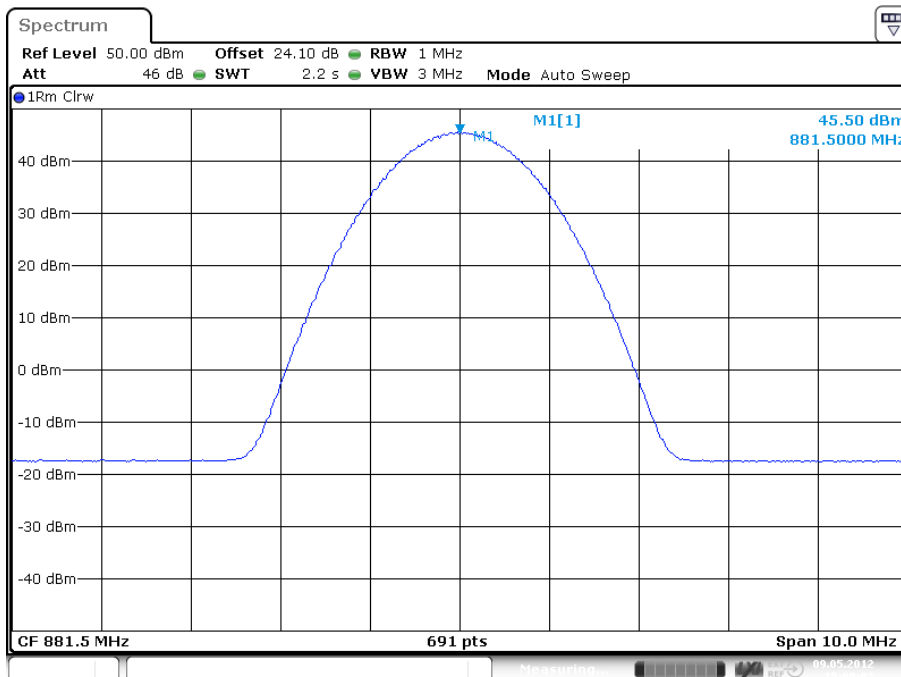

Date: 9.MAY.2012 15:00:03

plot 5.3.1.3-#1 RF Power Out: §22.913, §2.1046; IC RSS-131; Test Results; Downlink; EDGE Middle

5.3.1.4 CDMA

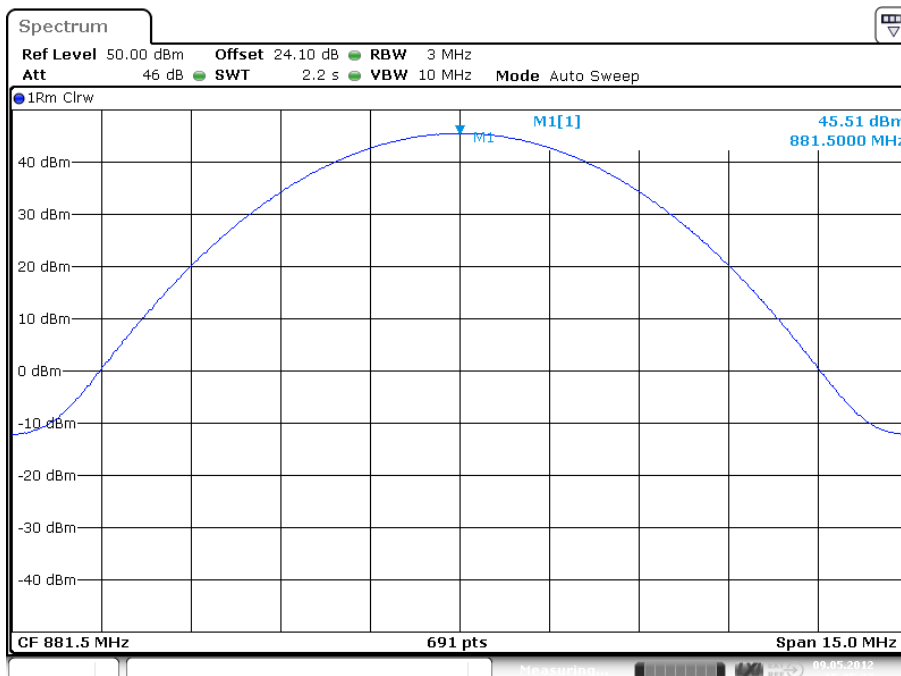

Date: 9.MAY.2012 15:05:27

plot 5.3.1.4-#1 RF Power Out: §22.913, §2.1046; IC RSS-131; Test Results; Downlink; CDMA Middle



5.3.1.5 WCDMA

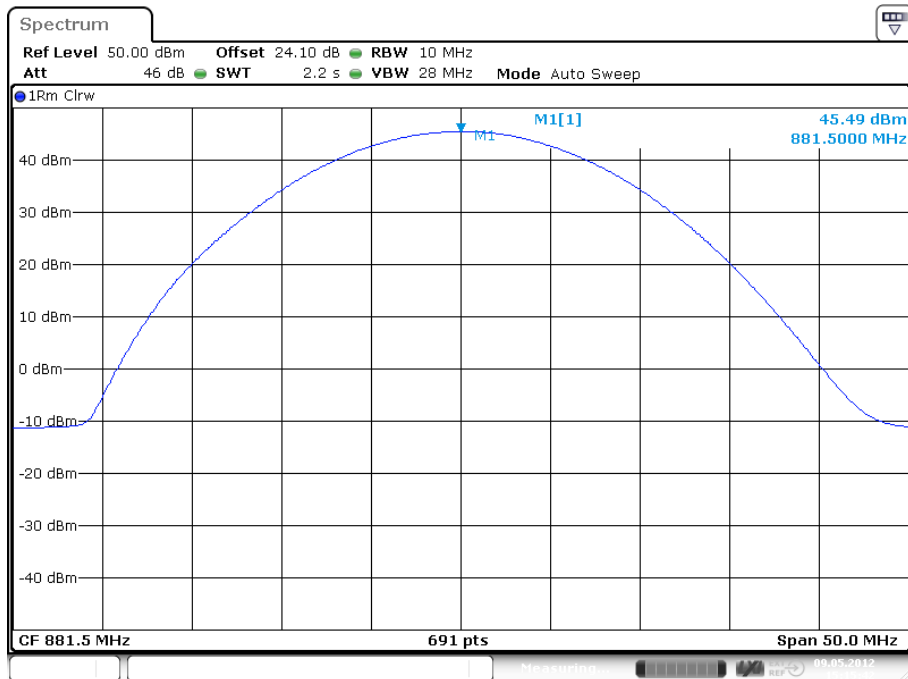

plot 5.3.1.5-#1 RF Power Out: §22.913, §2.1046; IC RSS-131; Test Results; Downlink; WCDMA Middle

5.3.1.6 LTE

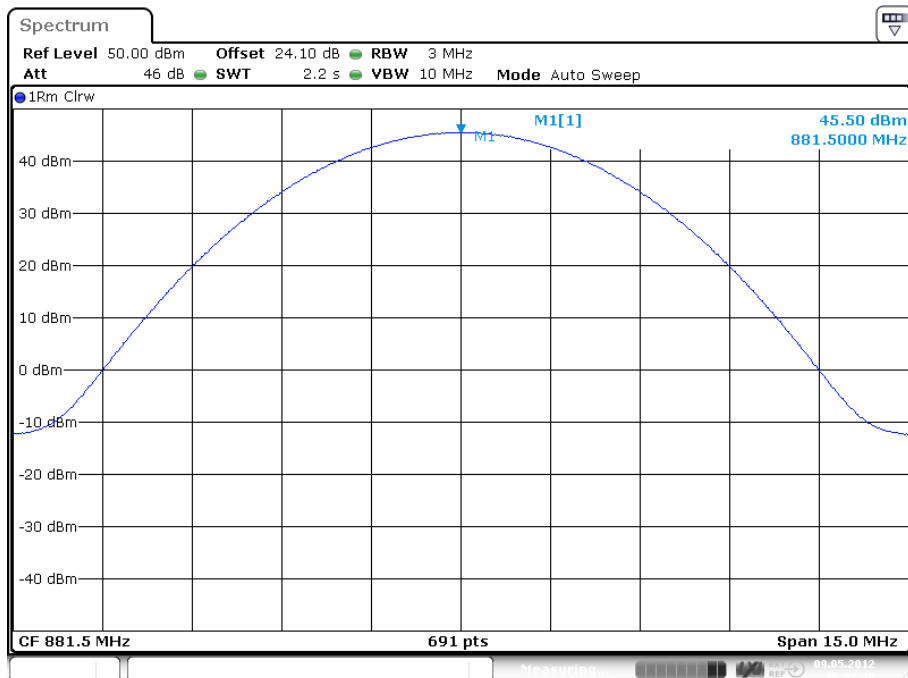

plot 5.3.1.6-#1 RF Power Out: §22.913, §2.1046; IC RSS-131; Test Results; Downlink; LTE Middle

Test Report No.: 12-089

FCC ID: XS5-M7785HP19P

IC ID: 2237E-M7785HP19P



5.3.2 Uplink

n.a.

Note: The EUT does not transmit over the air in the uplink direction.

5.4 Summary test result

Test result	complies, according the plots above
Tested by:	M. Leinfelder
Date:	09.05.2012



6 Occupied Bandwidth: §2.1049; RSS-GEN

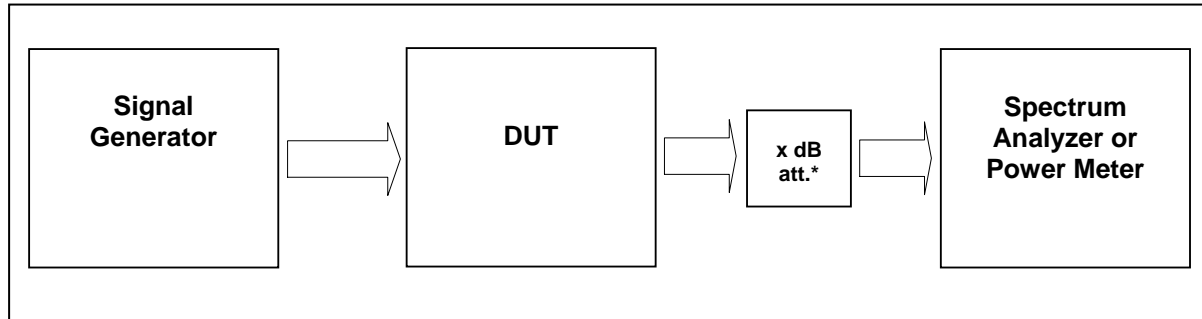

External Attenuator DL x dB = 20 dB
figure 6-#1 Test setup: Occupied Bandwidth: §2.1049; RSS-GEN

Measurement uncertainty	± 0,38 dB
Test equipment used	9054, 9101,8990, 7336, 7119, 7409, 7449, 7443, 7444,

6.1 Limit

The spectral shape of the output should look similar to input for all modulations.

6.2 Test method

Para. No.2.1049

The occupied bandwidth, that is the frequency bandwidth such that, below its lower and above its upper frequency limits, the mean powers radiated are each equal to 0.5 percent of the total mean power radiated by a given emission shall be measured under the following conditions as applicable:

6.3 Test results

For composite power measurements: Detector RMS.



6.3.1 Downlink

Modulation	Measured at		RBW VBW Span	Occupied Bandwidth	Plot #
Analog	Middle	881,5 MHz	1 kHz 10 kHz 125 kHz	10.85 kHz	6.3.1.1 #1, #2
GSM	Middle	881,5 MHz	3 kHz 30 kHz 1 MHz	242 kHz	6.3.1.2 #1, #2
EDGE	Middle	881,5 MHz	3 kHz 30 kHz 1 MHz	246 kHz	6.3.1.3 #1, #2
CDMA	Middle	881,5 MHz	30 kHz 300 kHz 5 MHz	1.24 MHz	6.3.1.4 #1, #2
WCDMA	Middle	881,5 MHz	100 kHz 1 MHz 10 MHz	4.17 MHz	6.3.1.5 #1, #2
LTE	Middle	881,5 MHz	30 kHz 300 kHz 5 MHz	1.1 MHz	6.3.1.6 #1, #2

table 6.3-#1 Occupied Bandwidth: §2.1049; RSS-GEN Test results



6.3.1.1 Analog



plot 6.3.1.1-#1 Occupied Bandwidth: \$2.1049; RSS-GEN; Test results; Downlink; Analog Output

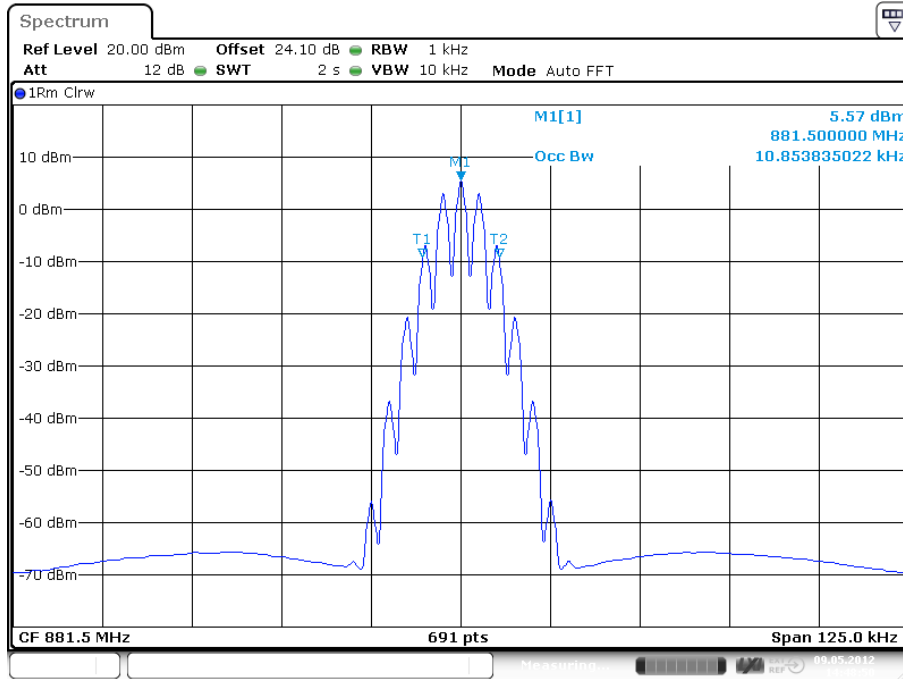

plot 6.3.1.1-#2 Occupied Bandwidth: \$2.1049; RSS-GEN; Test results; Downlink; Analog Input



6.3.1.2 GSM

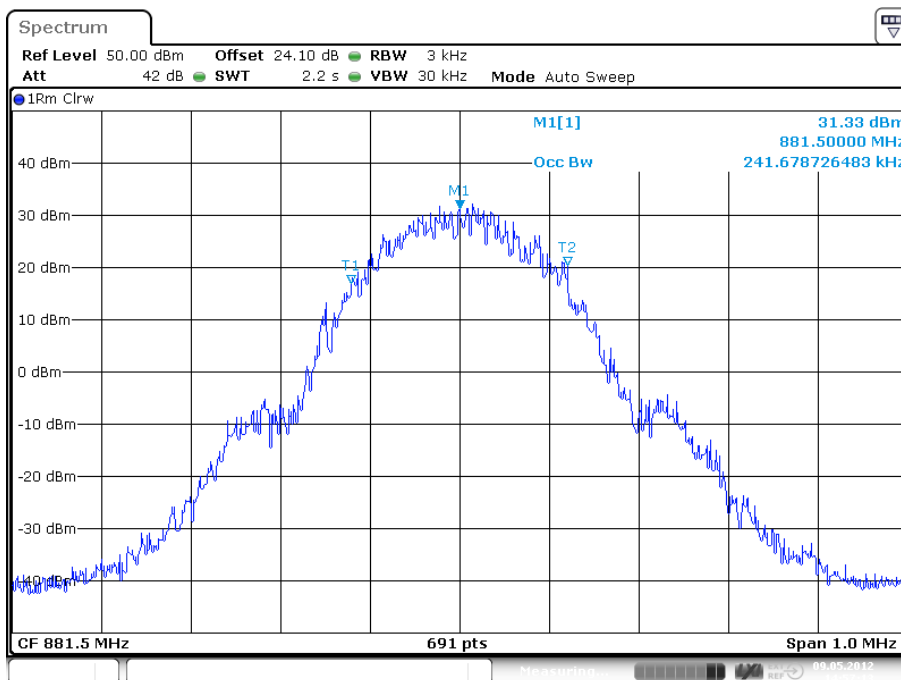

Date: 9.MAY.2012 14:57:13

plot 6.3.1.2-#1 Occupied Bandwidth: §2.1049; RSS-GEN; Test results; Downlink; GSM Output

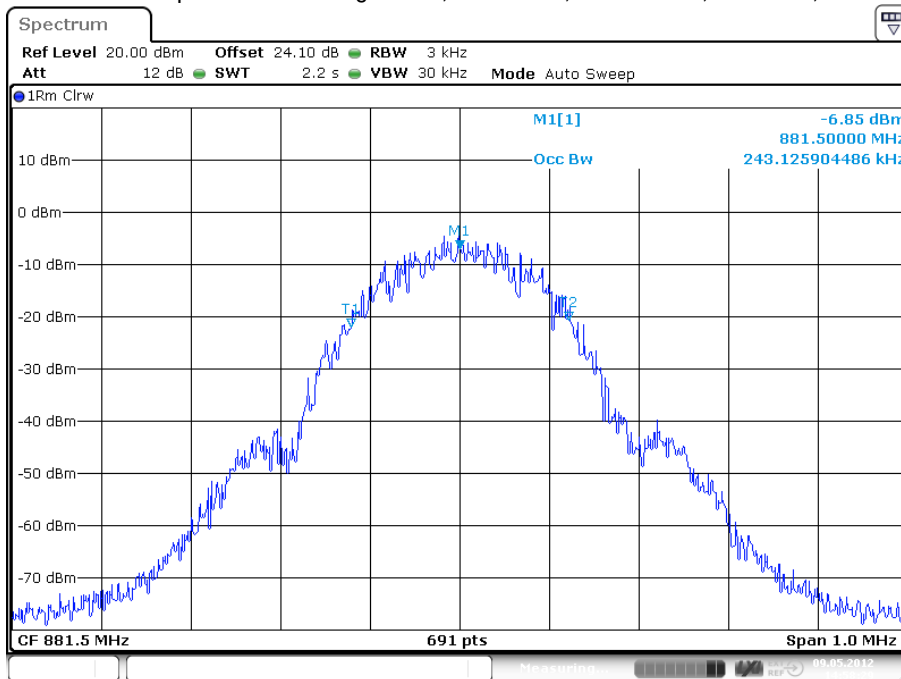

Date: 9.MAY.2012 14:58:29

plot 6.3.1.2-#2 Occupied Bandwidth: §2.1049; RSS-GEN; Test results; Downlink; GSM Input



6.3.1.3 EDGE

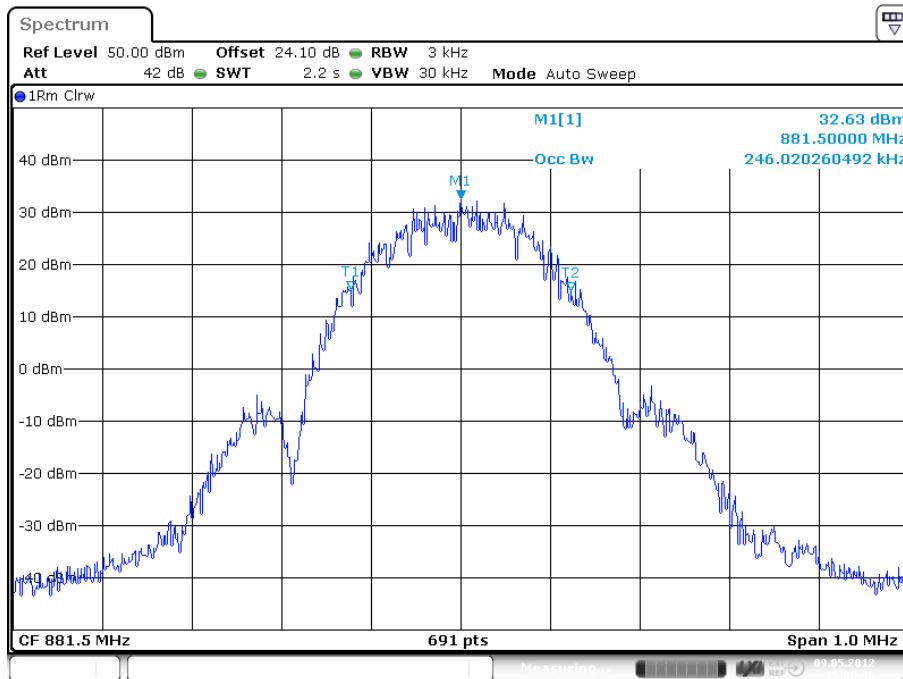

Date: 9.MAY.2012 15:00:40

plot 6.3.1.3-#1 Occupied Bandwidth: §2.1049; RSS-GEN; Test results; Downlink; EDGE Output

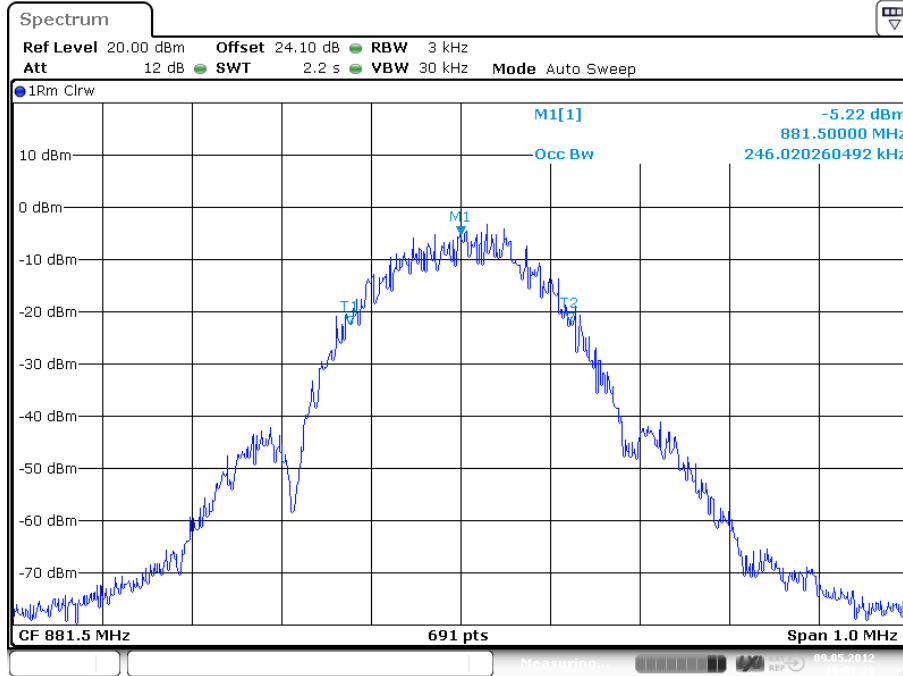

Date: 9.MAY.2012 15:01:29

plot 6.3.1.3-#2 Occupied Bandwidth: §2.1049; RSS-GEN; Test results; Downlink; EDGE Input



6.3.1.4 CDMA

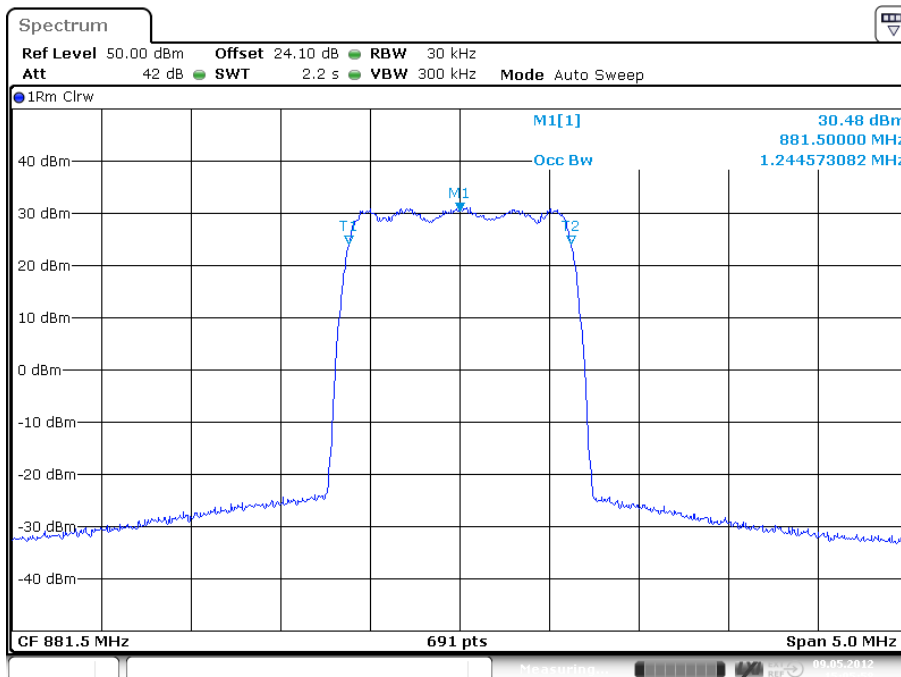

plot 6.3.1.4-#1 Occupied Bandwidth: §2.1049; RSS-GEN; Test results; Downlink; CDMA Output

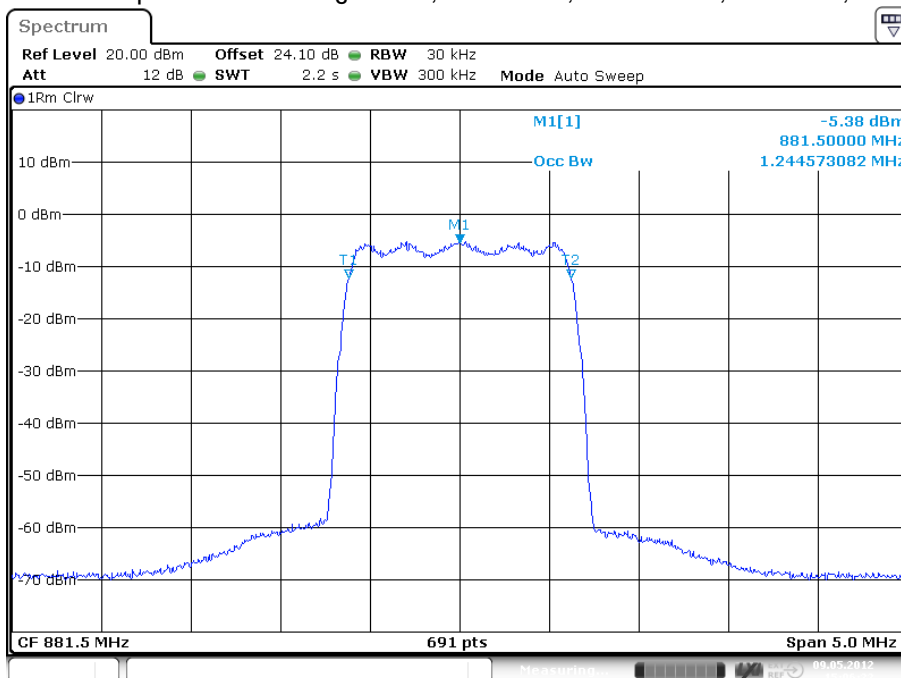

plot 6.3.1.4-#2 Occupied Bandwidth: §2.1049; RSS-GEN; Test results; Downlink; CDMA Input



6.3.1.5 WCDMA

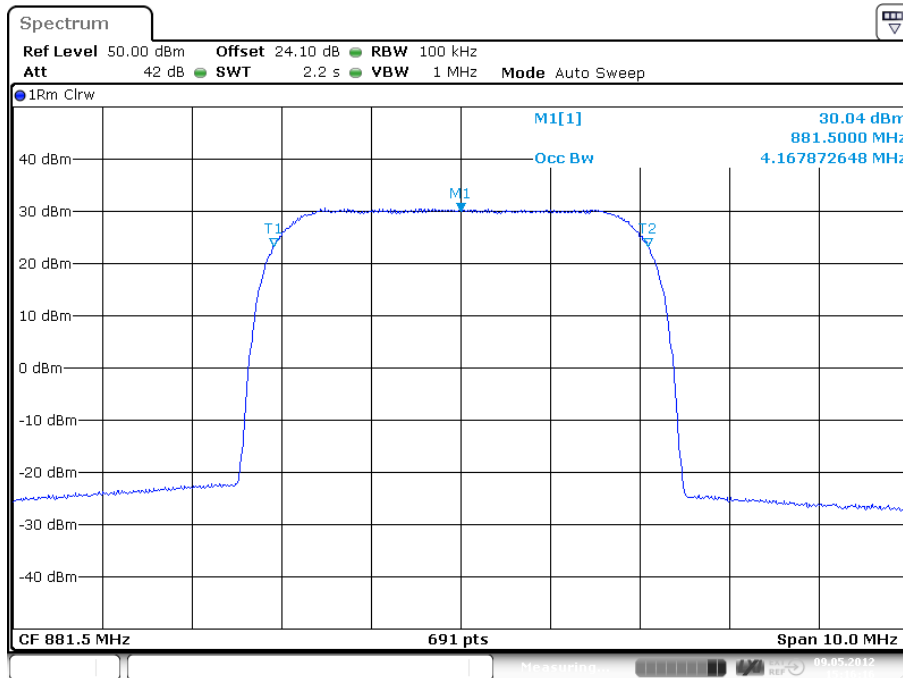

Date: 9.MAY.2012 15:16:16

plot 6.3.1.5-#1 Occupied Bandwidth: §2.1049; RSS-GEN; Test results; Downlink; WCDMA Output

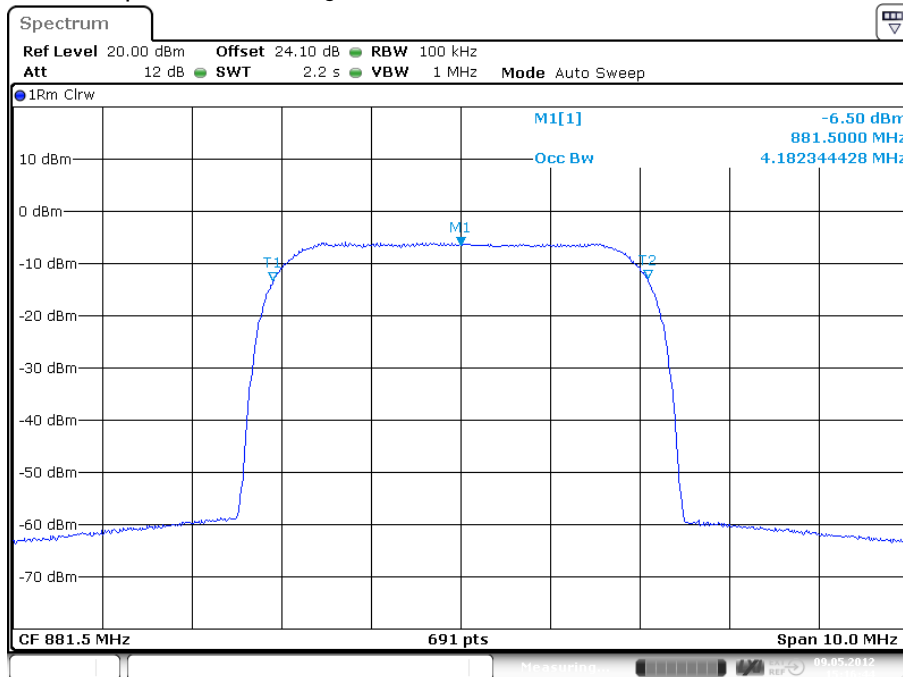

Date: 9.MAY.2012 15:16:44

plot 6.3.1.5-#2 Occupied Bandwidth: §2.1049; RSS-GEN; Test results; Downlink; WCDMA Input



6.3.1.6 LTE

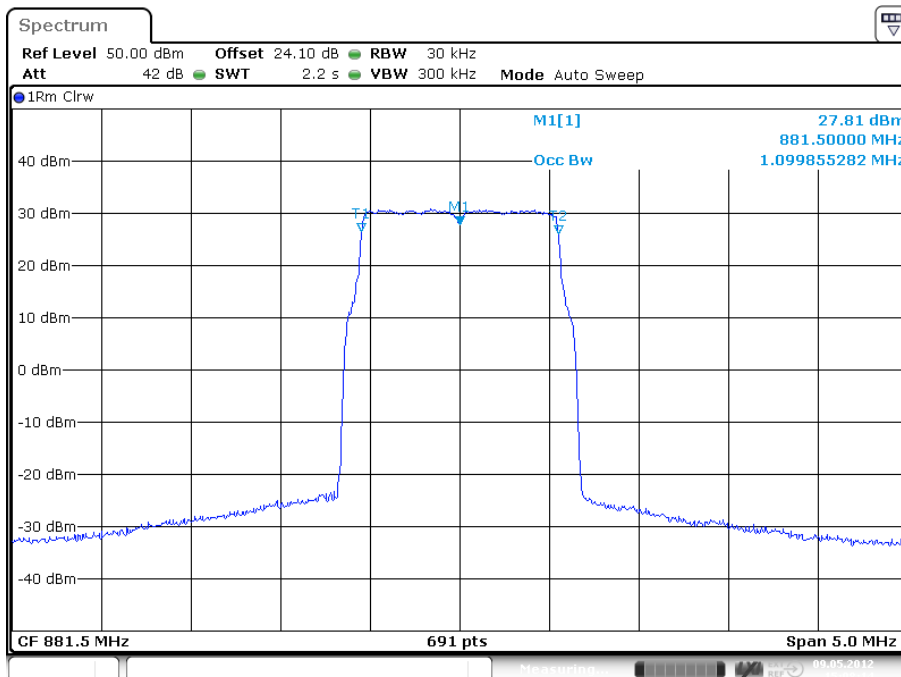

plot 6.3.1.6-#1 Occupied Bandwidth: \$2.1049; RSS-GEN; Test results; Downlink; LTE Output

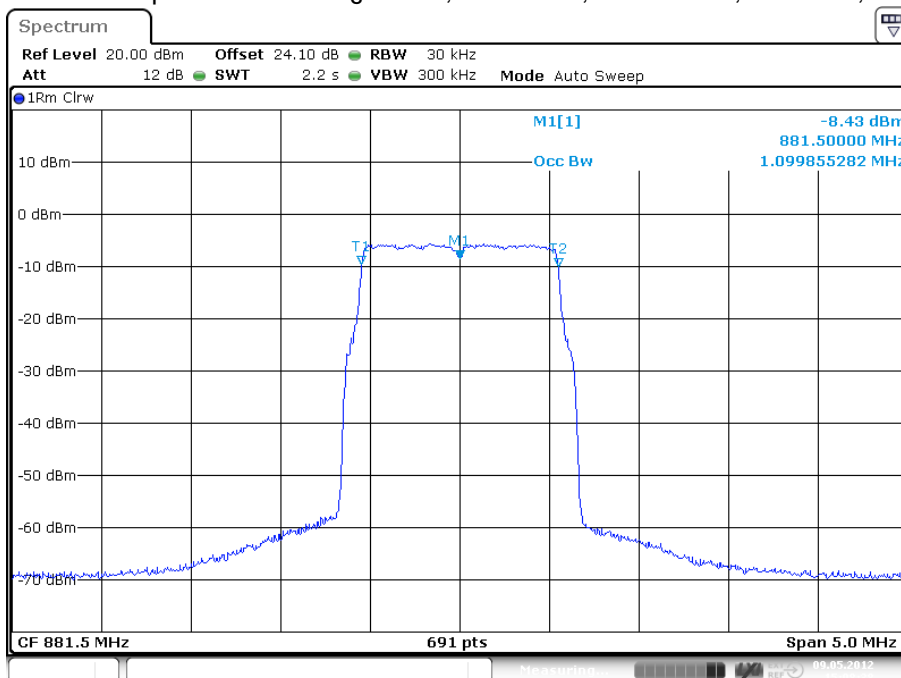

plot 6.3.1.6-#2 Occupied Bandwidth: \$2.1049; RSS-GEN; Test results; Downlink; LTE Input

Test Report No.: 12-089

FCC ID: XS5-M7785HP19P

IC ID: 2237E-M7785HP19P



6.3.2 Uplink

n.a.

Note: The EUT does not transmit over the air in the uplink direction.

6.4 Summary test result

Test result	complies, according the plots above
Tested by:	M. Leinfelder
Date:	09.05.2012



7 Spurious Emissions at Antenna Terminals: §22.917, §2.1051; RSS-131, RSS-GEN

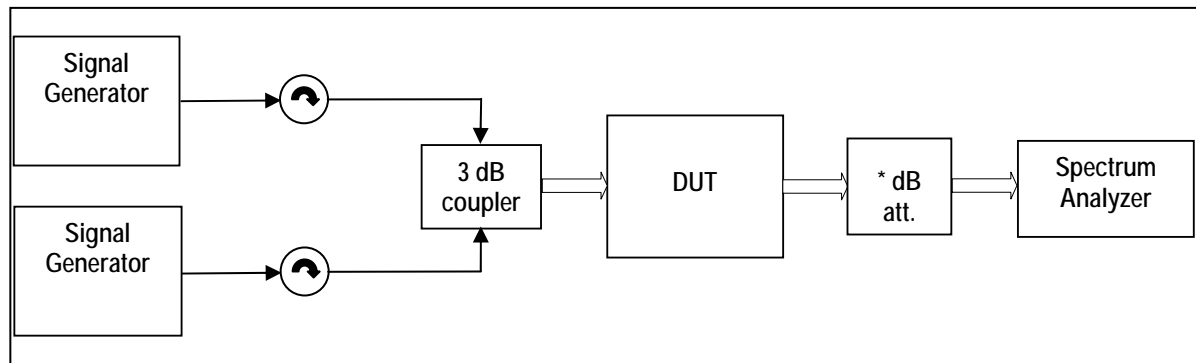

External Attenuator DL x dB = 20 dB

figure 7-#1 Test setup: Spurious Emissions at Antenna Terminals: §22.917, §2.1051; RSS-131, RSS-GEN

Measurement uncertainty	± 0,54 dB ± 1,2 dB ± 1,5 dB	9 kHz to 3 GHz 3 GHz to 7 GHz 7 GHz to 26 GHz
Test equipment used	9054, 9101,8990, 7336, 7119, 7409, 7449, 7443, 7444,	

7.1 Limit

Minimum standard:

Para. No.22.917

(a) *Out of band emissions.* The power of any emission outside of the authorized operating frequency ranges must be attenuated below the transmitting power (P) by a factor of at least $43 + 10 \log(P)$ dB.

(b) *Measurement procedure.* Compliance with these rules is based on the use of measurement instrumentation employing a resolution bandwidth of 100 kHz or greater. In the 1 MHz bands immediately outside and adjacent to the frequency block a resolution bandwidth of at least one percent of the emission bandwidth of the fundamental emission of the transmitter may be employed. A narrower resolution bandwidth is permitted in all cases to improve measurement accuracy provided the measured power is integrated over the full required measurement bandwidth (*i.e.* 100 kHz or 1 percent of emission bandwidth, as specified). The emission bandwidth is defined as the width of the signal between two points, one below the carrier center frequency and one above the carrier center frequency, outside of which all emissions are attenuated at least 26 dB below the transmitter power.

7.2 Test method

Para. No 2.1051 Measurements required: Spurious emissions at antenna terminals.

The radio frequency voltage or powers generated within the equipment and appearing on a spurious frequency shall be checked at the equipment output terminals when properly loaded with a suitable artificial antenna. Curves or equivalent data shall show the magnitude of each harmonic and other spurious emission that can be detected when the equipment is operated under the conditions specified in § 2.1049 as appropriate. The magnitude of spurious emissions which are attenuated more than 20 dB below the permissible value need not be specified.

[39 FR 5919, Feb. 15, 1974. Redesignated and amended at 63 FR 36599, July 7, 1998]



7.3 Test results

7.3.1 Downlink

<1MHz from Band Edge

Detector: RMS.

Modulation	Measured at Band Edge	Carriers	RBW VBW Span Sweep points	Max. level (dBm)	Plot -
Analog	Lower Edge Upper Edge	869,0125 MHz 869,0375 MHz 893,9625 MHz 893,9875 MHz	0.3kHz 3kHz 1.1MHz	< -20	7.3.1.1 #1 #2
GSM	Lower Edge Upper Edge	869,4 MHz 869,6 MHz 893,4 MHz 893,6 MHz	3kHz 30kHz 2MHz	< -31	7.3.1.2 #1 #2
EDGE	Lower Edge Upper Edge	869,4 MHz 869,6 MHz 893,4 MHz 893,6 MHz	3kHz 30kHz 2MHz	< -28	7.3.1.3 #1 #2
CDMA	Lower Edge Upper Edge	869,775 MHz 871,025 MHz 891,975 MHz 893,225 MHz	30kHz 300kHz 6MHz	< -23	7.3.1.4 #1 #2
WCDMA	Lower Edge Upper Edge	871,6 MHz 876,6 MHz 886,4 MHz 891,4 MHz	100kHz 1MHz 15MHz	< -20	7.3.1.5 #1 #2
LTE	Lower Edge Upper Edge	869,7 MHz 871,1 MHz 891,9 MHz 893,3 MHz	30kHz 300kHz 6MHz	< -22	7.3.1.6 #1 #2

table 7.3-#1 Spurious Emissions at Antenna Terminals: §22.917, §2.1051; RSS-131, RSS-GEN Test results <1MHz from Band Edge



>1MHz from Band Edge

Detector: RMS.

Modulation	Carrier	RBW VBW Span	Max. level (dBm)	Plot -
Analog	881,5 MHz	1MHz 3MHz 30MHz – 10GHz	< -19	7.3.1.7 #1
GSM	881,5 MHz	1MHz 3MHz 30MHz – 10GHz	< -19	7.3.1.8 #1
EDGE	881,5 MHz	1MHz 3MHz 30MHz – 10GHz	< -19	7.3.1.9 #1
CDMA	881,5 MHz	1MHz 3MHz 30MHz – 10GHz	< -18	7.3.1.10 #1
WCDMA	881,5 MHz	1MHz 3MHz 30MHz – 10GHz	< -18	7.3.1.11 #1
LTE	881,5 MHz	1MHz 3MHz 30MHz – 10GHz	< -18	7.3.1.12 #1

table 7.3-#2 Spurious Emissions at Antenna Terminals: §22.917, §2.1051; RSS-131, RSS-GEN Test results <1MHz from Band Edge



7.3.1.1 Analog < 1MHz to band edge

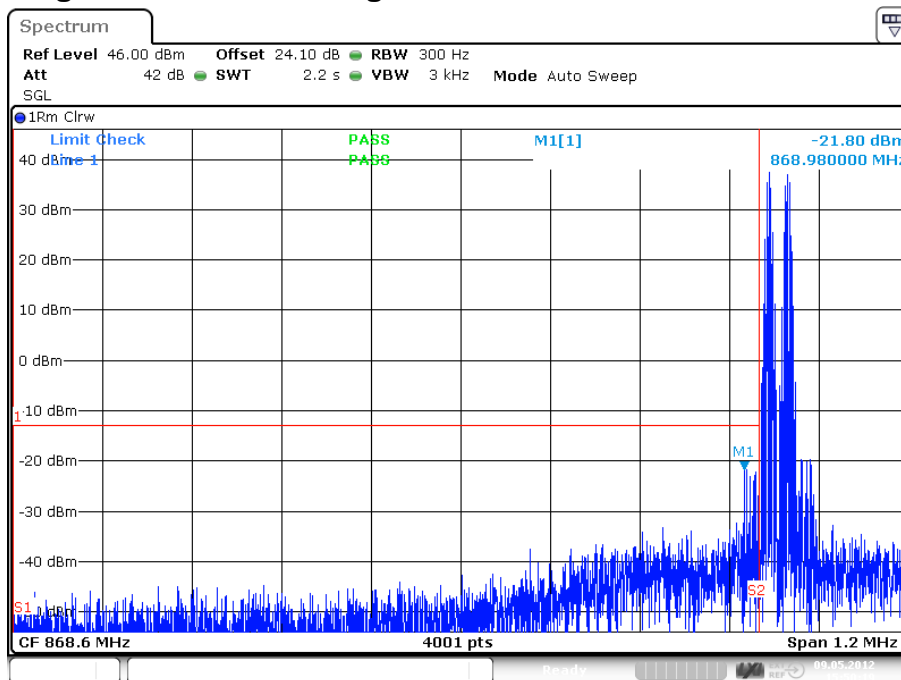

Date: 9.MAY.2012 15:50:19

plot 7.3.1.1-#1 Spurious Emissions at Antenna Terminals: §22.917, §2.1051; RSS-131, RSS-GEN; Test results; Downlink; Analog < 1MHz to band edge Lower Band Edge

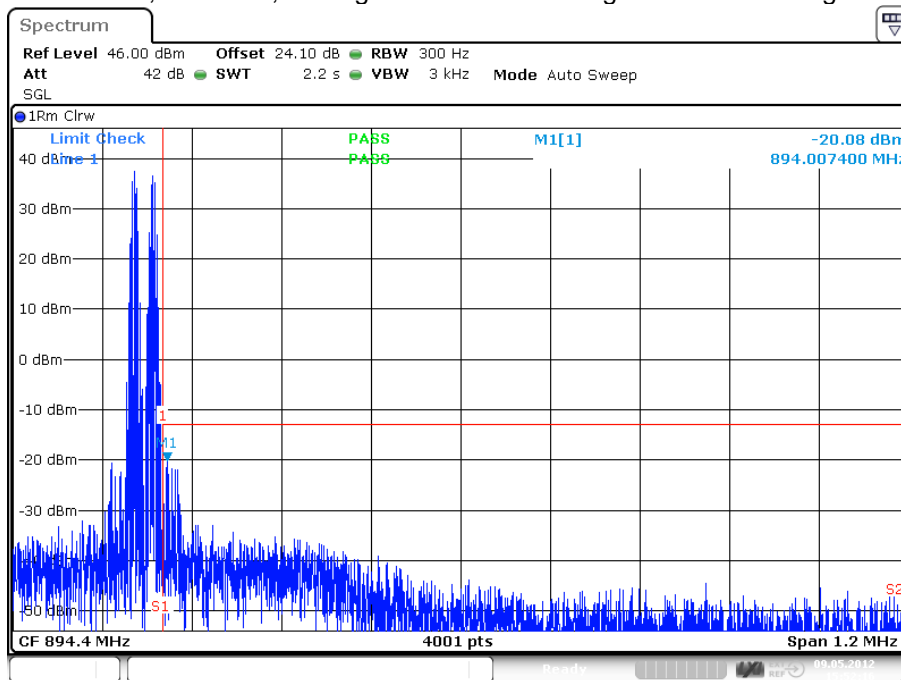

Date: 9.MAY.2012 15:52:16

plot 7.3.1.1-#2 Spurious Emissions at Antenna Terminals: §22.917, §2.1051; RSS-131, RSS-GEN; Test results; Downlink; Analog < 1MHz to band edge Upper Band Edge



7.3.1.2 GSM < 1MHz to band edge

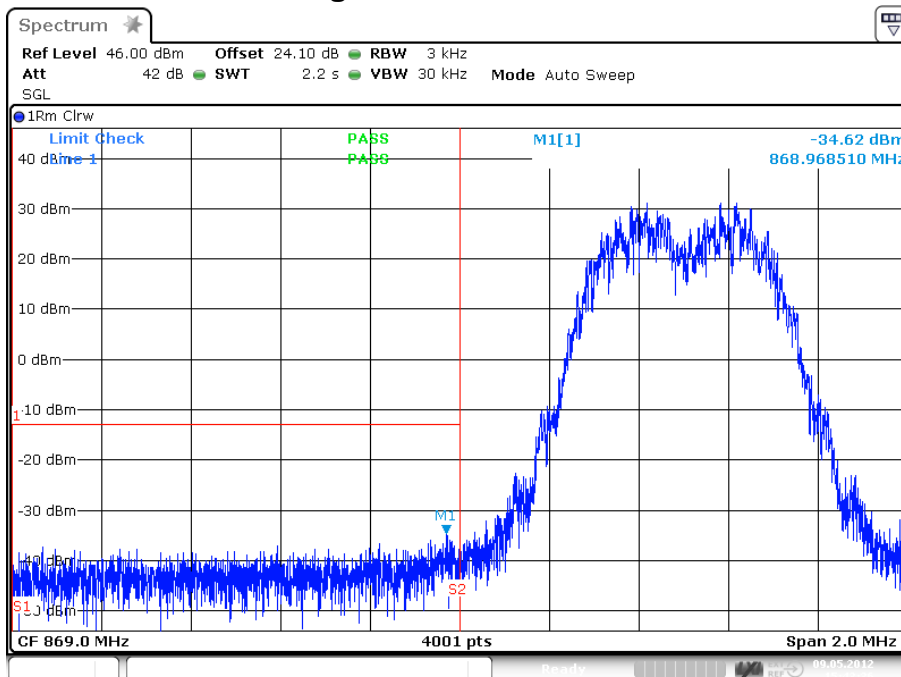

Date: 9.MAY.2012 15:43:36

plot 7.3.1.2-#1 Spurious Emissions at Antenna Terminals: §22.917, §2.1051; RSS-131, RSS-GEN; Test results; Downlink; GSM < 1MHz to band edge Lower Band Edge

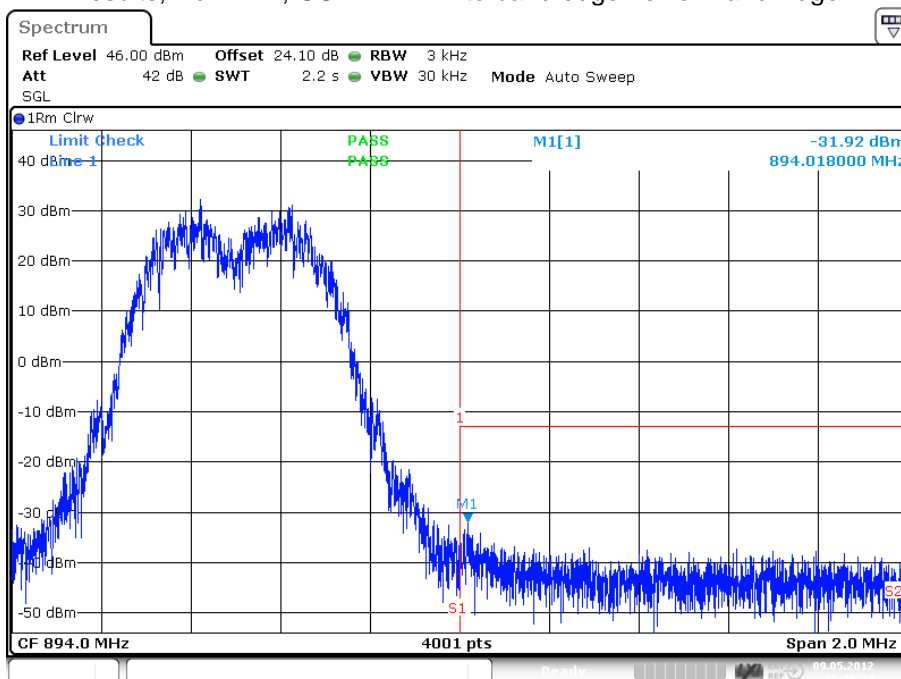

Date: 9.MAY.2012 15:40:14

plot 7.3.1.2-#2 Spurious Emissions at Antenna Terminals: §22.917, §2.1051; RSS-131, RSS-GEN; Test results; Downlink; GSM < 1MHz to band edge Upper Band Edge



7.3.1.3 EDGE < 1MHz to band edge

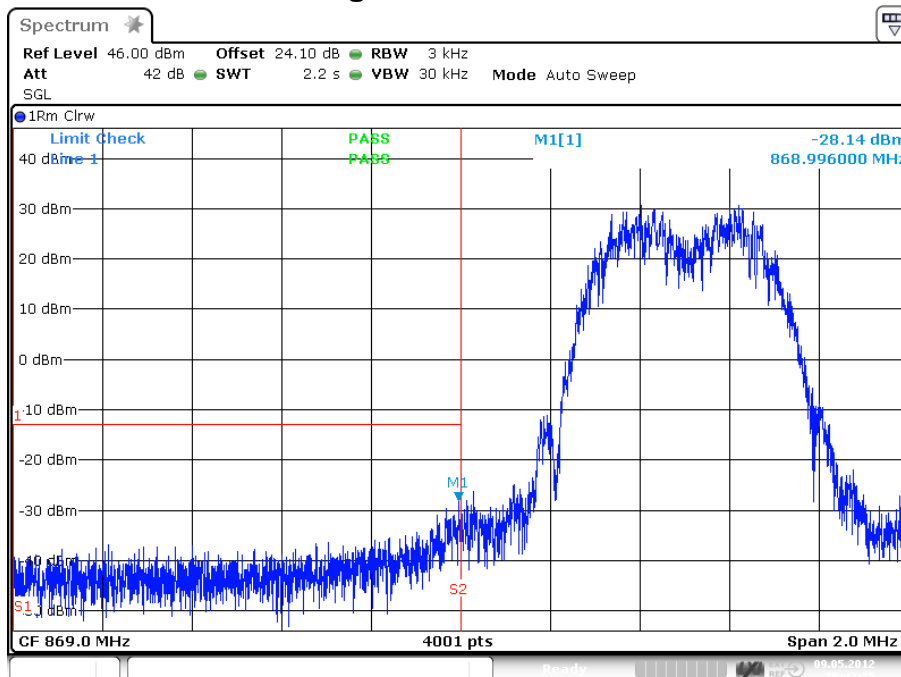

plot 7.3.1.3-#1 Spurious Emissions at Antenna Terminals: §22.917, §2.1051; RSS-131, RSS-GEN; Test results; Downlink; EDGE < 1MHz to band edge Lower Band Edge

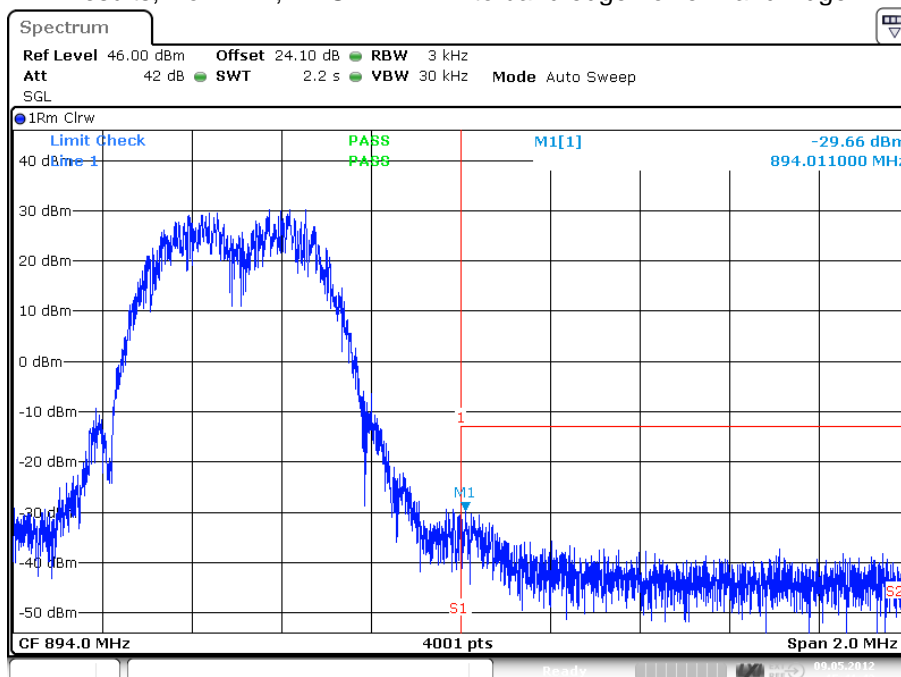

plot 7.3.1.3-#2 Spurious Emissions at Antenna Terminals: §22.917, §2.1051; RSS-131, RSS-GEN; Test results; Downlink; EDGE < 1MHz to band edge Upper Band Edge



7.3.1.4 CDMA < 1MHz to band edge

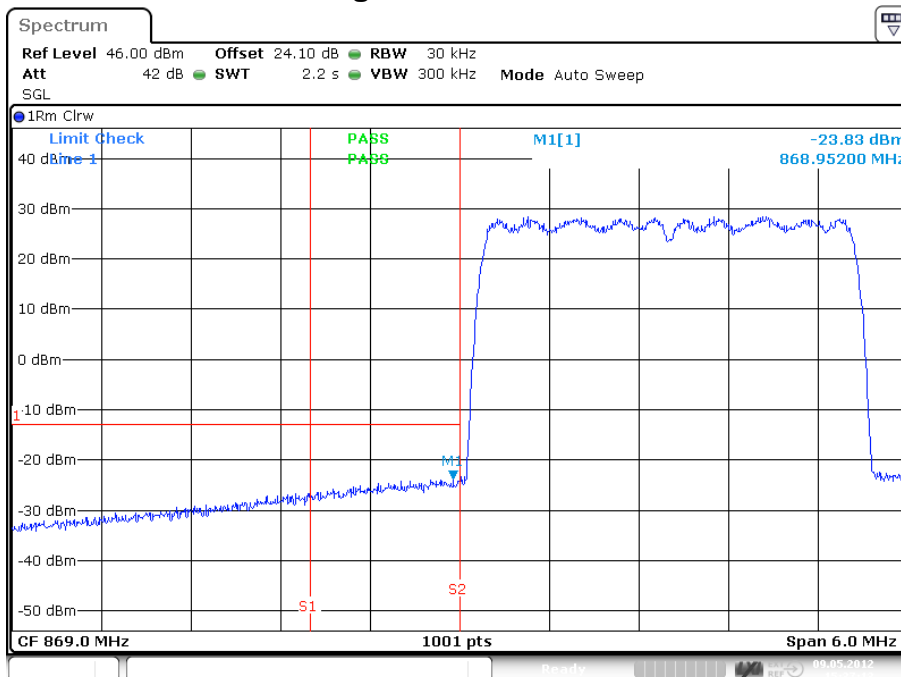

Date: 9.MAY.2012 15:37:13

plot 7.3.1.4-#1 Spurious Emissions at Antenna Terminals: §22.917, §2.1051; RSS-131, RSS-GEN; Test results; Downlink; CDMA < 1MHz to band edge Lower Band Edge

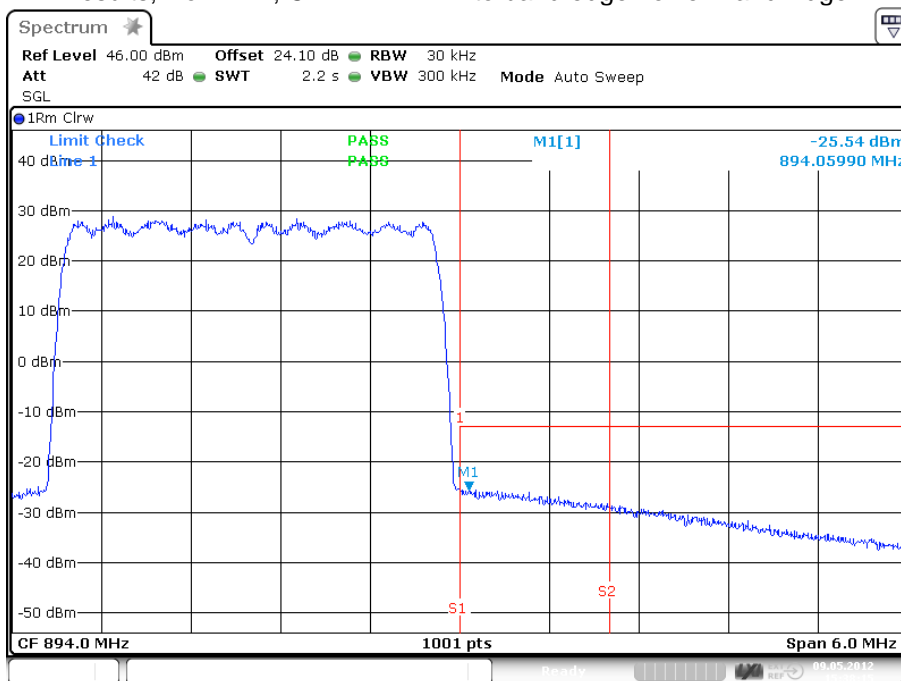

Date: 9.MAY.2012 15:38:15

plot 7.3.1.4-#2 Spurious Emissions at Antenna Terminals: §22.917, §2.1051; RSS-131, RSS-GEN; Test results; Downlink; CDMA < 1MHz to band edge Upper Band Edge



7.3.1.5 WCDMA < 1MHz to band edge

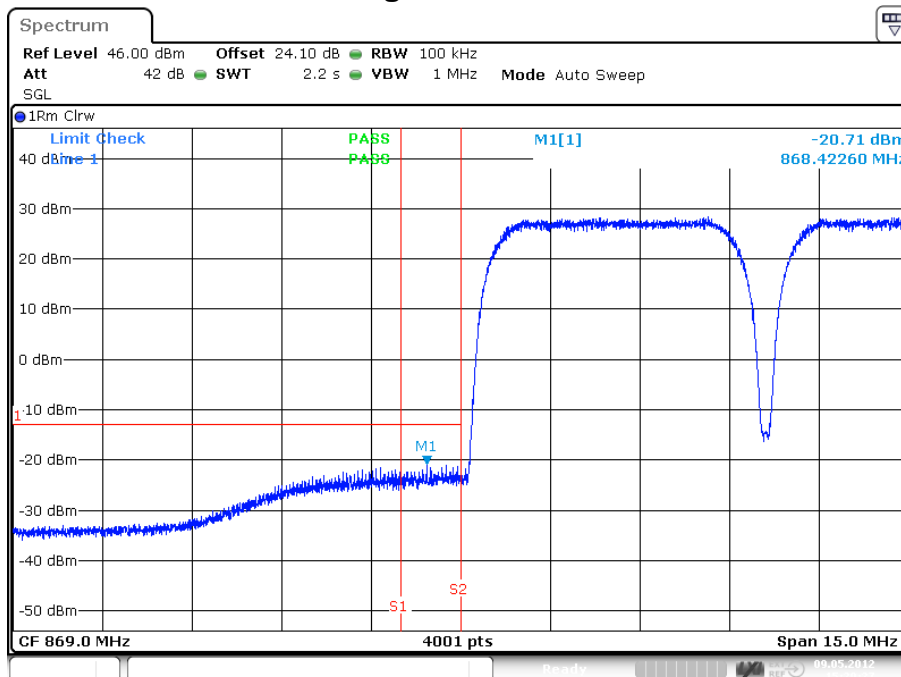

Date: 9.MAY.2012 15:29:28

plot 7.3.1.5-#1 Spurious Emissions at Antenna Terminals: §22.917, §2.1051; RSS-131, RSS-GEN; Test results; Downlink; WCDMA < 1MHz to band edge Lower Band Edge

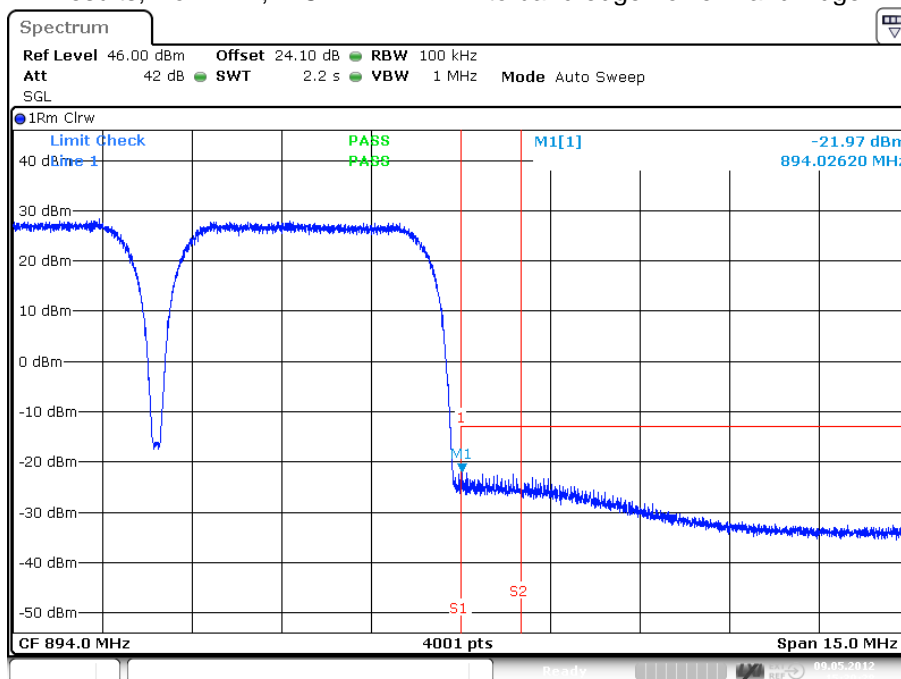

Date: 9.MAY.2012 15:30:28

plot 7.3.1.5-#2 Spurious Emissions at Antenna Terminals: §22.917, §2.1051; RSS-131, RSS-GEN; Test results; Downlink; WCDMA < 1MHz to band edge Upper Band Edge



7.3.1.6 LTE < 1MHz to band edge

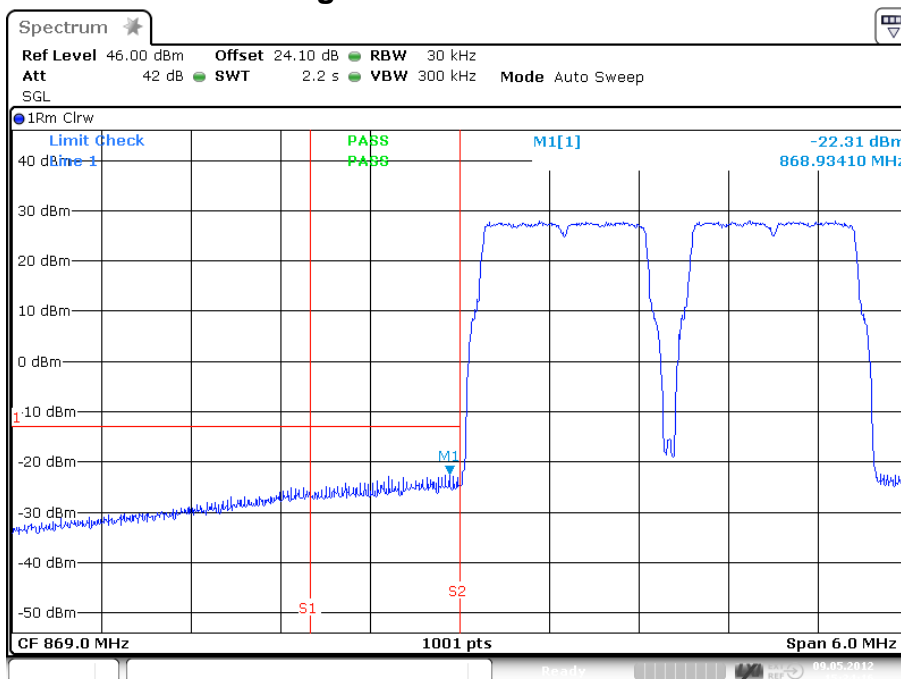

Date: 9.MAY.2012 15:34:17

plot 7.3.1.6-#1 Spurious Emissions at Antenna Terminals: §22.917, §2.1051; RSS-131, RSS-GEN; Test results; Downlink; LTE < 1MHz to band edge Lower Band Edge

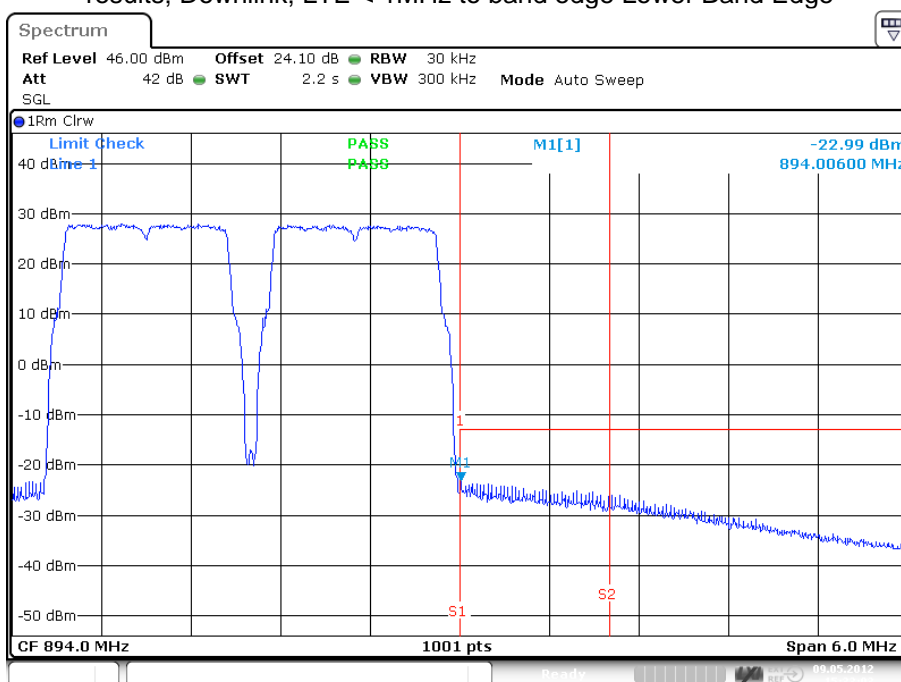

Date: 9.MAY.2012 15:33:03

plot 7.3.1.6-#2 Spurious Emissions at Antenna Terminals: §22.917, §2.1051; RSS-131, RSS-GEN; Test results; Downlink; LTE < 1MHz to band edge Upper Band Edge



7.3.1.7 Analog > 1MHz to band edge

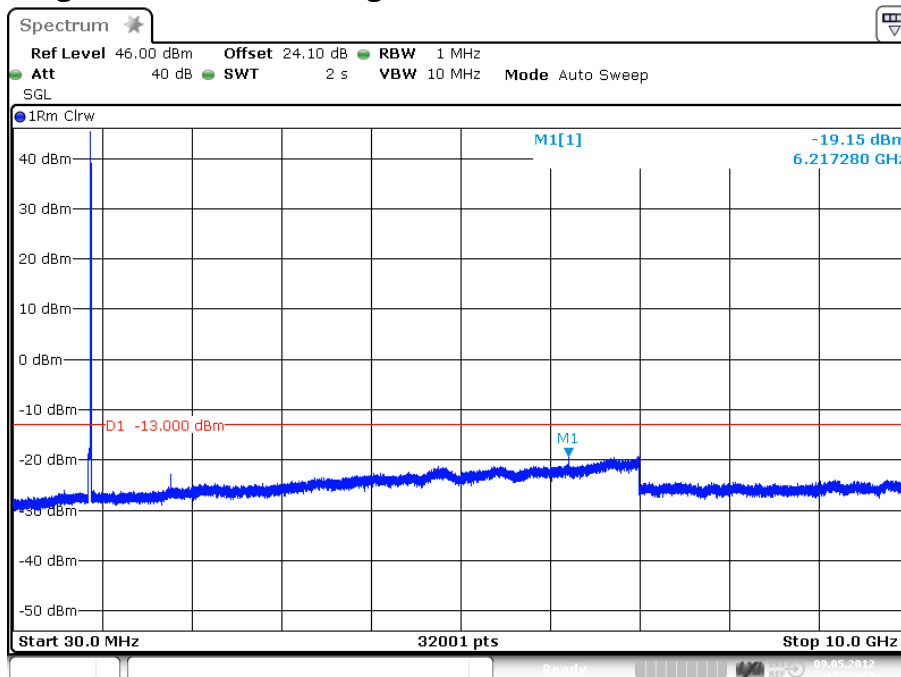

Date: 9.MAY.2012 15:56:32

plot 7.3.1.7-#1 Spurious Emissions at Antenna Terminals: §22.917, §2.1051; RSS-131, RSS-GEN; Test results; Downlink; Analog > 1MHz to band edge; carrier (881,5MHz) notched

7.3.1.8 GSM > 1MHz to band edge

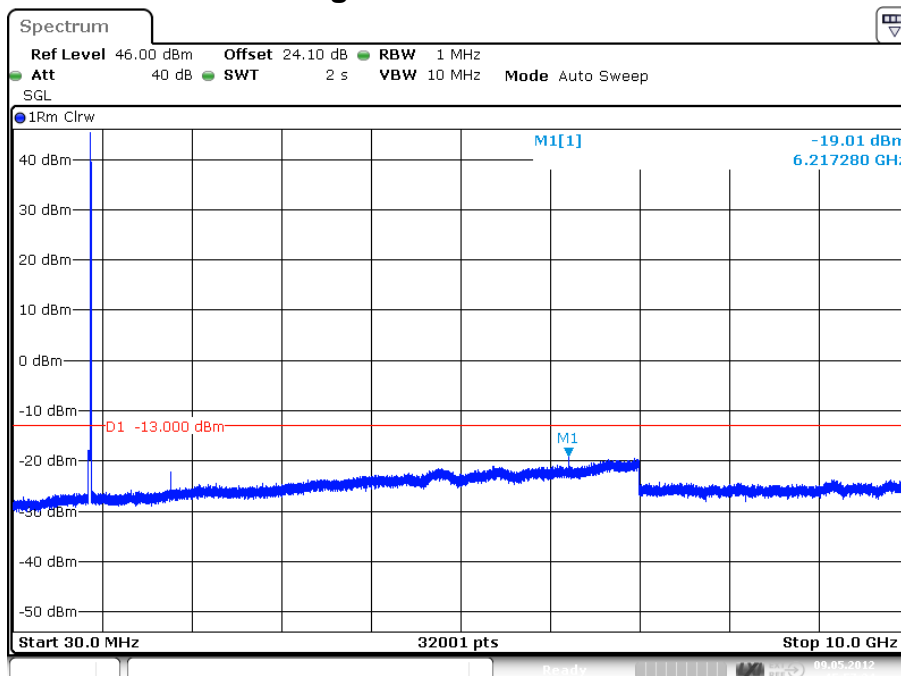

Date: 9.MAY.2012 15:57:24

plot 7.3.1.8-#1 Spurious Emissions at Antenna Terminals: §22.917, §2.1051; RSS-131, RSS-GEN; Test results; Downlink; GSM > 1MHz to band edge; carrier (881,5MHz) notched



7.3.1.9 EDGE > 1MHz to band edge

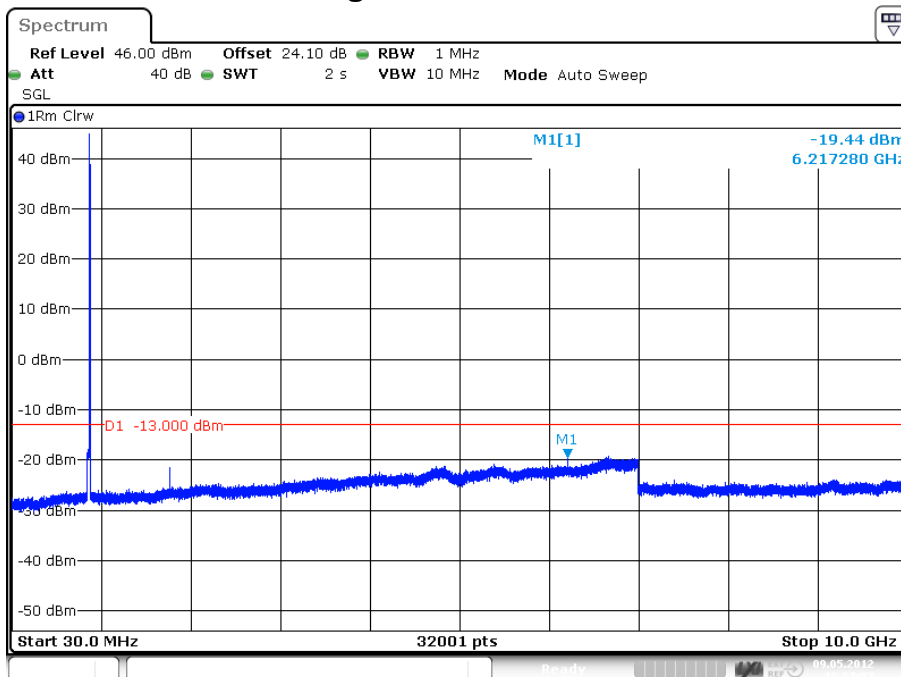

Date: 9.MAY.2012 15:57:58

plot 7.3.1.9-#1 Spurious Emissions at Antenna Terminals: §22.917, §2.1051; RSS-131, RSS-GEN; Test results; Downlink; EDGE > 1MHz to band edge; carrier (881,5MHz) notched

7.3.1.10 CDMA > 1MHz to band edge

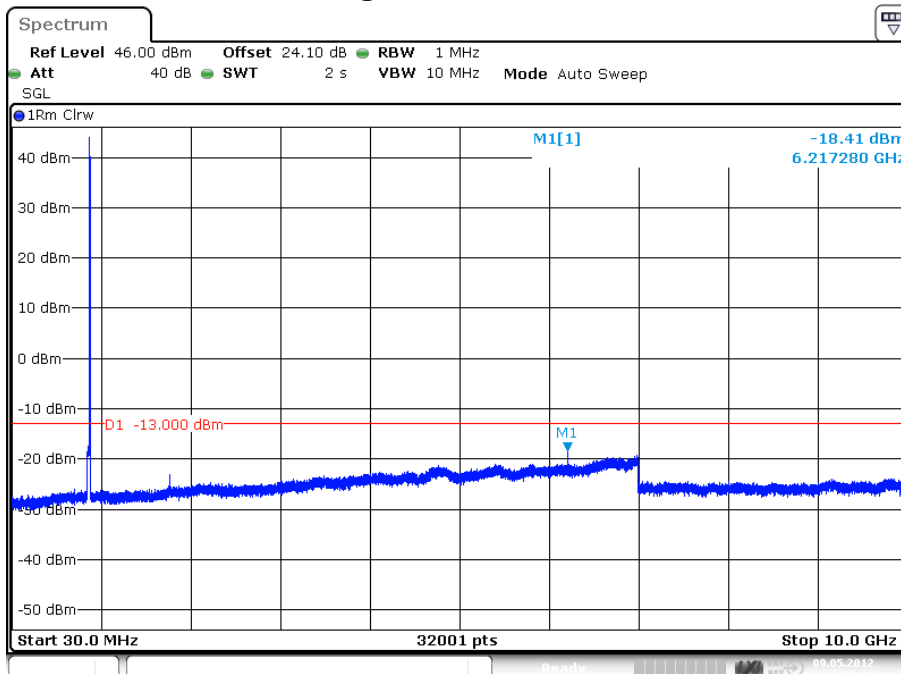

Date: 9.MAY.2012 15:58:38

plot 7.3.1.10-#1 Spurious Emissions at Antenna Terminals: §22.917, §2.1051; RSS-131, RSS-GEN; Test results; Downlink; CDMA > 1MHz to band edge; carrier (881,5MHz) notched



7.3.1.11 WCDMA > 1MHz to band edge

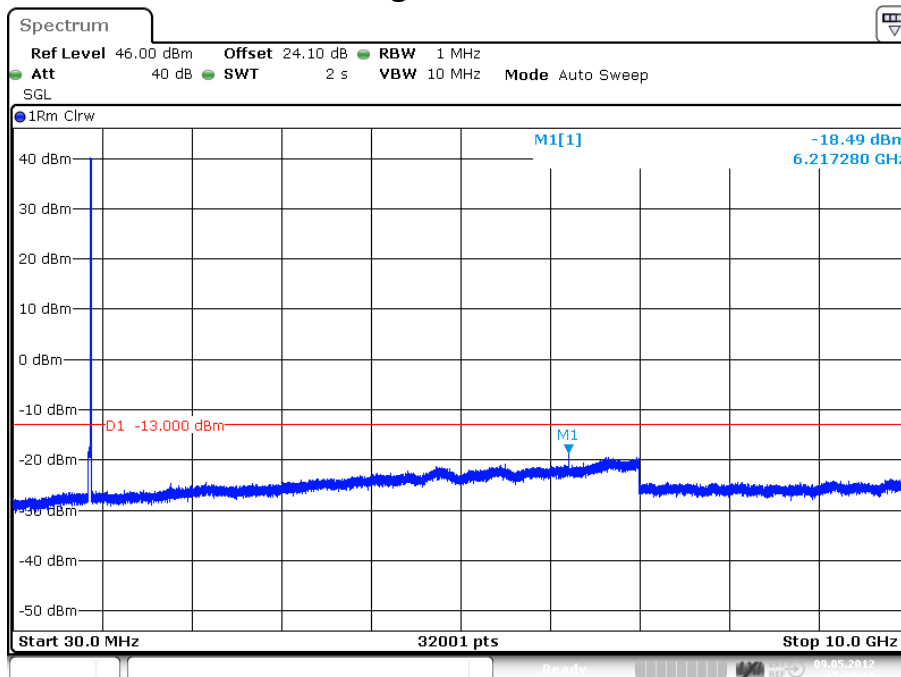

Date: 9.MAY.2012 15:59:11

plot 7.3.1.11-#1 Spurious Emissions at Antenna Terminals: §22.917, §2.1051; RSS-131, RSS-GEN; Test results; Downlink; WCDMA > 1MHz to band edge; carrier (881,5MHz) notched

7.3.1.12 LTE > 1MHz to band edge

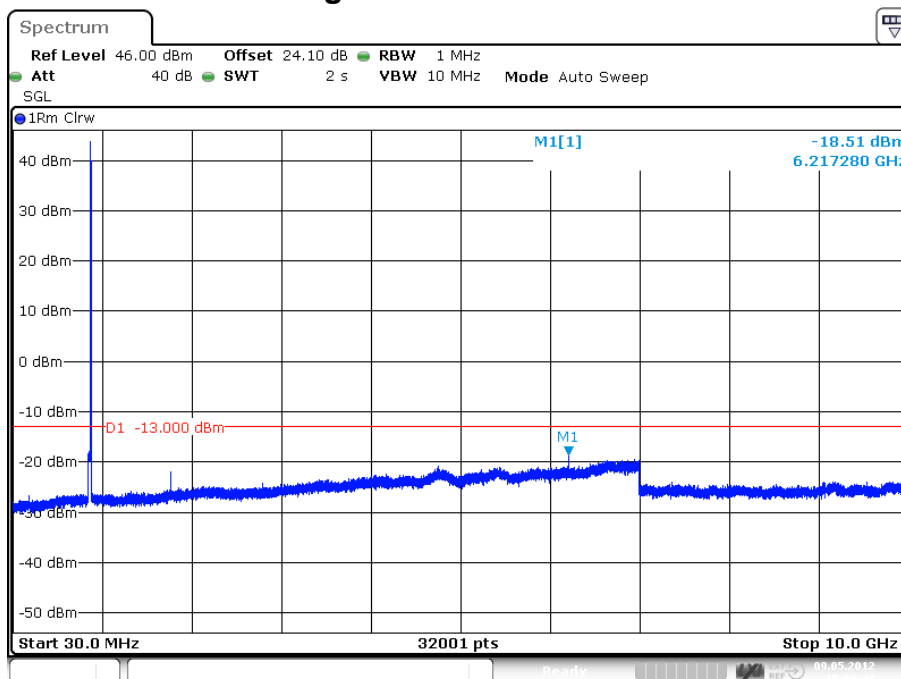

Date: 9.MAY.2012 15:59:42

plot 7.3.1.12-#1 Spurious Emissions at Antenna Terminals: §22.917, §2.1051; RSS-131, RSS-GEN; Test results; Downlink; LTE > 1MHz to band edge; carrier (881,5MHz) notched

Test Report No.: 12-089

FCC ID: XS5-M7785HP19P

IC ID: 2237E-M7785HP19P



7.3.2 Uplink

n.a.

Note: The EUT does not transmit over the air in the uplink direction.

7.4 Summary test result

Test result	complies, according the plots above
Tested by:	M. Leinfelder
Date:	09.05.2012

8 Amplifier Gain and Bandwidth: IC RSS-131

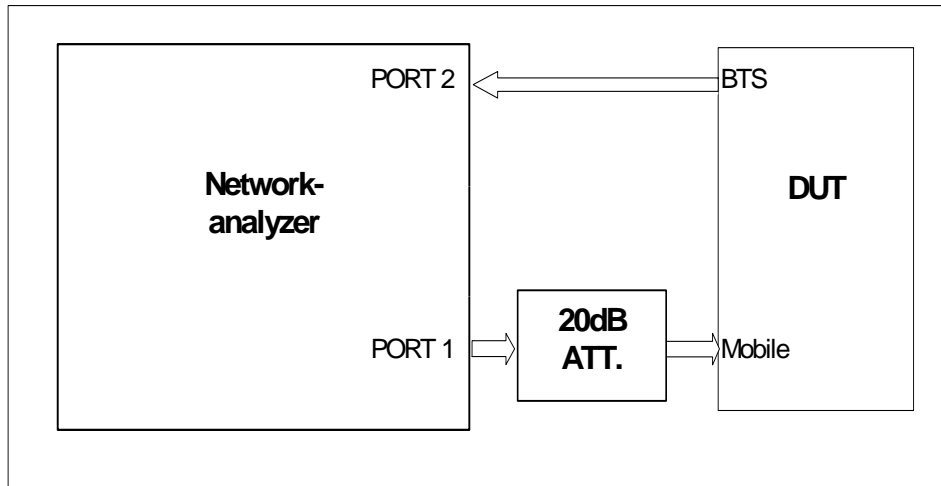

figure 8-#1 Test setup: Amplifier Gain and Bandwidth: IC RSS-131

Test equipment used	9102, 7336, 7409, 7449, 7443, 7444,
---------------------	-------------------------------------

8.1 Limit

IC RSS-131 clause 6.1

The passband gain shall not exceed the nominal gain by more than 1.0 dB. The 20 dB bandwidth shall not exceed the nominal bandwidth that is stated by the manufacturer. Outside of the 20 dB bandwidth, the gain shall not exceed the gain at the 20 dB point.

8.2 Test method

IC RSS-131 clause 4.2

Adjust the internal gain control of the equipment under test to the nominal gain for which equipment certification is sought.

With the aid of a signal generator and spectrum analyser, measure the 20 dB bandwidth of the amplifier (i.e. at the point where the gain has fallen by 20 dB). Measure the gain-versus-frequency response of the amplifier from the midband frequency f_0 of the pass band up to at least $f_0 \pm 250\%$ of the 20 dB bandwidth.

8.3 Test results

8.3.1 Downlink

Passband gain	36.7 dB
Lower limit of 20dB Bandwidth	863.6 MHz
Upper limit of 20dB Bandwidth	899.8 MHz
20dB Bandwidth	36.2 MHz

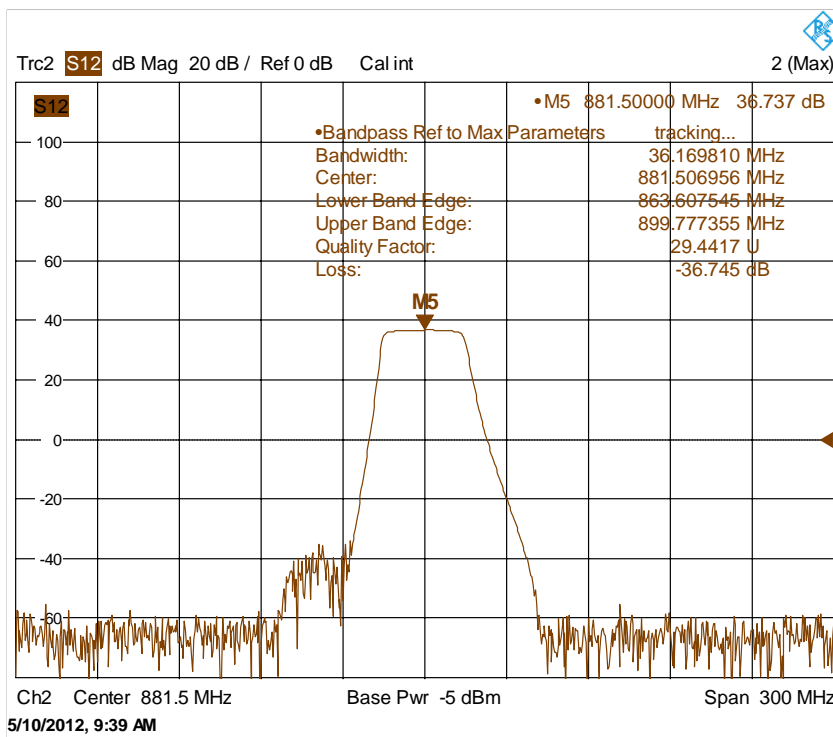

plot 8.3.1-#1 Amplifier Gain and Bandwidth: IC RSS-131; Test results; Downlink

8.3.2 Uplink

n.a.

Note: The EUT does not transmit over the air in the uplink direction.

8.4 Summary test result

Test result	complies, according the plots above
Tested by:	M. Leinfelder
Date:	10.05.2012



9 Output Power: IC RSS-131

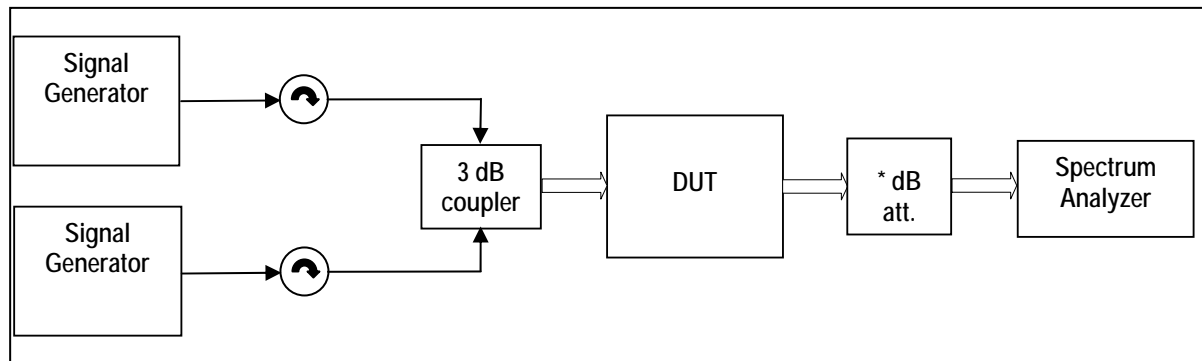

External Attenuator DL x dB = 20 dB
figure 9-#1 Test setup: Output Power: IC RSS-131

Measurement uncertainty	± 0,38 dB
Test equipment used	9054, 9101,8990, 7336, 7119, 7409, 7449, 7443, 7444,

9.1 Limit

IC RSS-131 clause 6.2

The manufacturer's output power rating P rated MUST NOT be greater than P mean for all types of enhancers.

9.2 Test method

IC RSS-131 clause 4.3.1 Multi-channel Enhancer

The following subscript "o" denotes a parameter at the enhancer output point.

Connect two signal generators to the input of the Device Under Test (DUT), via a proper impedance matching network (and preferably via a variable attenuator) so that the two input signals are equal sinusoids (and can be raised equally).

Connect a dummy load of suitable load rating to the enhancer output point. Connect also a spectrum analyser to this output point via a coupling network and attenuator, so that only a portion of the output signal is coupled to the spectrum analyser. The coupling attenuation shall be stated in the test report.

Set the two generator frequencies f_1 and f_2 such that they and their third-order intermodulation product frequencies, $f_3 = 2f_1 - f_2$ and $f_4 = 2f_2 - f_1$, are all within the pass band of the DUT.

Raise the input level to the DUT while observing the output tone levels, P_{o1} and P_{o2} , and the intermodulation product levels, P_{o3} and P_{o4} .

For enhancers rated 500 watts or less: Raise the input level to the DUT until the greater level of the intermodulation products at the enhancer output terminals, P_{o3} or P_{o4} , equals -43 dBW.

For enhancers rated over 500 watts: Raise the input level to the DUT until the greater level of the intermodulation products at the enhancer output terminals, P_{o3} or P_{o4} , is 67 dB below the level of either output tone level, P_{o1} or P_{o2} .

Record all signal levels and their frequencies. Calculate the mean output power (P_{mean}) under this testing condition using $P_{mean} = P_{o1} + 3$ dB.



9.3 Test results

9.3.1 Downlink

P_{o1} @ f_1	42.5 dBm @ 880.25 MHz
P_{o2} @ f_2	42.5 dBm @ 882.75 MHz
P_{o3} @ f_3	-14.03 dBm @ 877.75 MHz
P_{o4} @ f_4	-13.14 dBm @ 885.25 MHz

$$P_{\text{mean}} = P_{o1} + 3 \text{ dB}$$

$$P_{\text{mean}} = 42.5 \text{ dBm} + 3 \text{ dB} = 45.5 \text{ dBm}$$

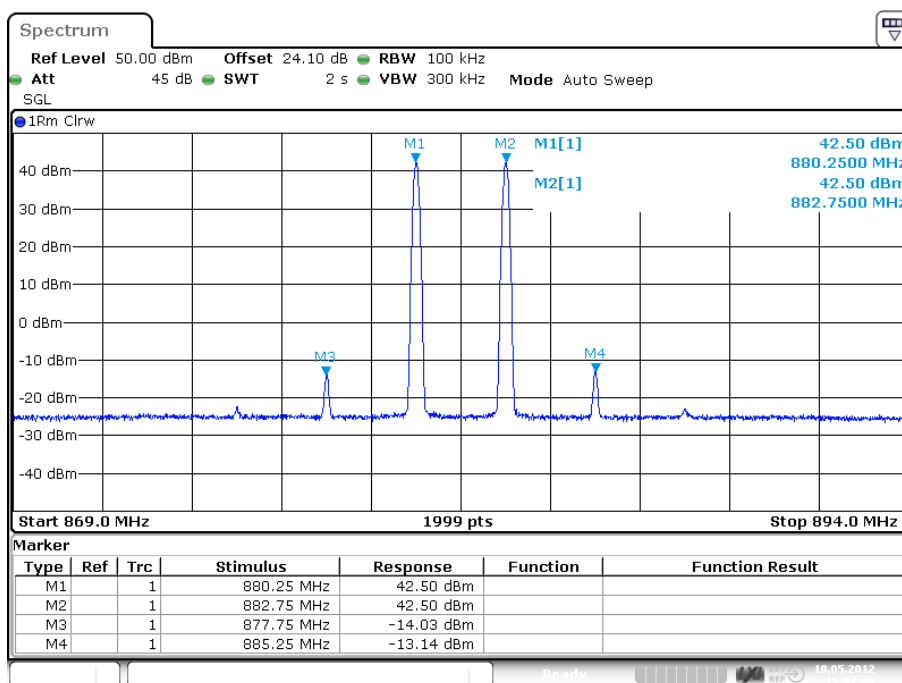

Date: 10. MAY. 2012 15:02:46

plot 9.3.1-#1 Output Power: IC RSS-131; Test results; Downlink

9.3.2 Uplink

n.a.

Note: The EUT does not transmit over the air in the uplink direction.

9.4 Summary test result

Test result	complies, according the plots above
Tested by:	M. Leinfelder
Date:	10.05.2012



10 Non-Linearity: IC RSS-131

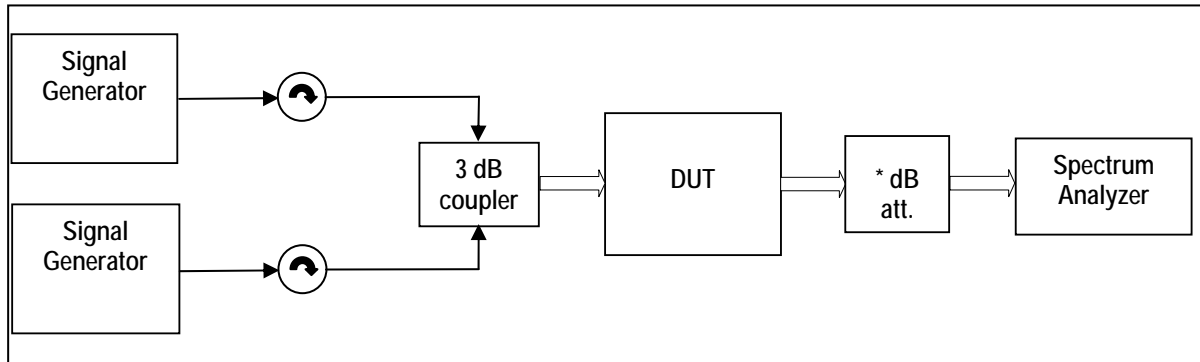

External Attenuator DL x dB = 20 dB
figure 10-#1 Test setup: Non-Linearity: IC RSS-131

Test equipment used	9054, 9101,8990, 7336, 7119, 7409, 7449, 7443, 7444,
---------------------	--

10.1 Limit

RSS-131 clause 6.3

Transmitter signals amplified by a non-linear device (enhancer or translator) will alter the occupied bandwidth of the transmitted signals; therefore, the extent of non-linearity shall be tested.

RSS-131 clause 6.3.1

For a multi-channel enhancer, any intermodulation product level must be attenuated, relative to P, by at least:

$$43 + 10 \log_{10} P, \text{ or } 70 \text{ dB, whichever is less stringent,}$$

where P is the total RF output power of the test tones in watts.

10.2 Test method

IC RSS-131 clause 4.3.1 Multi-channel Enhancer

The following subscript "o" denotes a parameter at the enhancer output point.

Connect two signal generators to the input of the Device Under Test (DUT), via a proper impedance matching network (and preferably via a variable attenuator) so that the two input signals are equal sinusoids (and can be raised equally).

Connect a dummy load of suitable load rating to the enhancer output point. Connect also a spectrum analyser to this output point via a coupling network and attenuator, so that only a portion of the output signal is coupled to the spectrum analyser. The coupling attenuation shall be stated in the test report.

Set the two generator frequencies f_1 and f_2 such that they and their third-order intermodulation product frequencies, $f_3 = 2f_1 - f_2$ and $f_4 = 2f_2 - f_1$, are all within the pass band of the DUT.

Raise the input level to the DUT while observing the output tone levels, P_{o1} and P_{o2} , and the intermodulation product levels, P_{o3} and P_{o4} .



10.3 Test results

10.3.1 Downlink

Requirement calculation:

$P = 42.5 \text{ dBm} = 17.78\text{W}$

Attenuation = $43 + 10\text{Log}_{10}(17.78\text{W})$ or 70 dB whichever is less stringent

Attenuation = 55.5 dB or 70 dB whichever is less stringent

Attenuation = 55.5 dB

Test result:

Delta P to IMD = $42.5 \text{ dBm} - (-13.14 \text{ dBm}) = 55.64 \text{ dB}$

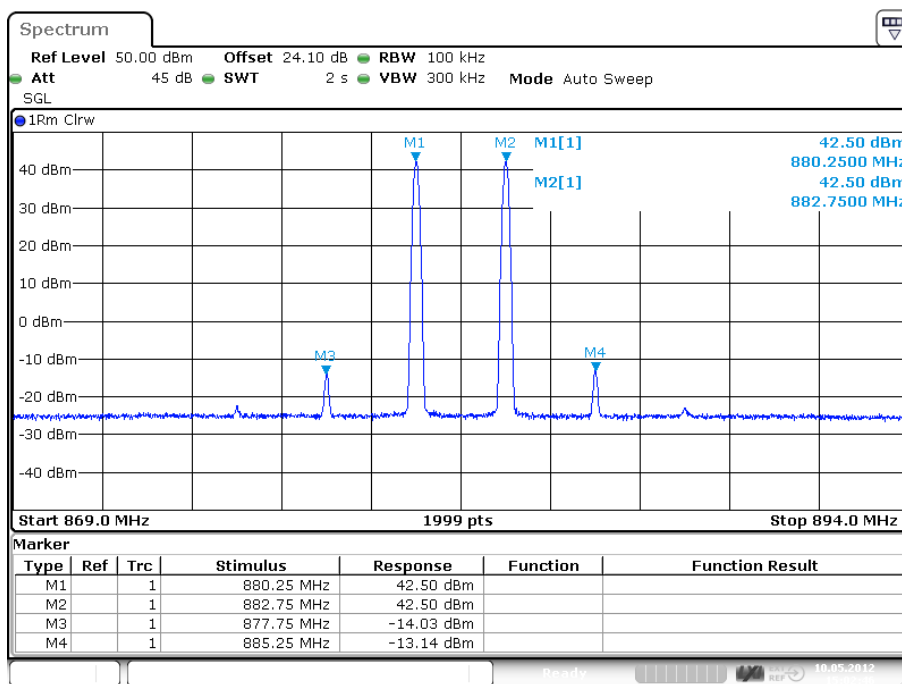

Date: 10. MAY. 2012 15:02:46

plot 10.3.1-#1 Non-Linearity: IC RSS-131; Test results; Downlink

10.3.2 Uplink

n.a.

Note: The EUT does not transmit over the air in the uplink direction.

10.4 Summary test result

Test result	complies, according the plots above
Tested by:	M. Leinfelder
Date:	10.05.2012



11 Spurious Emissions: RSS-131

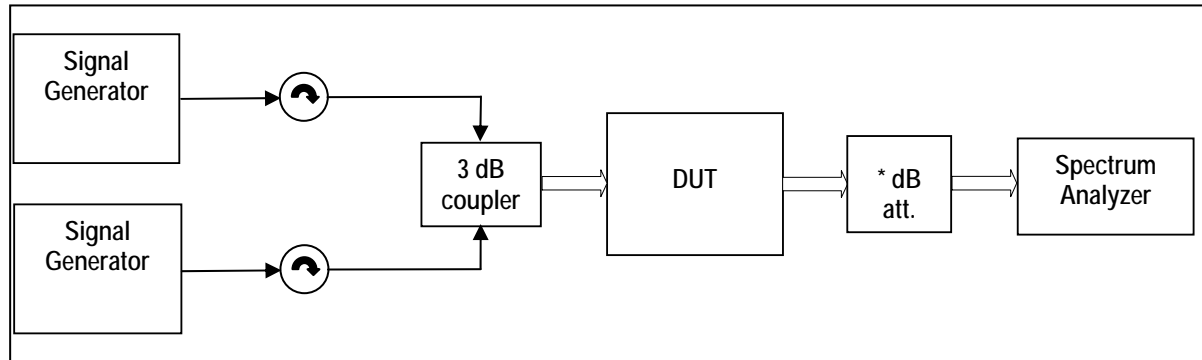

External Attenuator DL x dB = 20 dB
figure 11-#1 Test setup: Spurious Emissions: RSS-131

Measurement uncertainty	± 0,54 dB ± 1,2 dB ± 1,5 dB	9 kHz to 3 GHz 3 GHz to 7 GHz 7 GHz to 13,6 GHz
Test equipment used	9054, 9101,8990, 7336, 7119, 7409, 7449, 7443, 7444,	

11.1 Limit

RSS-131 clause 6.4

Spurious emissions of zone enhancers and translators shall be suppressed as much as possible.

Spurious emissions shall be attenuated below the rated power of the enhancer by at least:

$43 + 10 \log_{10}(P \text{ rated in watts})$, or 70 dB, whichever is less stringent.

11.2 Test method

RSS-131 clause 4.4.1

The spurious emissions of the equipment under test shall be measured using the two-tone method in section 4.3.1, with the two tones P_{01} and P_{02} set to the required levels.

Using a spectrum analyser with a resolution bandwidth set at 100 kHz, search for spurious emissions from 30 MHz to at least 5 times the highest RF pass band frequency. The search may omit the band that contains the test tones and intermodulation products.

11.3 Test results

11.3.1 Downlink

Requirement calculation:

$P = 42.5 \text{ dBm} = 17.78 \text{ W}$

Attenuation = $43 + 10 \log_{10}(17.78 \text{ W})$ or 70 dB whichever is less stringent

Attenuation = 55.5 dB or 70 dB whichever is less stringent

Attenuation = 55.5 dB

Test result:

Delta P to IMD = $42.5 \text{ dBm} - (-13.14 \text{ dBm}) = 55.64 \text{ dB}$

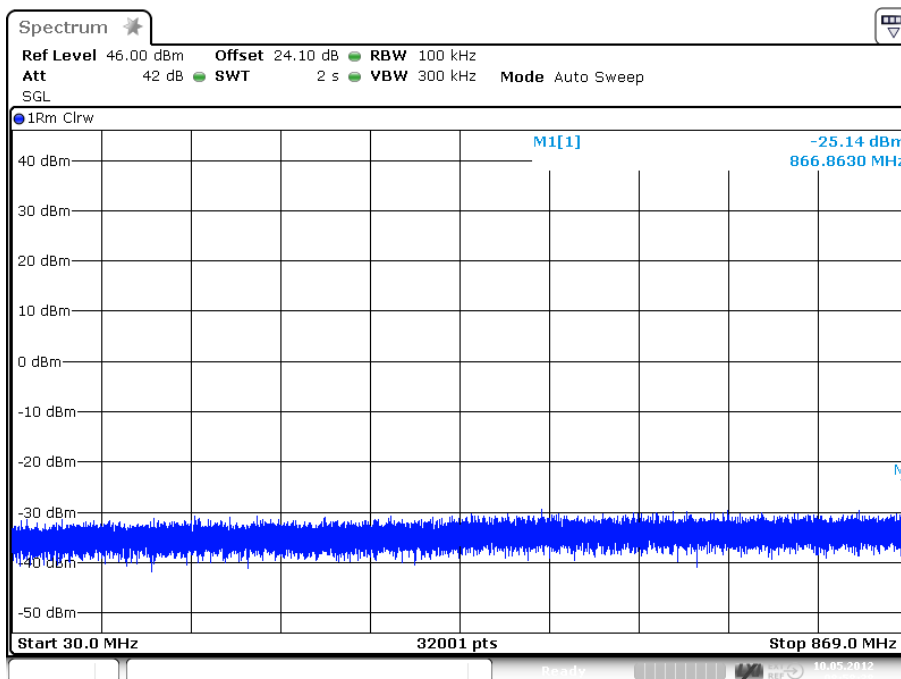

Date: 10.MAY.2012 08:58:39

plot 11.3.1-#1 Spurious Emissions: RSS-131; Test results; Downlink; 30 MHz – 869 MHz

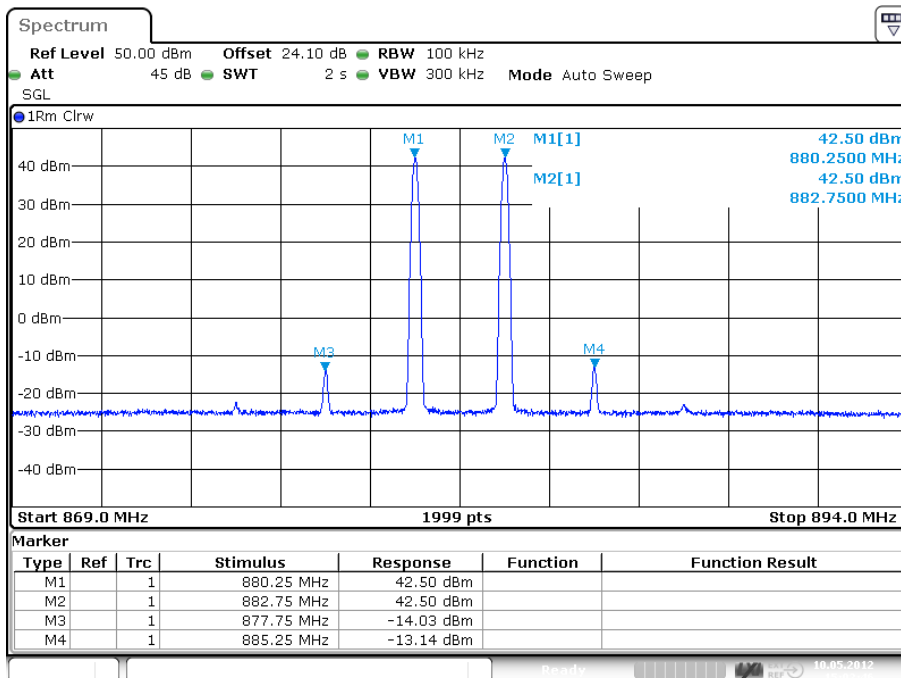

Date: 10.MAY.2012 15:02:46

plot 11.3.1-#2 Spurious Emissions: RSS-131; Test results; Downlink; 869 MHz – 894 MHz

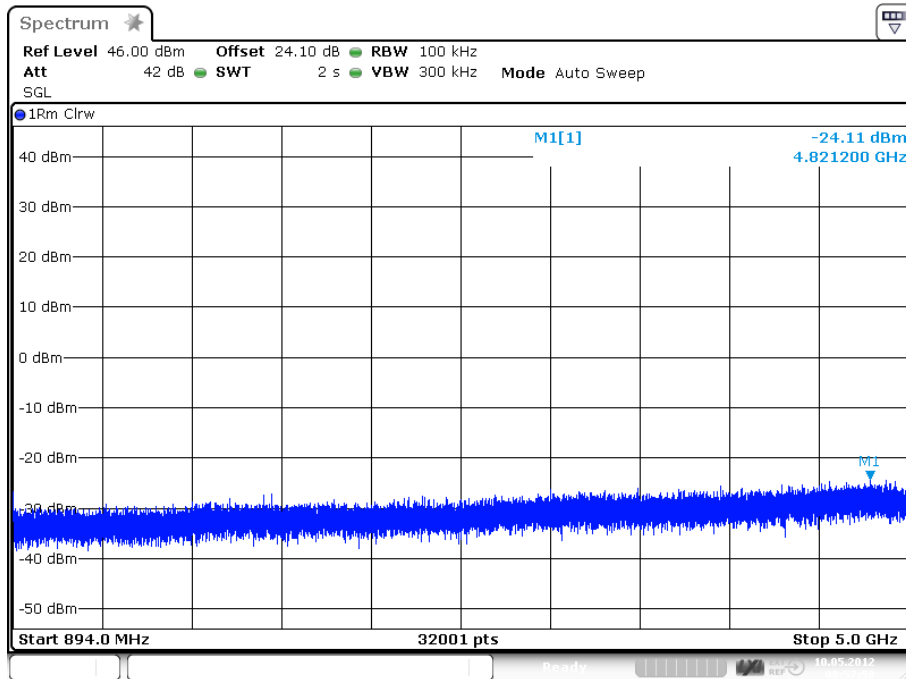

Date: 10.MAY.2012 08:57:58

plot 11.3.1-#3 Spurious Emissions: RSS-131; Test results; Downlink; 894 MHz – 5 GHz

11.3.2 Uplink

n.a.

Note: The EUT does not transmit over the air in the uplink direction.

11.4 Summary test result

Test result	complies, according the plots above
Tested by:	M. Leinfelder
Date:	10.05.2012

12 Field Strength of Spurious Emissions: §22.917, §2.1053



picture 8.1: label

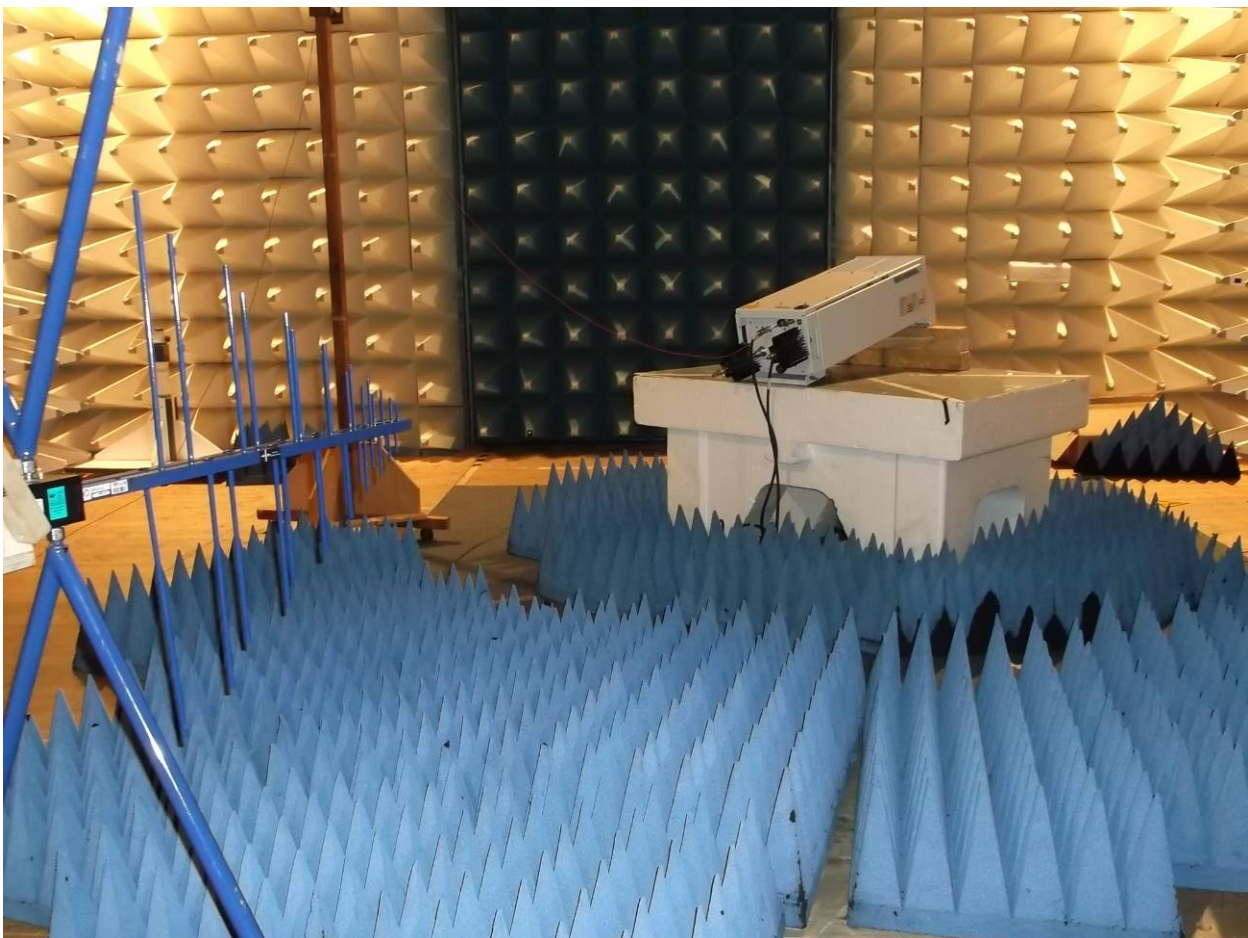

picture 8.2: Test setup: Field Strength Emission <1 GHz @3m in the FAC

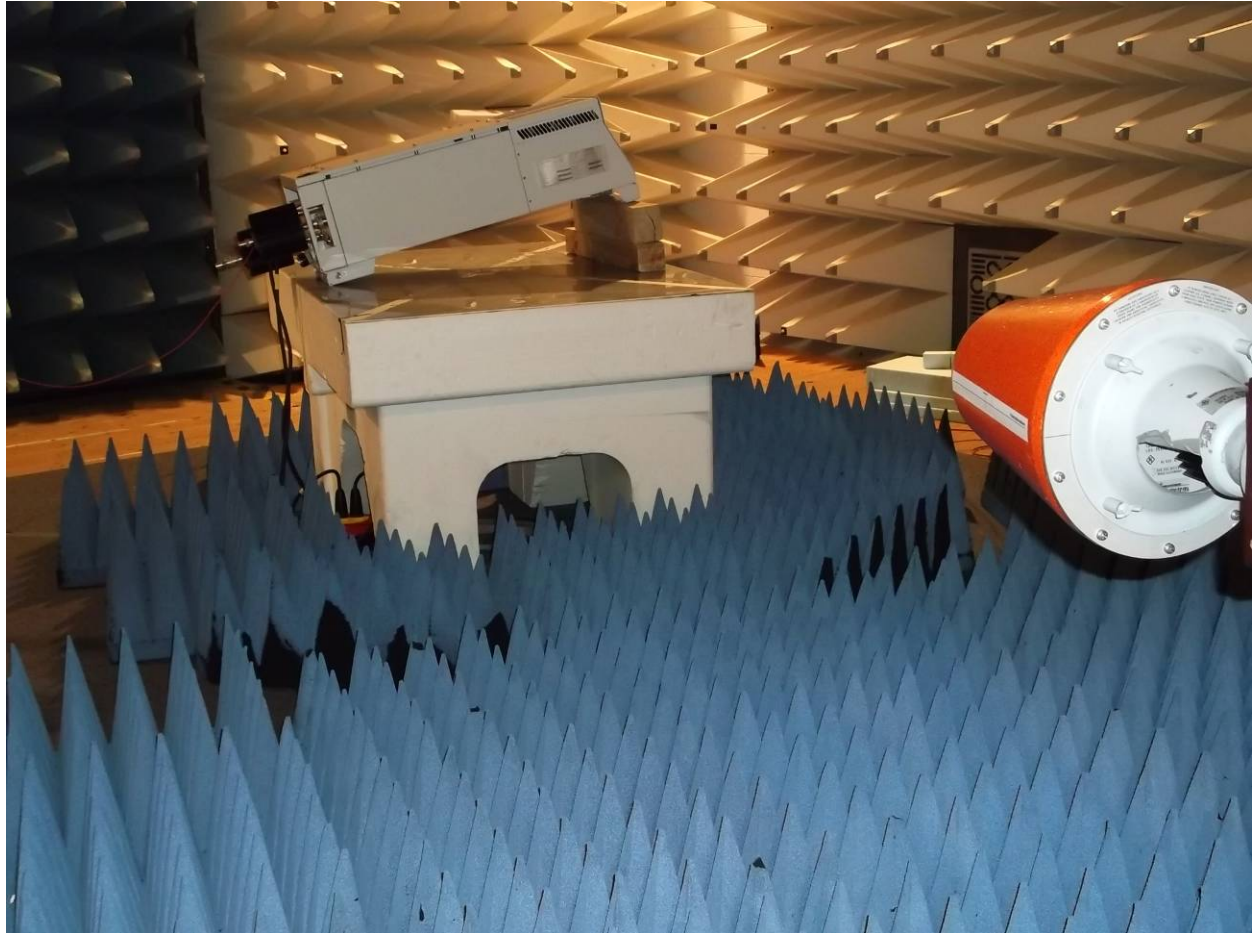

picture 8.3: Test setup: Field Strength Emission >1 GHz @3m in the FAC

Test Report No.: 12-089

FCC ID: XS5-M7785HP19P

IC ID: 2237E-M7785HP19P



This clause specifies requirements for the measurement of radiated emission.

Frequency range	Distance: EUT <-> antenna / location	Limit	Test method
30 MHz - 22 GHz	3 metres / FAC	FCC 47 CFR Part 22.917	TIA/EIA-603-C:2004
		IC RSS-131	
		FCC 47 CFR Part 22.917	
		IC RSS-131	

Test equipment used:

Designation	Type	Manufacturer	Invent.-no.	Cal.-date	due Cal.- date	used
EMI test receiver	ESI40	Rohde & Schwarz	E1687	22.12.2011	22.12.2012	X
Antenna	CBL 6111	Chase	K1149	02.08.2011	02.08.2012	X
RF Cable		Frankonia	K1121 SET	14.07.2011	14.07.2012	X
Antenna	HL 025	R&S	K809	25.07.2011	25.07.2012	X
Preamplifier	AFS4-00102000	Miteq	K817	13.10.2011	13.10.2012	X
RF Cable	Sucoflex 100	Suhner	K1742	05.04.2011	05.04.2012	X

The REMI version 2.135 has been used for max search.

Test set-up:

Test location: SAC/FAC
Both, the Fully Anechoic Chamber (FAC) and the Semi Anechoic Chamber (SAC) fulfil the requirements of ANSI C63.4 and CISPR 16-1-4 with regards to NSA and SVSWR.

Test Voltage: 115V / 60 Hz

Type of EUT: Wall mounted

Measurement uncertainty:

Measurement uncertainty expanded (95% or K=2)	± 4,7 dB for ANSI C63.4 measurement ± 0,5 dB for TIA-603 measurement
--	---

Test Report No.: 12-089

FCC ID: XS5-M7785HP19P

IC ID: 2237E-M7785HP19P



12.1 Limit §22.917

The rules in this section govern the spectral characteristics of emissions in the Broadband Personal Communications Service.

(a) *Out of band emissions.* The power of any emission outside of the authorized operating frequency ranges must be attenuated below the transmitting power (P) by a factor of at least $43 + 10 \log(P)$ dB.

(b) *Measurement procedure.* Compliance with these rules is based on the use of measurement instrumentation employing a resolution bandwidth of 1 MHz or greater. However, in the 1 MHz bands immediately outside and adjacent to the frequency block a resolution bandwidth of at least one percent of the emission bandwidth of the fundamental emission of the transmitter may be employed. A narrower resolution bandwidth is permitted in all cases to improve measurement accuracy provided the measured power is integrated over the full required measurement bandwidth (i.e. 1 MHz or 1 percent of emission bandwidth, as specified). The emission bandwidth is defined as the width of the signal between two points, one below the carrier center frequency and one above the carrier center frequency, outside of which all emissions are attenuated at least 26 dB below the transmitter power.

The emission measurements have been made with transmission at **Bottom/Middle/Top** frequency
(869MHz/881.5MHz/894MHz)

The limit is -13dBm (e.i.r.p).

12.2 Test method ANSI/TIA/EA-603-C

Measurement procedure. TIA-603-C

The antenna substitution method is used to determine the equivalent radiated power at spurious frequencies. The spurious emissions are measured at a distance of 3 meters. The EUT is then replaced with a reference substitution antenna with a known gain referenced to a dipole. This antenna is fed with a signal at the spurious frequency. The level of the signal is adjusted to repeat the previously measured level. The resulting eirp is the signal level fed to the reference antenna corrected for gain referenced to an isotropic dipole (see Figure 7.2).

From KDB (AMPLIFIER, BOOSTER, AND REPEATER REMINDER SHEET):

Radiated spurs (enclosure) – Use of CW signal (low, mid, and high freq.) is acceptable rather than all modulations.

The maximum RFI field strength was determined during the measurement by rotating the turntable (± 180 degrees) and varying the height of the receive antenna ($h = 1 \dots 4$ m) as like defined in ANSI C63.4. A measurement receiver has been used with a RBW 120 kHz up to 1 GHz and 1 MHz above 1 GHz. Steps with during pre measurement was half the RBW.

Both, the Fully Anechoic Chamber (FAC) and the Semi Anechoic Chamber (SAC) fulfil the requirements of ANSI C63.4 and CISPR 16-1-4 with regards to NSA and SVSWR.

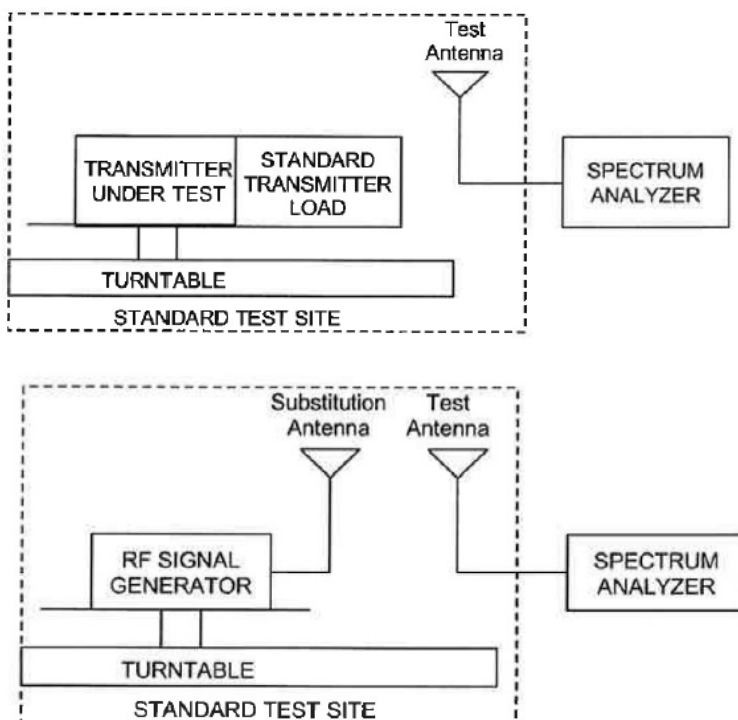

picture 8.3: Substitution method

12.3 Climatic values in the lab

Temperature: 22°
 Relative Humidity: 43%
 Air-pressure: 1009hPa

Test Report No.: 12-089

FCC ID: XS5-M7785HP19P

IC ID: 2237E-M7785HP19P



12.4 Test results

12.4.1 30 MHz to 1 GHz Downlink (Bottom – Middle – Top)

B/M/T: 869MHz/881.5MHz/894MHz

Polarisation: horizontal, vertical

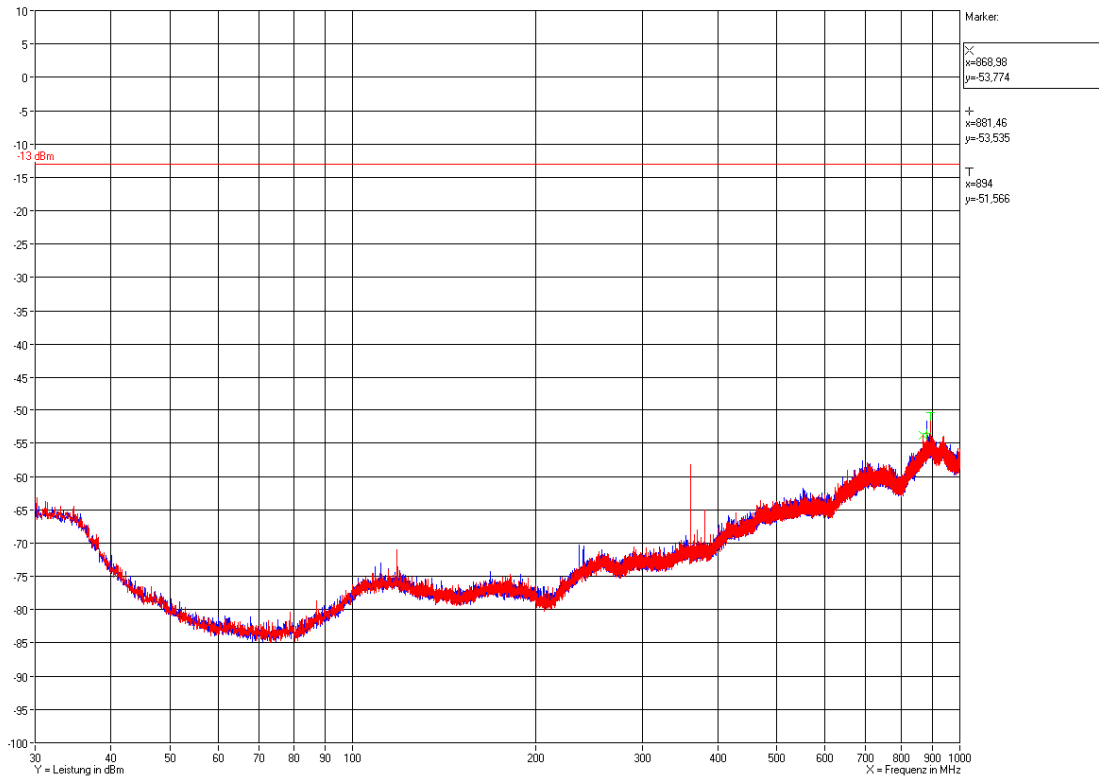

Plot 12.1: Measurement: Field Strength Emission <1 GHz @3m in the FAC max.hold



12.4.2 1 GHz to 22 GHz Downlink (middle of all paths)

F1: 751.5 MHz; F2: 737 MHz; F3: 881.5 MHz; F4: 1962.5 MHz

Polarisation: horizontal, vertical

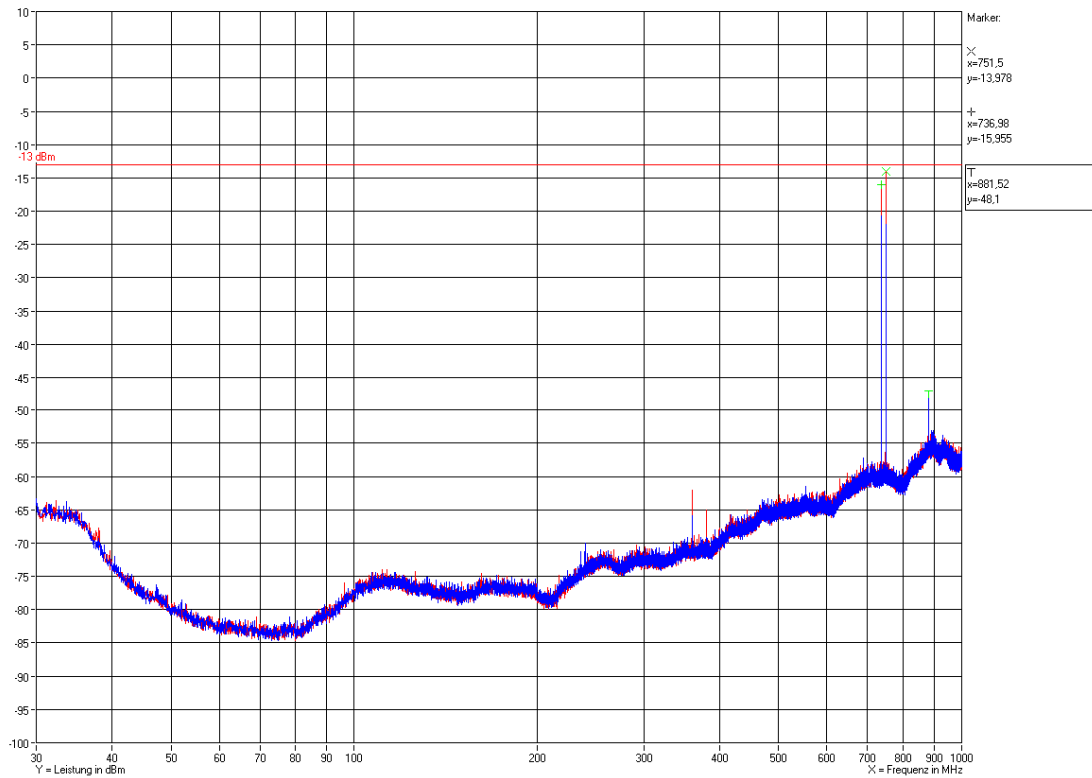

Plot 12.2: Measurement: Field Strength Emission <1 GHz @3m in the FAC max.hold

Test Report No.: 12-089

FCC ID: XS5-M7785HP19P

IC ID: 2237E-M7785HP19P



12.4.3 1 GHz to 22 GHz Downlink (Bottom – Middle – Top)

B/M/T: 869MHz/881.5MHz/894MHz

Polarisation: horizontal, vertical

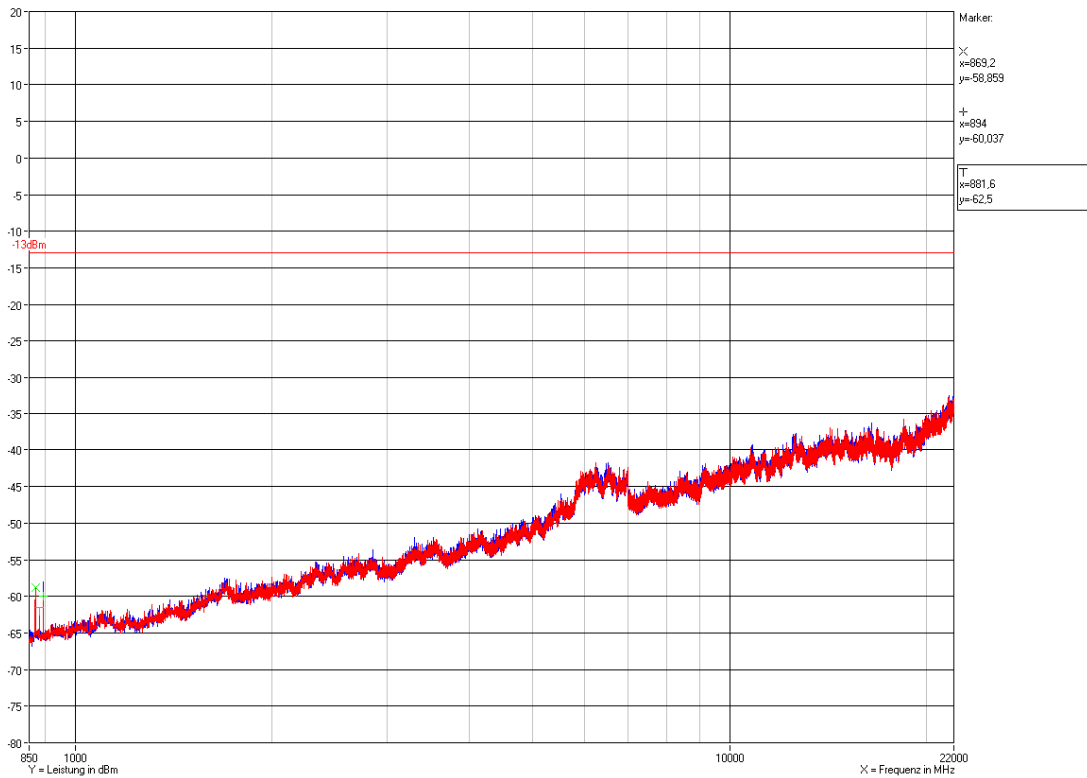

Plot 12.3: Measurement: Field Strength Emission >1 GHz to 22GHz @3m in the FAC max.hold



12.4.4 1 GHz to 22 GHz Downlink (middle of all paths)

F1: 751.5 MHz; F2: 737 MHz; F3: 881.5 MHz; F4: 1962.5 MHz

Polarisation: horizontal, vertical

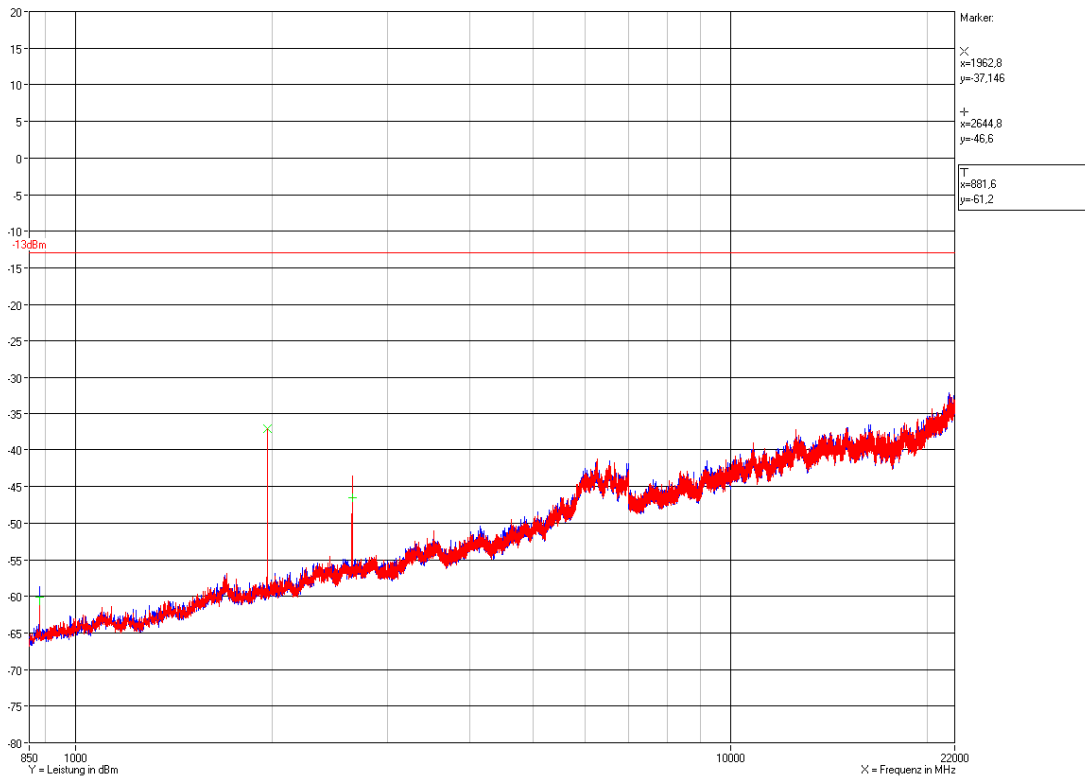

Plot 12.4: Measurement: Field Strength Emission >1 GHz to 22GHz @3m in the FAC max.hold

12.5 Summary test result

Test result	complies, according to the plots above
Tested by:	Tom Zahlmann
Date:	09.05.2012

13 History

Revision	Modification	Date	Name
V01.00	Initial	11.05.2012	Tom Zahlmann

Test Report No.: 12-089

FCC ID: XS5-M7785HP19P

IC ID: 2237E-M7785HP19P



******* End of test report *******