

Test Site:  
FCC Test Site No.: 96997  
IC OATS No.: IC3475A-1



## ECL-EMC Test Report No.: 12-147

**Equipment under test:** ION-M7P/17P/19P 1700MHz Path  
**FCC ID:** XS5-M71719P  
**IC ID:** 2237E-M71719P  
**Type of test:** **FCC 47 CFR Part 27 Subpart C: 2012**  
Miscellaneous Wireless Communication Services  
**IC RSS-139:2009**  
Advanced Wireless Services Equipment Operating in  
the Bands 1710-1755 MHz and 2110-2155 MHz

**Measurement Procedures:** 47 CFR Parts 2 (*Frequency Allocations and Radio Treaty Matters; General Rules and Regulations*),  
Part 27:2012 (*Miscellaneous Wireless Communication Services*),  
ANSI/TIA-603-C (2004), *Land Mobile FM or PM Communications Equipment Measurement and Performance Standards*  
IC-GEN General Requirements and Information for the  
Certification of Radiocommunication Equipment

**Test result:** **Passed**

Date of issue:	09.08.12		Signature:
Issue-No.:	01	Author:	
Date of delivery:	06.08.12	Checked:	
Test dates:	1.04.11 – 06.08.12		
Pages:	42		

Test Report No.: 12-147

FCC ID: XS5-M71719P

IC ID: 2237E-M71719P

---



**Manufacturer:** ANDREW Wireless Systems GmbH  
Industriering 10

D-86675 Buchdorf

Tel.: +49 (0)9099 69 0

Fax: +49 (0)9099 69 140

**Test Location:** TEMPTON Service Plus GmbH  
European Compliance Laboratory (ECL)

Thurn-und-Taxis-Straße 18

D-90411 Nürnberg

Tel.: +49 (0) 911 59835 0

Fax: +49 (0) 911 59835 90

**General:**

The purpose of this report is to show compliance to the FCC regulations for devices operating under Part N 22,N°27 of the Code of Federal Regulations title 47.

This report informs about the results of the EMC tests, it only refers to the equipment under test. No part of this report may be reproduced in any form, without written permission.



## Table of contents

1	TEST RESULTS SUMMARY .....	5
2	EQUIPMENT UNDER TEST (E.U.T.) .....	6
2.1	DESCRIPTION .....	6
2.1.1	DOWNLINK .....	6
2.1.2	UPLINK .....	6
2.1.3	DESCRIPTION OF EUT .....	6
2.1.4	BLOCK DIAGRAM OF MEASUREMENT REFERENCE POINTS .....	7
2.1.5	DOWNLINK SYSTEM GAIN AND OUTPUT POWER .....	7
3	TEST SITE (ANDREW BUCHDORF) .....	8
3.1	TEST ENVIRONMENT .....	8
3.2	TEST EQUIPMENT .....	8
3.3	INPUT AND OUTPUT LOSSES .....	9
3.4	MEASUREMENT UNCERTAINTY .....	9
4	TEST SITE (TEMPTON) .....	10
5	RF POWER OUT: §27.50, §2.1046 .....	11
5.1	LIMIT .....	11
5.2	TEST METHOD .....	11
5.3	TEST RESULTS .....	12
5.3.1	DOWNLINK .....	12
5.3.1.1	CDMA .....	13
5.3.1.2	W-CDMA .....	13
5.3.1.3	LTE .....	14
5.3.2	UPLINK .....	14
5.4	SUMMARY TEST RESULT .....	14
6	OCCUPIED BANDWIDTH: §2.1049 .....	15
6.1	LIMIT .....	15
6.2	TEST METHOD .....	15
6.3	TEST RESULTS .....	15
6.3.1	DOWNLINK .....	15
6.3.1.1	CDMA .....	16
6.3.1.2	W-CDMA .....	17
6.3.1.3	LTE .....	18
6.3.2	UPLINK .....	19
6.4	SUMMARY TEST RESULT .....	19
7	SPURIOUS EMISSIONS AT ANTENNA TERMINALS: §27.53, §2.1051 .....	20
7.1	LIMIT .....	20
7.2	TEST METHOD .....	20
7.3	TEST RESULTS .....	21
7.3.1	DOWNLINK .....	21
7.3.1.1	WCDMA < 1MHz to band edge .....	22



7.3.1.2	CDMA < 1MHz to band edge.....	23
7.3.1.3	LTE < 1MHz to band edge.....	24
7.3.1.4	CDMA > 1MHz to band edge.....	25
7.3.1.5	W-CDMA > 1MHz to band edge.....	25
7.3.1.6	LTE > 1MHz to band edge.....	26
7.3.2	UPLINK.....	26
7.4	SUMMARY TEST RESULT.....	26
8	TRANSMITTER OUTPUT POWER: IC RSS-139, RSS-GEN.....	27
8.1	LIMIT.....	27
8.2	TEST METHOD.....	27
8.3	TEST RESULTS.....	27
8.3.1	DOWNLINK.....	28
8.3.1.1	CDMA.....	29
8.3.1.2	WCDMA.....	29
8.3.1.3	LTE.....	30
8.3.2	UPLINK.....	30
8.4	SUMMARY TEST RESULT.....	30
9	TRANSMITTER UNWANTED EMISSIONS: IC RSS-139.....	31
9.1	LIMIT.....	31
9.2	TEST METHOD.....	31
9.3	TEST RESULTS.....	31
10	RECEIVER SPURIOUS EMISSIONS: IC RSS-139A.....	32
10.1	LIMIT.....	32
11	FIELD STRENGTH OF SPURIOUS EMISSIONS: §27.53, §2.1053, RSS-139.....	33
11.1	METHOD OF MEASUREMENT.....	36
11.2	LIMIT §27.53 (H).....	37
11.3	RECEIVER SETTINGS.....	37
11.4	CLIMATIC VALUES IN THE LAB.....	37
11.5	TEST RESULTS.....	38
11.5.1	30 MHz TO 1 GHz DOWNLINK (BOTTOM – MIDDLE – TOP).....	38
11.5.2	30 MHz TO 1 GHz DOWNLINK (MIDDLE OF ALL BANDS).....	39
11.5.3	1 GHz TO 22 GHz DOWNLINK (BOTTOM – MIDDLE – TOP).....	40
11.5.4	1 GHz TO 22 GHz DOWNLINK (MIDDLE OF ALL BANDS).....	41
12	HISTORY.....	41



## 1 Test Results Summary

Name of Test	FCC Para. No.	FCC Method	FCC Spec.	Result
RF Power Output	27.50(d)	2.1046	1640 Watts/MHz	Complies
Occupied Bandwidth	2.1049	2.1049	Input/Output	Complies
Spurious Emissions at Antenna Terminals	27.53(h)	2.1051	-13dBm	Complies
Field Strength of Spurious Emissions	27.53(m)	2.1053 TIA/EA-603	-13dBm E.I.R.P	Complies
Frequency Stability	27.54	2.1055	Must stay in band	NA

Name of Test	IC Para. No.	IC Method	Result
RF Power Output	RSS-139 6.4	RSS-GEN 4.8	Complies
Occupied Bandwidth	RSS-Gen 4.6	RSS-GEN 4.6.1	Complies
Spurious Emissions at Antenna Terminals	RSS-139 6.5	RSS-GEN 4.9	Complies
Field Strength of Spurious Emissions	RSS-139 6.5	RSS-GEN 4.9 SRSP-513	Complies
Frequency Stability	RSS-139 6.3	RSS-GEN 4.7	NA

Frequency stability is not applicable because the device uses a common oscillator to up convert and down convert the RF signal. The EUT does not contain modulation circuitry, or frequency generation, therefore the test was not performed.



## 2 Equipment under test (E.U.T.)

### 2.1 Description

Kind of equipment	ION-M7P/17P/19P	
Andrew Ident. Number	Id.No. 7629728-0007	
Serial no.(SN)	46	
Revision	00	
Software version and ID	n. a.	
Type of modulation and Designator	CDMA (F9W)	<input checked="" type="checkbox"/>
	W-CDMA (F9W)	<input checked="" type="checkbox"/>
	LTE (G7D)	<input checked="" type="checkbox"/>
Frequency Translation	F1-F1	<input checked="" type="checkbox"/>
	F1-F2	<input type="checkbox"/>
	N/A	<input type="checkbox"/>
Band Selection	Software	<input type="checkbox"/>
	Duplexer	<input checked="" type="checkbox"/>
	Full band	<input type="checkbox"/>

#### 2.1.1 Downlink

Pass band	2110 MHz – 2155 MHz
Max. composite output power based on one carrier per path (rated)	43,14 dBm = 20,61W
Gain	10 dB @ Pout BTS of 33 dBm

#### 2.1.2 Uplink

Pass band	1710 MHz – 1755 MHz
Gain	n.a.

Note: The EUT does not transmit over the air in the uplink direction.

#### 2.1.3 Description of EUT

ION-M7P/17P/19P is a multi-band, multi-operator remote unit configuration used in conjunction with a master unit in the ION optical distribution system.

This system transports up to three frequency bands simultaneously (700 MHz, 1700/2100 MHz, 1900 MHz), providing a cost-effective solution for distributing capacity from one or more base stations.

The ION- M7P/17P/19P Repeater consists of one 700 MHz path, one 1700/2100 MHz path and one 1900 MHz, with the intended use of simultaneous transmission

This Test Report describes only the approval of the 1700/2100 MHz path



### 2.1.4 Block diagram of measurement reference points

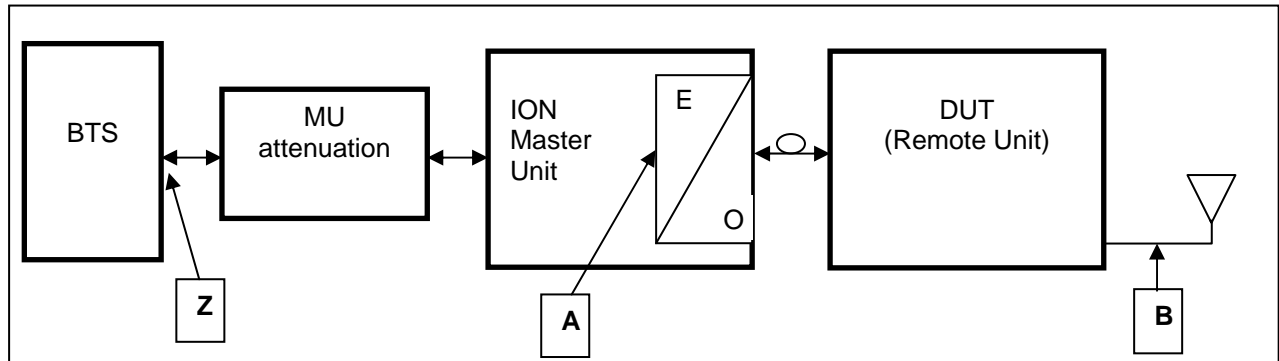

figure 2.1.4-#1 Block diagram of measurement reference points

Remote Unit is the EUT

O/E                      Optical / Electrical converter  
 SRMU                    Sub Rack Master Unit

Reference point A	SRMU	UL output,	DL input
Reference point B	Remote Unit	DL output,	UL input
Reference point Z	BTS	DL output,	UL input

Downlink:                      Measure from reference point A to B

Since a signal generator does not supply a good output signal with +33 or +43dBm, for the downlink measurement the MU Attenuation is not used.

That means for downlink measurements the signal generator is connected to measurement point A at the master optical / electrical converter and the analyzer to the measurement point B at the RU.

### 2.1.5 Downlink System Gain and Output Power

System optimized for BTS power (fixed value)	MU Attenuation (manual leveling)	Maximum rated input power at the MU OTRX (fixed value)	RU Gain (fixed value)	Maximum rated output power at RU Antenna port (fixed value)
Z		A	A to B	B
+33 dBm	30 dB	3 dBm	+40 dB	+43 dBm @ 1 carrier
<b>System Gain Z to A</b>	<b>+10 dB</b>			
+43 dBm	40 dB	3 dBm	+40 dB	+43 dBm @ 1 carrier
<b>System Gain Z to A</b>	<b>0 dB</b>			

table 2.1.5-#1 Equipment under test (E.U.T.) Description Downlink System Gain and Output Power



### 3 Test site (Andrew Buchdorf)

#### 3.1 Test environment

All tests were performed under the following environmental conditions:

Condition	Minimum value	Maximum value
Barometric pressure	86 kPa	106 kPa
Temperature	15°C	30°C
Relative Humidity	20 %	75 %
Power supply range	±5% of rated voltages	

#### 3.2 Test equipment

ANDREW Inv. No.	Test equipment	Type	Manufacturer	Serial No.	Calibration
8372	Network Analyzer	8753D	HP	3410A08675	02/13
8961	Spectrum Analyzer	FSP-13	R&S	100147/013	07/13
8798	Spectrum Analyzer	FSQ-26	R&S	100340	03/13
8849	Signal Generator	SMU200A	R&S	101732	02/13
8956	Signal Generator	SMIQ 03B	R&S	100435	12/13
7192	Power Attenuator	769-30	Narda	07448	CIU
7191	Power Attenuator	765-20	Narda	0012	CIU
7338	Power Attenuator	769-10	Narda	05773	CIU
7119	Divider	2way	Mikom	3512	CIU
7287	RF-Cable	2,0m; N-N	Huber & Suhner	28441/4PEA	CIU
7288	RF-Cable	2,0m; N-N	Huber & Suhner	28442/4PEA	CIU
7391	RF-Cable	1,0m; SMA	Huber & Suhner	40447/4P	CIU

CIU = Calibrate in use





ANDREW Inv. No.	Test equipment	Type	Manufacturer	Serial No.	Calibration
8741	Network Analyzer	ZVRE	R&S	100034	02/2013
9126	Spectrum Analyzer	FSV	R&S		11/2012
9123	Generator	SMBV100A	R&S		11/2012
9069	Generator	SMBV100A	R&S		08/2013
8667	Power Meter	E4418A	Agilent	GB38273230	04/2013
8668	Power Sensor	E8481H	Agilent	US3318A19208	04/2013
7157	RF-Cable	Succoflex	Suhner	36180/4P	CIU
7158	RF-Cable	Succoflex	Suhner	36182/4P	CIU
7289	RF-Cable	Succoflex	Suhner	28443/4PE	CIU
7290	RF-Cable	Succoflex	Suhner	28444/4PE	CIU
7385	RF-Cable	Succoflex	Suhner	36267/4P	CIU
7387	RF-Cable	Succoflex	Suhner	36267/4P	CIU
7390	RF-Cable	Succoflex	Suhner	40193/4P	CIU
7381	RF-Cable	Succoflex	Suhner	40200/4P	CIU
7384	RF-Cable	Succoflex	Suhner	40448/4P	CIU
7294	RF-Cable	Succoflex	Suhner	40448/4P	CIU
7382	RF-Cable	Succoflex	Suhner	40221/4P	CIU
7406	Matrix		Andrew		CIU

CIU = Calibrate in use

### 3.3 Input and output losses

All recorded power levels should be referenced to the input and output connectors of the repeater, unless explicitly stated otherwise.

The test equipment used in this test has to be calibrated, so that the functionality is also checked.

All cables, attenuators, splitter, isolator, circulator and combiner etc. must be measured before testing and used for compensation during testing.

### 3.4 Measurement uncertainty

The extended measurement uncertainty corresponds to the measurement results from the standard measurement uncertainty multiplied by the coverage factor  $k=2$ . The true value is located in the corresponding interval with a probability of 95 %.

Test Report No.: 12-147

FCC ID: XS5-M71719P

IC ID: 2237E-M71719P

---



#### 4 Test site (TEMPTON)

FCC Test site: 96997  
IC OATS: IC3475A-1

See relevant dates under section 12 of this test report.



## 5 RF Power Out: §27.50, §2.1046

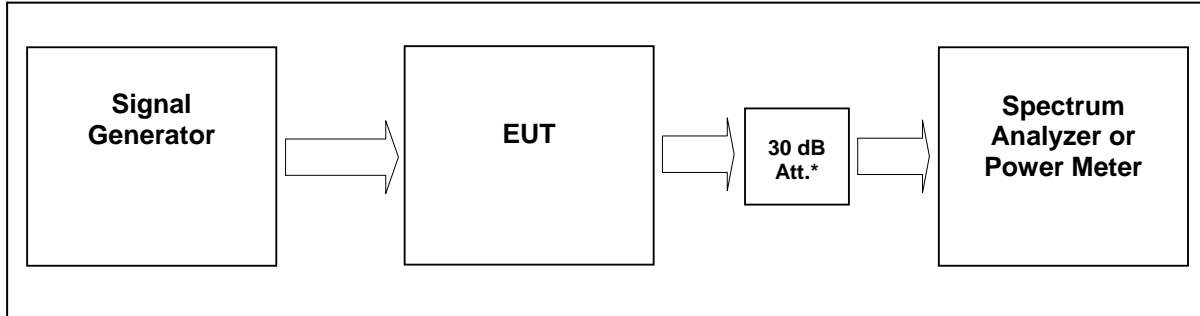

figure 3.4-#1 Test setup: RF Power Out: §27.50, §2.1046

Measurement uncertainty	± 0,38 dB
Test equipment used	8890; 8667; 8668; 8848; 7355;

### 5.1 Limit

Minimum standard:

Para. No.27.50(d)(2)(B)

(d) The following power and antenna height requirements apply to stations transmitting in the 1710–1755 MHz and 2110–2155 MHz bands:

(2) The power of each fixed or base station transmitting in the 2110–2155 MHz band and situated in any geographic location other than that described in paragraph (d)(1) is limited to:

(B) an EIRP of 1640 watts/MHz when transmitting with an emission bandwidth greater than 1 MHz.

### 5.2 Test method

§ 2.1046 Measurements required: RF power output.

(a) For transmitters other than single sideband, independent sideband and controlled carrier radiotelephone, power output shall be measured at the RF output terminals when the transmitter is adjusted in accordance with the tune-up procedure to give the values of current and voltage on the circuit elements specified in § 2.1033(c)(8). The electrical characteristics of the radio frequency load attached to the output terminals when this test is made shall be stated.

(c) For measurements conducted pursuant to paragraphs (a) and (b) of this section, all calculations and methods used by the applicant for determining carrier power or peak envelope power, as appropriate, on the basis of measured power in the radio frequency load attached to the transmitter output terminals shall be shown. Under the test conditions specified, no components of the emission spectrum shall exceed the limits specified in the applicable rule parts as necessary for meeting occupied bandwidth or emission limitations



### 5.3 Test results

Detector RMS.

#### Test signal CDMA

Signal waveform according to table 6.2-1 of standard specification 3GPP2 C.p0051-0 v1.0 16.February 2006 pilot, sync, paging, 37 traffics, which is equal to the table 6.5.2.1 of 3GPP2 C.S0010-C v2.0 24.February 2006.

#### Test signal WCDMA

Signal waveform according to Test Model 1 of standard specification 3GPP TS25.141. Signal modulated with a combination of PCCPCH, SCCPCH and Dedicated Physical Channels specified as test model 1 64 DPCH.

#### Test signal LTE:

Signal waveform according to Test Model 1.1, E-TM1.1, clause 6.1.1.1-1, table 6.1.1.1-1 of standard specification 3GPP TS 36.141 V9.3.0 (2010-03).

#### 5.3.1 Downlink

Modulation	Measured at	RBW VBW Span	RF Power (dBm)	RF Power (W)	Plot -
CDMA	2132,5 MHz	3MHz 10MHz 15MHz	43,14	20,61	5.3.1.1 #1
WCDMA	2132,5 MHz	10MHz 10MHz 50MHz	43,01	20,00	5.3.1.2 #1
LTE	2132,5 MHz	3MHz 10MHz 50MHz	43,04	20,14	5.3.1.3 #1
Maximum output power = 43,14 dBm -> 20,61W					
Limit Maximum output power = 1640 W (EIRP)					

table 5.3.1-#1 RF Power Out: §27.50, §2.1046 Test results Downlink

The max RF Power out is 43.1 dBm, so the maximum antenna gain (x) can be calculated as follow:

**Limit = 1000W (erp) = 60 dBm**

Info: 1000W (erp) = 1640W (eirp)

60 dBm > 43.1 dBm + x

**16.9 dBd = 19.05 dBi > x**

=> The antenna that will use for the complete system have to have a gain lower than 19 dBi, relative to a dipol.

Modulation	Pin / dBm (Ref. point A)
CDMA	2,9
WCDMA	3,0
LTE	3,0

table 5.3.1-#2 RF Power Out: §27.50, §2.1046 Test results Downlink Input power



### 5.3.1.1 CDMA

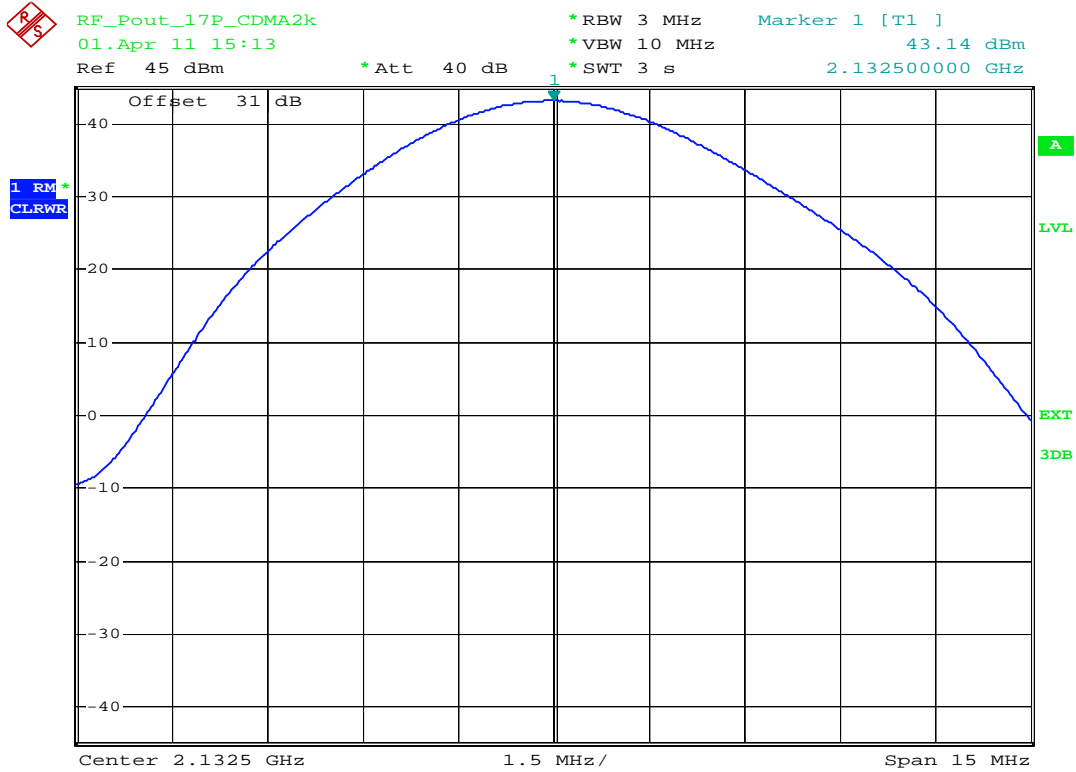

plot 5.3.1.1-#1 RF Power Out: §27.50, §2.1046; Test results; Downlink; CDMA Middle

### 5.3.1.2 W-CDMA

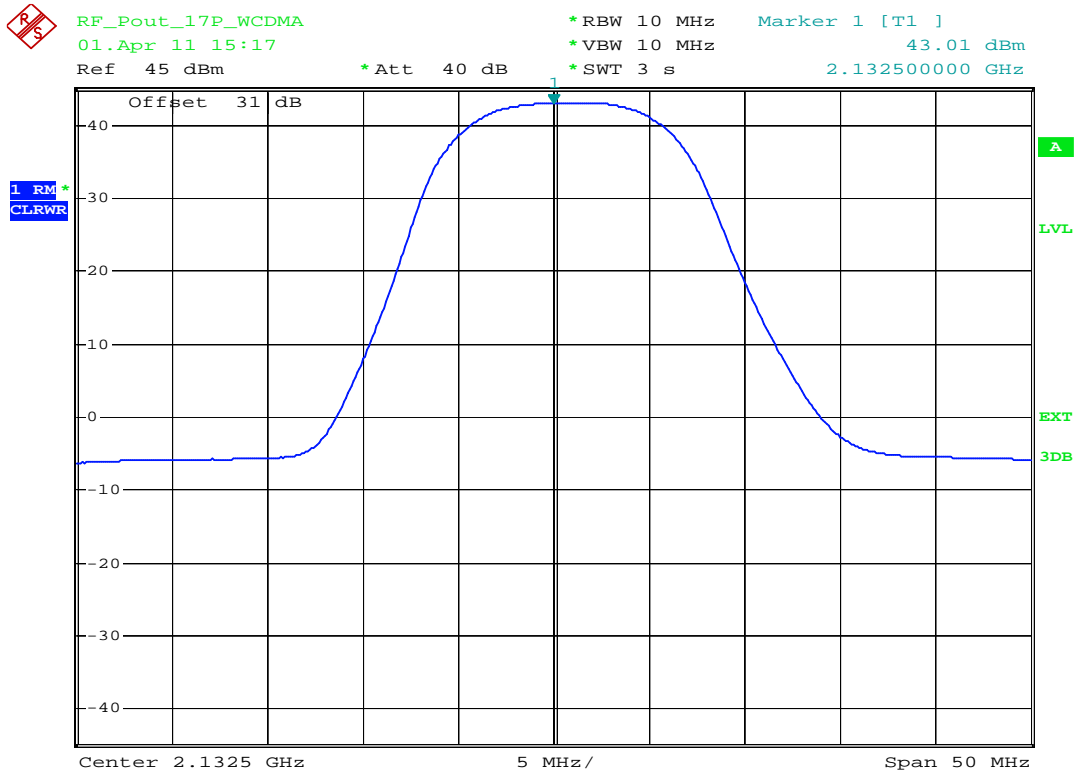

plot 5.3.1.2-#1 RF Power Out: §27.50, §2.1046; Test results; Downlink; W-CDMA Middle



### 5.3.1.3 LTE

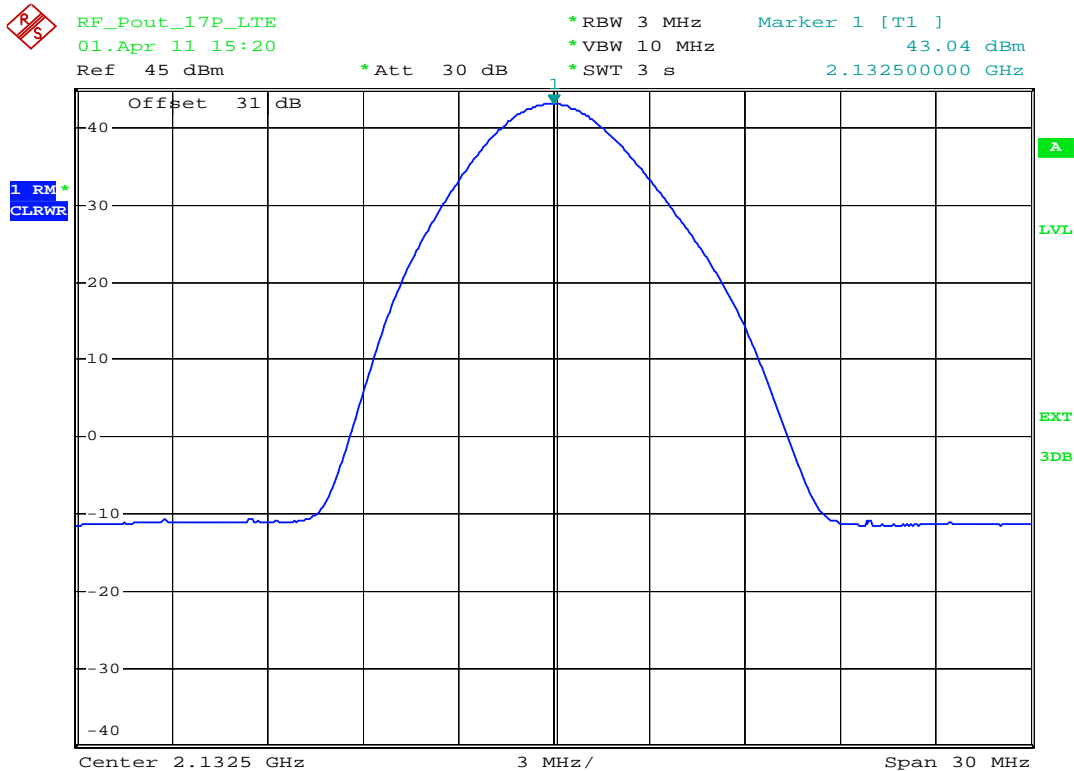

plot 5.3.1.3-#1 RF Power Out: §27.50, §2.1046; Test results; Downlink; LTE Middle

### 5.3.2 Uplink

n.a.

Note: The EUT does not transmit over the air in the uplink direction.

### 5.4 Summary test result

Test result	complies, according the plots above
Tested by:	L.Oskerko
Date:	01.04.2011



## 6 Occupied Bandwidth: §2.1049

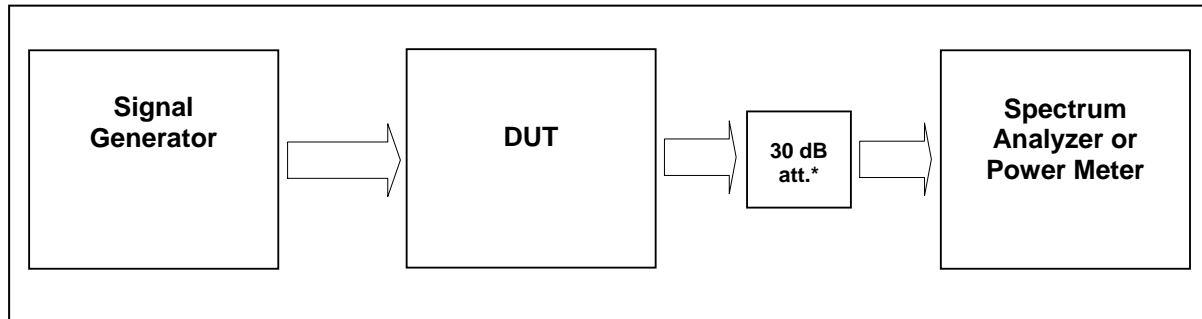

figure 5.4-#1 Test setup: Occupied Bandwidth: §2.1049

Measurement uncertainty	± 0,38 dB
Test equipment used	8890; 8667; 8668; 8848; 7355;

### 6.1 Limit

The spectral shape of the output should look similar to input for all modulations.

### 6.2 Test method

Para. No.2.1049

The occupied bandwidth, that is the frequency bandwidth such that, below its lower and above its upper frequency limits, the mean powers radiated are each equal to 0.5 percent of the total mean power radiated by a given emission shall be measured under the following conditions as applicable:

(h) Transmitters employing digital modulation techniques—when modulated by an input signal such that its amplitude and symbol rate represent the maximum rated conditions under which the equipment will be operated. The signal shall be applied through any filter networks, pseudo-random generators or other devices required in normal service. Additionally, the occupied bandwidth shall be shown for operation with any devices used for modifying the spectrum when such devices are optional at the discretion of the user.

### 6.3 Test results

#### 6.3.1 Downlink

Detector RMS.

Modulation	Measured at	Fcenter / MHz	RBW VBW Span	Occupied Bandwidth / MHz	Plot #
CDMA	Middle	2132,5	30kHz 300kHz 5MHz	1,24	6.3.1.1 #1, #2
WCDMA	Middle	2132,5	100kHz 1MHz 10MHz	4,17	6.3.1.2 #1, #2
LTE	Middle	2132,5	30 kHz 300 kHz 5 MHz	1,10	6.3.1.3 #1,#2

table 6.3-#1 Occupied Bandwidth: §2.1049 Test results Downlink



6.3.1.1 CDMA

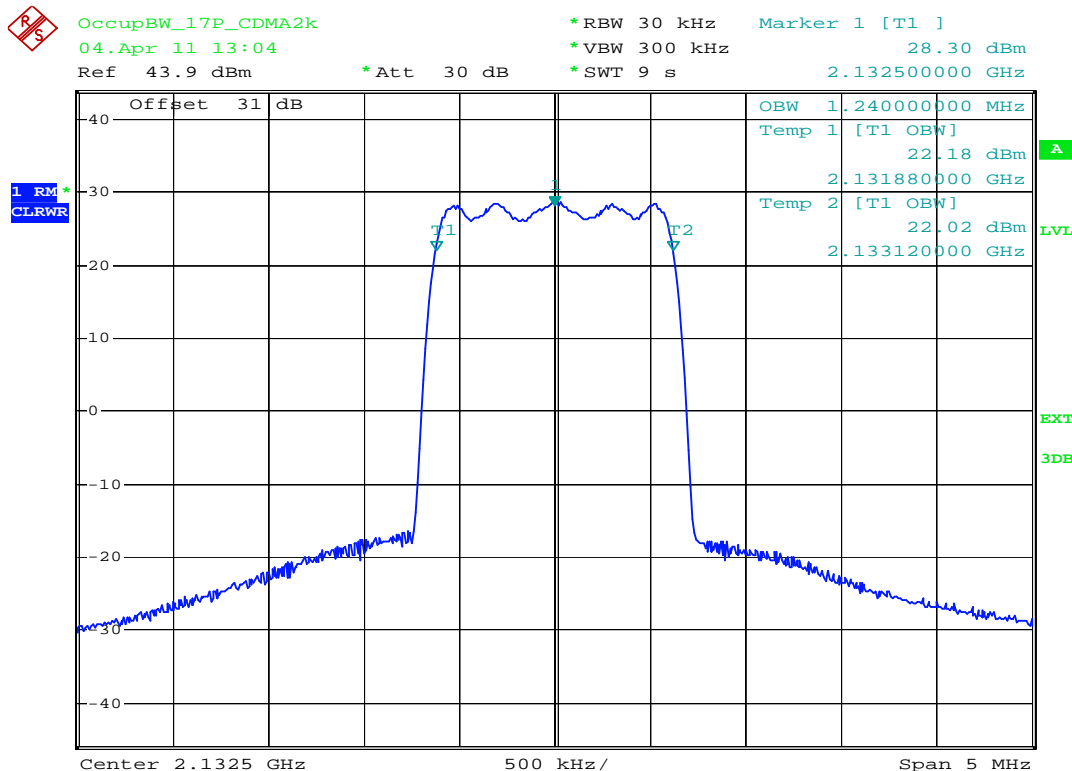

Date: 4.APR.2011 13:04:02

plot 6.3.1.1-#1 Occupied Bandwidth: \$2.1049; Test results; Downlink; CDMA Output

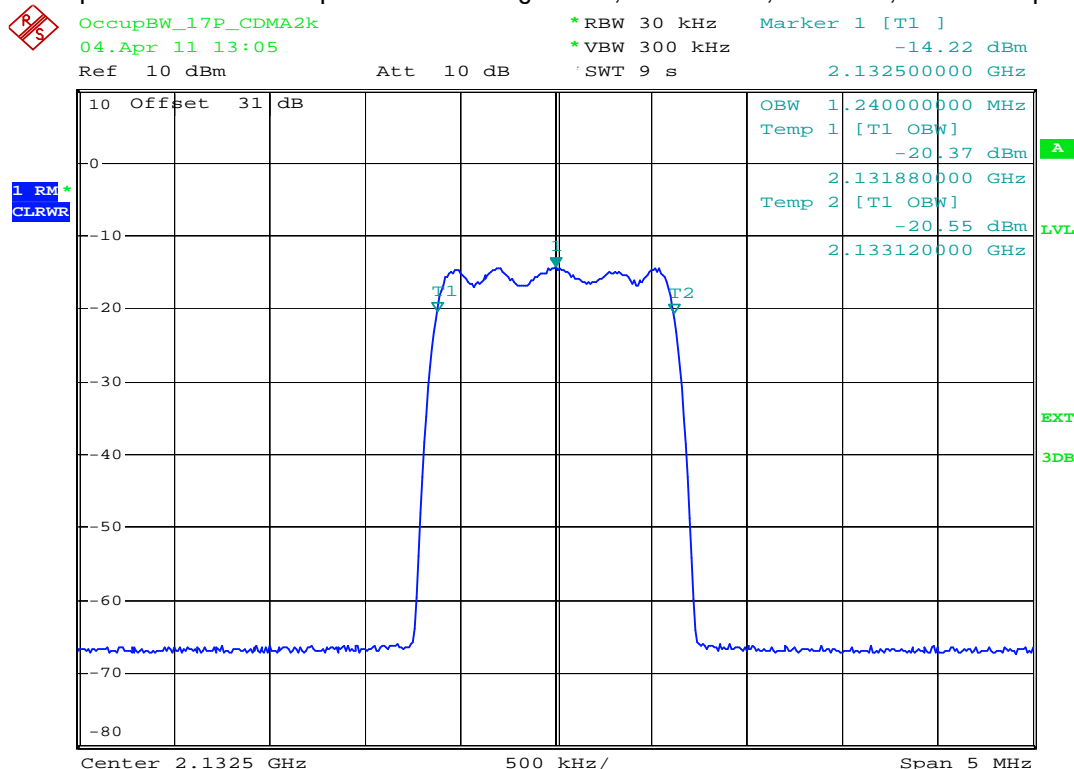

plot 6.3.1.1-#2 Occupied Bandwidth: \$2.1049; Test results; Downlink; CDMA Input





6.3.1.2 W-CDMA

 OccupBW\_17P\_WCDMA \*RBW 30 kHz Marker 1 [T1 ]  
04.Apr 11 13:14 \*VBW 300 kHz 22.70 dBm  
Ref 46.9 dBm \*Att 30 dB \*SWT 9 s 2.132500000 GHz

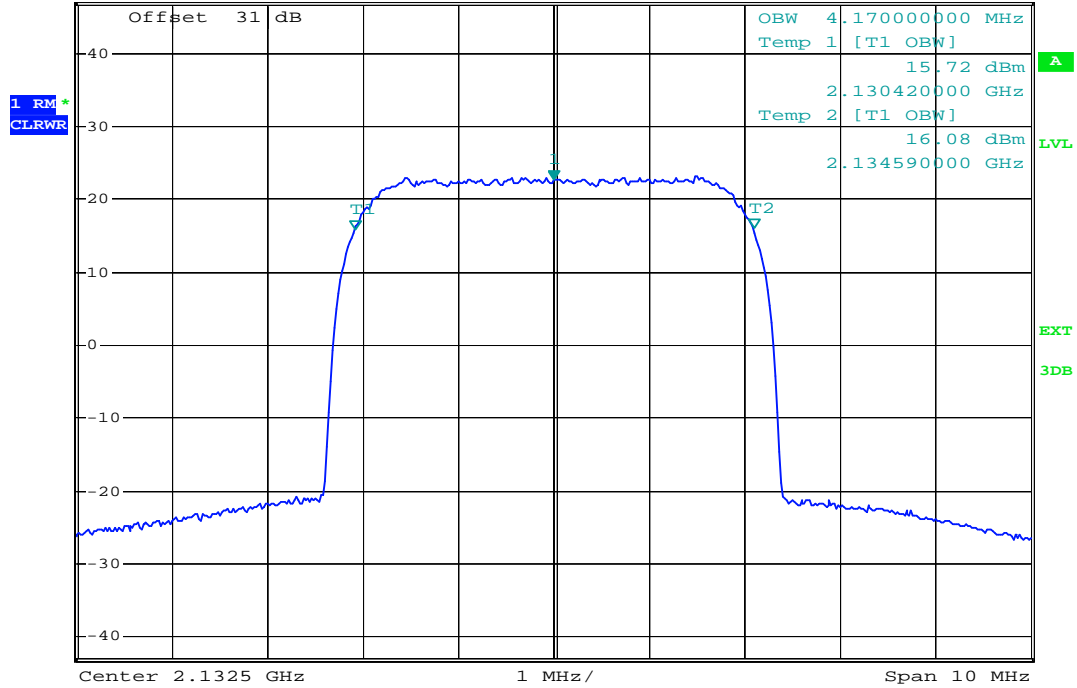

plot 6.3.1.2-#1 Occupied Bandwidth: \$2.1049; Test results; Downlink; W-CDMA Output

 OccupBW\_17P\_WCDMA \*RBW 30 kHz Marker 1 [T1 ]  
04.Apr 11 13:15 \*VBW 300 kHz -19.83 dBm  
Ref 10 dBm Att 10 dB \*SWT 9 s 2.132500000 GHz

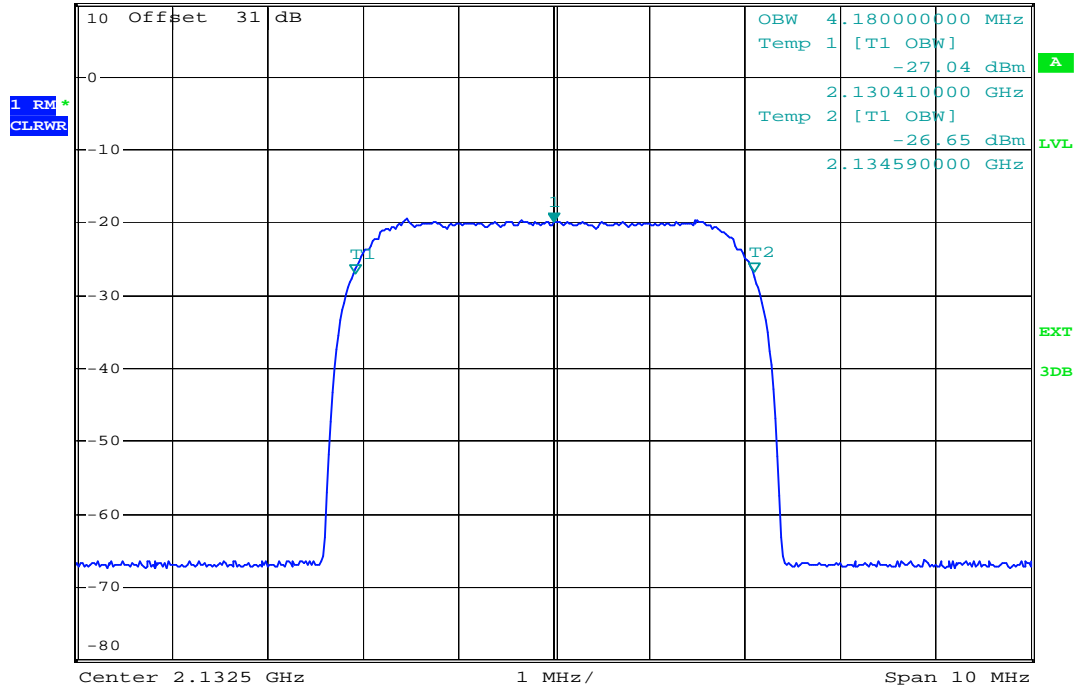

plot 6.3.1.2-#2 Occupied Bandwidth: \$2.1049; Test results; Downlink; W-CDMA Input



6.3.1.3 LTE



OccupBW\_17P\_LTE  
 04.Apr 11 13:25  
 Ref 43.3 dBm \*Att 30 dB \*RBW 30 kHz \*VBW 300 kHz \*SWT 9 s  
 Marker 1 [T1] 25.57 dBm  
 2.13250000 GHz

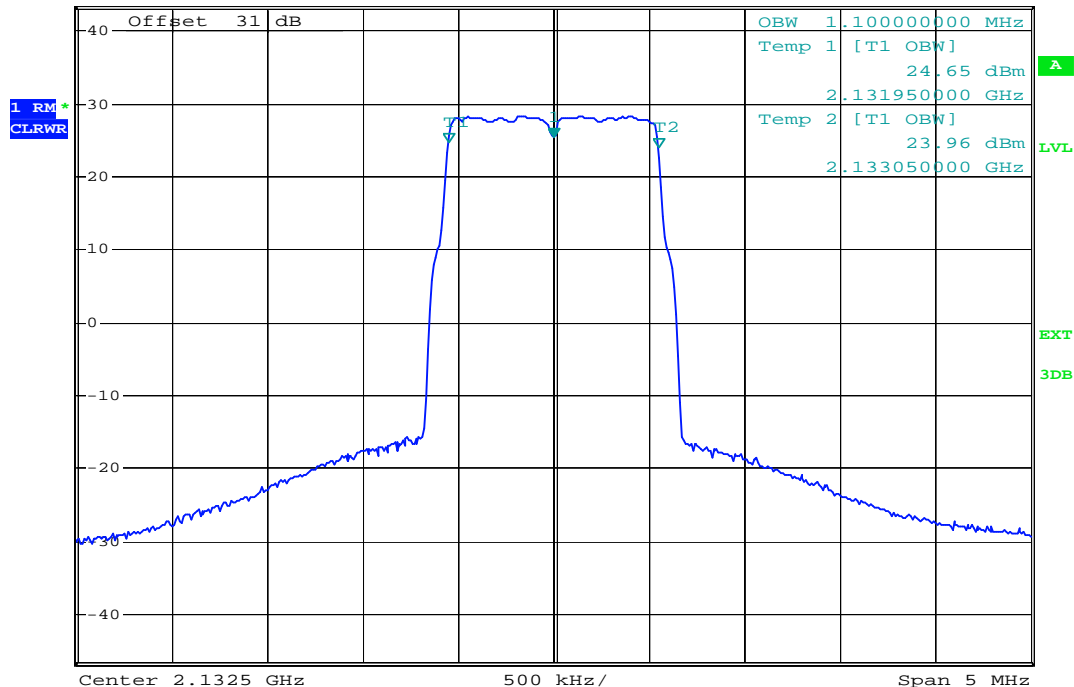

plot 6.3.1.3-#1 Occupied Bandwidth: §2.1049; Test results; Downlink; LTE Output



OccupBW\_17P\_LTE  
 04.Apr 11 13:26  
 Ref 10 dBm Att 10 dB \*RBW 30 kHz \*VBW 300 kHz \*SWT 9 s  
 Marker 1 [T1] -16.98 dBm  
 2.13250000 GHz

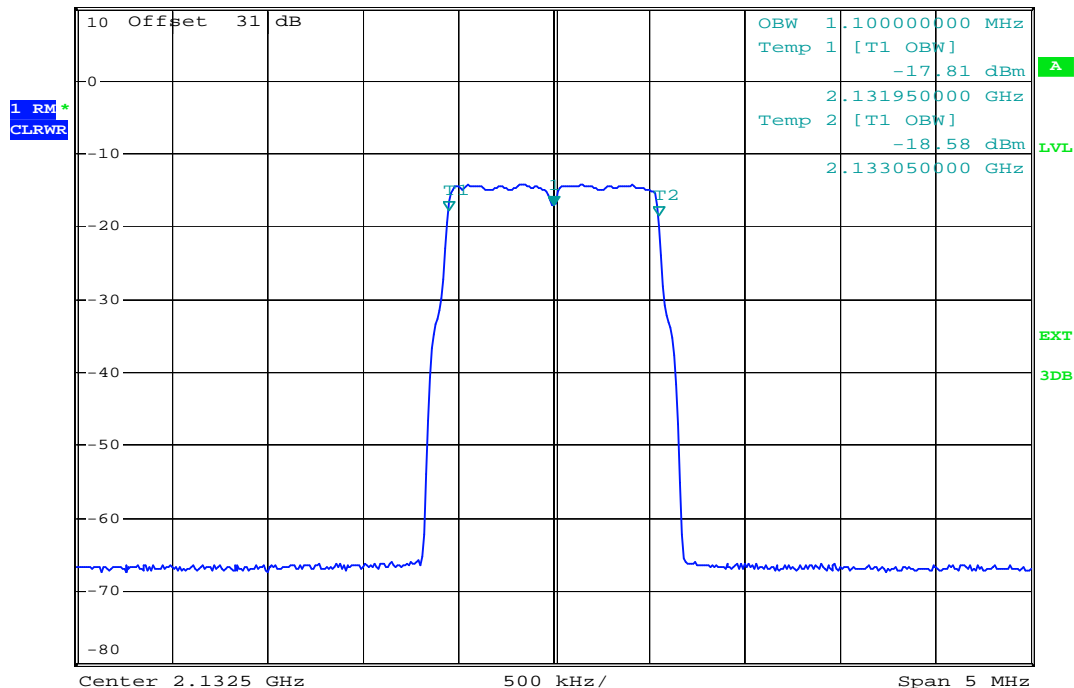

plot 6.3.1.3-#2 Occupied Bandwidth: §2.1049; Test results; Downlink; LTE Input

Test Report No.: 12-147

FCC ID: XS5-M71719P

IC ID: 2237E-M71719P



### 6.3.2 Uplink

n.a.

Note: The EUT does not transmit over the air in the uplink direction.

### 6.4 Summary test result

Test result	complies, according the plots above
Tested by:	L.Oskerko
Date:	04.04.2011



## 7 Spurious Emissions at Antenna Terminals: §27.53, §2.1051

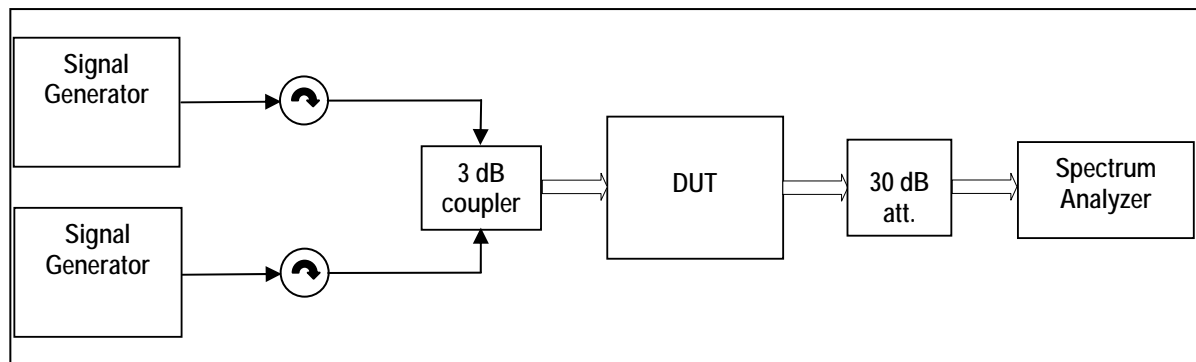

figure 7-#1 Test setup: Spurious Emissions at Antenna Terminals: §27.53, §2.1051

Measurement uncertainty	± 0,54 dB ± 1,2 dB ± 1,5 dB	9 kHz to 3 GHz 3 GHz to 7 GHz 7 GHz to 26 GHz
Test equipment used	8890; 8667; 8668; 8848; 7355; 9126, 9069, 8741, 8667, 8668, 7406	

### 7.1 Limit

Minimum standard:

Para. No.27.53(h)

(h) For operations in the 1710–1755 MHz and 2110–2155 MHz bands, the power of any emission outside a licensee’s frequency block shall be attenuated below the transmitter power (P) by at least  $43 + 10 \log_{10}(P)$  dB.

(1) Compliance with this provision is based on the use of measurement instrumentation employing a resolution bandwidth of 1 megahertz or greater. However, in the 1 megahertz bands immediately outside and adjacent to the licensee’s frequency block, a resolution bandwidth of at least one percent of the emission bandwidth of the fundamental emission of the transmitter may be employed. The emission bandwidth is defined as the width of the signal between two points, one below the carrier center frequency and one above the carrier center frequency, outside of which all emissions are attenuated at least 26 dB below the transmitter power.

(2) When measuring the emission limits, the nominal carrier frequency shall be adjusted as close to the licensee’s frequency block edges, both upper and lower, as the design permits.

(3) The measurements of emission power can be expressed in peak or average values, provided they are expressed in the same parameters as the transmitter power.

### 7.2 Test method

Para. No 2.1051 Measurements required: Spurious emissions at antenna terminals.

The radio frequency voltage or powers generated within the equipment and appearing on a spurious frequency shall be checked at the equipment output terminals when properly loaded with a suitable artificial antenna. Curves or equivalent data shall show the magnitude of each harmonic and other spurious emission that can be detected when the equipment is operated under the conditions specified in § 2.1049 as appropriate. The magnitude of spurious emissions which are attenuated more than 20 dB below the permissible value need not be specified.

[39 FR 5919, Feb. 15, 1974. Redesignated and amended at 63 FR 36599, July 7, 1998]



### 7.3 Test results

#### 7.3.1 Downlink

<1MHz from Band Edge

Detector: RMS.

Modulation	Measured at Band Edge	Carriers	RBW VBW Span	Max. level (dBm)	Plot -
WCDMA	Lower Edge	2110,775 MHz	30kHz 300kHz 6MHz	-19,86	7.3.1.1 #1
	Upper Edge	2112,025 MHz 2152,975 MHz 2154,225 MHz			7.3.1.1 #2
CDMA	Lower Edge	2112,6 MHz	100kHz 1MHz 15MHz	-24,44	7.3.1.2 #1
	Upper Edge	2117,6 MHz 2147,4 MHz 2152,4 MHz			7.3.1.2 #2
LTE	Lower Edge	2110,7 MHz	30kHz 300kHz 6MHz	-18,47	7.3.1.3 #1
	Upper Edge	2112,1 MHz 2152,9 MHz 2154,3 MHz			7.3.1.3 #2

table 7.3-#1 Spurious Emissions at Antenna Terminals: §27.53, §2.1051 Test results Downlink <1MHz from Band Edge

>1MHz from Band Edge

Detector: RMS.

Modulation	Carrier at	Carrier	Max. level (dBm)	RBW VBW Frequency range	Plot -
CDMA	Middle	2132,5 MHz	< -40	1MHz 3MHz 30MHz – 22GHz	7.3.1.4 #1
WCDMA	Middle	2132,5 MHz	< -40	1MHz 3MHz 30MHz – 22GHz	7.3.1.5 #1
LTE	Middle	2132,5 MHz	< -40	1MHz 3MHz 30MHz – 22GHz	7.3.1.6 #1

table 7.3-#2 Spurious Emissions at Antenna Terminals: §27.53, §2.1051 Test results Downlink >1MHz from Band Edge



### 7.3.1.1 WCDMA < 1MHz to band edge

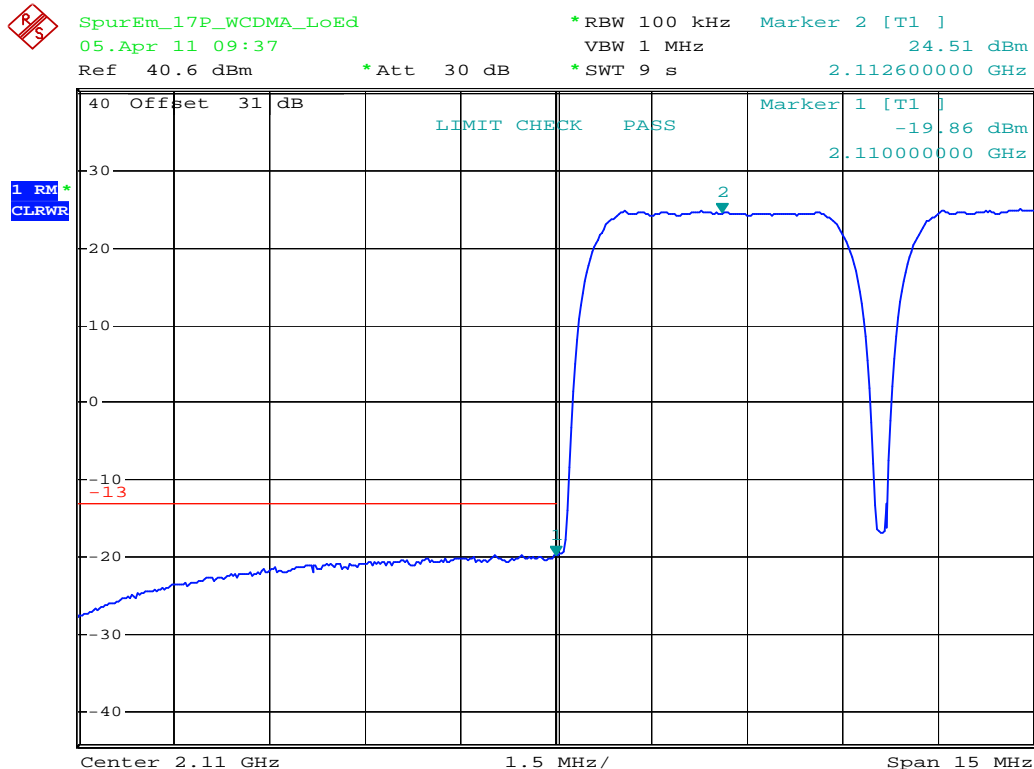

plot 7.3.1.1-#1 Spurious Emissions at Antenna Terminals: §27.53, §2.1051; Test results; Downlink; WCDMA < 1MHz to band edge Lower Band Edge

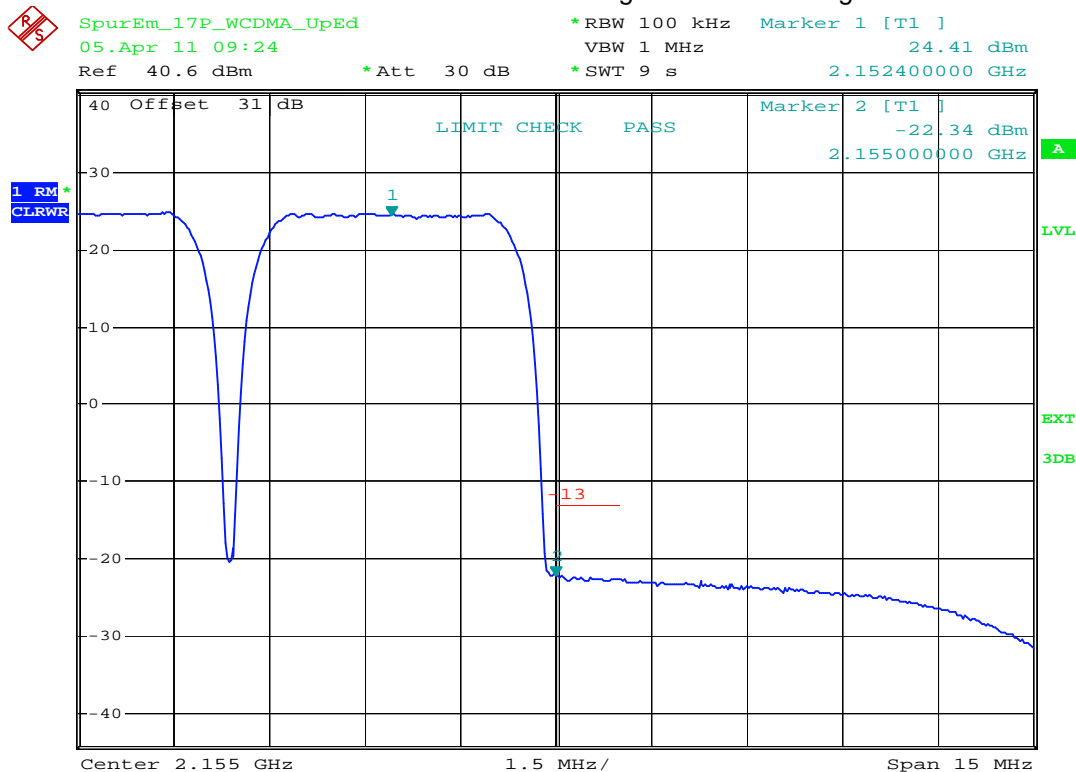

plot 7.3.1.1-#2 Spurious Emissions at Antenna Terminals: §27.53, §2.1051; Test results; Downlink; WCDMA < 1MHz to band edge Upper Band Edge



### 7.3.1.2 CDMA < 1MHz to band edge

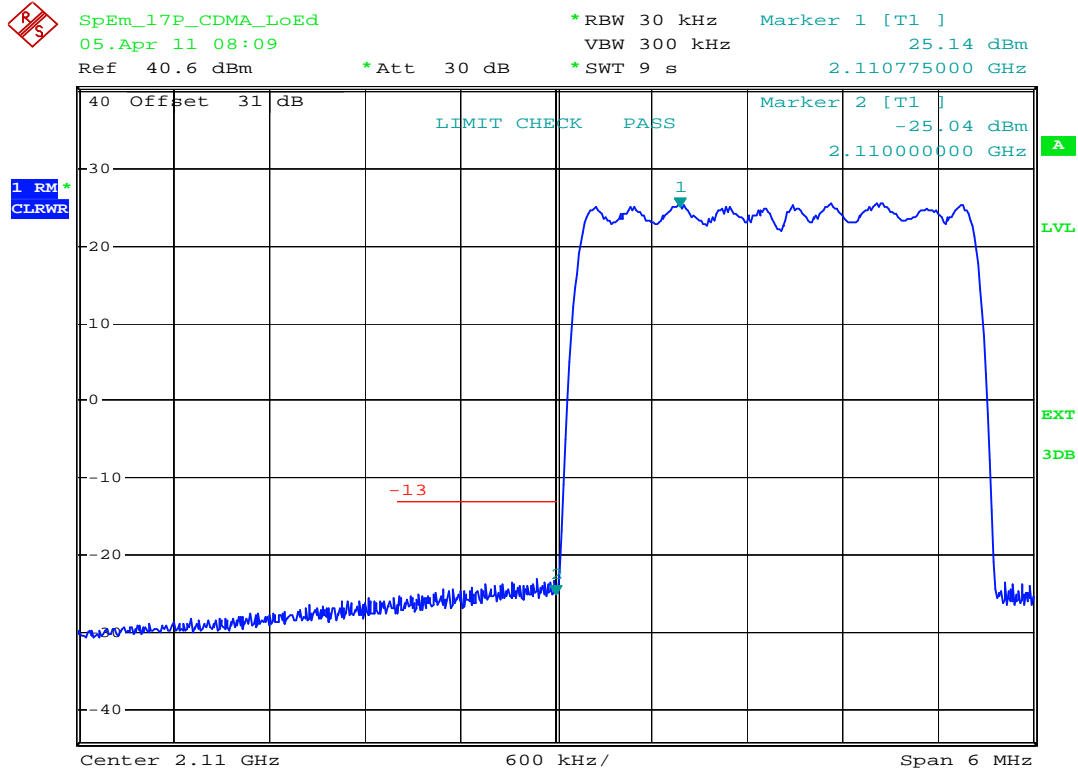

plot 7.3.1.2-#1 Spurious Emissions at Antenna Terminals: §27.53, §2.1051; Test results; Downlink; CDMA < 1MHz to band edge Lower Band Edge

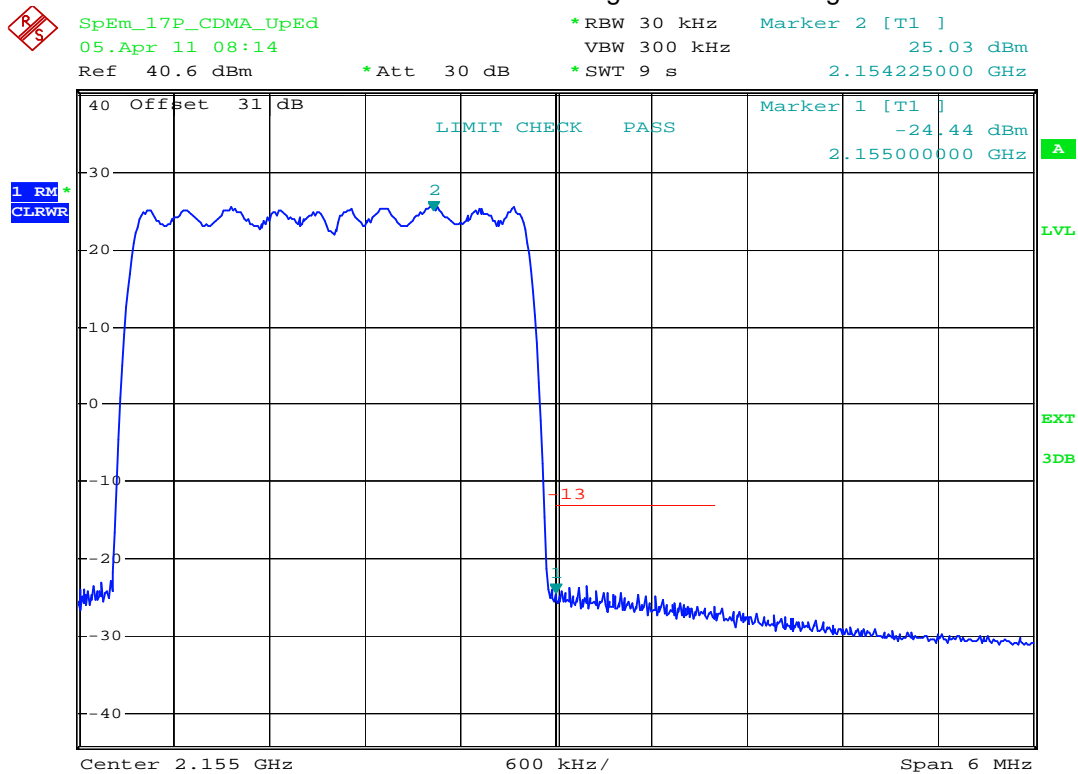

plot 7.3.1.2-#2 Spurious Emissions at Antenna Terminals: §27.53, §2.1051; Test results; Downlink; CDMA < 1MHz to band edge Upper Band Edge



### 7.3.1.3 LTE < 1MHz to band edge

**Pass** Emission Measurement 04.Apr 11 17:17  
Ref 39.7 dBm \*Att 30 dB \*RBW 30 kHz \*SWT 6 s  
Marker 2 [T1] 22.51 dBm 2.110700000 GHz  
VBW 300 kHz

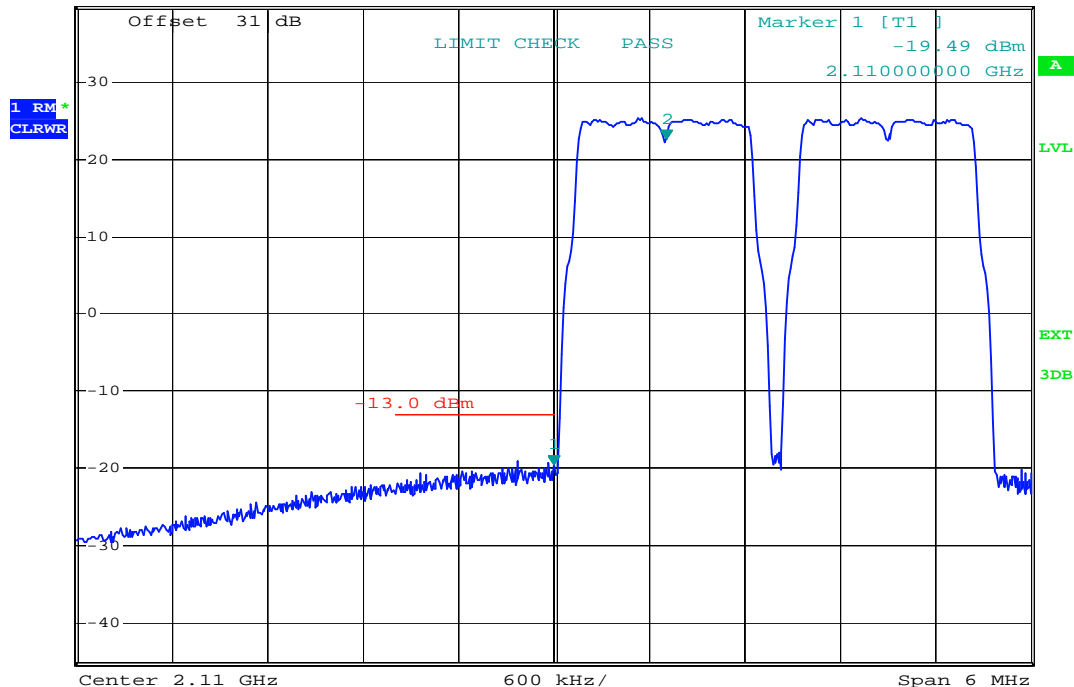

plot 7.3.1.3-#1 Spurious Emissions at Antenna Terminals: §27.53, §2.1051; Test results; Downlink; LTE < 1MHz to band edge Lower Band Edge

**Pass** Emission Measurement 04.Apr 11 17:18  
Ref 40.4 dBm \*Att 30 dB \*RBW 30 kHz \*SWT 4 s  
Marker 1 [T1] -18.47 dBm 2.155000000 GHz  
VBW 300 kHz

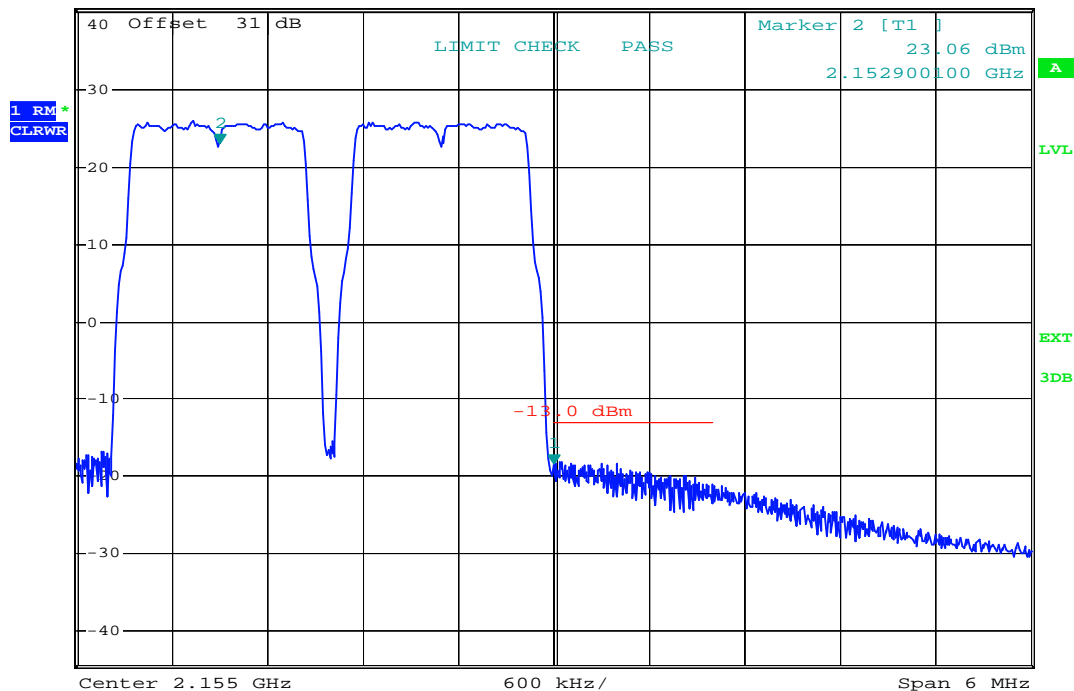

plot 7.3.1.3-#2 Spurious Emissions at Antenna Terminals: §27.53, §2.1051; Test results; Downlink; LTE < 1MHz to band edge Upper Band Edge





### 7.3.1.4 CDMA > 1MHz to band edge

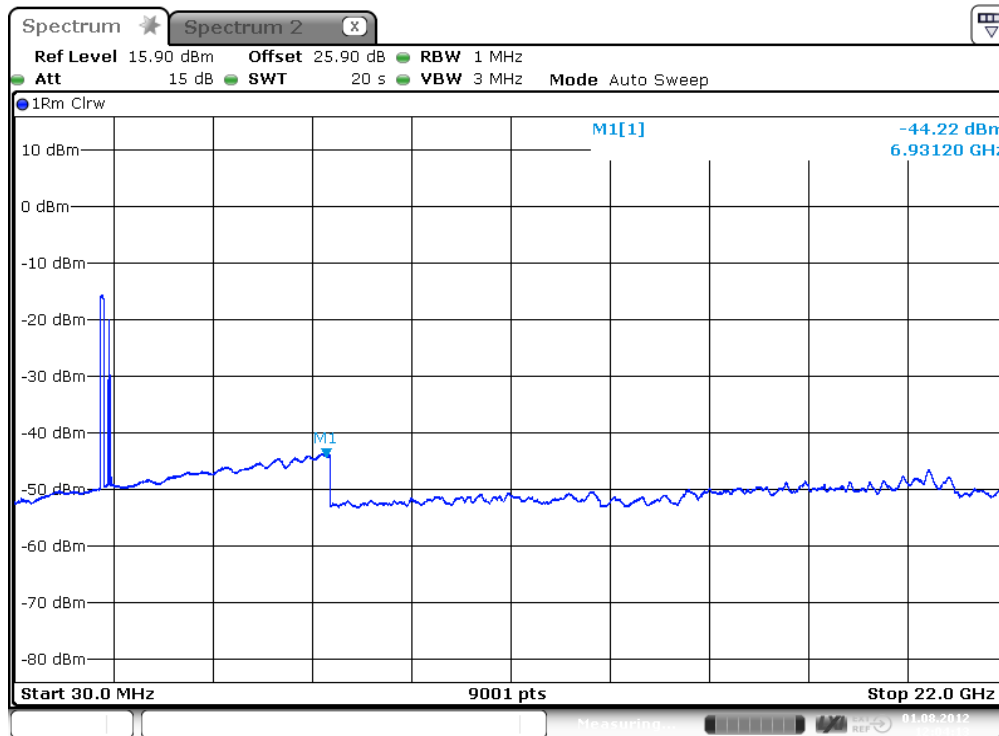

Date: 1.AUG.2012 12:04:14

plot 7.3.1.4-#1 Spurious Emissions at Antenna Terminals: §27.53, §2.1051; Test results; Downlink; CDMA > 1MHz to band edge; carrier (2132,5MHz) notched

### 7.3.1.5 W-CDMA > 1MHz to band edge

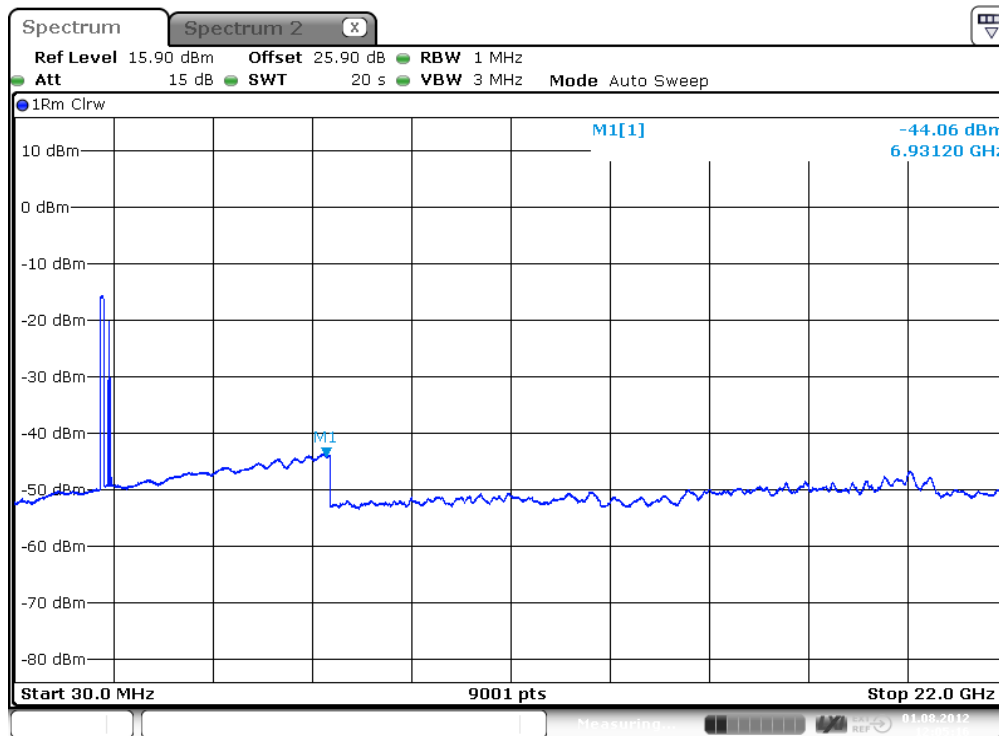

Date: 1.AUG.2012 12:05:17

plot 7.3.1.5-#1 Spurious Emissions at Antenna Terminals: §27.53, §2.1051; Test results; Downlink; W-CDMA > 1MHz to band edge; carrier (2132,5MHz) notched



**7.3.1.6 LTE > 1MHz to band edge**

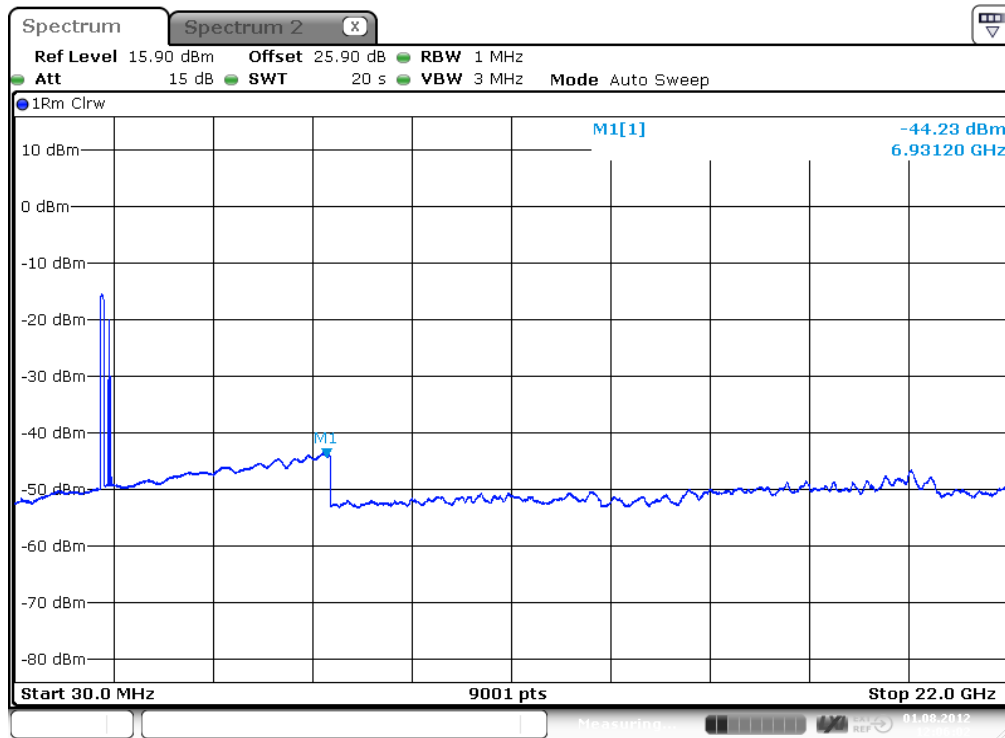

plot 7.3.1.6-#1 Spurious Emissions at Antenna Terminals: §27.53, §2.1051; Test results; Downlink; LTE > 1MHz to band edge; carrier (2132,5MHz) notched

**7.3.2 Uplink**

n.a.

Note: The EUT does not transmit over the air in the uplink direction.

**7.4 Summary test result**

Test result	complies, according the plots above
Tested by:	L. Oskerko
Date:	05.04.2011
Tested by:	W. Meir
Date:	1.08.2008

## 8 Transmitter Output Power: IC RSS-139, RSS-GEN

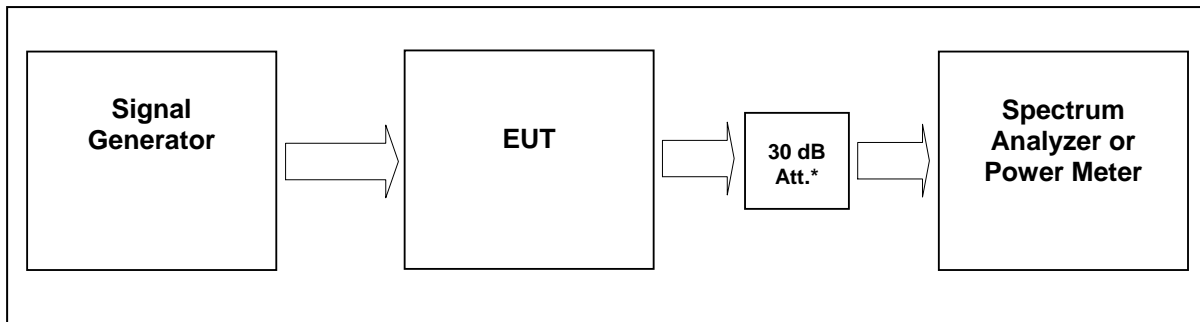

figure 7.4-#1 Test setup: Transmitter Output Power: IC RSS-139, RSS-GEN

Measurement uncertainty	± 0,38 dB
Test equipment used	9126, 9069, 8741, 8667, 8668, 7406

### 8.1 Limit

Minimum standard:

IC RSS-139 clause 6.4

Consult SRSP-513 for e.i.r.p. limits on fixed and base stations operating in the 2110-2155 MHz band.

In addition, when the transmitter power is measured in terms of average value, the peak-to-average ratio of the power shall not exceed 13 dB.

IC SRSP-513 clause 5.1.1

For base stations with a channel bandwidth greater than 1 MHz, the maximum e.i.r.p. is limited to 3280 watts/MHz e.i.r.p. (i.e., no more than 3280 watts e.i.r.p. in any 1 MHz band segment) with an antenna height above average terrain (HAAT) up to 300 metres. Fixed or base stations operating in urban areas are limited to a maximum allowable e.i.r.p. of 1640 watts/MHz e.i.r.p.

### 8.2 Test method

IC RSS-139 clause 4.1

The transmitter power can be measured in peak or average value. If the transmitter power to be measured is in peak value, the transmitter power shall be measured over any interval of continuous transmission using an instrument calibrated in terms of a root-mean-square-equivalent voltage. The measurement results shall be properly adjusted for any instrument limitation, such as detector response times, sensitivity, limited resolution bandwidth capability when compared to the emission bandwidth, etc., so as to obtain the maximum transmit output power of the emission over the channel bandwidth.

### 8.3 Test results

Transmitter Output Power results see

clause 5 RF Power Out: §27.50, §2.1046sub clause 5.3



Test results

8.3.1 Downlink

Modulation	Measured at	Peak – to - average (dB)	Plot -
CDMA	2132,5 MHz	9,36	5.3.1.18 .3.1.1 #1
WCDMA	2132,5 MHz	10,23	8.3.1.2 #1
LTE	2132,5 MHz	9,05	8.3.1.3 #1
Maximum peak to average = 10.2 dB			
Limit peak to average = 13 dB			

table 8.3.1-#1 Transmitter Output Power: IC RSS-139, RSS-GEN Test results Downlink Peak - to - average



8.3.1.1 CDMA

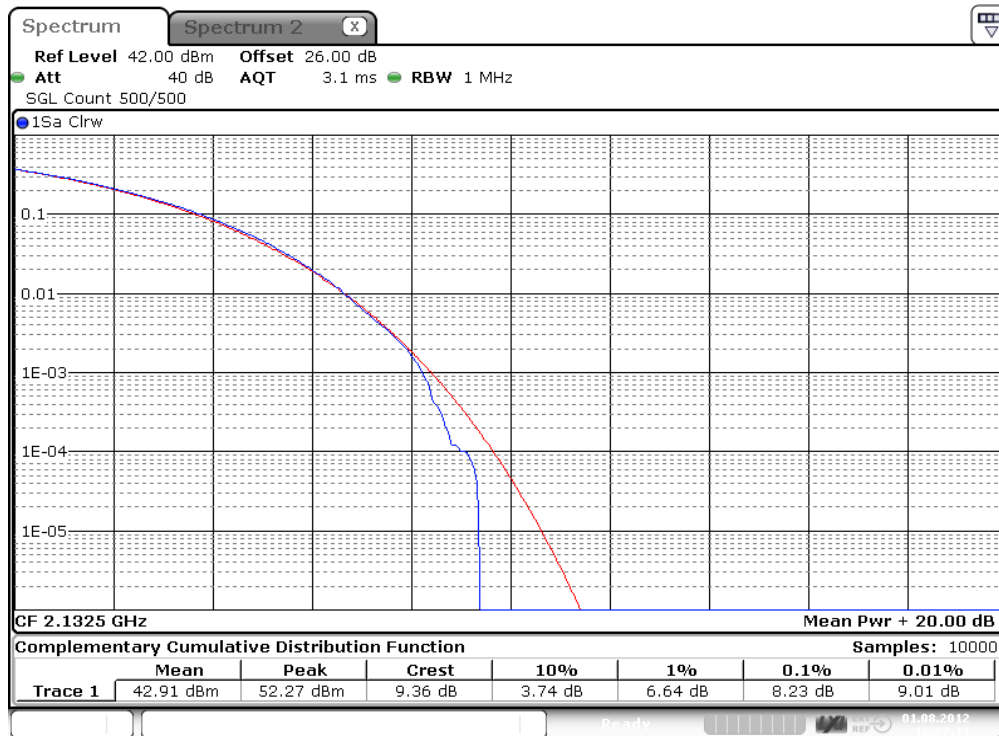

Date: 1.AUG.2012 16:27:12

plot 8.3.1.1-#1 Transmitter Output Power: IC RSS-139, RSS-GEN; Test results; Downlink; CDMA Middle Peak - to - average

8.3.1.2 WCDMA



Date: 1.AUG.2012 16:44:31

plot 8.3.1.2-#1 Transmitter Output Power: IC RSS-139, RSS-GEN; Test results; Downlink; WCDMA Middle Peak - to - average



### 8.3.1.3 LTE



Date: 1.AUG.2012 16:46:04

plot 8.3.1.3-#1 Transmitter Output Power: IC RSS-139, RSS-GEN; Test results; Downlink; LTE Middle Peak - to - average

### 8.3.2 Uplink

n.a.

Note: The EUT does not transmit over the air in the uplink direction.

### 8.4 Summary test result

Test result	complies, according the plots above
Tested by:	W. Meir
Date:	1.08.2012



## 9 Transmitter Unwanted Emissions: IC RSS-139

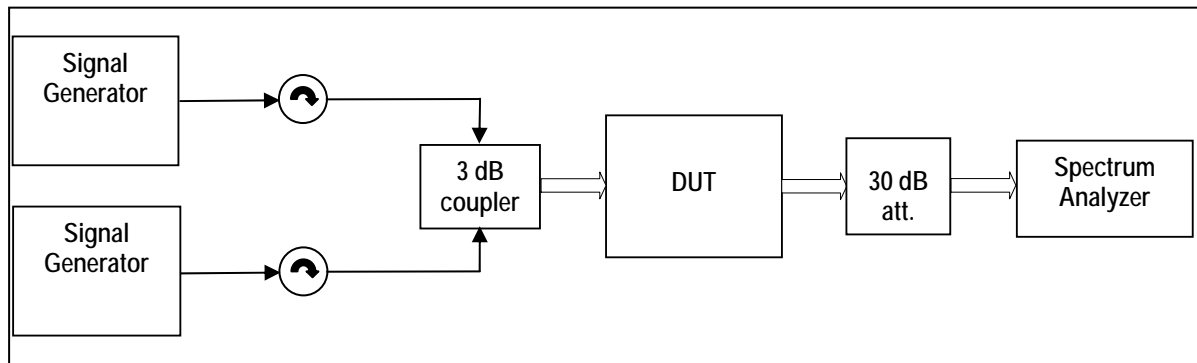

figure 9-#1 Test setup: Transmitter Unwanted Emissions: IC RSS-139

Measurement uncertainty	± 0,54 dB ± 1,2 dB ± 1,5 dB	9 kHz to 3 GHz 3 GHz to 7 GHz 7 GHz to 26 GHz
Test equipment used	9126, 9069, 8667, 8668, 7406;	

### 9.1 Limit

IC RSS-139 clause 6.5

(i) In the first 1.0 MHz bands immediately outside and adjacent to the equipment's operating frequency block, the emission power per any 1% of the emission bandwidth shall be attenuated below the transmitter output power P (in watts) by at least  $43 + 10 \log 10 (P)$ , dB.

(ii) After the first 1.0 MHz outside the equipment's operating frequency block, the emission power in any 1 MHz bandwidth shall be attenuated below the transmitter output power P (in watts) by at least  $43 + 10 \log 10 (P)$ , dB.

### 9.2 Test method

IC RSS-139 clause 4.2

The emission limits shall be measured with the carrier frequency set at both the highest settable frequency and lowest settable frequency permitted by the design of the equipment.

### 9.3 Test results

see 7 Spurious Emissions at Antenna Terminals: §27.53, §2.1051 subclause 7.3 Test results

for (i) see table 7.3-#1

for (ii) see table 7.3-#2

Test Report No.: 12-147

FCC ID: XS5-M71719P

IC ID: 2237E-M71719P

---



## 10 Receiver Spurious Emissions: IC RSS-139A

### 10.1 Limit

IC RSS-139 clause 6.6

Receiver spurious emissions shall comply with the limits specified in RSS-Gen.

Comment:

Receiver Spurious Emissions are not measured, since the Repeater has only one antenna port to transmit and receive at the same time (bi-directional amplifier)

The worst case for emission considerations is when the repeater is transmitting.

For transmitter unwanted emission test results see 9 Transmitter Unwanted Emissions: IC RSS-139.



Test Report No.: 12-147

FCC ID: XS5-M71719P

IC ID: 2237E-M71719P



## 11 Field Strength of Spurious Emissions: §27.53, §2.1053, RSS-139



picture 8.1: label



picture 8.2: Test setup: Field Strength Emission <1 GHz @3m in the FAC

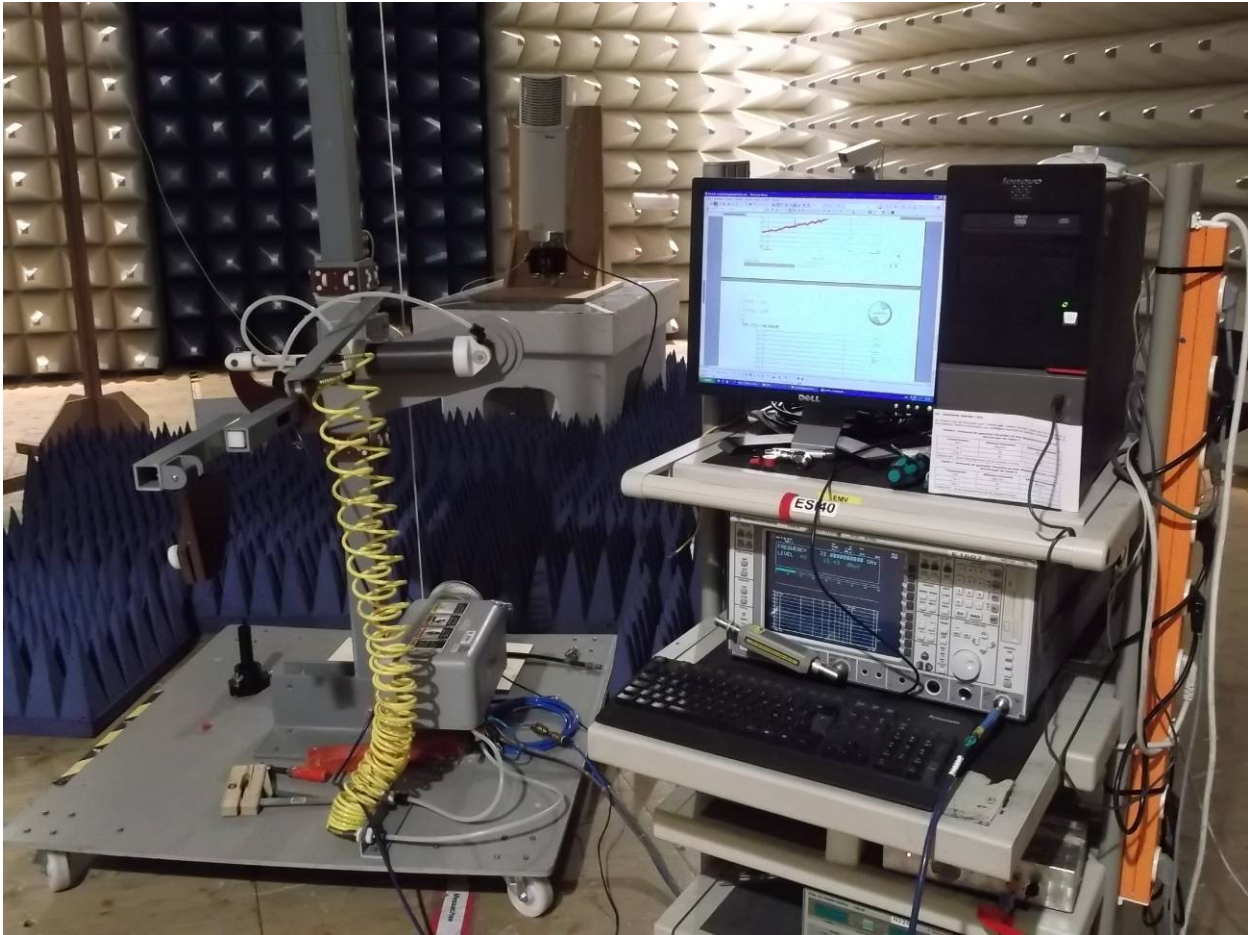

**picture 8.3:** Test setup: Field Strength Emission >1 GHz @3m in the FAC

Test Report No.: 12-147

FCC ID: XS5-M71719P

IC ID: 2237E-M71719P



This clause specifies requirements for the measurement of radiated emission.

Frequency range	Distance: EUT <-> antenna / location	Limit	Test method
30 MHz - 1 GHz	3 metres / FAC	FCC 47 CFR Part 27.53	TIA/EIA-603-C:2004
		IC RSS-139 sec. 6.4	
1 GHz – 22 GHz		FCC 47 CFR Part 27.53	
		IC RSS-139 sec. 6.4	

**Test equipment used:**

Designation	Type	Manufacturer	Invent.-no.	Cal.-date	due Cal.-date	used
EMI test receiver	ESI40	Rohde & Schwarz	E1687	22.12.2011	21.12.2012	X
Antenna	CBL 6111	Chase	K1026	29.03.2012	29.03.2013	X
Antenna	HL 025	R&S	K809	19.12.2011	19.12.2012	X
Preamplifier	AFS4-00102000	Miteq	K838	05.06.2012	05.06.2013	X
RF Cable	Sucoflex 100	Suhner	K1742	23.05.2012	23.05.2013	X

The REMI version 2.135 has been used for max search.

**Test set-up:**

Test location: FAC  
The Fully Anechoic Chamber (FAC) fulfils the requirements of ANSI C63.4 and CISPR 16-1-4 with regards to NSA and SVSWR.

Test Voltage: 115V / 60 Hz  
Type of EUT: Wall mounted

**Measurement uncertainty:**

Measurement uncertainty expanded (95% or K=2)	± 4,7 dB for ANSI C63.4 measurement ± 0,5 dB for TIA-603 measurement
--	---

## 11.1 Method of Measurement

### Measurement procedure. TIA-603-C

The antenna substitution method is used to determine the equivalent radiated power at spurious frequencies. The spurious emissions are measured at a distance of 3 meters. The EUT is then replaced with a reference substitution antenna with a known gain referenced to a dipole. This antenna is fed with a signal at the spurious frequency. The level of the signal is adjusted to repeat the previously measured level. The resulting eirp is the signal level fed to the reference antenna corrected for gain referenced to an isotropic dipole (see Figure 7.2).

From KDB (AMPLIFIER, BOOSTER, AND REPEATER REMINDER SHEET):

Radiated spurs (enclosure) – Use of CW signal (low, mid, and high freq.) is acceptable rather than all modulations.

The maximum RFI field strength was determined during the measurement by rotating the turntable ( $\pm 180$  degrees) and varying the height of the receive antenna ( $h = 1 \dots 4$  m) as like defined in ANSI C63.4. A measurement receiver has been used with a RBW 120 kHz up to 1 GHz and 1 MHz above 1 GHz. Steps with during pre measurement was half the RBW.

Both, the Fully Anechoic Chamber (FAC) and the Semi Anechoic Chamber (SAC) fulfil the requirements of ANSI C63.4 and CISPR 16-1-4 with regards to NSA and SVSWR.

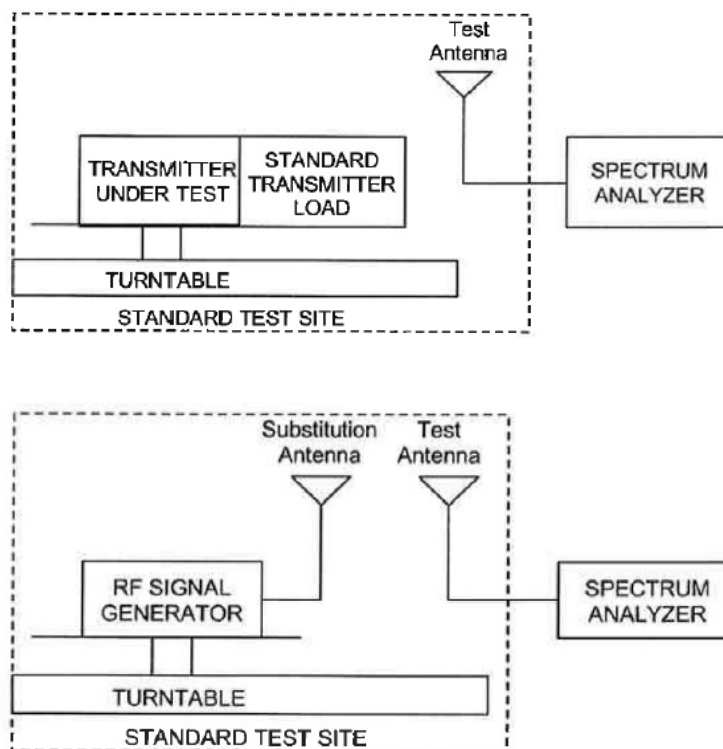

Figure #7.2 Substitution methods TIA/EIA-603-C

Test Report No.: 12-147

FCC ID: XS5-M71719P

IC ID: 2237E-M71719P



## 11.2 Limit §27.53 (h)

The Emission limit is -13dBm.

## 11.3 Receiver Settings

	up to 1 GHz	above 1 GHz
Measurement bandwidth	120 kHz	1 MHz
Step width	60 kHz	500 kHz
Dwell time	20ms	
Detector	Peak	Peak

## 11.4 Climatic values in the lab

Temperature: 22°  
Relative Humidity: 46%  
Air-pressure: 1004 hPa



## 11.5 Test results

### 11.5.1 30 MHz to 1 GHz Downlink (Bottom – Middle – Top)

B/M/T: 2110 MHz / 2132.5 MHz / 2155 MHz (Operation with maximum composite power)

Horizontal / **Vertikal**

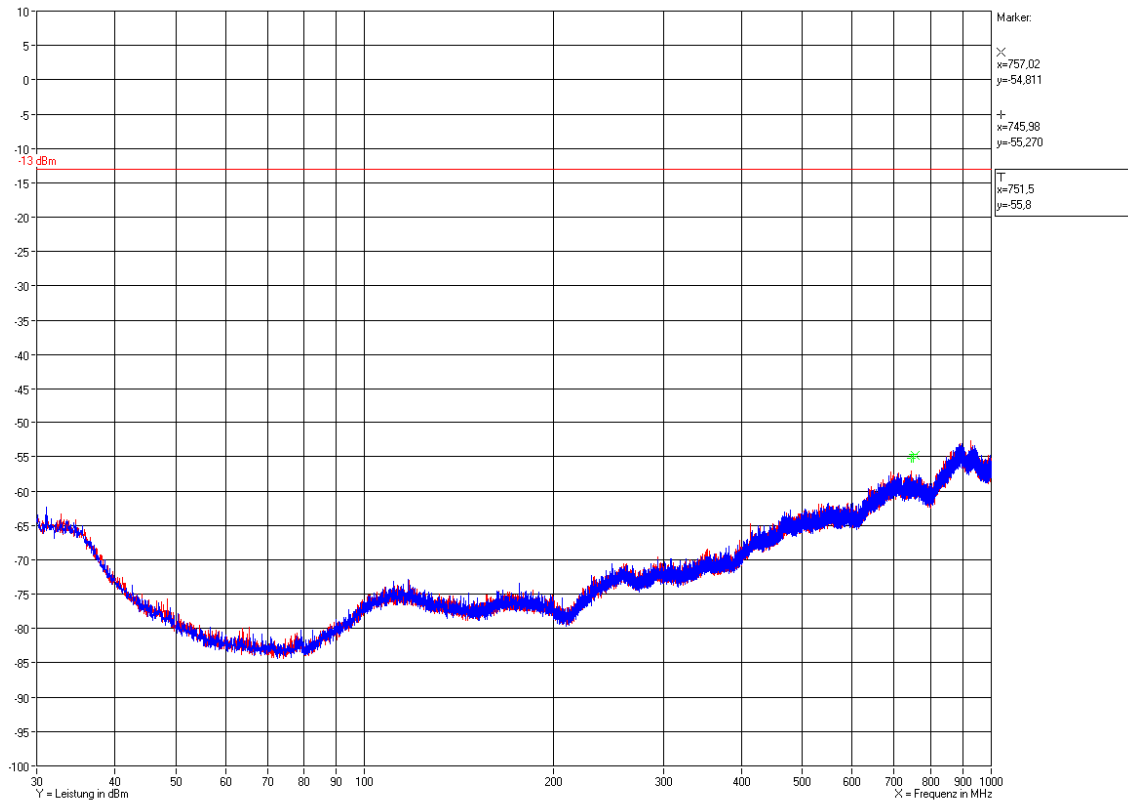

Measurement with Peak detector, BW 120KHz,  
Step width 60 kHz, dwell time 20ms

Antenna height: 1.55m; all positions of the turn  
table measured with max. hold function

Polarization: Horizontal / **Vertikal**

No peak detected 20dB above noise



Test Report No.: 12-147

FCC ID: XS5-M71719P

IC ID: 2237E-M71719P



### 11.5.2 30 MHz to 1 GHz Downlink (middle of all bands)

f = 737 MHz / 751,5 MHz / 1962,5MHz / 2132,5MHz

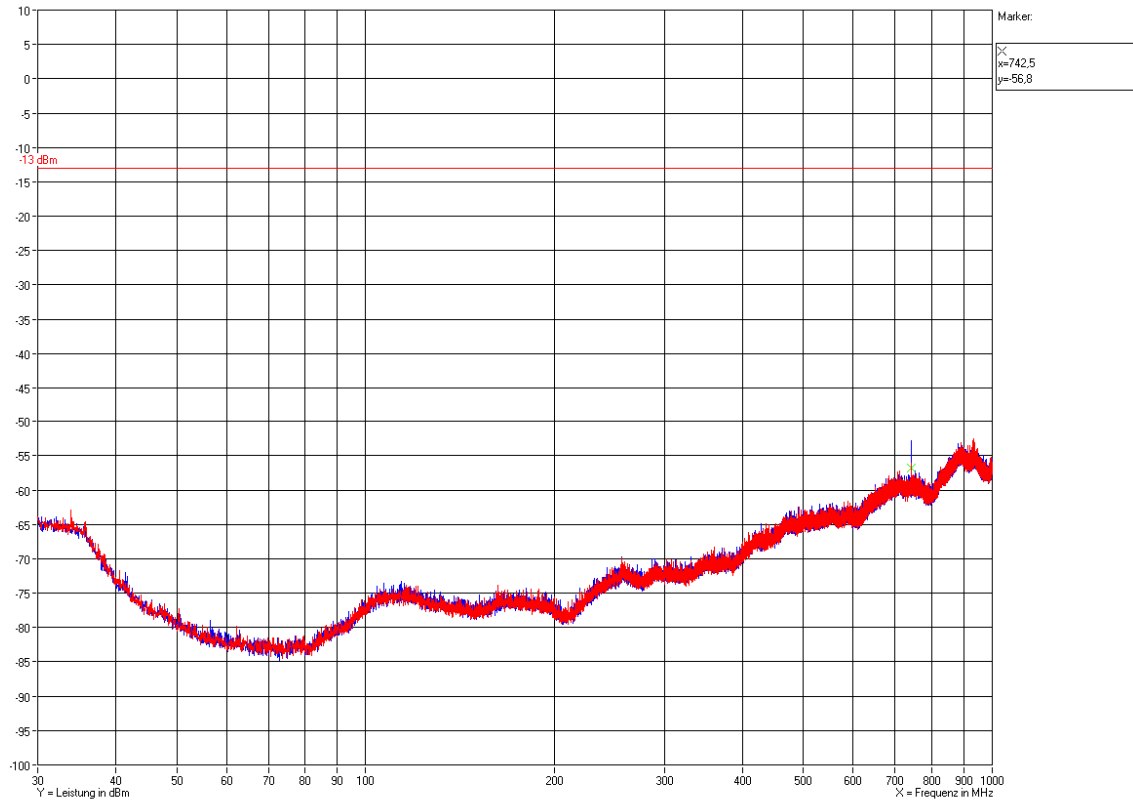

Measurement with Peak detector, BW 120KHz,  
Step width 60 kHz, dwell time 20ms

Antenna height: 1.55m; all positions of the turn  
table measured with max. hold function

Polarization: **Horizontal** / **Vertical**

Test Report No.: 12-147

FCC ID: XS5-M71719P

IC ID: 2237E-M71719P



### 11.5.3 1 GHz to 22 GHz Downlink (Bottom – Middle – Top)

B/M/T: 2110 MHz / 2132.5 MHz / 2155 MHz (Operation with maximum composite power)

Horizontal / Vertikal

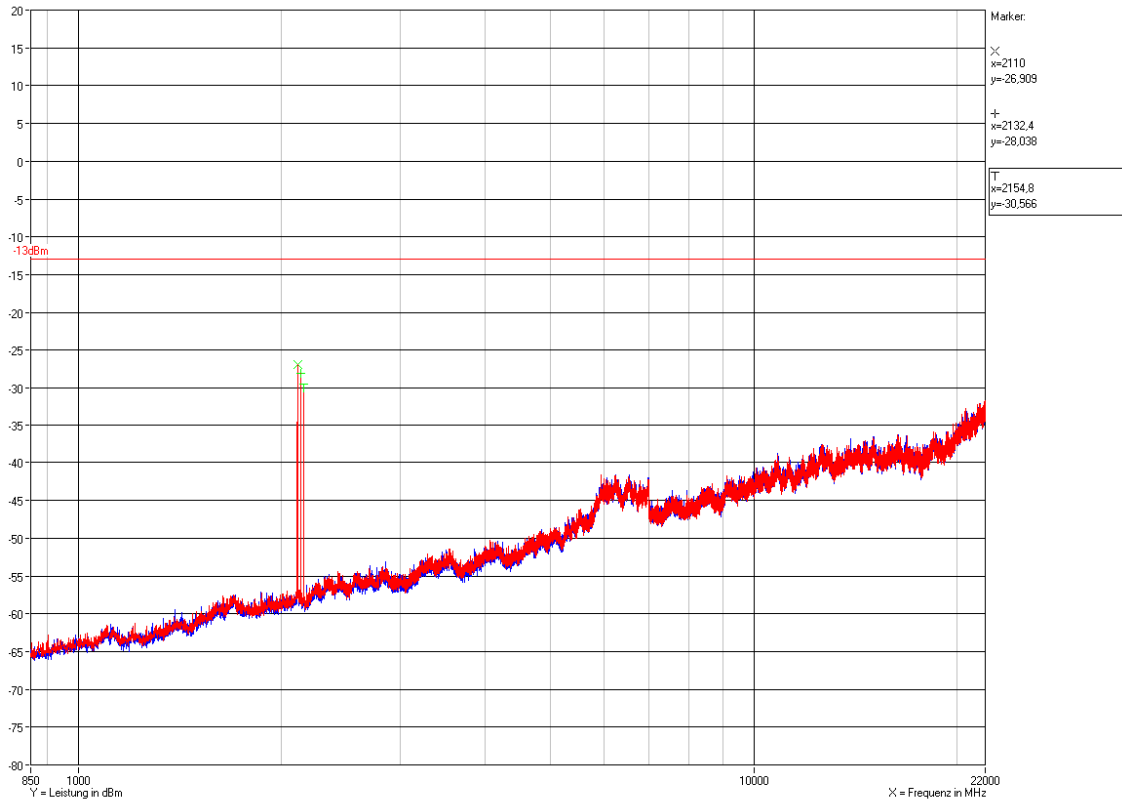

Measurement with Peak detector, BW 1MHz, Step width 500 kHz, dwell time 20ms

Antenna height: 1.55m; all positions of the turn table measured with max. hold function

Polarization: Horizontal / Vertikal





11.5.4 1 GHz to 22 GHz Downlink (middle of all bands)

f = 737 MHz / 751,5 MHz / 1962,5MHz / 2132,5MHz

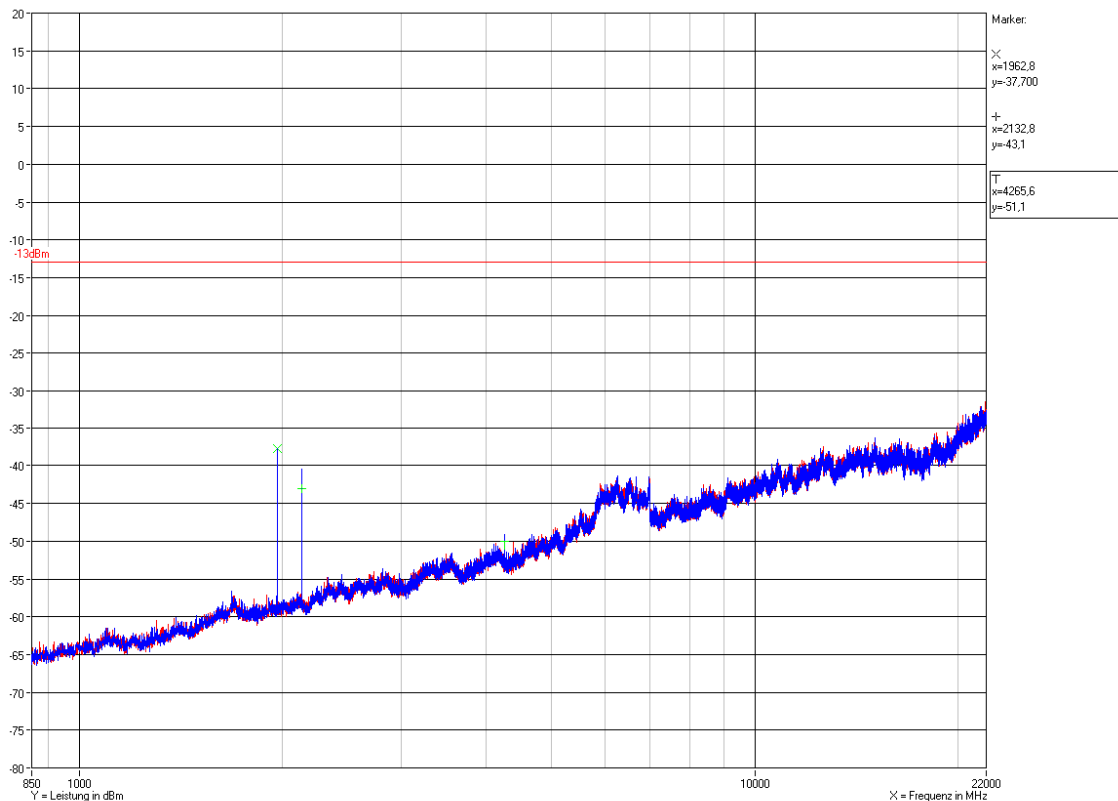

Measurement with Peak detector, BW 1MHz, Step width 500 kHz, dwell time 20ms

Antenna height: 1.55m; all positions of the turn table measured with max. hold function

Polarization: **Horizontal** / **Vertical**

**The radiated spurious emission requirements have been met in all frequency bands.**

Zahlmann 06.08.2012

12 History

Revision	Modification	Date	Name
01.00	Initial Test report	08.08.2011	T. Zahlmann

Test Report No.: 12-147

FCC ID: XS5-M71719P

IC ID: 2237E-M71719P

---



**\*\*\*\*\* End of test report \*\*\*\*\***