

FCC Measurement/Technical Report on

ION-M23 SDARS DC 1 – Sector Passive

SDARS Remote Optical System

FCC ID: XS5-M23SDARS1S

IC: -

Test Report Reference: MDE_COMSC_1901_FCCa

Test Laboratory:

7layers GmbH
Borsigstrasse 11
40880 Ratingen
Germany



Note:

The following test results relate only to the devices specified in this document. This report shall not be reproduced in parts without the written approval of the test laboratory.

7layers GmbH
Borsigstraße 11
40880 Ratingen, Germany
T +49 (0) 2102 749 0
F +49 (0) 2102 749 350

Geschäftsführer/
Managing Directors:
Frank Spiller
Bernhard Retka
Alexandre Norré-Oudard

Registergericht/registered:
Düsseldorf HRB 75554
USt-Id.-Nr./VAT-No. DE203159652
Steuer-Nr./TAX-No. 147/5869/0385

*a Bureau Veritas
Group Company*

www.7layers.com

Table of Contents

1.1	Applied Standards	3
1.2	Measurement Summary / Signatures	4
2	Administrative Data	8
2.1	Testing Laboratory	8
2.2	Project Data	8
2.3	Applicant Data	8
2.4	Manufacturer Data	8
3	Test object Data	9
3.1	General EUT Description	9
3.2	EUT Main components	9
3.3	Ancillary Equipment	10
3.4	Auxiliary Equipment	10
3.5	EUT Setups	10
3.6	Operating Modes	11
3.7	Product labelling	11
4	Test Results	12
4.1	Average Radiated Power [EIRP]	12
4.2	Peak to Average Ratio	18
4.3	Occupied Bandwidth	26
4.4	Conducted spurious emissions at antenna terminals	36
4.5	Out-of-band emission limits	41
4.6	Field strength of spurious radiation	47
5	Test Equipment	53
6	Antenna Factors, Cable Loss and Sample Calculations	56
6.1	LISN R&S ESH3-Z5 (150 kHz – 30 MHz)	56
6.2	Antenna R&S HFH2-Z2 (9 kHz – 30 MHz)	57
6.3	Antenna R&S HL562 (30 MHz – 1 GHz)	58
6.4	Antenna R&S HF907 (1 GHz – 18 GHz)	59
6.5	Antenna EMCO 3160-09 (18 GHz – 26.5 GHz)	60
6.6	Antenna EMCO 3160-10 (26.5 GHz – 40 GHz)	61
7	Measurement Uncertainties	62
8	Photo Report	62

Applied Standards and Test Summary

1.1 APPLIED STANDARDS

Type of Authorization

Certification for a SDARS terrestrial repeater.

Applicable FCC Rules

Prepared in accordance with the requirements of FCC Rules and Regulations as listed in 47 CFR Ch.1 Parts 2 and 25 (10/1/18 Edition). The following subparts are applicable to the results in this test report.

Part 2, Subpart J - Equipment Authorization Procedures, Certification

Part 25, Satellite Communications
Subpart C – Technical standards

§ 25.202 – Frequencies, frequency tolerance, and emission limits.

§ 25.214 – Technical requirements for space stations in the Satellite Digital Audio Radio Service and associated terrestrial repeaters

The tests were selected and performed with reference to:

- FCC Public Notice 935210 applying “Measurement guidance for industrial and non-consumer signal booster, repeater and amplifier devices” 935210 D05 v01r03, 2019-04-15.
- FCC Public Notice 971168 applying “Measurement guidance for certification of licensed digital transmitters” 971168 D01 v03r01, 2018-04-09
- ANSI C63.26: 2015

Summary Test Results:

The EUT complied with all performed tests as listed in chapter 1.3 Measurement Summary / Signatures.

1.2 MEASUREMENT SUMMARY / SIGNATURES

47 CFR CHAPTER I FCC PART 25 Subpart C **§2.1046, §25.214 (d) (1)**

Average Radiated Power [EIRP]

The measurement was performed according to ANSI C63.26, KDB 935210 D05 v01r02: 3.5

Final Result

OP-Mode	Setup	FCC	IC
Frequency Band, Direction, Input Power, Signal Type, No of Input signals			
Low [Sirius], RF downlink, 0.3 dB < AGC, AWGN, 2	S01_AA01	Passed	-
Low [Sirius], RF downlink, 0.3 dB < AGC, COFDM, 2	S01_AA01	Passed	-
Low [Sirius], RF downlink, 3 dB > AGC, AWGN, 2	S01_AA01	Passed	-
Low [Sirius], RF downlink, 3 dB > AGC, COFDM, 2	S01_AA01	Passed	-
High [XM], RF downlink, 0.3 dB < AGC, AWGN, 2	S01_AA01	Passed	-
High [XM], RF downlink, 0.3 dB < AGC, COFDM, 2	S01_AA01	Passed	-
High [XM], RF downlink, 3 dB > AGC, AWGN, 2	S01_AA01	Passed	-
High [XM], RF downlink, 3 dB > AGC, COFDM, 2	S01_AA01	Passed	-
Low [Sirius], RF downlink, 0.3 dB < AGC, AWGN, 1	S01_AA01	Passed	-
Low [Sirius], RF downlink, 3 dB > AGC, AWGN, 1	S01_AA01	Passed	-
High [XM], RF downlink, 0.3 dB < AGC, AWGN, 1	S01_AA01	Passed	-
High [XM], RF downlink, 3 dB > AGC, AWGN, 1	S01_AA01	Passed	-

47 CFR CHAPTER I FCC PART 25 Subpart C **§25.214 (d) (1)**

Peak to Average Ratio [PAPR]

The measurement was performed according to ANSI C63.26

Final Result

OP-Mode	Setup	FCC	IC
Frequency Band, Direction, Input Power, Signal Type, No of Input signals			
Low [Sirius], RF downlink, 0.3 dB < AGC, AWGN, 2	S01_AA01	Passed	-
Low [Sirius], RF downlink, 0.3 dB < AGC, COFDM, 2	S01_AA01	Passed	-
Low [Sirius], RF downlink, 3 dB > AGC, AWGN, 2	S01_AA01	Passed	-
Low [Sirius], RF downlink, 3 dB > AGC, COFDM, 2	S01_AA01	Passed	-
High [XM], RF downlink, 0.3 dB < AGC, AWGN, 2	S01_AA01	Passed	-
High [XM], RF downlink, 0.3 dB < AGC, COFDM, 2	S01_AA01	Passed	-
High [XM], RF downlink, 3 dB > AGC, AWGN, 2	S01_AA01	Passed	-
High [XM], RF downlink, 3 dB > AGC, COFDM, 2	S01_AA01	Passed	-
Low [Sirius], RF downlink, 0.3 dB < AGC, AWGN, 1	S01_AA01	Passed	-
Low [Sirius], RF downlink, 3 dB > AGC, AWGN, 1	S01_AA01	Passed	-
High [XM], RF downlink, 0.3 dB < AGC, AWGN, 1	S01_AA01	Passed	-
High [XM], RF downlink, 3 dB > AGC, AWGN, 1	S01_AA01	Passed	-

47 CFR CHAPTER I FCC PART 25 Subpart C §2.1049

Occupied Bandwidth / Input-versus-output Spectrum

The measurement was performed according to ANSI C63.26, KDB 935210 D05 v01r02: 3.4

Final Result

OP-Mode	Setup	FCC	IC
Frequency Band, Direction, Input Power, Signal Type			
Low [Sirius], RF downlink, 0.3 dB < AGC, AWGN	S01_AA01	Passed	-
Low [Sirius], RF downlink, 0.3 dB < AGC, COFDM	S01_AA01	Passed	-
Low [Sirius], RF downlink, 3 dB > AGC, AWGN	S01_AA01	Passed	-
Low [Sirius], RF downlink, 3 dB > AGC, COFDM	S01_AA01	Passed	-
High [XM], RF downlink, 0.3 dB < AGC, AWGN	S01_AA01	Passed	-
High [XM], RF downlink, 0.3 dB < AGC, COFDM	S01_AA01	Passed	-
High [XM], RF downlink, 3 dB > AGC, AWGN	S01_AA01	Passed	-
High [XM], RF downlink, 3 dB > AGC, COFDM	S01_AA01	Passed	-

47 CFR CHAPTER I FCC PART 25 Subpart C §2.1051, §25.202 (h) (1)

Conducted spurious emissions at antenna terminals

The measurement was performed according to ANSI C63.26

Final Result

OP-Mode	Setup	FCC	IC
Frequency Band, Test Frequency, Direction, Signal Type			
Low [Sirius], mid, RF downlink, AWGN	S01_AA01	Passed	-
Low [Sirius], mid, RF downlink, COFDM	S01_AA01	Passed	-
High [XM], mid, RF downlink, AWGN	S01_AA01	Passed	-
High [XM], mid, RF downlink, COFDM	S01_AA01	Passed	-

47 CFR CHAPTER I FCC PART 25 Subpart C §2.1051, §25.202 (h) (1)

Out-of-band emission limits

The measurement was performed according to ANSI C63.26

Final Result

OP-Mode	Setup	FCC	IC
Frequency Band, Test Frequency, Band Edge, Direction, Input Power, Signal Type			
Low [Sirius], mid, Lower, RF downlink, 0.3 dB < AGC, AWGN	S01_AA01	Passed	-
Low [Sirius], mid, Lower, RF downlink, 0.3 dB < AGC, COFDM	S01_AA01	Passed	-
Low [Sirius], mid, Lower, RF downlink, 3 dB > AGC, AWGN	S01_AA01	Passed	-
Low [Sirius], mid, Lower, RF downlink, 3 dB > AGC, COFDM	S01_AA01	Passed	-
High [XM], mid, Lower, RF downlink, 0.3 dB < AGC, AWGN	S01_AA01	Passed	-
High [XM], mid, Lower, RF downlink, 0.3 dB < AGC, COFDM	S01_AA01	Passed	-
High [XM], mid, Lower, RF downlink, 3 dB > AGC, AWGN	S01_AA01	Passed	-
High [XM], mid, Lower, RF downlink, 3 dB > AGC, COFDM	S01_AA01	Passed	-

47 CFR CHAPTER I FCC PART 25 Subpart C

§2.1053, §25.202 (h) (1)

Field strength of spurious radiation

The measurement was performed according to ANSI C63.26

Final Result

OP-Mode

Frequency Band, Test Frequency, Direction, Signal Type

Low [Sirius], mid, RF downlink, AWGN

Low [Sirius], mid, RF downlink, COFDM

High [XM], mid, RF downlink, AWGN

High [XM], mid, RF downlink, COFDM

Setup

S01_AA01

S01_AA01

S01_AA01

S01_AA01

FCC

Passed

Passed

Passed

Passed

IC

-

-

-

-

N/A: Not applicable

N/P: Not performed

The test case frequency stability [25.202 (d)] was not performed, since the EUT is not equipped with signal processing capabilities.

Report version control			
Version	Release date	Change Description	Version validity
initial	2019-05-14	--	valid



(responsible for accreditation scope)
Dipl.-Ing. Marco Kullik

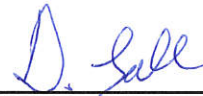

(responsible for testing and report)
Dipl.-Ing. Daniel Gall



7 layers GmbH, Borsigstr. 11
40880 Ratingen, Germany
Phone +49 (0)2102 749 0

2 ADMINISTRATIVE DATA

2.1 TESTING LABORATORY

Company Name: 7layers GmbH

Address: Borsigstr. 11
40880 Ratingen
Germany

The test facility is also accredited by the following accreditation organisation:

Laboratory accreditation no: DAkKS D-PL-12140-01-00

FCC Designation Number: DE0015

FCC Test Firm Registration: 929146

ISED CAB Identifier DE0007; ISED#: 3699A

Responsible for accreditation scope: Dipl.-Ing. Marco Kullik

Report Template Version: 2019-05-08

2.2 PROJECT DATA

Responsible for testing and report: Dipl.-Ing. Daniel Gall

Employees who performed the tests: documented internally at 7Layers

Date of Report: 2019-05-14

Testing Period: 2019-04-02 to 2019-04-24

2.3 APPLICANT DATA

Company Name: Commscope
Andrew Wireless Systems GmbH

Address: Industriering 10
86675 Buchdorf
Germany

Contact Person: Mr. Frank Futter

2.4 MANUFACTURER DATA

Company Name: please see applicant data

Address:

Contact Person:

3 TEST OBJECT DATA

3.1 GENERAL EUT DESCRIPTION

Kind of Device product description	SDARS Terrestrial Repeater
Product name	SDARS Remote Optical System
Type	ION-M23 SDARS 1-Sector Passive
Declared EUT data by the supplier	
General Product Description	The EUT is a SDARS terrestrial repeater supporting the following range: 2324 – 2341.5 MHz A RF operation is only supported for the downlink.
Booster Type	SDARS Terrestrial Repeater
Voltage Type	AC & DC
Voltage Level	AC: 100 – 240 V, 50 – 60 Hz DC: 48 – 60 V
Maximum Output Donor Port [Uplink]	-
Maximum Output Server Port [Downlink]	37.5 dBm [1 carrier] 34.5 dBm [2 carriers]
Maximum Gain [Uplink]	-
Maximum Gain [Downlink]	56.5 dB

The main components of the EUT are listed and described in chapter 3.2 EUT Main components.

3.2 EUT MAIN COMPONENTS

Sample Name	Sample Code	Description
aa01	DE1277010aa01	FCC sample
Sample Parameter	Value	
Serial Number	SN: 11	
HW Version	ION-M23 SDARS 1-Sector Passive (ID: 7760774-0002)	
SW Version	SW V5.28.0.4 RCM161RU (ID: 7162793-28)	
Comment	-	

NOTE: The short description is used to simplify the identification of the EUT in this test report.

3.3 ANCILLARY EQUIPMENT

For the purposes of this test report, ancillary equipment is defined as equipment which is used in conjunction with the EUT to provide operational and control features to the EUT. It is necessary to configure the system in a typical fashion, as a customer would normally use it. But nevertheless Ancillary Equipment can influence the test results.

Device	Details (Manufacturer, Type Model, OUT Code)	Description
-	-	-

3.4 AUXILIARY EQUIPMENT

For the purposes of this test report, auxiliary equipment is defined as equipment which is used temporarily to enable operational and control features especially used for the tests of the EUT which is not used during normal operation or equipment that is used during the tests in combination with the EUT but is not subject of this test report. It is necessary to configure the system in a typical fashion, as a customer would normally use it. But nevertheless Auxiliary Equipment can influence the test results.

Device	Details (Manufacturer, HW, SW, S/N)	Description
-	--	-

3.5 EUT SETUPS

This chapter describes the combination of EUTs and equipment used for testing. The rationale for selecting the EUTs, ancillary and auxiliary equipment and interconnecting cables, is to test a representative configuration meeting the requirements of the referenced standards.

Setup	Combination of EUTs	Description and Rationale
S01_AA01	aa01	Setup for all tests

3.6 OPERATING MODES

This chapter describes the operating modes of the EUTs used for testing.

3.6.1 TEST CHANNELS

Band	Direction	Lower Frequency Band Edge [MHz]	Upper Frequency Band Edge [MHz]	Center Frequency [MHz]	Port
Low (Sirius)	downlink	2320.00	2332.50	2326.25	Donor
High (XM)	downlink	2332.50	2345.00	2338.75	Donor

3.6.2 AUTOMATIC GAIN CONTROL LEVELS

AGC Levels (Two simultaneous input signals)							
Band	Direction	Signal Type	AGC Start Pin [dBm]	AGC Start Pin -0.3 dB [dBm]	AGC Start Pin +3 dB [dBm]	Frequency [MHz]	Frequency
Low / High	downlink	COFDM	3.1	2.8	6.1	2326.25	Center
Low / High	downlink	AWGN	2.4	2.1	5.4	2338.75	

AGC Levels (One input signal)							
Band	Direction	Signal Type	AGC Start Pin [dBm]	AGC Start Pin -0.3 dB [dBm]	AGC Start Pin +3 dB [dBm]	Frequency [MHz]	Frequency
Low	downlink	AWGN	2.8	2.5	5.8	2326.25	Center
High	downlink	AWGN	2.8	2.5	5.8	2338.75	

3.7 PRODUCT LABELLING

3.7.1 FCC ID LABEL

Please refer to the documentation of the applicant.

3.7.2 LOCATION OF THE LABEL ON THE EUT

Please refer to the documentation of the applicant.

4 TEST RESULTS

4.1 AVERAGE RADIATED POWER [EIRP]

Standard FCC Part 25, §25.214

The test was performed according to:
ANSI C63.26, KDB 935210 D05 v01r02: 3.5

4.1.1 TEST DESCRIPTION

This test case is intended to demonstrate compliance to the signal booster power and gain limits and requirements for industrial signal boosters.

The EUT was connected to the test setup according to the following diagram:

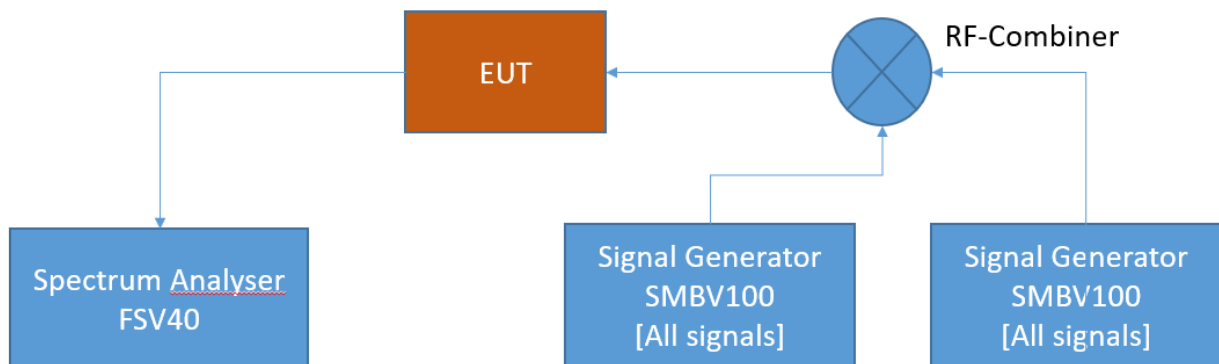

FCC Part 25 Satellite signal booster – Test Setup; RF Output Power

The attenuation of the measuring and stimulus path are known for each measured frequency and are considered.

The Spectrum Analyzer settings can be directly found in the measurement diagrams.

4.1.2 TEST REQUIREMENTS / LIMITS

Part 25; Satellite Communications

Subpart C – Technical standards

§25.214

d) *Power limit for SDARS terrestrial repeaters.* (1) SDARS terrestrial repeaters must be operated at a power level less than or equal to 12-kW average EIRP, with a maximum peak-to-average power ratio of 13 dB.

4.1.3 TEST PROTOCOL

Low [Sirius] / High [XM], downlink (Two simultaneous input signals)					
Signal Type	Input Power	Frequency [MHz]	Maximum Average Output Power [dBm]	Limit Average Output Power EIRP [dBm]	Margin to Limit [dB]
AWGN	0.3 dB < AGC	2326.25 / 2338.75	37.3	70.8	33.5
AWGN	3 dB > AGC	2326.25 / 2338.75	38.0	70.8	32.8
COFDM	0.3 dB < AGC	2326.25 / 2338.75	37.1	70.8	33.7
COFDM	3 dB > AGC	2326.25 / 2338.75	37.6	70.8	33.2

Low [XM] / High [XM], downlink (one input signal)					
Signal Type	Input Power	Frequency [MHz]	Maximum Average Output Power [dBm]	Limit Average Output Power EIRP [dBm]	Margin to Limit [dB]
AWGN	0.3 dB < AGC	2326.25	37.4	70.8	33.4
AWGN	3 dB > AGC	2326.25	37.8	70.8	33.0
AWGN	0.3 dB < AGC	2338.75	36.5	70.8	34.3
AWGN	3 dB > AGC	2338.75	37.0	70.8	33.8

The "Maximum Average Output Power" is the conducted power value. Due to the fact, that the limit is an EIRP limit, the maximum antenna gain value is **32.8 dBi**

Please note, that depending on SAR limits the maximum antenna gain may cannot be exploited.

Remark: Please see next sub-clause for the measurement plot.

4.1.4 MEASUREMENT PLOT (SHOWING THE HIGHEST VALUE, "WORST CASE")

Frequency Band = Band Low/High, Direction = RF downlink, Input Power = 3 dB > AGC, Signal Type = AWGN, 2 input signals (S01_AA01)

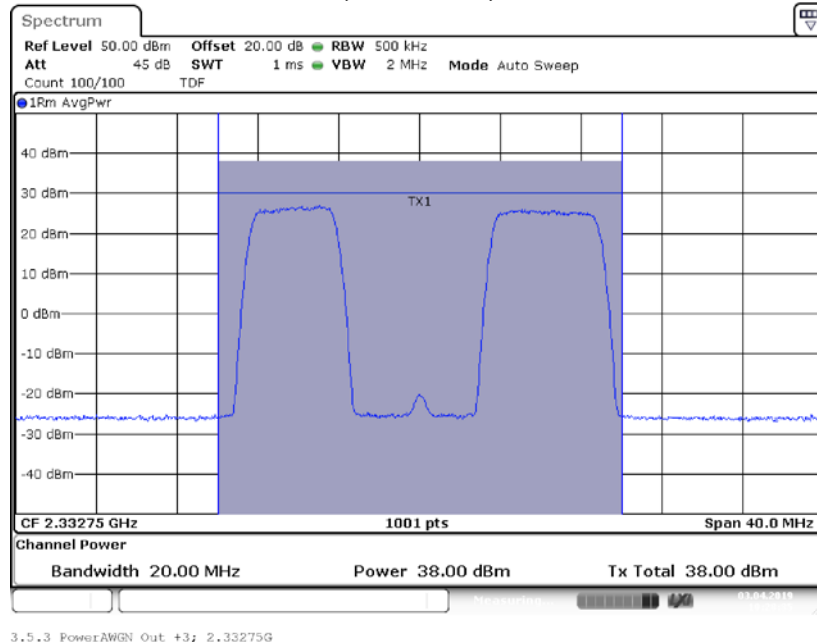

Frequency Band = Band Low/High, Direction = RF downlink, Input Power = 3 dB > AGC, Signal Type = COFDM, 2 input signals (S01_AA01)

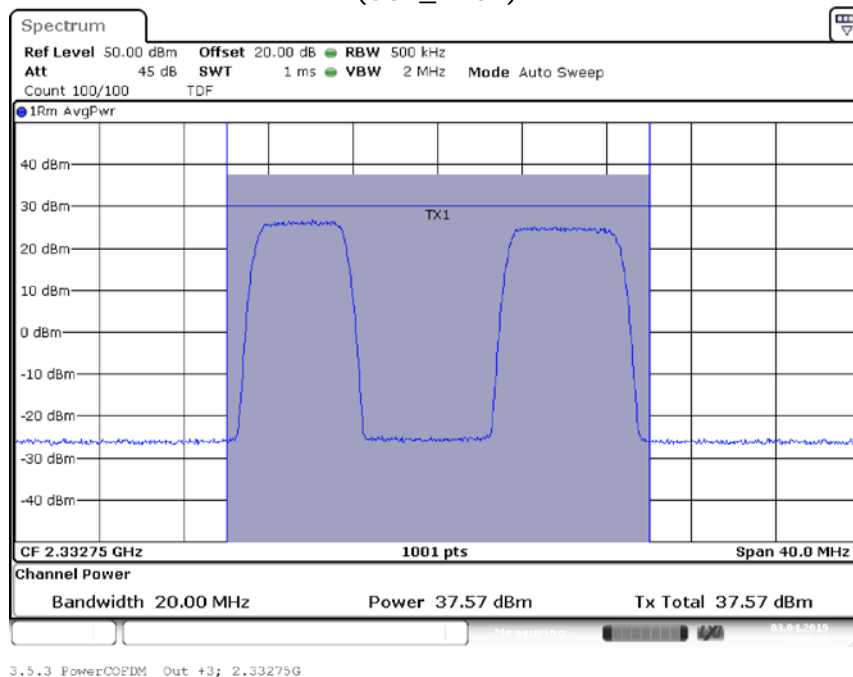

Frequency Band = Band Low/High, Direction = RF downlink, Input Power = 0.3 dB < AGC,
 Signal Type = AWGN, 2 input signals
 (S01_AA01)

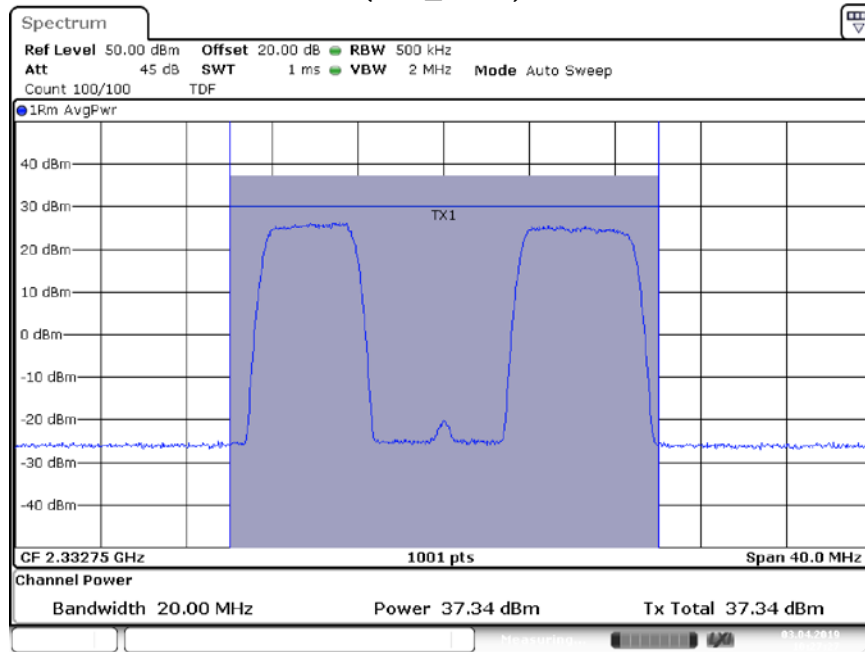

3.5.3 PowerAWGN Out -0.3; 2.33275G

Frequency Band = Band Low/High, Direction = RF downlink, Input Power = 0.3 dB < AGC,
 Signal Type = COFDM, 2 input signals
 (S01_AA01)

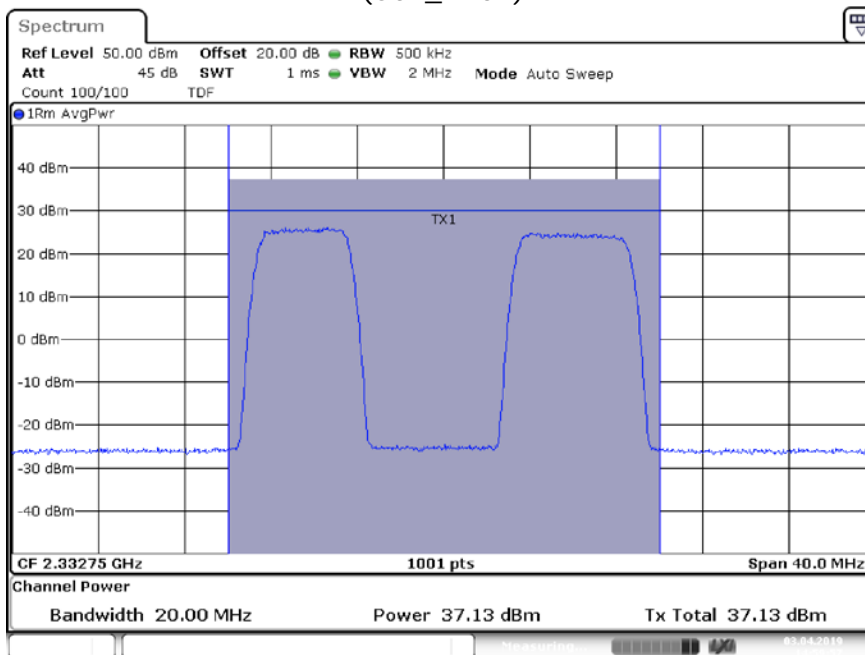

3.5.3 PowerCOFDM Out -0.3; 2.33275G

Frequency Band = Band Low, Direction = RF downlink, Input Power = 3 dB > AGC, Signal Type = AWGN, 1 input signal (S01_AA01)

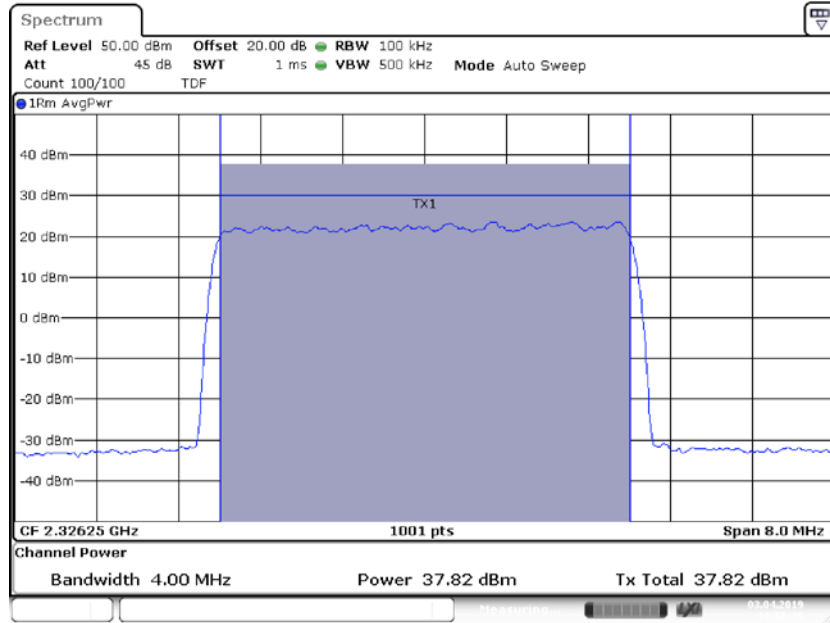

3.5.3 PowerAWGN Out +3; 2.32625G

Frequency Band = Band High, Direction = RF downlink, Input Power = 3 dB > AGC, Signal Type = AWGN, 1 input signal (S01_AA01)

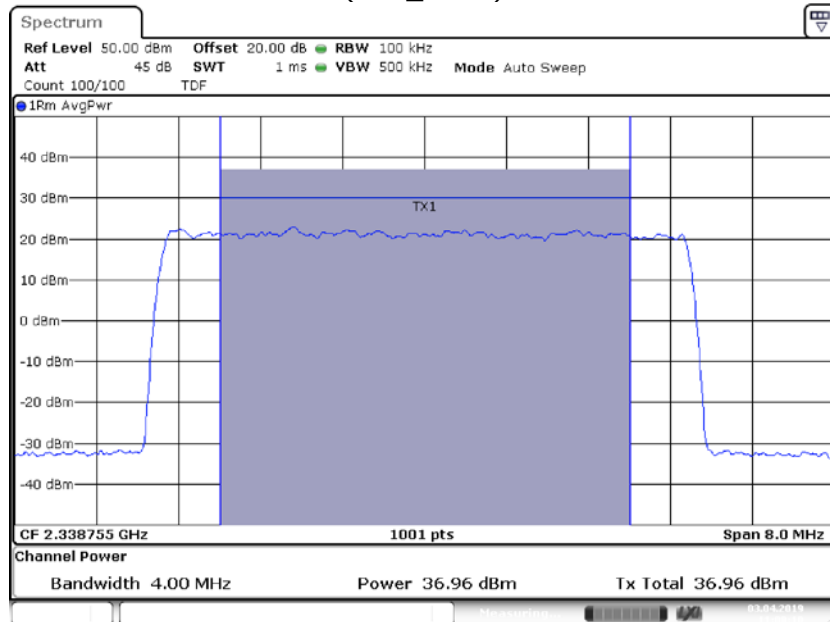

3.5.3 PowerAWGN Out +3; 2.33875G

Frequency Band = Band Low, Direction = RF downlink, Input Power = 0.3 dB < AGC, Signal Type = AWGN, 1 input signal (S01_AA01)

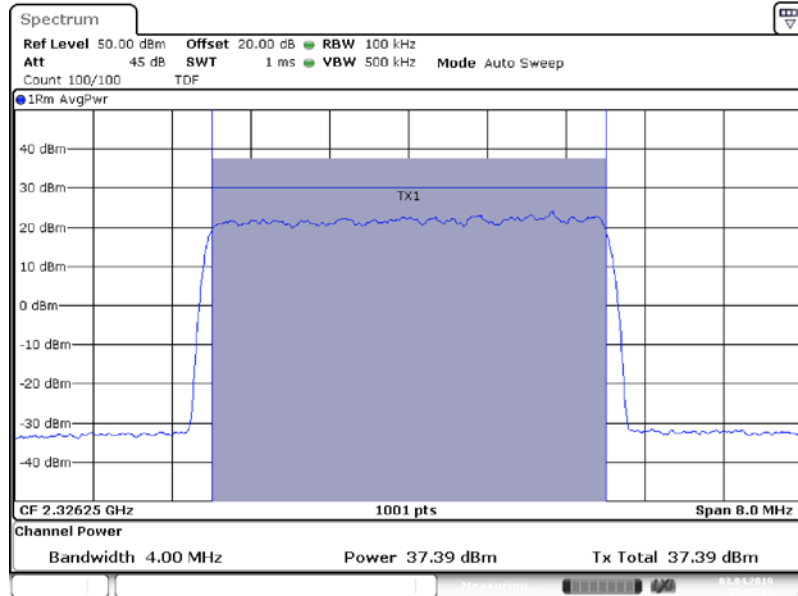

3.5.3 PowerAWGN Out: -0.3; 2.32625G

Frequency Band = Band = High, Direction = RF downlink, Input Power = 0.3 dB < AGC, Signal Type = AWGN, 1 input signal (S01_AA01)

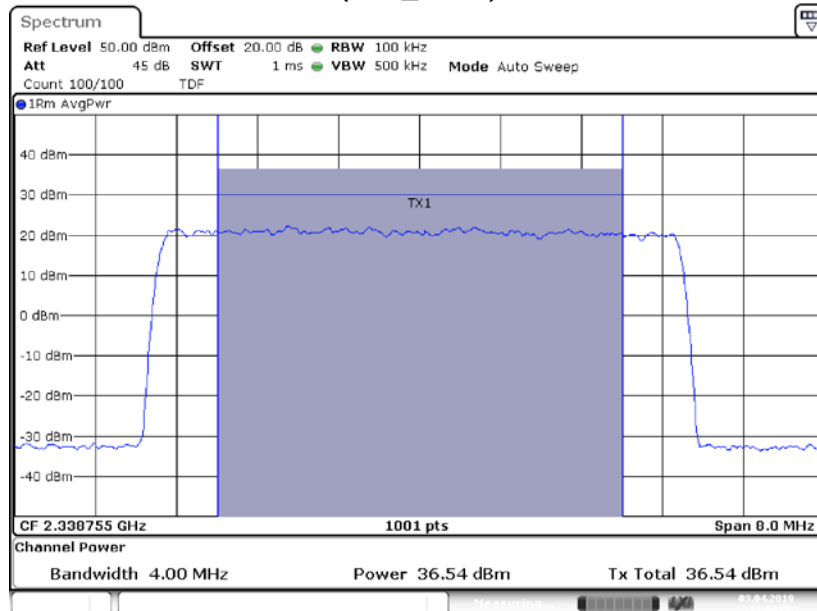

3.5.3 PowerAWGN Out: -0.3; 2.33876G

4.1.5 TEST EQUIPMENT USED

- FCC Conducted Base Station / Repeater

4.2 PEAK TO AVERAGE RATIO

Standard FCC Part 25, §25.214

The test was performed according to:
ANSI C63.26, KDB 935210 D05 v01r02: 3.5

4.2.1 TEST DESCRIPTION

This test case is intended to demonstrate compliance to the signal booster power and gain limits and requirements for industrial signal boosters.

The EUT was connected to the test setup according to the following diagram:

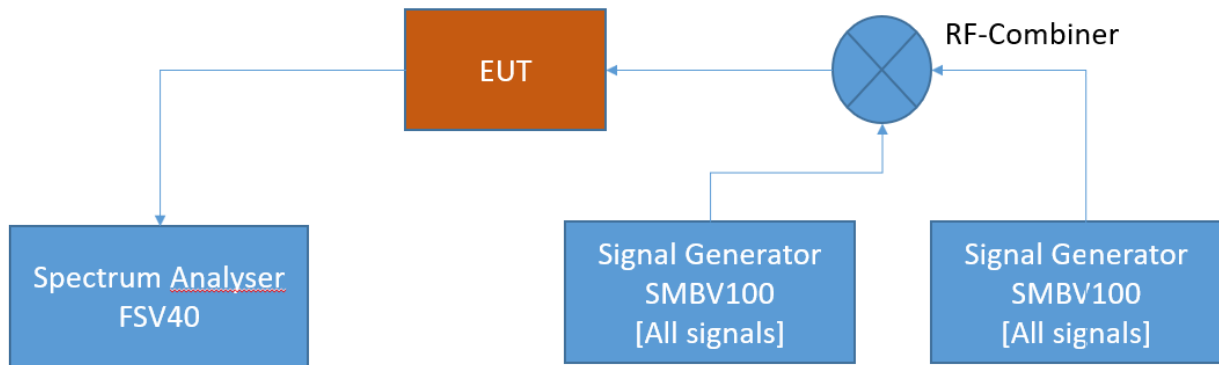

FCC Part 25 Satellite signal booster – Test Setup; RF Output Power

The attenuation of the measuring and stimulus path are known for each measured frequency and are considered.

The Spectrum Analyzer settings can be directly found in the measurement diagrams.

4.2.2 TEST REQUIREMENTS / LIMITS

Part 25; Satellite Communications

Subpart C – Technical standards

§25.214

d) *Power limit for SDARS terrestrial repeaters.* (1) SDARS terrestrial repeaters must be operated at a power level less than or equal to 12-kW average EIRP, with a maximum peak-to-average power ratio of 13 dB.

4.2.3 TEST PROTOCOL

Low [Sirius], downlink, (Two simultaneous input signals)						
Signal Type	Input Power	Frequency [MHz]	Input Power [dBm]	PAPR [dB]	Limit PAPR [dB]	Margin to Limit [dB]
AWGN	0.3 dB < AGC	2326.25	2.1	8.4	13.0	4.6
AWGN	3 dB > AGC	2326.25	5.4	8.4	13.0	4.6
COFDM	0.3 dB < AGC	2326.25	2.8	8.3	13.0	4.7
COFDM	3 dB > AGC	2326.25	6.1	8.4	13.0	4.6

High [XM], downlink (Two simultaneous input signals)						
Signal Type	Input Power	Frequency [MHz]	Input Power [dBm]	PAPR [dB]	Limit PAPR [dB]	Margin to Limit [dB]
AWGN	0.3 dB < AGC	2338.75	2.1	8.5	13.0	4.5
AWGN	3 dB > AGC	2338.75	5.4	8.5	13.0	4.5
COFDM	0.3 dB < AGC	2338.75	2.8	8.5	13.0	4.5
COFDM	3 dB > AGC	2338.75	6.1	8.7	13.0	4.3

Low [Sirius], downlink, (One input signal)						
Signal Type	Input Power	Frequency [MHz]	Input Power [dBm]	PAPR [dB]	Limit PAPR [dB]	Margin to Limit [dB]
AWGN	0.3 dB < AGC	2326.25	2.5	8.4	13.0	4.6
AWGN	3 dB > AGC	2326.25	5.8	8.4	13.0	4.6

High [XM], downlink (One input signal)						
Signal Type	Input Power	Frequency [MHz]	Input Power [dBm]	PAPR [dB]	Limit PAPR [dB]	Margin to Limit [dB]
AWGN	0.3 dB < AGC	2338.75	2.5	8.5	13.0	4.5
AWGN	3 dB > AGC	2338.75	5.8	8.6	13.0	4.4

Remark: Please see next sub-clause for the measurement plot.

4.2.4 MEASUREMENT PLOT (SHOWING THE HIGHEST VALUE, "WORST CASE")

Frequency Band = Low [Sirius], Direction = RF downlink, Input Power = 3 dB > AGC, Signal Type = AWGN, 2 input signals (S01_AA01)

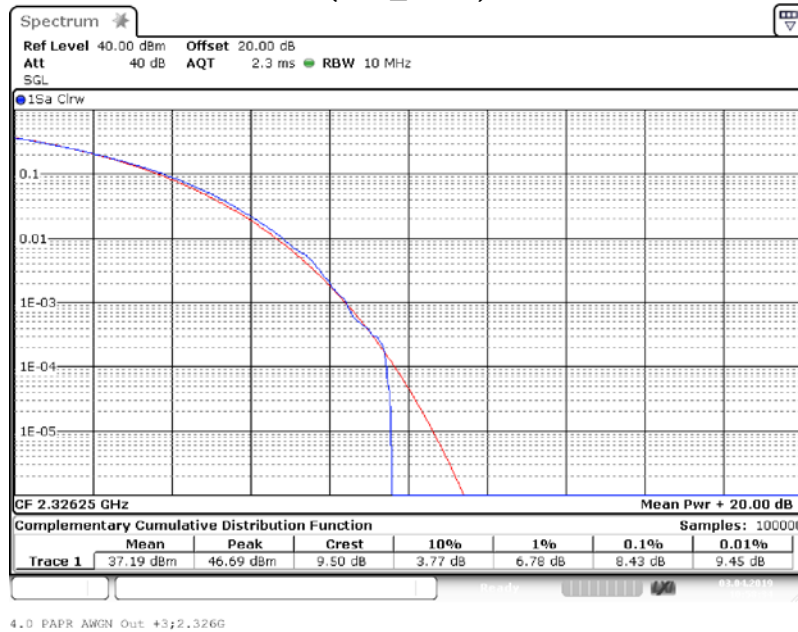

Frequency Band = Low [Sirius], Direction = RF downlink, , Input Power = 3 dB > AGC, Signal Type = COFDM, 2 input signals (S01_AA01)

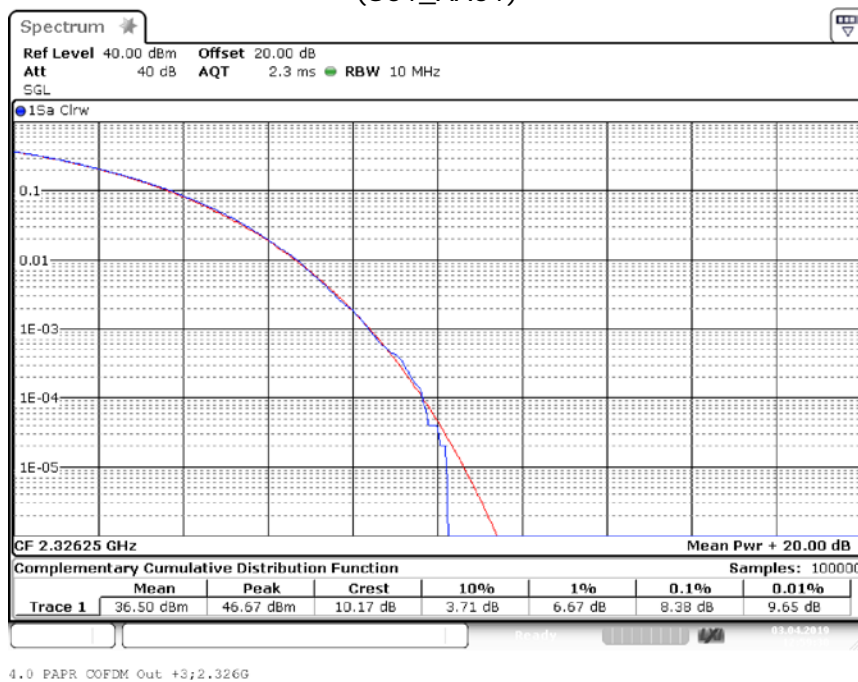

Frequency Band = Low [Sirius], Direction = RF downlink, Input Power = 0.3 dB < AGC, Signal Type = AWGN, 2 input signals (S01_AA01)

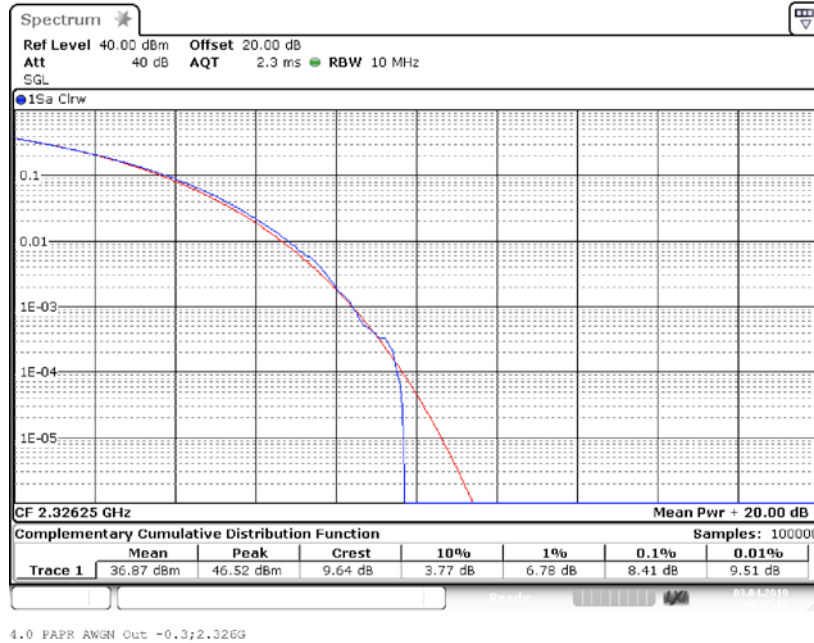

Frequency Band = Low [Sirius], Direction = RF downlink, Input Power = 0.3 dB < AGC, Signal Type = COFDM, 2 input signals (S01_AA01)

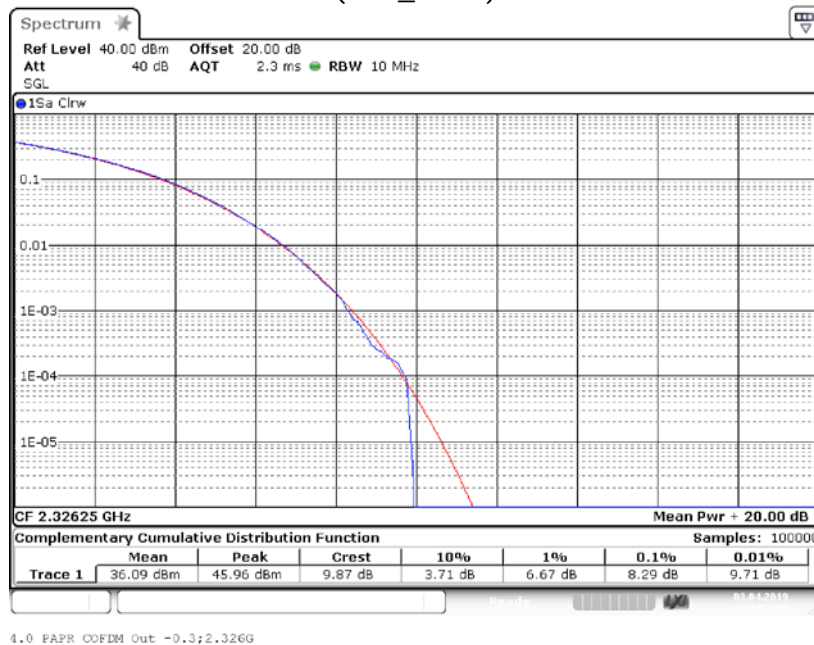

Frequency Band = High [XM], Direction = RF downlink, Input Power = 3 dB > AGC, Signal Type = AWGN, 2 input signals (S01_AA01)

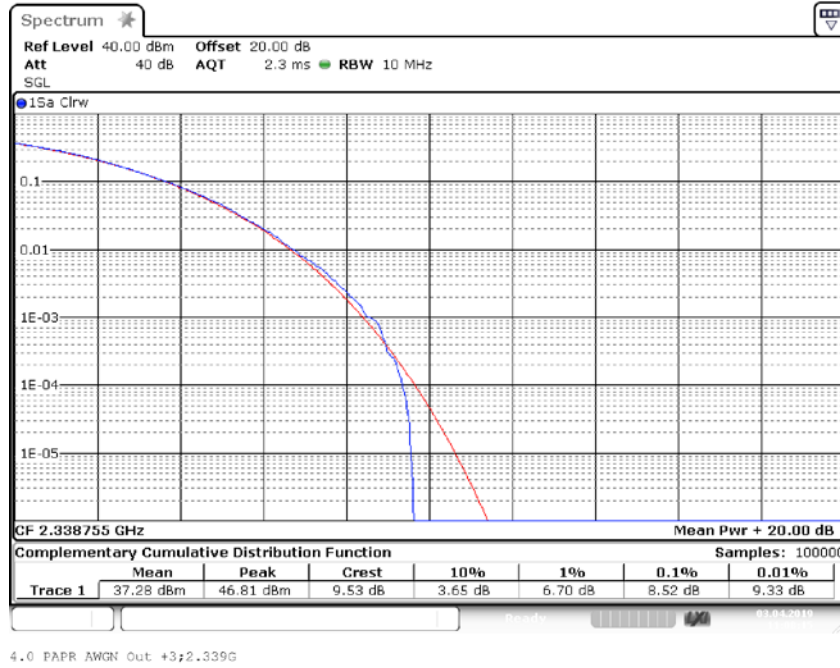

Frequency Band = High [XM], Direction = RF downlink, , Input Power = 3 dB > AGC, Signal Type = COFDM, 2 input signals (S01_AA01)

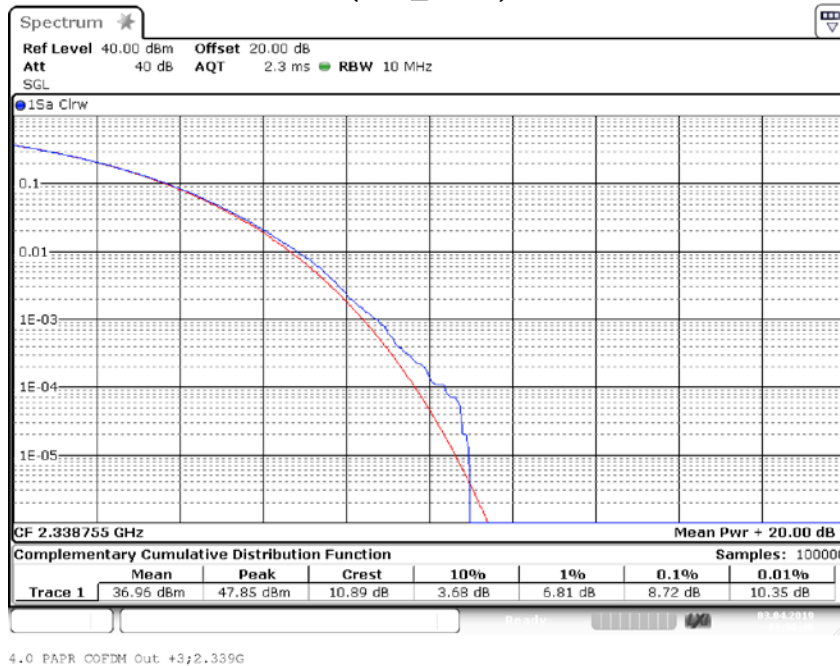

Frequency Band = High [XM], Direction = RF downlink, Input Power = 0.3 dB < AGC, Signal Type = AWGN, 2 input signals (S01_AA01)

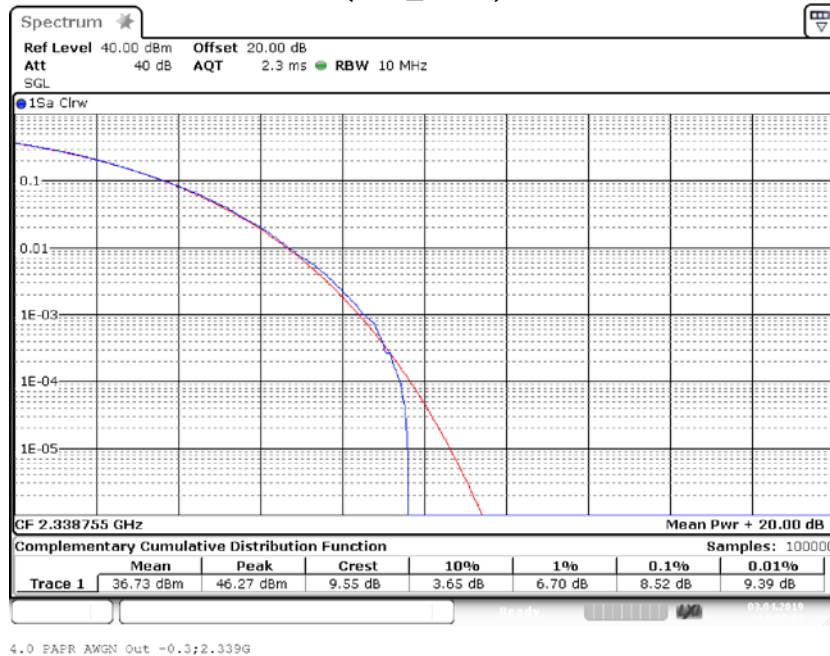

Frequency Band = High [XM], Direction = RF downlink, Input Power = 0.3 dB < AGC, Signal Type = COFDM, 2 input signals (S01_AA01)

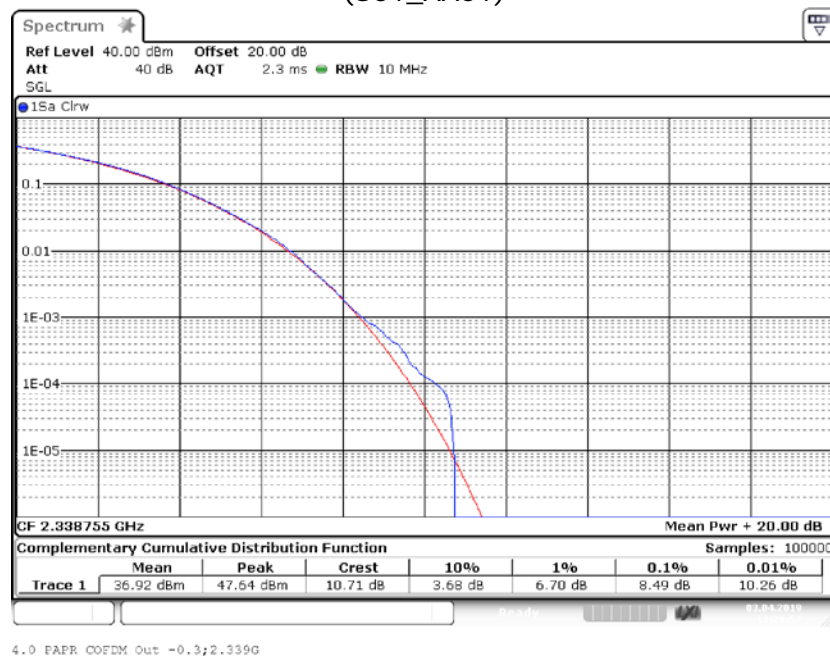

Frequency Band = Low [Sirius], Direction = RF downlink, Input Power = 0.3 dB < AGC, Signal Type = AWGN, 1 input signal (S01_AA01)

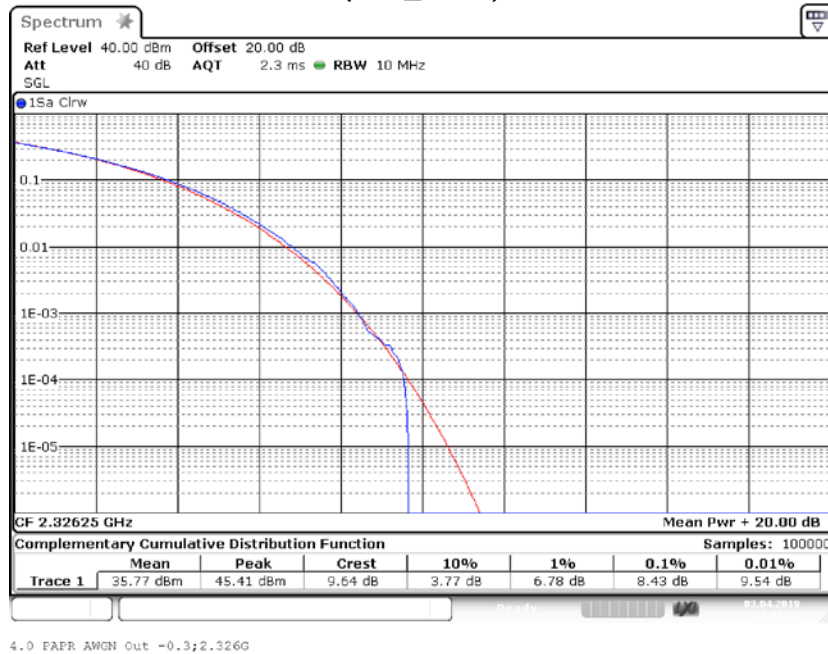

Frequency Band = High [XM], Direction = RF downlink, Input Power = 0.3 dB < AGC, Signal Type = AWGN, 1 input signal (S01_AA01)

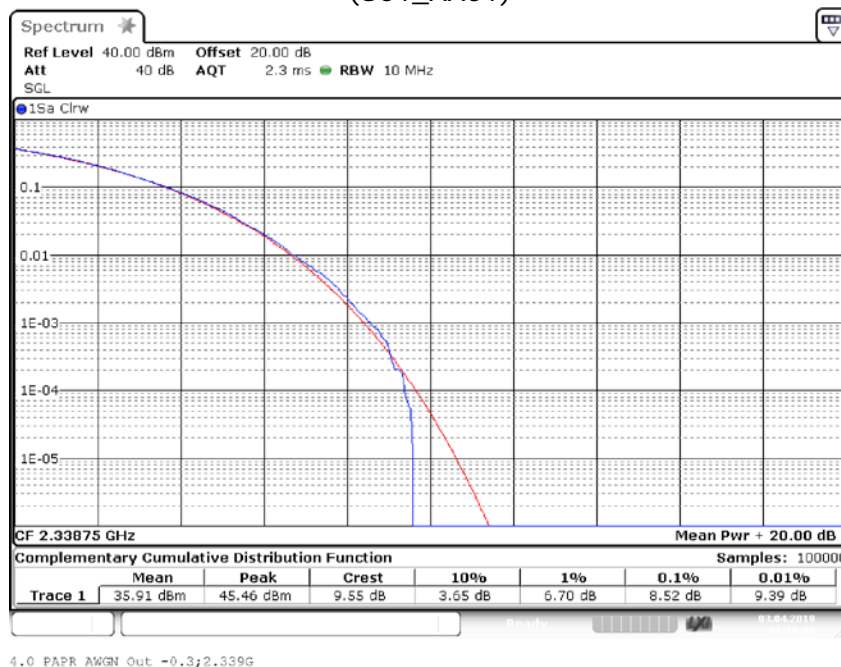

Frequency Band = Low [Sirius], Direction = RF downlink, Input Power = 3 dB > AGC, Signal Type = AWGN, 1 input signal (S01_AA01)

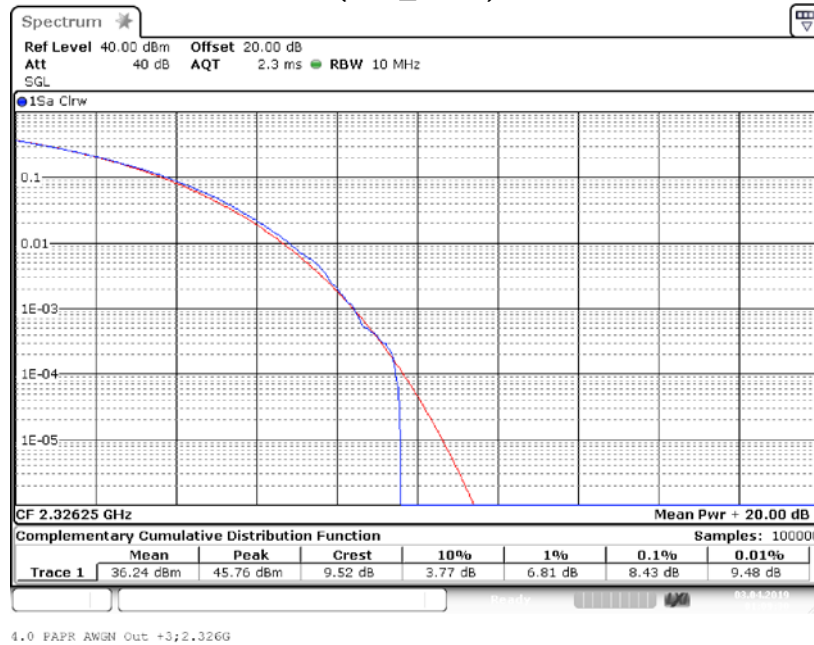

Frequency Band = High [XM], Direction = RF downlink, , Input Power = 3 dB > AGC, Signal Type = AWGN, 1 input signal (S01_AA01)

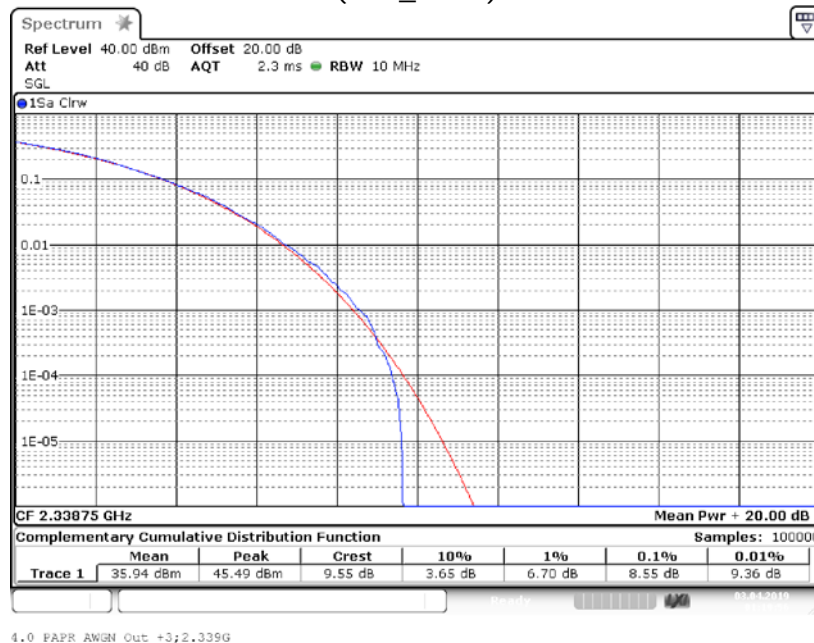

4.2.5 TEST EQUIPMENT USED

- FCC Conducted Base Station / Repeater

4.3 OCCUPIED BANDWIDTH

Standard FCC Part 2.1049; Occupied Bandwidth

The test was performed according to:
ANSI C63.26, KDB 935210 D05 v01r02: 3.4

4.3.1 TEST DESCRIPTION

This test case is intended to demonstrate compliance to the applicable conducted spurious emission limits per FCC §2.1049, RSS-GEN 6.4

The EUT was connected to the test setups according to the following diagram:

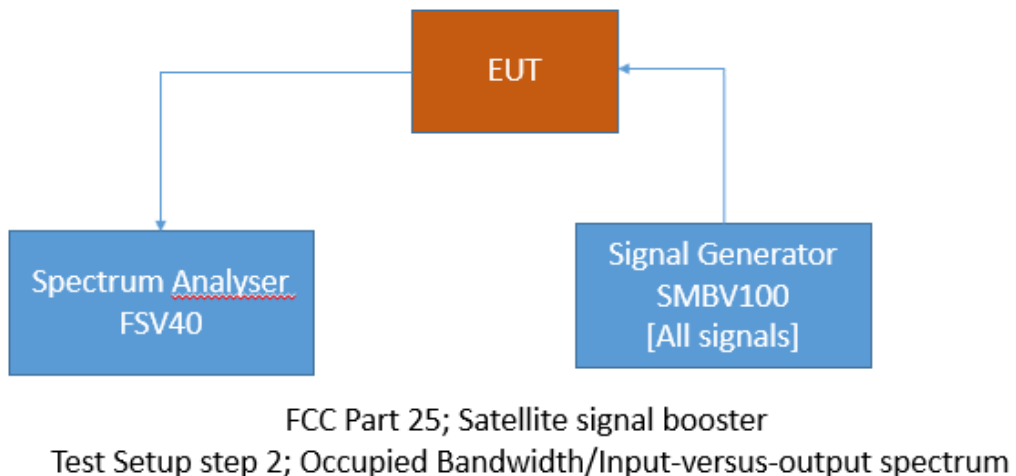
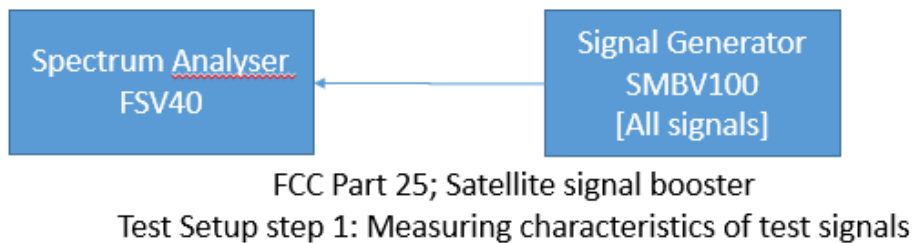

The attenuation of the measuring and stimulus path are known for each measured frequency and are considered.

The Spectrum Analyzer settings can be directly found in the measurement diagrams.

4.3.2 TEST REQUIREMENTS / LIMITS

FCC Part 2.1049; Occupied Bandwidth:

The occupied bandwidth, that is the frequency bandwidth such that, below its lower and above its upper frequency limits, the mean powers radiated are each equal to 0.3 percent of the total mean power radiated by a given emission shall be measured under the following conditions as applicable:

(h) Transmitters employing digital modulation techniques—when modulated by an input signal such that its amplitude and symbol rate represent the maximum rated conditions under which the equipment will be operated. The signal shall be applied through any filter networks, pseudo-random generators or other devices required in normal service. Additionally, the occupied bandwidth shall be shown for operation with any devices used for modifying the spectrum when such devices are optional at the discretion of the user.

(i) Transmitters designed for other types of modulation—when modulated by an appropriate signal of sufficient amplitude to be representative of the type of service in which used. A description of the input signal should be supplied.

4.3.3 TEST PROTOCOL

Low [Sirius], downlink					
Signal Type	Input Power	Signal Frequency [MHz]	Occupied Bandwidth SG [kHz]	Occupied Bandwidth Booster [kHz]	Delta Occupied Bandwidth [kHz]
AWGN	0.3 dB < AGC	2326.25	4014.8	4012.4	2.4
AWGN	3 dB > AGC	2326.25	4014.8	4012.4	2.4
COFDM	0.3 dB < AGC	2326.25	4067.6	4064.0	3.6
COFDM	3 dB > AGC	2326.25	4061.6	4059.2	2.4

High [XM], downlink					
Signal Type	Input Power	Signal Frequency [MHz]	Occupied Bandwidth SG [kHz]	Occupied Bandwidth Booster [kHz]	Delta Occupied Bandwidth [kHz]
AWGN	0.3 dB < AGC	2338.75	5047.0	5043.1	3.9
AWGN	3 dB > AGC	2338.75	5047.0	5043.1	3.9
COFDM	0.3 dB < AGC	2338.75	5086.7	5091.3	4.6
COFDM	3 dB > AGC	2338.75	5095.9	5086.7	9.2

Remark: Please see next sub-clause for the measurement plot.

4.3.4 MEASUREMENT PLOT (SHOWING THE HIGHEST VALUE, "WORST CASE")

Frequency Band = Low [Sirius], Direction = RF downlink, Input Power = 0.3 dB < AGC, Signal Type = AWGN (S01_AA01)

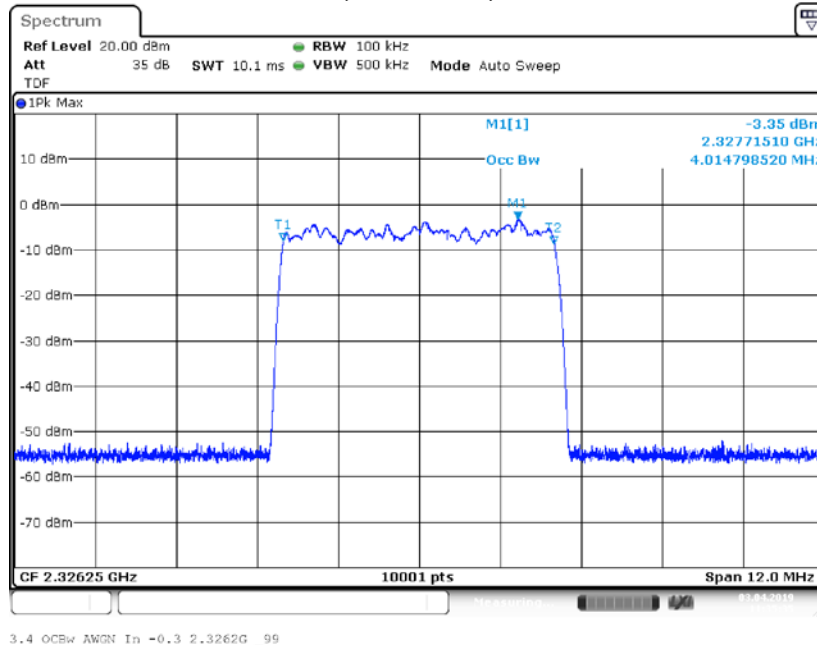

Input Signal

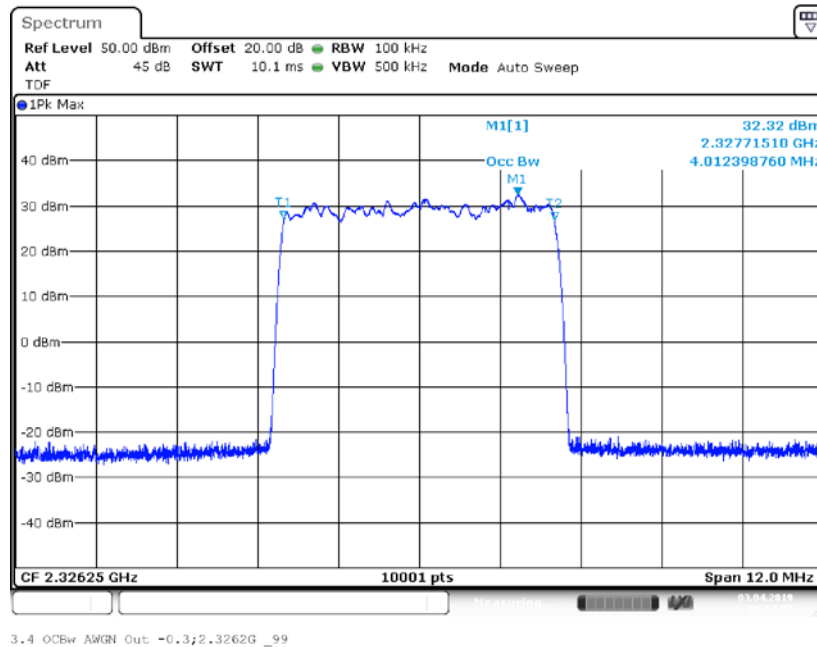

Output Signal

Frequency Band = Low [Sirius], Direction = RF downlink, Input Power = 0.3 dB < AGC, Signal Type = COFDM (S01_AA01)

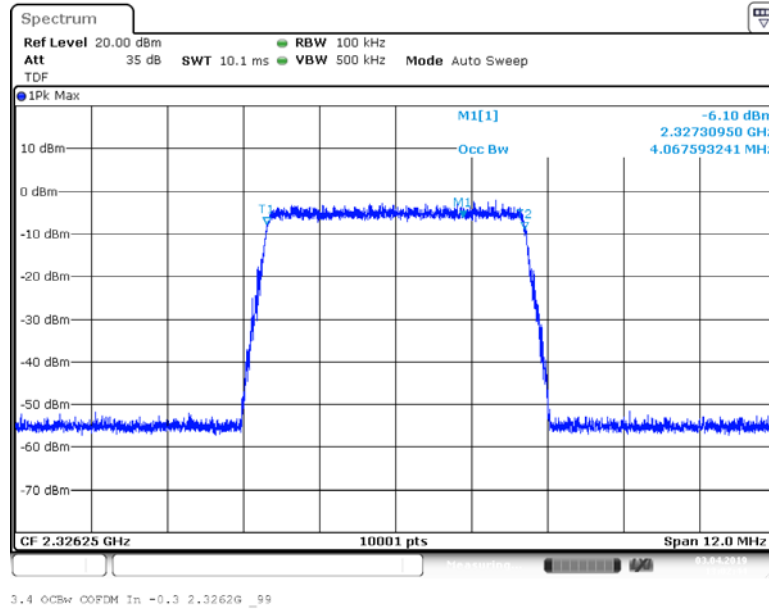

Input Signal

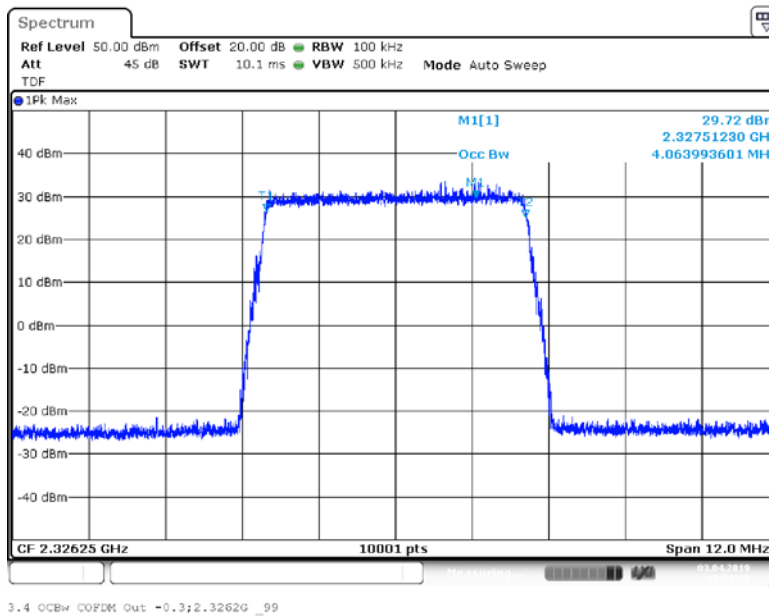

Output Signal

Frequency Band = Low [Sirius], Direction = RF downlink, Input Power = 3 dB > AGC, Signal Type = AWGN (S01_AA01)

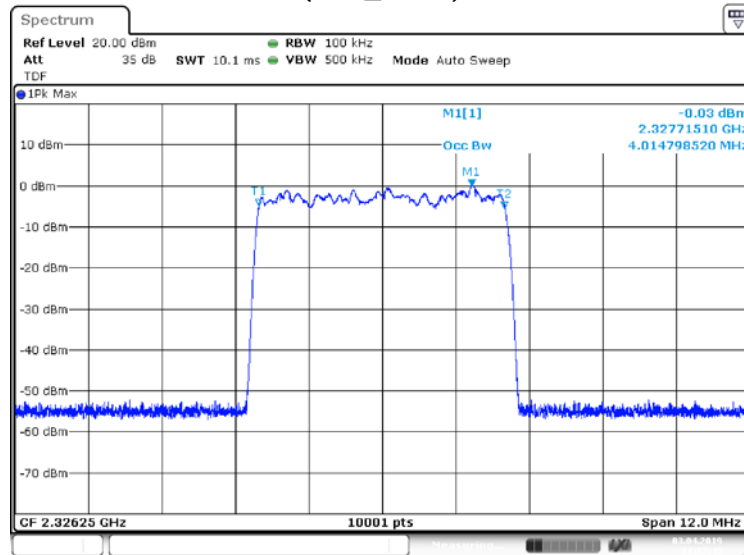

3.4 OCBw AWGN In +3 2.3262G _99

Input Signal

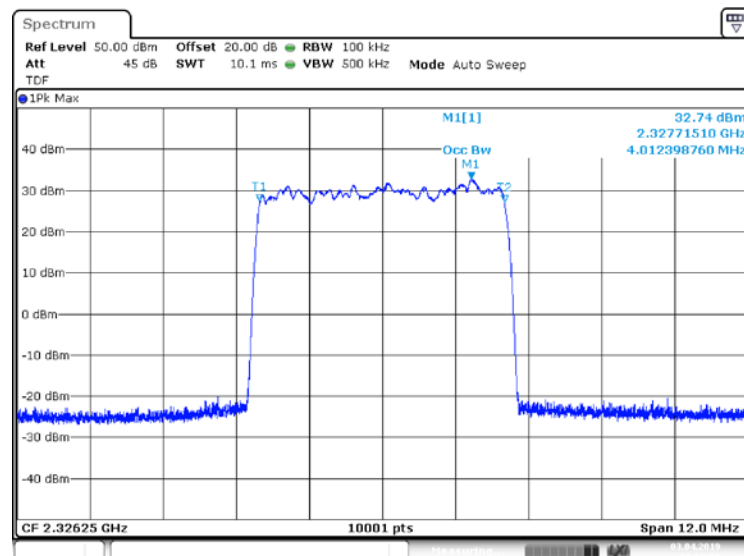

3.4 OCBw AWGN Out +3;2.3262G _99

Output Signal

Frequency Band = Low [Sirius], Direction = RF downlink, Input Power = 3 dB > AGC, Signal Type = COFDM (S01_AA01)

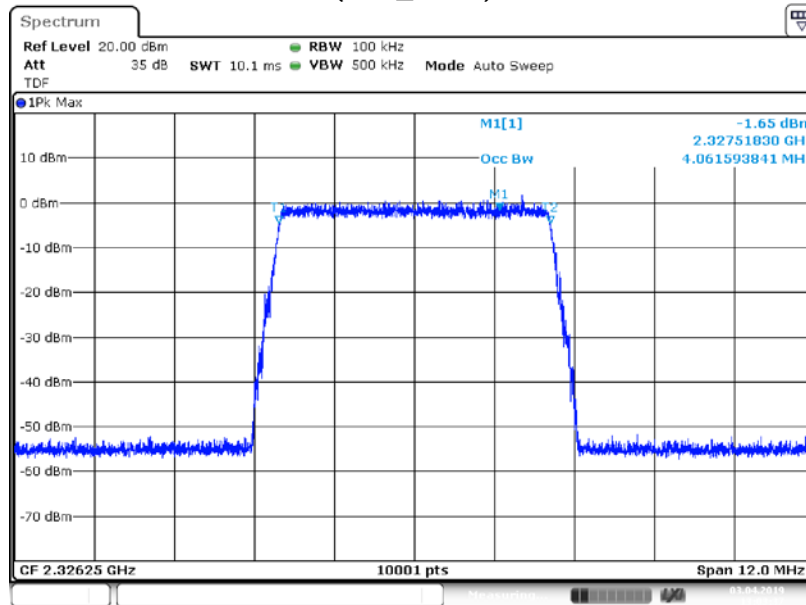

3.4 OCBw COFDM In +3 2.32620 _99

Input Signal

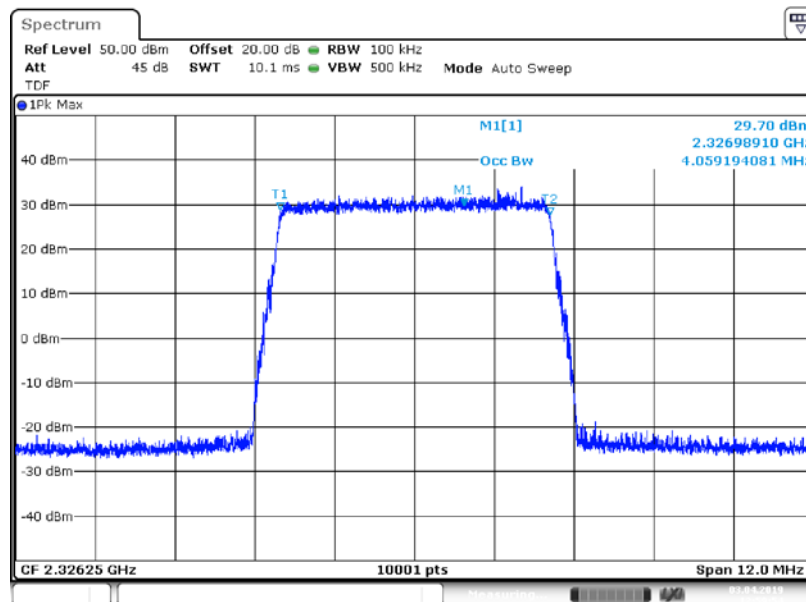

3.4 OCBw COFDM Out +3;2.32620 _99

Output Signal

Frequency Band = High [XM], Direction = RF downlink, Input Power = 0.3 dB < AGC, Signal Type = AWGN (S01_AA01)

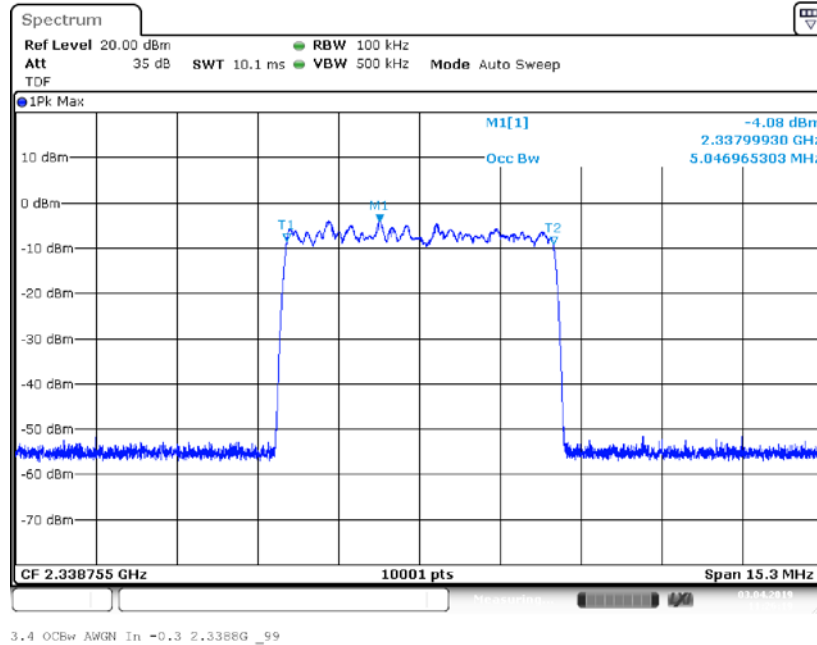

Input Signal

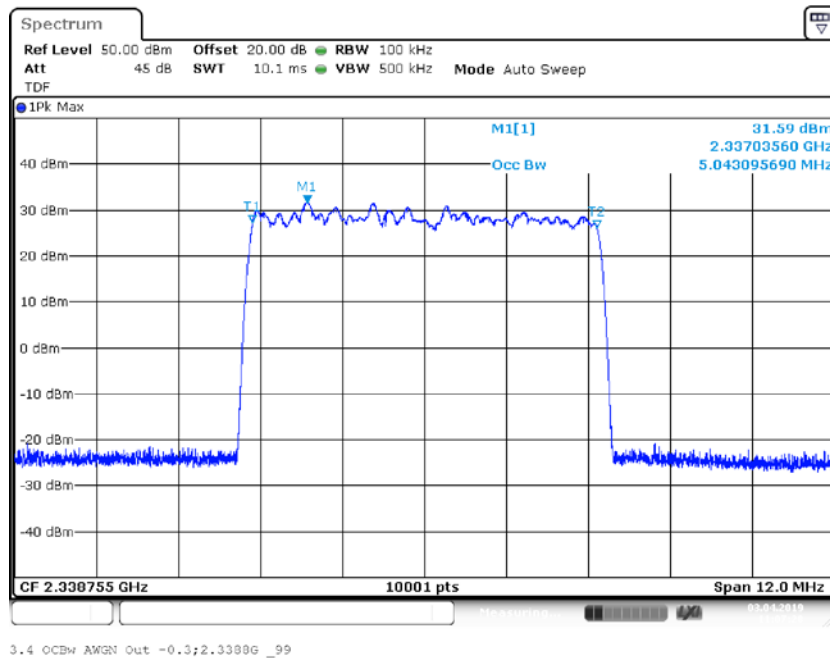

Output Signal

Frequency Band = High [XM], Direction = RF downlink, Input Power = 0.3 dB < AGC, Signal Type = COFDM (S01_AA01)

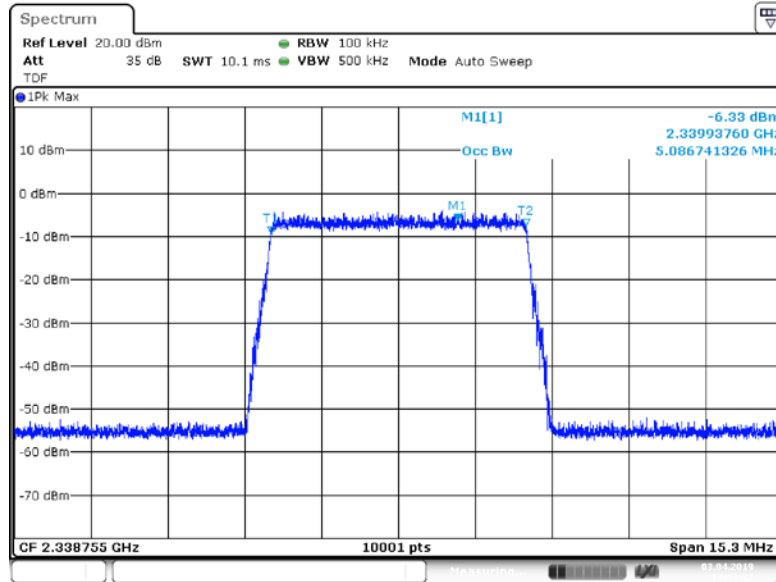

3.4 OCBW COFDM In -0.3 2.3388G _99

Input Signal

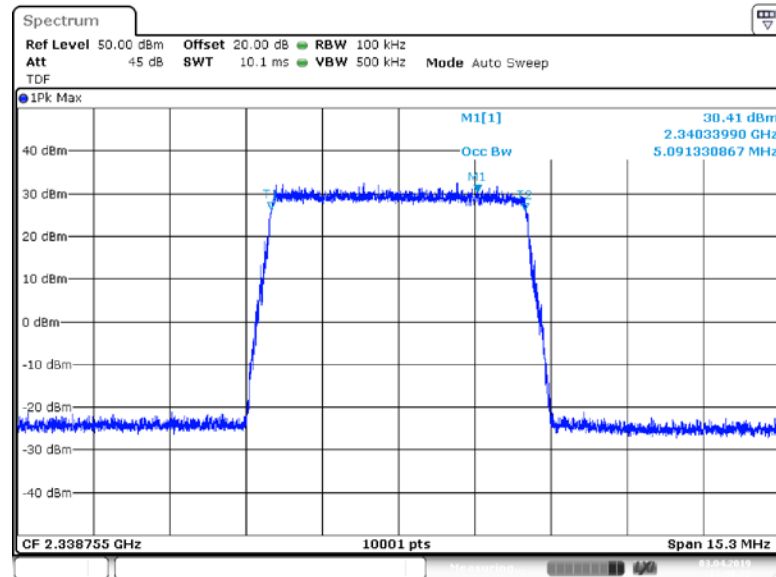

3.4 OCBW COFDM Out -0.3;2.3388G _99

Output Signal

Frequency Band = High [XM], Direction = RF downlink, Input Power = 3 dB > AGC, Signal Type = AWGN (S01_AA01)

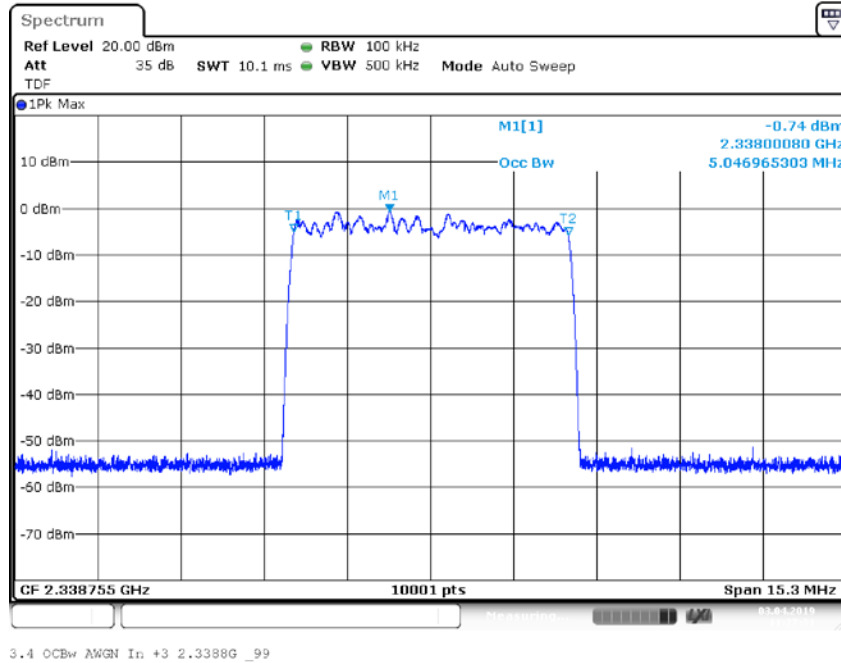

Input Signal

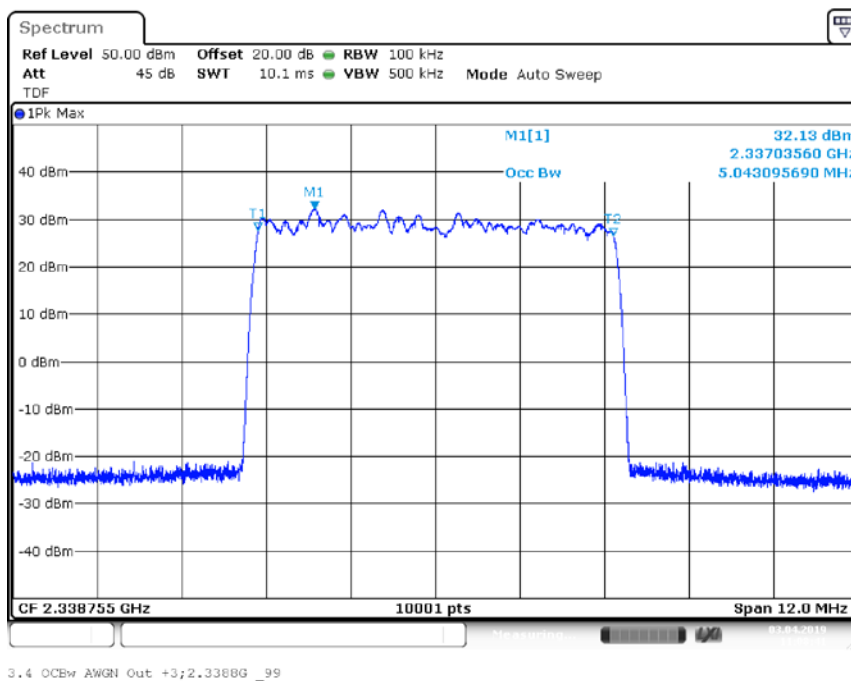

Output Signal

Frequency Band = High [XM], Direction = RF downlink, Input Power = 3 dB > AGC, Signal Type = COFDM (S01_AA01)

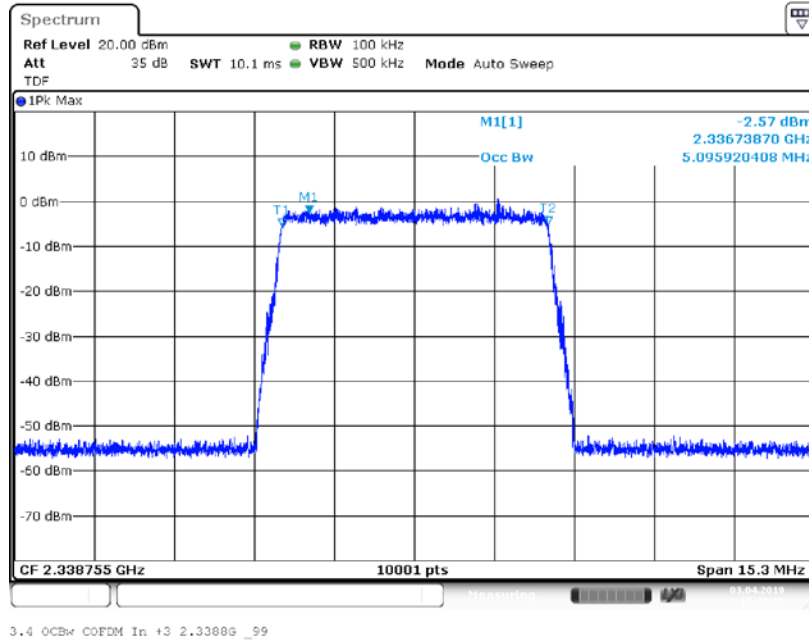

Input Signal

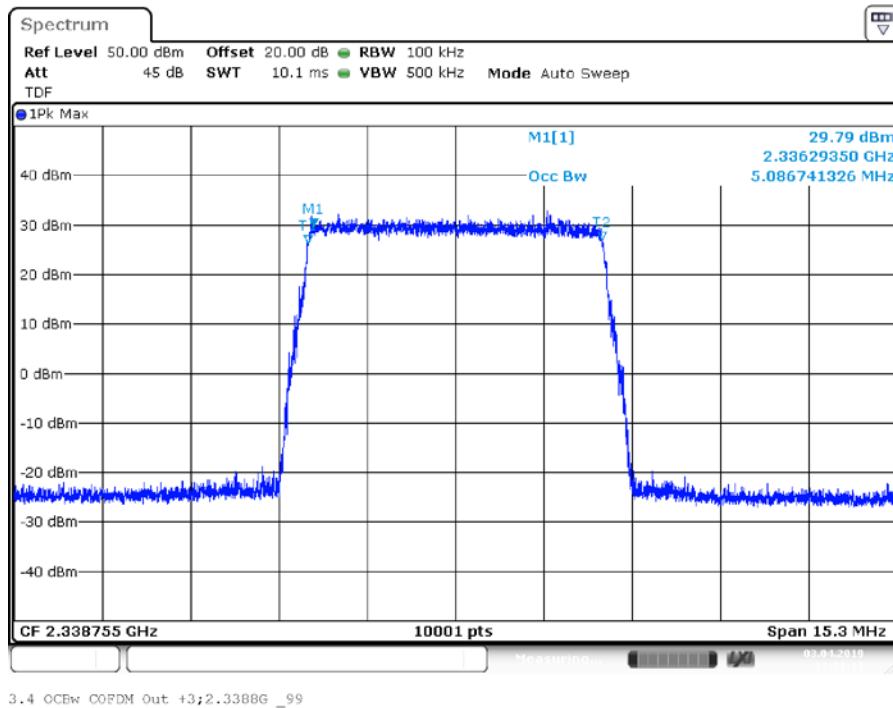

Output Signal

4.3.5 TEST EQUIPMENT USED

FCC Conducted Base Station / Repeater

4.4 CONDUCTED SPURIOUS EMISSIONS AT ANTENNA TERMINALS

Standard FCC Part §2.1051, §25.202

The test was performed according to:
ANSI C63.26

4.4.1 TEST DESCRIPTION

This test case is intended to demonstrate compliance to the signal booster power and gain limits and requirements for industrial signal boosters.

The EUT was connected to the test setup according to the following diagram:

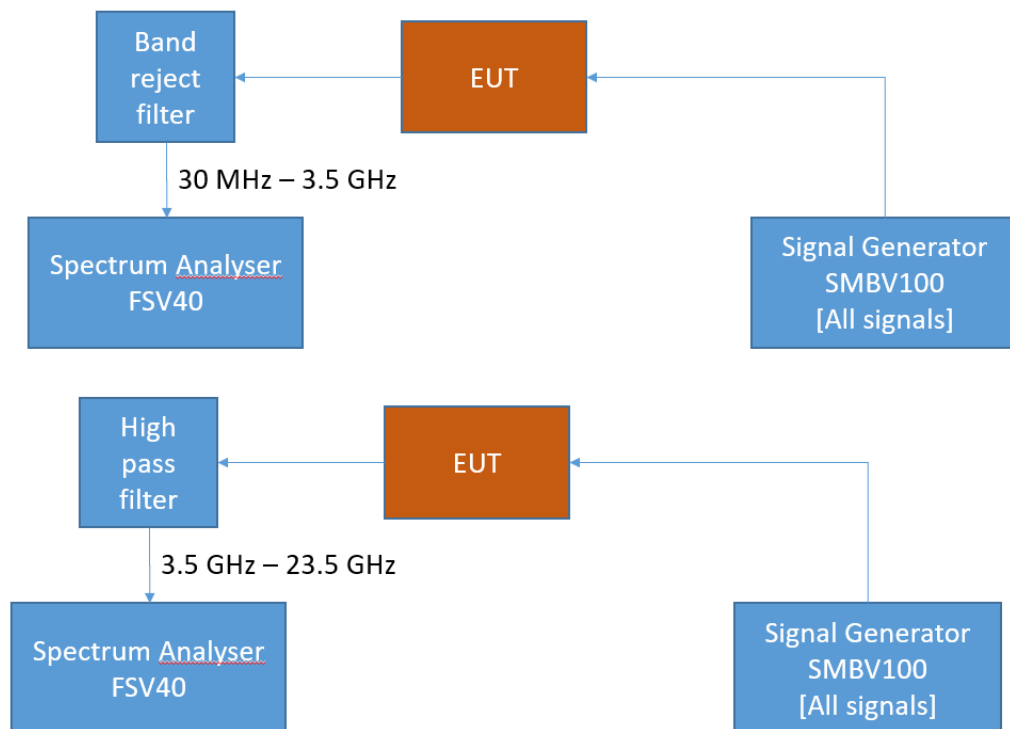

FCC Part 25; Satellite signal booster – Test Setup; Conducted Spurious Emissions

The attenuation of the measuring and stimulus path are known for each measured frequency and are considered.

The Spectrum Analyzer settings can be directly found in the measurement diagrams.

4.4.2 TEST REQUIREMENTS / LIMITS

FCC Part 2.1051; Measurement required: Spurious emissions at antenna terminal:

The radio frequency voltage or powers generated within the equipment and appearing on a spurious frequency shall be checked at the equipment output terminals when properly loaded with a suitable artificial antenna. Curves or equivalent data shall show the magnitude of each harmonic and other spurious emission that can be detected when the equipment is operated under the conditions specified in §2.1049 as appropriate. The magnitude of spurious emissions which are attenuated more than 20 dB below the permissible value need not be specified.

Part 25; Satellite Communications

Subpart C – Technical standards

§25.202 – Frequencies, frequency tolerance and emission limits

h) *Out-of-band emission limitations for SDARS terrestrial repeaters.* (1) Any SDARS terrestrial repeater operating at a power level greater than 2-watt average EIRP is required to attenuate its out-of-band emissions below the transmitter power P by a factor of not less than $90 + 10 \log (P)$ dB in a 1-megahertz bandwidth outside the 2320-2345 MHz band, where P is average transmitter output power in watts.

(2) Any SDARS terrestrial repeater operating at a power level equal to or less than 2-watt average EIRP is required to attenuate its out-of-band emissions below the transmitter power P by a factor of not less than $75 + 10 \log (P)$ dB in a 1-megahertz bandwidth outside the 2320-2345 MHz band, where P is average transmitter output power in watts.

4.4.3 TEST PROTOCOL

Low [Sirius], downlink							
Test Frequency	Signal Type	Spurious Freq. [MHz]	Spurious Level [dBm]	Detector	RBW [kHz]	Limit [dBm]	Margin to Limit [dB]
mid	AWGN	2319.000	-65.0	RMS	1000	-60.0	5.0
mid	AWGN	2355.232	-66.0	RMS	1000	-60.0	6.0
mid	AWGN	20389.375	-66.3	RMS	1000	-60.0	6.3
mid	COFDM	2319.000	-65.8	RMS	1000	-60.0	5.8
mid	COFDM	2354.691	-66.7	RMS	1000	-60.0	6.7
mid	COFDM	20385.875	-66.2	RMS	1000	-60.0	6.2

High [XM], downlink							
Test Frequency	Signal Type	Spurious Freq. [MHz]	Spurious Level [dBm]	Detector	RBW [kHz]	Limit [dBm]	Margin to Limit [dB]
mid	AWGN	2319.000	-65.2	RMS	1000	-60.0	5.2
mid	AWGN	2354.367	-66.5	RMS	1000	-60.0	6.2
mid	AWGN	20391.156	-66.3	RMS	1000	-60.0	6.3
mid	COFDM	2318.928	-66.2	RMS	1000	-60.0	6.2
mid	COFDM	2355.232	-66.8	RMS	1000	-60.0	6.8
mid	COFDM	20385.656	-66.3	RMS	1000	-60.0	6.3

Remark: The two test signals were injected simultaneously conducted into the EUT.
Please see next sub-clause for the measurement plot.

4.4.4 MEASUREMENT PLOT (SHOWING THE HIGHEST VALUE, "WORST CASE")

Frequency Band = Low [Sirius], Test Frequency = mid, Direction = RF downlink, Signal Type = AWGN
(S01_AA01)

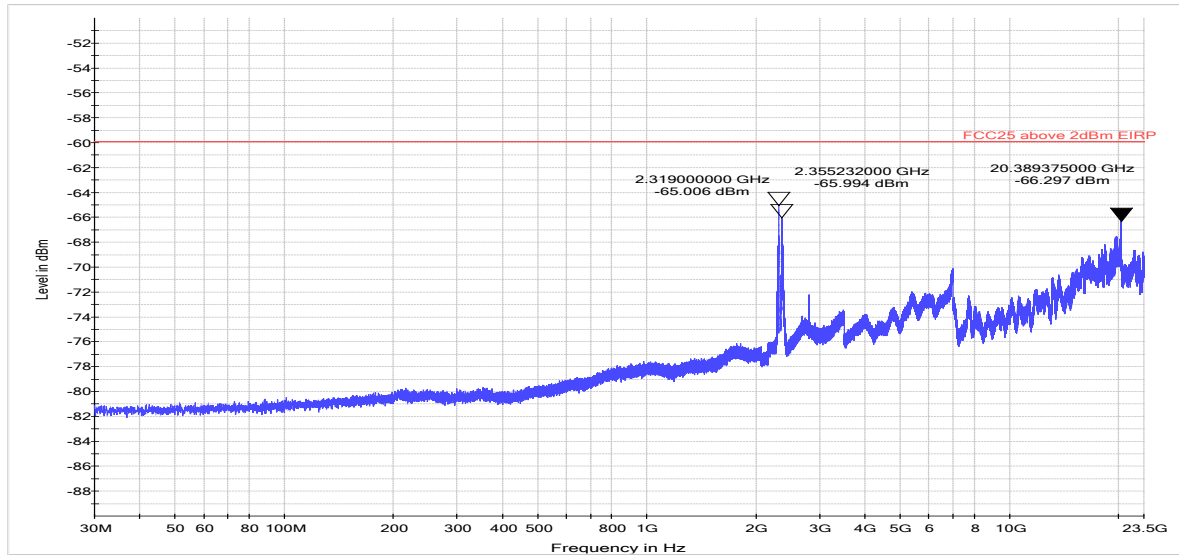

Frequency Band = High [XM], Test Frequency = mid, Direction = RF downlink, Signal Type = AWGN
(S01_AA01)

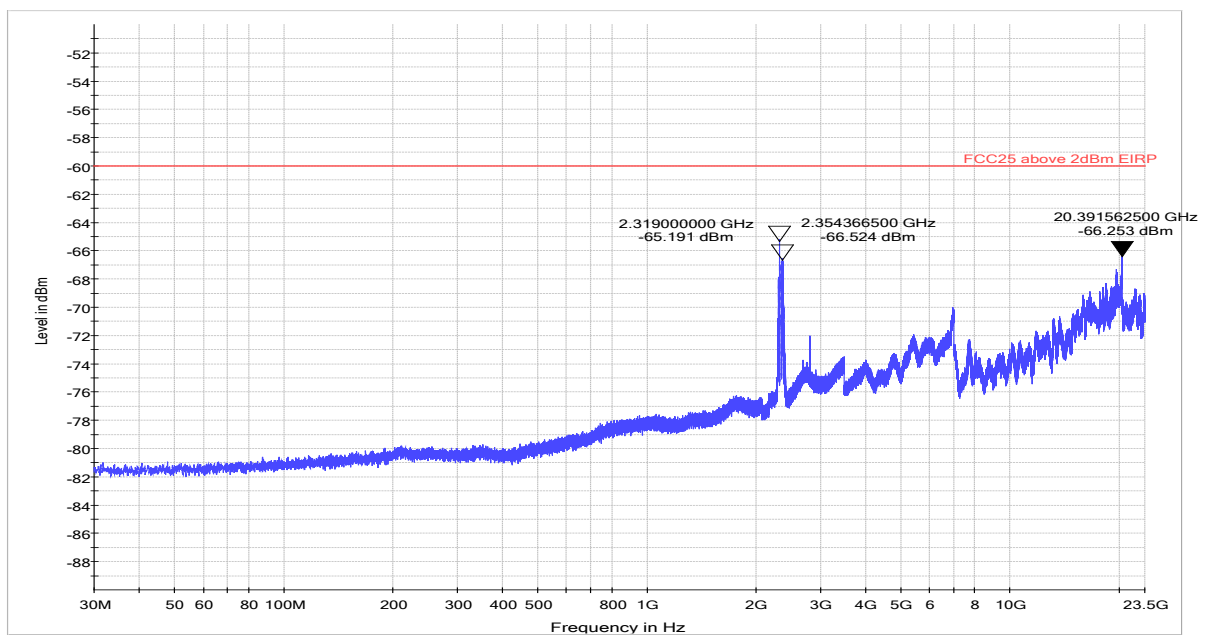

Frequency Band = Low [Sirius], Test Frequency = mid, Direction = RF downlink, Signal Type = COFDM (S01_AA01)

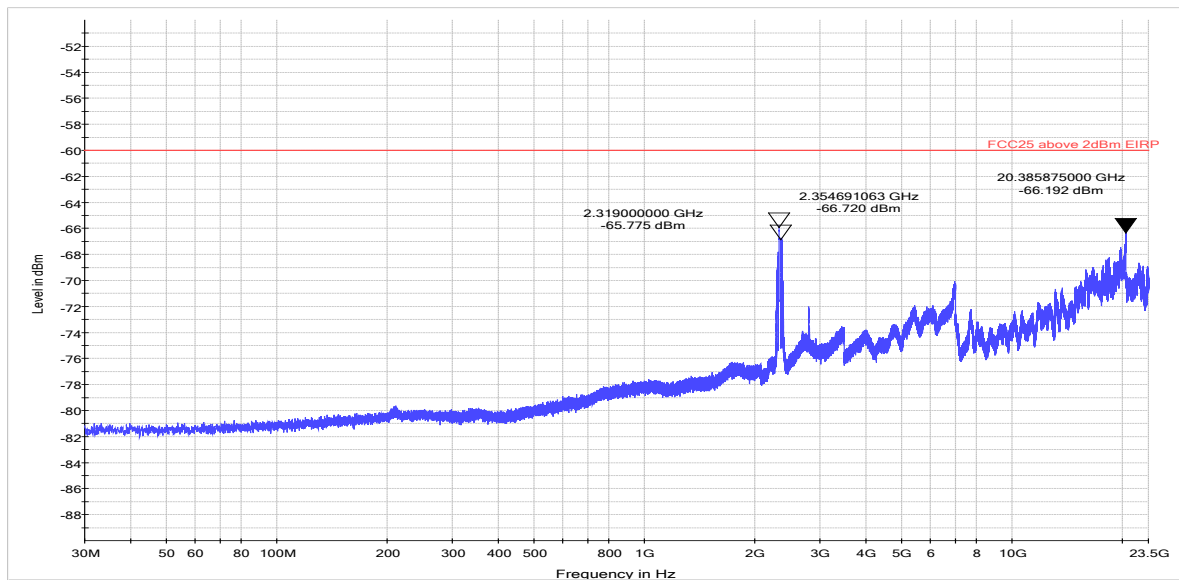

Frequency Band = High [XM], Test Frequency = mid, Direction = RF downlink, Signal Type = COFDM (S01_AA01)

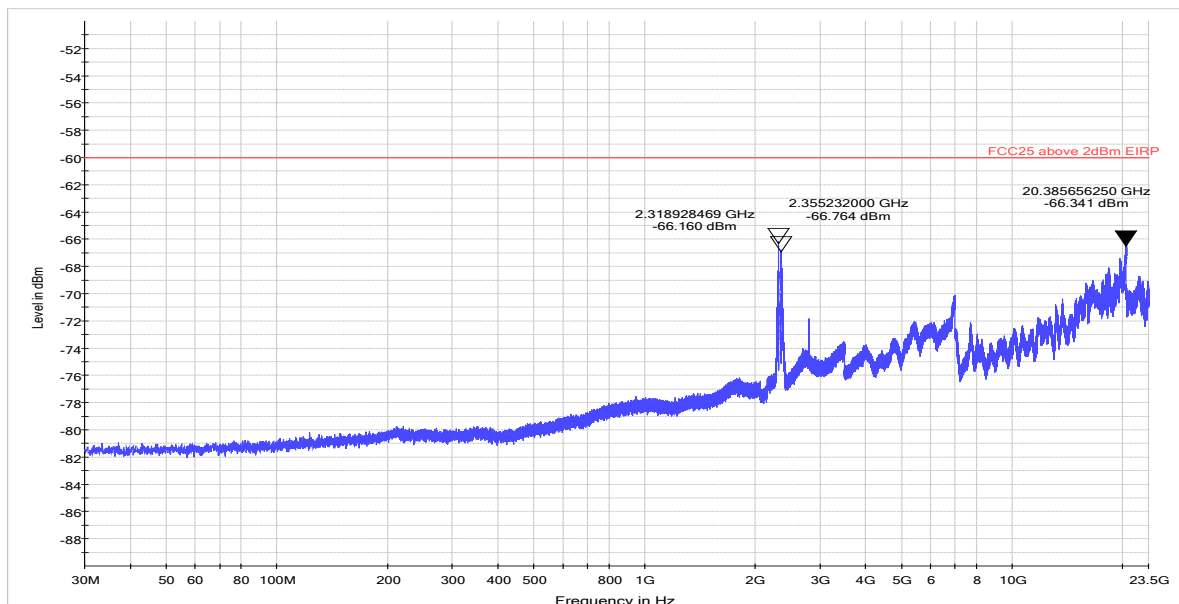

4.4.5 TEST EQUIPMENT USED

- R&S TS8997

4.5 OUT-OF-BAND EMISSION LIMITS

Standard FCC Part §2.1051, §25.202

The test was performed according to:
ANSI C63.26

4.5.1 TEST DESCRIPTION

This test case is intended to demonstrate compliance to the out-of-band emission limit for industrial signal boosters. The limits itself come from the applicable rule part for each operating band.

The EUT was connected to the test setup according to the following diagram:

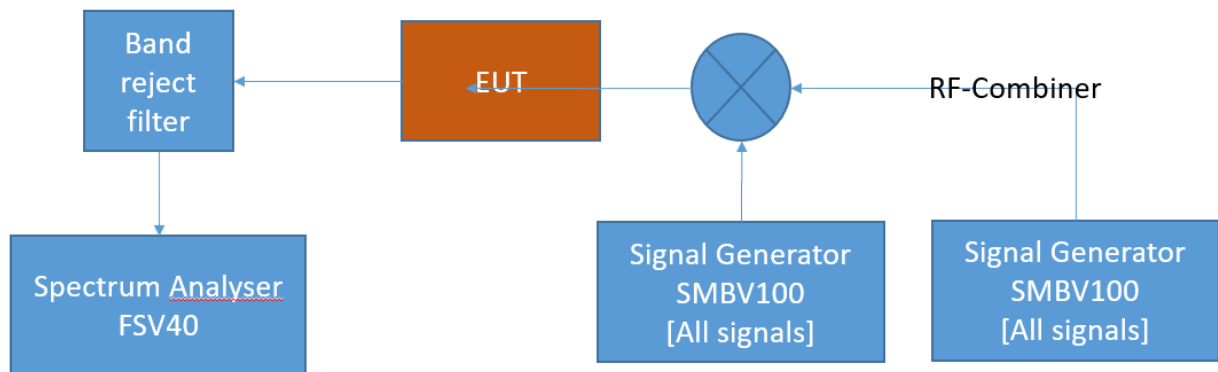

FCC Part 25; Satellite signal booster – Test Setup; Out-of-band emissions

The attenuation of the measuring and stimulus path are known for each measured frequency and are considered.

The Spectrum Analyzer settings can be directly found in the measurement diagrams.

4.5.2 TEST REQUIREMENTS / LIMITS

FCC Part 2.1051; Measurement required: Spurious emissions at antenna terminal:

The radio frequency voltage or powers generated within the equipment and appearing on a spurious frequency shall be checked at the equipment output terminals when properly loaded with a suitable artificial antenna. Curves or equivalent data shall show the magnitude of each harmonic and other spurious emission that can be detected when the equipment is operated under the conditions specified in §2.1049 as appropriate. The magnitude of spurious emissions which are attenuated more than 20 dB below the permissible value need not be specified.

Part 25; Satellite Communications

Subpart C – Technical standards

§25.202 – Frequencies, frequency tolerance and emission limits

h) *Out-of-band emission limitations for SDARS terrestrial repeaters.* (1) Any SDARS terrestrial repeater operating at a power level greater than 2-watt average EIRP is required to attenuate its out-of-band emissions below the transmitter power P by a factor of not less than $90 + 10 \log (P)$ dB in a 1-megahertz bandwidth outside the 2320-2345 MHz band, where P is average transmitter output power in watts.

(2) Any SDARS terrestrial repeater operating at a power level equal to or less than 2-watt average EIRP is required to attenuate its out-of-band emissions below the transmitter power P by a factor of not less than $75 + 10 \log (P)$ dB in a 1-megahertz bandwidth outside the 2320-2345 MHz band, where P is average transmitter output power in watts.

4.5.3 TEST PROTOCOL

Low [Sirius], downlink									
Test Freq.	Signal Type	Input Power	Band Edge	Spurious Freq. [MHz]	Spurious Level [dBm]	Detector	RBW [kHz]	Limit [dBm]	Margin to Limit [dB]
mid	AWGN	0.3 dB < AGC	Low	*)	-71.4	RMS	1000	-60.0	11.4
mid	COFDM	0.3 dB < AGC	Low	*)	-72.7	RMS	1000	-60.0	12.7
mid	AWGN	3 dB > AGC	Low	*)	-70.1	RMS	1000	-60.0	10.1
mid	COFDM	3 dB > AGC	Low	*)	-73.7	RMS	1000	-60.0	13.7

High [XM], downlink									
Test Freq.	Signal Type	Input Power	Band Edge	Spurious Freq. [MHz]	Spurious Level [dBm]	Detector	RBW [kHz]	Limit [dBm]	Margin to Limit [dB]
mid	AWGN	0.3 dB < AGC	High	*)	-71.0	RMS	1000	-60.0	11.0
mid	COFDM	0.3 dB < AGC	High	*)	-72.2	RMS	1000	-60.0	12.2
mid	AWGN	3 dB > AGC	High	*)	-70.9	RMS	1000	-60.0	10.9
mid	COFDM	3 dB > AGC	High	*)	-71.9	RMS	1000	-60.0	11.9

Remark: *) For the spurious frequency please see measurement plot
 The two test signals were injected simultaneously conducted into the EUT.
 Since EUT cannot transmit at two adjacent frequencies simultaneously, intermodulation assessment is not applicable.
 Please see next sub-clause for the measurement plot

4.5.4 MEASUREMENT PLOT (SHOWING THE HIGHEST VALUE, "WORST CASE")

Band Edge = Low, Frequency Band = Low[Sirius], Direction = RF downlink, Input Power = 0.3 dB < AGC, Signal Type = AWGN, Test Frequency = mid (S01_AA01)

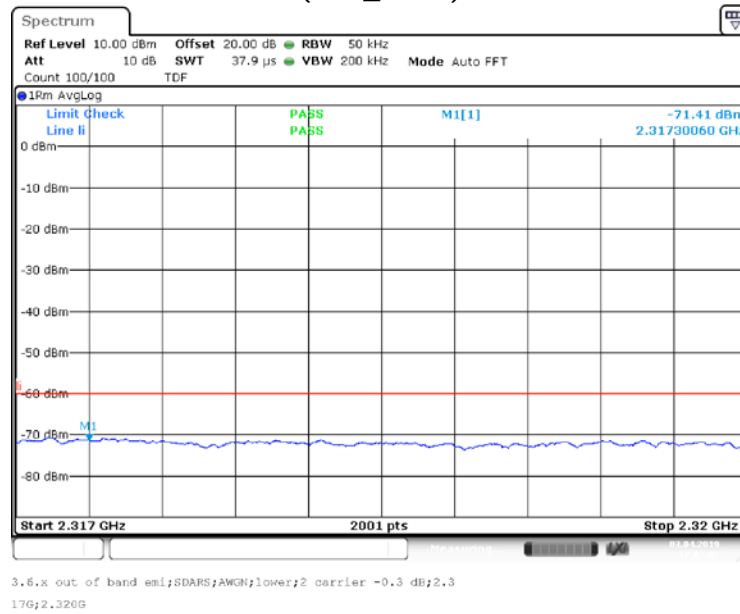

Band Edge = Low, Frequency Band = Low[Sirius], Direction = RF downlink, Input Power = 0.3 dB < AGC, Signal Type = COFDM, Test Frequency = mid (S01_AA01)

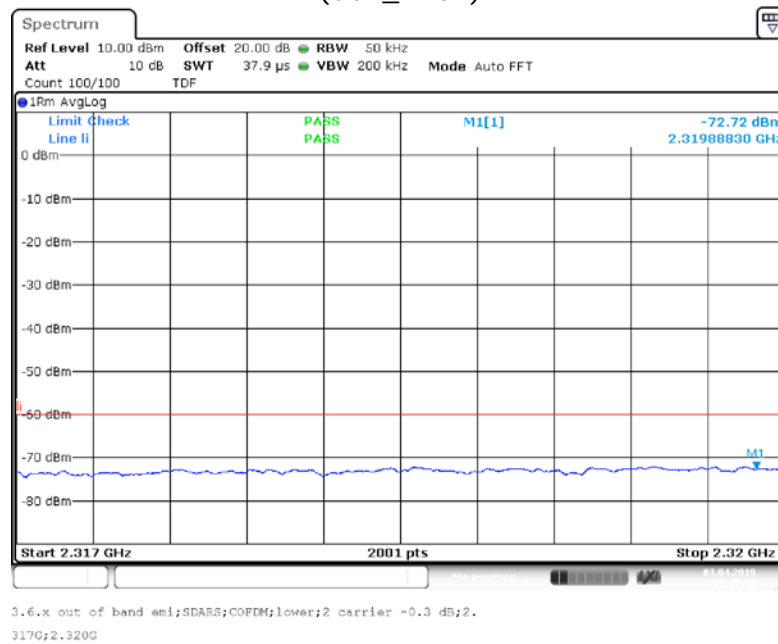

Band Edge = Lower, Frequency Band = Low[Sirius], Direction = RF downlink,
Input Power = 3 dB > AGC, Signal Type = AWGN, Test Frequency = mid
(S01_AA01)

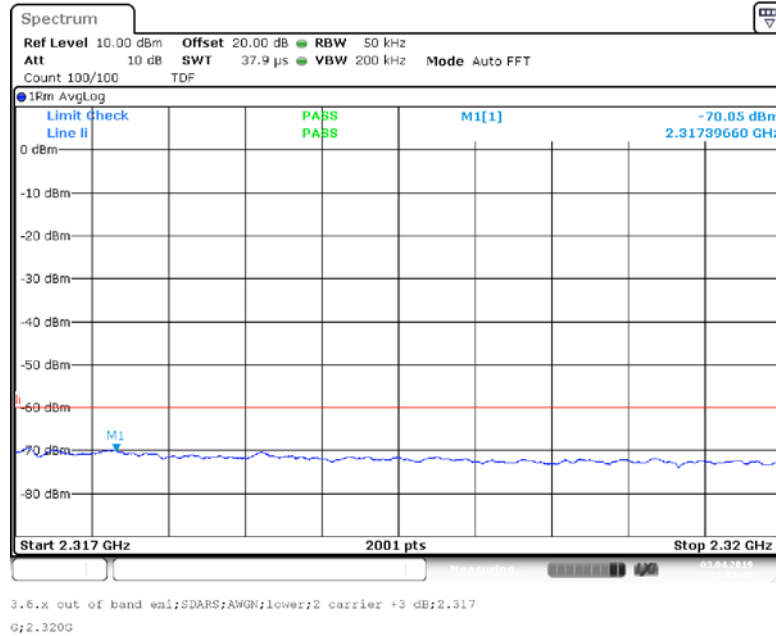

Band Edge = Lower, Frequency Band = Low[Sirius], Direction = RF downlink,
Input Power = 3 dB > AGC, Signal Type = COFDM, Test Frequency = mid
(S01_AA01)

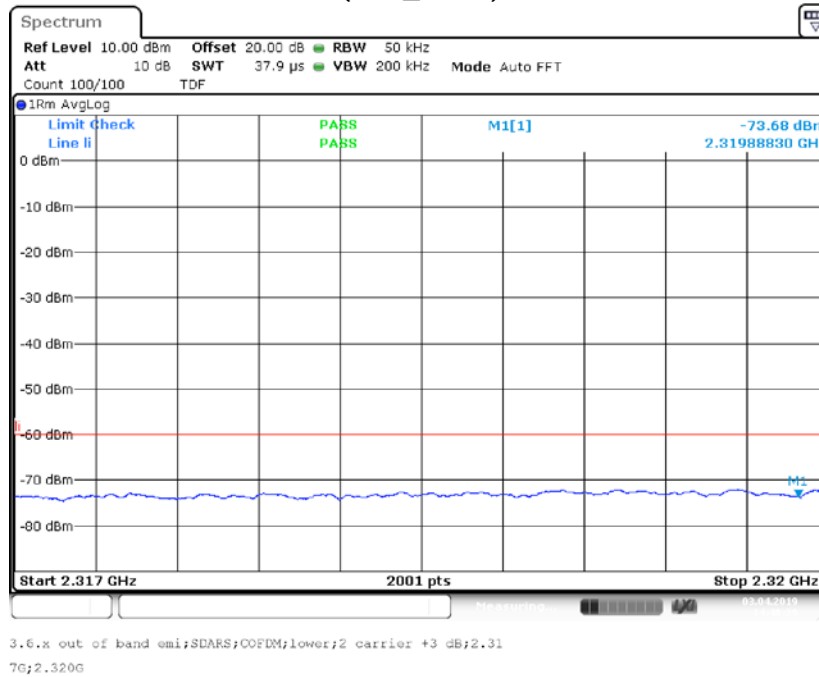

Band Edge = High, Frequency Band = High[XM], Direction = RF downlink,
Input Power = 0.3 dB < AGC, Signal Type = AWGN, Test Frequency = mid
(S01_AA01)

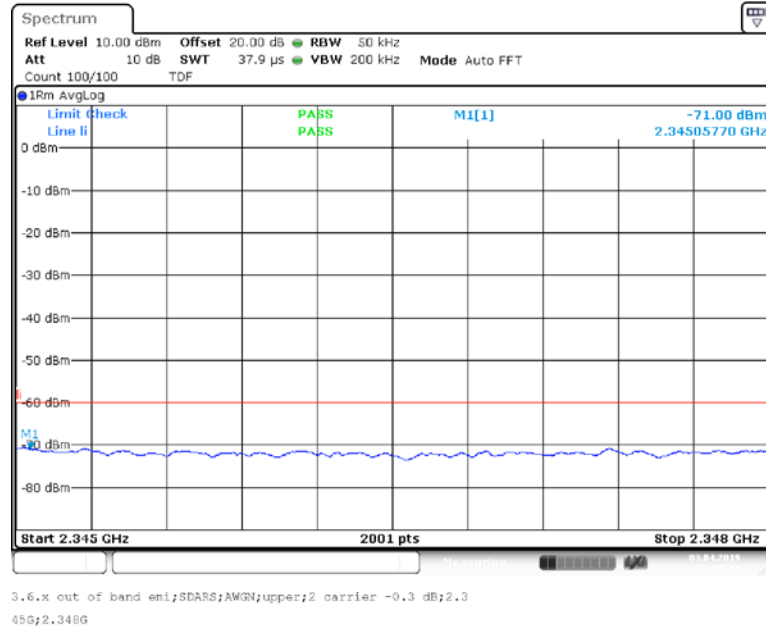

Band Edge = High, Frequency Band = High[XM], Direction = RF downlink,
Input Power = 0.3 dB < AGC, Signal Type = COFDM, Test Frequency = mid
(S01_AA01)

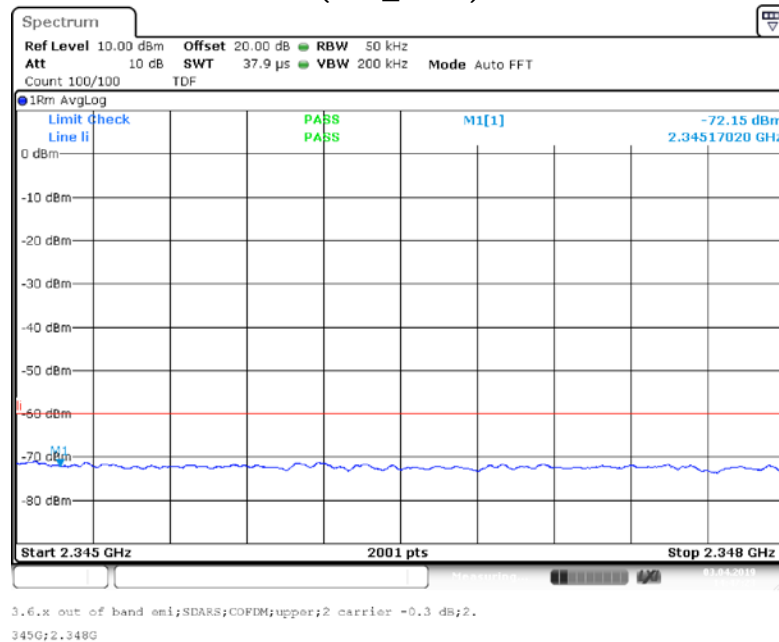

Band Edge = High, Frequency Band = High[XM], Direction = RF downlink,
Input Power = 3 dB > AGC, Signal Type = AWGN, Test Frequency = mid
(S01_AA01)

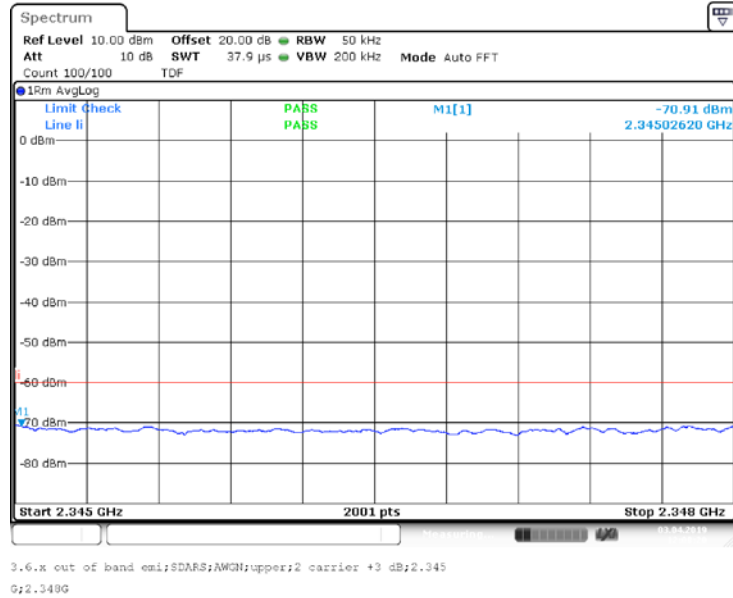

Band Edge = High, Frequency Band = High[XM], Direction = RF downlink,
Input Power = 3 dB > AGC, Signal Type = COFDM, Test Frequency = mid
(S01_AA01)

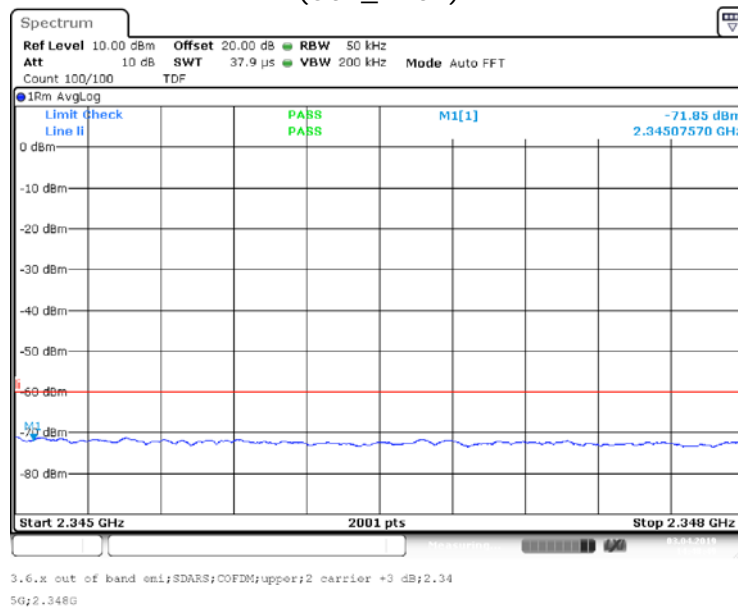

4.5.5 TEST EQUIPMENT USED

- FCC Conducted Base Station / Repeater

4.6 FIELD STRENGTH OF SPURIOUS RADIATION

Standard FCC Part §2.1053, §25.202

The test was performed according to:
ANSI C63.26

4.6.1 TEST DESCRIPTION

This test case is intended to demonstrate compliance to the applicable radiated spurious emission measurements per § 2.1053

The EUT was connected to the test setup according to the following diagram:

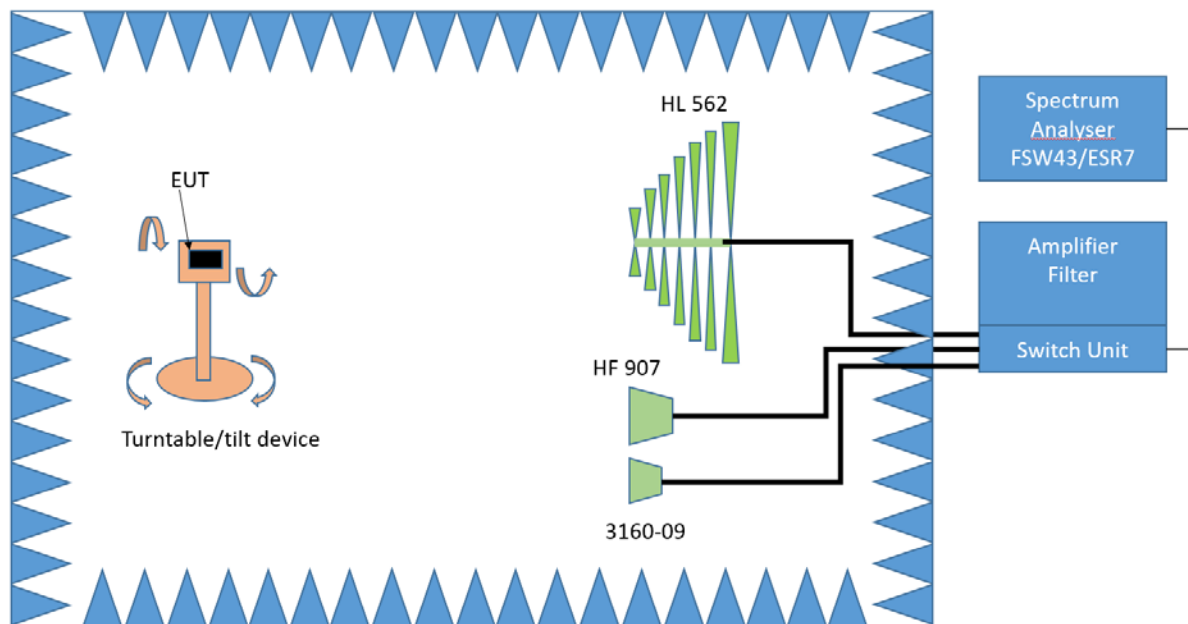

FCC Part 22/24/27/90; Industrial Signal Booster – Test Setup; Field Strength of Spurious Radiation

The test set-up was made in accordance to the general provisions of ANSI C63.4 in a typical installation configuration. The Equipment Under Test (EUT) was set up on a non-conductive table 1.0 x 2.0 m² in the semi-anechoic chamber. The influence of the EUT support table that is used between 30–1000 MHz was evaluated.

The measurement procedure is implemented into the EMI test software EMC32 from R&S. Exploratory tests are performed at 3 orthogonal axes to determine the worst-case orientation of a body-worn or handheld EUT. The final test on all kind of EUTs is also performed at 3 axes. A pre-check is performed while the EUT is powered from a DC power source.

1. Measurement above 30 MHz and up to 1 GHz

Step 1: Preliminary scan

This is a preliminary test to identify the highest amplitudes relative to the limit.

Settings for step 1:

- Antenna distance: 3 m
- Detector: Peak-Maxhold / Quasipeak (FFT-based)

- Frequency range: 30 – 1000 MHz
- Frequency steps: 30 kHz
- IF-Bandwidth: 120 kHz
- Measuring time / Frequency step: 100 ms
- Turntable angle range: -180° to 90°
- Turntable step size: 90°
- Height variation range: 1 – 3 m
- Height variation step size: 2 m
- Polarisation: Horizontal + Vertical

Intention of this step is, to determine the radiated EMI-profile of the EUT. Afterwards the relevant emissions for the final measurement are identified.

Step 2: Adjustment measurement

In this step the accuracy of the turntable azimuth and antenna height will be improved. This is necessary to find out the maximum value of every frequency.

For each frequency, which was determined the turntable azimuth and antenna height will be adjusted. The turntable azimuth will slowly vary by $\pm 45^{\circ}$ around this value. During this action, the value of emission is continuously measured. The turntable azimuth at the highest emission will be recorded and adjusted. In this position, the antenna height will also slowly vary by ± 100 cm around the antenna height determined. During this action, the value of emission is also continuously measured. The antenna height of the highest emission will also be recorded and adjusted.

- Detector: Peak – Maxhold
- Measured frequencies: in step 1 determined frequencies
- IF – Bandwidth: 120 kHz
- Measuring time: 100 ms
- Turntable angle range: $\pm 45^{\circ}$ around the determined value
- Height variation range: ± 100 cm around the determined value
- Antenna Polarisation: max. value determined in step 1

Step 3: Final measurement with QP detector

With the settings determined in step 3, the final measurement will be performed:

EMI receiver settings for step 4:

- Detector: Quasi-Peak (< 1 GHz)
- Measured frequencies: in step 1 determined frequencies
- IF – Bandwidth: 120 kHz
- Measuring time: 1 s

After the measurement a plot will be generated which contains a diagram with the results of the preliminary scan and a chart with the frequencies and values of the results of the final measurement.

3. Measurement above 1 GHz

The following modifications apply to the measurement procedure for the frequency range above 1 GHz:

Step 1:

The Equipment Under Test (EUT) was set up on a non-conductive support (tilt device) at 1.5 m height in the fully-anechoic chamber.

All steps were performed with one height (1.5 m) of the receiving antenna only.

The EUT is turned during the preliminary measurement across the elevation axis, with a step size of 90° .

The turn table step size (azimuth angle) for the preliminary measurement is 45° .

Step 2:

Due to the fact, that in this frequency range the test is performed in a fully anechoic room, the height scan of the receiving antenna instead 2 is omitted. Instead of this, a maximum search with a step size $\pm 45^\circ$ for the elevation axis is performed.

The turn table azimuth will slowly vary by $\pm 22.5^\circ$.

The elevation angle will slowly vary by $\pm 45^\circ$

EMI receiver settings (for all steps):

- Detector: Peak, Average
- IF Bandwidth = 1 MHz

Step 3:

Spectrum analyser settings for step 3:

- Detector: Peak / Average
- Measured frequencies: in step 1 determined frequencies
- IF – Bandwidth: 1 MHz
- Measuring time: 1 s

4.6.2 TEST REQUIREMENTS / LIMITS

FCC Part 2.1053; Measurement required: Field strength of spurious radiation:

Measurements shall be made to detect spurious emissions that may be radiated directly from the cabinet, control circuits, power leads, or intermediate circuit elements under normal conditions of installation and operation. Curves or equivalent data shall be supplied showing the magnitude of each harmonic and other spurious emission. For this test, single sideband, independent sideband, and controlled carrier transmitters shall be modulated under the conditions specified in paragraph (c) of §2.1049, as appropriate.

Part 25; Satellite Communications

Subpart C – Technical standards

§25.202 – Frequencies, frequency tolerance and emission limits

h) *Out-of-band emission limitations for SDARS terrestrial repeaters.* (1) Any SDARS terrestrial repeater operating at a power level greater than 2-watt average EIRP is required to attenuate its out-of-band emissions below the transmitter power P by a factor of not less than $90 + 10 \log (P)$ dB in a 1-megahertz bandwidth outside the 2320-2345 MHz band, where P is average transmitter output power in watts.

(2) Any SDARS terrestrial repeater operating at a power level equal to or less than 2-watt average EIRP is required to attenuate its out-of-band emissions below the transmitter power P by a factor of not less than $75 + 10 \log (P)$ dB in a 1-megahertz bandwidth outside the 2320-2345 MHz band, where P is average transmitter output power in watts.

4.6.3 TEST PROTOCOL

Low [Sirius] / High [XM], downlink, AWGN						
Spurious Freq. [MHz]	Spurious Level [dBm]	Pin [dBm]	Detector	RBW [kHz]	Limit [dBm]	Margin to Limit [dB]
90.916	-64.7 *)	4.8	RMS	1000	-60.0	4.7
98.094	-64.1 *)	4.8	RMS	1000	-60.0	4.1
105.078	-63.9 *)	4.8	RMS	1000	-60.0	3.9
112.256	-66.2 *)	4.8	RMS	1000	-60.0	6.2
119.434	-65.0 *)	4.8	RMS	1000	-60.0	5.0
4666.00	-65.9 *)	4.8	RMS	1000	-60.0	5.9

Low [Sirius] / High [XM], downlink, COFDM						
Spurious Freq. [MHz]	Spurious Level [dBm]	Pin [dBm]	Detector	RBW [kHz]	Limit [dBm]	Margin to Limit [dB]
90.819	-65.3 *)	6.2	RMS	1000	-60.0	5.3
97.997	-64.6 *)	6.2	RMS	1000	-60.0	4.6
104.593	-64.5 *)	6.2	RMS	1000	-60.0	4.5
111.868	-66.5 *)	6.2	RMS	1000	-60.0	6.5
119.240	-65.2 *)	6.2	RMS	1000	-60.0	5.2
4665.000	-64.6 *)	6.2	RMS	1000	-60.0	4.6

Remark: Please see next sub-clause for the measurement plot.

The two required test frequencies (low, , high) were injected simultaneously conducted into the EUT.

The RF output ports were terminated with 50 Ohm

Pin: The composite power of both signals.

*) → blue rhomb in measurement plot

4.6.4 MEASUREMENT PLOT (SHOWING THE HIGHEST VALUE, "WORST CASE")

Frequency Band = Band Low[Sirius] / High [XM], Test Frequency = mid,
 Direction = RF downlink, Test Signal = AWGN
 (S01_AA01)

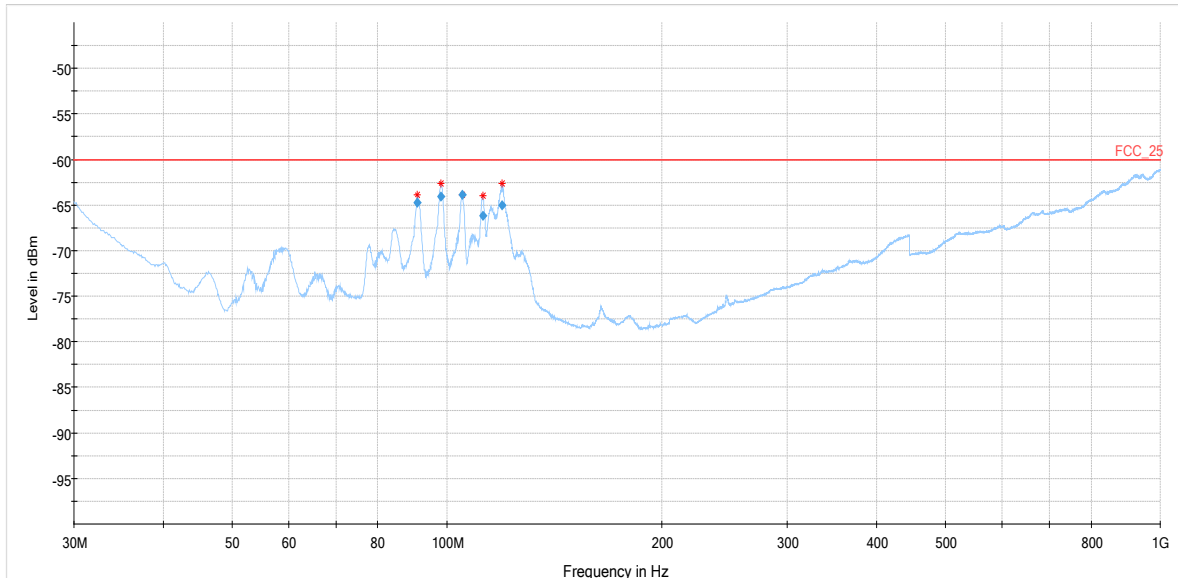

30 MHz - 1 GHz

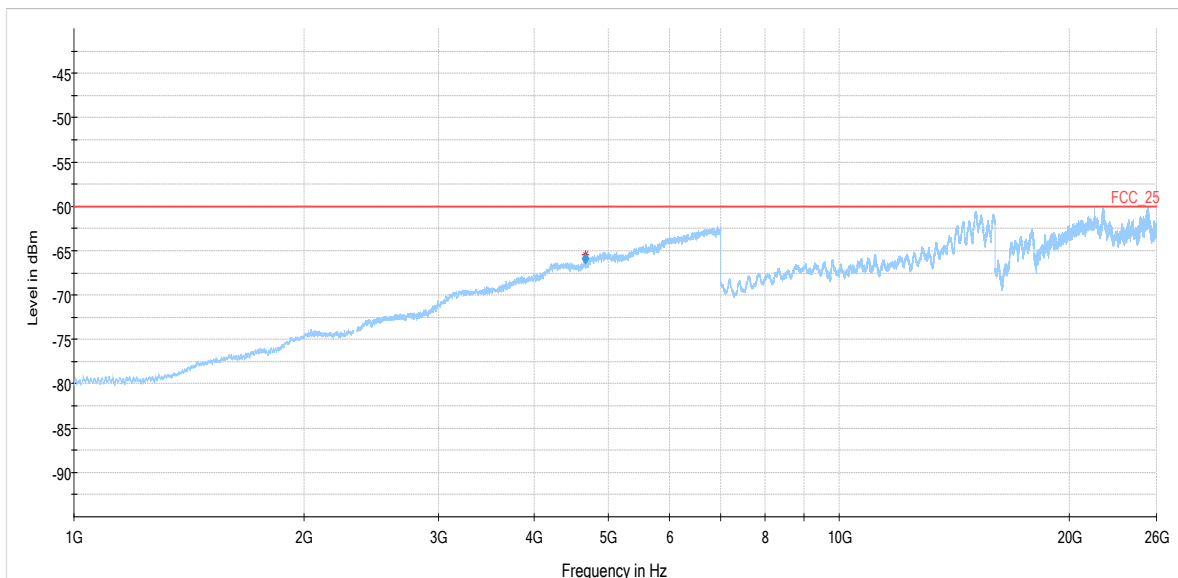

1 GHz - 26 GHz

Frequency Band = Band Low[Sirius] / High [XM], Test Frequency = mid,
 Direction = RF downlink, Test Signal = COFDM
 (S01_AA01)

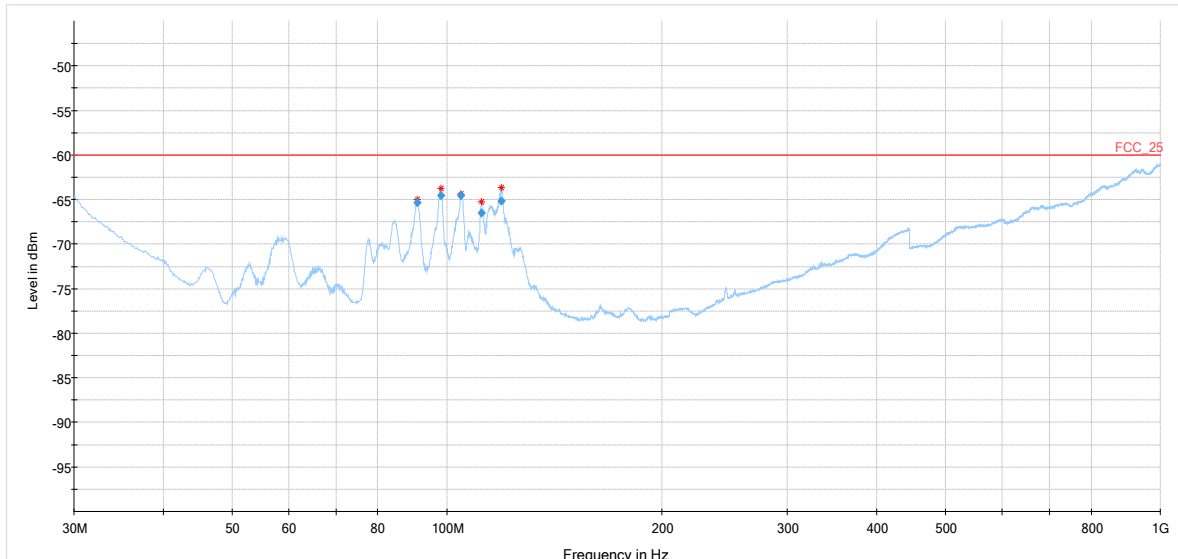

30 MHz - 1 GHz

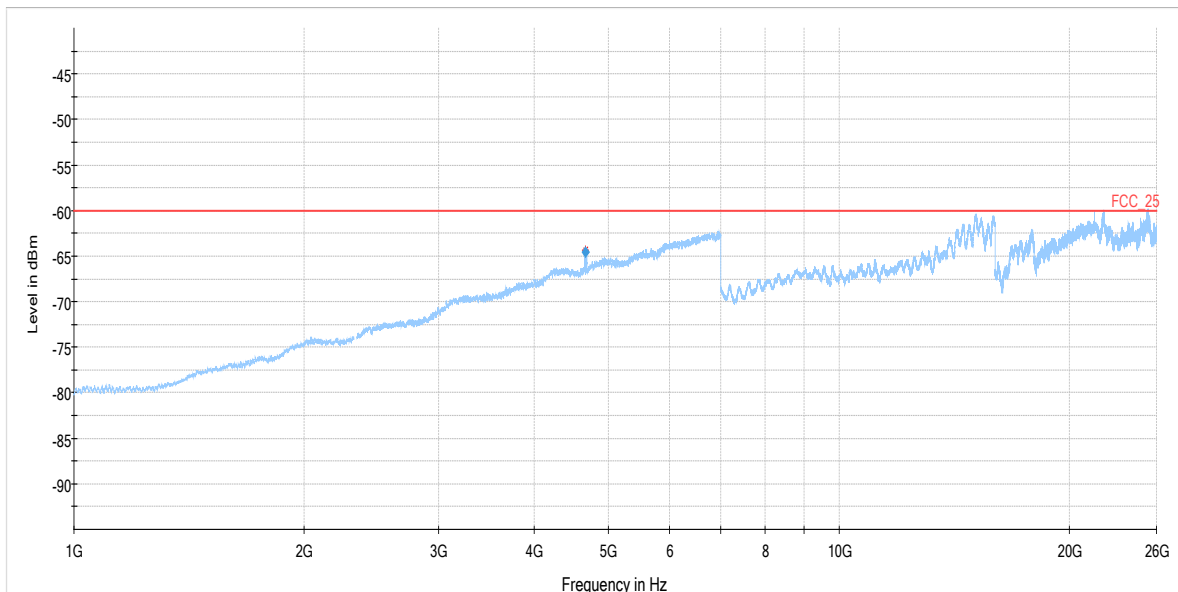

1 GHz - 26 GHz

4.6.5 TEST EQUIPMENT USED

- Radiated Emissions

5 TEST EQUIPMENT

- 1 R&S TS8997
EN300328/301893/FCC cond. Test Lab

Ref.No.	Device Name	Description	Manufacturer	Serial Number	Last Calibration	Calibration Due
1.1	SMB100A	Signal Generator 9 kHz - 6 GHz	Rohde & Schwarz	107695	2017-07	2020-07
1.2	MFS	Rubidium Frequency Standard	Datum-Beverly	5489/001	2018-07	2020-07
1.3	1515 / 93459	Broadband Power Divider SMA (Aux)	Weinschel Associates	LN673		
1.4	FSV30	Signal Analyzer 10 Hz - 30 GHz	Rohde & Schwarz	103005	2018-04	2020-04
1.5	Fluke 177	Digital Multimeter 03 (Multimeter)	Fluke Europe B.V.	86670383	2018-04	2020-04
1.6	VT 4002	Climatic Chamber	Vötsch	58566002150010	2018-04	2020-04
1.7	A8455-4	4 Way Power Divider (SMA)		-		
1.8	Opus10 THI (8152.00)	ThermoHygro Datalogger 03 (Environ)	Lufft Mess- und Regeltechnik GmbH	7482	2017-03	2019-05
1.9	SMBV100A	Vector Signal Generator 9 kHz - 6 GHz	Rohde & Schwarz	259291	2016-10	2019-10
1.10	OSP120	Switching Unit with integrated power meter	Rohde & Schwarz	101158	2018-05	2021-05

- 2 Radiated Emissions
Lab to perform radiated emission tests

Ref.No.	Device Name	Description	Manufacturer	Serial Number	Last Calibration	Calibration Due
2.1	NRV-Z1	Sensor Head A	Rohde & Schwarz	827753/005	2018-07	2019-07
2.2	MFS	Rubidium Frequency Normal MFS	Datum GmbH	002	2018-10	2020-10
2.3	Opus10 TPR (8253.00)	ThermoAirpressure Datalogger 13 (Environ)	Lufft Mess- und Regeltechnik GmbH	13936	2017-04	2019-05
2.4	ESW44	EMI Test Receiver	Rohde & Schwarz	101603	2018-05	2019-05
2.5	Anechoic Chamber	10.38 x 6.38 x 6.00 m ³	Frankonia	none	2018-06	2020-06
2.6	HL 562	Ultralog new biconicals	Rohde & Schwarz	830547/003	2018-07	2021-07
2.7	5HC2700/12750 -1.5-KK	High Pass Filter	Trilithic	9942012		
2.8	ASP 1.2/1.8-10 kg	Antenna Mast	Maturo GmbH	-		

Ref.No.	Device Name	Description	Manufacturer	Serial Number	Last Calibration	Calibration Due
2.9	Fully Anechoic Room	8.80m x 4.60m x 4.05m (l x w x h)	Albatross Projects	P26971-647-001-PRB	2018-06	2020-06
2.10	Fluke 177	Digital Multimeter 03 (Multimeter)	Fluke Europe B.V.	86670383	2018-04	2020-04
2.11	JS4-18002600-32-5P	Broadband Amplifier 18 GHz - 26 GHz	Miteq	849785		
2.12	FSW 43	Spectrum Analyzer	Rohde & Schwarz	103779	2019-02	2021-02
2.13	3160-09	Standard Gain / Pyramidal Horn Antenna 26.5 GHz	EMCO Elektronik GmbH	00083069		
2.14	WHKX 7.0/18G-8SS	High Pass Filter	Wainwright	09		
2.15	4HC1600/12750-1.5-KK	High Pass Filter	Trilithic	9942011		
2.16	Chroma 6404	AC Power Source	Chroma ATE INC.	64040001304		
2.17	JS4-00102600-42-5A	Broadband Amplifier 30 MHz - 26 GHz	Miteq	619368		
2.18	TT 1.5 WI	Turn Table	Maturo GmbH	-		
2.19	HL 562 Ultralog	Log.-per. Antenna	Rohde & Schwarz	100609	2016-04	2019-04
2.20	3160-10	Standard Gain / Pyramidal Horn Antenna 40 GHz	EMCO Elektronik GmbH	00086675		
2.21	5HC3500/18000-1.2-KK	High Pass Filter	Trilithic	200035008		
2.22	Opus10 THI (8152.00)	ThermoHygro Datalogger 12 (Environ)	Lufft Mess- und Regeltechnik GmbH	12482	2017-03	2019-05
2.23	ESR 7	EMI Receiver / Spectrum Analyzer	Rohde & Schwarz	101424	2019-01	2020-01
2.24	JS4-00101800-35-5P	Broadband Amplifier 30 MHz - 18 GHz	Miteq	896037		
2.25	AS 620 P	Antenna mast	HD GmbH	620/37		
2.26	Tilt device Maturo (Rohacell)	Antrieb TD1.5-10kg	Maturo GmbH	TD1.5-10kg/024/3790709		
2.27	PAS 2.5 - 10 kg	Antenna Mast	Maturo GmbH	-		
2.28	AM 4.0	Antenna mast	Maturo GmbH	AM4.0/180/11920513		
2.29	HF 907	Double-ridged horn	Rohde & Schwarz	102444	2018-07	2021-07

3 FCC Conducted Base Station / Repeater
EN300328/301893/FCC cond. Test Lab

Ref.No.	Device Name	Description	Manufacturer	Serial Number	Last Calibration	Calibration Due
3.1	FSV40	Signal Analyzer 10 Hz - 40 GHz	Rohde & Schwarz	100886	2018-10	2019-10
3.2	SMBV100A	Vector Signal Generator 9 kHz - 6 GHz	Rohde & Schwarz	255975	2017-08	2019-08
3.3	SMBV100A	Vector Signal Generator 9 kHz - 6 GHz	Rohde & Schwarz	259291	2016-10	2019-10

The calibration interval is the time interval between "Last Calibration" and "Calibration Due"

6 ANTENNA FACTORS, CABLE LOSS AND SAMPLE CALCULATIONS

This chapter contains the antenna factors with their corresponding path loss of the used measurement path for all antennas as well as the insertion loss of the LISN.

6.1 LISN R&S ESH3-Z5 (150 KHZ – 30 MHZ)

Frequency MHz	Corr. dB	LISN insertion loss ESH3- Z5 dB	cable loss (incl. 10 dB atten- uator) dB
0.15	10.1	0.1	10.0
5	10.3	0.1	10.2
7	10.3	0.2	10.3
10	10.3	0.2	10.3
12	10.7	0.3	10.4
14	10.7	0.3	10.4
16	10.8	0.4	10.4
18	10.9	0.4	10.3
20	10.9	0.4	10.3
22	11.1	0.3	10.6
24	11.1	0.3	10.6
26	11.2	0.3	10.7
28	11.2	0.3	10.7
30	11.3	0.3	10.8

Sample calculation

$$U_{\text{LISN}} \text{ (dB } \mu\text{V)} = U \text{ (dB } \mu\text{V)} + \text{Corr. (dB)}$$

U = Receiver reading

LISN Insertion loss = Voltage Division Factor of LISN

Corr. = sum of single correction factors of used LISN, cables, switch units (if used)

Linear interpolation will be used for frequencies in between the values in the table.

6.2 ANTENNA R&S HFH2-Z2 (9 KHZ – 30 MHZ)

Frequency MHz	AF HFH-Z2) dB (1/m)	Corr. dB	cable loss 1 (inside chamber) dB	cable loss 2 (outside chamber) dB	cable loss 3 (switch unit) dB	cable loss 4 (to receiver) dB	distance corr. (-40 dB/ decade) dB	d _{Limit} (meas. distance (limit) m	d _{used} (meas. distance (used) m
0.009	20.30	-79.6	0.1	0.1	0.1	0.1	-80	300	3
0.01	20.45	-79.6	0.1	0.1	0.1	0.1	-80	300	3
0.015	20.37	-79.6	0.1	0.1	0.1	0.1	-80	300	3
0.02	20.36	-79.6	0.1	0.1	0.1	0.1	-80	300	3
0.025	20.38	-79.6	0.1	0.1	0.1	0.1	-80	300	3
0.03	20.32	-79.6	0.1	0.1	0.1	0.1	-80	300	3
0.05	20.35	-79.6	0.1	0.1	0.1	0.1	-80	300	3
0.08	20.30	-79.6	0.1	0.1	0.1	0.1	-80	300	3
0.1	20.20	-79.6	0.1	0.1	0.1	0.1	-80	300	3
0.2	20.17	-79.6	0.1	0.1	0.1	0.1	-80	300	3
0.3	20.14	-79.6	0.1	0.1	0.1	0.1	-80	300	3
0.49	20.12	-79.6	0.1	0.1	0.1	0.1	-80	300	3
0.490001	20.12	-39.6	0.1	0.1	0.1	0.1	-40	30	3
0.3	20.11	-39.6	0.1	0.1	0.1	0.1	-40	30	3
0.8	20.10	-39.6	0.1	0.1	0.1	0.1	-40	30	3
1	20.09	-39.6	0.1	0.1	0.1	0.1	-40	30	3
2	20.08	-39.6	0.1	0.1	0.1	0.1	-40	30	3
3	20.06	-39.6	0.1	0.1	0.1	0.1	-40	30	3
4	20.05	-39.5	0.2	0.1	0.1	0.1	-40	30	3
5	20.05	-39.5	0.2	0.1	0.1	0.1	-40	30	3
6	20.02	-39.5	0.2	0.1	0.1	0.1	-40	30	3
8	19.95	-39.5	0.2	0.1	0.1	0.1	-40	30	3
10	19.83	-39.4	0.2	0.1	0.2	0.1	-40	30	3
12	19.71	-39.4	0.2	0.1	0.2	0.1	-40	30	3
14	19.54	-39.4	0.2	0.1	0.2	0.1	-40	30	3
16	19.53	-39.3	0.3	0.1	0.2	0.1	-40	30	3
18	19.50	-39.3	0.3	0.1	0.2	0.1	-40	30	3
20	19.57	-39.3	0.3	0.1	0.2	0.1	-40	30	3
22	19.61	-39.3	0.3	0.1	0.2	0.1	-40	30	3
24	19.61	-39.3	0.3	0.1	0.2	0.1	-40	30	3
26	19.54	-39.3	0.3	0.1	0.2	0.1	-40	30	3
28	19.46	-39.2	0.3	0.1	0.3	0.1	-40	30	3
30	19.73	-39.1	0.4	0.1	0.3	0.1	-40	30	3

Sample calculation

$E \text{ (dB } \mu\text{V/m)} = U \text{ (dB } \mu\text{V)} + AF \text{ (dB 1/m)} + Corr. \text{ (dB)}$
 U = Receiver reading
 AF = Antenna factor
 Corr. = sum of single correction factors of used cables, switch unit, distance correction, amplifier (if applicable)
 distance correction = $-40 * \text{LOG} (d_{\text{Limit}} / d_{\text{used}})$
 Linear interpolation will be used for frequencies in between the values in the table.
 Table shows an extract of values

6.3 ANTENNA R&S HL562 (30 MHz – 1 GHz)

($d_{Limit} = 3\text{ m}$)

Frequency	AF R&S HL562	Corr.
MHz	dB (1/m)	dB
30	18.6	0.6
50	6.0	0.9
100	9.7	1.2
150	7.9	1.6
200	7.6	1.9
250	9.5	2.1
300	11.0	2.3
350	12.4	2.6
400	13.6	2.9
450	14.7	3.1
500	15.6	3.2
550	16.3	3.5
600	17.2	3.5
650	18.1	3.6
700	18.5	3.6
750	19.1	4.1
800	19.6	4.1
850	20.1	4.4
900	20.8	4.7
950	21.1	4.8
1000	21.6	4.9

cable loss 1 (inside chamber)	cable loss 2 (outside chamber)	cable loss 3 (switch unit)	cable loss 4 (to receiver)	distance corr. (-20 dB/decade)	d_{Limit} (meas. distance (limit))	d_{used} (meas. distance (used))
dB	dB	dB	dB	dB	m	m
0.29	0.04	0.23	0.02	0.0	3	3
0.39	0.09	0.32	0.08	0.0	3	3
0.36	0.14	0.47	0.08	0.0	3	3
0.73	0.20	0.39	0.12	0.0	3	3
0.84	0.21	0.70	0.11	0.0	3	3
0.98	0.24	0.80	0.13	0.0	3	3
1.04	0.26	0.89	0.15	0.0	3	3
1.18	0.31	0.96	0.13	0.0	3	3
1.28	0.35	1.03	0.19	0.0	3	3
1.39	0.38	1.11	0.22	0.0	3	3
1.44	0.39	1.20	0.19	0.0	3	3
1.55	0.46	1.24	0.23	0.0	3	3
1.59	0.43	1.29	0.23	0.0	3	3
1.67	0.34	1.35	0.22	0.0	3	3
1.67	0.42	1.41	0.15	0.0	3	3
1.87	0.34	1.46	0.25	0.0	3	3
1.90	0.46	1.51	0.25	0.0	3	3
1.99	0.60	1.56	0.27	0.0	3	3
2.14	0.60	1.63	0.29	0.0	3	3
2.22	0.60	1.66	0.33	0.0	3	3
2.23	0.61	1.71	0.30	0.0	3	3

($d_{Limit} = 10\text{ m}$)

30	18.6	-9.9
50	6.0	-9.6
100	9.7	-9.2
150	7.9	-8.8
200	7.6	-8.6
250	9.5	-8.3
300	11.0	-8.1
350	12.4	-7.9
400	13.6	-7.6
450	14.7	-7.4
500	15.6	-7.2
550	16.3	-7.0
600	17.2	-6.9
650	18.1	-6.9
700	18.5	-6.8
750	19.1	-6.3
800	19.6	-6.3
850	20.1	-6.0
900	20.8	-5.8
950	21.1	-5.6
1000	21.6	-5.6

0.29	0.04	0.23	0.02	-10.3	10	3
0.39	0.09	0.32	0.08	-10.3	10	3
0.36	0.14	0.47	0.08	-10.3	10	3
0.73	0.20	0.39	0.12	-10.3	10	3
0.84	0.21	0.70	0.11	-10.3	10	3
0.98	0.24	0.80	0.13	-10.3	10	3
1.04	0.26	0.89	0.15	-10.3	10	3
1.18	0.31	0.96	0.13	-10.3	10	3
1.28	0.35	1.03	0.19	-10.3	10	3
1.39	0.38	1.11	0.22	-10.3	10	3
1.44	0.39	1.20	0.19	-10.3	10	3
1.55	0.46	1.24	0.23	-10.3	10	3
1.59	0.43	1.29	0.23	-10.3	10	3
1.67	0.34	1.35	0.22	-10.3	10	3
1.67	0.42	1.41	0.15	-10.3	10	3
1.87	0.34	1.46	0.25	-10.3	10	3
1.90	0.46	1.51	0.25	-10.3	10	3
1.99	0.60	1.56	0.27	-10.3	10	3
2.14	0.60	1.63	0.29	-10.3	10	3
2.22	0.60	1.66	0.33	-10.3	10	3
2.23	0.61	1.71	0.30	-10.3	10	3

Sample calculation

$E\text{ (dB } \mu\text{V/m)} = U\text{ (dB } \mu\text{V)} + \text{AF (dB 1/m)} + \text{Corr. (dB)}$
 U = Receiver reading
 AF = Antenna factor
 Corr. = sum of single correction factors of used cables, switch unit, distance correction, amplifier (if applicable)
 distance correction = $-20 * \text{LOG}(d_{Limit}/d_{used})$
 Linear interpolation will be used for frequencies in between the values in the table.
 Tables show an extract of values.

6.4 ANTENNA R&S HF907 (1 GHZ – 18 GHZ)

Frequency	AF R&S HF907	Corr.
MHz	dB (1/m)	dB
1000	24.4	-19.4
2000	28.5	-17.4
3000	31.0	-16.1
4000	33.1	-14.7
5000	34.4	-13.7
6000	34.7	-12.7
7000	35.6	-11.0

cable loss 1 (relay + cable inside chamber)	cable loss 2 (outside chamber)	cable loss 3 (switch unit, attenuator & pre-amp)	cable loss 4 (to receiver)
dB	dB	dB	dB
0.99	0.31	-21.51	0.79
1.44	0.44	-20.63	1.38
1.87	0.33	-19.85	1.33
2.41	0.67	-19.13	1.31
2.78	0.86	-18.71	1.40
2.74	0.90	-17.83	1.47
2.82	0.86	-16.19	1.46

Frequency	AF R&S HF907	Corr.
MHz	dB (1/m)	dB
3000	31.0	-23.4
4000	33.1	-23.3
5000	34.4	-21.7
6000	34.7	-21.2
7000	35.6	-19.8

cable loss 1 (relay inside chamber)	cable loss 2 (inside chamber)	cable loss 3 (outside chamber)	cable loss 4 (switch unit, attenuator & pre-amp)	cable loss 5 (to receiver)	used for FCC 15.247
dB	dB	dB	dB	dB	
0.47	1.87	0.33	-27.58	1.33	
0.36	2.41	0.67	-28.23	1.31	
0.61	2.78	0.86	-27.35	1.40	
0.38	2.74	0.90	-26.89	1.47	
0.66	2.82	0.86	-25.58	1.46	

Frequency	AF R&S HF907	Corr.
MHz	dB (1/m)	dB
7000	35.6	-57.3
8000	36.3	-56.3
9000	37.1	-55.3
10000	37.5	-56.2
11000	37.5	-55.3
12000	37.6	-53.7
13000	38.2	-53.5
14000	39.9	-56.3
15000	40.9	-54.1
16000	41.3	-54.1
17000	42.8	-54.4
18000	44.2	-54.7

cable loss 1 (relay inside chamber)	cable loss 2 (High Pass)	cable loss 3 (pre-amp)	cable loss 4 (inside chamber)	cable loss 5 (outside chamber)	cable loss 6 (to receiver)
dB	dB	dB	dB	dB	dB
0.36	1.28	-62.72	2.66	0.94	1.46
0.69	0.71	-61.49	2.84	1.00	1.53
0.68	0.65	-60.80	3.06	1.09	1.60
0.70	0.34	-61.91	3.28	1.20	1.67
0.80	0.61	-61.40	3.43	1.27	1.70
0.84	0.42	-59.70	3.53	1.26	1.73
0.83	0.44	-59.81	3.75	1.32	1.83
0.91	0.33	-63.03	3.91	1.40	1.77
0.98	0.34	-61.05	4.02	1.44	1.83
1.23	0.49	-61.51	4.17	1.51	1.85
1.36	0.76	-62.36	4.34	1.53	2.00
1.70	0.33	-62.88	4.41	1.55	1.91

Sample calculation

$E \text{ (dB } \mu\text{V/m)} = U \text{ (dB } \mu\text{V)} + AF \text{ (dB 1/m)} + Corr. \text{ (dB)}$
 U = Receiver reading
 AF = Antenna factor
 Corr. = sum of single correction factors of used cables, switch unit, distance correction, amplifier (if applicable)
 Linear interpolation will be used for frequencies in between the values in the table.
 Tables show an extract of values.

6.5 ANTENNA EMCO 3160-09 (18 GHZ – 26.5 GHZ)

Frequency	AF EMCO 3160-09	Corr.
MHz	dB (1/m)	dB
18000	40.2	-23.5
18500	40.2	-23.2
19000	40.2	-22.0
19500	40.3	-21.3
20000	40.3	-20.3
20500	40.3	-19.9
21000	40.3	-19.1
21500	40.3	-19.1
22000	40.3	-18.7
22500	40.4	-19.0
23000	40.4	-19.5
23500	40.4	-19.3
24000	40.4	-19.8
24500	40.4	-19.5
25000	40.4	-19.3
25500	40.3	-20.4
26000	40.3	-21.3
26500	40.3	-21.1

cable loss 1 (inside chamber)	cable loss 2 (pre- amp)	cable loss 3 (inside chamber)	cable loss 4 (switch unit)	cable loss 5 (to receiver)
dB	dB	dB	dB	dB
0.72	-35.85	6.20	2.81	2.65
0.69	-35.71	6.46	2.76	2.59
0.76	-35.44	6.69	3.15	2.79
0.74	-35.07	7.04	3.11	2.91
0.72	-34.49	7.30	3.07	3.05
0.78	-34.46	7.48	3.12	3.15
0.87	-34.07	7.61	3.20	3.33
0.90	-33.96	7.47	3.28	3.19
0.89	-33.57	7.34	3.35	3.28
0.87	-33.66	7.06	3.75	2.94
0.88	-33.75	6.92	3.77	2.70
0.90	-33.35	6.99	3.52	2.66
0.88	-33.99	6.88	3.88	2.58
0.91	-33.89	7.01	3.93	2.51
0.88	-33.00	6.72	3.96	2.14
0.89	-34.07	6.90	3.66	2.22
0.86	-35.11	7.02	3.69	2.28
0.90	-35.20	7.15	3.91	2.36

Sample calculation

$$E \text{ (dB } \mu\text{V/m)} = U \text{ (dB } \mu\text{V)} + \text{AF (dB 1/m)} + \text{Corr. (dB)}$$

U = Receiver reading

AF = Antenna factor

Corr. = sum of single correction factors of used cables, switch unit, distance correction, amplifier (if applicable)

Linear interpolation will be used for frequencies in between the values in the table.

Table shows an extract of values.

6.6 ANTENNA EMCO 3160-10 (26.5 GHZ – 40 GHZ)

Frequency GHz	AF EMCO 3160-10 dB (1/m)	Corr. dB	cable loss 1 (inside chamber) dB	cable loss 2 (outside chamber) dB	cable loss 3 (switch unit) dB	cable loss 4 (to receiver) dB	distance corr. (-20 dB/ decade) dB	d _{Limit} (meas. distance (limit) m	d _{used} (meas. distance (used) m
26.5	43.4	-11.2	4.4				-9.6	3	1.0
27.0	43.4	-11.2	4.4				-9.6	3	1.0
28.0	43.4	-11.1	4.5				-9.6	3	1.0
29.0	43.5	-11.0	4.6				-9.6	3	1.0
30.0	43.5	-10.9	4.7				-9.6	3	1.0
31.0	43.5	-10.8	4.7				-9.6	3	1.0
32.0	43.5	-10.7	4.8				-9.6	3	1.0
33.0	43.6	-10.7	4.9				-9.6	3	1.0
34.0	43.6	-10.6	5.0				-9.6	3	1.0
35.0	43.6	-10.3	5.1				-9.6	3	1.0
36.0	43.6	-10.4	5.1				-9.6	3	1.0
37.0	43.7	-10.3	5.2				-9.6	3	1.0
38.0	43.7	-10.2	5.3				-9.6	3	1.0
39.0	43.7	-10.2	5.4				-9.6	3	1.0
40.0	43.8	-10.1	5.5				-9.6	3	1.0

Sample calculation

$$E \text{ (dB } \mu\text{V/m)} = U \text{ (dB } \mu\text{V)} + AF \text{ (dB 1/m)} + Corr. \text{ (dB)}$$

U = Receiver reading

AF = Antenna factor

Corr. = sum of single correction factors of used cables, switch unit, distance correction, amplifier (if applicable)

Linear interpolation will be used for frequencies in between the values in the table.

distance correction = $-20 * \text{LOG} (d_{\text{Limit}} / d_{\text{used}})$

Linear interpolation will be used for frequencies in between the values in the table.

Table shows an extract of values.

7 MEASUREMENT UNCERTAINTIES

Test Case(s)	Parameter	Uncertainty
- Field strength of spurious radiation	Power	± 5.5 dB
- Out-of-band rejection - Occupied Bandwidth - Input versus output spectrum	Power Frequency	± 2.9 dB ± 11.2 kHz
- Effective radiated power, mean output power and zone enhancer gain - Peak to Average Ratio	Power	± 2.2 dB
- Out-of-band emission limits - Conducted Spurious Emissions at Antenna Terminal	Power Frequency	± 2.2 dB ± 11.2 kHz

8 PHOTO REPORT

Please see separate photo report.