

Test Site:
FCC Test Site No.:
IC OATS No.:

96997
IC3475A-1



**BUREAU
VERITAS**

ECL-EMC Test Report No.: 12-229

Equipment under test: ION-M17P/19HP 1700MHz Path
FCC ID: XS5-M17P19HP
Type of test: **FCC 47 CFR Part 27 Subpart C: 2012**
Miscellaneous Wireless Communication Services

Measurement Procedures: 47 CFR Parts 2 2011 (*Frequency Allocations and Radio Treaty Matters; General Rules and Regulations*), Part 27:2011 (*Miscellaneous Wireless Communication Services*), ANSI/TIA-603-C (2004), *Land Mobile FM or PM Communications Equipment Measurement and Performance Standards*

Test result: **Passed**

Date of issue:	29.11.12		Signature:
Issue-No.:	01	Author:	
Date of delivery:	14.05.12	Checked:	
Test dates:	01.04.11 – 28.11.12		
Pages:	36		

Test Report No.: 12-229

FCC ID: XS5- M717P

IC ID: 2237E- M717P



BUREAU
VERITAS

Manufacturer: ANDREW Wireless Systems GmbH
Industriering 10

D-86675 Buchdorf

Tel.: +49 (0)9099 69 0

Fax: +49 (0)9099 69 140

Test Location: Bureau Veritas Consumer Products Services
Germany GmbH
European Compliance Laboratory (ECL)
Thurn-und-Taxis-Straße 18

D-90411 Nürnberg

Tel.: +49 40 74041 0

Fax: +49 40 74041-2755

General:

The purpose of this report is to show compliance to the FCC regulations for devices operating under Part N 22,N°27 of the Code of Federal Regulations title 47.

This report informs about the results of the EMC tests, it only refers to the equipment under test. No part of this report may be reproduced in any form, without written permission.



Table of contents

1	TEST RESULTS SUMMARY	5
2	EQUIPMENT UNDER TEST (E.U.T.)	6
2.1	DESCRIPTION	6
2.1.1	DOWNLINK	6
2.1.2	UPLINK	6
2.1.3	DESCRIPTION OF EUT	6
2.1.4	BLOCK DIAGRAM OF MEASUREMENT REFERENCE POINTS	7
2.1.5	DOWNLINK SYSTEM GAIN AND OUTPUT POWER	7
3	TEST SITE (ANDREW BUCHDORF)	8
3.1	TEST ENVIRONMENT	8
3.2	TEST EQUIPMENT	8
3.3	INPUT AND OUTPUT LOSSES	9
3.4	MEASUREMENT UNCERTAINTY	9
4	TEST SITE (TEMPTON SERVICE PLUS GMBH)	10
5	RF POWER OUT: FCC §27.50, §2.1046	11
5.1	LIMIT	11
5.2	TEST METHOD	11
5.3	TEST RESULTS	12
5.3.1	DOWNLINK	12
5.3.1.1	CDMA	13
5.3.1.2	W-CDMA	13
5.3.1.3	LTE	14
5.3.2	UPLINK	14
5.4	SUMMARY TEST RESULT	14
6	OCCUPIED BANDWIDTH: FCC §2.1049; RSS-GEN	15
6.1	LIMIT	15
6.2	TEST METHOD	15
6.3	TEST RESULTS	15
6.3.1	DOWNLINK	15
6.3.1.1	CDMA	16
6.3.1.2	W-CDMA	17
6.3.1.3	LTE	18
6.3.2	UPLINK	19
6.4	SUMMARY TEST RESULT	19
7	SPURIOUS EMISSIONS AT ANTENNA TERMINALS: FCC §27.53, §2.1051	20
7.1	LIMIT	20
7.2	TEST METHOD	20
7.3	TEST RESULTS	21
7.3.1	DOWNLINK	21
7.3.1.1	WCDMA < 1MHz to band edge	22



7.3.1.2	CDMA < 1MHz to band edge.....	23
7.3.1.3	LTE < 1MHz to band edge.....	24
7.3.1.4	CDMA > 1MHz to band edge.....	25
7.3.1.5	W-CDMA > 1MHz to band edge.....	26
7.3.1.6	LTE > 1MHz to band edge.....	26
7.3.2	UPLINK.....	27
7.4	SUMMARY TEST RESULT.....	27
8	FIELD STRENGTH OF SPURIOUS EMISSIONS: §27.53, §2.1053, RSS-139.....	28
8.1	METHOD OF MEASUREMENT.....	31
8.2	LIMIT §27.53 (H).....	31
8.3	CLIMATIC VALUES IN THE LAB.....	31
8.4	TEST RESULTS.....	32
8.4.1	30 MHz TO 1 GHz DOWNLINK (BOTTOM – MIDDLE – TOP).....	32
8.4.2	30 MHz TO 1 GHz DOWNLINK (MIDDLE OF ALL PATHS).....	33
8.4.3	1 GHz TO 22 GHz DOWNLINK (BOTTOM – MIDDLE – TOP).....	34
8.4.4	1 GHz TO 22 GHz DOWNLINK (MIDDLE OF ALL PATHS).....	35
9	HISTORY.....	35

Test Report No.: 12-229

FCC ID: XS5- M717P

IC ID: 2237E- M717P



**BUREAU
VERITAS**

1 Test Results Summary

Name of Test	FCC Para. No.	FCC Method	FCC Spec.	Result
RF Power Output	27.50(d)	2.1046	1640 Watts/MHz	Complies
Occupied Bandwidth	2.1049	2.1049	Input/Output	Complies
Spurious Emissions at Antenna Terminals	27.53(h)	2.1051	-13dBm	Complies
Field Strength of Spurious Emissions	27.53(m)	2.1053 TIA/EA-603	-13dBm E.I.R.P	Complies
Frequency Stability	27.54	2.1055	Must stay in band	NA

Frequency stability is not applicable because the device uses a common oscillator to up convert and down convert the RF signal. The EUT does not contain modulation circuitry, or frequency generation, therefore the test was not performed.



2 Equipment under test (E.U.T.)

2.1 Description

Kind of equipment	ION-M17P/19HP
Andrew Ident. Number	7616968-0001
Serial no.(SN)	12
Revision	00
Software version and ID	V5.5.2 7162793
Type of modulation and Designator	CDMA (F9W) <input checked="" type="checkbox"/> W-CDMA (F9W) <input checked="" type="checkbox"/> LTE (G7D) <input checked="" type="checkbox"/>
Frequency Translation	F1-F1 <input checked="" type="checkbox"/> F1-F2 <input type="checkbox"/> N/A <input type="checkbox"/>
Band Selection	Software <input type="checkbox"/> Duplexer <input checked="" type="checkbox"/> Full band <input type="checkbox"/>

2.1.1 Downlink

Pass band	2110 MHz – 2155 MHz
Max. composite output power based on one carrier per path (rated)	43,00 dBm = 19,95 W
Gain	10 dB @ Pout BTS of 33 dBm

2.1.2 Uplink

Pass band	1710 MHz – 1755 MHz
Gain	n.a.

Note: The EUT does not transmit over the air in the uplink direction.

2.1.3 Description of EUT

ION-M17P/19P is a multi-band, multi-operator remote unit with various extension units. It is used in conjunction with a Master Unit in the ION optical distribution system.

The ION-M17P/19P Repeater consists of one 1700 MHz path and one 1900 MHz path, with the intended use of simultaneous transmission

This Test Report describes the approval of the ION-M17P 1700 MHz path.



2.1.4 Block diagram of measurement reference points

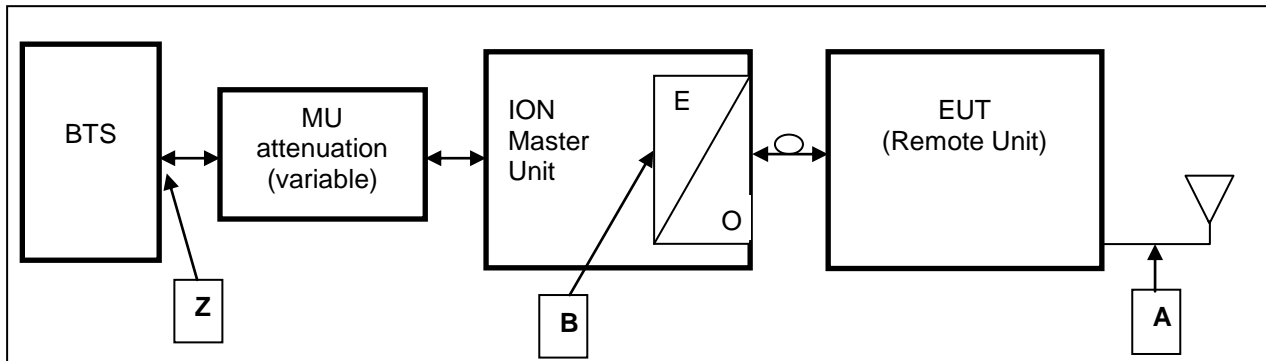

figure 2.1.4-#1 Block diagram of measurement reference points

Remote Unit is the EUT

O/E Optical / Electrical converter
 SRMU Sub Rack Master Unit

Reference point A SRMU UL output, DL input
 Reference point B Remote Unit DL output, UL input
 Reference point Z BTS DL output, UL input

Downlink: Measure from reference point B to A

Since a signal generator does not supply a good output signal with +33 or +43dBm, for the downlink measurement the MU Attenuation is not used.

That means for downlink measurements the signal generator is connected to measurement point A at the master optical / electrical converter and the analyzer to the measurement point B at the RU.

2.1.5 Downlink System Gain and Output Power

System optimized for BTS power (fixed value) Z	MU Attenuation (manual leveling)	Maximum rated input power at the MU OTRX (fixed value) B	RU Gain (fixed value) B to A	Maximum rated output power at RU Antenna port (fixed value) A
+33 dBm	30 dB	3dBm	+40 dB	+43 dBm @ 1 carrier
System Gain Z to A	+10dB			
+43 dBm	40 dB	3dBm	+40 dB	+43 dBm @ 1 carrier
System Gain Z to A	+0dB			

table 2.1.5-#1 Equipment under test (E.U.T.) Description Downlink System Gain and Output Power

Test Report No.: 12-229

FCC ID: XS5- M717P

IC ID: 2237E- M717P



**BUREAU
VERITAS**

3 Test site (Andrew Buchdorf)

3.1 Test environment

All tests were performed under the following environmental conditions:

Condition	Minimum value	Maximum value
Barometric pressure	86 kPa	106 kPa
Temperature	15°C	30°C
Relative Humidity	20 %	75 %
Power supply range	±5% of rated voltages	

3.2 Test equipment

Andrew Inv. No.	Test equipment	Type	Manufacturer	Serial No.	Calibration
8741	Network Analyzer	ZVRE	R&S	100034	02/2013
8961	Spectrum Analyzer	FSP	R&S		07/2012
9069	Generator	SMBV100A	Agilent		08/2012
9123	Generator	SMBV100A	R&S		11/2012
8375	Universal Counter	53132A	Agilent		07/2012
8667	Power Meter	E4418A	Agilent	GB38273230	04/2013
8668	Power Sensor	E8481H	Agilent	US3318A19208	04/2013
7355	Power Amplifier	3-Band Amp	Andrew	---	CIU
7157	RF-Cable	Succoflex	Suhner	36180/4P	CIU
7158	RF-Cable	Succoflex	Suhner	36182/4P	CIU
7289	RF-Cable	Succoflex	Suhner	28443/4PE	CIU
7290	RF-Cable	Succoflex	Suhner	28444/4PE	CIU
7385	RF-Cable	Succoflex	Suhner	36267/4P	CIU
7387	RF-Cable	Succoflex	Suhner	36267/4P	CIU
7390	RF-Cable	Succoflex	Suhner	40193/4P	CIU
7381	RF-Cable	Succoflex	Suhner	40200/4P	CIU
7384	RF-Cable	Succoflex	Suhner	40448/4P	CIU
7294	RF-Cable	Succoflex	Suhner	40448/4P	CIU
7382	RF-Cable	Succoflex	Suhner	40221/4P	CIU
7160	Divider	SMP 317	Mikom	784	CIU

CIU = Calibrate in use

Test Report No.: 12-229

FCC ID: XS5- M717P

IC ID: 2237E- M717P



**BUREAU
VERITAS**

3.3 Input and output losses

All recorded power levels should be referenced to the input and output connectors of the repeater, unless explicitly stated otherwise.

The test equipment used in this test has to be calibrated, so that the functionality is also checked.

All cables, attenuators, splitter, isolator, circulator and combiner etc. must be measured before testing and used for compensation during testing.

3.4 Measurement uncertainty

The extended measurement uncertainty corresponds to the measurement results from the standard measurement uncertainty multiplied by the coverage factor $k=2$. The true value is located in the corresponding interval with a probability of 95 %.

Test Report No.: 12-229

FCC ID: XS5- M717P

IC ID: 2237E- M717P



BUREAU
VERITAS

4 Test site (TEMPTON Service Plus GmbH)

FCC Test site:

IC OATS:

See relevant dates under section 8.



5 RF Power Out: FCC §27.50, §2.1046

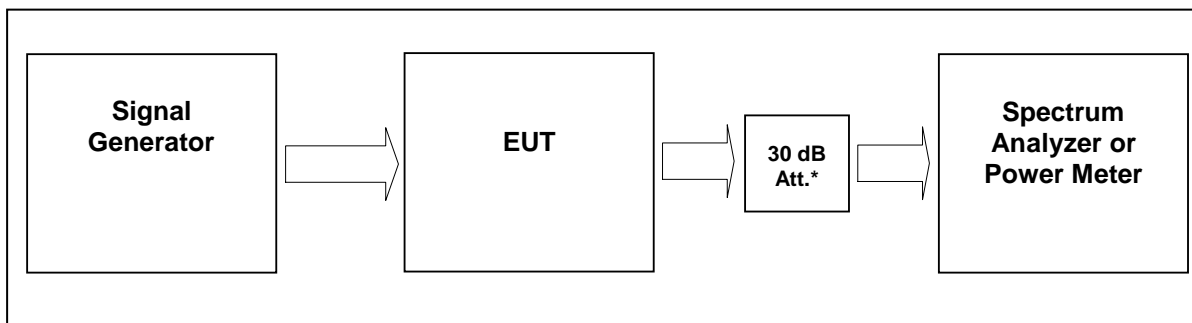

figure 3.4-#1 Test setup: RF Power Out: FCC §27.50, §2.1046

Measurement uncertainty	± 0,38 dB
Test equipment used	8890; 8667; 8668; 8848; 7355;

5.1 Limit

Minimum standard:

Para. No.27.50(d)(2)(B)

(d) The following power and antenna height requirements apply to stations transmitting in the 1710–1755 MHz and 2110–2155 MHz bands:

(2) The power of each fixed or base station transmitting in the 2110–2155 MHz band and situated in any geographic location other than that described in paragraph (d)(1) is limited to:

(B) an EIRP of 1640 watts/MHz when transmitting with an emission bandwidth greater than 1 MHz.

5.2 Test method

§ 2.1046 Measurements required: RF power output.

(a) For transmitters other than single sideband, independent sideband and controlled carrier radiotelephone, power output shall be measured at the RF output terminals when the transmitter is adjusted in accordance with the tune-up procedure to give the values of current and voltage on the circuit elements specified in § 2.1033(c)(8). The electrical characteristics of the radio frequency load attached to the output terminals when this test is made shall be stated.

(c) For measurements conducted pursuant to paragraphs (a) and (b) of this section, all calculations and methods used by the applicant for determining carrier power or peak envelope power, as appropriate, on the basis of measured power in the radio frequency load attached to the transmitter output terminals shall be shown. Under the test conditions specified, no components of the emission spectrum shall exceed the limits specified in the applicable rule parts as necessary for meeting occupied bandwidth or emission limitations



5.3 Test results

Detector RMS.

Test signal CDMA

Signal waveform according to table 6.2-1 of standard specification 3GPP2 C.p0051-0 v1.0 16.February 2006 pilot, sync, paging, 37 traffics, which is equal to the table 6.5.2.1 of 3GPP2 C.S0010-C v2.0 24.February 2006.

Test signal WCDMA

Signal waveform according to Test Model 1 of standard specification 3GPP TS25.141. Signal modulated with a combination of PCCPCH, SCCPCH and Dedicated Physical Channels specified as test model 1 64 DPCH.

Test signal LTE:

Signal waveform according to Test Model 1.1, E-TM1.1, clause 6.1.1.1-1, table 6.1.1.1-1 of standard specification 3GPP TS 36.141 V9.3.0 (2010-03).

5.3.1 Downlink

Modulation	Measured at	RBW VBW Span	RF Power (dBm)	RF Power (W)	Plot -
CDMA	2132,5 MHz	3MHz 10MHz 15MHz	43,14	20,61	5.3.1.1 #1
WCDMA	2132,5 MHz	10MHz 10MHz 50MHz	43,01	20,00	5.3.1.2 #1
LTE	2132,5 MHz	3MHz 10MHz 50MHz	43,04	20,14	5.3.1.3 #1
Maximum output power = 43,14 dBm -> 20,61W					
Limit Maximum output power (eirp) = 1640 W					

table 5.3.1-#1 RF Power Out: FCC §27.50, §2.1046 Test results Downlink

The max RF Power out is 43.0 dBm, so the maximum antenna gain (x) can be calculated as follow:

Limit = 1000W (erp) = 60 dBm

Info: 1000W (erp) = 1640W (eirp)

60 dBm > 43.1 dBm + x

60 dBm - 43,1 dBm = 16.9 dBd

16.9 dBd + 2.15 dB = 19,09 dBi > x

=> The antenna that will use for the complete system have to have a gain lower than 19.1 dBi, relative to a dipol.

Modulation	Pin / dBm (Ref. point B)
CDMA	2,9
WCDMA	3,0
LTE	3,0

table 5.3.1-#2 RF Power Out: FCC §27.50, §2.1046 Test results Downlink Input power



5.3.1.1 CDMA

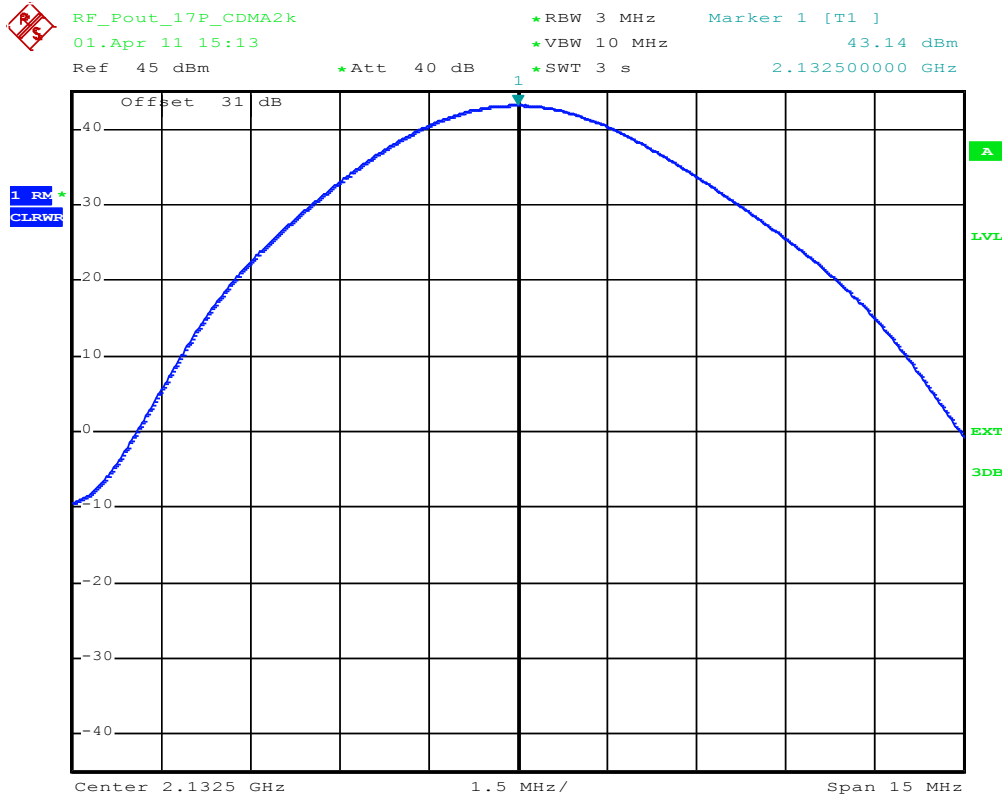

plot 5.3.1.1-#1 RF Power Out: FCC §27.50, §2.1046; Test results; Downlink; CDMA Middle

5.3.1.2 W-CDMA

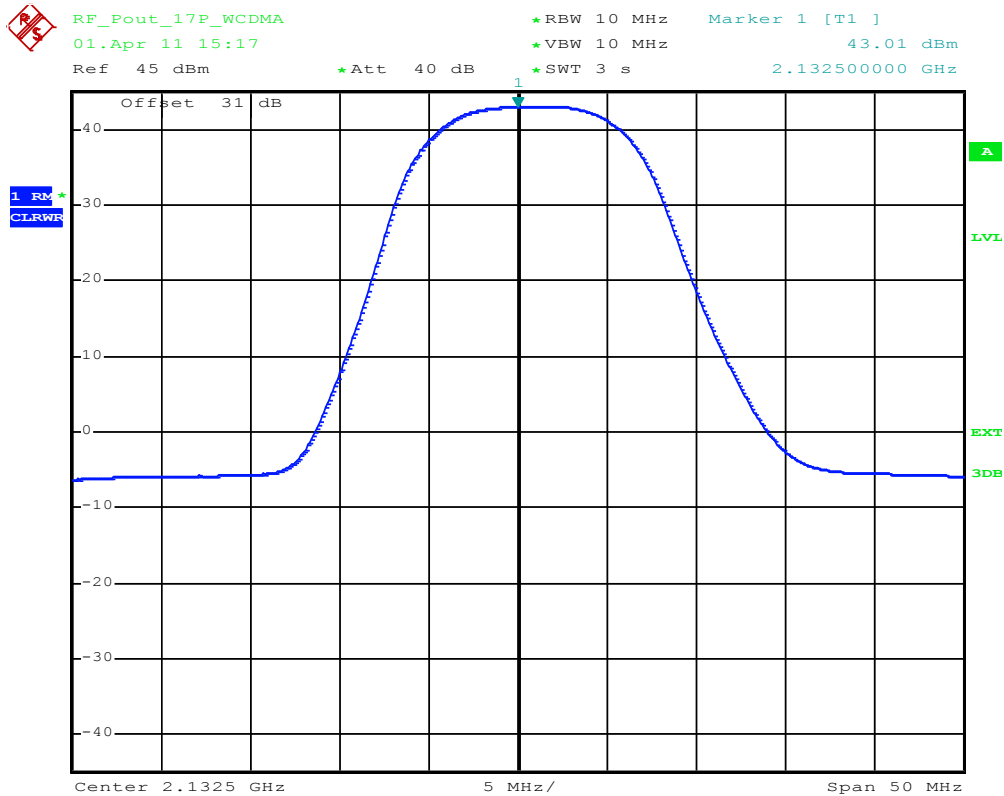

plot 5.3.1.2-#1 RF Power Out: FCC §27.50, §2.1046; Test results; Downlink; W-CDMA Middle



5.3.1.3 LTE

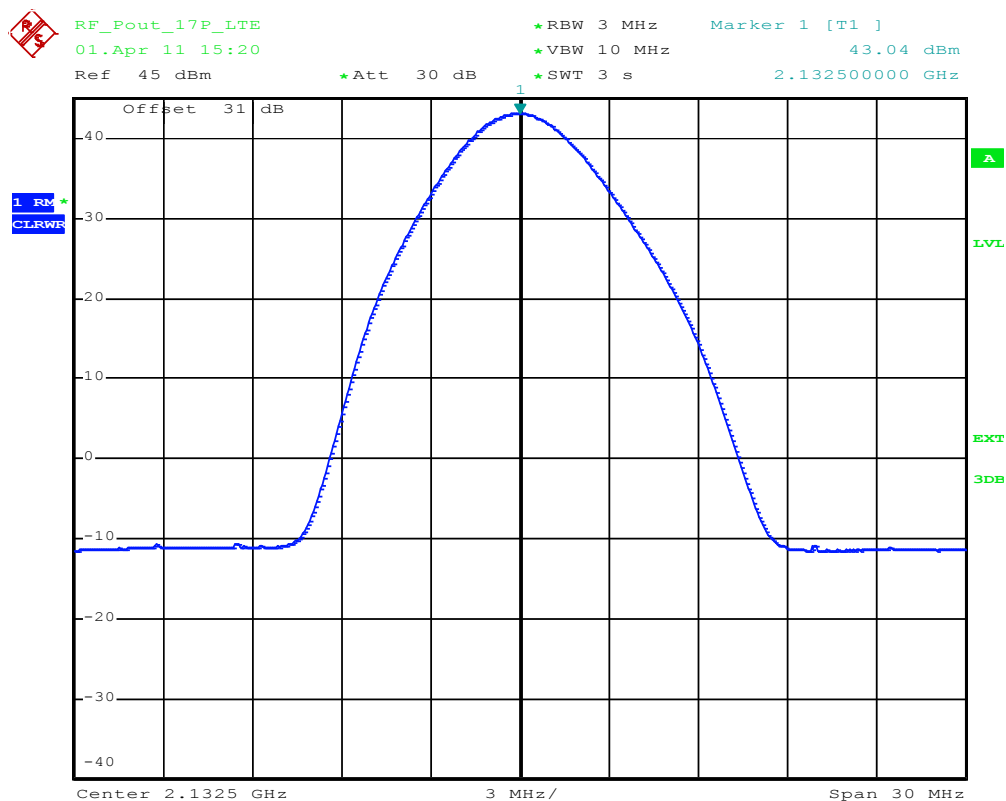

plot 5.3.1.3-#1 RF Power Out: FCC §27.50, §2.1046; Test results; Downlink; LTE Middle

5.3.2 Uplink

n.a.

Note: The EUT does not transmit over the air in the uplink direction.

5.4 Summary test result

Test result	complies, according the plots above
Tested by:	L.Oskerko
Date:	01.04.2011



6 Occupied Bandwidth: FCC §2.1049; RSS-GEN

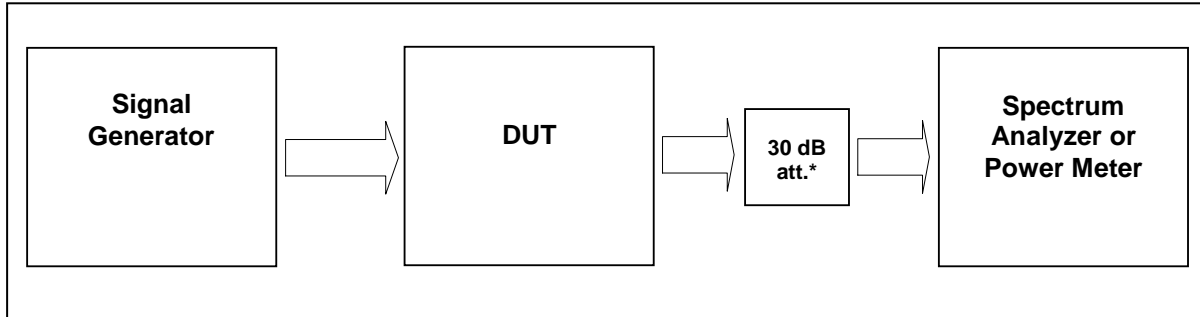

figure 5.4-#1 Test setup: Occupied Bandwidth: FCC §2.1049; RSS-GEN

Measurement uncertainty	± 0,38 dB
Test equipment used	8890; 8667; 8668; 8848; 7355;

6.1 Limit

The spectral shape of the output should look similar to input for all modulations.

6.2 Test method

Para. No.2.1049

The occupied bandwidth, that is the frequency bandwidth such that, below its lower and above its upper frequency limits, the mean powers radiated are each equal to 0.5 percent of the total mean power radiated by a given emission shall be measured under the following conditions as applicable:

(h) Transmitters employing digital modulation techniques—when modulated by an input signal such that its amplitude and symbol rate represent the maximum rated conditions under which the equipment will be operated. The signal shall be applied through any filter networks, pseudo-random generators or other devices required in normal service. Additionally, the occupied bandwidth shall be shown for operation with any devices used for modifying the spectrum when such devices are optional at the discretion of the user.

6.3 Test results

6.3.1 Downlink

Detector RMS.

Modulation	Measured at	Fcenter / MHz	RBW VBW Span	Occupied Bandwidth / MHz	Plot #
CDMA	Middle	2132,5	30kHz 300kHz 5MHz	1,24	6.3.1.1 #1, #2
WCDMA	Middle	2132,5	100kHz 1MHz 10MHz	4,17	6.3.1.2 #1, #2
LTE	Middle	2132,5	30 kHz 300 kHz 5 MHz	1,10	6.3.1.3 #1,#2

table 6.3-#1 Occupied Bandwidth: FCC §2.1049; RSS-GEN Test results Downlink



6.3.1.1 CDMA

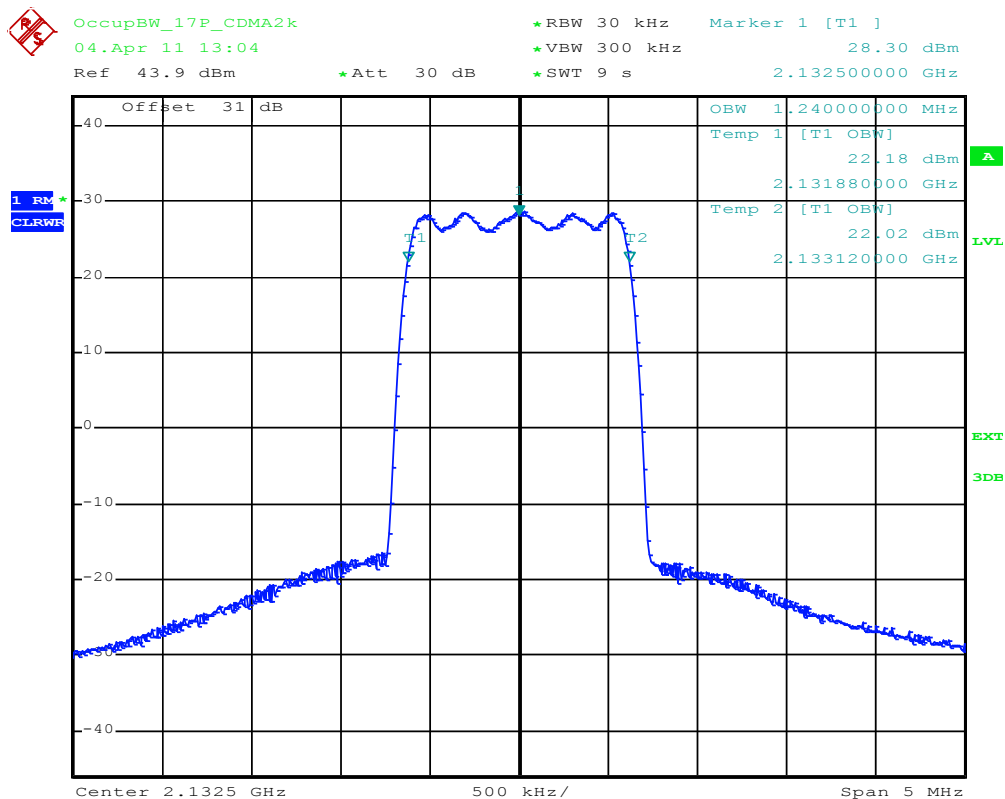

plot 6.3.1.1-#1 Occupied Bandwidth: FCC §2.1049; RSS-GEN; Test results; Downlink; CDMA Output

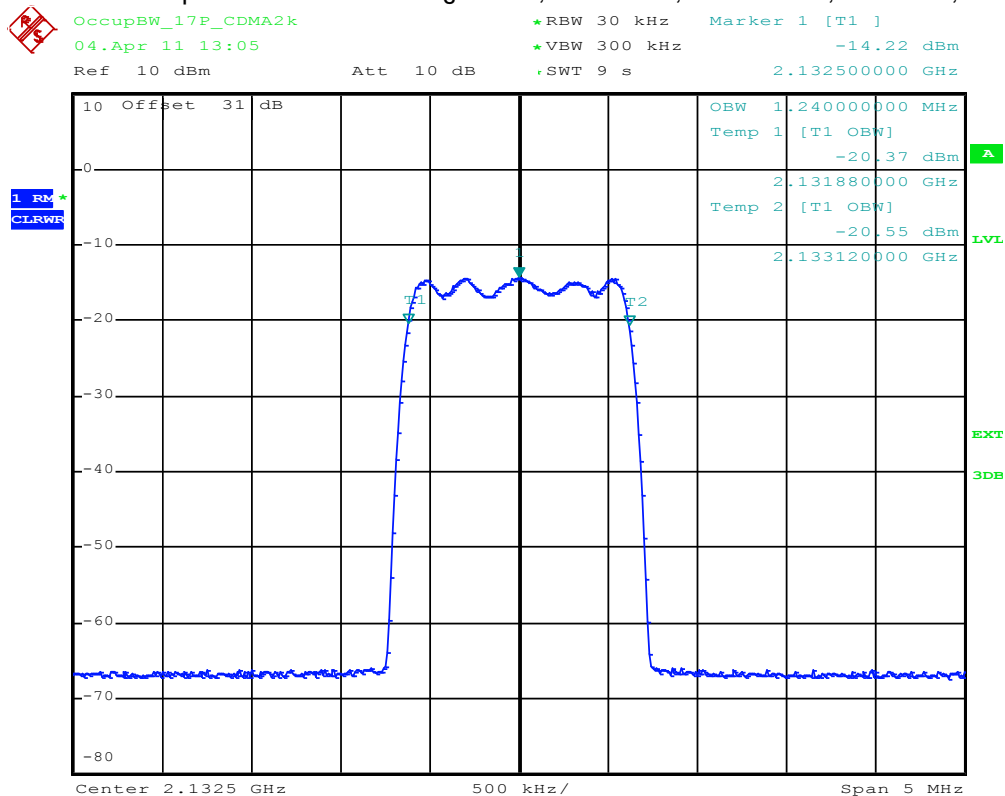

plot 6.3.1.1-#2 Occupied Bandwidth: FCC §2.1049; RSS-GEN; Test results; Downlink; CDMA Input



6.3.1.2 W-CDMA

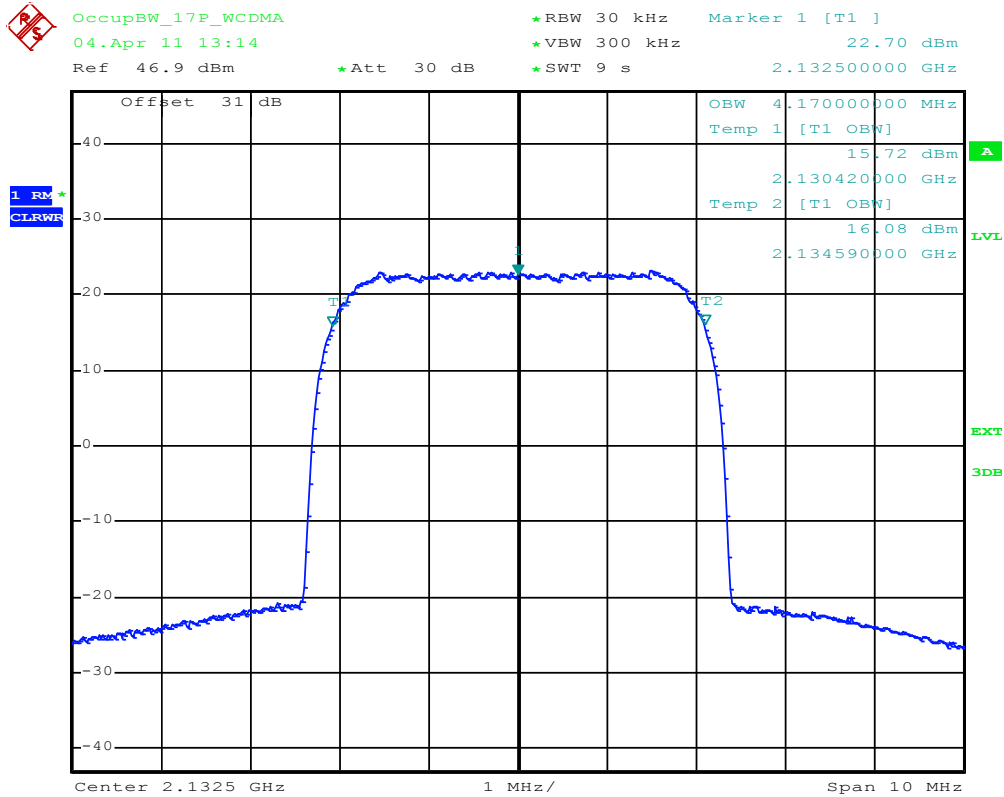

plot 6.3.1.2-#1 Occupied Bandwidth: FCC §2.1049; RSS-GEN; Test results; Downlink; W-CDMA Output

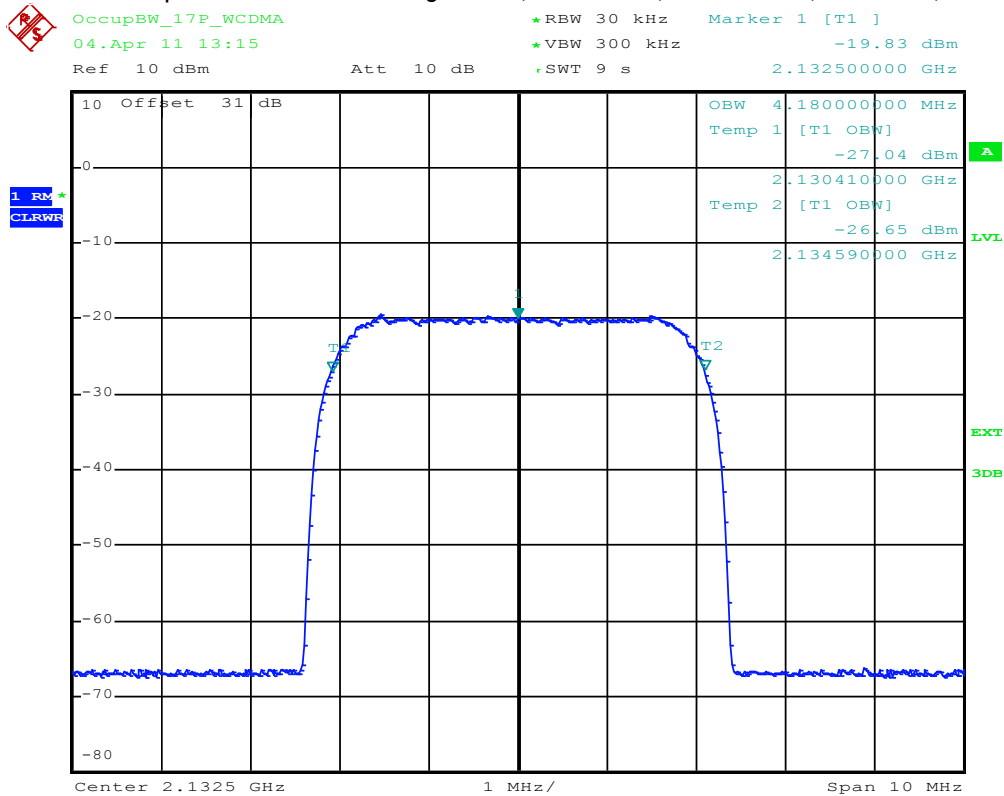

plot 6.3.1.2-#2 Occupied Bandwidth: FCC §2.1049; RSS-GEN; Test results; Downlink; W-CDMA Input



6.3.1.3 LTE

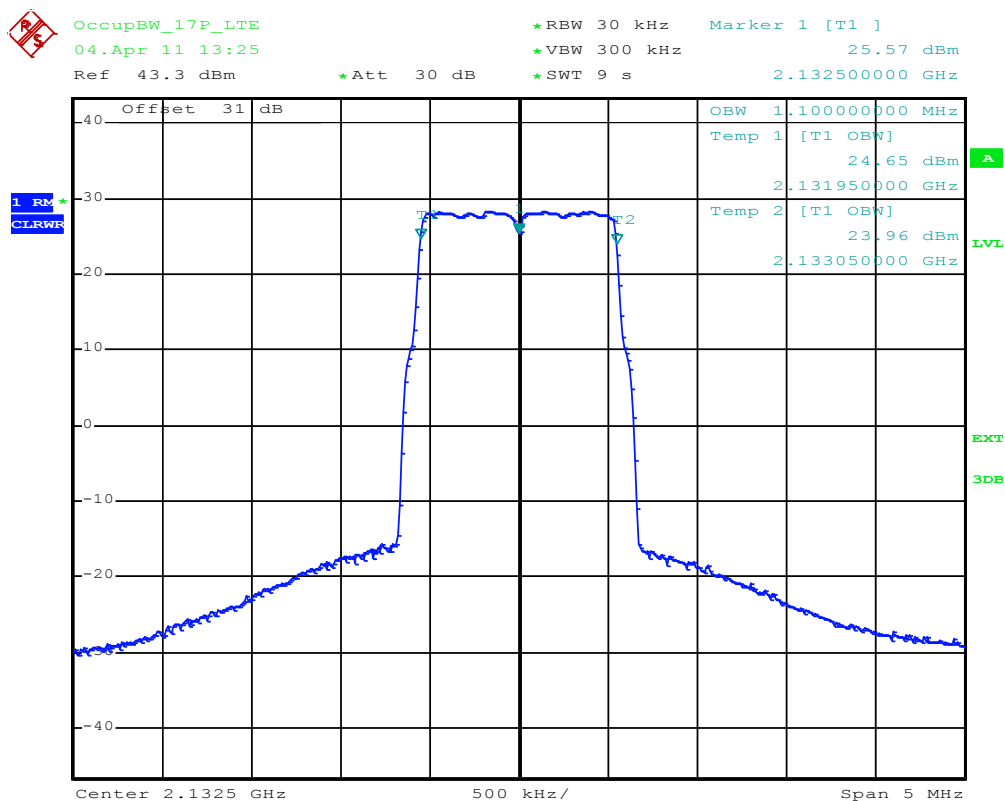

plot 6.3.1.3-#1 Occupied Bandwidth: FCC §2.1049; RSS-GEN; Test results; Downlink; LTE Output

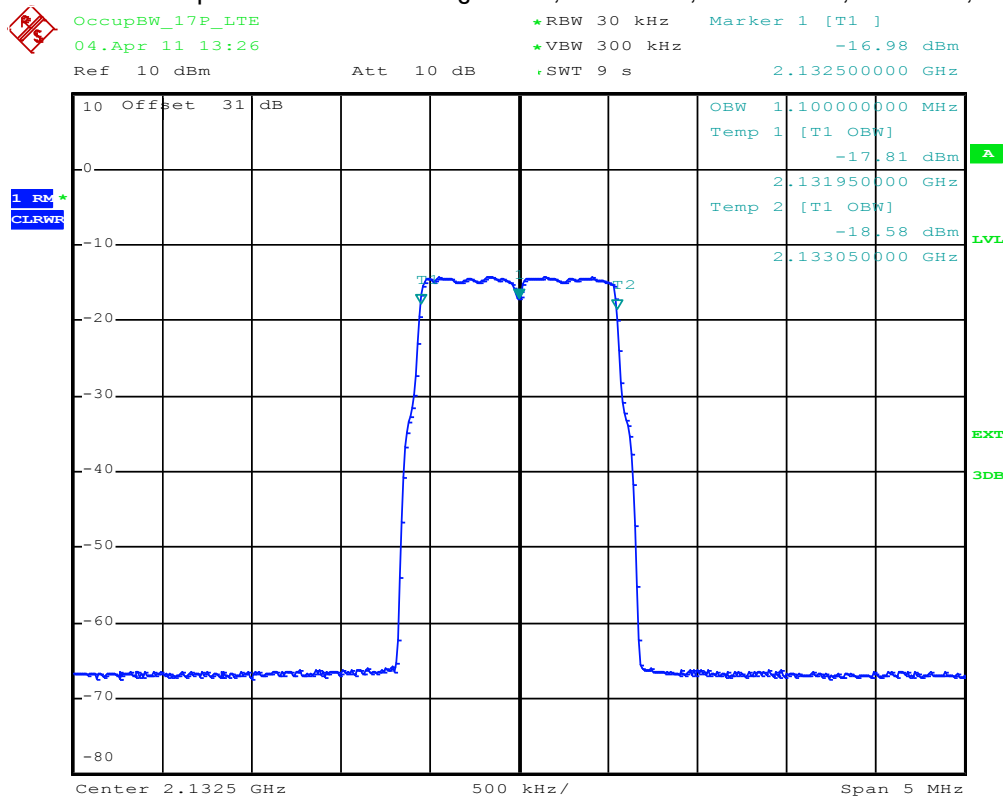

plot 6.3.1.3-#2 Occupied Bandwidth: FCC §2.1049; RSS-GEN; Test results; Downlink; LTE Input

Test Report No.: 12-229

FCC ID: XS5- M717P

IC ID: 2237E- M717P



**BUREAU
VERITAS**

6.3.2 Uplink

n.a.

Note: The EUT does not transmit over the air in the uplink direction.

6.4 Summary test result

Test result	complies, according the plots above
Tested by:	L. Oskerko
Date:	04.04.2011



7 Spurious Emissions at Antenna Terminals: FCC §27.53, §2.1051

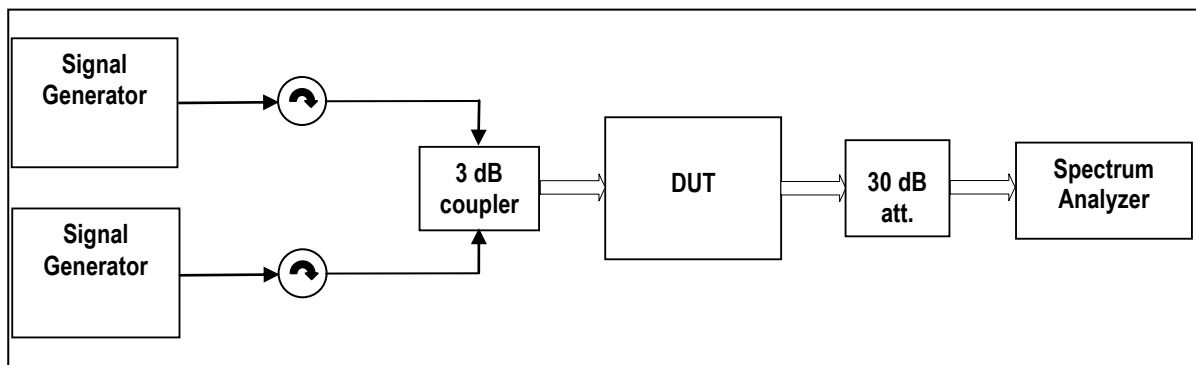

figure 7-#1 Test setup: Spurious Emissions at Antenna Terminals: FCC §27.53, §2.1051

Measurement uncertainty	± 0,54 dB ± 1,2 dB ± 1,5 dB	9 kHz to 3 GHz 3 GHz to 7 GHz 7 GHz to 26 GHz
Test equipment used	8890; 8667; 8668; 8848; 7355; 9126, 9069, 8667, 8668, 7406	

7.1 Limit

Minimum standard:

Para. No.27.53(h)

(h) For operations in the 1710–1755 MHz and 2110–2155 MHz bands, the power of any emission outside a licensee’s frequency block shall be attenuated below the transmitter power (P) by at least $43 + 10 \log_{10}(P)$ dB.

(1) Compliance with this provision is based on the use of measurement instrumentation employing a resolution bandwidth of 1 megahertz or greater. However, in the 1 megahertz bands immediately outside and adjacent to the licensee’s frequency block, a resolution bandwidth of at least one percent of the emission bandwidth of the fundamental emission of the transmitter may be employed. The emission bandwidth is defined as the width of the signal between two points, one below the carrier center frequency and one above the carrier center frequency, outside of which all emissions are attenuated at least 26 dB below the transmitter power.

(2) When measuring the emission limits, the nominal carrier frequency shall be adjusted as close to the licensee’s frequency block edges, both upper and lower, as the design permits.

(3) The measurements of emission power can be expressed in peak or average values, provided they are expressed in the same parameters as the transmitter power.

7.2 Test method

Para. No 2.1051 Measurements required: Spurious emissions at antenna terminals.

The radio frequency voltage or powers generated within the equipment and appearing on a spurious frequency shall be checked at the equipment output terminals when properly loaded with a suitable artificial antenna. Curves or equivalent data shall show the magnitude of each harmonic and other spurious emission that can be detected when the equipment is operated under the conditions specified in § 2.1049 as appropriate. The magnitude of spurious emissions which are attenuated more than 20 dB below the permissible value need not be specified.

[39 FR 5919, Feb. 15, 1974. Redesignated and amended at 63 FR 36599, July 7, 1998]



7.3 Test results

7.3.1 Downlink

<1MHz from Band Edge

Detector: RMS.

Modulation	Measured at Band Edge	Carriers	RBW VBW Span	Max. level (dBm)	Plot -
CDMA	Lower Edge Upper Edge	2110,775 MHz 2112,025 MHz 2152,975 MHz 2154,225 MHz	30kHz 300kHz 6MHz	-19,86	7.3.1.1 #1 #2
WCDMA	Lower Edge Upper Edge	2112,6 MHz 2117,6 MHz 2147,4 MHz 2152,4 MHz	100kHz 1MHz 15MHz	-24,44	7.3.1.2 #1 #2
LTE	Lower Edge Upper Edge	2110,7 MHz 2112,1 MHz 2152,9 MHz 2154,3 MHz	30kHz 300kHz 6MHz	-18,47	7.3.1.3 #1 #2

table 7.3-#1 Spurious Emissions at Antenna Terminals: FCC §27.53, §2.1051 Test results Downlink <1MHz from Band Edge

>1MHz from Band Edge

Detector: RMS.

Modulation	Carrier at	Carrier	RBW VBW Frequency range	Max. level (dBm)	Plot -
CDMA	Middle	2132,5 MHz	1MHz 3MHz 30MHz – 22GHz	< -45	7.3.1.4 #1
WCDMA	Middle	2132,5 MHz	1MHz 3MHz 30MHz – 22GHz	< -45	7.3.1.5 #1
LTE	Middle	2132,5 MHz	1MHz 3MHz 30MHz – 22GHz	< -45	7.3.1.6 #1

table 7.3-#2 Spurious Emissions at Antenna Terminals: FCC §27.53, §2.1051 Test results Downlink >1MHz from Band Edge



7.3.1.1 WCDMA < 1MHz to band edge

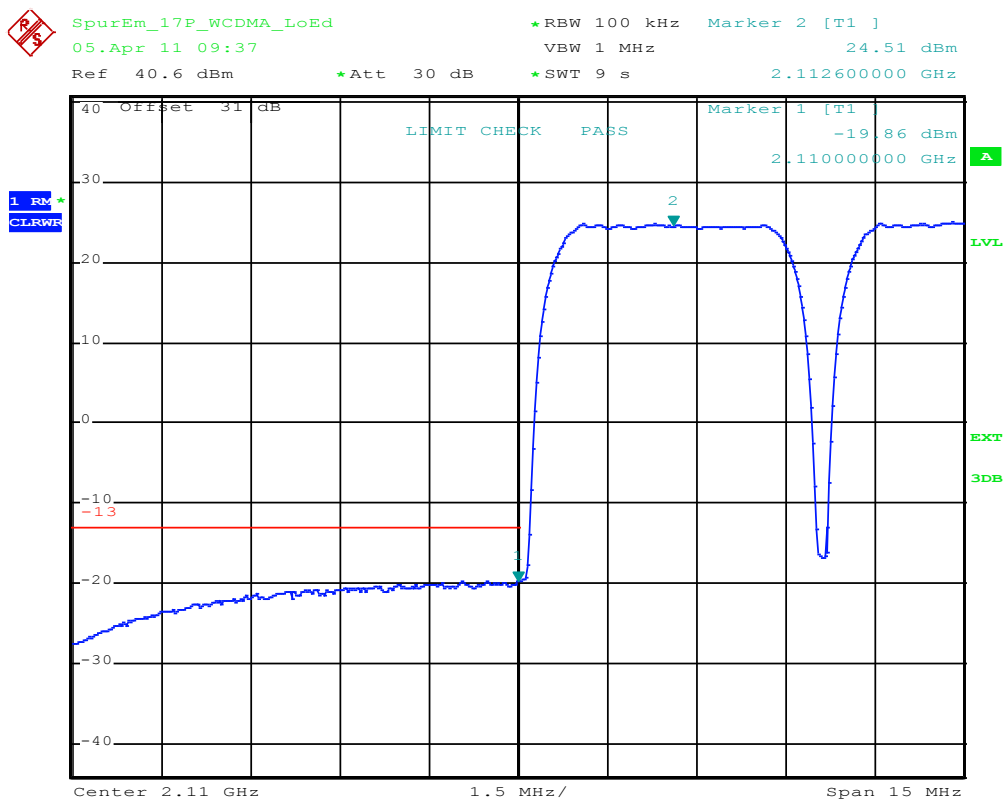

plot 7.3.1.1-#1 Spurious Emissions at Antenna Terminals: FCC §27.53, §2.1051; Test results; Downlink; WCDMA < 1MHz to band edge Lower Band Edge

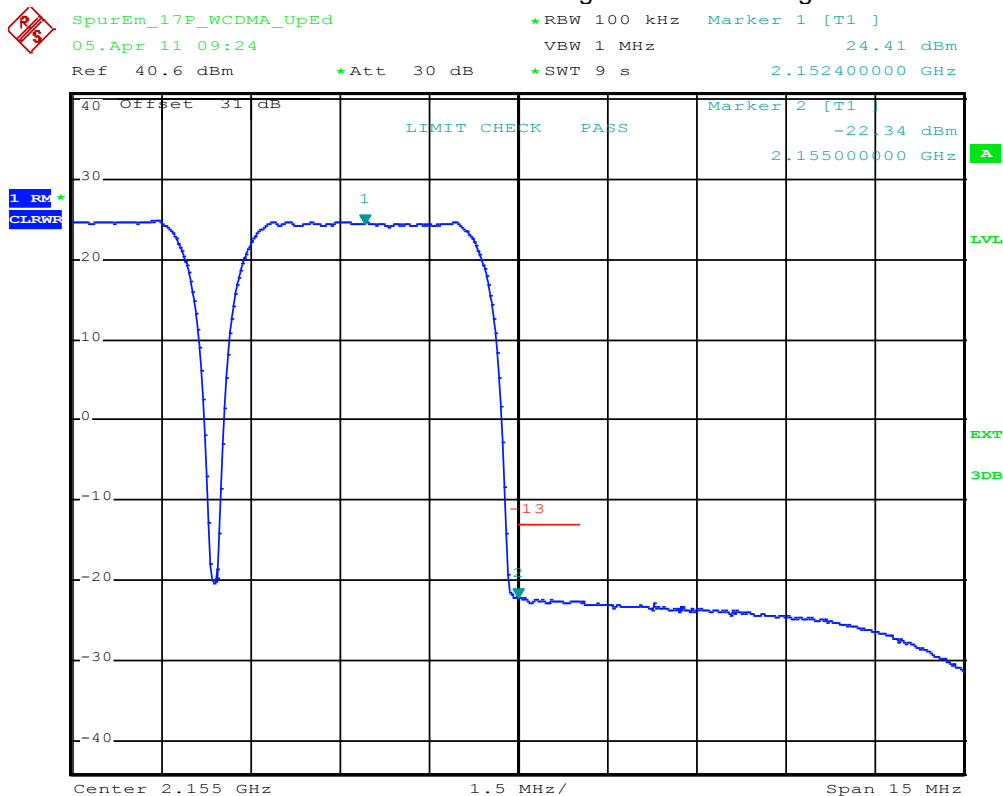

plot 7.3.1.1-#2 Spurious Emissions at Antenna Terminals: FCC §27.53, §2.1051; Test results; Downlink; WCDMA < 1MHz to band edge Upper Band Edge



7.3.1.2 CDMA < 1MHz to band edge

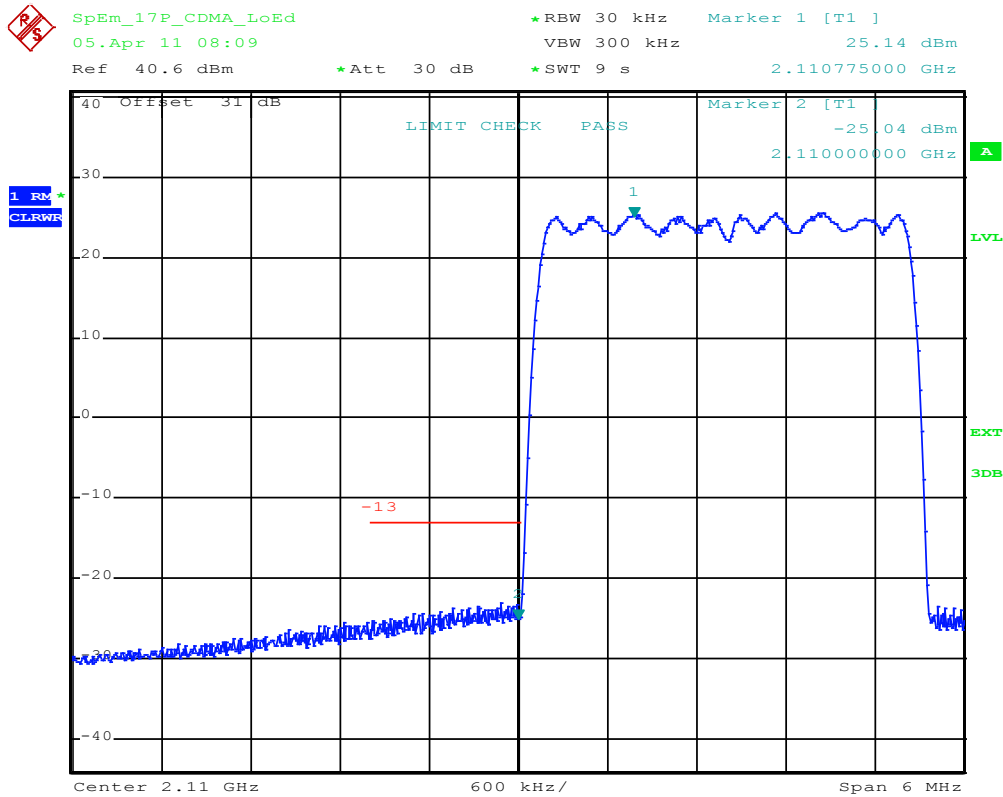

plot 7.3.1.2-#1 Spurious Emissions at Antenna Terminals: FCC §27.53, §2.1051; Test results; Downlink; CDMA < 1MHz to band edge Lower Band Edge

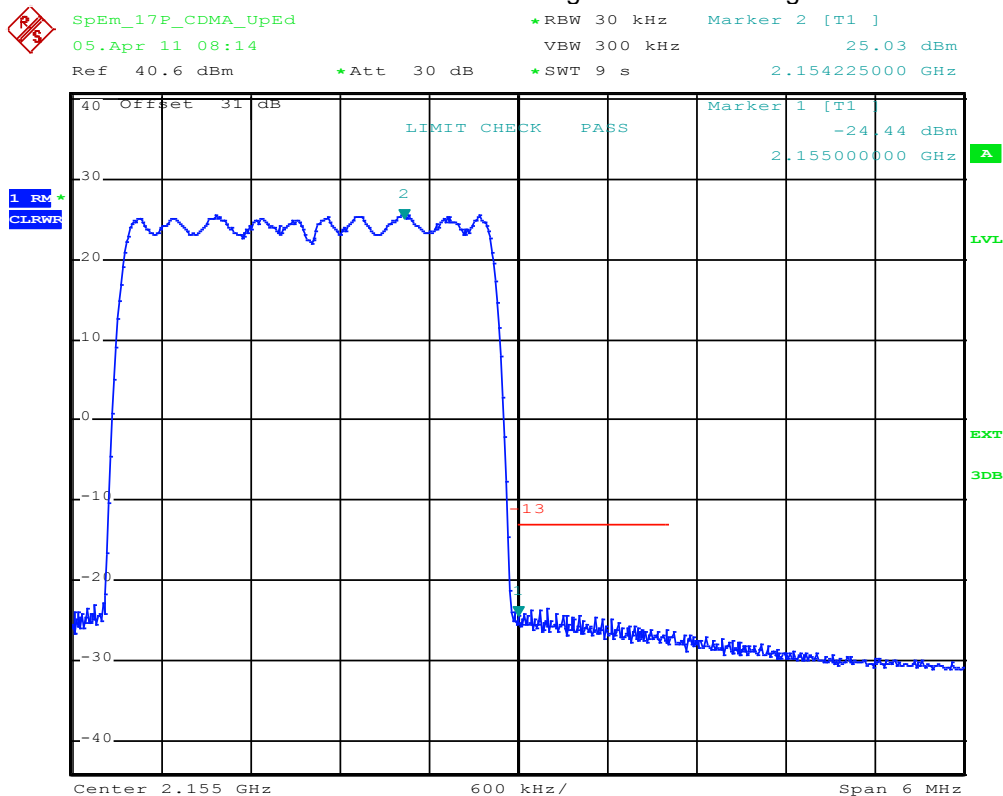

plot 7.3.1.2-#2 Spurious Emissions at Antenna Terminals: FCC §27.53, §2.1051; Test results; Downlink; CDMA < 1MHz to band edge Upper Band Edge



7.3.1.3 LTE < 1MHz to band edge

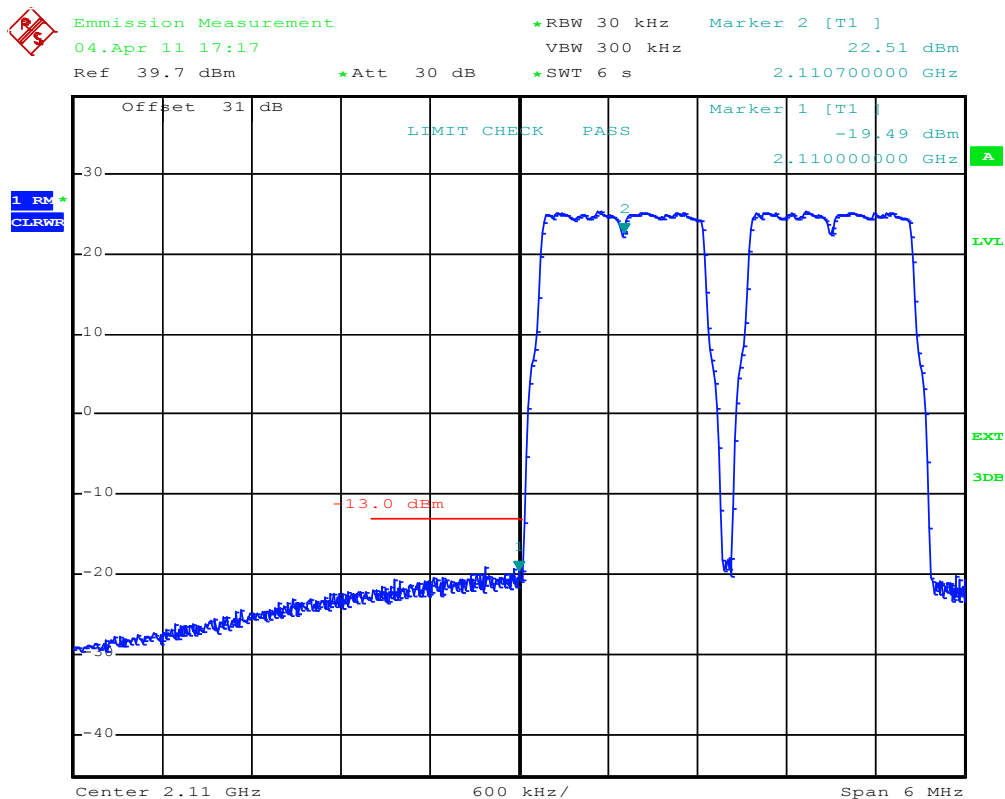

plot 7.3.1.3-#1 Spurious Emissions at Antenna Terminals: FCC §27.53, §2.1051; Test results; Downlink; LTE < 1MHz to band edge Lower Band Edge

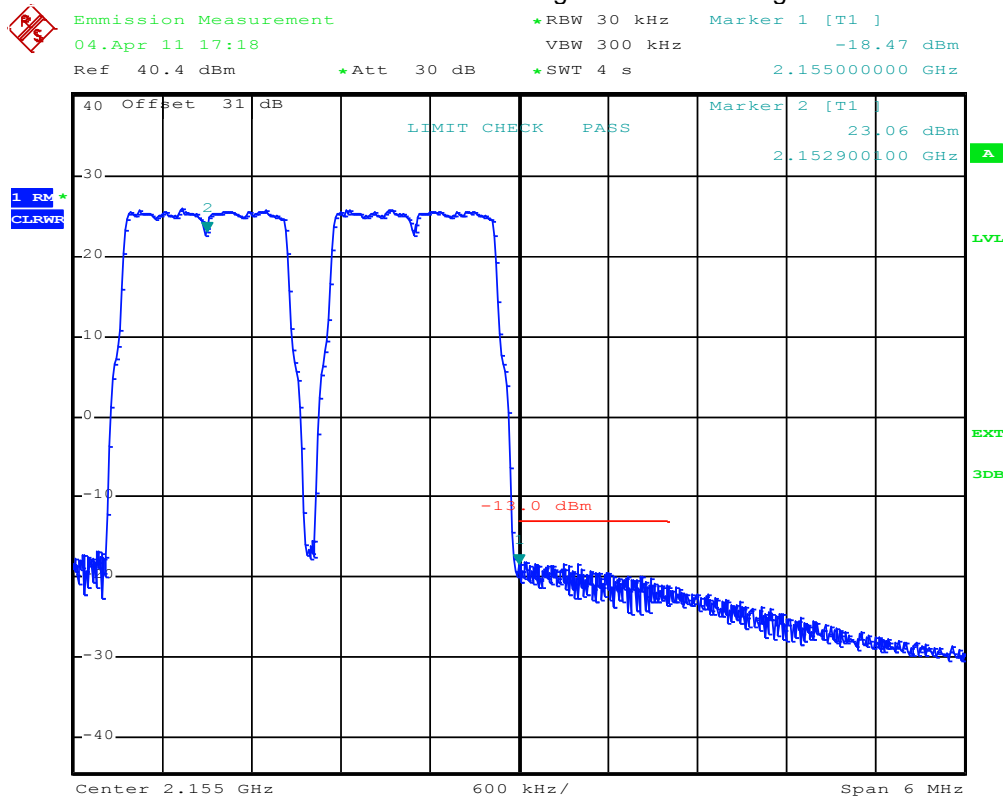

plot 7.3.1.3-#2 Spurious Emissions at Antenna Terminals: FCC §27.53, §2.1051; Test results; Downlink; LTE < 1MHz to band edge Upper Band Edge



7.3.1.4 CDMA > 1MHz to band edge

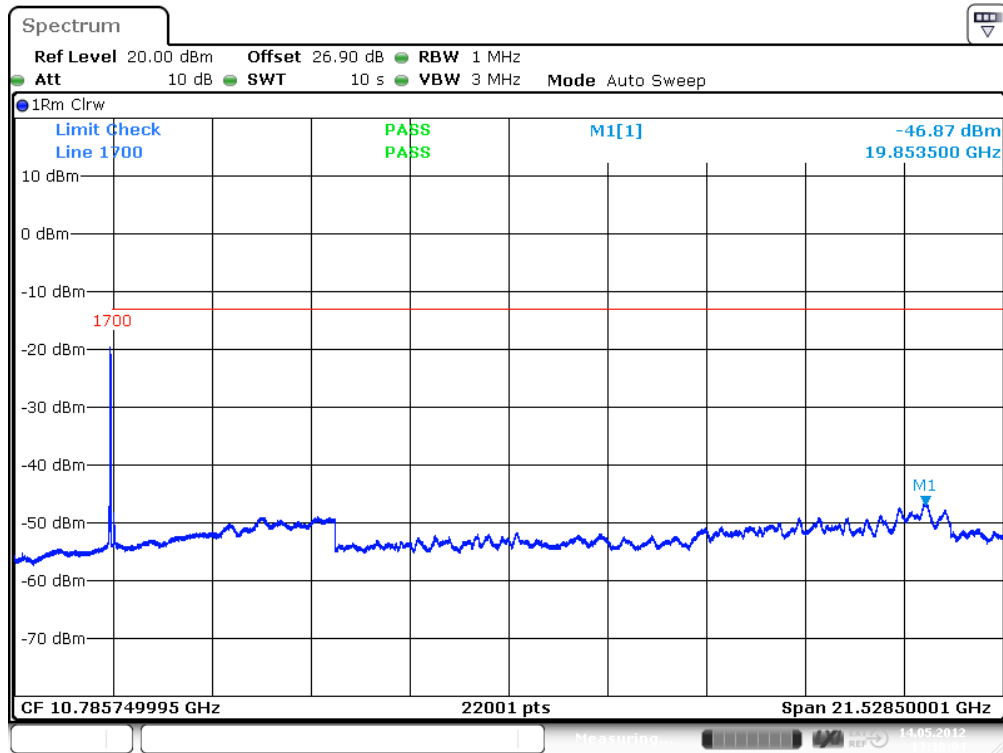

Date: 14.MAY.2012 13:18:04

plot 7.3.1.4-#1 Spurious Emissions at Antenna Terminals: FCC §27.53, §2.1051; Test results; Downlink; CDMA > 1MHz to band edge; carrier (2132,5MHz) notched



7.3.1.5 W-CDMA > 1MHz to band edge

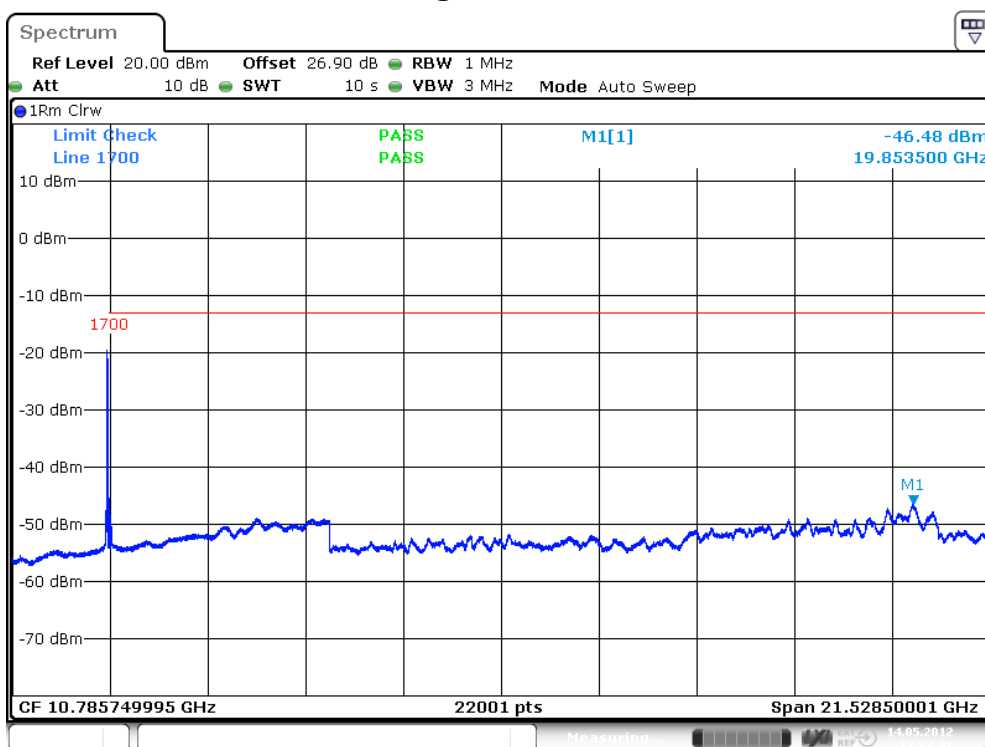

Date: 14.MAY.2012 13:22:02

plot 7.3.1.5-#1 Spurious Emissions at Antenna Terminals: FCC §27.53, §2.1051; Test results; Downlink; W-CDMA > 1MHz to band edge; carrier (2132,5MHz) notched

7.3.1.6 LTE > 1MHz to band edge

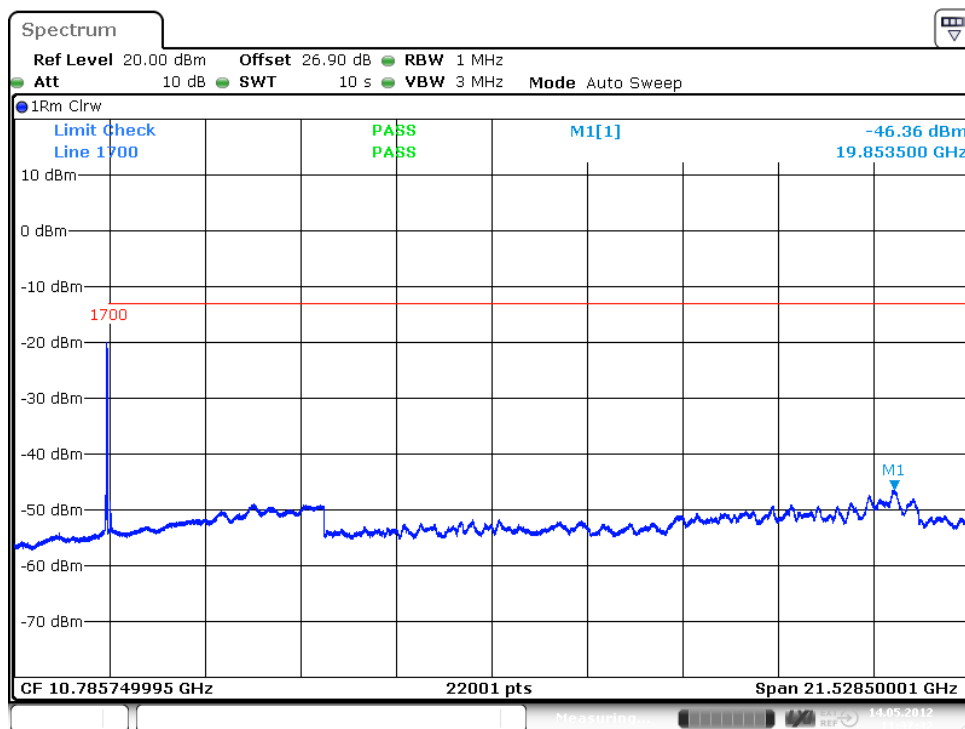

Date: 14.MAY.2012 11:37:32

plot 7.3.1.6-#1 Spurious Emissions at Antenna Terminals: FCC §27.53, §2.1051; Test results; Downlink; LTE > 1MHz to band edge; carrier (2132,5MHz) notched

Test Report No.: 12-229

FCC ID: XS5- M717P

IC ID: 2237E- M717P



**BUREAU
VERITAS**

7.3.2 Uplink

n.a.

Note: The EUT does not transmit over the air in the uplink direction.

7.4 Summary test result

Test result	complies, according the plots above
Tested by:	L.Oskerko / W. Meir
Date:	05.04.2011 / 14.05.2012

8 Field Strength of Spurious Emissions: §27.53, §2.1053, RSS-139

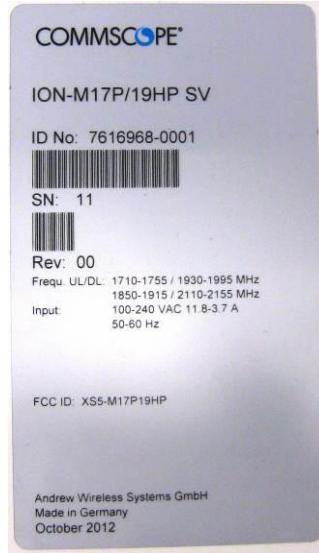

picture 8.1: Name plate

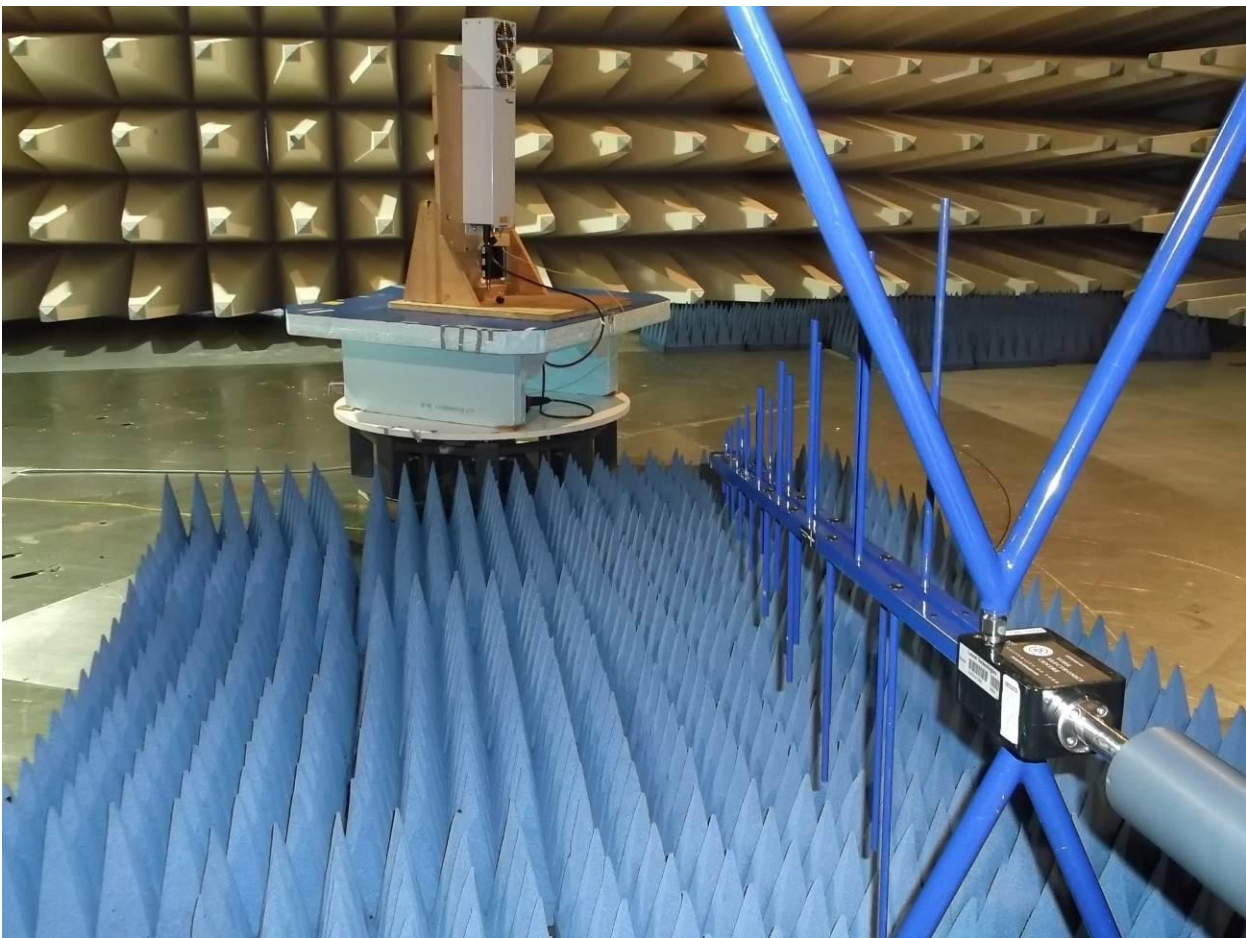

picture 8.2: Test setup: Field Strength Emission <1 GHz @3m in the SAC

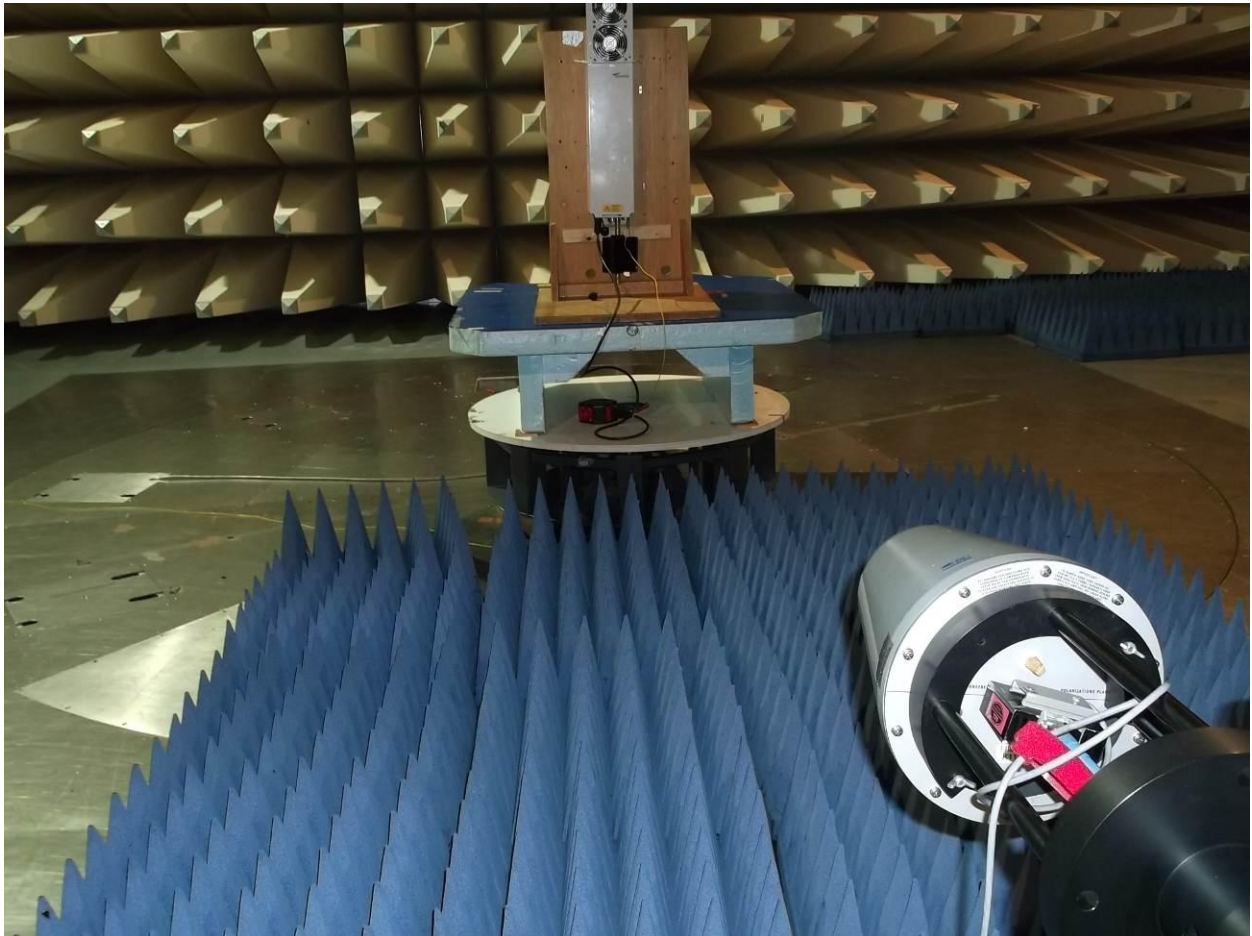

picture 8.3: Test setup: Field Strength Emission 1GHz to 22GHz @3m in the SAC

Test Report No.: 12-229

FCC ID: XS5- M717P

IC ID: 2237E- M717P



**BUREAU
VERITAS**

This clause specifies requirements for the measurement of radiated emission.

Frequency range	Distance: EUT <-> antenna / location	Limit	Test method
30 MHz - 1 GHz	3 metres / SAC	FCC 47 CFR Part 27.53	TIA/EIA-603-C:2004
1 GHz – 22 GHz		IC RSS-139 sec. 6.4	
		FCC 47 CFR Part 27.53	
		IC RSS-139 sec. 6.4	

Test equipment used:

Designation	Type	Manufacturer	Invent.-no.	Cal.-date	due Cal.- date	used
EMI test receiver	ESI40	Rohde & Schwarz	E1687	22.12.2011	22.12.2012	X
Antenna	CBL 6111	Chase	K1149	10.05.2012	10.05.2013	X
Antenna	HL 025	R&S	K809	16.11.2012	16.11.2013	X
Preamplifier	AFS4-00102000	Miteq	K838	05.06.2012	05.06.2013	X
RF Cable	Sucoflex 100	Suhner	K1742	23.05.2012	23.05.2013	X

The REMI version 2.135 has been used for max search.

Test set-up:

Test location: FAC
The Fully Anechoic Chamber (FAC) fulfils the requirements of ANSI C63.4 and CISPR 16-1-4 with regards to NSA and SVSWR.

Test Voltage: 115V / 60 Hz
Type of EUT: Wall mounted

Measurement uncertainty:

Measurement uncertainty expanded (95% or K=2)	$\pm 4,7$ dB for ANSI C63.4 measurement $\pm 0,5$ dB for TIA-603 measurement
--	---

8.1 Method of Measurement

Measurement procedure. TIA-603-C

The antenna substitution method is used to determine the equivalent radiated power at spurious frequencies. The spurious emissions are measured at a distance of 3 meters. The EUT is then replaced with a reference substitution antenna with a known gain referenced to a dipole. This antenna is fed with a signal at the spurious frequency. The level of the signal is adjusted to repeat the previously measured level. The resulting eirp is the signal level fed to the reference antenna corrected for gain referenced to an isotropic dipole (see Figure 7.2).

From KDB (AMPLIFIER, BOOSTER, AND REPEATER REMINDER SHEET):

Radiated spurs (enclosure) – Use of CW signal (low, mid. and high freq.) is acceptable rather than all modulations.

The maximum RFI field strength was determined during the measurement by rotating the turntable (± 180 degrees) and varying the height of the receive antenna ($h = 1 \dots 4$ m) as like defined in ANSI C63.4. A measurement receiver has been used with a RBW 120 kHz up to 1 GHz and 1 MHz above 1 GHz. Steps with during pre measurement was half the RBW.

Both, the Fully Anechoic Chamber (FAC) and the Semi Anechoic Chamber (SAC) fulfil the requirements of ANSI C63.4 and CISPR 16-1-4 with regards to NSA and SVSWR.

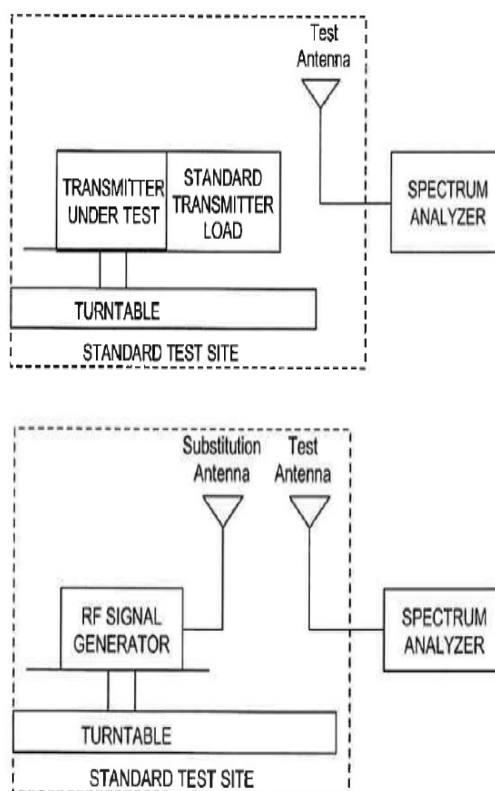

Figure #7.2 Substitution methods TIA/EIA-603-C

8.2 Limit §27.53 (h)

The Emission limit is -13dBm.

8.3 Climatic values in the lab

Temperature: 21°
 Relative Humidity: 45%
 Air-pressure: 1004 hPa



8.4 Test results

8.4.1 30 MHz to 1 GHz Downlink (Bottom – Middle – Top)

B/M/T: 2110 MHz / 2132,5 MHz / 2155 MHz (Operation with maximum composite power)

Horizontal / Vertical

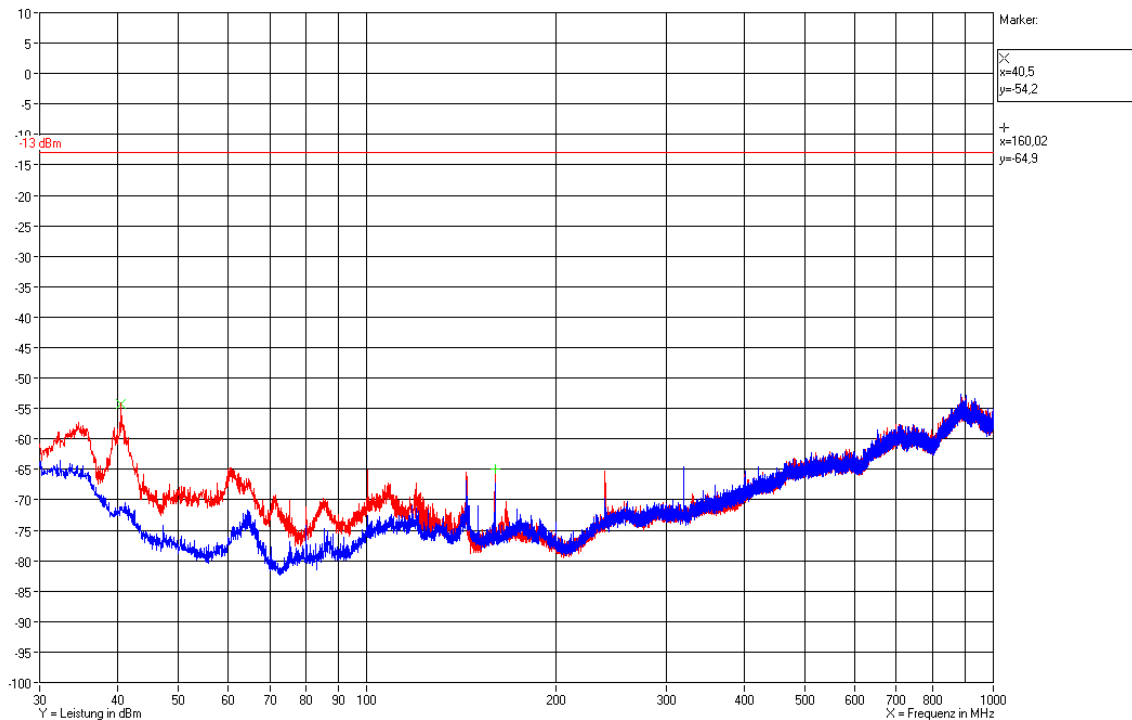

Measurement with Peak detector, BW 120KHz,
Step width 60 kHz, dwell time 10ms

Antenna height: 1.55m; all positions of the turn
table measured with max. hold function

Polarization: Horizontal / Vertical

No peak detected 20dB above noise

Test Report No.: 12-229

FCC ID: XS5- M717P

IC ID: 2237E- M717P



BUREAU
VERITAS

8.4.2 30 MHz to 1 GHz Downlink (middle of all paths)

F1: 728 MHz; F2: 751.5 MHz; F3: 2132.5 MHz (Operation with maximum composite power)

Horizontal / Vertikal

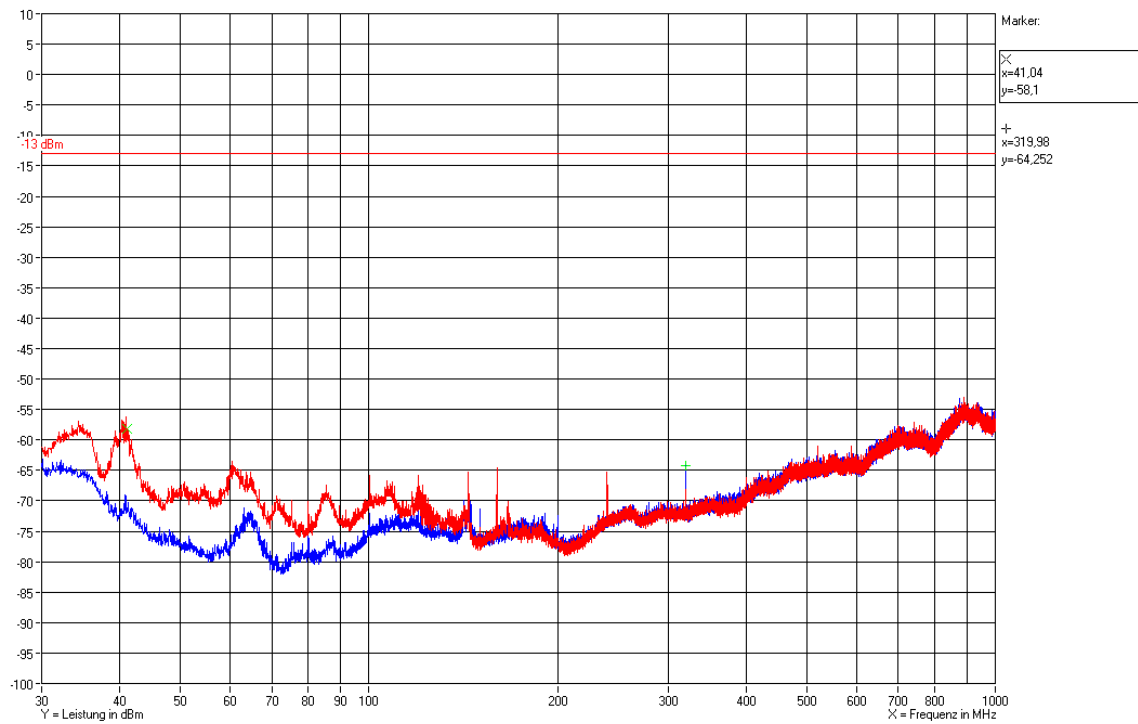

Measurement with Peak detector, BW 120KHz,
Step width 60 kHz, dwell time 10ms

Antenna height: 1.55m; all positions of the turn
table measured with max. hold function

Polarization: Horizontal / Vertikal

No peak detected 20dB above noise



8.4.3 1 GHz to 22 GHz Downlink (Bottom – Middle – Top)

B/M/T: 2110 MHz / 2132,5 MHz / 2155 MHz (Operation with maximum composite power)

Horizontal / Vertikal

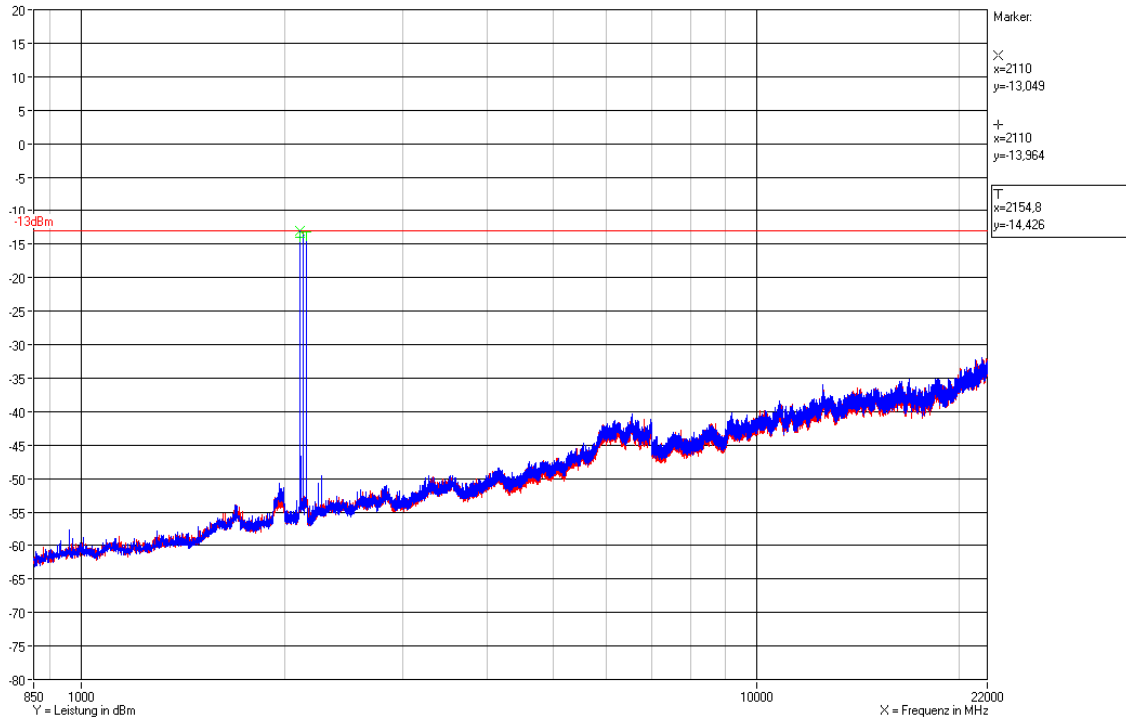

Measurement with Peak detector, BW 1000KHz,
Step width 500 kHz, dwell time 10ms

Antenna height: 1.55m; all positions of the turn
table measured with max. hold function

Polarization: Horizontal / Vertical

No peak, other than the fundamentals, detected
20dB above noise

Test Report No.: 12-229

FCC ID: XS5- M717P

IC ID: 2237E- M717P



BUREAU
VERITAS

8.4.4 1 GHz to 22 GHz Downlink (middle of all paths)

F1: 1962.5 MHz; F2: 2132.5 MHz (Operation with maximum composite power)

Horizontal / Vertikal

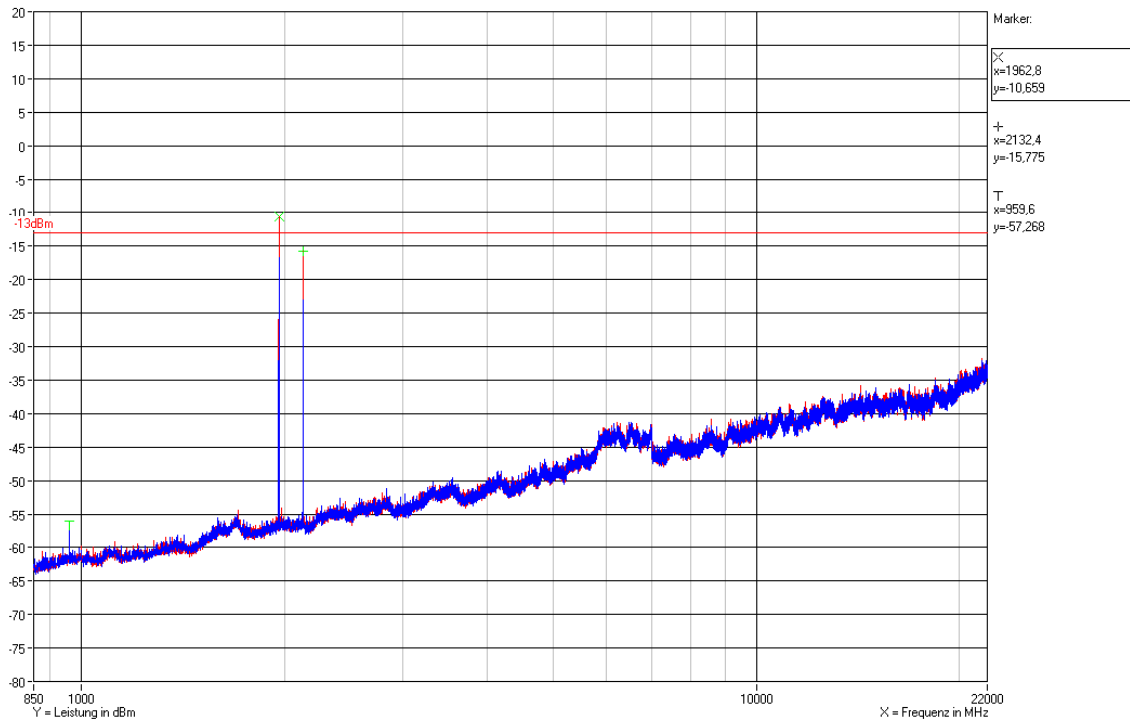

Measurement with Peak detector, BW 1000KHz,
Step width 500 kHz, dwell time 10ms

Antenna height: 1.55m; all positions of the turn
table measured with max. hold function

Polarization: Horizontal / Vertikal

No peak, other than the fundamentals, detected
20dB above noise

The radiated spurious emission requirements have been met in all frequency bands.

9 History

Revision	Modification	Date	Name
01.00	Initial Test report	23.05.2012	T. Zahlmann

Test Report No.: 12-229

FCC ID: XS5- M717P

IC ID: 2237E- M717P



BUREAU
VERITAS

***** End of test report *****