

# Optical Remote Unit ION™-M7P (M-cabinet)



Manual  
MF0143A8A

© Copyright 2011 CommScope, Inc.

All rights reserved.

Andrew Solutions is a trademark of CommScope, Inc.

All information contained in this manual has been revised thoroughly. Yet Andrew Solutions accepts no liability for any omissions or faults.

Andrew Solutions reserves the right to change all hard- and software characteristics without notice.

Names of products mentioned herein are used for identification purposes only and may be trademarks and / or registered trademarks of their respective companies.

No parts of this publication may be reproduced, stored in a retrieval system, transmitted in any form or by any means, electronic, mechanical photocopying, recording or otherwise, without prior written permission of the publisher.

Andrew Wireless Systems GmbH, 20-October-2011

---

## TABLE OF CONTENTS

<b>1. GENERAL</b>	<b>7</b>
1.1. USED ABBREVIATIONS	7
1.2. HEALTH AND SAFETY WARNINGS	8
1.3. ABOUT ANDREW SOLUTIONS	10
1.4. INTERNATIONAL CONTACT ADDRESSES FOR CUSTOMER SUPPORT	11
<b>2. FUNCTIONAL DESCRIPTION</b>	<b>13</b>
2.1. PURPOSE	13
2.2. THE ION-M7P (INTELLIGENT OPTICAL NETWORK; MMR)	13
2.3. COMPONENTS OF THE ION-M7P REMOTE UNIT	14
2.3.1. Fan-Protection Kit	14
2.3.2. Accessories	14
<b>3. COMMISSIONING</b>	<b>15</b>
3.1. MECHANICAL INSTALLATION	15
3.1.1. General	15
3.1.2. Wall-Mounting Procedure	16
3.1.3. Pole-Mounting Procedure	17
3.1.4. Mounting of Fan Protection	19
3.2. ELECTRICAL INSTALLATION	20
3.2.1. General	20
3.2.2. Connections	21
3.2.3. Grounding	22
3.3. CONNECTION OF THE ANTENNA CABLES	23
3.4. POWER CONNECTION	24
3.5. OPTICAL-FIBER-CABLE CONNECTION - RULES	25
3.5.1. Protective Plug	27
3.5.2. Protective-Tube Kit	29
3.6. COMMISSIONING	31
<b>4. ALARMS</b>	<b>34</b>
4.1. BITE AND ALARMS	34
4.2. HANDLING OF ALARMS	34
4.3. ALARM STATUS	34

---

<b>4.4.</b>	<b>STATUS LED ALARMS</b>	<b>35</b>
<b>4.5.</b>	<b>EXTERNAL ALARM INPUTS AND OUTPUTS</b>	<b>36</b>
<b>4.6.</b>	<b>TROUBLESHOOTING</b>	<b>37</b>
<b>5.</b>	<b>MAINTENANCE</b>	<b>38</b>
<b>5.1.</b>	<b>GENERAL</b>	<b>38</b>
<b>5.2.</b>	<b>REPLACING THE FAN UNIT</b>	<b>39</b>
<b>5.3.</b>	<b>CLEANING THE HEAT SINK</b>	<b>41</b>
<b>6.</b>	<b>APPENDIX</b>	<b>42</b>
<b>6.1.</b>	<b>ILLUSTRATIONS</b>	<b>42</b>
<b>6.2.</b>	<b>SPECIFICATIONS</b>	<b>43</b>
6.2.1.	Electrical Specifications	43
6.2.2.	Mechanical Specifications	43
6.2.3.	Environmental and Safety Specifications	43
<b>6.3.</b>	<b>SPARE PARTS</b>	<b>44</b>
<b>7.</b>	<b>INDEX</b>	<b>45</b>

**FIGURES AND TABLES**

figure 3-1 Wall mounting, (metric dimensions)..... 16

figure 3-2 Pole-mounting kit..... 17

figure 3-3 Pole mounting (metric dimensions) ..... 18

figure 3-4 Mounting procedure for fan protection, (metric dimensions)..... 19

figure 3-5 Connector flange of ION-M7P ..... 21

figure 3-6 RS485 connector..... 22

figure 3-7 Grounding bolt with loosened hex nut ..... 22

figure 3-8 Grounding bolt, schematic view..... 22

figure 3-9 AC mains plug ..... 24

figure 3-10 DC mains plug..... 24

figure 3-11 Protective-plug assembly ..... 27

figure 3-12 Tube-kit installation..... 30

figure 4-1 Flange connector, 5 poles ..... 36

figure 4-2 Flange connector, 7 poles ..... 36

figure 4-3 Alarm inputs and outputs, standard..... 37

figure 6-1 Installation drawing..... 42

table 1-1 List of international contact addresses..... 12

table 3-1 RS485 connector, PIN assignment..... 22

table 4-1 Status LED alarms..... 35

For your notes:

# 1. GENERAL

## 1.1. USED ABBREVIATIONS

3GPP	3 <sup>rd</sup> Generation Partnership Project
AC/DC	Alternating current / Direct Current
AIMOS	Andrew Integrated Management and Operating System
ALC	Automatic Level Control
BITE	Built-In Test Equipment
BTS	Base Transceiver Station
CE	"Conformité Européenne" ("European Conformity")
CD	Compact Disk
CPD	Channel Power Detection
DL	Downlink
DoC	Declaration of Conformity
EDGE	Enhanced Data Rates for GSM Evolution
EN	European Norm
EP	Extension Port
ESD	Electrostatic Discharge
ETS	European Telecommunication Standard
EU	Extension Unit
GSM	Global System for Mobile Communication
GND	Ground
GUI	Graphical User Interface
ICP3	Intercept Point 3 <sup>rd</sup> order
ID No	Identification Number
ION	Intelligent Optical Network
IP	Ingress Protection
ISO	International Organization for Standardization
LED	Light Emitting Diode
LMT	Local Maintenance Terminal
LTE	Long Term Evolution
MIMO	Multiple Input Multiple Output
MS	Mobile Station
MU	Main Unit
NF	Noise Figure
OTRx	Optical Transceiver = SRMU (Subrack Master Unit)
PG	Packing Gland
PIM	Passive Intermodulation
R&TTE	Radio & Telecommunications Terminal Equipment
Rev	Revision
RF	Radio Frequency
RU	Remote Unit
RX	Receiver
SNMP	Simple Network Management Protocol
TS	Technical Specification
TX	Transmitter
UL	Uplink
UMTS	Universal Mobile Telecommunication System
UPS	Uninterruptible Power Supply
VSWR	Voltage Standing Wave Ratio
WCDMA	Wideband Code Division Multiple Access
WDM	Wavelength Division Multiplex

## 1.2. HEALTH AND SAFETY WARNINGS



1. Only suitably qualified personnel is allowed to work on this unit and only after becoming familiar with all safety notices, installation, operation and maintenance procedures contained in this manual.
2. Read and obey all the warning labels attached to the unit. Make sure that the warning labels are kept in a legible condition and replace any missing or damaged labels.
3. Obey all general and regional installation and safety regulations relating to work on high voltage installations, as well as regulations covering correct use of tools and personal protective equipment.
4. Keep operating instructions within easy reach and make them available to all users.
5. It is the responsibility of the network provider to implement prevention measures to avoid health hazards which may be associated to radiation from the antenna(s) connected to the unit.
6. **Note for a Class A digital device or peripheral:**

**This equipment has been tested and found to comply with the limits for a Class A digital device, pursuant to part 15 of the FCC Rules. These limits are designed to provide reasonable protection against harmful interference when the equipment is operated in a commercial environment. This equipment generates, uses, and can radiate radio frequency energy and, if not installed and used in accordance with the instruction manual, may cause harmful interference to radio communications. Operation of this equipment in a residential area is likely to cause harmful interference in which case the user will be required to correct the interference at his own expense.**
7. Make sure, access is restricted to qualified personnel.
8. Only licence holders for the respective frequency range are allowed to operate this unit.
9. Corresponding local particularities and regulations must be observed. For national deviations please refer to the respective documents included in the manual CD delivered.
10. Use this equipment only for the purpose specified by the manufacturer. Do not carry out any modifications or fit any spare parts which are not sold or recommended by the manufacturer. This could cause fires, electric shock or other injuries.
11. Due to power dissipation, the repeater may reach a very high temperature. Do not operate this equipment on or close to flammable materials.



12. Before opening the unit, disconnect mains.



13. ESD precautions must be observed! Before commencing maintenance work, use the available grounding system to connect ESD protection measures.

14. This unit complies with European standard EN60950.

15. Make sure the repeater settings are according to the intended use (see also product information of manufacturer) and regulatory requirements are met.

16. Although the repeater is internally protected against overvoltage, it is strongly recommended to earth the antenna cables close to the repeater's antenna connectors for protection against atmospheric discharge.



17. Laser radiation! Do not stare into the beam; do not view it directly or with optical instruments.

### 1.3. ABOUT ANDREW SOLUTIONS

*Andrew Wireless Systems GmbH* based in Buchdorf/ Germany, is a leading manufacturer of coverage equipment for mobile radio networks, specializing in high performance, RF and optical repeaters. Our optical distributed networks and RF repeater systems provide coverage for every application: outdoor use, indoor installations, tunnels, subways and many more.

*Andrew Wireless Systems GmbH* has unparalleled experience in providing RF coverage and capacity solution for wireless networks in both indoor and outdoor environment and belongs to *Andrew Solutions, a CommScope Company*.

*Andrew Solutions* is the foremost supplier of one-stop, end-to-end radio frequency (RF) solutions. Our products are complete solutions for wireless infrastructure from top-of-the-tower base station antennas to cable systems and cabinets, RF site solutions, signal distribution, and network optimization.

*Andrew Solutions* has global engineering and manufacturing facilities. In addition, it maintains field engineering offices throughout the world.

We operate a quality management system in compliance with the requirements of ISO 9001. All equipment is manufactured using highly reliable material. In order to ensure constant first-rate quality of the products, comprehensive quality monitoring is conducted at all fabrication stages. Finished products leave the factory only after a thorough final acceptance test, accompanied by a test certificate guaranteeing optimal operation.

☞ **Note:** **Exceptions of and national deviations from this intended use may be possible. To observe corresponding local particularities and regulations, please refer to the respective documents (also in national language) which are included in the manual CD delivered.**

To make the most of this product, we recommend you carefully read the instructions in this manual and commission the system only according to these instructions.

For technical assistance and support, please also contact the local office or *Andrew Solutions* directly at one of the addresses listed in the following chapter.

## 1.4. INTERNATIONAL CONTACT ADDRESSES FOR CUSTOMER SUPPORT

### Americas:

<b>Canada</b>	
<b>Andrew Solutions Canada</b>	
Mail	620 North Greenfield Parkway Garner, NC 27529 U.S.A.
Phone	+1-905-878-3457 (Office) +1-416-721-5058 (Mobile)
Fax	+1-905-878-3297
E-mail	Peter.Masih@commscope.com, Wlsupport.us@commscope.com

<b>United States</b>	
<b>Andrew Solutions, Andrew LLC, A CommScope Company</b>	
Mail	620 North Greenfield Parkway Garner, NC 27529 U.S.A.
Phone	+1-888-297-6433
Fax	+1-919-329-8950
E-mail	Wlsupport.us@commscope.com

<b>Brazil &amp; South America</b>	
<b>CommScope Cabos do Brasil Ltda.</b>	
Mail	Av. Com. Camilo Julio 1256 Zonal Industrial CP 597 Sorocaba SP 18086-000 Brazil
Phone	+ 55-15-9104-7722
Fax	+ 55-15-2102-4001
E-mail	Wlsupport@commscope.com

<b>Mexico, Central America &amp; Caribbean region</b>	
<b>Andrew Corporation Mexico, SA DE CV</b>	
Mail	Av. Insurgentes Sur 688, Piso 6 Col. Del Valle, CP: 03100 Mexico City Mexico
Phone	+52-55-1346-1900 (Office) +52-1-55-5419-5260 (Mobile)
Fax	+52-55-1346-1901
E-mail	Wlsupport@commscope.com

### APAC Countries:

<b>China, India and Rest of Asia</b>	
<b>Andrew International Corporation</b>	
Mail	Room 915, 9/F Chevalier Commercial Centre 8 Wang Hoi Rd Kowloon Bay Hong Kong
Phone	+852-3106-6100
Fax	+852-2751-7800
E-mail	Wlsupport.China@commscope.com

<b>Australia &amp; New Zealand</b>	
<b>Andrew Corporation (Australia) Pty Ltd.</b>	
Mail	Unit 1 153 Barry Road Campbellfield VIC 3061 Australia
Phone	+613-9300-7969
Fax	+613-9357-9110
E-mail	Wlsupport.Australia@commscope.com

## Europe:

<b>United Kingdom</b>		<b>France</b>	
Mail	<b>Andrew Solutions UK Ltd</b> Unit 15, Ilex Building Mulberry Business Park Fishponds Road Wokingham Berkshire RG41 2GY England	Mail	<b>CommScope France</b> Immeuble Le Lavoisier 4, Place des Vosges 92052 Courbevoie France
Phone	+44-1189-366-792	Phone	+33-1 82 97 04 00
Fax	+44-1189-366-773	Fax	+33-1 47 89 45 25
E-mail	Wlsupport.uk@commscope.com	E-mail	Wlsupport@commscope.com
<b>Germany</b>		<b>Czech Republic</b>	
Mail	<b>Andrew Wireless Systems GmbH</b> Industriering 10 86675 Buchdorf Germany	Mail	<b>Andrew Solutions Czech Republic C-Com, spol. s r.o</b> U Moruší 888 53006 Pardubice Czech Republic
Phone	+49-9099-69-0	Phone	+420-464-6280-80
Fax	+49-9099-69-930	Fax	+420-464-6280-94
E-mail	Wlsupport@commscope.com	E-mail	Wlsupport@commscope.com
<b>Austria</b>		<b>Switzerland</b>	
Mail	<b>Andrew Wireless Systems (Austria) GmbH</b> Weglgasse 10 2320 Wien-Schwechat Austria	Mail	<b>Andrew Wireless Systems AG</b> Tiergartenweg 1 CH-4710 Balsthal Switzerland
Phone	+43-1706-39-99-10	Phone	+41-62-386-1260
Fax	+43-1706-39-99-9	Fax	+41-62-386-1261
E-mail	Wlsupport.austria@commscope.com	E-mail	Wlsupport.ch@commscope.com
<b>Italy</b>		<b>Spain and Portugal</b>	
Mail	<b>Commscope Italy S.r.l., Faenza, Italy</b> Via Mengolina, 20 48018 Faenza (RA) Italy	Mail	<b>Andrew Solutions España S.A. A Commscope Company</b> Avda. de Europa, 4 - 2ª pta. Parque Empresarial La Moraleja 28108 Alcobendas (Madrid) Spain
Phone	+39-0546-697111	Phone	+34-91-745-20 40
Fax	+39-0546-682768	Fax	+34-91-661-87 02
E-mail	Wlsupport.italia@commscope.com	E-mail	Wlsupport.iberia@commscope.com

table 1-1 List of international contact addresses

## **2. FUNCTIONAL DESCRIPTION**

### **2.1. PURPOSE**

Cellular telephone systems transmit signals in two directions between base transceiver station (BTS) and mobile stations (MS) within the signal coverage area.

If weak signal transmissions occur within the coverage area because of indoor applications, topological conditions or distance from the transmitter, extension of the transmission range can be achieved by means of an optical distribution system.

Such a system contains an optical Master Unit and several Remote Units. The number of the Remote Units depends on the hardware and software configuration. The Remote Units are connected to the Master Unit with optical links. The optical loss must be less than 10 dB inclusive optical couplers or splitters.

The Master Unit is the connection to the base transceiver stations. The configuration of a Master Unit depends on the number of the Remote Units and the frequency range.

WDM (Wave Division Multiplex) filters are integrated in the optical modules. For the UL, a wavelength within 1540 nm – 1562 nm is used. For the DL, a wavelength of 1310 ±20 nm is used. The maximum output power for the UL and DL is 5.7 mW.

### **2.2. THE ION-M7P (INTELLIGENT OPTICAL NETWORK; MMR)**

The fibre-optic distribution system is designed for LTE 700 MHz services. Each fibre is able to operate services of up to four providers. One Master Unit can operate up to 124 Remote Units.

An auto-levelling function for compensating different fibre losses and a comprehensive supervision concept are implemented. Auto-levelling in the DL works with optical power measurement, in the UL a 10.7 MHz signal is used for measuring the optical loss.

The Remote Unit ION-M7P is connected to a central Master Unit via optical fibre lines. Specific customer designs for lamp pole or wall mounting are available. Thus, the system provides many advantages in view of easy site acquisition.

## **2.3. COMPONENTS OF THE ION-M7P REMOTE UNIT**

### **2.3.1. Fan-Protection Kit**

In order to protect the fan unit (e.g. against rain), a protective cover to be mounted over the air inlet is delivered with the unit. For more details see chapter 3.1.4 *Mounting of Fan Protection*.

**Mounting of the fan-protection kit is only mandatory for outdoor applications,** however, not mandatory for indoor applications.

### **2.3.2. Accessories**

For the accessories available for the Remote Unit, e.g. overcoat housing, connecting box or iso-trafo kit, a separate manual is available.

## 3. COMMISSIONING

### 3.1. MECHANICAL INSTALLATION

#### 3.1.1. General

Read the health and safety warnings in chapter *1.2 Health and Safety Warnings*.

1. Do not install the unit in a way or at a place where the specifications outlined in the Environmental and Safety Specifications leaflet of the supplier are not met.
2. It is recommended only to use the mounting hardware delivered by the supplier. If different mounting hardware is used, the specifications for stationary use of the Remote Unit must not be exceeded.

 **Note:** Exceeding the specified load limits may cause the loss of warranty!



3. The unit is considerably heavy. Make sure that a suitable mounting surface is used. Ensure there is adequate manpower to handle the weight of the system.
4. Due to power dissipation, the Remote Unit may reach a very high temperature. Ensure sufficient airflow for ventilation as specified in the individual mounting procedures.
5. When connecting and mounting the cables (RF, optical, mains, ...) ensure no water can penetrate into the unit through these cables.
6. Also observe all additional rules or restrictions regarding mounting that depend on the type of Remote Unit. For details refer to chapter *7.2.2 Mechanical Specification*. Install the unit vertically with the fan unit at the top. A maximum tilt angle of 25° from a vertical position must be kept, as in the following illustrations:

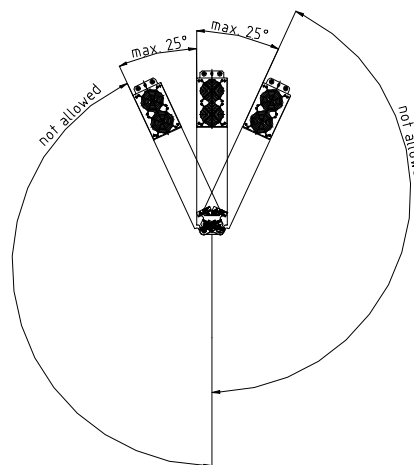
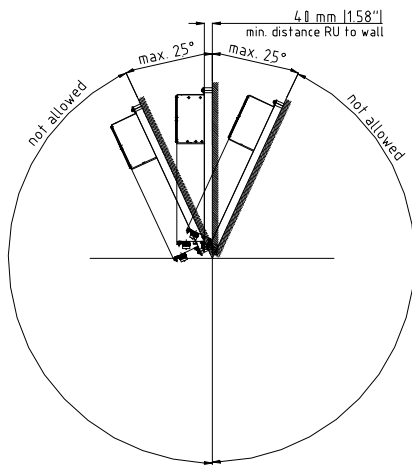

7. A spacing of 40 mm (1.58 inch) around the unit is required.
8. To ensure sufficient airflow when mounting the unit in enclosed spaces, two lid openings (one for the air inlet and the other for the air outlet) have to be provided. Do not block these air inlets and outlets when mounting the Remote Unit. The size of each opening must equal at least 12 x 12 cm (144 cm<sup>2</sup>). Make sure, too, there is no thermal short circuit between the air inlet and air outlet.

### 3.1.2. Wall-Mounting Procedure

- Check the suitability of the wall-mounting kit and the wall.
- Mark the position of the drilling holes (for measurements refer to *figure 3-1 Wall mounting*). Drill four holes at the marked positions and insert dowels \*.
- Use a cap nut or lock nut to screw the four dowel screws into the dowels and put the distance tubes over the screws.
- Hang the mounting brackets of the Remote Unit into the screws, and fasten them immediately using the washers and nuts.
- Ensure that there is free access to the electrical connections as well as to the cabinet. The approved bending radius of the connected cables must not be exceeded.

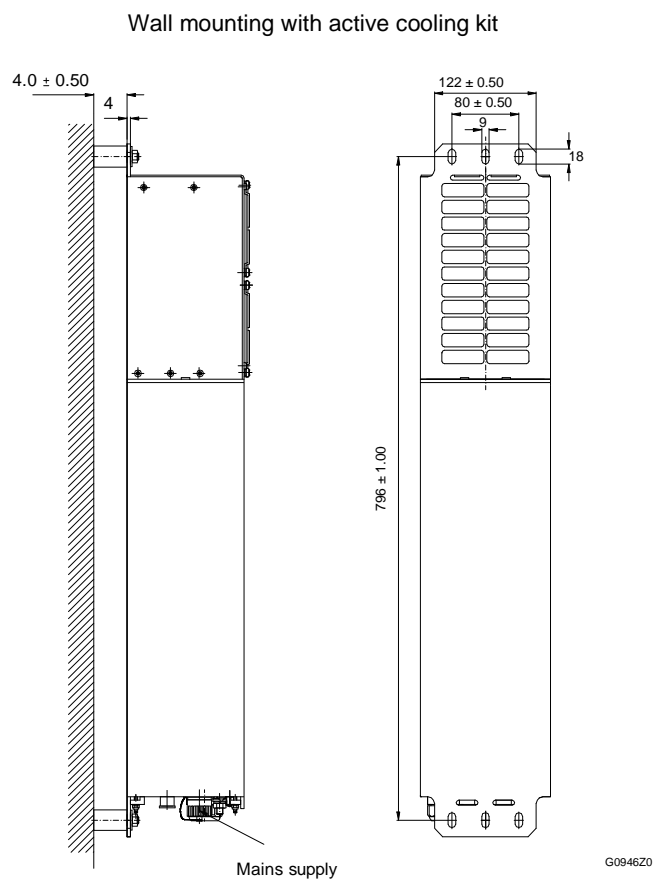

*figure 3-1 Wall mounting, (metric dimensions)*

\* The dowels are not part of the delivery since the suitable type depends on the on-site conditions (material of wall). Therefore, use dowels that are appropriate for the mounting surface.



### 3.1.3. Pole-Mounting Procedure

Standard mounting hardware cannot be used to mount the Remote Unit to a pole, a column or other similar structures. Additional hardware must be used for this type of installation. Such a pole-mounting kit could include two threaded rods M8, two U-beams and mounting material like bolts and nuts.

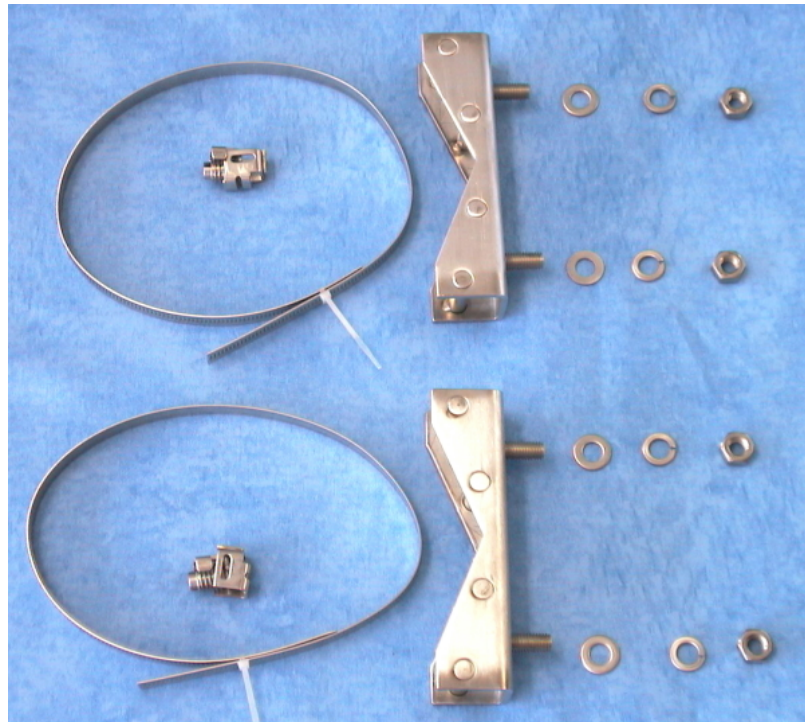

B0113AUA

*figure 3-2 Pole-mounting kit*

- Use the screw bands to fasten the two U-beams to the pole as illustrated in *figure 3-3 Pole mounting*.

**Note:** When fastening the U-beams make sure that they are installed congruently and not at an angle to each other. To determine the distance between the beams refer to *3.1.2 Wall-Mounting Procedure* for measurements.

- Hang the mounting brackets of the Remote Unit into the threaded bolts of the U-beam, and fasten them immediately using the washers and nuts.

Ensure that there is free access to the electrical connections as well as to the cabinet. The approved bending radius of the connected cables must not be exceeded.

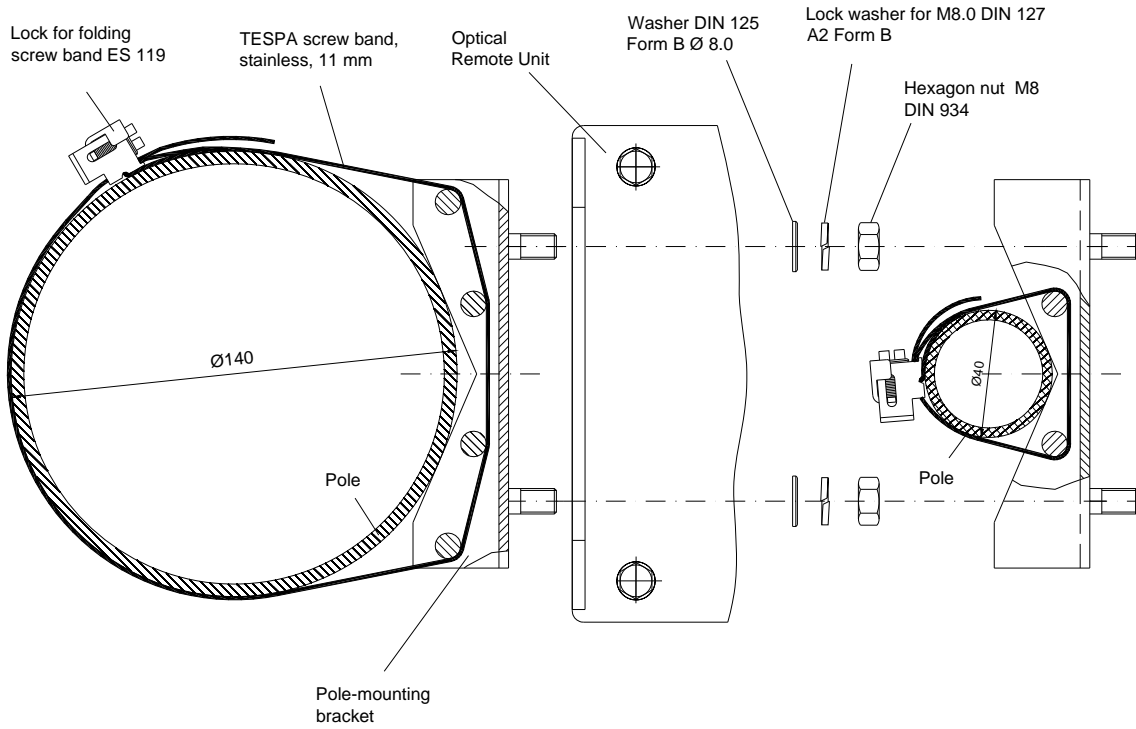

G0764M6

figure 3-3 Pole mounting (metric dimensions)

### 3.1.4. Mounting of Fan Protection

Since the fan protection is required for the outdoor usage of a stand-alone Remote Unit, the mounting of this optional equipment is also described in this manual.

- To install the protective cover of the fan protection kit, first unscrew the four screws with the respective lock washers from the cover of the air inlet of the Remote Unit, and instead, screw in the four spacing bolts M4.0x30 with the four lock washers M4.0 DIN125 that are part of the fan protection kit.
- Place the protective cover into the right position by fitting its four bore holes over the spacing bolts and fasten it using the original lock washers and screws of the Remote Unit. (These lock washers and screws are also part of the fan protection kit and can be used as spare parts in case of loss.)

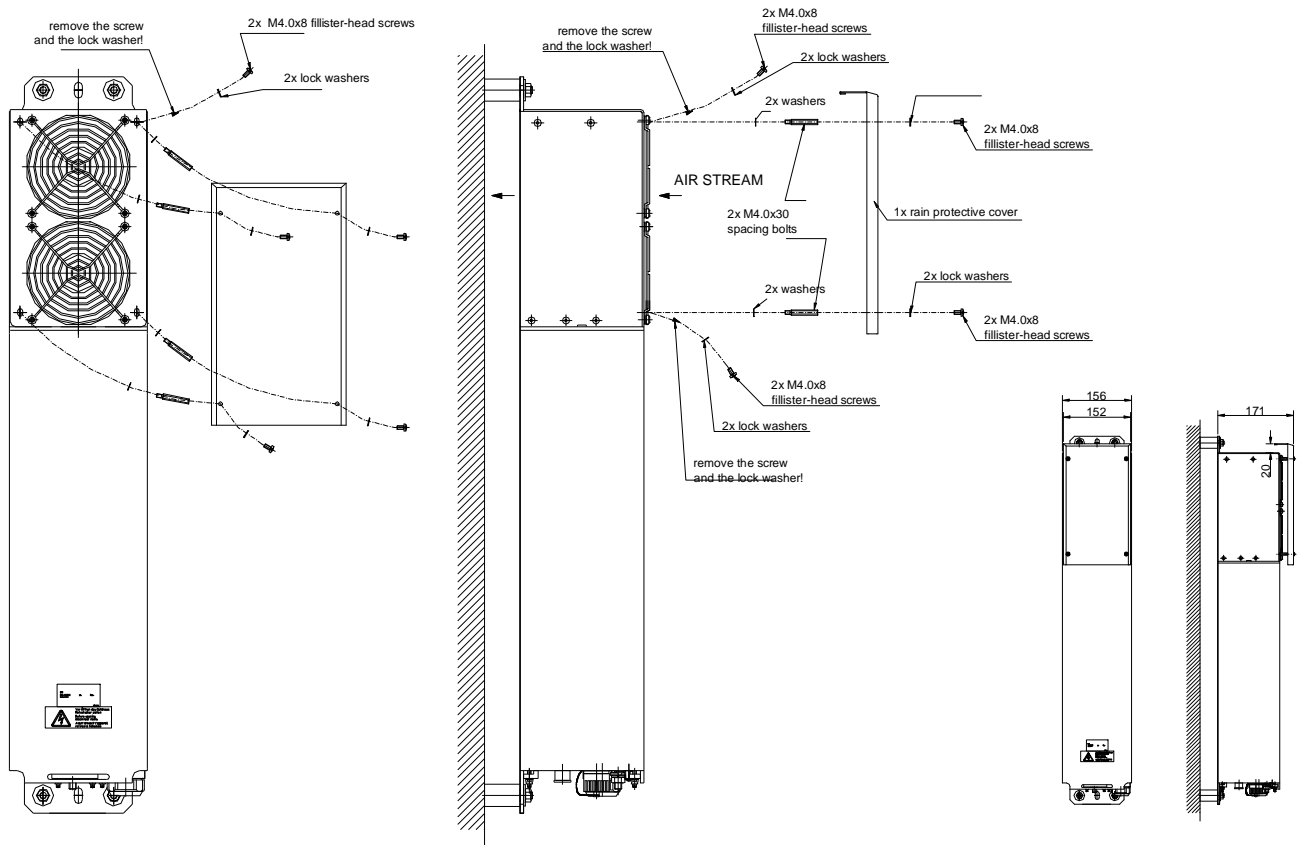

G0496MF

figure 3-4 Mounting procedure for fan protection, (metric dimensions)

## 3.2. ELECTRICAL INSTALLATION

### 3.2.1. General

Read the health and safety warnings in chapter 1.2.



1. This unit contains dangerous voltages. Loss of life, severe personal injury or property damage can be the result if the instructions contained in this manual are not followed.
2. Ground the unit before connecting power supply. A grounding bolt is provided on the cabinet to connect the ground-bonding cable.
3. Although the Remote Unit is internally protected against over-voltage, it is strongly recommended to earth the antenna cables close to the antenna connectors of the Remote Unit for protection against atmospheric discharge. In areas with strong lightning it is highly recommended to insert additional lightning protection.
4. If the mains connector of the Remote Unit is not easily accessible, a disconnect device in the mains circuit must be provided within easy reach.
5. Before connecting or disconnecting the mains connector at the Remote Unit, ensure that mains supply is disconnected.
6. Make sure that an appropriate circuit breaker and an over-current limiting device are connected between mains and Remote Unit.
7. A connection of mains supply to a power socket requires the power socket to be nearby the Remote Unit.
8. Incorrectly wired connections can destroy electrical and electronic components.
9. To avoid corrosion at the connectors caused by electrochemical processes, the material of the cable connectors must not cause a higher potential difference than 0.6 V (see electrochemical contact series).
10. Use an appropriate torque wrench for the coupling torque of N-type connectors (2 N-m / 20 in lb), with 13/16 in opening to tighten the N-type antenna connectors. For example, use torque wrench of item no. 244379 available from the *Andrew e-catalog*. Do NOT use your hands or any other tool (e.g. a pair of pliers)! This might cause damage to the connector and lead to a malfunction of the Remote Unit.
11. Use a voltage limiting device for unstabilized electric networks that frequently generate spikes.

12. The unit complies with the surge requirement according to EN 61000-4-5 (fine protection); however, it is recommended to install an additional medium (via local supply connection) and/or coarse protection (external surge protection), depending on the individual application, in order to avoid damage caused by overcurrent.
13. Observe the labels on the front panels before connecting or disconnecting any cables.

### 3.2.2. Connections

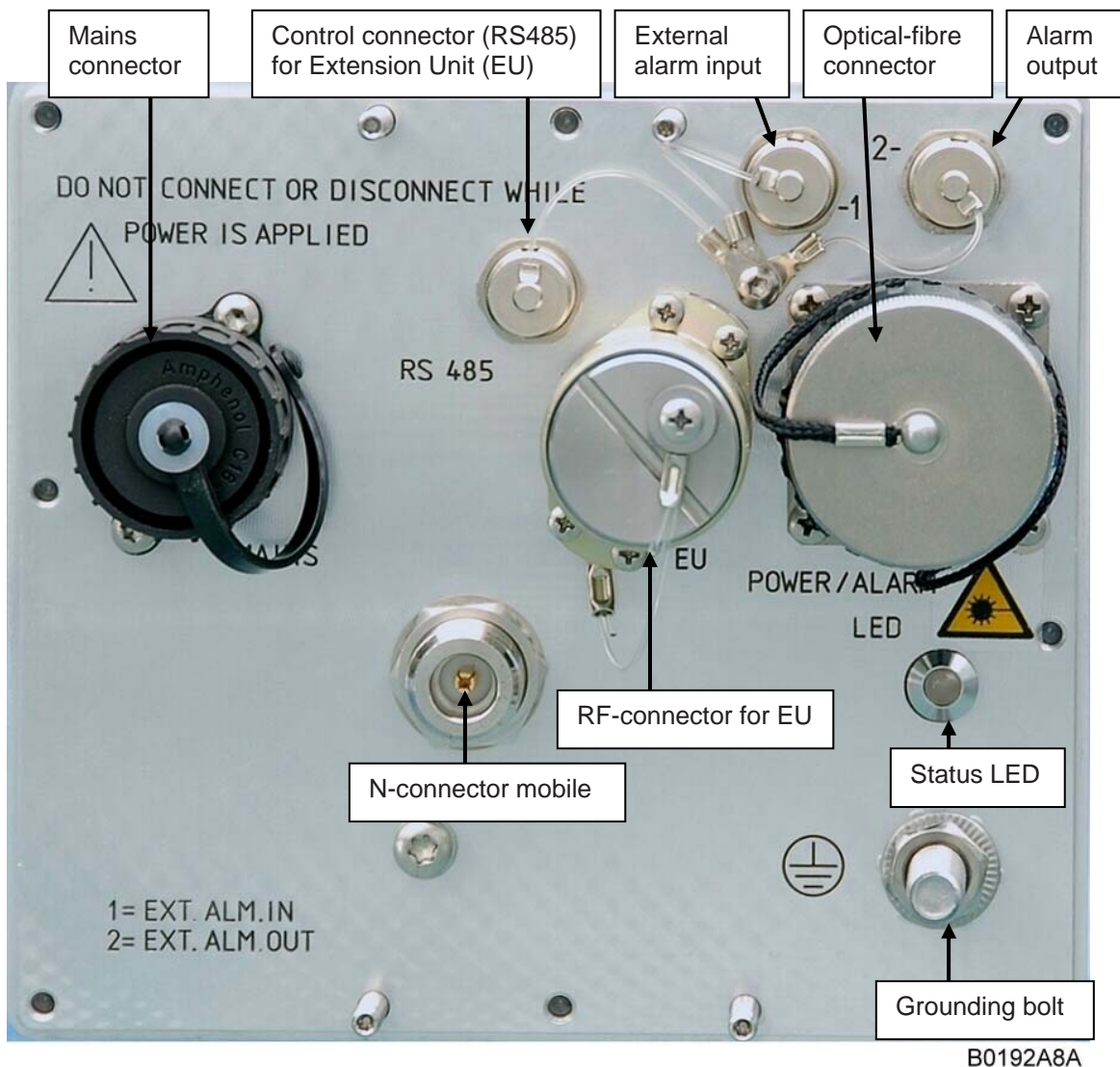
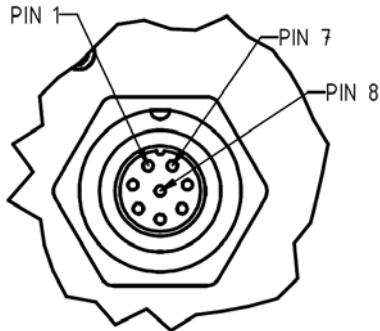

figure 3-5 Connector flange of ION-M7P

For detailed description of the external alarms please refer to chapter 4.5 *External Alarm Inputs and Outputs*.

### 3.2.2.1. Control Connector (RS485 / RS232) for Extension Unit

This 8-pin male connector (type: Binder Series 712) primarily supports control of the Extension Unit via RS485 bus.



PIN	Assignment
1	not connected
2	RS232 Rx
3	RS232 Tx
4	not connected
5	GND (RS232)
6	RS485 R+/D+
7	RS485 GND
8	RS485 R-/D-

figure 3-6 RS485 connector

table 3-1 RS485 connector, PIN assignment

### 3.2.3. Grounding

Grounding must be carried out. Connect an earth-bonding cable to the grounding connection provided at the outside of the Remote Unit (see chapter 3.2.2 Connections). Do not use the grounding connection to connect external devices.



figure 3-7 Grounding bolt with loosened hex nut

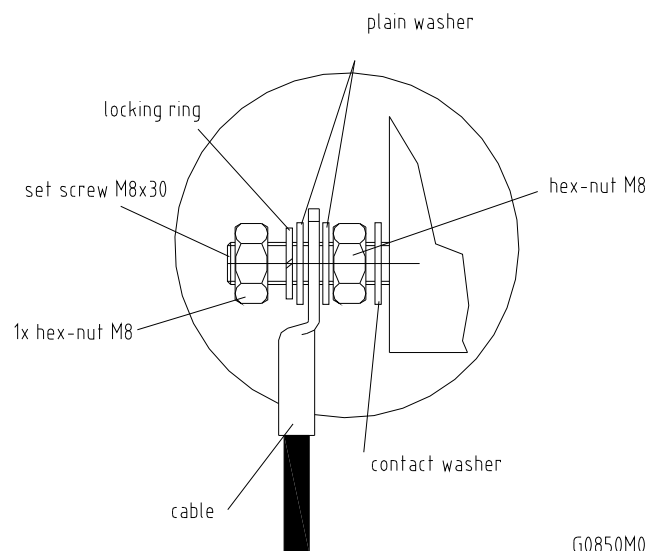

figure 3-8 Grounding bolt, schematic view

After loosening the hex nut, connect the earth-bonding cable between the two washers as illustrated in the figures above. Then, fasten all parts again with the hex nut.



### 3.3. CONNECTION OF THE ANTENNA CABLES

The Remote Unit has 7/16-type antenna connectors. For its location please refer to chapter 3.2.2 *Connections*. For mounting the cable connectors, it is recommended to refer to the corresponding documentation of the connector manufacturer. The bending radius of the antenna cables must remain within the given specifications.

For the selection of cable and antenna it should be considered that, on the one hand, a cable with higher loss is less expensive but, on the other hand, it impairs performance.



**Use an appropriate torque wrench for the coupling torque of N-type connectors (2 N-m / 20 in lb), with 13/16 in opening to tighten the N-type antenna connectors. For example, use torque wrench of item no. 244379 available from the *Andrew e-catalog*. Do NOT use your hands or any other tool (e.g. a pair of pliers)! This might cause damage to the connector and lead to a malfunction of the Remote Unit.**



**To minimize passive inter-modulation (PIM) distortion, attention has to be paid to the physical condition of the connector junctions. Do not use connectors that show signs of corrosion on the metal surface. Prevent the ingress of water into the connector. Attach and torque the connectors properly.**

### 3.4. POWER CONNECTION

Before connecting electrical power to the units, the system must be grounded as described in the previous chapter.

Mains power must be connected at the mains connector of the unit (see chapter 3.2.2 *Connections*).

The power supply plug is part of the delivery. The correct wiring of the power supply plug is as follows:

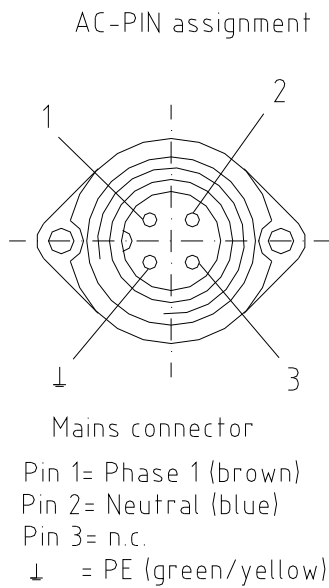

G1038Z0

figure 3-9 AC mains plug

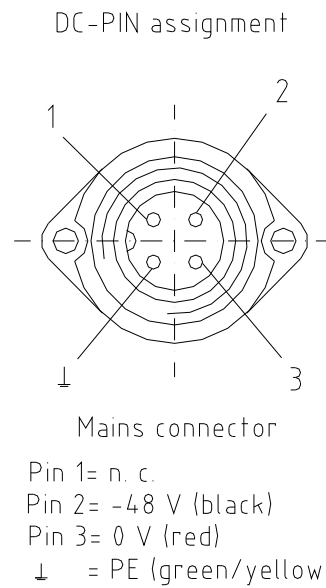

G1038Z0

figure 3-10 DC mains plug



**For the AC power supply connection, a minimum cross section of 1.5 mm<sup>2</sup> is required, and for the DC power supply connection a minimum cross section of 2.5 mm<sup>2</sup> is required. Each wire must observe the applicable national regulations regarding loop impedance, voltage drop, and methods of installation. Make sure to connect the correct voltage to the unit.**

**Note:** Do not connect or disconnect the power cord at the mains connector while power is on. Turn off mains power \* before connecting the power cord at the Remote Unit, then, engage mains again.

\* Mains power must be interruptible with an external mains breaker. For the mains breaker, observe the following recommendation:

120 Volt / 20 Amp max. or 240 Volt / 16 Amp, single-phase, 50 / 60 Hz AC service is needed, i.e. the external AC breaker should be 20 Amps max. for 120-Volt service or 16 Amps for 240-Volt service.

For the DC power supply, observe the local regulations of the DC service provider.



### 3.5. OPTICAL-FIBER-CABLE CONNECTION - RULES

#### Main optical system parameters:

Fiber:

- Single mode fiber, type is E9/125  $\mu\text{m}$
- Attenuation:  $<0.36 \text{ dB / km @ } 1310 \text{ nm}$  /  $<0.26 \text{ dB / km @ } 1550 \text{ nm}$
- Dispersion:  $<3.5 \text{ ps / nm km @ } 1310 \text{ nm}$  /  $<18.0 \text{ ps / nm km @ } 1550 \text{ nm}$
- Fibre-cable connectors E2000APC8°

ION-M system:

- The specified bending radius ( $< 4 \text{ cm}$ ) of the optical fibers must not be exceeded.
- The pigtails for the connection between Master Unit and Remote Unit must have a sufficient length. A protection for the feeding into units must be given.
- The system attenuation of the optical fibers, including the connectors, must not exceed 10 dB.

System attenuation and attenuation of optical components must be determined. This can be achieved by measuring attenuation and reflection with an appropriate measuring instrument. For pigtails, a total value of  $< 0.4 \text{ dB}$  (measured to a reference plug) can be assumed due to the dead zone of the reflectometer. These measurements must be made with a sufficient length of optical fiber, at the input and output of the device which has to be measured.

#### Fiber-System Installation:

Fiber-cable connectors have to be of the same type (E2000APC8°) as the connectors used for the unit. The fiber-optic cables are connected to the optical transceiver.



**Angled connectors are not compatible with straight optical connectors; non-compatibility of connectors will result in permanent damage to both connectors.**

Before connecting the fiber cables, follow the procedure below to ensure optimized performance. It is important for these procedures to be carried out with care:

- Remove fiber-optic protective caps.
- Do not bend the fiber-optic cable in a tight radius ( $< 4 \text{ cm}$ ) as this may cause cable damage and interrupt transmission.
- Using high-grade alcohol and lint-free cotton cleaning swabs, clean the end of the fiber-optic cable that will be inserted in the optical connectors on the donor interface box. Use a fiber end-face inspection tool to scan both, the class fiber and its surrounding area.

- Check for dirt on the cladding, chips/pits, dirt on the ferrule, and scratches.
- Connect the fiber-optic cables by inserting the cable end into the laser receptacle and aligning the key (on the cable end) with the keyed slot.
- Do not use any index-matching gels or fluids of any kind in these connectors. Gels are intended for laboratory use and attract dirt in the field.

 **Note:** Care should be taken when connecting and disconnecting fiber-optic cables - use the connector housing to plug or unplug a fiber. Scratches and dust significantly affect system performance and may permanently damage the connector. Always use protective caps on fiber-optic connectors not in use.

### **Cleaning Procedure for Fiber-Optical Components:**

Any contamination in the fiber connection results in additional optical transmission loss which could cause whole system failure. It is thus recommended that every fiber connector be inspected and cleaned prior to mating.

The goal is to eliminate any dust or contamination and to provide a clean environment for the fiber-optic connection.

When you clean fiber components, always complete the following steps carefully:

1. Turn off the ION system (laser sources) before you inspect fiber connectors.



**Never look into a fiber while the system lasers are on!**

2. Check the connectors or adapters with a fiberscope before cleaning.
3. If the connector is dirty, clean it with a lint-free wipe (dry cleaning).
4. Inspect the connector.
5. If the connector is still dirty, repeat the dry cleaning technique.
6. Inspect the connector.
7. If the connector is still dirty, clean it with 99% isopropyl alcohol (wet cleaning) followed immediately with a dry clean in order to ensure no residue is left on the endface.
8. Repeat steps 5 through 7 until endface is clean.

Note: For a more detailed description please refer to:

[http://www.cisco.com/en/US/tech/tk482/tk876/technologies\\_white\\_paper09186a0080254eba.shtml](http://www.cisco.com/en/US/tech/tk482/tk876/technologies_white_paper09186a0080254eba.shtml)

### 3.5.1. Protective Plug

**Connection:**

A protective plug is provided for the connection of the fibre-optic cables.

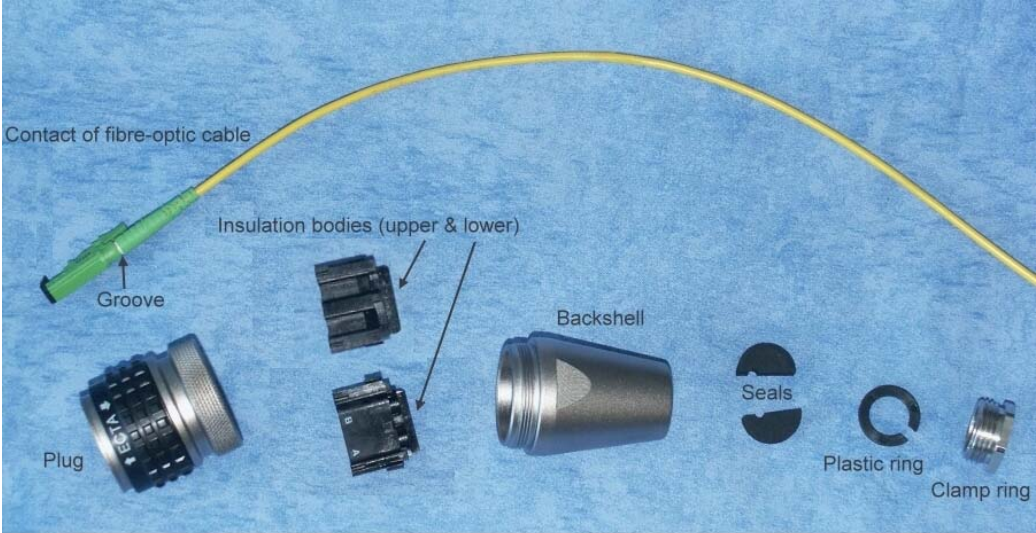

*figure 3-11 Protective-plug assembly*

**Note:** Only high-quality connectors must be used for this type of plug. Qualified brands are Diamond or Huber & Suhner.

For plug assembly, observe the following instruction:

1. Pass one or two contacts through the backshell and the clamp ring.



B0122A1A

2. Place the contact(s) on the lower insulation body by pushing the groove of the contact into the cavity. If there is only one contact, cavity A **must** be used. \*
3. Then, mount the upper insulation body on the lower insulation body. \*\*

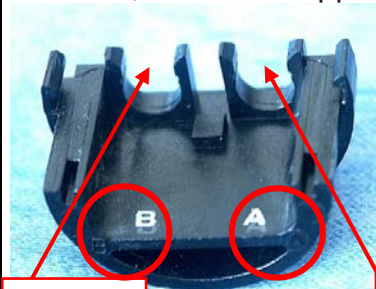

Cavity B

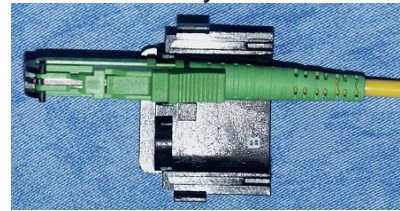

B0122ALA

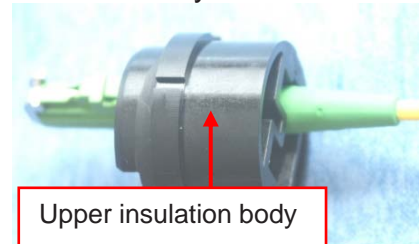

Upper insulation body

B0122A4A

4. Bring the insulator into the plug. The narrow groove of the insulator must be fitted into the stamp of the plug.

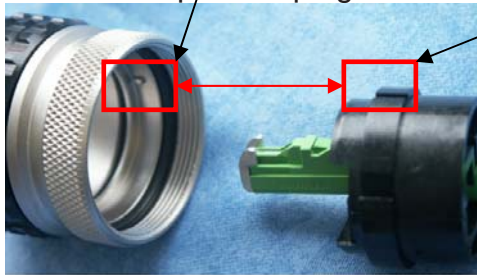

B0122AEA

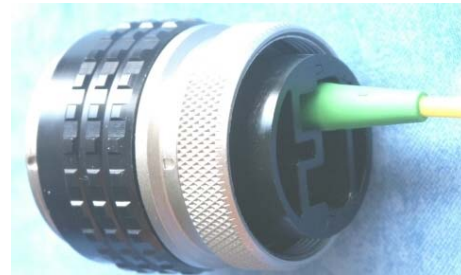

B0122A6A

- \* To release the contact for disassembling, push the inner snap to the side and pull the contact out.
- \*\* To release upper and lower insulation bodies for disassembling, use a small screwdriver and carefully open the snap-connections at the left and the right side of the insulator without damaging them.

5. Fasten the insulator by screwing the backshell tight onto it. Use a spanner with opening 32 to screw the backshell tight (no gap).

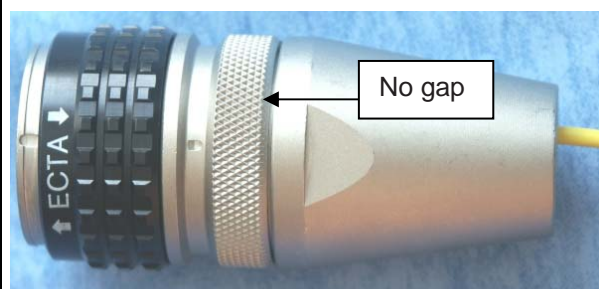

B0122A7A

6. Place the appropriate seal parts (with one groove for one contact or two grooves for two contacts) over the cable(s) and push them into the backshell.

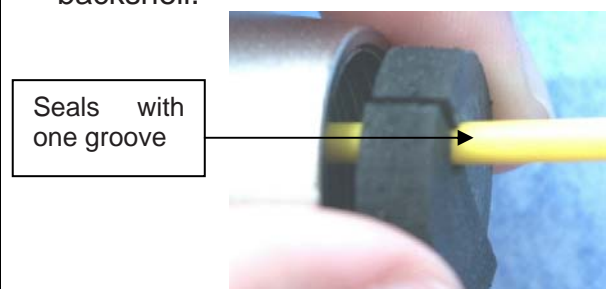

B0122A8A



7. Bring the plastic ring over the cable(s), push it into the backshell and compress the seals and plastic ring by screwing the clamp ring tight (no gap) using a spanner with opening 20. \*\*\*



B0122A9A

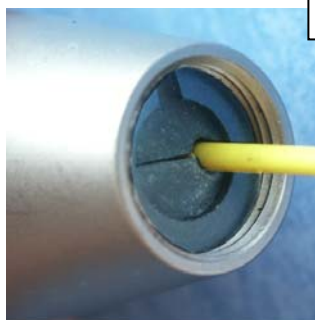

B0122AAA

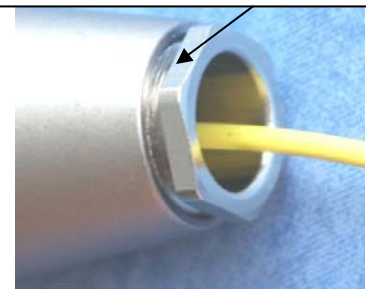

B0122ABA

8. Connect the plug to the optical-fibre connector of the Remote Unit, again by fitting a stamp on the plug into the groove of the connector.
9. To lock the connector, push the black locking ring forward.\*\*\*\*

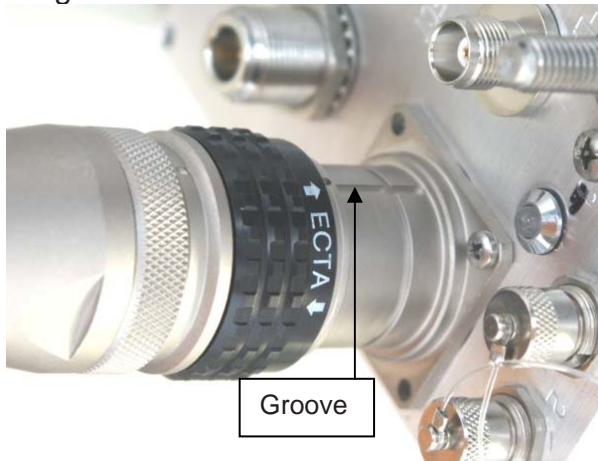

B0122ACA



B0122ADA

\*\*\* For disassembling, release the clamping ring and remove the seals and the plastic ring first.

\*\*\*\* Locking mechanism: The system of locking the plug is based on a “push-pull” mechanism. The locking ring has to be pushed forward to lock the connector and pulled back to free the connection.

### 3.5.2. Protective-Tube Kit

As additional protection for the optical fibers, this connector type can be supplemented by a special tube kit. To fasten the tube correctly, first unscrew the clamp ring (if already installed) of the original plug kit.

Then, proceed according to the following instruction:

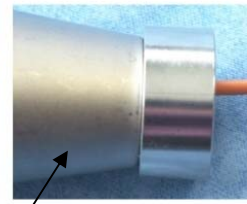

B0122AGA

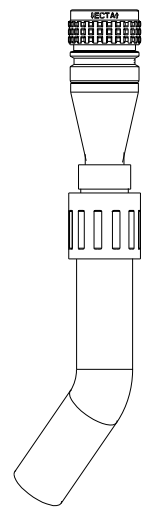
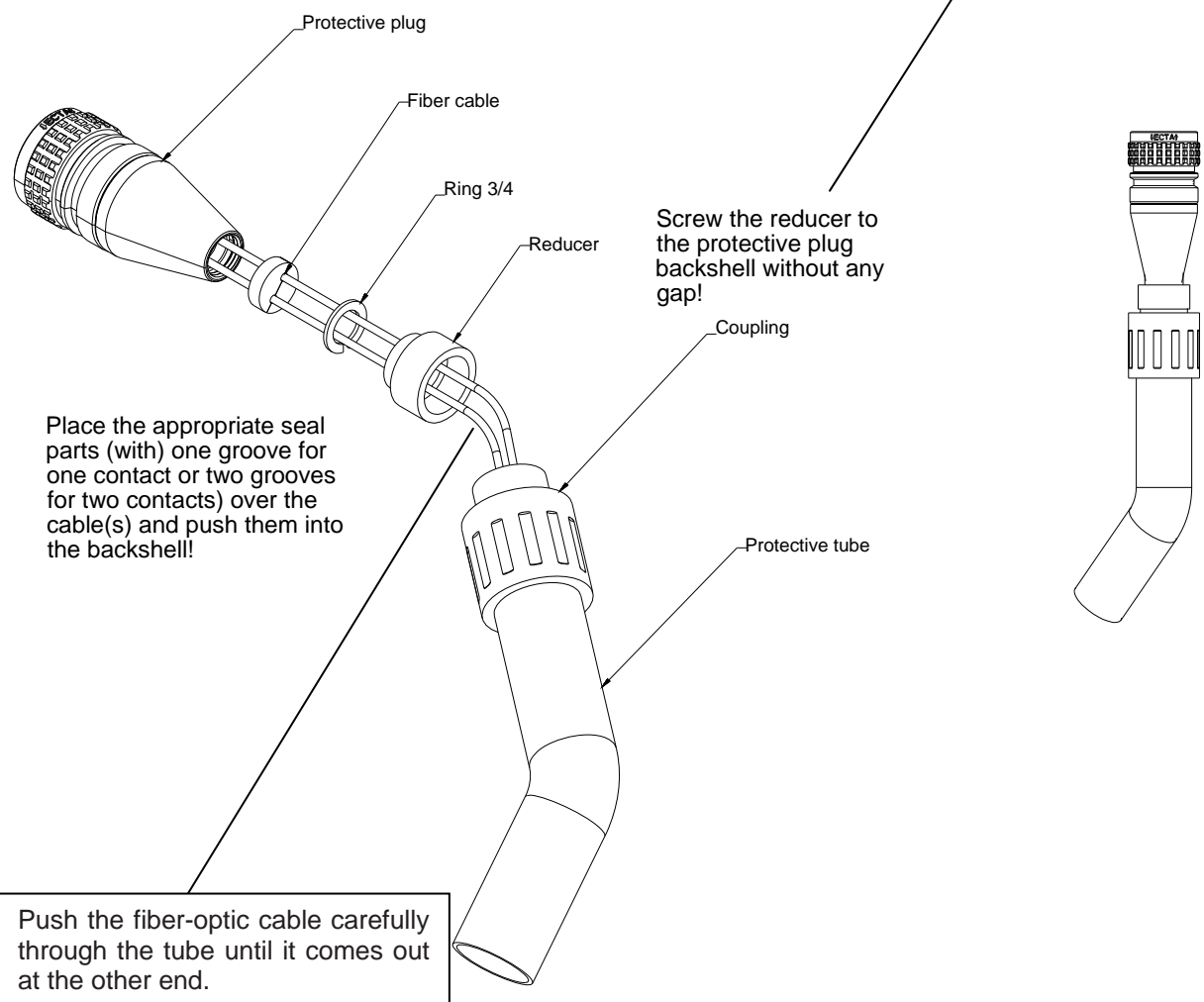

G1055M0

Push the fiber-optic cable carefully through the tube until it comes out at the other end.

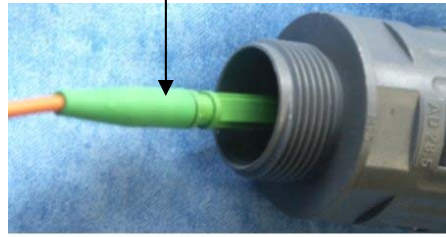

B0122AJA

figure 3-12 Tube-kit installation

### 3.6. COMMISSIONING

Read the health and safety warnings in chapter *1.2 Health and Safety Warnings* as well as the description carefully to avoid mistakes and proceed step by step as described!

- Do not operate the Remote Unit without terminating the antenna connectors. The antenna connectors may be terminated by connecting them to their respective antennas or to a dummy load.
- Only qualified personnel should carry out the electrical, mechanical, commissioning and maintenance activities that require the unit to be powered on when open.
- When opening the Remote Unit do not damage the warranty labels on the internal devices. The warranty is void if the seals are broken.
- Ensure that all connections have been performed according to chapter *3.2.2 Connections*.

# Commissioning an ION-M Remote Unit

Manual for Remote Unit

Philips screwdriver

Mounting kit  
Spanner, size 13 mm  
Drilling machine  
Dowels  
Screw driver

Screw driver  
Spanner, size 13 mm

Grounding cable  
Spanner 13 mm

Alarm kit  
(M-cabinet)



E2000 APC8° connector  
Spanner with opening 32

Mains cable  
Connecting kit

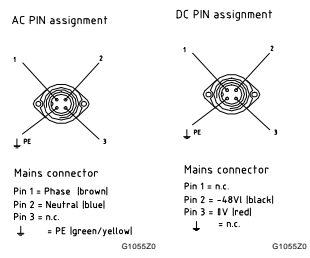
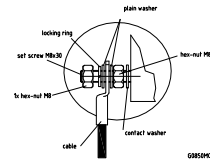
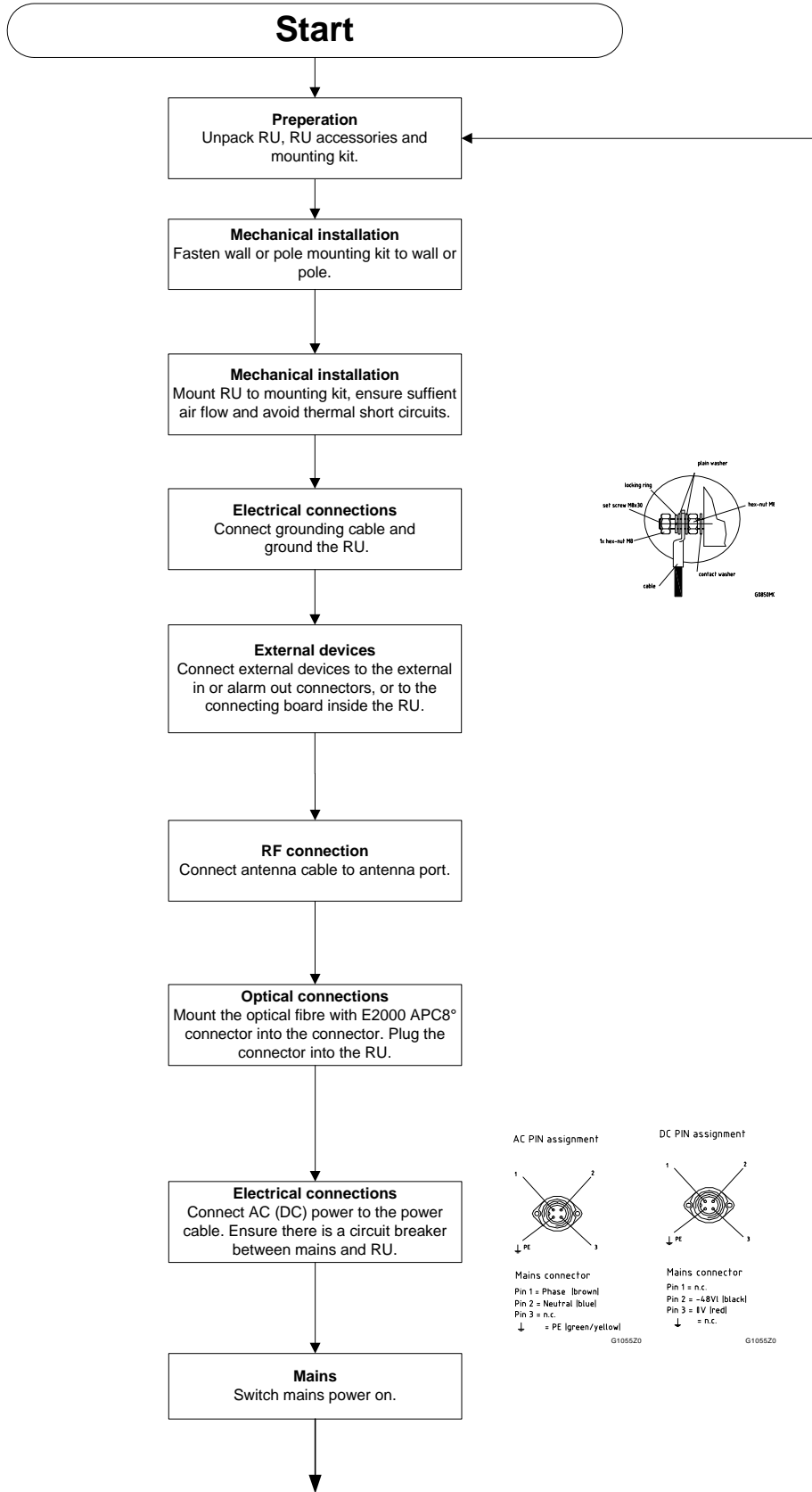



**For your notes:**

## **4. ALARMS**

### **4.1. BITe AND ALARMS**

The Built-In Test (BITe) concept comprises the monitoring of the power supplies, the power amplifiers and the optical interface.

All alarms occurring can be checked via software at the Master Unit.

### **4.2. HANDLING OF ALARMS**

A message is transmitted to the Master Unit when the software acknowledges a valid alarm.

A new alarm message will not be repeated if the reason for the alarm is cleared or if the alarm continues.

A new alarm message will be generated if the alarm is interrupted for at least five seconds after acknowledgement.

### **4.3. ALARM STATUS**

Refer to the corresponding software documentation of the Master Unit for details.

#### 4.4. STATUS LED ALARMS

For local supervision, a status LED on the connector flange of the remote unit gives an indication of possible reasons for alarms. This table shows possible on-site measures that could be checked before referring to the master unit alarm list.

<b>Status LED Indication</b>	<b>Alarms</b>	<b>Possible on-site measures</b>
Green	No alarm → Status ok	
Orange	Door alarm	Close the door (RUs with door).
	<i>Alarms not directly related to RU:</i>	
	External alarms	Check externally connected devices.
	Optical alarm Rx	Check fibre loss of optical link. Check optical connectors. Clean optical connectors. <i>(MU: Check optical output power of corresponding OTRx at master unit).</i>
	ALC alarm	<i>(MU: Decrease DL input power of affected band).</i>
Red	<i>Alarms directly related to RU:</i>	
	Power 28 V	Change power supply (RUs with door). Replace the affected remote unit.
	Temperature	Reduce environmental temperature. Eliminate thermal short circuit.
	Fan	Disconnect and connect mains. Fans should run. If not, replace the fans at RU.
	I <sup>2</sup> C	Disconnect and connect mains.
	Optical alarm Tx	Exchange RU.
	Amplifier “Power Down”	<i>(MU: Change amplifier setting at MU controller).</i>
Status LED off	Mains	Check power switch inside of RU (RUs with door). Check mains cabling. Check mains power.

*table 4-1 Status LED alarms*

For the position of the status LED see chapter 3.2.2 *Connections*.

Explicit troubleshooting is available in the MU software (software manual or WEB Interface).

## 4.5. EXTERNAL ALARM INPUTS AND OUTPUTS

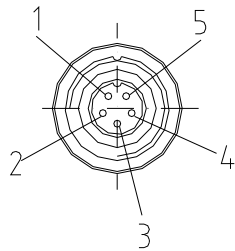

Flange connector  
5 poles

Pin 1= Alarm IN1  
Pin 2= Alarm IN2  
Pin 3= Alarm IN3  
Pin 4= Alarm IN4  
Pin 5= Alarm GND

G1038Z0

figure 4-1 Flange connector, 5 poles

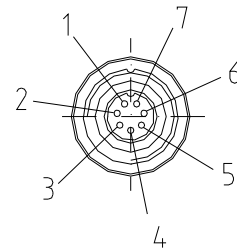

Flange connector  
7 poles

Pin 1= OUT1  
Pin 2= OUT2  
Pin 3= OUT3  
Pin 4= OUT4  
Pin 5= Alarm GND  
Pin 6= GND  
Pin 7= +28 V

G1038Z0

figure 4-2 Flange connector, 7 poles

The alarm outputs (open collector output 5 V / 1 mA) are normally low. In case of an alarm they are high active (5 V). They can be used to monitor alarms with an external alarm indicator.

The +28 V pin (for its location see *figure 4-2 Flange connector, 7 poles*) is protected by a 500 mA thermoswitch. In case of exceeding this current between PIN 7 and GND and/or in case of a failure of the VSWR module, the thermoswitch turns into a high-resistive status. In this case no fuse needs to be replaced. Just wait a few minutes until the thermoswitch reaches the normal operating temperature again.

**Note:** The manufacturer / supplier of this system accepts no liability for damage caused by equipment connected to external outputs or by effects from such equipment.

As accessory equipment the alarm kit is available to connect external devices to the external alarm inputs and outputs (for ID No see section 6.3 *Spare Parts*).

With the external alarm inputs it is possible to monitor the status of connected devices, e.g. a UPS, via software. All alarm inputs are normally high (5 V) without connection. The polarity (high/ low) can be set via the software at the Master Unit (for details please see according software manual).

The device to be monitored must be connected so that the alarm contacts will be closed in case of an alarm ( $I_{max} = 8 \text{ mA}$ ). The alarm inputs are potential-free with common ground.

Subminiature circular connectors series 712 with five and seven contacts, which are contained in the alarm kit, can be ordered directly from the Binder Connector Group, the manufacturer, or indirectly from Andrew Solutions (for ID No of the alarm kit see section 6.3 Spare Parts).

ION-M alarm outputs

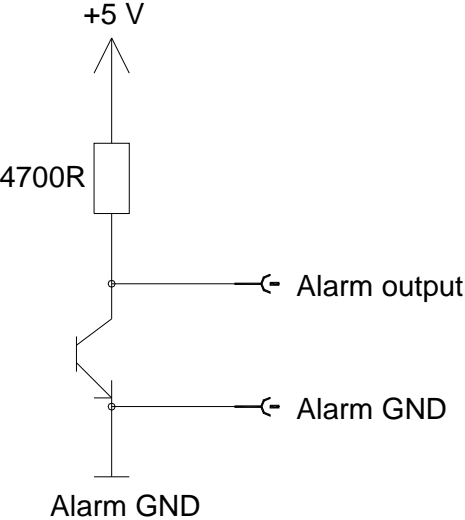

ION-M alarm inputs

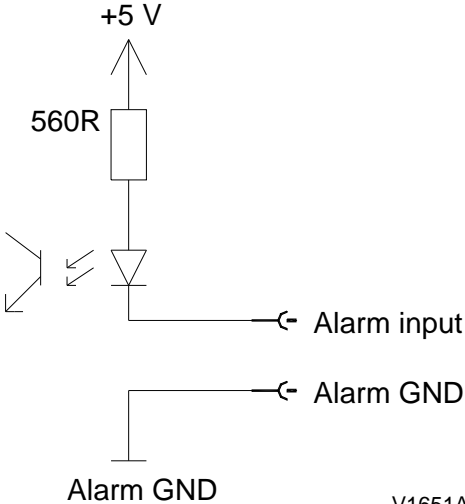

V1651A1

figure 4-3 Alarm inputs and outputs, standard

**4.6. TROUBLESHOOTING**

The status of the Remote Unit can be checked via the Master Unit (for details please refer to the software manual of the Master Controller). Locally, the status can be checked at the LED, see chapter 3.2.2 Connections.

## 5. MAINTENANCE

### 5.1. GENERAL

Read the health and safety warnings in chapter *1.2 Health and Safety Warnings*.

- ☞ **Note:** The Remote Unit does not require preventative maintenance measures.
- ☞ **Note:** To prevent malfunctions of the cooling system due to dirt or pollution, it is recommended to clean the heat sink at regular intervals. These cleaning intervals depend mainly on the location of the Remote Unit and the corresponding degree of pollution.

Maintenance of the ION-M7P should be performed by replacing only components that are contained in this chapter. In order to maintain warranty, take care not to damage unintentionally the seals on the modules.

The spare parts list, consequently, contains only units which can be replaced without tuning or soldering work.

- ☞ **Note:** When sending back the unit, use an appropriate packaging, see chapter *6.2.3 Environmental and Safety Specifications*. We strongly recommend using the original packaging!
- ☞ **Note:** Defect parts should only be replaced by original parts from the supplier. All interventions inside the housing are at one's own risk.
- ☞ **Note:** During maintenance ensure the Remote Unit has been disconnected from mains.
- ☞ **Note:** Before disconnecting any cables, label any unlabelled cables to ensure correct connection.

For most maintenance procedures appropriate tools are required to ensure correct handling. All these tools can be ordered from the supplier. For screwing procedures observe that all our screws have a right-hand thread, i.e. for fastening the screws turn the tool clockwise and for unscrewing them turn it counter-clockwise.

Due to the design of the Remote Unit the only component recommended to be replaced is the fan unit. For replacing any other component, please contact the supplier.

## 5.2. REPLACING THE FAN UNIT

Replacement of the fan unit is not required as a preventative measure. Only if an alarm indicates a malfunctioning of a fan must the unit be exchanged.

**Note:** Please observe that the fan unit can only be replaced as a whole. Do not remove the fans separately.

Read the health and safety warnings in chapter 1.2 *Health and Safety Warnings* as well as the instructions in chapter 5.1 *General* before starting with the replacement.

1. **Switch off the Remote Unit. Make sure mains is disconnected for the following replacement procedure.** Then, proceed as follows:

2. Loosen the four tallow-drop screws M4x8 by which the fan plate is screwed to the cabinet. Remove the four screws and the corresponding washers.



B0092ALA

3. Remove the fan unit – by putting slight pressure on the fan plate cover – to a position that allows access to the fan connector and the earth-bonding cable.

4. Unscrew the fan connector and then disconnect the earth-bonding cable.

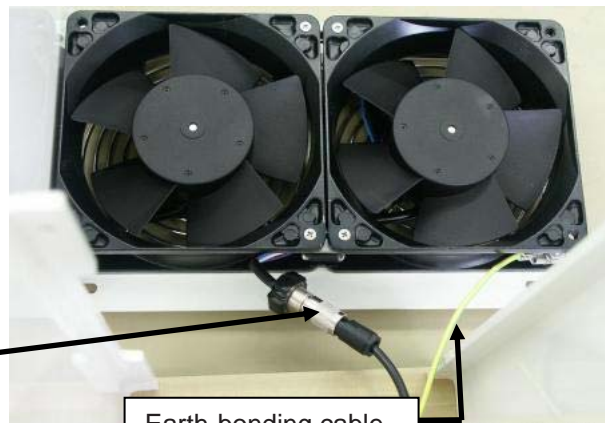

Fan-unit connector

Earth-bonding cable

B0092A5A

**Note:** To observe the specified torque of 650 Ncm for an M5 thread, use an appropriate tool for the following screwing procedures.

5. To mount the new fan unit, re-connect the earth-bonding cable and the fan connector (see *step 4*). Then, place the fan unit back into its original position and fix it tight as shown below:

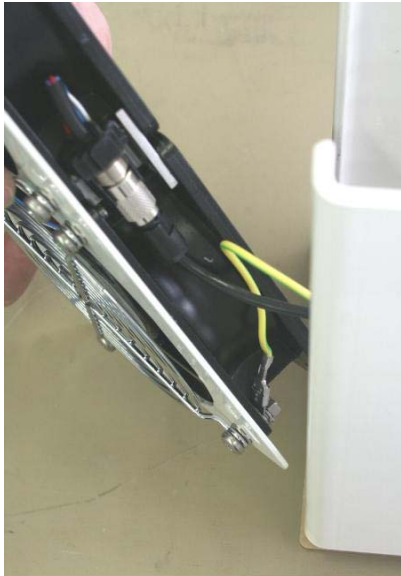

B0092AJA



B0097AKA

6. Screw the whole fan unit to the cabinet with the four tallow-drop screws M4x8 (see *step 2*). In order not to exceed the specified torque of 330 Ncm, use an appropriate tool.



### 5.3. CLEANING THE HEAT SINK

👉 **Note:** Read the health and safety warnings in chapter 1.2 *Health and Safety Warnings* as well as the instructions in chapter 5.1 *General* before starting with the replacement procedure. Then, proceed as follows:

1. Switch off the Remote Unit. For the following procedure ensure that mains has been disconnected before!
2. Remove the fan plate with the fan unit from the Remote Unit as described in chapter 5.2 *Replacing the Fan Unit*, steps 1 and 2:
3. Use compressed air (max. 5 bar) to blow out the heat sink from back to front:

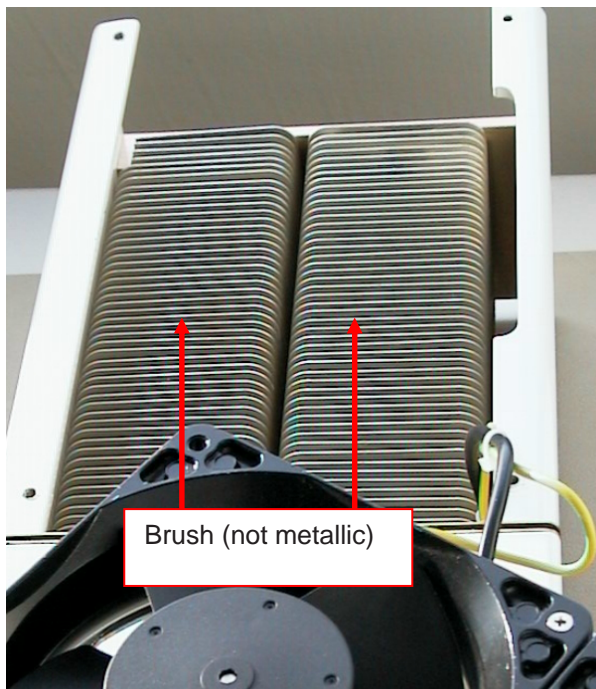

B0112A5A

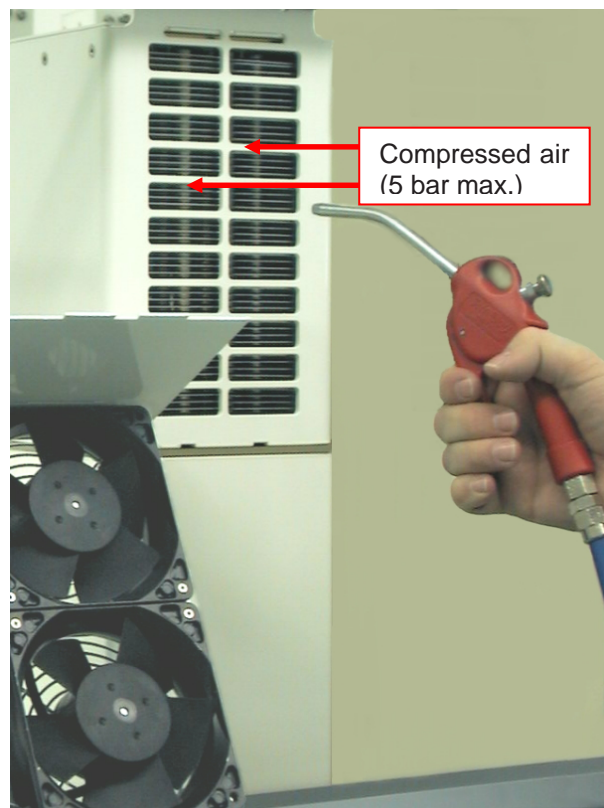

B0112A6A

4. In case the dirt cannot be blown out completely and parts of it stick to the ribs of the heat sink, clean the parts concerned carefully from the front using e.g. a brush. Take care that the material is not scratched or damaged.
5. After cleaning the heat sink, mount the fan unit again according to chapter 5.2 *Replacing the Fan Unit*, step 6. Then, switch the Remote Unit back on.

# 6. APPENDIX

## 6.1. ILLUSTRATIONS

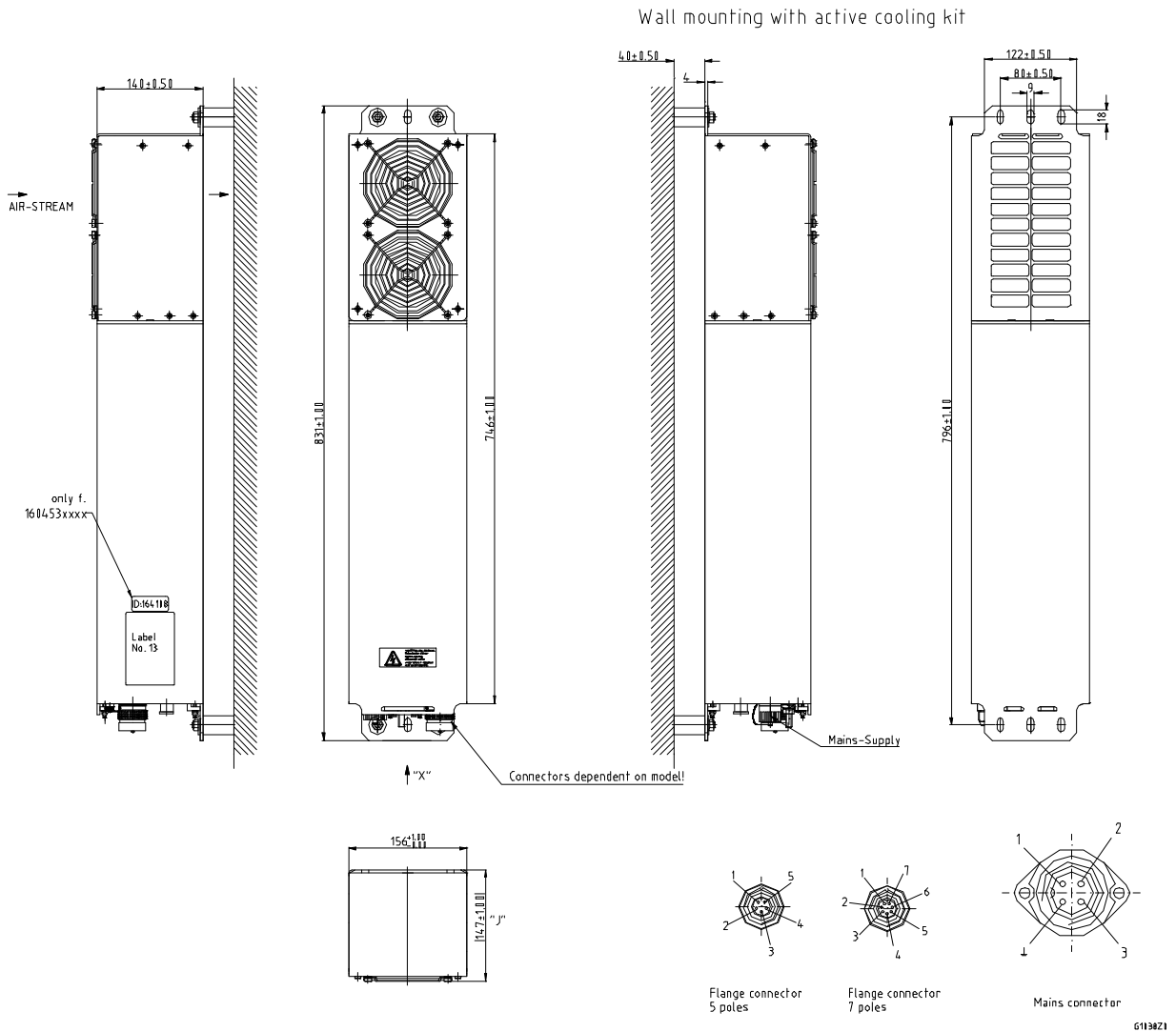

figure 6-1 Installation drawing

## 6.2. SPECIFICATIONS

### 6.2.1. Electrical Specifications

<b>ION-M7P</b>		
<b>Electrical</b>		
Power supply	Mains power	85 Vac to 264 Vac 115 Vac or 230 Vac
Power consumption		300 Watts
<b>Optical</b>		
Connectors		E2000/APC 8°
Optical return loss		45 dB minimum
Fiber type		Single mode E9/125 mm
Optical link budget		0 to 10 dB
Composite input power @ OTRx master side		700 MHz      3.0 dBm composite

**All data is subject to change without notice.**

### 6.2.2. Mechanical Specifications

Height, width, depth *	831 x 156 x 147 mm (32.7 x 6.1 x 5.8 in)
Weight	20 kg (44.1 lb)

\* A spacing of 40 mm (1.66 inch) around the unit is required.

**All data is subject to change without notice.**

### 6.2.3. Environmental and Safety Specifications

 **Note:** For detailed information, please refer to the Environmental and Safety Specifications leaflet of the supplier, related to ETS 300 019 (European Telecommunication Standard).

Operating temperature range		-33°C to +50°C
Ingress protection	RF part	IP67
	Fan part	IP55

**All data is subject to change without notice.**

### 6.3. SPARE PARTS

The following lists contain all parts available for the Remote Unit. The configuration of the delivered unit meets the requirements of the customer and can differ depending on the state of the delivery.

Maintenance of the ION-M7P should be performed on an FRU (Field Replaceable Unit) basis only. The following spare parts lists only contain units that can be replaced without tuning or soldering work. To replace an FRU, use the appropriate tools. Replacement tools may be ordered from the supplier. If any FRU not contained in the following list needs to be replaced, please contact customer service for additional instructions.

#### Spare Parts List of the Remote Unit ION-M7P

<b>Designation:</b>	<b>ID No:</b>	<b>FRU</b>
<b><i>ION-M7P</i></b>	<b><i>7622613</i></b>	
Protective Plug E2000	7160013	x
Protective Cap E 2000	7158914	x
Fan Protection Kit	7159097	x
Fan Unit	7158254	x
Protective Tube Kit	7162182	x
Manuals für ION-M7P	7624540-00	

<b>Accessories</b>	
<i>Wall Mounting</i>	
Wall-Mounting Kit	7158078
ISO Trafo Kit 115 V Wall Mounting	7159340
ISO Trafo Kit 230 V Wall Mounting	7158322
Connecting Box Kit Wall Mounting	7159613
Overcoat Housing Kit Wall Mounting	7159625
<i>Pole Mounting</i>	
Pole-Mounting Kit	7157782
ISO Trafo Kit 115 V Pole Mounting	7159623
ISO Trafo Kit 230 V Pole Mounting	7159621
Connecting Box Kit Pole Mounting	7159612
Overcoat Housing Kit Pole Mounting	7159624
Alarm Kit	7157396

The manufacturer reserves the right to replace the spare parts listed above by equivalent substitutes.

## 7. INDEX

<b>A</b>		<b>H</b>	
Abbreviations .....	7	Health and Safety Warnings .....	8
Address of Andrew Wireless Systems GmbH.....	12		
Alarms			
Alarm Status .....	34		
Bite and Alarms .....	34		
External Inputs.....	36, 37		
Handling of Alarms .....	34		
List .....	37		
Outputs .....	36, 37		
RU .....	37		
Status LED.....	35		
Andrew Solutions.....	10		
<b>C</b>		<b>I</b>	
Cleaning the Heat Sink .....	41	Illustrations .....	42
Commissioning		Installation	
General .....	31	Electrical .....	20
Components		Mechanical .....	15
Accessories .....	14		
Fan-Protection Kit .....	14		
Connection Rules			
Optical-Fiber Cables .....	25		
Connections			
Antenna .....	23		
Connector Flange .....	21		
Power .....	24		
Contact Addresses .....	11		
Control Connector for EU .....	22		
Customer Support Addresses.....	11		
<b>E</b>		<b>M</b>	
Extension Unit		Maintenance .....	38
RS485/ RS232 Control Connector (8 PINs)....	22	Mounting	
External Inputs		Fan Protection .....	19
Location .....	21	Pole (Outside).....	17
		Wall.....	16
<b>F</b>		<b>O</b>	
Fiber-Optical Components		Optical-Fibre Connection	
Cleaning Procedure .....	26	Protective Plug .....	27
System Installation.....	25	Protective-Tube Kit .....	29
Flange Connector		Outputs	
5 poles .....	36	Location .....	21
7 poles .....	36		
<b>G</b>		<b>P</b>	
Grounding.....	22	Pin Assignment	
		External Alarms .....	36
		<b>R</b>	
		Replacement of Fan Unit.....	39
		RS485/ RS232 EU Control Connector .....	22
		<b>S</b>	
		Spare Parts .....	44
		Specifications	
		Electrical .....	43
		Environmental and Safety.....	43
		Mechanical .....	43
		<b>T</b>	
		Troubleshooting.....	37

**For your notes:**