

Test Site:
FCC Test Site No.:
IC OATS No.:

96997
IC3475A-1



ECL-EMC Test Report No.: 11-013

Equipment under test: ION-M7P/7P 2x 700MHz Path
FCC ID: XS5-ION-M77PMU
IC ID: 2237E-IONM77PMU
Type of test: **FCC 47 CFR Part 27 Subpart H, F, :2009**
Miscellaneous Wireless Communication Services
IC RSS-131:2003
Zone Enhancers for the Land Mobile Service

Measurement Procedures: 47 CFR Parts 2:2009 (*Frequency Allocations and Radio Treaty Matters; General Rules and Regulations*), Part 27:2009 (*Miscellaneous Wireless Communication Services*), ANSI/TIA-603-C:2004, *Land Mobile FM or PM Communications Equipment Measurement and Performance Standards*
IC-GEN:2007 General Requirements and Information for the Certification of Radiocommunication Equipment

Test result: **Passed**

Date of issue:	24.01.11			Signature:
Issue-No.:	02	Author:	Tom Zahlmann Test engineer	
Date of delivery:	25.01.11	Checked:	M. Lehmann EMV-Leiter Head of EMC	
Test dates:	13.12. – 24.01.11			
Pages:	38			

Test Report No.: 11-013

FCC ID: XS5- ION-M77PMU

IC ID: 2237E-IONM77PMU



Manufacturer: ANDREW Wireless Systems GmbH
Industriering 10

D-86675 Buchdorf

Tel.: +49 (0)9099 69 0

Fax: +49 (0)9099 69 140

Test Location: TEMPTON Service Plus GmbH
European Compliance Laboratory (ECL)

Thurn-und-Taxis-Straße 18

D-90411 Nürnberg

Tel.: +49 (0) 911 59835 0

Fax: +49 (0) 911 59835 90

General:

The purpose of this report is to show compliance to the FCC regulations for devices operating under Part 27 of the Code of Federal Regulations title 47.

This report informs about the results of the EMC tests, it only refers to the equipment under test. No part of this report may be reproduced in any form, without written permission.



Table of contents

1	TEST RESULTS SUMMARY	5
2	EQUIPMENT UNDER TEST (E.U.T.)	6
2.1	DESCRIPTION	6
2.1.1	DOWNLINK	6
2.1.2	UPLINK	6
2.1.3	DESCRIPTION OF EUT	6
2.1.4	SYSTEM DIAGRAM OF EUT	7
2.1.5	BLOCK DIAGRAM OF MEASUREMENT REFERENCE POINTS	7
3	TEST SITE (ANDREW BUCHDORF)	8
3.1	TEST ENVIRONMENT	8
3.2	TEST EQUIPMENT	8
3.3	INPUT AND OUTPUT LOSSES	8
3.4	MEASUREMENT UNCERTAINTY	8
4	TEST SITE (TEMPTON)	9
5	RF POWER OUT: §27.50, §2.1046; RSS-131, RSS-GEN	10
5.1	LIMIT	10
5.2	TEST METHOD	10
5.3	TEST RESULTS	11
5.3.1	DOWNLINK	11
5.3.1.1	LTE 728 – 746MHz, MAIN	12
5.3.1.2	LTE 746 – 757MHz, MAIN	12
5.3.1.3	LTE 728 – 746MHz, MIMO	13
5.3.1.4	LTE 746 – 757MHz, MIMO	13
5.3.2	UPLINK	14
5.4	SUMMARY TEST RESULT	14
6	OCCUPIED BANDWIDTH: §90.210, §2.1049; RSS-GEN	15
6.1	LIMIT	15
6.2	TEST METHOD	15
6.3	TEST RESULTS	15
6.3.1	DOWNLINK	15
6.3.1.1	LTE 728 – 746MHz MAIN	16
6.3.1.2	LTE 746 – 757MHz MAIN	17
6.3.1.3	LTE 728 – 746MHz MIMO	18
6.3.1.4	LTE 746 – 757MHz MIMO	19
	UPLINK	20
6.4	SUMMARY TEST RESULT	20
7	SPURIOUS EMISSIONS AT ANTENNA TERMINALS: §27.53, §2.1051; RSS-131, RSS-GEN	21
7.1	LIMIT	21
7.2	TEST METHOD	21



7.3	TEST RESULTS	22
7.3.1	DOWNLINK	22
7.3.1.1	LTE < 1MHz to band edge 728 – 746MHz, MAIN	24
7.3.1.2	LTE < 1MHz to band edge 746 – 757MHz, MAIN	25
7.3.1.3	LTE < 1MHz to band edge 728 – 746MHz, MIMO	26
7.3.1.4	LTE < 1MHz to band edge 746 – 757MHz, MIMO	27
7.3.1.5	LTE > 1MHz to band edge 728 – 746MHz, MAIN	28
7.3.1.6	LTE > 1MHz to band edge 746 – 757MHz, MAIN	28
7.3.1.7	LTE > 1MHz to band edge 728 – 746MHz, MIMO	29
7.3.1.8	LTE > 1MHz to band edge 746 – 757MHz, MIMO	29
7.3.2	UPLINK	30
7.4	SUMMARY TEST RESULT	30
8	RADIATED SPURIOUS EMISSIONS AT THE ECL (TEMPTON): §27.53, §2.1053, RSS-GEN, RSS-131 31	
8.1	METHOD OF MEASUREMENT.....	34
8.2	LIMIT.....	35
8.3	RECEIVER SETTINGS	35
8.4	CLIMATIC VALUES IN THE LAB.....	35
8.5	TEST RESULTS	36
8.5.1	30 MHz TO 1 GHz DOWNLINK (<u>B</u> OTTOM – <u>M</u> IDDLE – <u>T</u> OP) SUBPART H.....	36
8.5.2	30 MHz TO 1 GHz DOWNLINK (<u>B</u> OTTOM – <u>M</u> IDDLE – <u>T</u> OP) SUBPART F	36
8.5.2.1	1 GHz to 8 GHz Downlink (<u>B</u> ottom – <u>M</u> iddle – <u>T</u> op) Subpart H.....	37
8.5.2.2	1 GHz to 8 GHz Downlink (<u>B</u> ottom – <u>M</u> iddle – <u>T</u> op) Subpart F	37
9	HISTORY.....	38



1 Test Results Summary

Name of Test	FCC Para. No.	FCC Method	FCC Spec.	Result
RF Power Output	27.50(b)(c)	2.1046	1000 Watts ERP	Complies
Occupied Bandwidth	2.1049	2.1049	Input/Output	Complies
Spurious Emissions at Antenna Terminals	27.53(c)(d)(g)	2.1051	-13dBm	Complies
Radiated Spurious emission	27.53(m)	2.1053 TIA/EA-603	-13dBm E.I.R.P	Complies
Frequency Stability	27.54	2.1055	Must stay in band	NA

Name of Test	IC Para. No.	IC Method	Result
RF Power Output	RSS-131 6.2	RSS-GEN 4.8	Complies
Occupied Bandwidth	RSS-Gen 6.3	RSS-GEN 4.6.1	Complies
Spurious Emissions at Antenna Terminals	RSS-131 6.4	RSS-GEN 4.9	Complies
Field Strength of Spurious Emissions	RSS-131 6.4	RSS-GEN 4.9 SRSP-513	Complies
Frequency Stability	RSS-131 6.5	RSS-GEN 4.7	NA

Frequency stability is not applicable because the device uses a common oscillator to up convert and down convert the RF signal. The EUT does not contain modulation circuitry, or frequency generation, therefore the test was not performed.



2 Equipment under test (E.U.T.)

2.1 Description

Kind of equipment	ION-M7P/7P	
Andrew Ident. Number	Id.No. 7604900-0001	
Serial no.(SN)	13	
Revision	00	
Software version and ID	n. a.	
Type of modulation and Designator	LTE (G7D)	<input checked="" type="checkbox"/>
Frequency Translation	F1-F1	<input checked="" type="checkbox"/>
	F1-F2	<input type="checkbox"/>
	N/A	<input type="checkbox"/>
Band Selection	Software	<input type="checkbox"/>
	Duplexer	<input checked="" type="checkbox"/>
	Full band	<input type="checkbox"/>

2.1.1 Downlink

Pass band	Path 728 MHz – 757 MHz
Max. composite output power based on one carrier per path (rated)	43 dBm = 20 W
Gain	36 dB

2.1.2 Uplink

Pass band	n. a.
Gain	n. a.

Note: The EUT does not transmit over the air in the uplink direction.

2.1.3 Description of EUT

ION-M7P/7P is a LTE MIMO multi-operator Remote Unit with various Extension Units. It is used in conjunction with a Master Unit in the ION optical distribution system. This system transports multiple LTE channels simultaneously (700 MHz, LTE), providing a cost-effective solution for distributing capacity from one or more base stations.

This Test Report describes only the approval of the Cellular 700 MHz range 728 MHz – 757 MHz. The ION-M7P/7P Repeater consists of two identical paths with one antenna port each. Each path covers Cellular 700 and LMR700, with the intended use of simultaneous transmission

2.1.4 System diagram of EUT

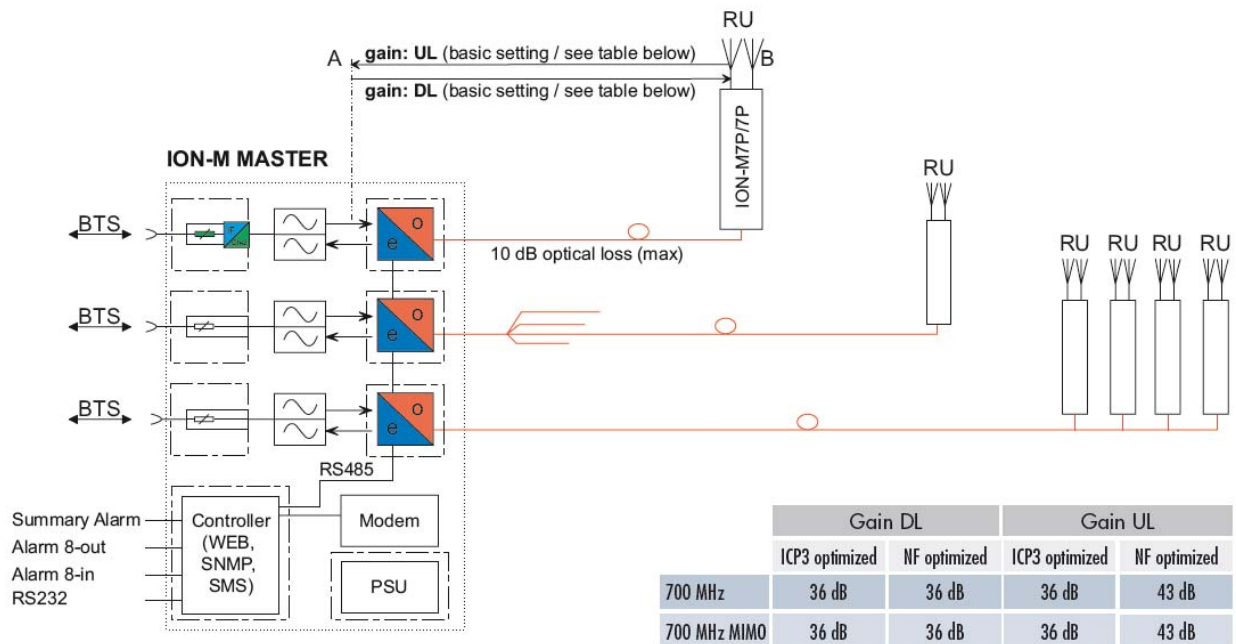

figure 2.1.4-#1 System diagram of EUT: ION-M7P/7P

Since a signal generator does not supply a good output signal with +33 or +43 dBm, for the downlink measurement the MU Attenuation is not used.

That means for downlink measurements the signal generator is connected to measurement point A at the master optical / electrical converter and the analyzer to the measurement point B at the RU.

2.1.5 Block diagram of measurement reference points

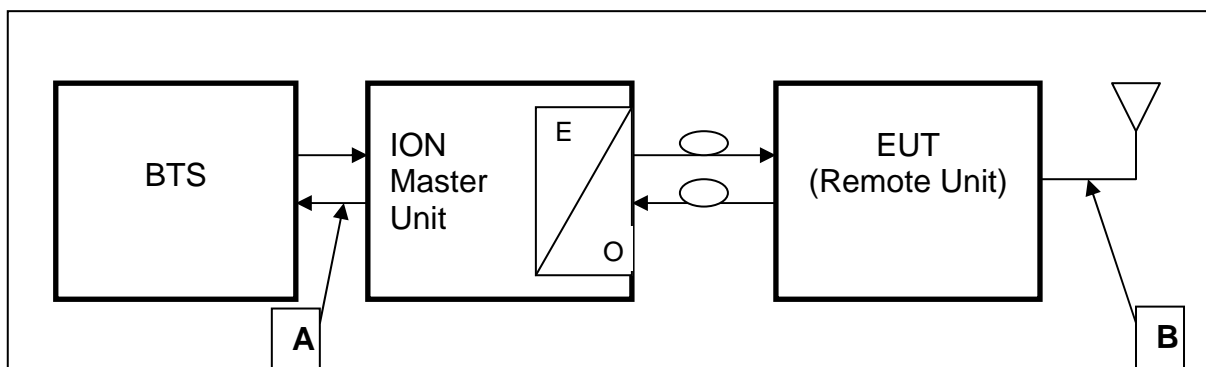

figure 2.1.5-#1 Block diagram of measurement reference points

Reference point B, Mobile: Optical DAS DL output, UL input
 Reference point A, BTS: Optical DAS UL output, DL input



3 Test site (Andrew Buchdorf)

3.1 Test environment

All tests were performed under the following environmental conditions:

Condition	Minimum value	Maximum value
Barometric pressure	86 kPa	106 kPa
Temperature	15°C	30°C
Relative Humidity	20 %	75 %
Power supply range	±5% of rated voltages	

3.2 Test equipment

ANDREW Inv. No.	Test equipment	Type	Manufacturer	Serial No.	Calibration
8372	Network Analyzer	8753D	HP	3410A08675	02/11
8961	Spectrum Analyzer	FSP-13	R&S	100147/013	10/11
8849	Signal Generator	SMU200A	R&S	101732	04/11
7192	Power Attenuator	769-30	Narda	07448	CIU
7119	Divider	2way	Mikom	3512	CIU
7287	RF-Cable	2,0m; N-N	Huber & Suhner	28441/4PEA	CIU
7288	RF-Cable	2,0m; N-N	Huber & Suhner	28442/4PEA	CIU
7391	RF-Cable	1,0m; SMA	Huber & Suhner	40447/4P	CIU

CIU = Calibrate in use

3.3 Input and output losses

All recorded power levels should be referenced to the input and output connectors of the repeater, unless explicitly stated otherwise.

The test equipment used in this test has to be calibrated, so that the functionality is also checked.

All cables, attenuators, splitter, isolator, circulator and combiner etc. must be measured before testing and used for compensation during testing.

3.4 Measurement uncertainty

The extended measurement uncertainty corresponds to the measurement results from the standard measurement uncertainty multiplied by the coverage factor $k=2$. The true value is located in the corresponding interval with a probability of 95 %.

Test Report No.: 11-013

FCC ID: XS5- ION-M77PMU

IC ID: 2237E-IONM77PMU



4 Test site (TEMPTON)

FCC Test site: 96997

IC OATS: IC3475A-1

See relevant dates under section 8 of this test report.



5 RF Power Out: §27.50, §2.1046; RSS-131, RSS-GEN

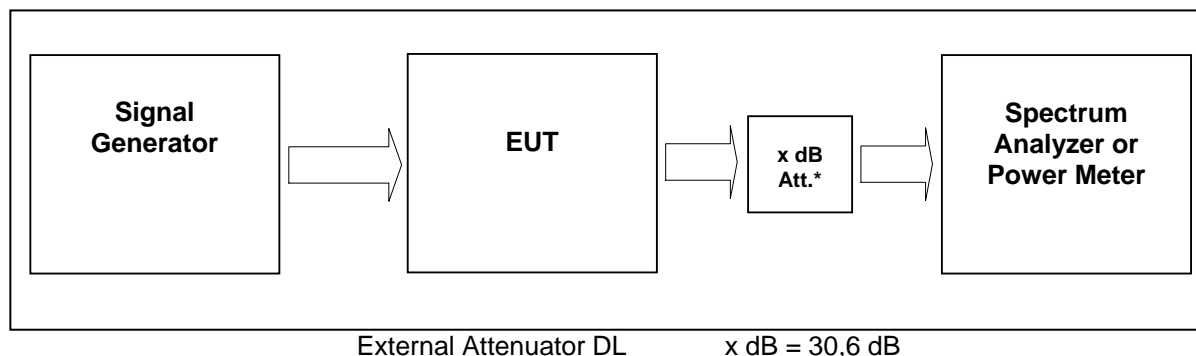

figure 5-#1 Test setup: RF Power Out: §27.50, §2.1046; RSS-131, RSS-GEN

Measurement uncertainty	± 0,38 dB
Test equipment used	8372, 8961, 8849, 7192, 7287, 7288, 7391

5.1 Limit

Minimum standard:

Para. No.27.50(b)(2), (c)(1)(3)

(b) The following power and antenna height limits apply to transmitters operating in the 746–763 MHz, 775–793 MHz and 805–806 MHz bands:

(2) Fixed and base stations transmitting a signal in the 746–757 MHz, 758–763 MHz, 776–787 MHz, and 788–793 MHz bands with an emission bandwidth of 1 MHz or less must not exceed an ERP of 1000 watts and an antenna height of 305 m HAAT, except that antenna heights greater than 305 m HAAT are permitted if power levels are reduced below 1000 watts ERP in accordance with Table 1 of this section. Para. No.27.50(c)(1 and 3)

(c) The following power and antenna height requirements apply to stations transmitting in the 698–746 MHz band:

(1) Fixed and base stations transmitting a signal with an emission bandwidth of 1 MHz or less must not exceed an effective radiated power (ERP) of 1000 watts and an antenna height of 305 m height above average terrain (HAAT), except that antenna heights greater than 305 m HAAT are permitted if power levels are reduced below 1000 watts ERP in accordance with Table 1 of this section;

(3) Fixed and base stations transmitting a signal with an emission bandwidth greater than 1 MHz must not exceed an ERP of 1000 watts/MHz and an antenna height of 305 m HAAT, except that antenna heights greater than 305 m HAAT are permitted if power levels are reduced below 1000 watts/MHz ERP in accordance with Table 3 of this section;

5.2 Test method

§ 2.1046 Measurements required: RF power output.

(a) For transmitters other than single sideband, independent sideband and controlled carrier radiotelephone, power output shall be measured at the RF output terminals when the transmitter is adjusted in accordance with the tune-up procedure to give the values of current and voltage on the circuit elements specified in § 2.1033(c)(8). The electrical characteristics of the radio frequency load attached to the output terminals when this test is made shall be stated.



(c) For measurements conducted pursuant to paragraphs (a) and (b) of this section, all calculations and methods used by the applicant for determining carrier power or peak envelope power, as appropriate, on the basis of measured power in the radio frequency load attached to the transmitter output terminals shall be shown. Under the test conditions specified, no components of the emission spectrum shall exceed the limits specified in the applicable rule parts as necessary for meeting occupied bandwidth or emission limitations

5.3 Test Results

Detector RMS.

Test signal LTE:

Signal waveform according to Test Model 1.1, E-TM1.1, clause 6.1.1.1-1, table 6.1.1.1-1 of standard specification 3GPP TS 36.141 V9.3.0 (2010-03).

5.3.1 Downlink

Modulation	Measured at	Path	RBW VBW Span	RF Power (dBm)	RF Power (W)	Plot #
LTE	Middle	737 MHz, MAIN Band 12	3MHz 10MHz 50MHz	43,0	20	5.3.1.1 #1
LTE	Middle	751,5 MHz, MAIN Band 13	3MHz 10MHz 50MHz	43,0	20	5.3.1.2 #1
LTE	Middle	737 MHz, MIMO Band 12	3MHz 10MHz 50MHz	43,0	20	5.3.1.3 #2
LTE	Middle	751,5 MHz, MIMO Band 12	3MHz 10MHz 50MHz	43,0	20	5.3.1.4 #2
Maximum output power = 43,0 dBm = 20 W						
Limit Maximum output power = 1000 W						

table 5.3.1-#1 RF Power Out: §27.50, §2.1046; RSS-131, RSS-GEN Test Results Downlink

Modulation	Pin / dBm (Ref. point B)
LTE	3,7
LTE	4,2
LTE	4,3
LTE	4,2

table 5.3.1-#2 RF Power Out: §27.50, §2.1046; RSS-131, RSS-GEN Test Results Downlink Input power



5.3.1.1 LTE 728 – 746MHz, MAIN

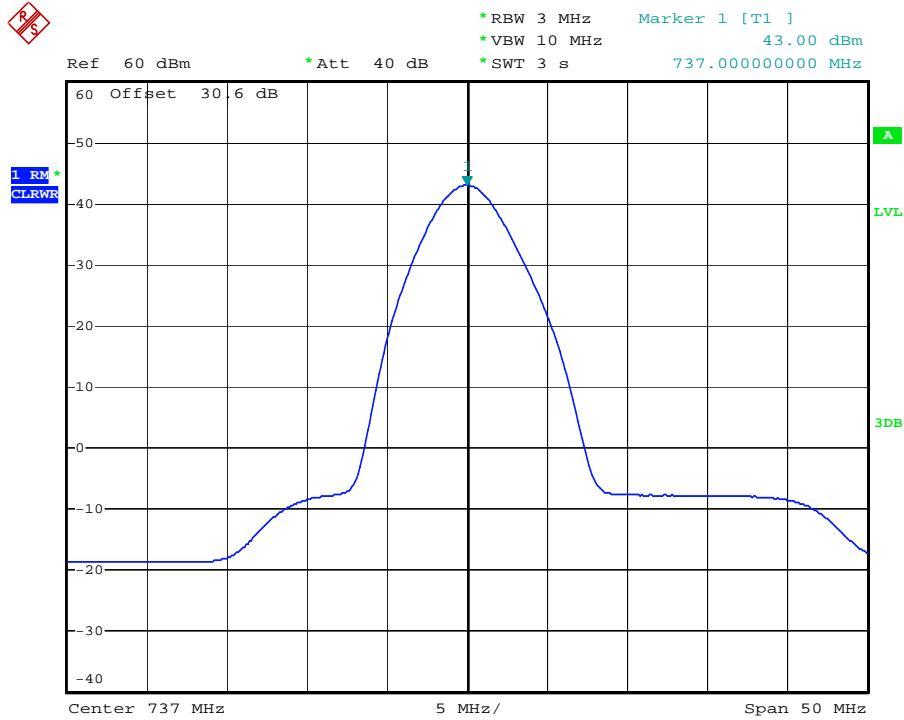

plot 5.3.1.1-#1 RF Power Out: §27.50, §2.1046; RSS-131, RSS-GEN; Test Results; Downlink; LTE 728 – 746MHz, MAIN Middle

5.3.1.2 LTE 746 – 757MHz, MAIN

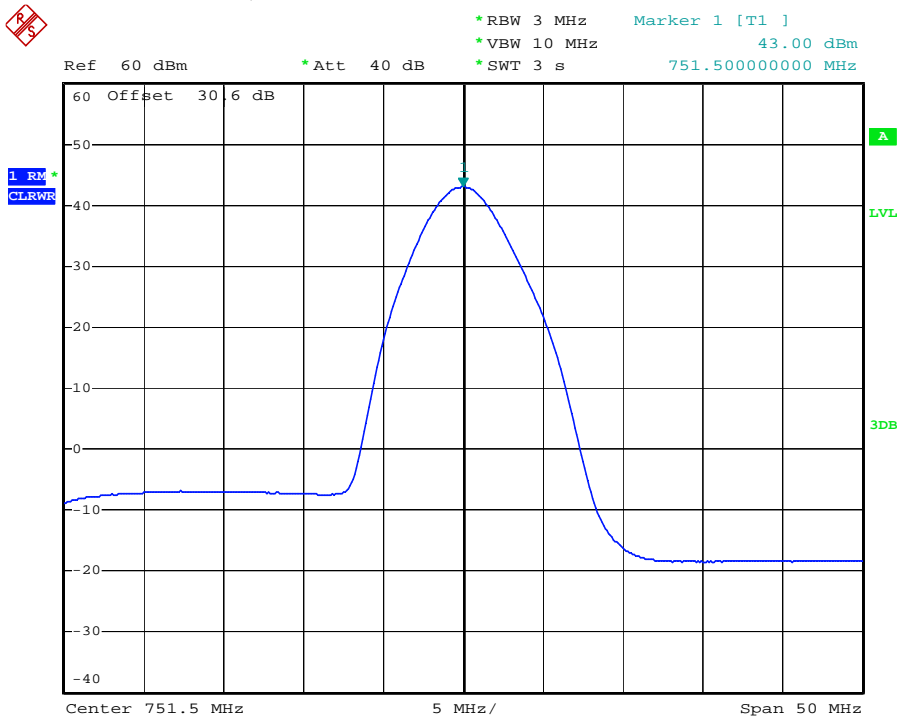

plot 5.3.1.2-#1 RF Power Out: §27.50, §2.1046; RSS-131, RSS-GEN; Test Results; Downlink; LTE 746 – 757MHz, MAIN Middle



5.3.1.3 LTE 728 – 746MHz, MIMO

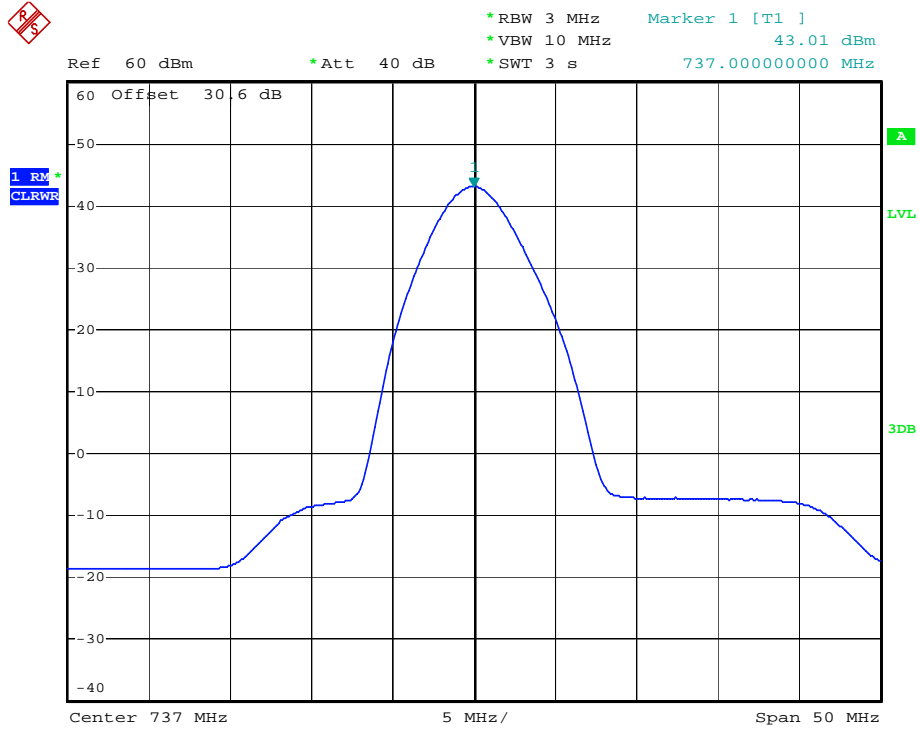

plot 5.3.1.3-#2 RF Power Out: §27.50, §2.1046; RSS-131, RSS-GEN; Test Results; Downlink; LTE 728 – 746MHz, MIMO Middle

5.3.1.4 LTE 746 – 757MHz, MIMO

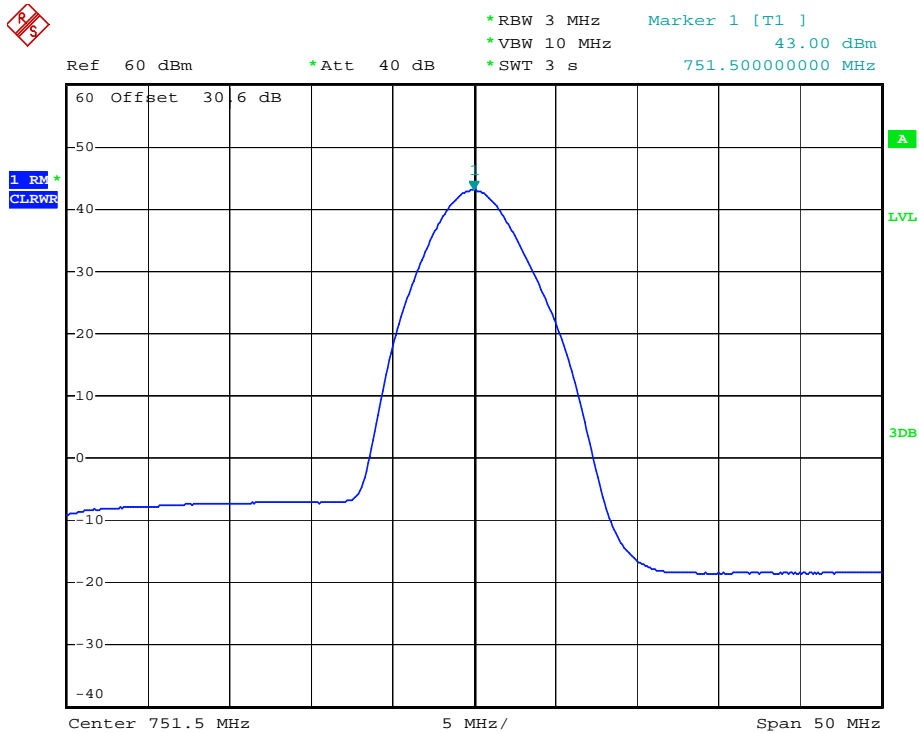

plot 5.3.1.4-#2 RF Power Out: §27.50, §2.1046; RSS-131, RSS-GEN; Test Results; Downlink; LTE 746 – 757MHz, MIMO Middle

Test Report No.: 11-013

FCC ID: XS5- ION-M77PMU

IC ID: 2237E-IONM77PMU



5.3.2 Uplink

n.a.

Note: The EUT does not transmit over the air in the uplink direction.

5.4 Summary test result

Test result	complies, according the plots above
Tested by:	L.Oskerko
Date:	13.12.2010



6 Occupied Bandwidth: §90.210, §2.1049; RSS-GEN

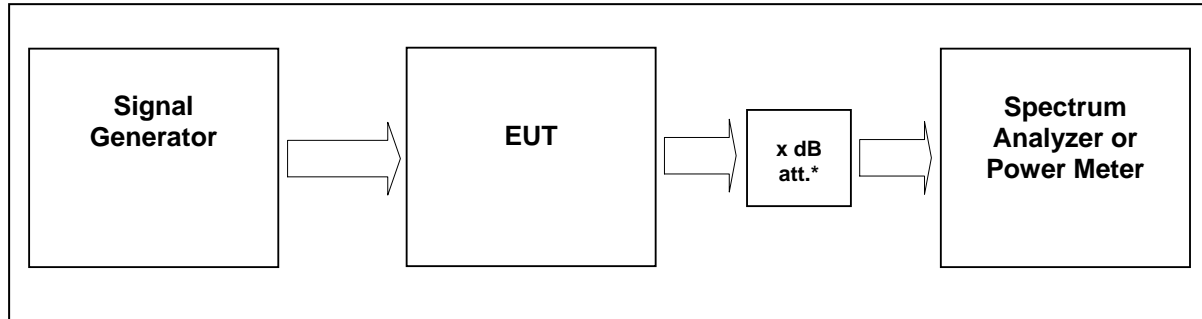

External Attenuator DL x dB = 30,6 dB
figure 6-#1 Test setup: Occupied Bandwidth: §90.210, §2.1049; RSS-GEN

Measurement uncertainty	± 0,38 dB
Test equipment used	8372, 8961, 8849, 7192, 7287, 7288, 7391

6.1 Limit

The spectral shape of the output should look similar to input for all modulations.

6.2 Test method

Para. No.2.1049

The occupied bandwidth, that is the frequency bandwidth such that, below its lower and above its upper frequency limits, the mean powers radiated are each equal to 0.5 percent of the total mean power radiated by a given emission shall be measured under the following conditions as applicable:

6.3 Test results

6.3.1 Downlink

Detector RMS.

Modulation	Measured at	Path	RBW VBW Span	Occupied Bandwidth / kHz	Plot #
LTE	Middle	737 MHz, MAIN	30 kHz 300 kHz 5 MHz	1100	6.3.1.1 #1,#2
LTE	Middle	751,5 MHz, MAIN	30 kHz 300 kHz 5 MHz	1100	6.3.1.2 #1,#2
LTE	Middle	737 MHz, MIMO	30 kHz 300 kHz 5 MHz	1100	6.3.1.3. #1,#2
LTE	Middle	751,5 MHz, MIMO	30 kHz 300 kHz 5 MHz	1100	6.3.1.4 #1,#2

table 6.3-#1 Occupied Bandwidth: §90.210, §2.1049; RSS-GEN Test results



6.3.1.1 LTE 728 – 746MHz MAIN

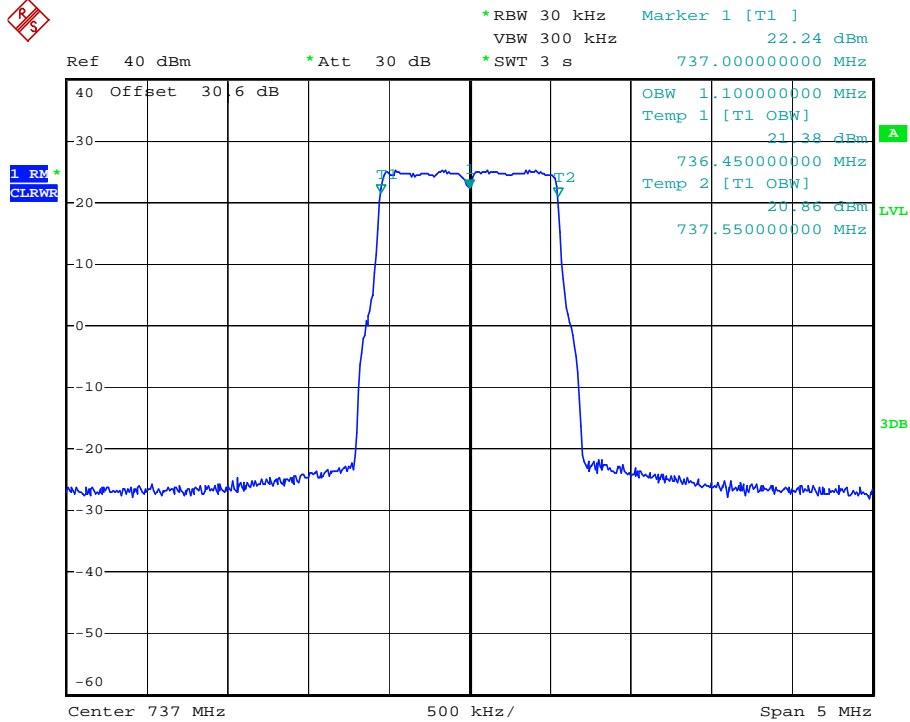

plot 6.3.1.1-#1 Occupied Bandwidth: §90.210, §2.1049; RSS-GEN; Test results; Downlink; LTE 728 – 746MHz MAIN Output

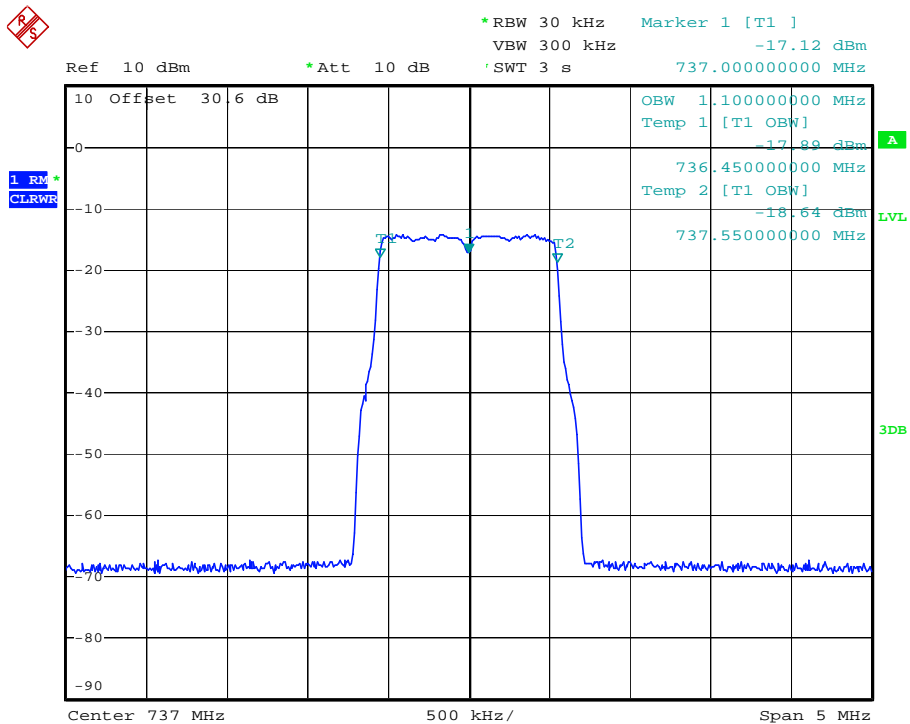

plot 6.3.1.1-#2 Occupied Bandwidth: §90.210, §2.1049; RSS-GEN; Test results; Downlink; LTE 728 – 746MHz MAIN Input



6.3.1.2 LTE 746 – 757MHz MAIN

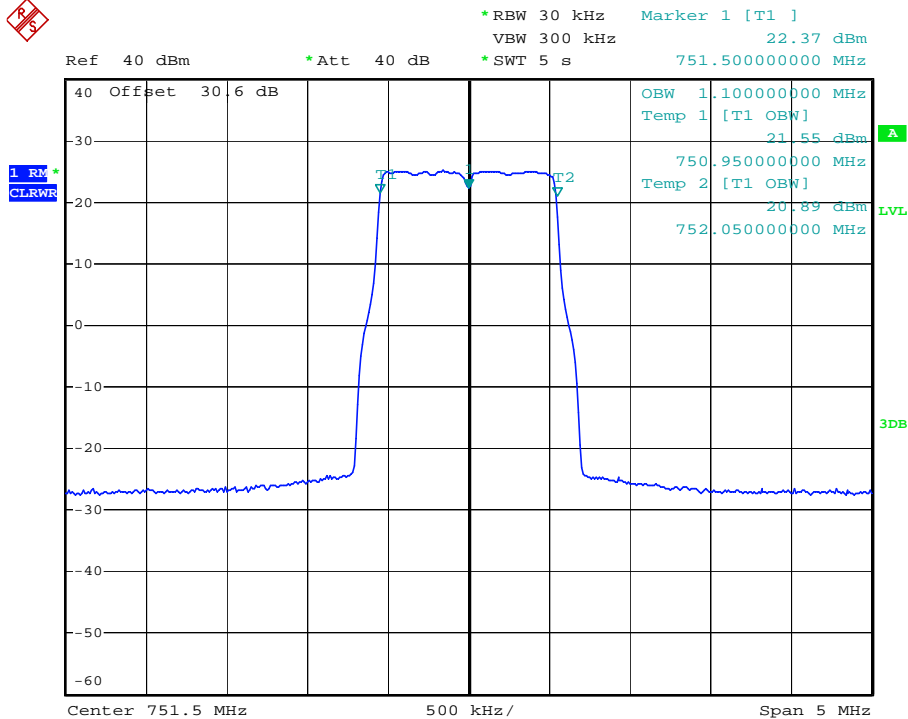

plot 6.3.1.2-#1 Occupied Bandwidth: §90.210, §2.1049; RSS-GEN; Test results; Downlink; LTE 746 – 757MHz MAIN Output

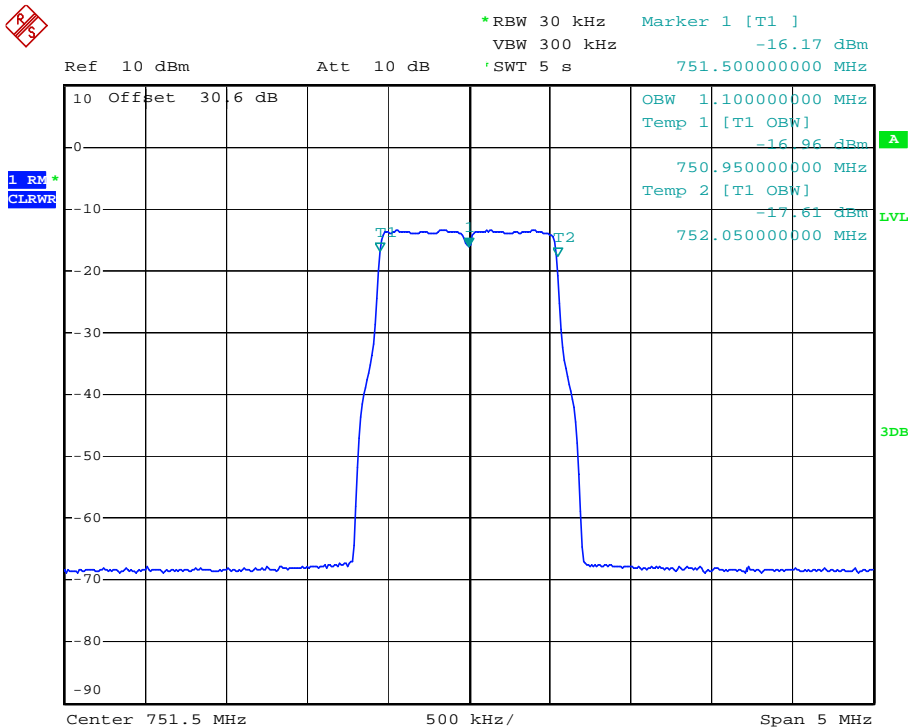

plot 6.3.1.2-#2 Occupied Bandwidth: §90.210, §2.1049; RSS-GEN; Test results; Downlink; LTE 746 – 757MHz MAIN Input



6.3.1.3 LTE 728 – 746MHz MIMO

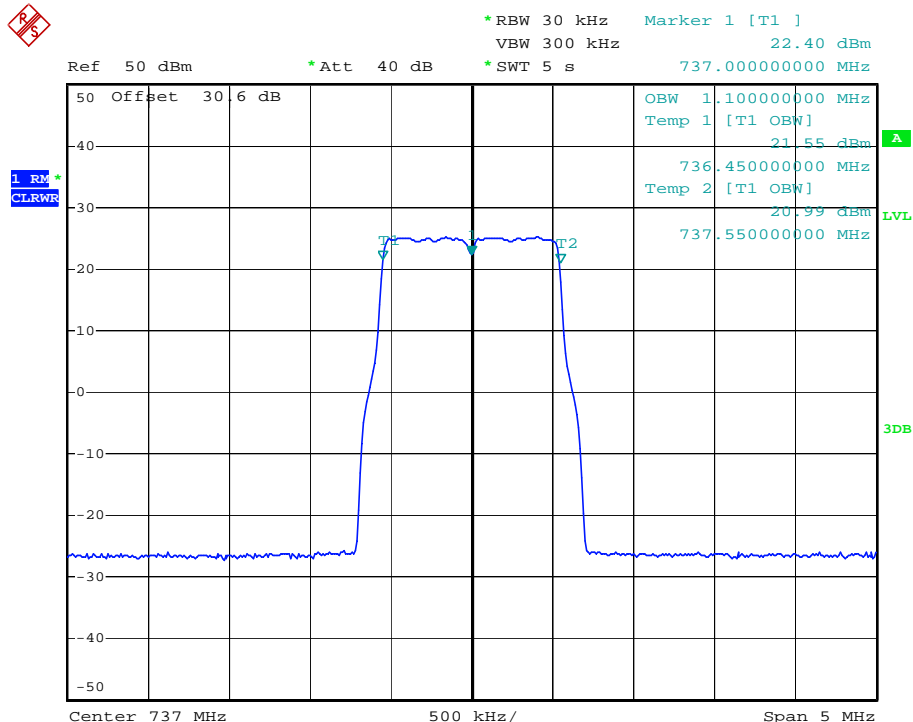

plot 6.3.1.3-#1 Occupied Bandwidth: §90.210, §2.1049; RSS-GEN; Test results; Downlink; LTE 728 – 746MHz MIMO Output

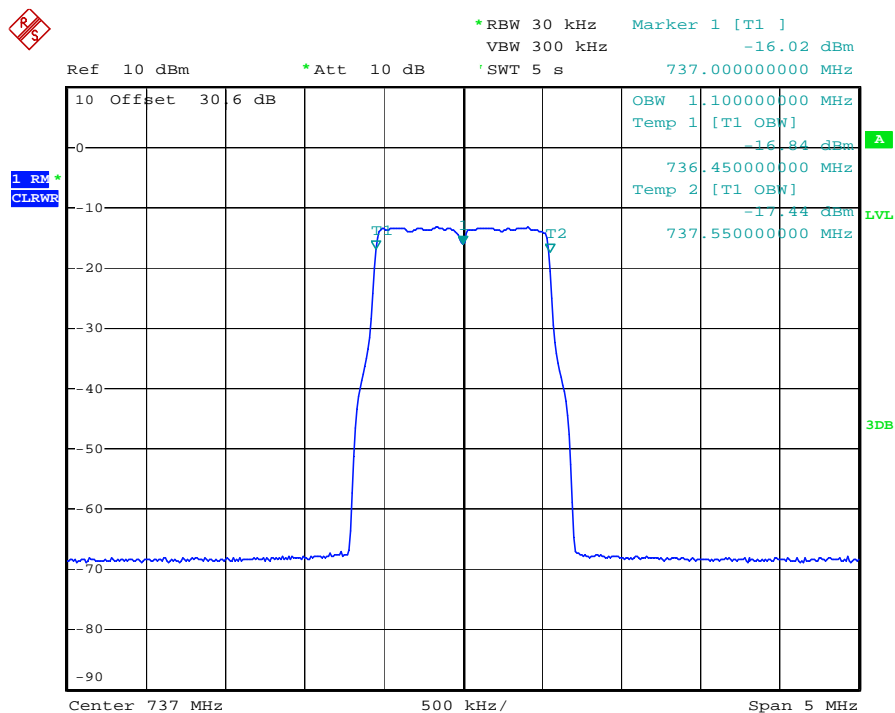

plot 6.3.1.3-#2 Occupied Bandwidth: §90.210, §2.1049; RSS-GEN; Test results; Downlink; LTE 728 – 746MHz MIMO Input



6.3.1.4 LTE 746 – 757MHz MIMO

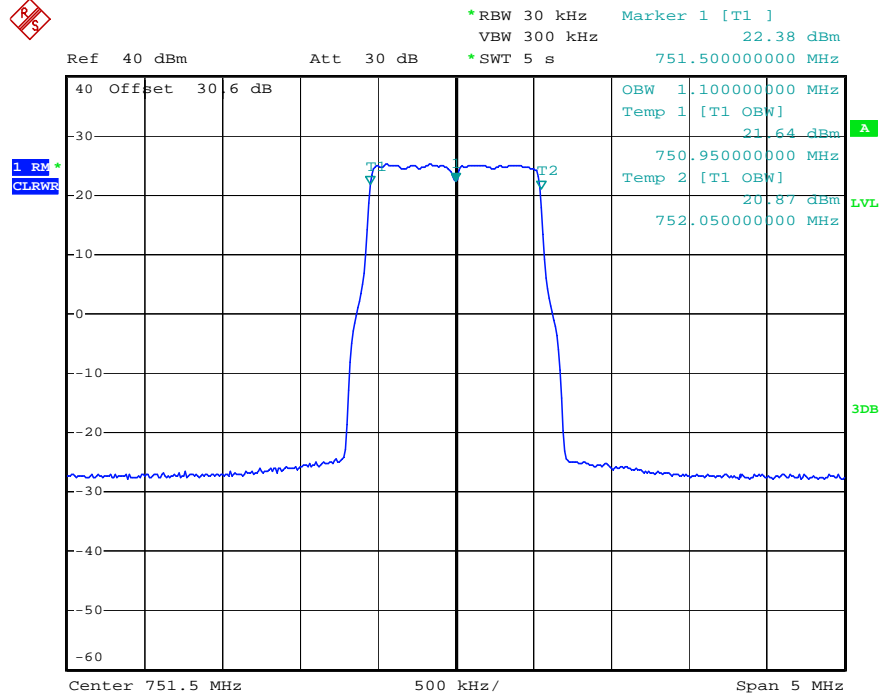

plot 6.3.1.4-#1 Occupied Bandwidth: §90.210, §2.1049; RSS-GEN; Test results; Downlink; LTE 746 – 757MHz MIMO Output

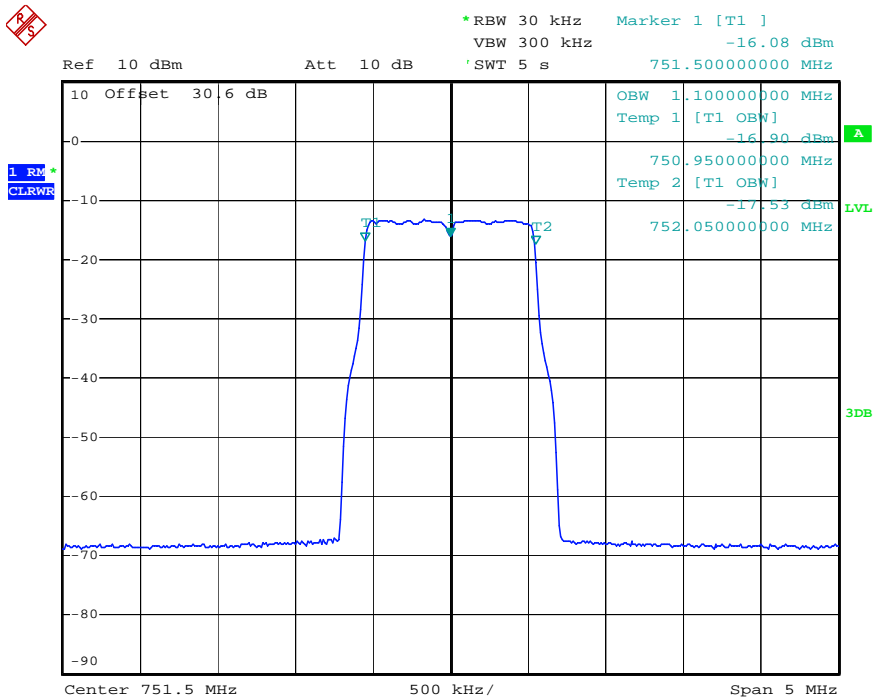

plot 6.3.1.4-#2 Occupied Bandwidth: §90.210, §2.1049; RSS-GEN; Test results; Downlink; LTE 746 – 757MHz MIMO Input

Test Report No.: 11-013

FCC ID: XS5- ION-M77PMU

IC ID: 2237E-IONM77PMU



Uplink

n.a.

Note: The EUT does not transmit over the air in the uplink direction.

6.4 Summary test result

Test result	complies, according the plots above
Tested by:	L.Oskerko
Date:	13.12.2010



7 Spurious Emissions at Antenna Terminals: §27.53, §2.1051; RSS-131, RSS-GEN

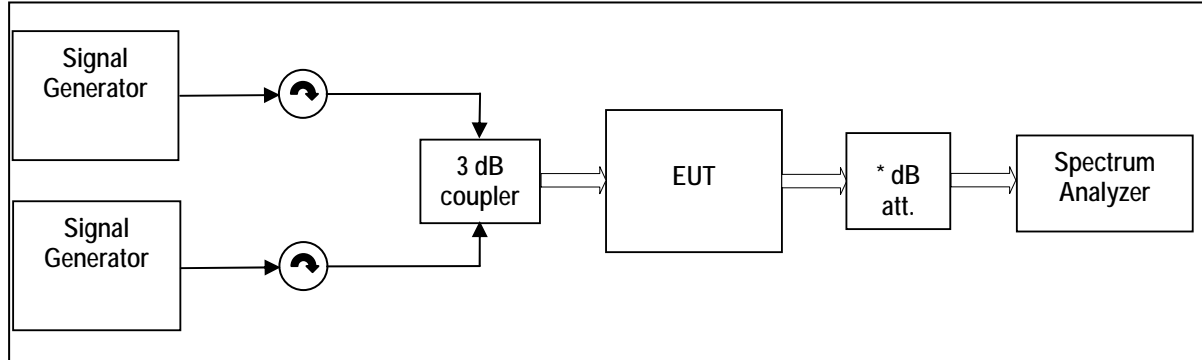

figure 7-#1 Test setup: Spurious Emissions at Antenna Terminals: §27.53, §2.1051; RSS-131, RSS-GEN

Measurement uncertainty	± 0,54 dB ± 1,2 dB ± 1,5 dB	9 kHz to 3 GHz 3 GHz to 7 GHz 7 GHz to 26 GHz
Test equipment used	8372, 8961, 8849, 7192, 7287, 7288, 7391	

7.1 Limit

Minimum standard:

Para. No.27.53 (c) and (g)

(c) For operations in the 746–758 MHz band and the 776–788 MHz band, the power of any emission outside the licensee's frequency band(s) of operation shall be attenuated below the transmitter power (P) within the licensed band(s) of operation, measured in watts, in accordance with the following:

(1) On any frequency outside the 746–758 MHz band, the power of any emission shall be attenuated outside the band below the transmitter power (P) by at least $43 + 10 \log (P)$ dB;

(3) On all frequencies between 763–775 MHz and 793–805 MHz, by a factor not less than $76 + 10 \log (P)$ dB in a 6.25 kHz band segment, for base and fixed stations;

(g) For operations in the 698–746 MHz band, the power of any emission outside a licensee's frequency band(s) of operation shall be attenuated below the transmitter power (P) within the licensed band(s) of operation, measured in watts, by at least $43 + 10 \log (P)$ dB. Compliance with this provision is based on the use of measurement instrumentation employing a resolution bandwidth of 100 kilohertz or greater. However, in the 100 kilohertz bands immediately outside and adjacent to a licensee's frequency block, a resolution bandwidth of at least 30 kHz may be employed

7.2 Test method

Para. No 2.1051 Measurements required: Spurious emissions at antenna terminals.

The radio frequency voltage or powers generated within the equipment and appearing on a spurious frequency shall be checked at the equipment output terminals when properly loaded with a suitable artificial antenna. Curves or equivalent data shall show the magnitude of each harmonic and other spurious emission that can be detected when the equipment is operated under the conditions specified in § 2.1049 as appropriate. The magnitude of spurious emissions which are attenuated more than 20 dB below the permissible value need not be specified.

[39 FR 5919, Feb. 15, 1974. Redesignated and amended at 63 FR 36599, July 7, 1998]



7.3 Test results

7.3.1 Downlink

<1MHz from Band Edge

Detector: RMS.

Modulation	Measured at Band Edge	Carriers		RBW VBW Span	Max. level (dBm)	Plot #
LTE	Lower Edge	728,7 MHz 730,1 MHz	MAIN	30kHz 300kHz 6MHz	-15,7	7.3.1.1-#1
	Upper Edge	743,9 MHz 745,3 MHz				7.3.1.1-#2
LTE	Lower Edge	746,7 MHz 748,1 MHz		30kHz 300kHz 6MHz	-15,2	7.3.1.2-#1
	Upper Edge	754,9 MHz 756,3 MHz				7.3.1.2-#2
LTE	Lower Edge	728,7 MHz 730,1 MHz	MIMO	30kHz 300kHz 6MHz	-17,4	7.3.1.3-#1
	Upper Edge	743,9 MHz 745,3 MHz				7.3.1.3-#2
LTE	Lower Edge	746,7 MHz 748,1 MHz		30kHz 300kHz 6MHz	-15,2	7.3.1.4-#1
	Upper Edge	754,9 MHz 756,3 MHz				7.3.1.4-#2

table 7.3-#1 Spurious Emissions at Antenna Terminals: §27.53, §2.1051; RSS-131, RSS-GEN Test results <1MHz from Band



>1MHz from Band Edge

Detector: RMS.

Modulation	Carrier		RBW VBW Span	Max. level (dBm)	Plot -
LTE	737 MHz	MAIN	1MHz 3MHz 30MHz – 8GHz	-27	7.3.1.5 #1
LTE	751,5 MHz		1MHz 3MHz 30MHz – 8GHz	-27	7.3.1.6 #1
LTE	737 MHz	MIMO	1MHz 3MHz 30MHz – 8GHz	-26,77	7.3.1.7 #1
LTE	751,5 MHz		1MHz 3MHz 30MHz – 8GHz	-26,89	7.3.1.8 #1

table 7.3-#2 Spurious Emissions at Antenna Terminals: §27.53, §2.1051; RSS-131, RSS-GEN Test results >1MHz from Band Edge

Calculation of the limit according to §27.53 (c)(3) On all frequencies between 763–775 MHz and 793–805 MHz, by a factor not less than $76 + 10 \log (P)$ dB in a 6.25 kHz band segment:

$P_{out} = 43\text{dBm} = 20\text{W}$.

$76 + 10 \cdot \log(20\text{W}/1\text{W}) \text{ dB} = 89 \text{ dB Attenuation} \Rightarrow 43\text{dBm} - 89\text{dB} = -46 \text{ dBm}$ in a 6.25 kHz band segment
Spurious measured in the plot with a RBW of 1MHz so the limit is calculated:

$\Rightarrow -46\text{dBm} / 6,25\text{kHz} + 10 \cdot \log(1\text{MHz}/6,25\text{kHz}) = -23,96\text{dBm} / 1\text{MHz}$
maximum measured emission level is $-26,77\text{dBm} / 1\text{MHz}$: passed.



7.3.1.1 LTE < 1MHz to band edge 728 – 746MHz, MAIN

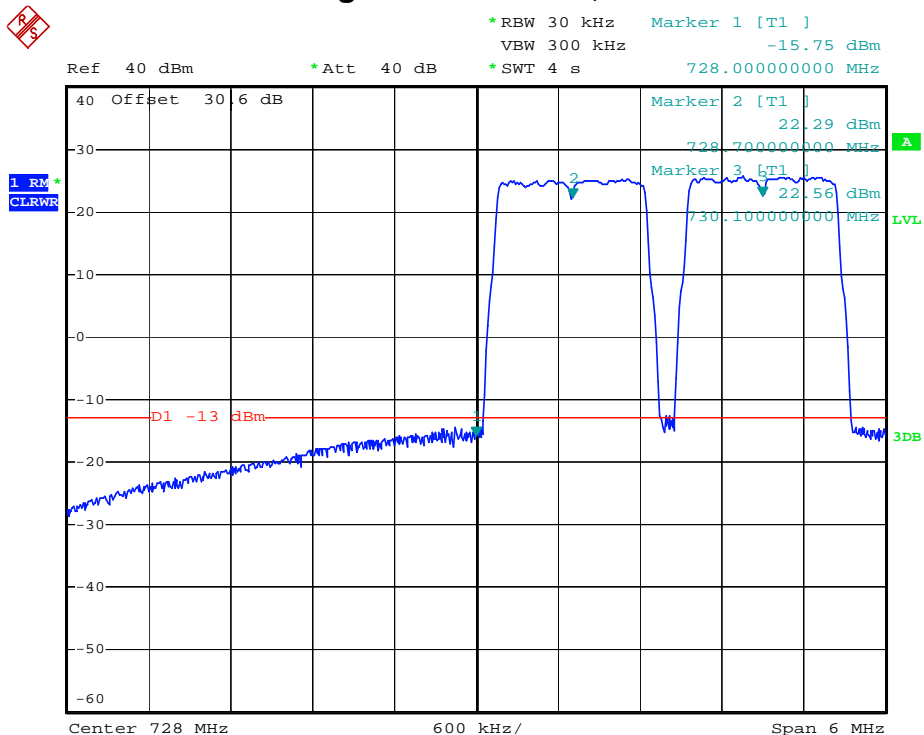

plot 7.3.1.1-#1 Spurious Emissions at Antenna Terminals: §27.53, §2.1051; RSS-131, RSS-GEN; Test results; Downlink; LTE < 1MHz to band edge 728 – 746MHz, MAIN Lower Band Edge

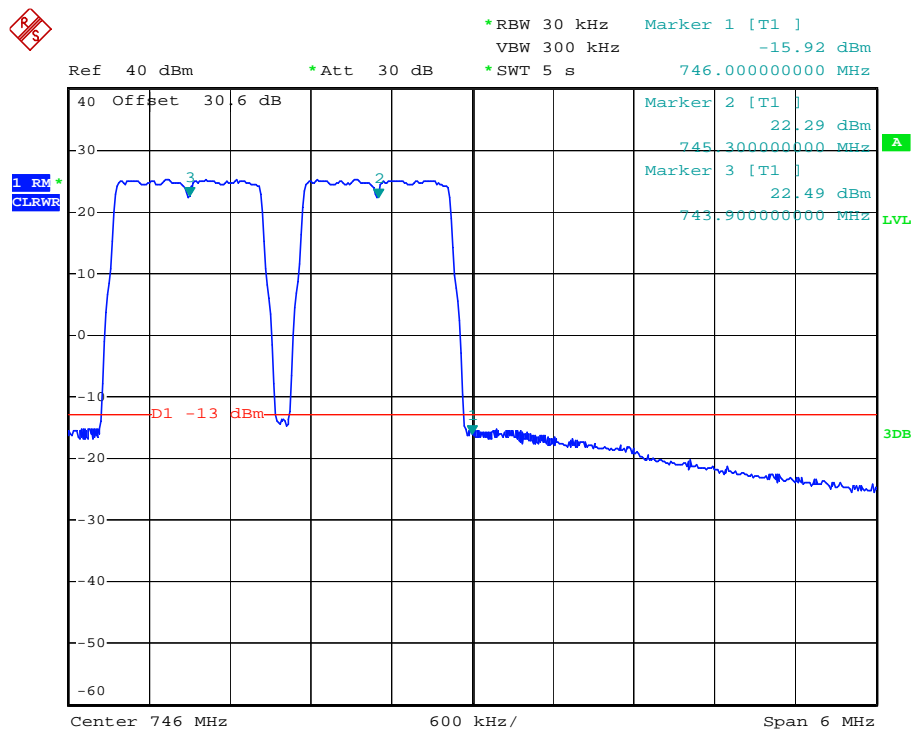

plot 7.3.1.1-#2 Spurious Emissions at Antenna Terminals: §27.53, §2.1051; RSS-131, RSS-GEN; Test results; Downlink; LTE < 1MHz to band edge 728 – 746MHz, MAIN Upper Band Edge



7.3.1.2 LTE < 1MHz to band edge 746 – 757MHz, MAIN

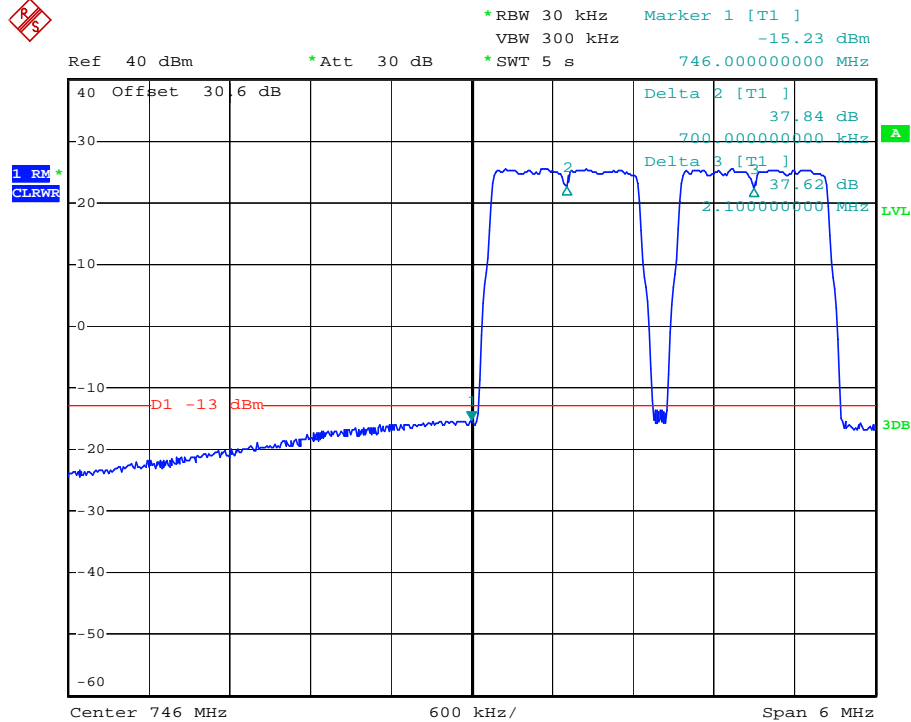

plot 7.3.1.2-#1 Spurious Emissions at Antenna Terminals: §27.53, §2.1051; RSS-131, RSS-GEN; Test results; Downlink; LTE < 1MHz to band edge 746 – 757MHz, MAIN Lower Band Edge

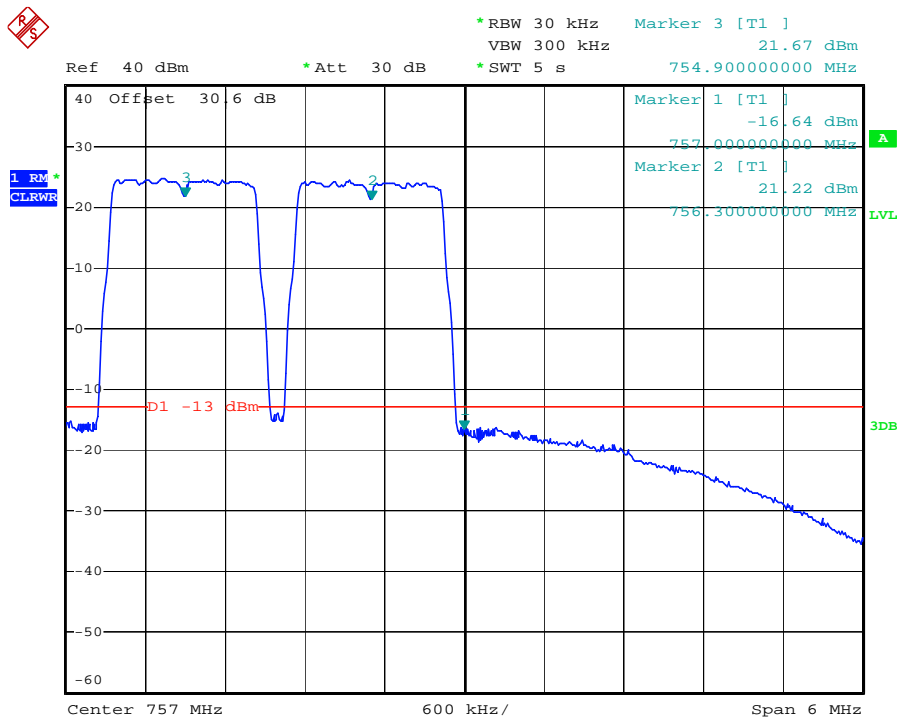

plot 7.3.1.2-#2 Spurious Emissions at Antenna Terminals: §27.53, §2.1051; RSS-131, RSS-GEN; Test results; Downlink; LTE < 1MHz to band edge 746 – 757MHz, MAIN Upper Band Edge



7.3.1.3 LTE < 1MHz to band edge 728 – 746MHz, MIMO

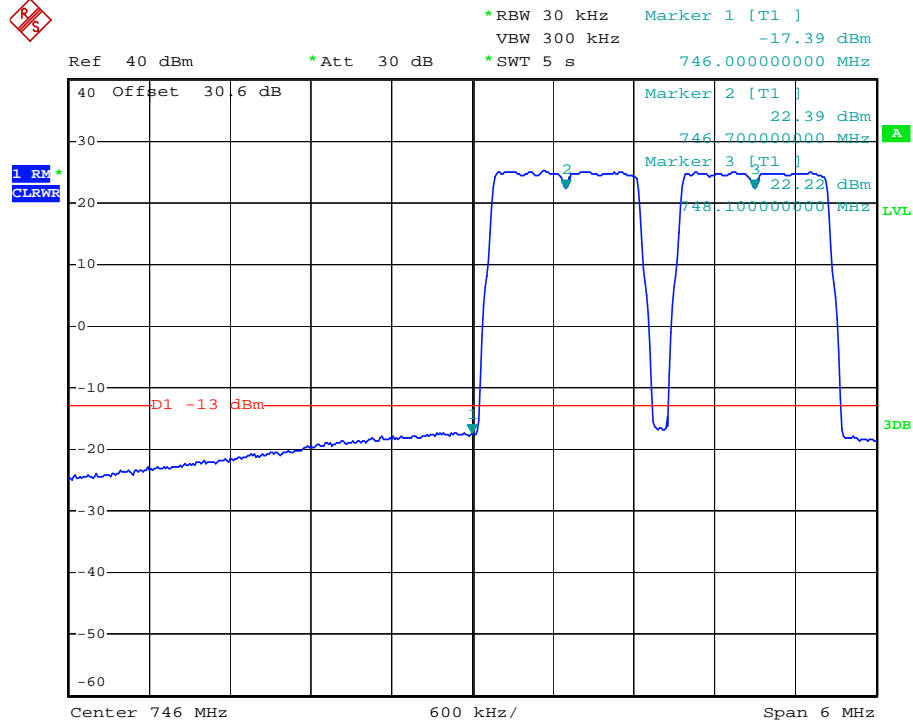

plot 7.3.1.3-#1 Spurious Emissions at Antenna Terminals: §27.53, §2.1051; RSS-131, RSS-GEN; Test results; Downlink; LTE < 1MHz to band edge 728 – 746MHz, MIMO Lower Band Edge

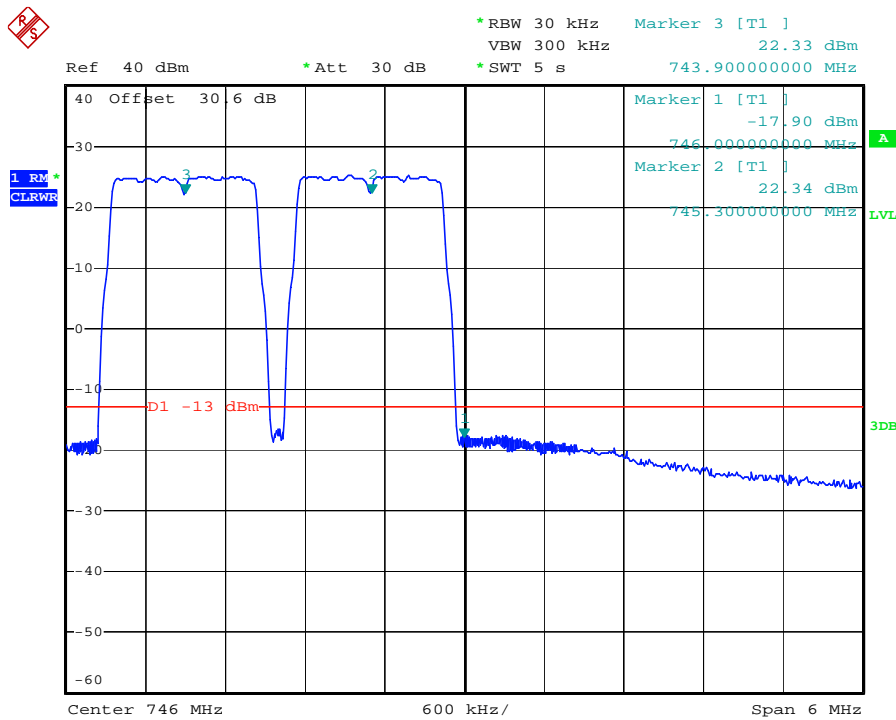

plot 7.3.1.3-#2 Spurious Emissions at Antenna Terminals: §27.53, §2.1051; RSS-131, RSS-GEN; Test results; Downlink; LTE < 1MHz to band edge 728 – 746MHz, MIMO Upper Band Edge



7.3.1.4 LTE < 1MHz to band edge 746 – 757MHz, MIMO

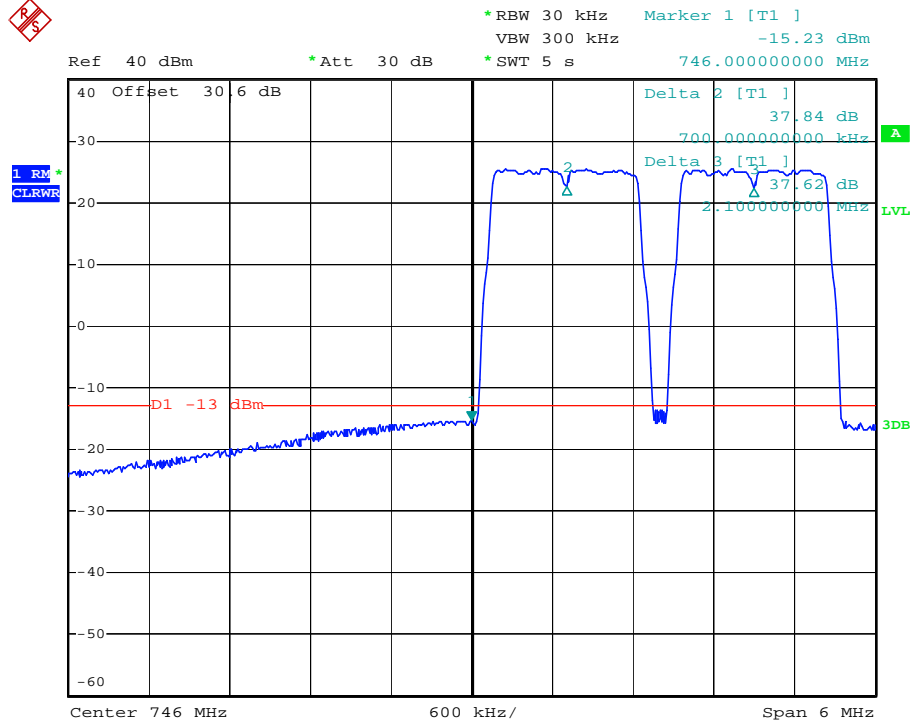

plot 7.3.1.4-#1 Spurious Emissions at Antenna Terminals: §27.53, §2.1051; RSS-131, RSS-GEN; Test results; Downlink; LTE < 1MHz to band edge 746 – 757MHz, MIMO Lower Band Edge

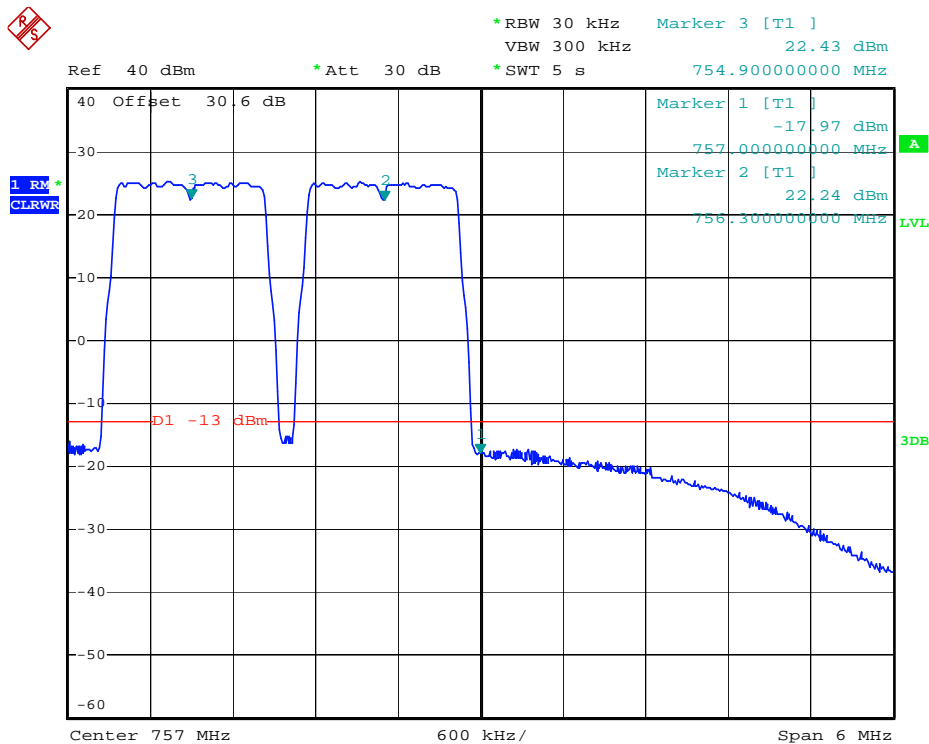

plot 7.3.1.4-#2 Spurious Emissions at Antenna Terminals: §27.53, §2.1051; RSS-131, RSS-GEN; Test results; Downlink; LTE < 1MHz to band edge 746 – 757MHz, MIMO Upper Band Edge



7.3.1.5 LTE > 1MHz to band edge 728 – 746MHz, MAIN

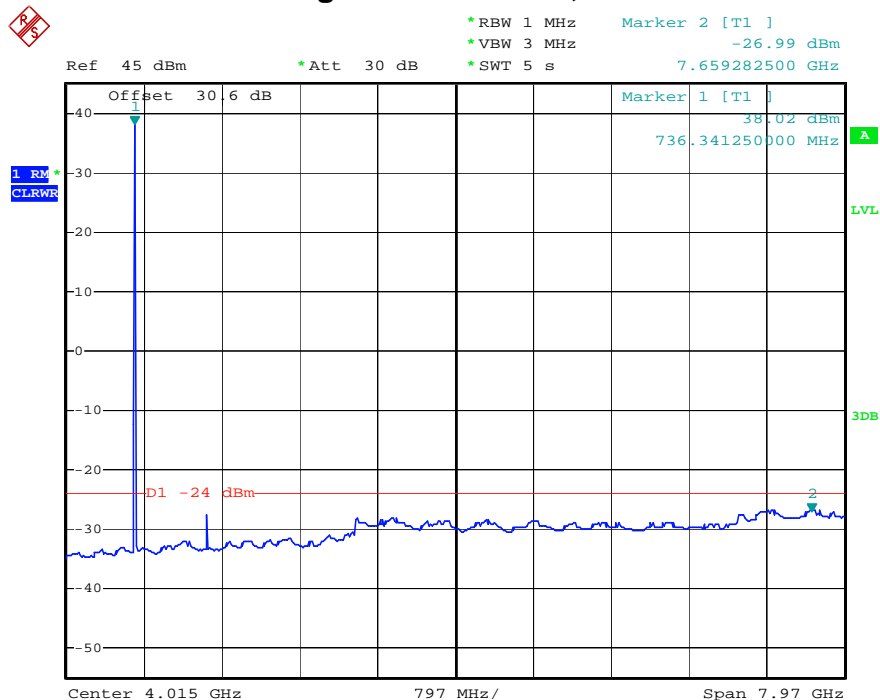

plot 7.3.1.5-#1 Spurious Emissions at Antenna Terminals: §27.53, §2.1051; RSS-131, RSS-GEN; Test results; Downlink; LTE > 1MHz to band edge 728 – 746MHz, MAIN;

7.3.1.6 LTE > 1MHz to band edge 746 – 757MHz, MAIN

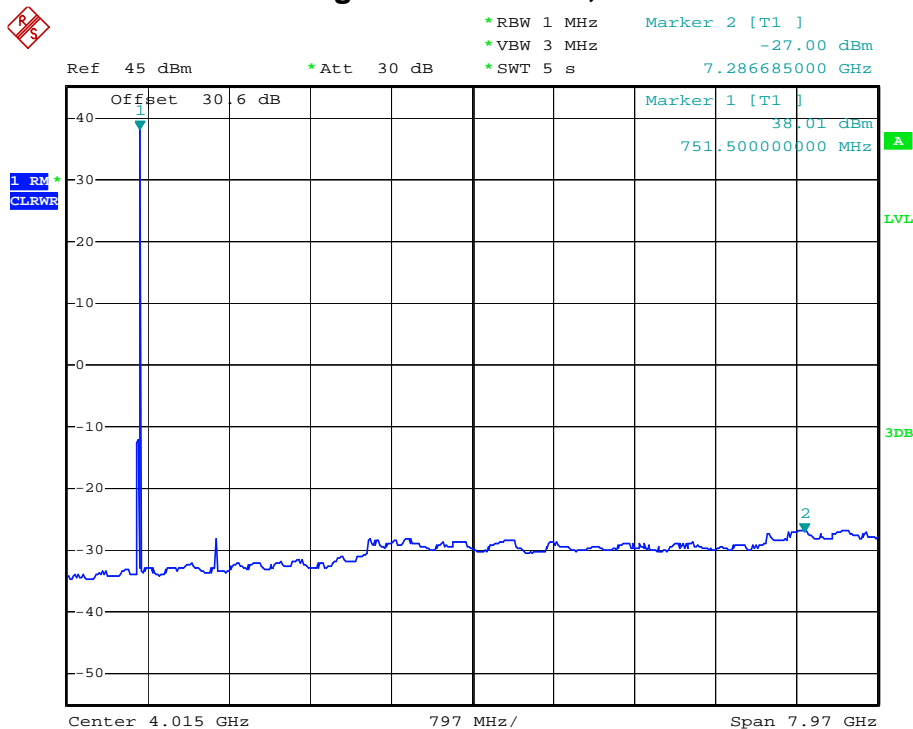

plot 7.3.1.6-#1 Spurious Emissions at Antenna Terminals: §27.53, §2.1051; RSS-131, RSS-GEN; Test results; Downlink; LTE > 1MHz to band edge 746 – 757MHz, MAIN;



7.3.1.7 LTE > 1MHz to band edge 728 – 746MHz, MIMO

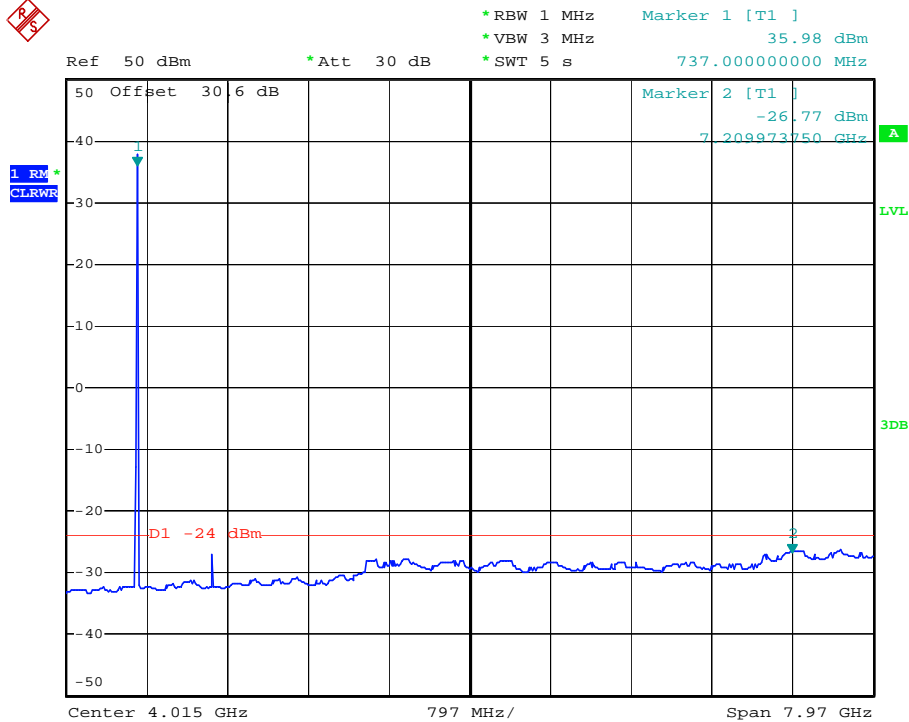

plot 7.3.1.7-#1 Spurious Emissions at Antenna Terminals: §27.53, §2.1051; RSS-131, RSS-GEN; Test results; Downlink; LTE > 1MHz to band edge 728 – 746MHz, MIMO;

7.3.1.8 LTE > 1MHz to band edge 746 – 757MHz, MIMO

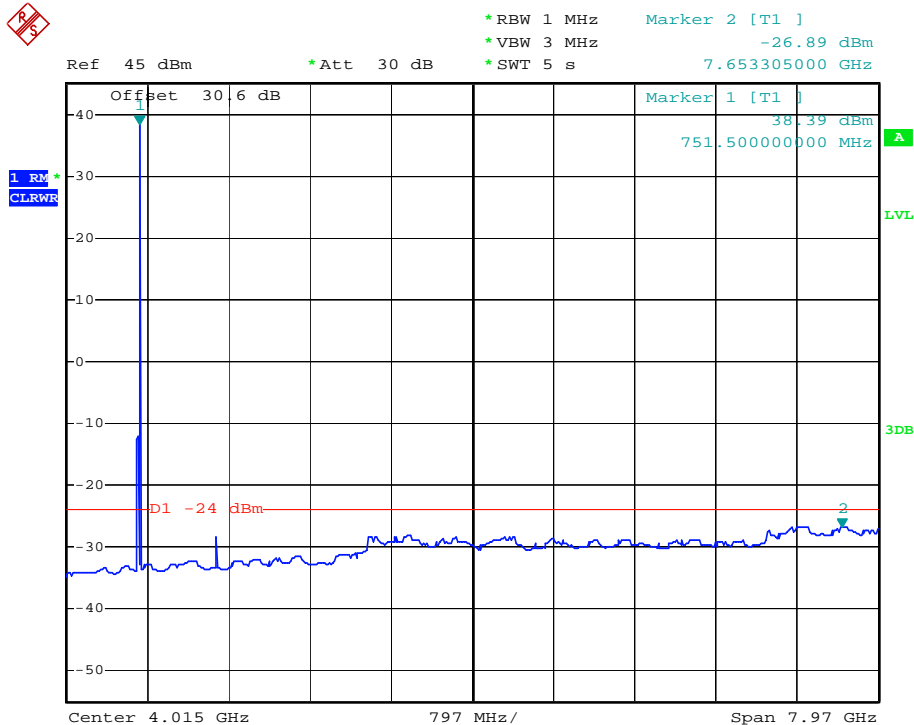

plot 7.3.1.8-#1 Spurious Emissions at Antenna Terminals: §27.53, §2.1051; RSS-131, RSS-GEN; Test results; Downlink; LTE > 1MHz to band edge 746 – 757MHz, MIMO;

Test Report No.: 11-013

FCC ID: XS5- ION-M77PMU

IC ID: 2237E-IONM77PMU



7.3.2 Uplink

n.a.

Note: The EUT does not transmit over the air in the uplink direction.

7.4 Summary test result

Test result	complies, according the plots above
Tested by:	L.Oskerko
Date:	13.12.2010

8 Radiated Spurious Emissions at the ECL (TEMPTON): §27.53, §2.1053, RSS-Gen, RSS-131



picture 8.1: label



picture 8.2: ION-M7P/7P



picture 8.3: Test setup: Field Strength Emission <1 GHz @3m in the FAC

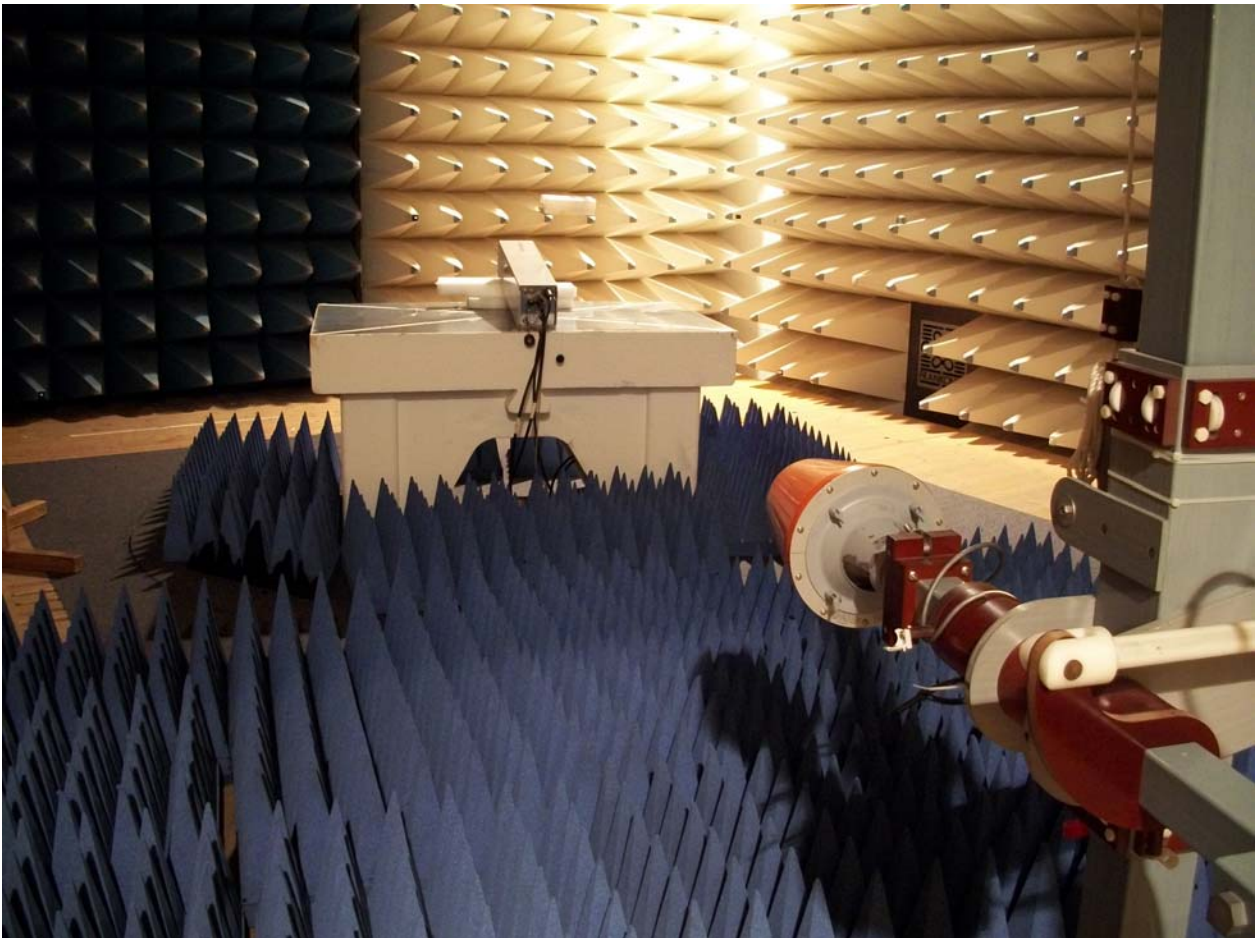

picture 8.4: Test setup: Field Strength Emission >1 GHz @3m in the FAC

Test Report No.: 11-013

FCC ID: XS5- ION-M77PMU

IC ID: 2237E-IONM77PMU



This clause specifies requirements for the measurement of radiated emission.

Frequency range	Distance: EUT <-> antenna / location	Limit	Test method
30 MHz – 8 GHz	3 metres / FAC	FCC 47 CFR Part 27.53	TIA/EIA-603-C:2004
		IC RSS-131 sec. 4.4	

Test equipment used:

Designation	Type	Manufacturer	Invent.-no.	Cal.-date	due Cal.- date	used
EMI test receiver	ESI40	Rohde & Schwarz	E1687	21.12.2010	21.12.2011	X
Antenna	CBL 6111	Chase	K1149	24.09.2010	24.09.2011	X
RF Cable		Frankonia	K1121 SET	01.07.2010	01.07.2011	X
Antenna	HL 025	R&S	K809	04.02.2010	04.02.2011	X
Preamplifier	AFS4-00102000	Miteq	K838	06.10.2009	06.10.2012	X
RF Cable	Sucoflex 100	Suhner	K1742	09.04.2010	09.04.2011	X

The REMI version 2.135 has been used to maximize radiated emission from the EUT with regards to ANSI C63.4:2009.

Test set-up:

Test location: FAC
Both, the Fully Anechoic Chamber (FAC) and the Semi Anechoic Chamber (SAC) fulfil the requirements of ANSI C63.4 and CISPR 16-1-4 with regards to NSA and SVSWR.

Test Voltage: 230V / 50 Hz
Type of EUT: Wall mounted

Measurement uncertainty:

Measurement uncertainty expanded (95% or K=2)	± 4,7 dB for ANSI C63.4 measurement ± 0,5 dB for TIA-603 measurement
--	---

8.1 Method of Measurement

Measurement procedure. TIA-603-C

The antenna substitution method is used to determine the equivalent radiated power at spurious frequencies. The spurious emissions are measured at a distance of 3 meters. The EUT is then replaced with a reference substitution antenna with a known gain referenced to a dipole. This antenna is fed with a signal at the spurious frequency. The level of the signal is adjusted to repeat the previously measured level. The resulting eirp is the signal level fed to the reference antenna corrected for gain referenced to an isotropic dipole (see Figure 7.2).

From KDB (AMPLIFIER, BOOSTER, AND REPEATER REMINDER SHEET):

Radiated spurs (enclosure) – Use of CW signal (low, mid, and high freq.) is acceptable rather than all modulations.

The Bottom/Middle/Top frequencies for Part 27 F/H are as follows:

- 728/737/746 MHz (§27 Subpart H)
- 746/755/763 MHz (§27 Subpart F)

The maximum RFI field strength was determined during the measurement by rotating the turntable (± 180 degrees) as like defined in ANSI C63.4. A measurement receiver has been used with a RBW 120 kHz up to 1 GHz and 1 MHz above 1 GHz. Steps width during the measurement was half the RBW.

Both, the Fully Anechoic Chamber (FAC) and the Semi Anechoic Chamber (SAC) fulfil the requirements of ANSI C63.4 and CISPR 16-1-4 with regards to NSA and SVSWR.

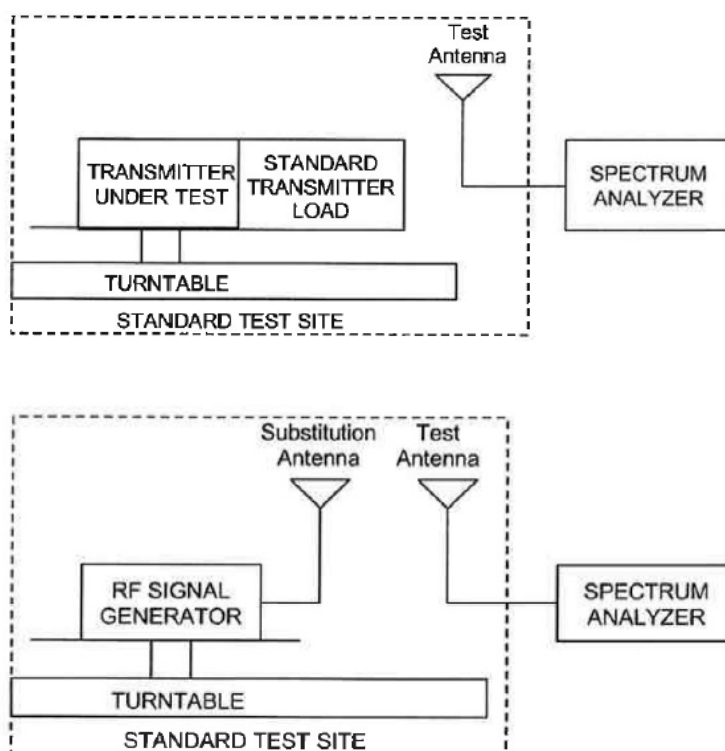

Figure #8.3 Substitution methods TIA/EIA-603-C



8.2 Limit

§27.53 Emission limitations / RSS-GEN sec. 4.9; RSS-131 sec. 4.4

Minimum standard:

Para. No.27.53 (c/d/g)

(c) For operations in the 746–758 MHz band and the 776–788 MHz band, the power of any emission outside the licensee's frequency band(s) of operation shall be attenuated below the transmitter power (P) within the licensed band(s) of operation, measured in watts, in accordance with the following:

(1) On any frequency outside the 746–758 MHz band, the power of any emission shall be attenuated outside the band below the transmitter power (P) by at least $43 + 10 \log (P)$ dB.

(g) For operations in the 698–746 MHz band, the power of any emission outside a licensee's frequency band(s) of operation shall be attenuated below the transmitter power (P) within the licensed band(s) of operation, measured in watts, by at least $43 + 10 \log (P)$ dB. Compliance with this provision is based on the use of measurement instrumentation employing a resolution bandwidth of 100 kilohertz or greater. However, in the 100 kilohertz bands immediately outside and adjacent to a licensee's frequency block, a resolution bandwidth of at least 30 kHz may be employed

The Emission limit is **-13dBm**.

(d) For operations in the 758–763 MHz and 788–793 MHz bands, the power of any emission outside the licensee's frequency bands of operation shall be attenuated below the transmitter power (P) within the licensed band(s) of operation, measured in watts, in accordance with the following:

(1) On all frequencies between 769–775 MHz and 799–805 MHz, by a factor not less than $76 + 10 \log (P)$ dB in a 6.25 kHz band segment, for base and fixed stations;

The Emission limit is:

- **-33dBm** for measurements up to 1GHz
- **-24dBm** for measurements above 1 GHz

These Values have been calculated by a formula, which was a result of an inquiry (No. 141765) of the KDB:

$$\text{Limit} = P_{OUT} - (76 + 10\text{LOG}(P_{OUT}) - 10\text{LOG}(Bwidth / 6.25\text{kHz}))$$

8.3 Receiver Settings

	up to 1 GHz	above 1 GHz
Measurement bandwidth	120 kHz	1 MHz
Step width	60 kHz	500 kHz
Dwell time	20ms	
Detector	Peak	Average

8.4 Climatic values in the lab

Temperature	18,5°C
Relative Humidity	45%
Air-pressure	1014 hPa



8.5 Test results

8.5.1 30 MHz to 1 GHz Downlink (Bottom – Middle – Top) Subpart H

Bottom: 728MHz; Middle: 737MHz; Top: 746MHz

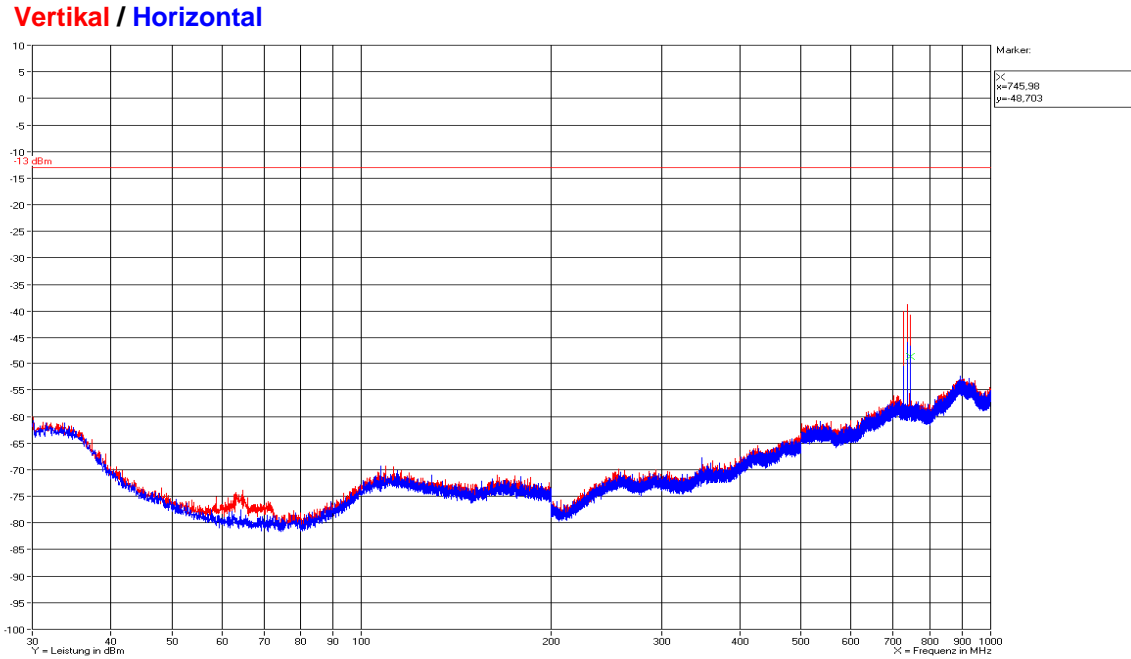

8.5.2 30 MHz to 1 GHz Downlink (Bottom – Middle – Top) Subpart F

Bottom: 746MHz; Middle: 751,5MHz; Top: 757MHz

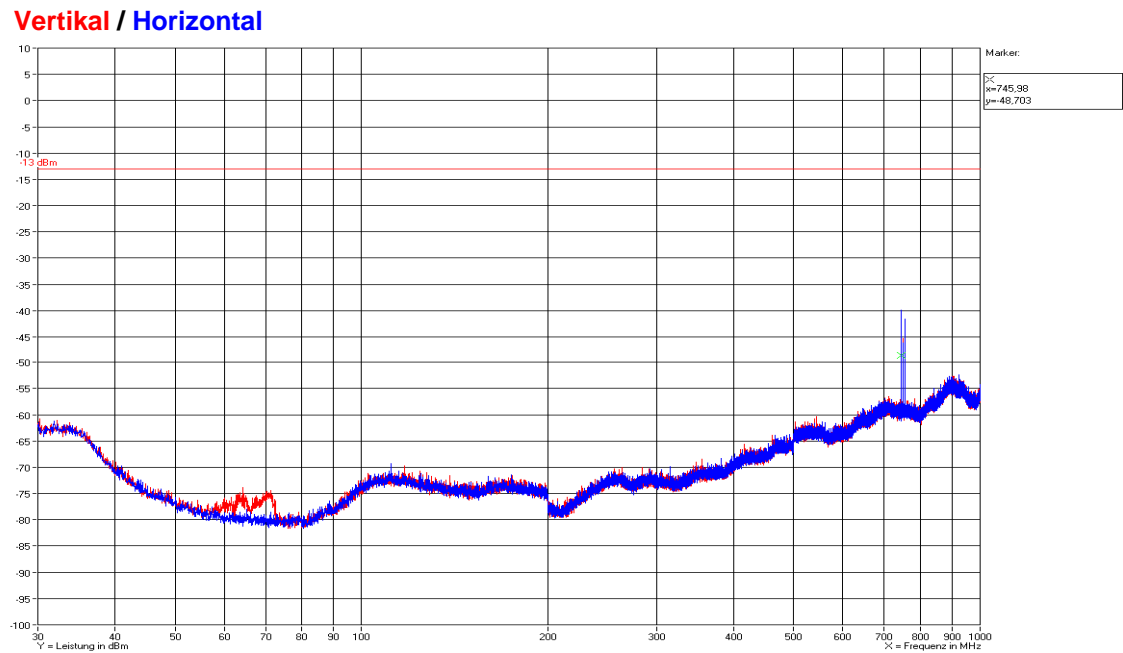



8.5.2.1 1 GHz to 8 GHz Downlink (Bottom – Middle – Top) Subpart H

Bottom: 728MHz; Middle: 737MHz; Top: 746MHz

Vertikal / Horizontal

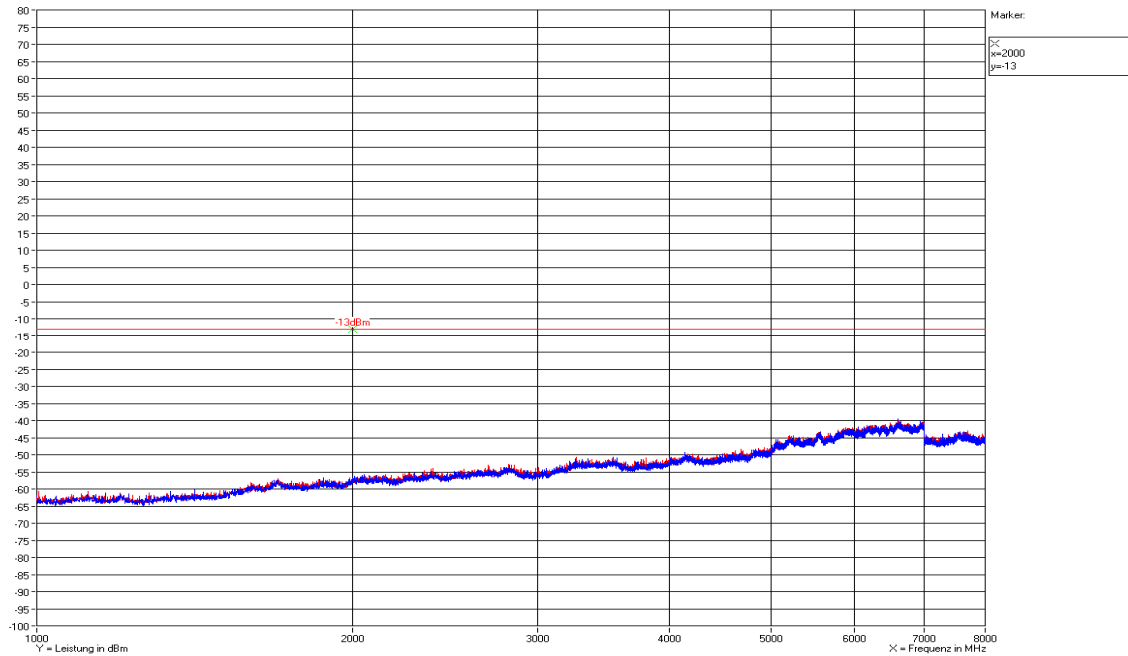

8.5.2.2 1 GHz to 8 GHz Downlink (Bottom – Middle – Top) Subpart F

Bottom: 746MHz; Middle: 751,5MHz; Top: 757MHz

Vertikal / Horizontal

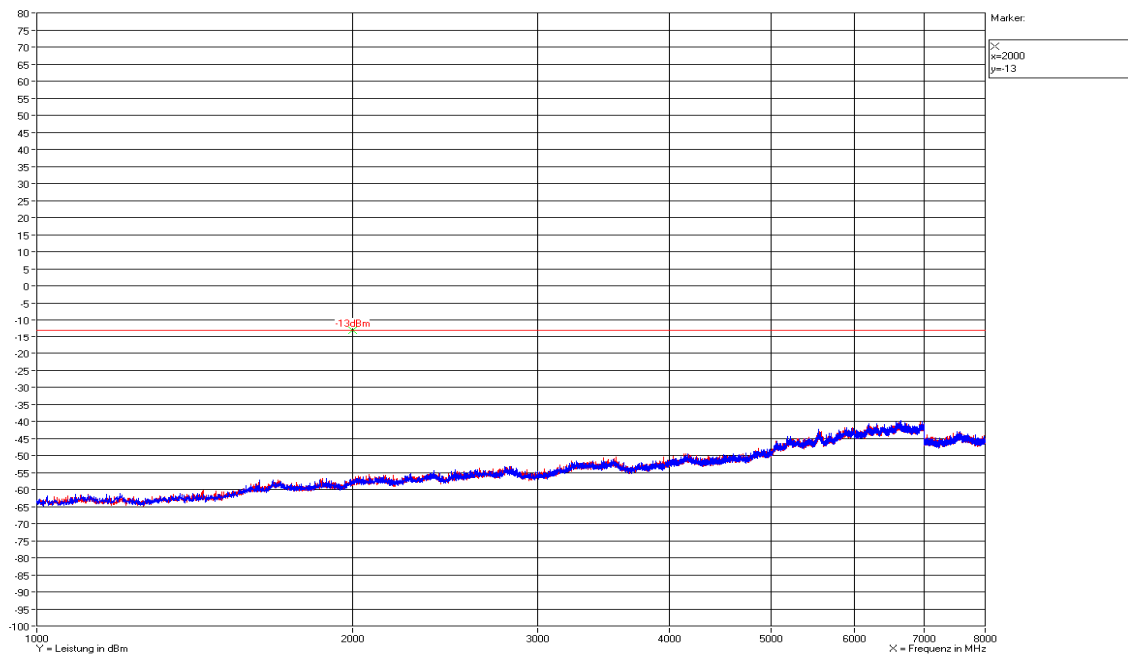

Zahlmann / 24.01.2011



The radiated spurious emission measurements have been passed!

9 History

Revision	Modification	Date	Name
01.00	Initial report	24.01.2011	Zahlmann
02.00	FCC and IC-ID rectified	02.02.2011	Zahlmann

******* End of test report *******