



ECL-TA Test Report No.: 20-006

Designation:	CAP MX AC 6/7E/80-85/17E/19/23/25T
Manufacturer:	Andrew
Serial No(s):	8
ID No.	7830127-0001, Rev.: 00
Test Specification(s):	ANSI 63.26:2015 FCC Rules and Regulations as listed in 47 CFR, Part 20:2019-10-01 FCC Rules and Regulations as listed in 47 CFR, Part 90.219:2019-10-01
Test Plan:	Measurement of Band 27/CELL 800, downlink.
Test Result:	Passed

Date of issue:	2020-10-23		Signature:
Version:	01	Technical Reviewer:	
Date of delivery:	2020-07		
Performance date:	2020-07-07. – 2020-09-09	Report Reviewer:	



The test results relates only to the tested item. The sample has been provided by the client.
Without the written consent of Bureau Veritas Consumer Products Services Germany GmbH excerpts of this report shall not be reproduced.

Bureau Veritas
Consumer Products Services Germany GmbH
www.bureauveritas.de/cps
Phone: +49 (0)40 – 740 41 – 0

Schwerin
Wilhelm-Hennemann-Str. 8, 19061 Schwerin
cps-schwerin@de.bureauveritas.com

Tuerkheim
Businesspark A96, 86842 Tuerkheim
cps-tuerkheim@de.bureauveritas.com

Managing Director: Sebastian Doose
Reg.No.: Schwerin HRB 3564

Hamburg
Oehleckerring 40, 22419 Hamburg
cps-hamburg@de.bureauveritas.com

Nuremberg
Thurn-und-Taxis-Str. 18, 90411 Nuremberg
cps-nuernberg@de.bureauveritas.com



**BUREAU
VERITAS**

ECL-TA-20-006-V01.00

TA tests on Andrew CAP MX AC 6/7E/80-
85/17E/19/23/25T

Commscope

Client:

Andrew Wireless System GmbH

Industriering 10

86675 Buchdorf Germany

Test Laboratory:

Bureau Veritas Consumer Products Services Germany GmbH

Thurn-und-Taxis-Straße 18

D-90411 Nürnberg

Tel.: +49 40 74041 0

Fax: +49 40 74041-2755

Versions management:

V01.00

Initial release



ECL-TA-20-006-V01.00

TA tests on Andrew CAP MX AC 6/7E/80-
85/17E/19/23/25T

Table of Contents

1	APPLIED STANDARDS AND TEST SUMMARY	4
1.1	APPLIED STANDARDS	4
1.2	FCC-IC CORRELATION TABLE	5
1.3	MEASUREMENT SUMMARY/SIGNATURES	6
2	ADMINISTRATIVE DATA	9
2.1	TESTING LABORATORY	9
2.2	APPLICANT DATA	9
2.3	MANUFACTURER DATA	9
3	TEST OBJECT DATA.....	10
3.1	GENERAL EUT DESCRIPTION	10
3.2	EUT MAIN COMPONENTS	11
3.3	ANCILLARY EQUIPMENT	11
3.4	AUXILIARY EQUIPMENT.....	12
3.5	EUT SETUPS.....	13
3.6	PRODUCT LABELLING.....	14
4	TEST RESULTS	15
4.1	EFFECTIVE RADIATED POWER, MEAN OUTPUT POWER AND ZONE ENHANCER GAIN 15	
4.2	PEAK TO AVERAGE RATIO	21
4.3	OCCUPIED BANDWIDTH/INPUT-VERSUS-OUTPUT SPECTRUM.....	25
4.4	CONDUCTED SPURIOUS EMISSIONS AT ANTENNA TERMINALS.....	33
4.5	OUT-OF-BAND EMISSION LIMITS	42
4.6	OUT-OF-BAND REJECTION	53
4.7	NOISE AND NOISE FIGURE.....	55
4.8	FIELD STRENGTH OF SPURIOUS RADIATION.....	59
5	TEST EQUIPMENT	67
6	ANTENNA FACTORS, CABLE LOSS AND SAMPLE CALCULATIONS	68
6.1	ANTENNA CHASE CBL 6111C (30 MHZ – 1 GHZ)	68
6.2	ANTENNA ROHDE & SCHWARZ HL 025 (1 GHZ – 18 GHZ)	69
6.3	ANTENNA ARA INC. MWH-1826-B (18 GHZ – 26.5 GHZ) PARTIALLY IN CONJUNCTION WITH PRE-AMPLIFIER MITEQ JS43-1800-4000: THE USE OF THE PRE-AMPLIFIER IS DEPENDENT FROM THE FIELD STRENGTH	70
7	MEASUREMENT UNCERTAINTIES.....	71
8	PHOTO REPORT	72
	Annex A: Accreditation certificate (for information)	73
	Annex B: Additional information provided by client	74



ECL-TA-20-006-V01.00

TA tests on Andrew CAP MX AC 6/7E/80-
85/17E/19/23/25T

1 APPLIED STANDARDS AND TEST SUMMARY

1.1 APPLIED STANDARDS

Type of Authorization

Certification for an Industrial Signal Booster.

Applicable FCC Rules

Prepared in accordance with the requirements of FCC Rules and Regulations as listed in 47 CFR Ch.1 Parts 2 and 20, 27. The following subparts are applicable to the results in this test report.

Part 2, Subpart J - Equipment Authorization Procedures, Certification

Part 20, Commercial Mobiles Services

§ 20.21 Signal Boosters

Part 90; Private Land Mobile Radio Services

Subpart S – Regulations Governing Licensing and Use fo Frequencies in the 806 – 824,
851 – 869, 896 – 901 and 935 – 940 MHz Bands

§ 90.635 – Limitations on power and antenna height

Subpart I – General Technical Standards

§ 90.213 – Frequency Stability

§ 90.219 – Use of signal boosters

§ 90.691 – Emission mask requirements for EA-based systems

The tests were selected and performed with reference to:

- FCC Public Notice 935210 applying "Signal Boosters Basic Certification Requirements" 935210 D02, 2019-15-04.
- FCC Public Notice 935210 applying "Measurement guidance for industrial and non-consumer signal booster, repeater and amplifier devices" 935210 D05, 2019-04-03.
- FCC Public Notice 971168 applying "Measurement guidance for certification of licensed digital transmitters" 971168 D01, 2019-04-09.
- ANSI C63.26: 2015

ECL-TA-20-006-V01.00

TA tests on Andrew CAP MX AC 6/7E/80-85/17E/19/23/25T

**Summary Test Results:**

The EUT complies with all performed tests as listed in chapter 1.3 Measurement Summary/Signatures.

1.2 FCC-IC CORRELATION TABLE

**Correlation of measurement requirements for
Industrial Signal Booster from FCC and ISED Canada**

Measurement	FCC reference	ISED reference
Effective radiated power, mean output power and zone enhancer gain	§ 2.1046 § 90.635 KDB 935210 D05 v01r04: 3.5	RSS-GEN Issue 5, 6.12 RSS-119 Issue 2, 5.4
Peak to Average Ratio	---	---
Occupied bandwidth Input-versus-output spectrum	§ 2.1049 KDB 935210 D05 v01r04:3.4	RSS-GEN Issue 5, 6.7 RSS-131 Issue 3: 5.2.2
Conducted spurious Emission at Antenna Terminal	§ 2.1051 § 90.691 KDB 935210 D05 v01r04: 3.6	RSS-GEN Issue 5, 6.13 RSS-119 Issue 12, 5.8.9.2
Out-of-band emissions limits	§ 2.1051 § 90.691 KDB 935210 D05 v01r04: 3.6	RSS-GEN Issue 5, 6.13 RSS-119 Issue 12, 5.8.9.2
Frequency stability	§ 2.1055	RSS-GEN Issue 5, 6.11 RSS-131 Issue 3: 5.2.4
Field strength of spurious radiation	§ 2.1053 § 90.691	RSS-GEN Issue 5, 6.13 RSS-119 Issue 12, 5.8.9.2
Out-of-band rejection	KDB 935210 D05 v01r04: 3.3	RSS-131 Issue 3: 5.2.1
Noise and noise figure	§ 90.213	RSS-119 Issue 3: 6.4 and 6.4
All measurements	ANSI 63.26	ANSI 63.26



ECL-TA-20-006-V01.00

TA tests on Andrew CAP MX AC 6/7E/80-85/17E/19/23/25T

1.3 MEASUREMENT SUMMARY/SIGNATURES

**47 CFR CHAPTER I FCC PART 90 Subpart S/I § 2.1046, § 90.635 (a),
[Base Stations/Repeater] KDB 935210 D02 II (p)(4)**

Effective Radiated Power, mean output power and zone enhancer gain
The measurement was performed according to ANSI C63.26, KDB 935210 D05 v01r04: 3.5

Final Result

OP-Mode

Frequency Band, Direction, Input Power, Signal Type

CELL 800, RF downlink, 0.3 dB < AGC, Narrowband

CELL 800, RF downlink, 0.3 dB < AGC, Wideband

CELL 800, RF downlink, 3 dB > AGC, Narrowband

CELL 800, RF downlink, 3 dB > AGC, Wideband

FCC

IC

Passed

Passed

Passed

Passed

Passed

Passed

Passed

Passed

**47 CFR CHAPTER I FCC PART 90 Subpart S/I
[Base Stations/Repeater]**

Peak to Average Ratio

The measurement was performed according to ANSI C63.26

Final Result

OP-Mode

Frequency Band, Direction, Input Power, Signal Type

CELL 800, RF downlink, 0.3 dB < AGC, Narrowband

CELL 800, RF downlink, 0.3 dB < AGC, Wideband

CELL 800, RF downlink, 3 dB > AGC, Narrowband

CELL 800, RF downlink, 3 dB > AGC, Wideband

FCC

IC

Passed

Passed

Passed

Passed

Passed

Passed

Passed

Passed

**47 CFR CHAPTER I FCC PART 90 Subpart S/I § 2.1049,
[Base Stations/Repeater] KDB 935210 D02 II (p)(3)**

Occupied Bandwidth/Input-versus-output Spectrum

The measurement was performed according to ANSI C63.26, KDB 935210 D05 v01r04: 3.4

Final Result

OP-Mode

Frequency Band, Direction, Input Power, Signal Type

CELL 800, RF downlink, 0.3 dB < AGC, Narrowband

CELL 800, RF downlink, 0.3 dB < AGC, Wideband

CELL 800, RF downlink, 3 dB > AGC, Narrowband

CELL 800, RF downlink, 3 dB > AGC, Wideband

FCC

IC

Passed

Passed

Passed

Passed

Passed

Passed

Passed

Passed



ECL-TA-20-006-V01.00

TA tests on Andrew CAP MX AC 6/7E/80-85/17E/19/23/25T

47 CFR CHAPTER I FCC PART 90 Subpart S/I § 2.1051, § 90.691 (a)(2) [Base Stations/Repeater]

Conducted spurious emissions at antenna terminals The measurement was performed according to ANSI C63.26 Final Result

Table with 3 columns: OP-Mode, FCC, IC. Rows include Frequency Band, Direction, Input Power, Signal Type and various test results for CELL 800 RF downlink.

47 CFR CHAPTER I FCC PART 90 Subpart S/I § 2.1053, § 90.691 (a)(2) [Base Stations/Repeater] KDB 935210 D02 II (p)(3)

Out-of-band emission limits The measurement was performed according to ANSI C63.26, KDB 935210 D05 v01r04: 3.6 Final Result

Table with 3 columns: OP-Mode, FCC, IC. Rows include Band Edge, Frequency Band, Number of signals, Direction, Input Power, Signal Type and various test results for Lower and Upper CELL 800 RF downlink.

47 CFR CHAPTER I FCC PART 90 Subpart S/I KDB 935210 D02 II (p)(2) [Base Stations/Repeater]

Out-of-band emission limits The measurement was performed according to ANSI C63.26, KDB 935210 D05 v01r04: 3.6 Final Result

Table with 3 columns: OP-Mode, FCC, IC. Rows include Band Edge, Frequency Band, Number of signals, Direction, Input Power, Signal Type and various test results for Upper and Lower CELL 800 RF downlink.



ECL-TA-20-006-V01.00

TA tests on Andrew CAP MX AC 6/7E/80-85/17E/19/23/25T

47 CFR CHAPTER I FCC PART 90 Subpart S/I KDB 935210 D02 II (p)(2)
[Base Stations/Repeater]

Out-of-band rejection
The measurement was performed according to ANSI C63.26, 935210 **Final Result**
D05 v01r04: 3.3

OP-Mode	Setup	FCC	IC
Frequency Band, Direction			
CELL 800, RF downlink		Passed	Passed

47 CFR CHAPTER I FCC PART 90 Subpart S/I § 90.219 (d) (6) (i)/(ii)/(iii),
[Base Stations/Repeater] e (3)

Noise and noise figure
The measurement was performed according to ANSI C63.26 **Final Result**

OP-Mode	Setup	FCC	IC
Frequency Band, Direction, Test Step			
CELL 800, RF downlink, passband		Passed	Passed
CELL 800, RF downlink, out of passband		Passed	Passed
CELL 800, RF downlink, noise figure		Passed	Passed

47 CFR CHAPTER I FCC PART 27 Subpart C [Base § 2.1053, § 90.691 (a)(2)
Stations/Repeater]

Field strength of spurious radiation
The measurement was performed according to ANSI C63.26 **Final Result**

OP-Mode	FCC	IC
Frequency Band, Test Frequency, Direction		
CELL 800, high, RF downlink	Passed	Passed
CELL 800, low, RF downlink	Passed	Passed
CELL 800, mid, RF downlink	Passed	Passed

The test case frequency stability was not performed, since the EUT is not equipped with signal processing capabilities.



ECL-TA-20-006-V01.00

TA tests on Andrew CAP MX AC 6/7E/80-
85/17E/19/23/25T

2 ADMINISTRATIVE DATA

2.1 TESTING LABORATORY

Bureau Veritas Consumer Products Services Germany GmbH
Thurn-und-Taxis-Straße 18
D-90411 Nürnberg
Tel.: +49 40 74041 0
Fax: +49 40 74041-2755

2.2 APPLICANT DATA

Company Name: Commscope
Andrew Wireless Systems GmbH

Address: Industriering 10
86675 Buchdorf
Germany

Contact Person: Mr. Frank Futter

2.3 MANUFACTURER DATA

Company Name: Please see applicant data.

Address:



ECL-TA-20-006-V01.00

TA tests on Andrew CAP MX AC 6/7E/80-85/17E/19/23/25T

3 TEST OBJECT DATA

3.1 GENERAL EUT DESCRIPTION

Kind of Device product description	Cellular Repeater
Product name	Cellular Repeater
Type	
Declared EUT data by the supplier	
General Product Description	The EUT is an industrial signal booster supporting the following: Band 5/CELL 850 CELL 800/USA 700E CELL 800/USA 700E Band 14/LMR 750 Band 25/PCS 1900 Band 27/CELL 800 Band 30/WCS 2300 Band 41/BRS Band 66/AWS 1700E (partly) CELL 800/CELL 800 Band 71/USA 600 A RF operation is only supported for the downlink.
Booster Type	Industrial Signal Booster
Voltage Type	AC/50 Hz – 60 Hz
Voltage Level	100 V - 240 V
Maximum Output Donor Port [Uplink]	-
Nominal Output Server Port [Downlink]	All bands: 33 dBm
Nominal Gain [Uplink]	-
Nominal Gain [Downlink]	All bands: 33 dB

The main components of the EUT are listed and described in chapter 3.2 EUT Main components.



ECL-TA-20-006-V01.00

TA tests on Andrew CAP MX AC 6/7E/80-
85/17E/19/23/25T

3.2 EUT MAIN COMPONENTS

Sample Name	FCC-ID	IC-ID
	XS5-CAPMX	2237E-CAPMX
Sample Parameter	Value	
Serial Number	8	
HW Version	7830127-0001 Rev.: 00	
SW Version	2.9.0.292	
Comment	-----	

NOTE: The short description is used to simplify the identification of the EUT in this test report.

3.3 ANCILLARY EQUIPMENT

For the purposes of this test report, ancillary equipment is defined as equipment which is used in conjunction with the EUT to provide operational and control features to the EUT. It is necessary to configure the system in a typical fashion, as a customer would normally use it. But nevertheless Ancillary Equipment can influence the test results.

Device	Details (Manufacturer, Type Model, OUT Code)	Description
-	-	-



ECL-TA-20-006-V01.00

TA tests on Andrew CAP MX AC 6/7E/80-
85/17E/19/23/25T

3.4 AUXILIARY EQUIPMENT

For the purposes of this test report, auxiliary equipment is defined as equipment which is used temporarily to enable operational and control features especially used for the tests of the EUT which is not used during normal operation or equipment that is used during the tests in combination with the EUT but is not subject of this test report. It is necessary to configure the system in a typical fashion, as a customer would normally use it. But nevertheless Auxiliary Equipment can influence the test results.

Device	Details (Manufacturer; Type; S/N)	Description
AUX1	Commscope/General Electric; ION-E PSU Shelf, AC; DM77662	Rack in Conjunction with AUX 2
AUX2	Commscope/General Electric; Power Supply Unit; LBGPE17KZ39047532	Power Supply
AUX3	Commscope; ION-E WCS-2; SZAEAJ1952A0032	Subrack in Conjunction with AUX 4, 5,6, 7 and 8
AUX4	Commscope; ION-E OPT; SZBEAD1951A0011	Optical Card
AUX5	Commscope; ION-E SUI; SZBEAC1746A0015	LAN System Interface
AUX6	Commscope; ION-E RFD; SZBEAP1920A0057	RF Card
AUX7	Commscope; ION-E RFD; SZBEAP1924A0023	RF Card
AUX 8	Commscope; ION-E RFD; SZBEAP1946A0003	RF Card



ECL-TA-20-006-V01.00

TA tests on Andrew CAP MX AC 6/7E/80-85/17E/19/23/25T

3.5 EUT SETUPS

This chapter describes the combination of EUTs and equipment used for testing. The rationale for selecting the EUTs, ancillary and auxiliary equipment and interconnecting cables, is to test a representative configuration meeting the requirements of the referenced standards.

Setup	Combination of EUTs	Description and Rationale
		Setup for all tests

OPERATING MODES

This chapter describes the operating modes of the EUT used for testing.

3.5.1 TEST CHANNELS

Band	Direction	Lower Frequency Band Edge [MHz]	Upper Frequency Band Edge [MHz]	Center Frequency [MHz]	Port
Band 27, CELL 800	Downlink	862.00	865.50	869.00	Donor

3.5.2 AUTOMATIC GAIN CONTROL LEVELS

AGC Levels							
Band	Direction	Signal Type	AGC Start Pin [dBm]	AGC Start Pin -0.3 dB [dBm]	AGC Start Pin +3 dB [dBm]	Frequency [MHz]	Frequency
27	Downlink	Narrowband	-1.6	-1.9	1.4	865.50	Mid
27	Downlink	Wideband	-1.6	-1.9	1.4	865.50	
27	Downlink	Narrowband	-1.8	-2.1	1.2	862.20	Low
27	Downlink	Wideband	-1.6	-1.9	1.4	864.50	
27	Downlink	Narrowband	-1.6	-1.9	1.4	868.80	High
27	Downlink	Wideband	-1.6	-1.9	1.4	866.50	
27	Downlink	Narrowband	-2.0	-2.3	1.0	867.65	Max.Power
27	Downlink	Wideband	-1.6	-1.9	1.4	866.50	

Remark:

If the measured frequency f_0 for the max power has a too low distance to the band edges, because in the tests modulated signals must be used: The next possible frequency to the according band edge is used.

For example for minimum distances to the band edges:

GSM-Signal (narrowband): 0.2 MHz

AWGN-signal (wideband): 2.5 MHz



BUREAU
VERITAS

ECL-TA-20-006-V01.00

TA tests on Andrew CAP MX AC 6/7E/80-
85/17E/19/23/25T

3.6 PRODUCT LABELLING

3.6.1 FCC ID LABEL

Please refer to the documentation of the applicant.

3.6.2 LOCATION OF THE LABEL ON THE EUT

Please refer to the documentation of the applicant.



ECL-TA-20-006-V01.00

TA tests on Andrew CAP MX AC 6/7E/80-85/17E/19/23/25T

4 TEST RESULTS

4.1 EFFECTIVE RADIATED POWER, MEAN OUTPUT POWER AND ZONE ENHANCER GAIN

Standard FCC Part 27, § 27.50

The test was performed according to:
ANSI C63.26, KDB 935210 D05 v01r04: 3.5

Test date: 2020-07-22

Environmental conditions: 25 ° C; 40 % r. F.

Test engineer: Thomas Hufnagel

4.1.1 TEST DESCRIPTION

This test case is intended to demonstrate compliance to the signal booster power and gain limits and requirements for industrial signal boosters per FCC § 90.635 and RSS-119 with subpart 5.4.

The EUT was connected to the test setup according to the following diagram:

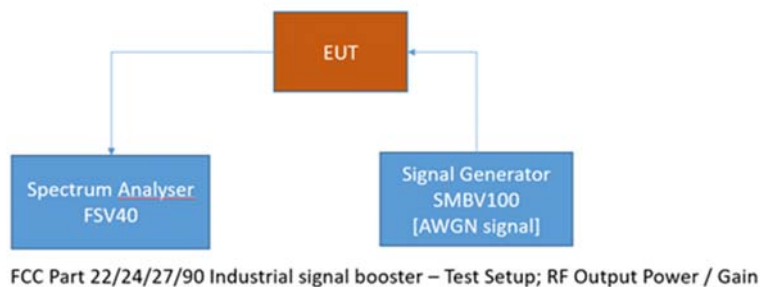

The attenuation of the measuring and stimulus path are known for each measured frequency and are considered.

The Spectrum Analyzer settings can be directly found in the measurement diagrams.



**BUREAU
VERITAS**

ECL-TA-20-006-V01.00

TA tests on Andrew CAP MX AC 6/7E/80-
85/17E/19/23/25T

4.1.2 TEST REQUIREMENTS/LIMITS: ABSTRACTS FROM STANDARDS

Part 27; Miscellaneous Wireless Communication Services

Subpart C – Technical standards

§ 90.635

CELL 800:

Abstract § 90.635 from FCC:

Band 862 MHz – 869 MHz

§ 90.635

(a) The effective radiated power and antenna height for base stations may not exceed 1 kilowatt (30 dBw) and 304 m. (1,000 ft.) above average terrain (AAT), respectively, or the equivalent thereof as determined from the Table. These are maximum values, and applicants will be required to justify power levels and antenna heights requested.



ECL-TA-20-006-V01.00

TA tests on Andrew CAP MX AC 6/7E/80-85/17E/19/23/25T

Abstract RSS-119 from ISED:

RSS-119; 5.4 Transmitter Output Power

Table 2 – Transmitter Output Power

Frequency Bands (MHz)	Transmitter Output Power (W)	
	Base/Fixed Equipment	Mobile Equipment
27.41-28 and 29.7-50	300	30
72-76	No limit	1
138-174	110	60
217-218 and 219-220	110	30*
220-222	See SRSP-512 for ERP limit	50
406.1-430 and 450-470	110	60
768-776 and 798-806	See SRSP-511 for ERP limit	30 3 W ERP for portable equipment
806-821/851-866 and 821-824/866-869	110	30
896-901/935-940	110	60
929-930/931-932	110	30
928-929/952-953 and 932-932.5/941-941.5	110	30
932.5-935/941.5-944	110	30

*Equipment is generally authorized for effective radiated power (ERP) of less than 5 W.



ECL-TA-20-006-V01.00

TA tests on Andrew CAP MX AC 6/7E/80-85/17E/19/23/25T

4.1.3 TEST PROTOCOL

CELL 800, downlink							
Signal Type	Input Power	Frequency [MHz]	Input Power [dBm]	Maximum Average Output Power [dBm]	Limit Average Output Power [dBm]	Margin to Limit [dB]	Gain [dB]
Wideband	0.3 dB < AGC	866.50	-1.9	30.0	50.4	20.4	31.9
Wideband	3 dB > AGC	866.50	-1.4	30.4	50.4	20.0	31.8
Narrowband	0.3 dB < AGC	867.65	-2.3	30.2	50.4	20.2	32.5
Narrowband	3 dB > AGC	867.65	-1.0	30.3	50.4	20.1	31.3

Remarks: Please see next sub-clause for the measurement plot.



BUREAU
VERITAS

ECL-TA-20-006-V01.00

TA tests on Andrew CAP MX AC 6/7E/80-85/17E/19/23/25T

4.1.1.4 MEASUREMENT PLOT

Band: CELL 800; Frequency: 867.6500 MHz; Band Edge: f0; Mod: AWGN; Output Power 0.3 dB < AGC

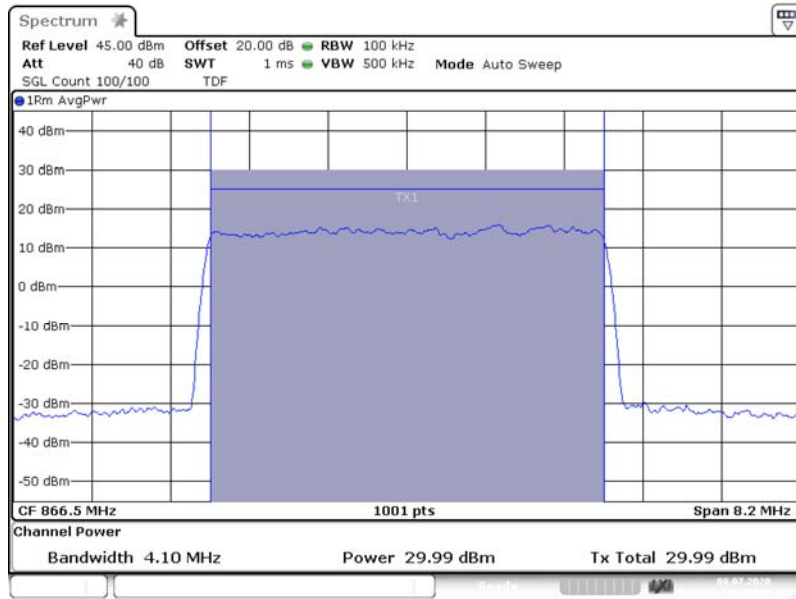

3.5.3 Power AWGN Out -0.3 866.50000M

Band: CELL 800; Frequency: 867.6500 MHz; Band Edge: f0; Mod: AWGN; Output Power 3 dB > AGC

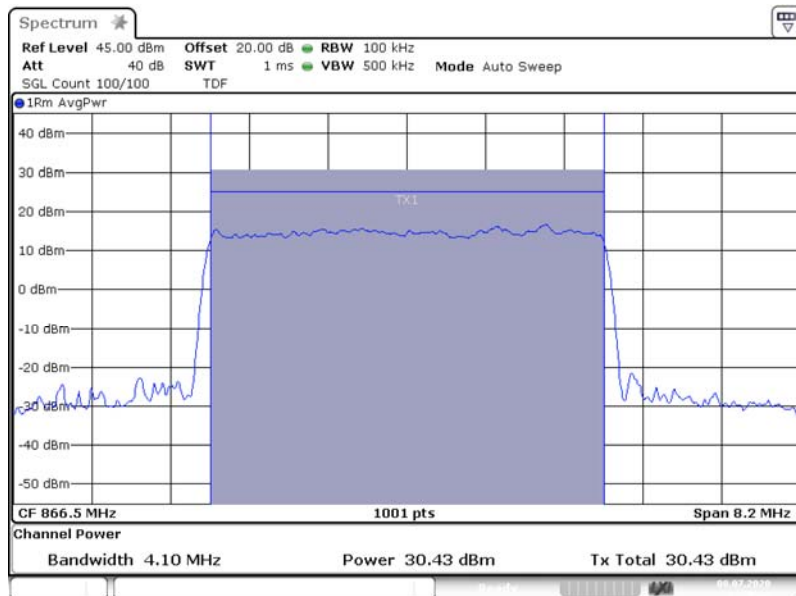

3.5.3 Power AWGN Out +3 866.50000M



BUREAU
VERITAS

ECL-TA-20-006-V01.00

TA tests on Andrew CAP MX AC 6/7E/80-85/17E/19/23/25T

Band: CELL 800; Frequency: 867.6500 MHz; Band Edge: f0; Mod: GSM; Output Power 0.3 dB < AGC



Band: CELL 800; Frequency: 867.6500 MHz; Band Edge: f0; Mod: GSM; Output Power 3 dB > AGC



4.1.5 TEST EQUIPMENT USED

- Conducted

ECL-TA-20-006-V01.00

TA tests on Andrew CAP MX AC 6/7E/80-
85/17E/19/23/25T

4.2 PEAK TO AVERAGE RATIO

Standard FCC Part 27, § 27.50

The test was performed according to:
ANSI C63.26

Test date: 2020-07-22

Environmental conditions: 25 ° C; 40 % r. F.

Test engineer: Thomas Hufnagel

4.2.1 TEST DESCRIPTION

This test case is intended to measure the peak to average ratio.

The EUT was connected to the test setup according to the following diagram:

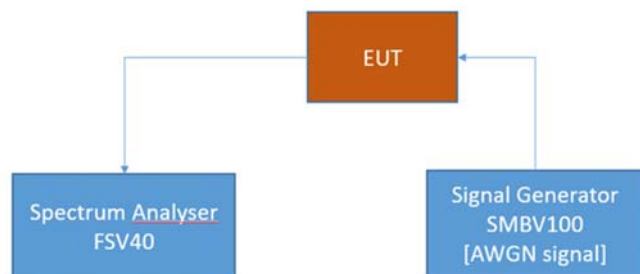

FCC Part 22/24/27/90 Industrial signal booster – Test Setup; RF Output Power / Gain

The attenuation of the measuring and stimulus path are known for each measured frequency and are considered.

The Spectrum Analyser settings can be directly found in the measurement diagrams.



ECL-TA-20-006-V01.00

TA tests on Andrew CAP MX AC 6/7E/80-85/17E/19/23/25T

4.2.2 TEST REQUIREMENTS/LIMITS

There is no requirement for the Peak-to-Average value in the applicable rule parts.

4.2.3 TEST PROTOCOL

CELL 800, downlink						
Signal Type	Input Power	Frequency [MHz]	Input Power [dBm]	PAPR [dB]	Fictive Limit PAPR [dB]	Margin to Limit [dB]
Wideband	0.3 dB < AGC	865.50	-1.9	8.9	13.0	4.1
Wideband	3 dB > AGC	865.50	1.4	8.9	13.0	4.1
Narrowband	0.3 dB < AGC	865.50	-1.9	0.2	13.0	12.8
Narrowband	3 dB > AGC	865.50	1.4	0.2	13.0	12.8

Remark: Please see next sub-clause for the measurement plot.



BUREAU
VERITAS

ECL-TA-20-006-V01.00

TA tests on Andrew CAP MX AC 6/7E/80-
85/17E/19/23/25T

4.2.4 MEASUREMENT PLOT (SHOWING THE HIGHEST VALUE, "WORST CASE")

Band: CELL 800; Frequency: 865.5000 MHz; Band Edge: mid; Mod: AWGN; PAPR 0.3 dB < AGC

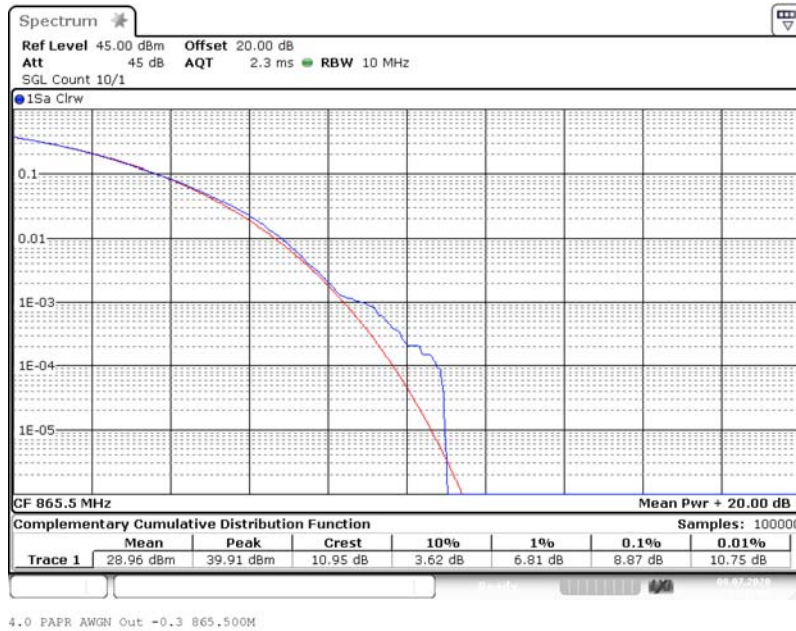

Band: CELL 800; Frequency: 865.5000 MHz; Band Edge: mid; Mod: AWGN; PAPR 3 dB > AGC

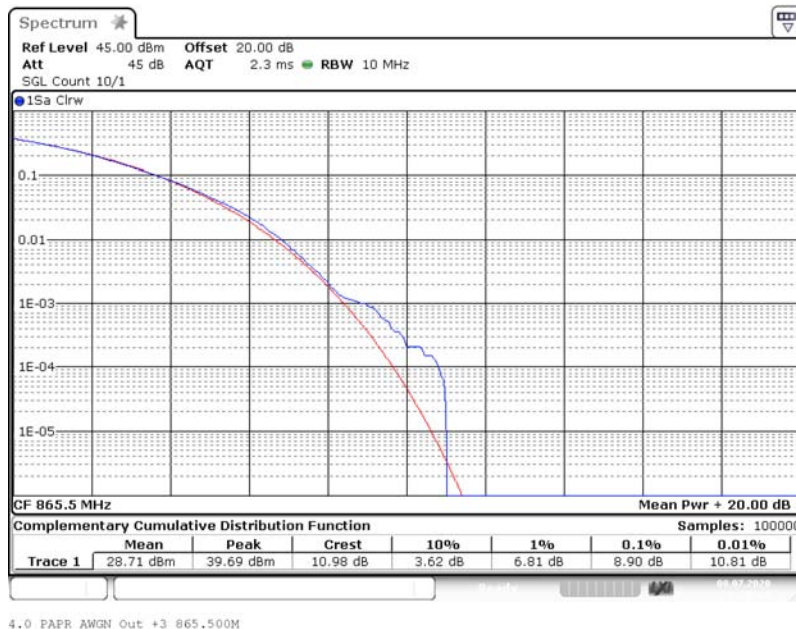



**BUREAU
VERITAS**

ECL-TA-20-006-V01.00

TA tests on Andrew CAP MX AC 6/7E/80-85/17E/19/23/25T

Band: CELL 800; Frequency: 865.5000 MHz; Band Edge: mid; Mod: GSM; PAPR 0.3 dB < AGC

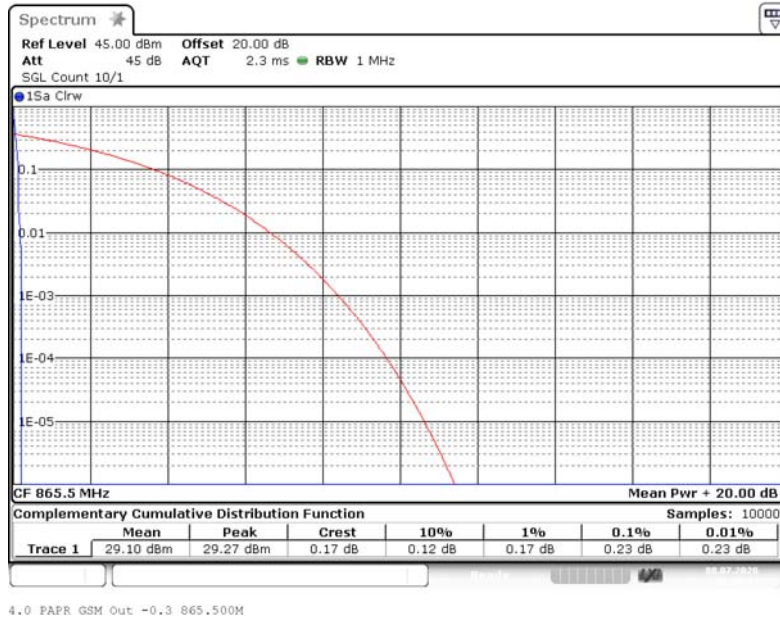

Band: CELL 800; Frequency: 865.5000 MHz; Band Edge: mid; Mod: GSM; PAPR 3 dB > AGC

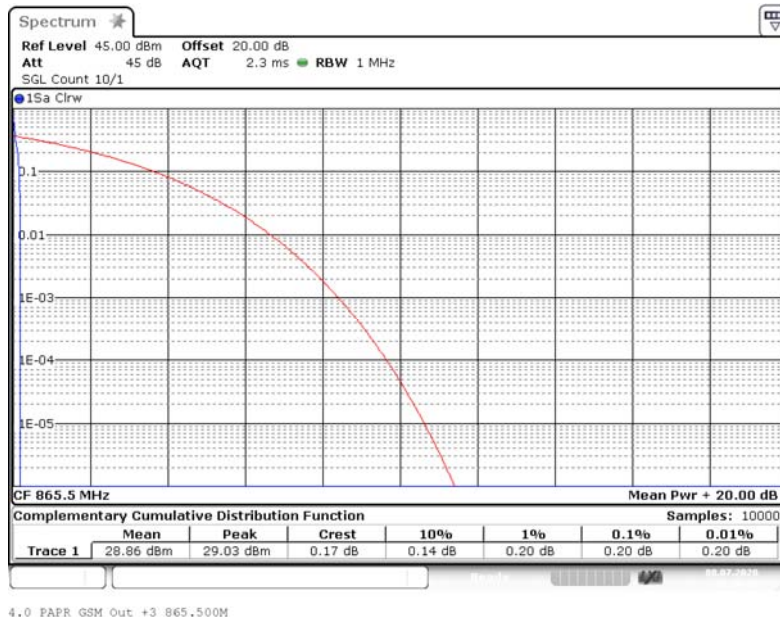

4.2.5 TEST EQUIPMENT USED

- Conducted

ECL-TA-20-006-V01.00

TA tests on Andrew CAP MX AC 6/7E/80-85/17E/19/23/25T

4.3 OCCUPIED BANDWIDTH/INPUT-VERSUS-OUTPUT SPECTRUM

Standard FCC Part 2.1049; Occupied Bandwidth

The test was performed according to:
ANSI C63.26, KDB 935210 D05 v01r04: 3.4

Test date: 2020-07-22

Environmental conditions: 25 ° C; 40 % r. F.

Test engineer: Thomas Hufnagel

4.3.1 TEST DESCRIPTION

This test case is intended to demonstrate compliance to the applicable conducted spurious emission limits per FCC § 2.1049, RSS-GEN with subpart 6.7 and RSS-131 with subpart 5.2.2

The EUT was connected to the test setups according to the following diagram:

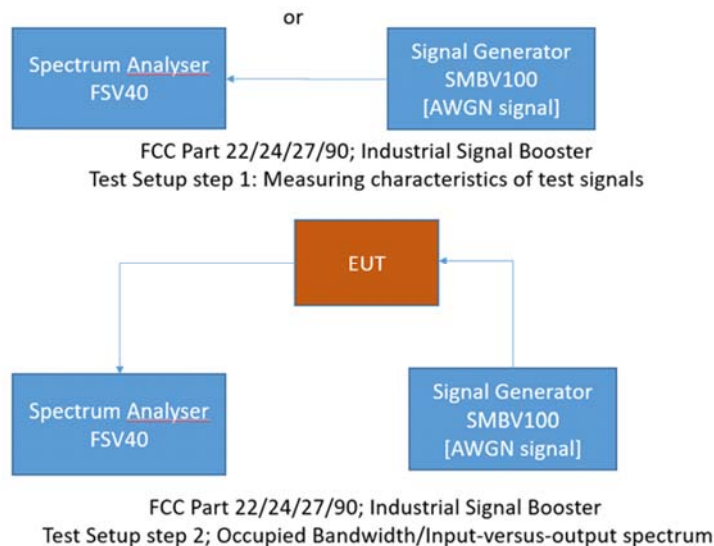

The attenuation of the measuring and stimulus path are known for each measured frequency and are considered.

The Spectrum Analyzer settings can be directly found in the measurement diagrams.



ECL-TA-20-006-V01.00

TA tests on Andrew CAP MX AC 6/7E/80-
85/17E/19/23/25T

4.3.2 TEST REQUIREMENTS/LIMITS

Abstract § 2.1049 from FCC:

FCC Part 2.1049; Occupied Bandwidth:

The occupied bandwidth, that is the frequency bandwidth such that, below its lower and above its upper frequency limits, the mean powers radiated are each equal to 0.3 percent of the total mean power radiated by a given emission shall be measured under the following conditions as applicable:

(h) Transmitters employing digital modulation techniques—when modulated by an input signal such that its amplitude and symbol rate represent the maximum rated conditions under which the equipment will be operated. The signal shall be applied through any filter networks, pseudo-random generators or other devices required in normal service. Additionally, the occupied bandwidth shall be shown for operation with any devices used for modifying the spectrum when such devices are optional at the discretion of the user.

(i) Transmitters designed for other types of modulation—when modulated by an appropriate signal of sufficient amplitude to be representative of the type of service in which used. A description of the input signal should be supplied.

Abstract RSS-GEN from ISED:

RSS-GEN; 6.7 Occupied Bandwidth

The occupied bandwidth or the “99% emission bandwidth” is defined as the frequency range between two points, one above and the other below the carrier frequency, within which 99% of the total transmitted power of the fundamental transmitted emission is contained. The occupied bandwidth shall be reported for all equipment in addition to the specified bandwidth required in the applicable RSSs.

In some cases, the “x dB bandwidth” is required, which is defined as the frequency range between two points, one at the lowest frequency below and one at the highest frequency above the carrier frequency, at which the maximum power level of the transmitted emission is attenuated x dB below the maximum in-band power level of the modulated signal, where the two points are on the outskirts of the in-band emission.

The following conditions shall be observed for measuring the occupied bandwidth and x dB bandwidth:

- The transmitter shall be operated at its maximum carrier power measured under normal test conditions.
- The span of the spectrum analyzer shall be set large enough to capture all products of the modulation process, including the emission skirts, around the carrier frequency, but small enough to avoid having other emissions (e.g. on adjacent channels) within the span.



**BUREAU
VERITAS**

ECL-TA-20-006-V01.00

TA tests on Andrew CAP MX AC 6/7E/80-
85/17E/19/23/25T

- The detector of the spectrum analyzer shall be set to "Sample". However, a peak, or peak hold, may be used in place of the sampling detector since this usually produces a wider bandwidth than the actual bandwidth (worst-case measurement). Use of a peak hold (or "Max Hold") may be necessary to determine the occupied / x dB bandwidth if the device is not transmitting continuously.
- The resolution bandwidth (RBW) shall be in the range of 1% to 5% of the actual occupied / x dB bandwidth and the video bandwidth (VBW) shall not be smaller than three times the RBW value. Video averaging is not permitted.

For the 99% emission bandwidth, the trace data points are recovered and directly summed in linear power level terms. The recovered amplitude data points, beginning at the lowest frequency, are placed in a running sum until 0.5% of the total is reached, and that frequency recorded. The process is repeated for the highest frequency data points (starting at the highest frequency, at the right side of the span, and going down in frequency). This frequency is then recorded. The difference between the two recorded frequencies is the occupied bandwidth (or the 99% emission bandwidth).

Abstract RSS-131 from ISED:

RSS-131; 5.2.2 Input-versus-output spectrum

The spectral growth of the 26 dB bandwidth of the output signal shall be less than 5% of the input signal spectrum.



ECL-TA-20-006-V01.00

TA tests on Andrew CAP MX AC 6/7E/80-85/17E/19/23/25T

4.3.3 TEST PROTOCOL

CELL 800, downlink							
Signal Type	Input Power	Signal Frequency [MHz]	Occupied Bandwidth SG [kHz]	Occupied Bandwidth Booster [kHz]	Delta Occupied Bandwidth [kHz]	Limit Delta Occupied Bandwidth [kHz]	Margin to Limit [kHz]
Wideband	0.3 dB < AGC	865.50	4336.5	4336.5	0.0	205.0	205.0
Wideband	3 dB > AGC	865.50	4335.3	4337.8	2.5	205.0	202.5
Narrowband	0.3 dB < AGC	865.50	318.1	314.7	3.4	10.0	6.6
Narrowband	3 dB > AGC	865.50	315.7	316.3	0.6	10.0	9.4

Remark: Please see next sub-clause for the measurement plot.



BUREAU VERITAS

ECL-TA-20-006-V01.00

TA tests on Andrew CAP MX AC 6/7E/80-85/17E/19/23/25T

4.3.4 MEASUREMENT PLOT

Band: CELL 800; Frequency: 865.5000 MHz; Band Edge: mid; Mod: AWGN; Input OCBw 0.3 dB < AGC

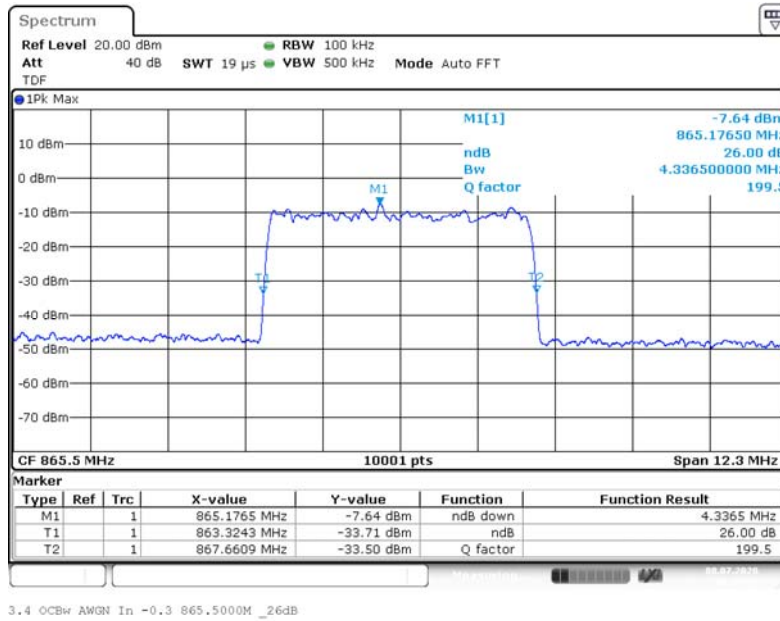

Input Signal

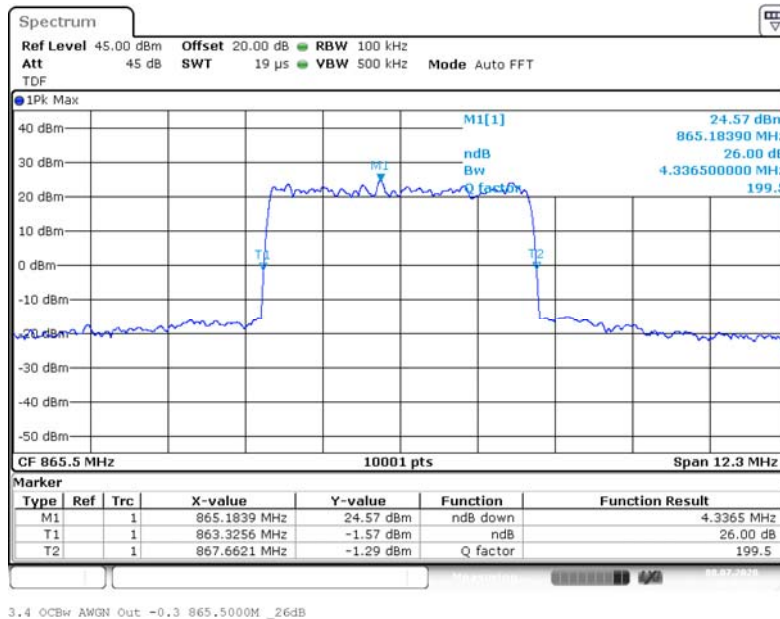

Output Signal



BUREAU VERITAS

ECL-TA-20-006-V01.00

TA tests on Andrew CAP MX AC 6/7E/80-85/17E/19/23/25T

Band: CELL 800; Frequency: 865.5000 MHz; Band Edge: mid; Mod: AWGN; Input OCBw 3 dB > AGC

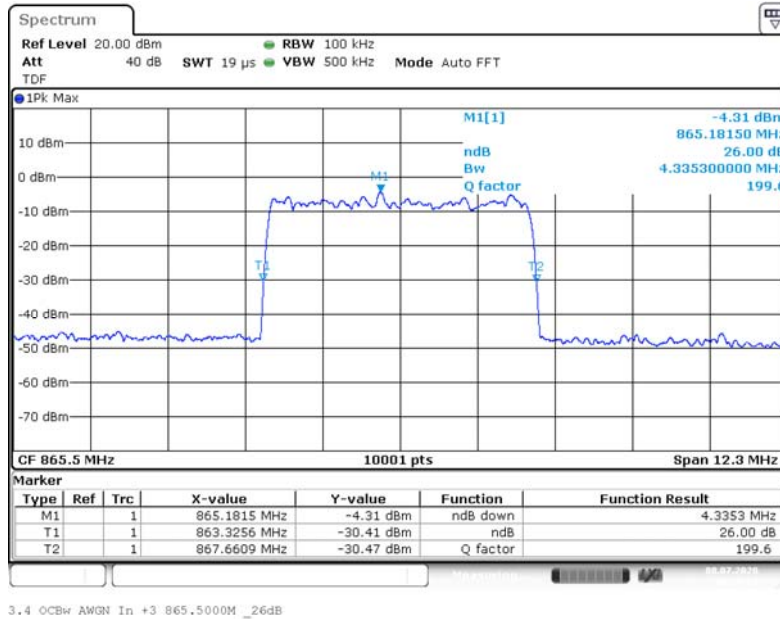

Input Signal

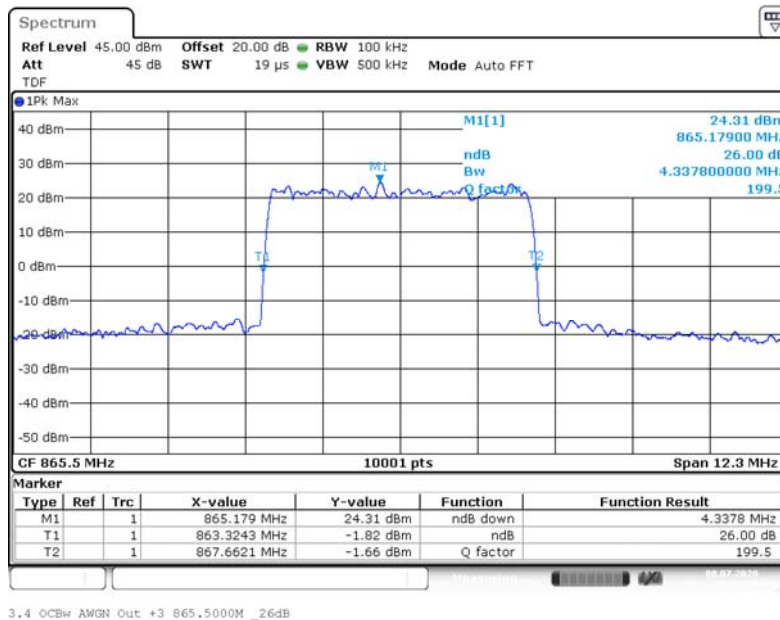

Output Signal



BUREAU VERITAS

ECL-TA-20-006-V01.00

TA tests on Andrew CAP MX AC 6/7E/80-85/17E/19/23/25T

Band: CELL 800; Frequency: 865.5000 MHz; Band Edge: mid; Mod: GSM; Input OCBw 0.3 dB < AGC

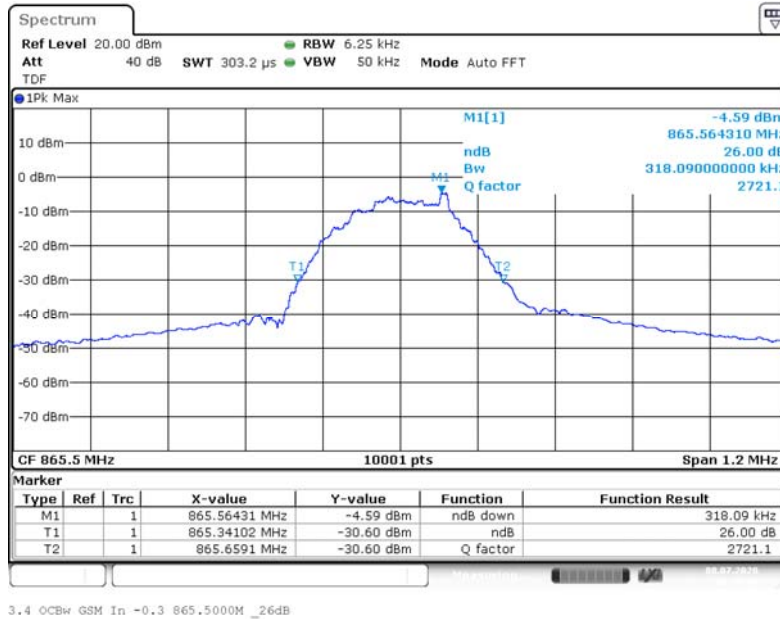

Input Signal

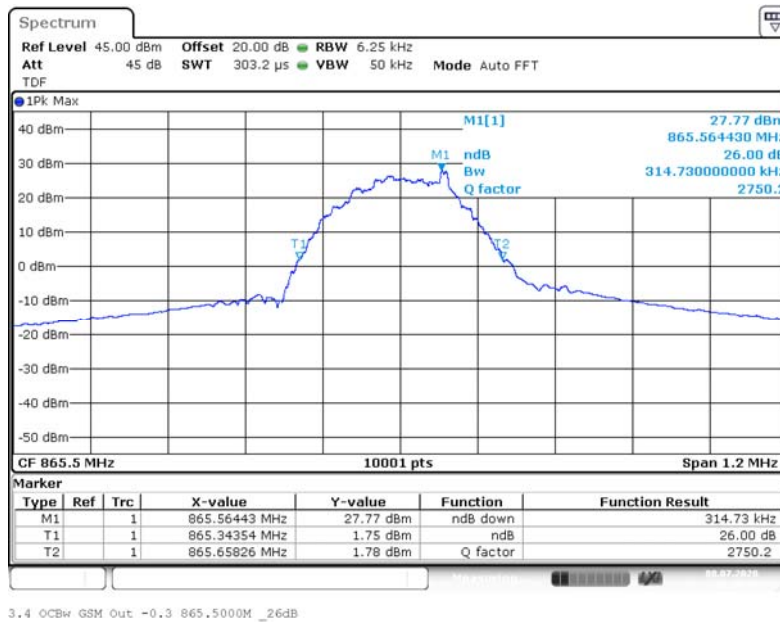

Output Signal



BUREAU VERITAS

ECL-TA-20-006-V01.00

TA tests on Andrew CAP MX AC 6/7E/80-85/17E/19/23/25T

Band: CELL 800; Frequency: 865.5000 MHz; Band Edge: mid; Mod: GSM; Input OCBw 3 dB > AGC

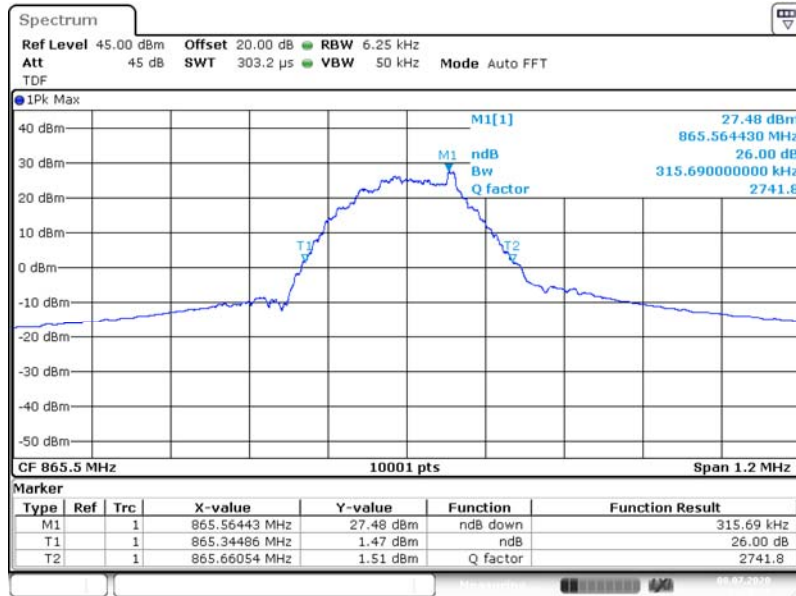

3.4 OCBw GSM Out +3 865.5000M _26dB

Input Signal

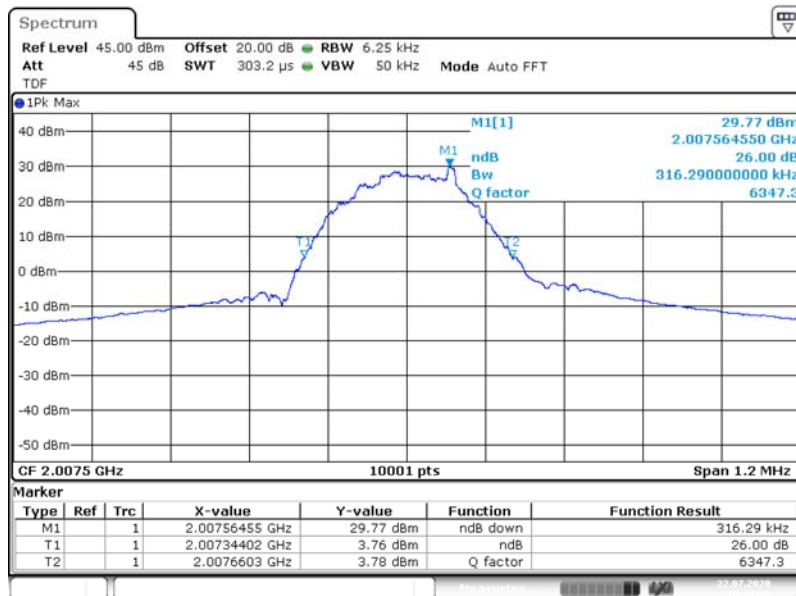

3.4 OCBw GSM Out +3 2.0075G _26dB

Output Signal

4.3.5 TEST EQUIPMENT USED

- Conducted



ECL-TA-20-006-V01.00

TA tests on Andrew CAP MX AC 6/7E/80-
85/17E/19/23/25T

4.4 CONDUCTED SPURIOUS EMISSIONS AT ANTENNA TERMINALS

Standard FCC Part § 2.1051, § 27.53

The test was performed according to:
ANSI C63.26, KDB 935210 D05 v01r04: 3.6

Test date: 2020-09-09

Environmental conditions: 24 ° C; 43 % r. F.

Test engineer: Thomas Hufnagel

4.4.1 TEST DESCRIPTION

This test case is intended to demonstrate compliance to the signal booster power and gain limits and requirements for industrial signal boosters per FCC § 2.1051, FCC § 27.53, RSS-GEN with subpart 6.13 and RSS-130 with subpart 4.7

The EUT was connected to the test setup according to the following diagram:

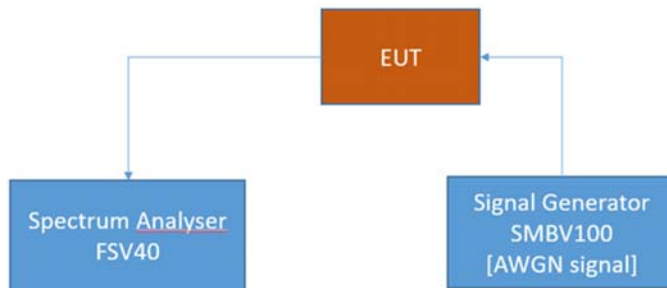

FCC Part 22/24/27/90 Industrial signal booster – Test Setup; RF Output Power / Gain

The attenuation of the measuring and stimulus path are known for each measured frequency and are considered.

The Spectrum Analyser settings can be directly found in the measurement diagrams.



ECL-TA-20-006-V01.00

TA tests on Andrew CAP MX AC 6/7E/80-
85/17E/19/23/25T

4.4.2 TEST REQUIREMENTS/LIMITS

Abstract § 2.1051 from FCC:

FCC Part 2.1051; Measurement required: Spurious emissions at antenna terminal:

The radio frequency voltage or powers generated within the equipment and appearing on a spurious frequency shall be checked at the equipment output terminals when properly loaded with a suitable artificial antenna. Curves or equivalent data shall show the magnitude of each harmonic and other spurious emission that can be detected when the equipment is operated under the conditions specified in § 2.1049 as appropriate. The magnitude of spurious emissions which are attenuated more than 20 dB below the permissible value need not be specified.

Abstract § 90.691 FCC:

§ 90.691 Emission mask requirements for EA-based systems.

(a) Out-of-band emission requirement shall apply only to the "outer" channels included in an EA license and to spectrum adjacent to interior channels used by incumbent licensees. The emission limits are as follows:

(2) For any frequency removed from the EA licensee's frequency block greater than 37.5 kHz, the power of any emission shall be attenuated below the transmitter power (P) in watts by at least $43 + 10\log_{10}(P)$ decibels or 80 decibels, whichever is the lesser attenuation, where f is the frequency removed from the center of the outer channel in the block in kilohertz and where f is greater than 37.5 kHz.

Abstract RSS-119 5.8.9.2 from ISED:

5.8.9.2 Out-of-Band Emission Limit

On any frequency outside of the ranges specified in the ACP tables 13 to 16, the power of any emission shall be attenuated below the mean output power P (dBW) by at least $43 + 10\log_{10}(p)$, measured in a 100 kHz bandwidth for frequencies less than or equal to 1 GHz, and in a 1 MHz bandwidth for frequencies greater than 1 GHz..



ECL-TA-20-006-V01.00

TA tests on Andrew CAP MX AC 6/7E/80-
85/17E/19/23/25T

4.4.3 TEST PROTOCOL

CELL 800, downlink							
Test Frequency	Signal Type	Spurious Freq. [MHz]	Spurious Level [dBm]	Detector	RBW [kHz]	Limit [dBm]	Margin to Limit [dB]
low	Wideband	0.0128706	-60.3	RMS	1	-33.0	27.3
low	Wideband	0.0624979	-52.2	RMS	10	-23.0	29.2
low	Wideband	119.1655	-45.2	RMS	100	-13.0	32.2
low	Wideband	702.9962	-44.5	RMS	100	-13.0	31.5
low	Wideband	861.6826	-37.8	RMS	10	-13.0	24.8
low	Wideband	869.3823	-41.7	RMS	10	-13.0	28.7
low	Wideband	949.6456	-43.9	RMS	100	-13.0	30.9
low	Wideband	6883.9	-30.6	RMS	1000	-13.0	17.6
mid	Wideband	0.0194241	-59.2	RMS	1	-33.0	26.2
mid	Wideband	0.1574821	-52.2	RMS	10	-23.0	29.2
mid	Wideband	128.1146	-45.1	RMS	100	-13.0	32.1
mid	Wideband	703.5962	-44.9	RMS	100	-13.0	31.9
mid	Wideband	861.7276	-38.3	RMS	10	-13.0	25.3
mid	Wideband	869.3674	-40.2	RMS	10	-13.0	27.2
mid	Wideband	950.1954	-43.6	RMS	100	-13.0	30.6
mid	Wideband	6934.9	-31.0	RMS	1000	-13.0	18.0
high	Wideband	0.0197108	-60.6	RMS	1	-33.0	27.6
high	Wideband	0.0574988	-53.4	RMS	10	-23.0	30.4
high	Wideband	68.9209	-44.6	RMS	100	-13.0	31.6
high	Wideband	703.4462	-44.7	RMS	100	-13.0	31.7
high	Wideband	861.5827	-42.4	RMS	10	-13.0	29.4
high	Wideband	869.4573	-36.6	RMS	10	-13.0	23.6
high	Wideband	954.5436	-44.0	RMS	100	-13.0	31.0
high	Wideband	6990.9	-31.1	RMS	1000	-13.0	18.1



ECL-TA-20-006-V01.00

TA tests on Andrew CAP MX AC 6/7E/80-
85/17E/19/23/25T

CELL 800, downlink							
Test Frequency	Signal Type	Spurious Freq. [MHz]	Spurious Level [dBm]	Detector	RBW [kHz]	Limit [dBm]	Margin to Limit [dB]
low	Narrowband	0.0105769	-60.8	RMS	1	-33.0	27.8
low	Narrowband	0.0574988	-56.1	RMS	10	-23.0	33.1
low	Narrowband	121.2653	-44.9	RMS	100	-13.0	31.9
low	Narrowband	703.6961	-44.6	RMS	100	-13.0	31.6
low	Narrowband	861.8975	-41.2	RMS	10	-13.0	28.2
low	Narrowband	877.9975	-45.2	RMS	10	-13.0	32.2
low	Narrowband	887.2212	-42.5	RMS	100	-13.0	29.5
low	Narrowband	6850.4	-31.2	RMS	1000	-13.0	18.2
mid	Narrowband	0.0093482	-60.8	RMS	1	-33.0	27.8
mid	Narrowband	0.1924762	-55.8	RMS	10	-23.0	32.8
mid	Narrowband	66.1212	-45.6	RMS	100	-13.0	32.6
mid	Narrowband	704.396	-44.5	RMS	100	-13.0	31.5
mid	Narrowband	861.8825	-55.0	RMS	10	-13.0	42.0
mid	Narrowband	877.9975	-45.2	RMS	10	-13.0	32.2
mid	Narrowband	890.5199	-40.5	RMS	100	-13.0	27.5
mid	Narrowband	6939.9	-31.1	RMS	1000	-13.0	18.1
high	Narrowband	0.0093891	-59.2	RMS	1	-33.0	26.2
high	Narrowband	0.1524829	-55.3	RMS	10	-23.0	32.3
high	Narrowband	121.1653	-45.3	RMS	100	-13.0	32.3
high	Narrowband	804.6319	-44.6	RMS	100	-13.0	31.6
high	Narrowband	861.4977	-55.8	RMS	10	-13.0	42.8
high	Narrowband	869.1025	-40.6	RMS	10	-13.0	27.6
high	Narrowband	951.7948	-43.4	RMS	100	-13.0	30.4
high	Narrowband	6893.9	-31.1	RMS	1000	-13.0	18.1

Remark: Please see next sub-clause for the measurement plot.



BUREAU
VERITAS

ECL-TA-20-006-V01.00

TA tests on Andrew CAP MX AC 6/7E/80-
85/17E/19/23/25T

General considerations concerning the measurement plots:

The measuring bandwidth of 100 kHz was chosen according the test requirements except at the band edges: At the band edges reducing of measurement bandwidth was necessary to prevent overlaying the RF-signal over the spurious emissions.

Also outside the downlink frequency band at lower frequencies the measurement bandwidths were reduced to have the possibility to record the spurious emissions at these lower frequencies.

At frequencies where measuring bandwidths were reduced also the border lines were reduced according the given formula:

$$p_{RBW_{reduced}} [dBm] = 10 * \log \left(RBW_{reduced} [kHz] - 100 \text{ kHz} \right) + p_{RBW 100 \text{ kHz}} [dBm]$$

Hereby "p" are the border lines' values.



BUREAU
VERITAS

ECL-TA-20-006-V01.00

TA tests on Andrew CAP MX AC 6/7E/80-
85/17E/19/23/25T

4.4.4 MEASUREMENT PLOT (SHOWING THE HIGHEST VALUE, "WORST CASE")

Frequency Band = CELL 800, Test Frequency = low, Direction = RF downlink, Signal Type = AWGN

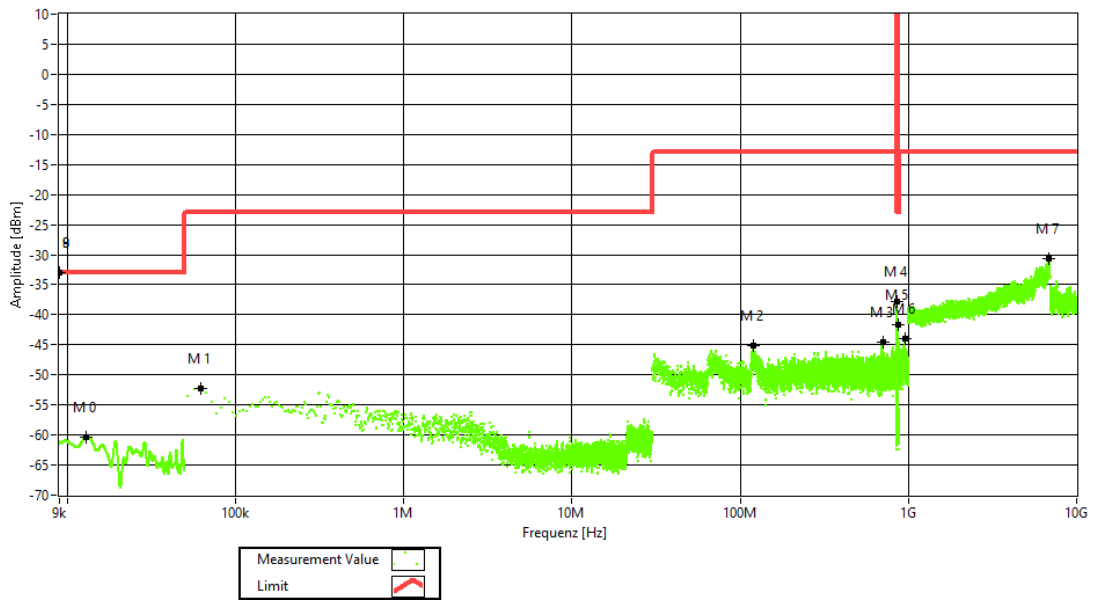

Frequency Band = CELL 800, Test Frequency = mid, Direction = RF downlink, Signal Type = AWGN

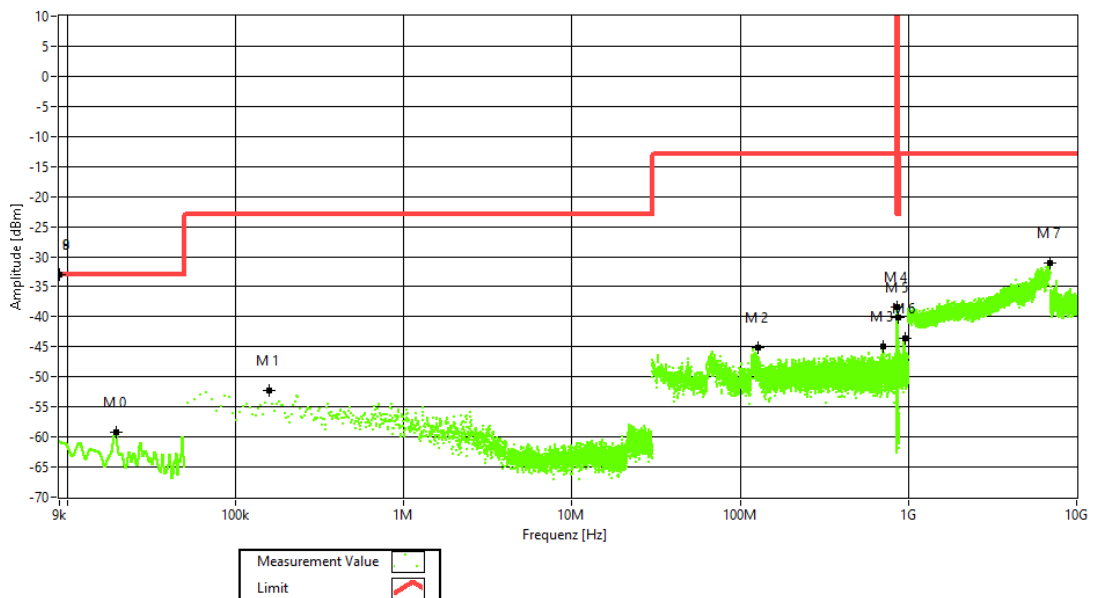



BUREAU
VERITAS

ECL-TA-20-006-V01.00

TA tests on Andrew CAP MX AC 6/7E/80-
85/17E/19/23/25T

Frequency Band = CELL 800, Test Frequency = high, Direction = RF downlink, Signal Type = AWGN

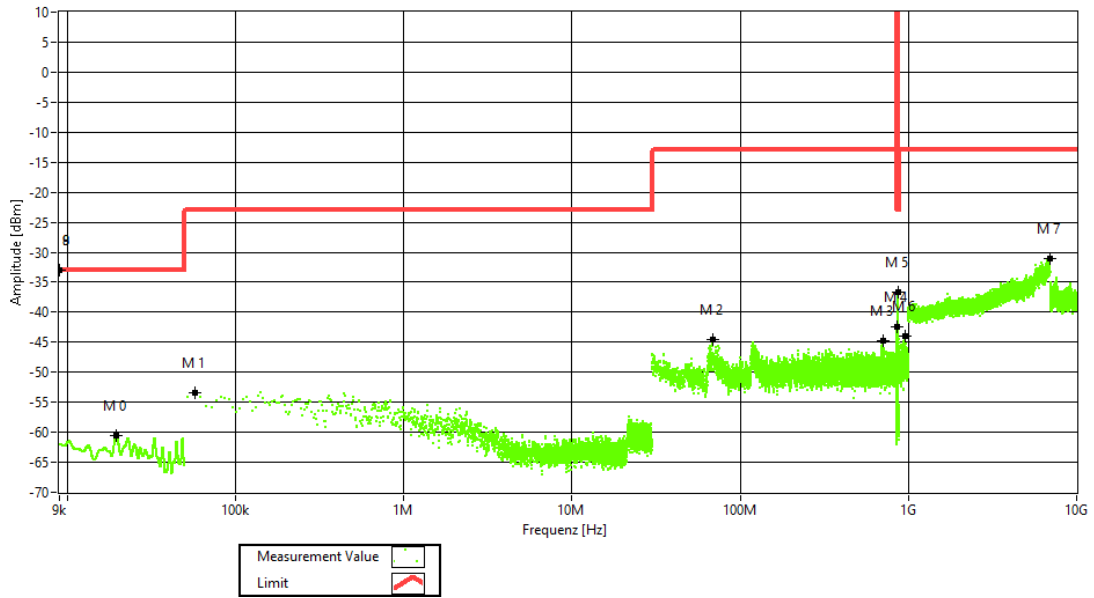



BUREAU
VERITAS

ECL-TA-20-006-V01.00

TA tests on Andrew CAP MX AC 6/7E/80-
85/17E/19/23/25T

Frequency Band = CELL 800, Test Frequency = low, Direction = RF downlink, Signal Type = GSM

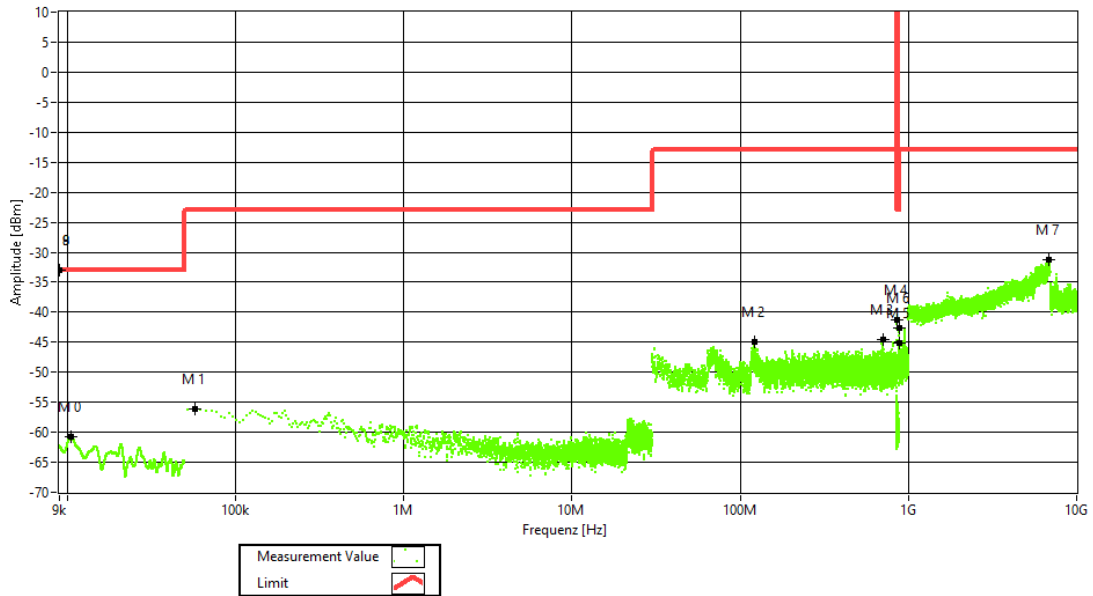

Frequency Band = CELL 800, Test Frequency = mid, Direction = RF downlink, Signal Type = GSM

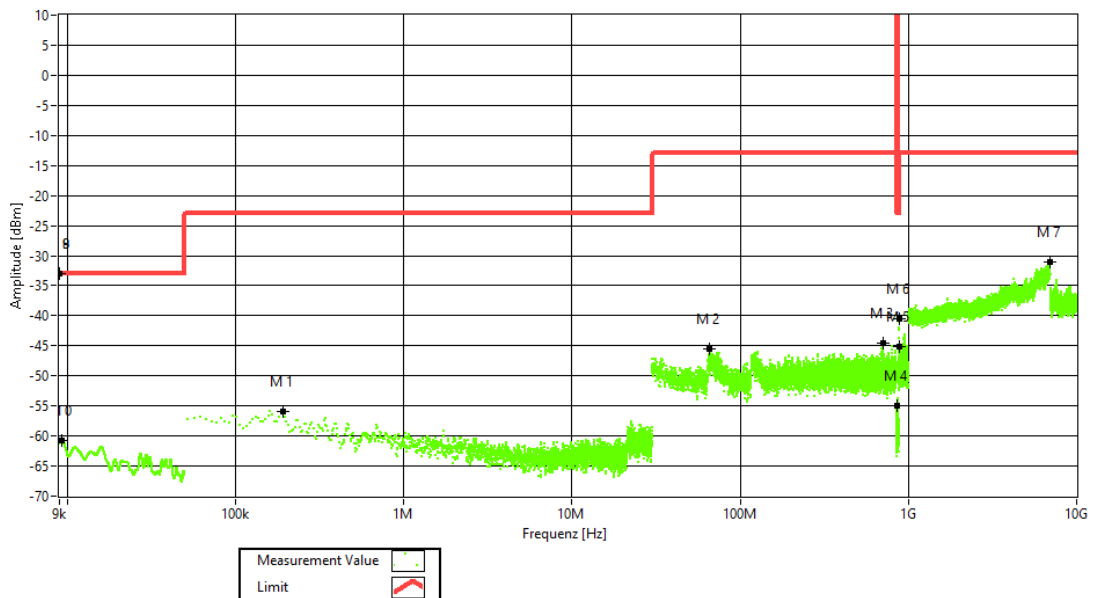



BUREAU
VERITAS

ECL-TA-20-006-V01.00

TA tests on Andrew CAP MX AC 6/7E/80-
85/17E/19/23/25T

Frequency Band = CELL 800, Test Frequency = high, Direction = RF downlink, Signal Type = GSM

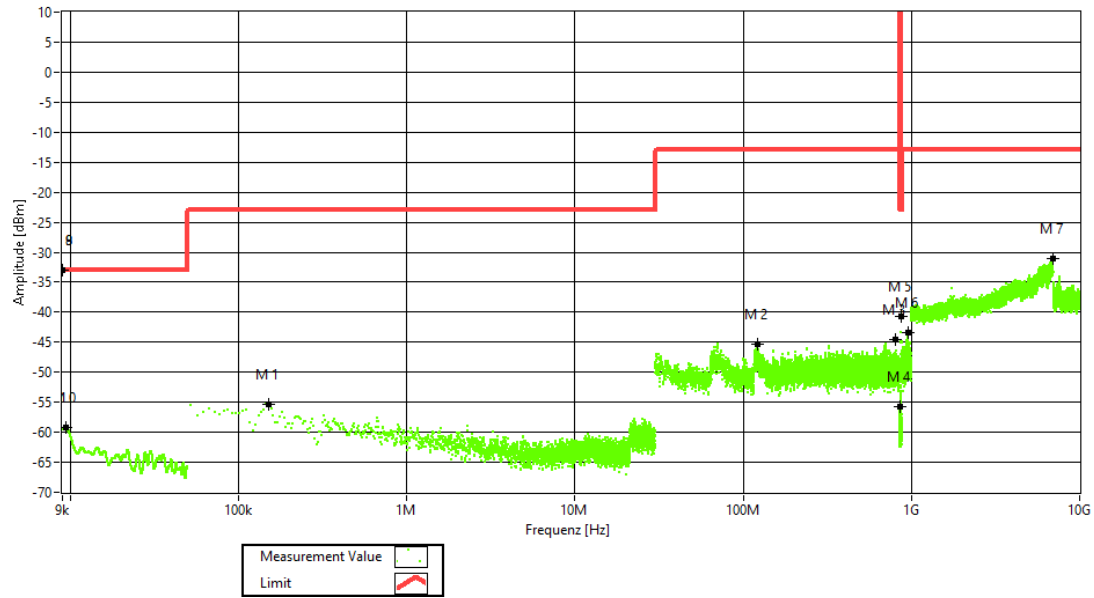

4.4.5 TEST EQUIPMENT USED

- Conducted



ECL-TA-20-006-V01.00

TA tests on Andrew CAP MX AC 6/7E/80-
85/17E/19/23/25T

4.5 OUT-OF-BAND EMISSION LIMITS

Standard FCC Part § 2.1051, § 27.53

The test was performed according to:
ANSI C63.26, KDB 935210 D05 v01r04: 3.6

Test date: 2020-07-22

Environmental conditions: 25 ° C; 40 % r. F.

Test engineer: Thomas Hufnagel

4.5.1 TEST DESCRIPTION

This test case is intended to demonstrate compliance to the out-of-band emission limit for industrial signal boosters. The limits itself come from the applicable rule part for each operating band per FCC § 2.1051, FCC § 27.53, RSS-GEN with subpart 6.13 and RSS-130 with subpart 4.7.

The EUT was connected to the test setup according to the following diagram:

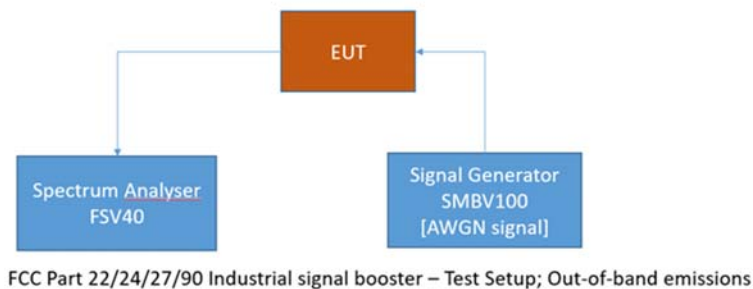

The attenuation of the measuring and stimulus path are known for each measured frequency and are considered.

The Spectrum Analyser settings can be directly found in the measurement diagrams.



ECL-TA-20-006-V01.00

TA tests on Andrew CAP MX AC 6/7E/80-85/17E/19/23/25T

4.5.2 TEST REQUIREMENTS/LIMITS

Abstract § 2.1051 from FCC:

FCC Part 2.1051; Measurement required: Spurious emissions at antenna terminal:

The radio frequency voltage or powers generated within the equipment and appearing on a spurious frequency shall be checked at the equipment output terminals when properly loaded with a suitable artificial antenna. Curves or equivalent data shall show the magnitude of each harmonic and other spurious emission that can be detected when the equipment is operated under the conditions specified in § 2.1049 as appropriate. The magnitude of spurious emissions which are attenuated more than 20 dB below the permissible value need not be specified.

Abstract § 90.691 FCC:

§ 90.691 Emission mask requirements for EA-based systems.

(a) Out-of-band emission requirement shall apply only to the "outer" channels included in an EA license and to spectrum adjacent to interior channels used by incumbent licensees. The emission limits are as follows:

(2) For any frequency removed from the EA licensee's frequency block greater than 37.5 kHz, the power of any emission shall be attenuated below the transmitter power (P) in watts by at least $43 + 10\log_{10}(P)$ decibels or 80 decibels, whichever is the lesser attenuation, where f is the frequency removed from the center of the outer channel in the block in kilohertz and where f is greater than 37.5 kHz.

Abstract RSS-119 5.8.9.2 from ISED:

5.8.9.2 Out-of-Band Emission Limit

On any frequency outside of the ranges specified in the ACP tables 13 to 16, the power of any emission shall be attenuated below the mean output power P (dBW) by at least $43 + 10\log_{10}(p)$, measured in a 100 kHz bandwidth for frequencies less than or equal to 1 GHz, and in a 1 MHz bandwidth for frequencies greater than 1 GHz.



ECL-TA-20-006-V01.00

TA tests on Andrew CAP MX AC 6/7E/80-85/17E/19/23/25T

4.5.3 TEST PROTOCOL

CELL 800, downlink, Number of input signals = 1							
Signal Type	Input Power	Band Edge	Signal Frequency [MHz]	Input Power [dBm]	Maximum Out-of-band Power [dBm]	Limit Out-of-band Power [dBm]	Margin to Limit [dB]
Wideband	-0.3 dB < AGC	upper	866.50	-1.9	-32.1	-13.0	19.1
Wideband	3 dB > AGC	upper	866.50	1.4	-32.2	-13.0	19.2
Narrowband	-0.3 dB < AGC	upper	868.80	-1.9	-24.5	-13.0	11.5
Narrowband	3 dB > AGC	upper	868.80	1.4	-25.1	-13.0	12.1
Wideband	-0.3 dB < AGC	lower	864.50	-1.9	-32.6	-13.0	19.6
Wideband	3 dB > AGC	lower	864.50	1.4	-32.4	-13.0	19.4
Narrowband	-0.3 dB < AGC	lower	862.20	-2.1	-24.9	-13.0	11.9
Narrowband	3 dB > AGC	lower	862.20	1.2	-25.4	-13.0	12.4

CELL 800, downlink, Number of input signals = 2								
Signal Type	Input Power	Band Edge	Signal Frequency f1 [MHz]	Signal Frequency f2 [MHz]	Input Power [dBm]	Maximum Out-of-band Power [dBm]	Limit Out-of-band Power [dBm]	Margin to Limit [dB]
WB	-0.3 dB < AGC	upper	866.50	864.00	-1.9	-32.1	-13.0	19.1
WB	3 dB > AGC	upper	866.50	864.00	1.4	-32.2	-13.0	19.2
NB	-0.3 dB < AGC	upper	868.80	868.60	-1.9	-24.5	-13.0	11.5
NB	3 dB > AGC	upper	868.80	868.60	1.4	-25.1	-13.0	12.1
WB	-0.3 dB < AGC	lower	864.50	867.00	-1.9	-32.6	-13.0	19.6
WB	3 dB > AGC	lower	864.50	867.00	1.4	-32.4	-13.0	19.4
NB	-0.3 dB < AGC	lower	862.20	862.40	-2.1	-24.9	-13.0	11.9
NB	3 dB > AGC	lower	862.20	862.40	1.2	-25.4	-13.0	12.4

Remark: Please see next sub-clause for the measurement plot.

Explanations concerning table with two input signals:

“WB” means Wideband.
 “NB” means Narrowband.



BUREAU
VERITAS

ECL-TA-20-006-V01.00

TA tests on Andrew CAP MX AC 6/7E/80-
85/17E/19/23/25T

4.5.4 MEASUREMENT PLOT (SHOWING THE HIGHEST VALUE, "WORST CASE")

Band: CELL 800; Frequency: 862.0000 MHz to 869.0000 MHz; Band Edge: upper; Mod: AWGN;
Input Power = 0.3 dB < AGC; Number of signals 1

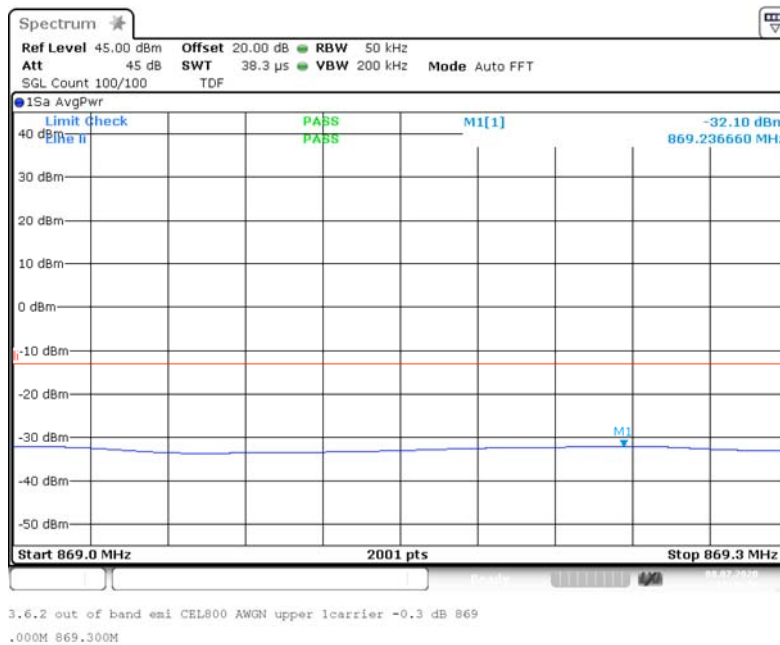

Band: CELL 800; Frequency: 862.0000 MHz to 869.0000 MHz; Band Edge: upper; Mod: AWGN;
Input Power = 3 dB > AGC; Number of signals 1

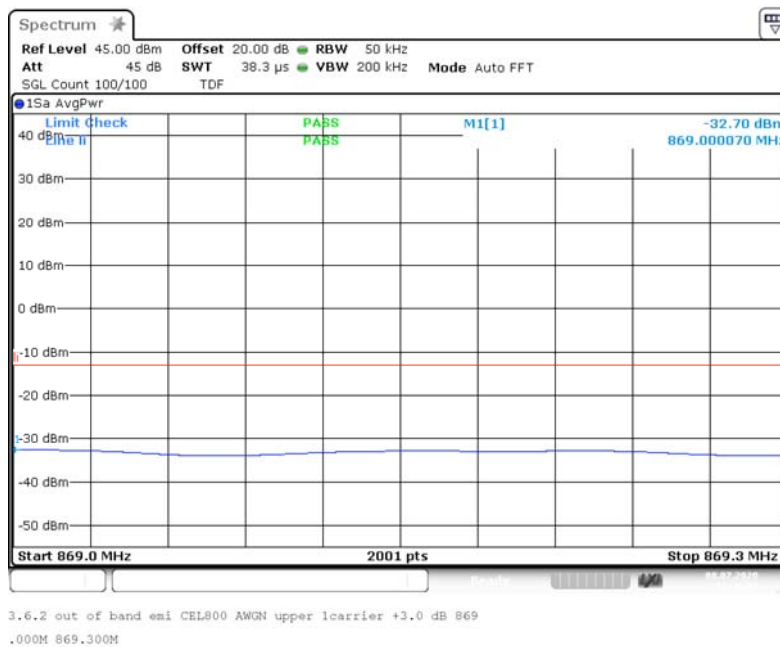



BUREAU
VERITAS

ECL-TA-20-006-V01.00

TA tests on Andrew CAP MX AC 6/7E/80-85/17E/19/23/25T

Band: CELL 800; Frequency: 862.0000 MHz to 869.0000 MHz; Band Edge: upper; Mod: GSM; Input Power = 0.3 dB < AGC; Number of signals 1

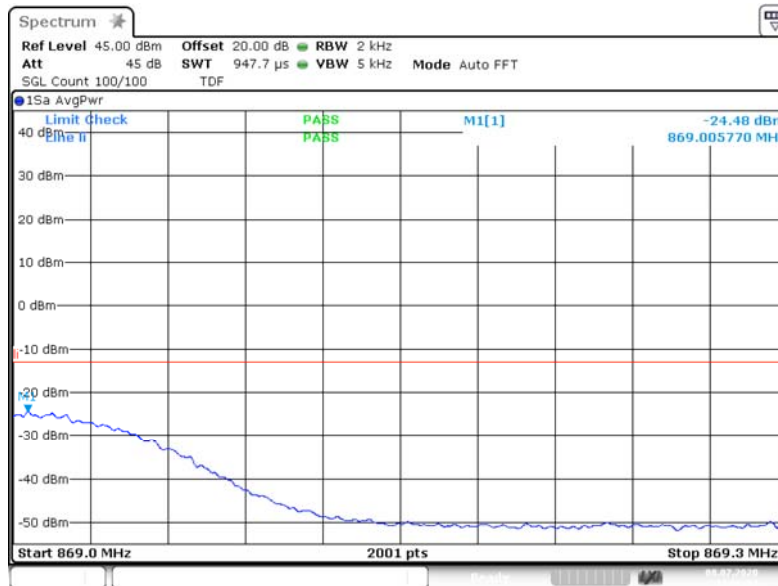

3.6.2 out of band emi CEL800 GSM upper 1carrier -0.3 dB 869.
000M 869.300M

Band: CELL 800; Frequency: 862.0000 MHz to 869.0000 MHz; Band Edge: upper; Mod: GSM; Input Power = 3 dB > AGC; Number of signals 1

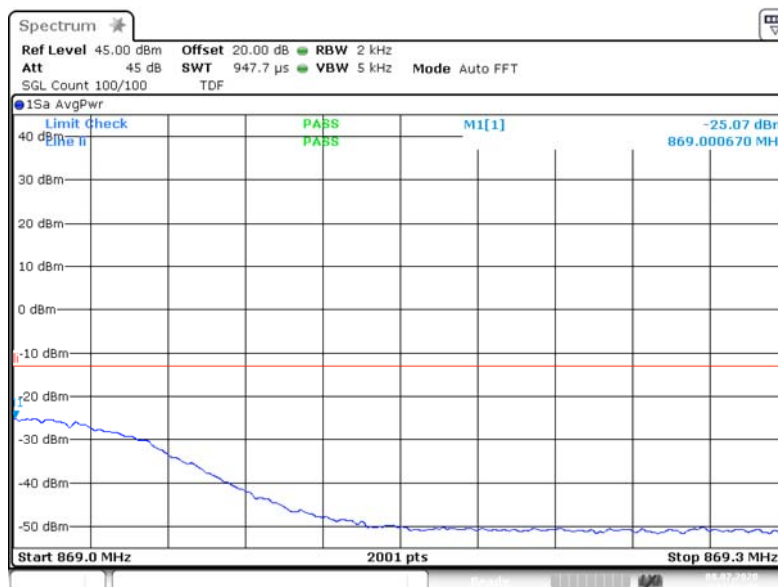

3.6.2 out of band emi CEL800 GSM upper 1carrier +3.0 dB 869.
000M 869.300M



BUREAU
VERITAS

ECL-TA-20-006-V01.00

TA tests on Andrew CAP MX AC 6/7E/80-85/17E/19/23/25T

Band: CELL 800; Frequency: 862.0000 MHz to 869.0000 MHz; Band Edge: lower; Mod: AWGN;
Input Power = 0.3 dB < AGC; Number of signals 1

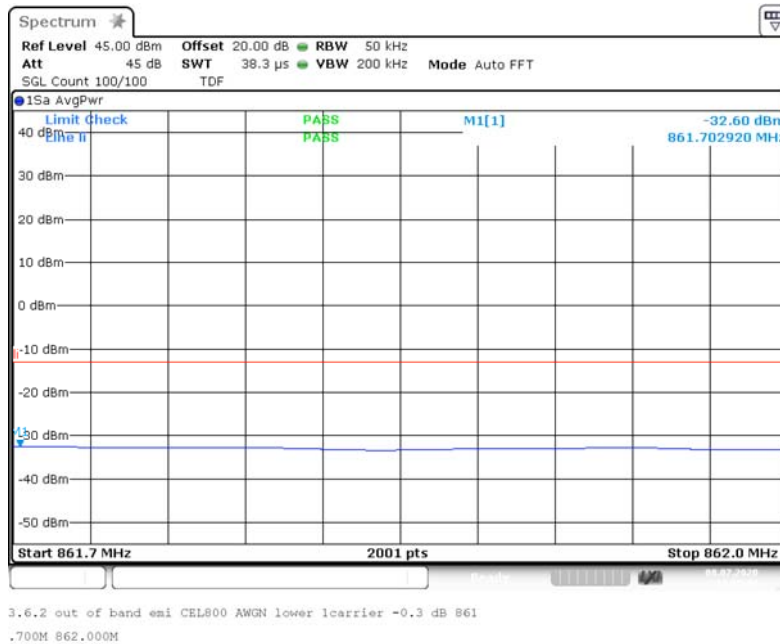

Band: CELL 800; Frequency: 862.0000 MHz to 869.0000 MHz; Band Edge: lower; Mod: AWGN;
Input Power = 3 dB > AGC; Number of signals 1

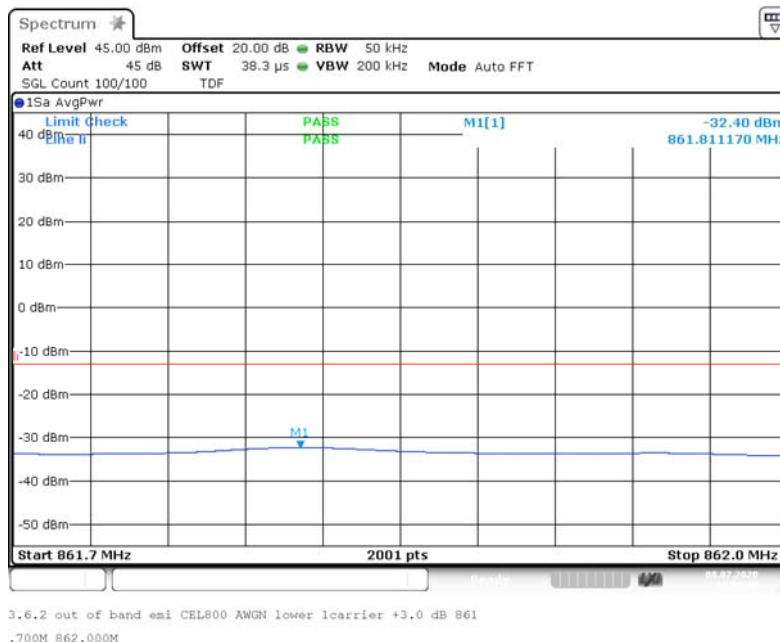



BUREAU
VERITAS

ECL-TA-20-006-V01.00

TA tests on Andrew CAP MX AC 6/7E/80-85/17E/19/23/25T

Band: CELL 800; Frequency: 862.0000 MHz to 869.0000 MHz; Band Edge: lower; Mod: GSM; Input Power = 0.3 dB < AGC; Number of signals 1



3.6.2 out of band emi CEL800 GSM lower lcarrier -0.3 dB 861.
700M 862.000M

Band: CELL 800; Frequency: 862.0000 MHz to 869.0000 MHz; Band Edge: lower; Mod: GSM; Input Power = 3 dB > AGC; Number of signals 1

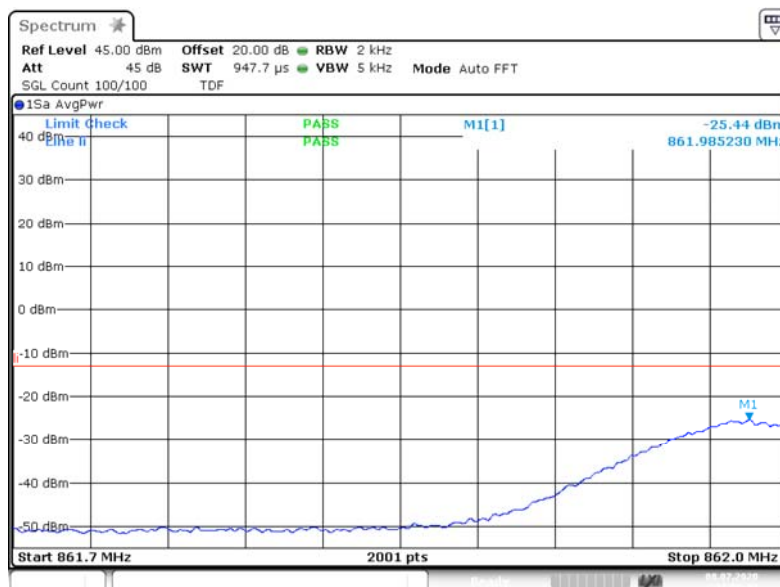

3.6.2 out of band emi CEL800 GSM lower lcarrier +3.0 dB 861.
700M 862.000M



BUREAU
VERITAS

ECL-TA-20-006-V01.00

TA tests on Andrew CAP MX AC 6/7E/80-85/17E/19/23/25T

Band: CELL 800; Frequency: 862.0000 MHz to 869.0000 MHz; Band Edge: upper; Mod: AWGN;
Input Power = 0.3 dB < AGC; Number of signals 2

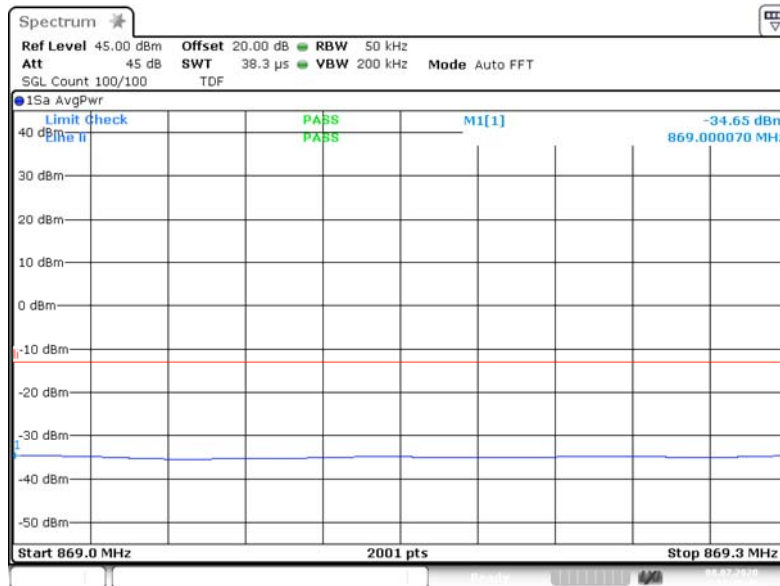

3.6.2 out of band emi CEL800 AWGN upper 2carriers -0.3 dB 86
9.000M 869.300M

Band: CELL 800; Frequency: 862.0000 MHz to 869.0000 MHz; Band Edge: upper; Mod: AWGN;
Input Power = 3 dB > AGC; Number of signals 2

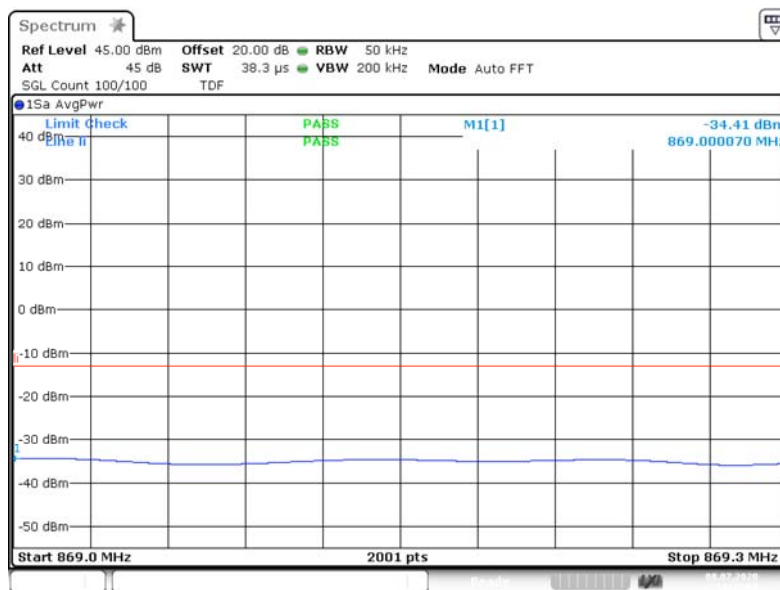

3.6.2 out of band emi CEL800 AWGN upper 2carriers +3.0 dB 86
9.000M 869.300M



**BUREAU
VERITAS**

ECL-TA-20-006-V01.00

TA tests on Andrew CAP MX AC 6/7E/80-85/17E/19/23/25T

Band: CELL 800; Frequency: 862.0000 MHz to 869.0000 MHz; Band Edge: upper; Mod: GSM; Input Power = 0.3 dB < AGC; Number of signals 2



3.6.2 out of band emi CEL800 GSM upper 2carriers -0.3 dB 869
.000M 869.300M

Band: CELL 800; Frequency: 862.0000 MHz to 869.0000 MHz; Band Edge: upper; Mod: GSM; Input Power = 3 dB > AGC; Number of signals 2



3.6.2 out of band emi CEL800 GSM upper 2carriers +3.0 dB 869
.000M 869.300M



BUREAU
VERITAS

ECL-TA-20-006-V01.00

TA tests on Andrew CAP MX AC 6/7E/80-85/17E/19/23/25T

Band: CELL 800; Frequency: 862.0000 MHz to 869.0000 MHz; Band Edge: lower; Mod: AWGN;
Input Power = 0.3 dB < AGC; Number of signals 2

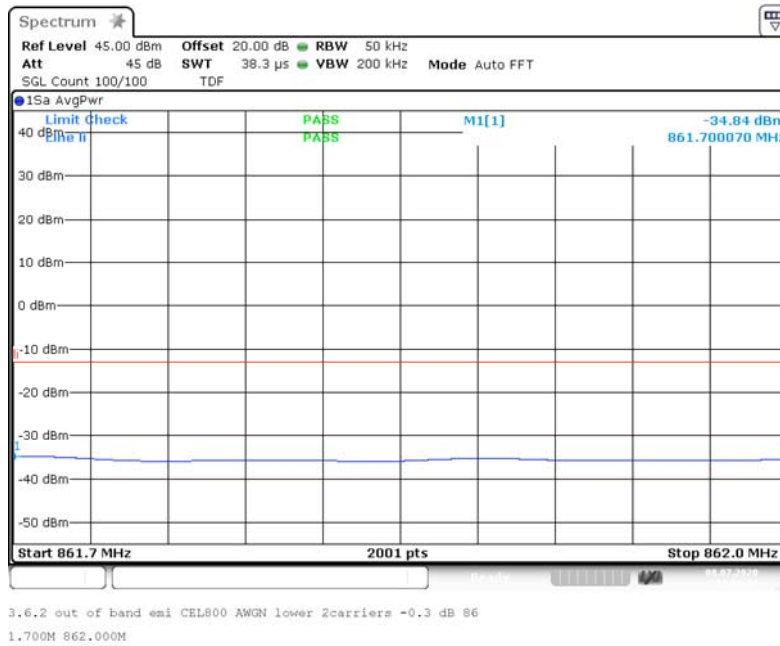

Band: CELL 800; Frequency: 862.0000 MHz to 869.0000 MHz; Band Edge: lower; Mod: AWGN;
Input Power = 3 dB > AGC; Number of signals 2

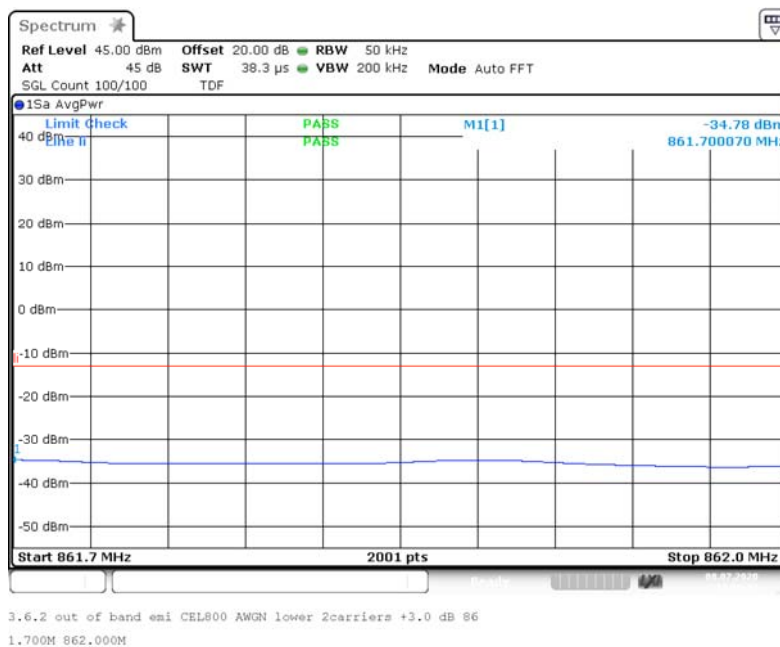



**BUREAU
VERITAS**

ECL-TA-20-006-V01.00

TA tests on Andrew CAP MX AC 6/7E/80-85/17E/19/23/25T

Band: CELL 800; Frequency: 862.0000 MHz to 869.0000 MHz; Band Edge: lower; Mod: GSM; Input Power = 0.3 dB < AGC; Number of signals 2

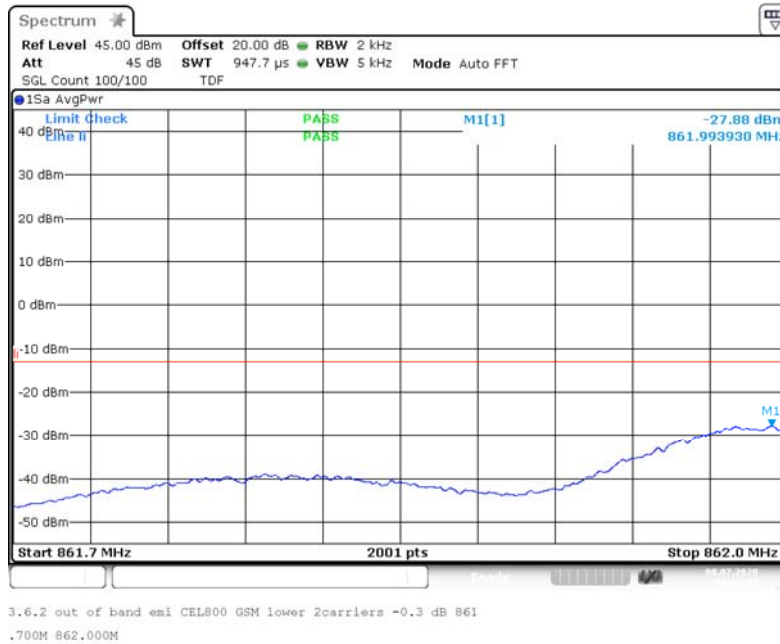

Band: CELL 800; Frequency: 862.0000 MHz to 869.0000 MHz; Band Edge: lower; Mod: GSM; Input Power = 3 dB > AGC; Number of signals 2

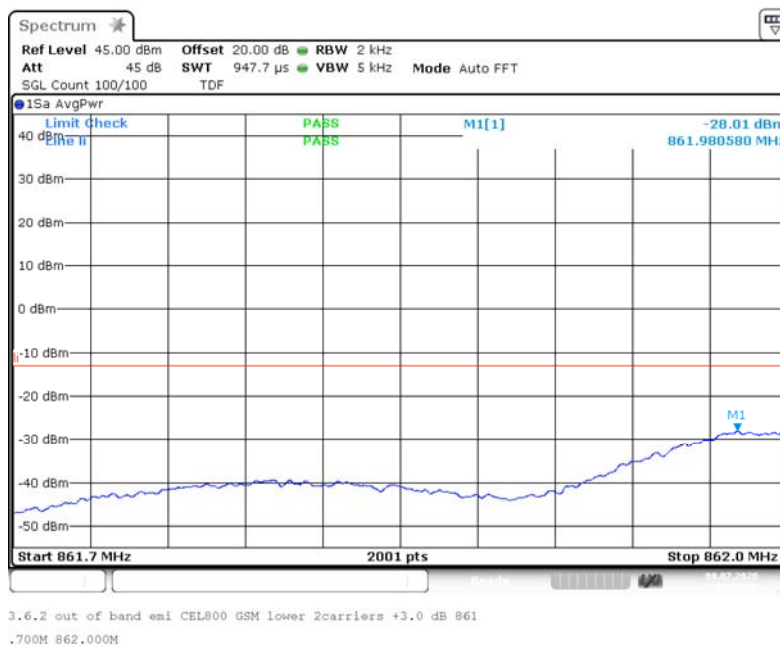

4.5.5 TEST EQUIPMENT USED

- Conducted



ECL-TA-20-006-V01.00

TA tests on Andrew CAP MX AC 6/7E/80-
85/17E/19/23/25T

4.6 OUT-OF-BAND REJECTION

Standard FCC Part 27

The test was performed according to:
ANSI C63.26; KDB 935210 D05

Test date: 2020-07-22

Environmental conditions: 25 ° C; 40 % r. F.

Test engineer: Thomas Hufnagel

4.6.1 TEST DESCRIPTION

This test case is intended to demonstrate compliance to the out-of-band rejection test case for industrial signal boosters.

The EUT was connected to the test setup according to the following diagram:

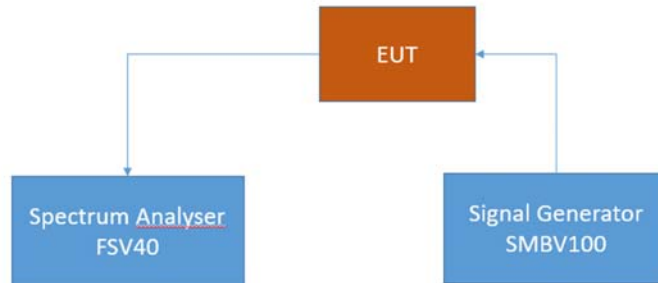

FCC Part 22/24/27/90 Industrial signal booster – Test Setup; Out-of-band rejection

The attenuation of the measuring and stimulus path are known for each measured frequency and are considered.

The Spectrum Analyzer settings can be directly found in the measurement diagrams.

4.6.2 TEST REQUIREMENTS/LIMITS

For this test case exists no applicable limit



ECL-TA-20-006-V01.00

TA tests on Andrew CAP MX AC 6/7E/80-85/17E/19/23/25T

4.6.3 TEST PROTOCOL

CELL 800, downlink				
Highest Power Frequency [MHz]	Output Power [dBm]	Lower Highest Power -20 dB Frequency [MHz]	Upper Highest Power -20 dB Frequency [MHz]	20 dB Bandwidth [MHz]
867.50	23.09	861.6903	869.3098	7.6195

Remark: Please see next sub-clause for the measurement plot.

4.6.4 MEASUREMENT PLOT (SHOWING THE HIGHEST VALUE, "WORST CASE")

Frequency Band = CELL 800, Direction = RF downlink

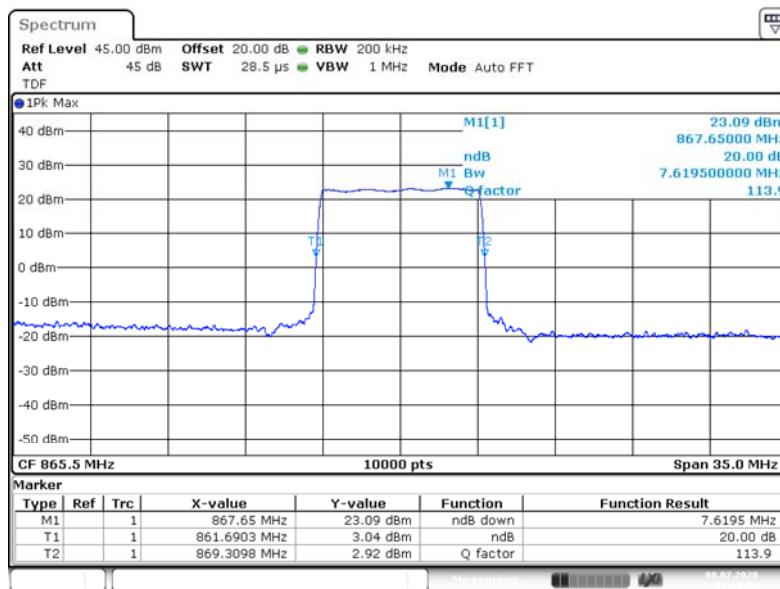

3.3 Out of band rejection CEL800 865.50000M
_20dB

4.6.5 TEST EQUIPMENT USED

- Conducted



ECL-TA-20-006-V01.00

TA tests on Andrew CAP MX AC 6/7E/80-
85/17E/19/23/25T

4.7 NOISE AND NOISE FIGURE

Standard FCC Part 90, § 90.219,

The test was performed according to:
ANSI C63.26

Test date: 2020-10-09

Environmental conditions: 23 ° C; 46 % r. F.

Test engineer: Thomas Gerngroß

4.7.1 TEST DESCRIPTION

This test case is intended to demonstrate compliance to noise limit for industrial signal boosters. per FCC § 90.219 and RSS-131 with subpartd 6.3 and 6.4.

The EUT was connected to the test setup according to the following diagram:



FCC Part 22/24/27/90 Industrial signal booster – Test Setup; Noise

The attenuation of the measuring and stimulus path are known for each measured frequency and are considered.

The Spectrum Analyser settings can be directly found in the measurement diagrams.



ECL-TA-20-006-V01.00

TA tests on Andrew CAP MX AC 6/7E/80-
85/17E/19/23/25T

4.7.2 TEST REQUIREMENTS / LIMITS

Abstract § 90.219 from FCC

§ 90.219 – Use of signal boosters

(d)(6)

Good engineering practice must be used in regard to the radiation of intermodulation products and noise, such that interference to licensed communications systems is avoided. In the event of harmful interference caused by any given deployment, the FCC may require additional attenuation or filtering of the emissions and/or noise from signal boosters or signal booster systems, as necessary to eliminate the interference.

(d) (6) (i)

In general, the ERP of intermodulation products should not exceed -30 dBm in 10 kHz measurement bandwidth.

(d) (6) (ii)

In general, the ERP of noise within the passband should not exceed -43 dBm in 10 kHz measurement bandwidth.

(d) (6) (iii)

In general, the ERP of noise on spectrum more than 1 MHz outside of the passband should not exceed -70 dBm in a 10 kHz measurement bandwidth.

(e)(2)

The noise figure of a signal booster must not exceed 9 dB in either direction.

Abstract RSS-131:

RSS131; 6.3 Intermodulation

The effective radiated power (ERP) of intermodulation products should not exceed -30 dBm in a 10 kHz measurement bandwidth.

RSS-131; 6.4 Noise

The ERP of noise within the passband should not exceed -43 dBm in a 10 kHz measurement bandwidth.

The ERP of noise in spectrum more than 1 MHz outside of the passband should not exceed -70 dBm in a 10 kHz measurement bandwidth.

The noise figure of a zone enhancer shall not exceed 9 dB in either direction.



ECL-TA-20-006-V01.00

TA tests on Andrew CAP MX AC 6/7E/80-
85/17E/19/23/25T

Customer declaration concerning the noise figure:

- The noise power at the output of a RF 2-port is dependent on noise figure NF and gain G; i.e a high NF does not mean necessarily high noise power at the output;
 - FCC limits the noise figure NF of a signal booster to max. 9 dB (also in DL)
 - FCC defines: "signal boosters" as all manners of amplifiers, repeaters, boosters, distributed antenna systems and in-building radiation that serve to amplify signals between a device and a wireless network";
 - Noise figure NF is a useful and common manner for the characterization of a noisy RF 2-port;
- The DUT is **attenuating** till the position after the D/A converter; only from the position after the D/A converter to the output of the CAP-L the DUT is **amplifying** (this chain of RF components is the only complete and cohesive chain with predominantly amplifying stages (including the output port) (output port shall be included, since noise power at the output is of interest));
- above mentioned FCC definition of signal boosters ("serve to amplify signals") + definition of "noise figure" for RF 2-ports entail to set the reference planes for determining NF of the DL at the position after the D/A converter and the output of the CAP-L;
This means that NF of the DUT in DL has to be determined between these two reference planes (NF of the amplification stages between output of the D/A converter and output of the CAP-L);

This noise figure is below 9 dB!

To verify this fact, it would be necessary to carry out a second NF measurement with a reference CAP-L, containing only the D/A converter.
Knowing both noise figures (complete DUT + reference CAP-L), NF of the required amplification stages can be calculated.

Another way to get the NF of the required amplification stages, is to accept line up calculation. This should be acceptable, since NF of the amplification stages is sufficiently lower than 9 dB.

In addition to that, the output noise level, which is crucial, was measured and is significant below the limit.



ECL-TA-20-006-V01.00

TA tests on Andrew CAP MX AC 6/7E/80-85/17E/19/23/25T

4.7.3 TEST PROTOCOL OF NOISE

Band CELL 800 (862 MHz to 869 MHz), downlink		
Test step	Limit	Result
Passband	≤ -43 dBm	Passed
Out of passband	≤ -70 dBm	Passed
Remark	At a frequency at about 878 MHz (see plot), in the out of passband range, a signal level of -43.6 dBm is measured. However, this is no noise but an intermodulation product. The border line of intermodulation products is at -30 dBm.	

4.7.4 MEASUREMENT PLOT

Frequency Band = CELL 800, Direction = RF downlink, Test Step = passband

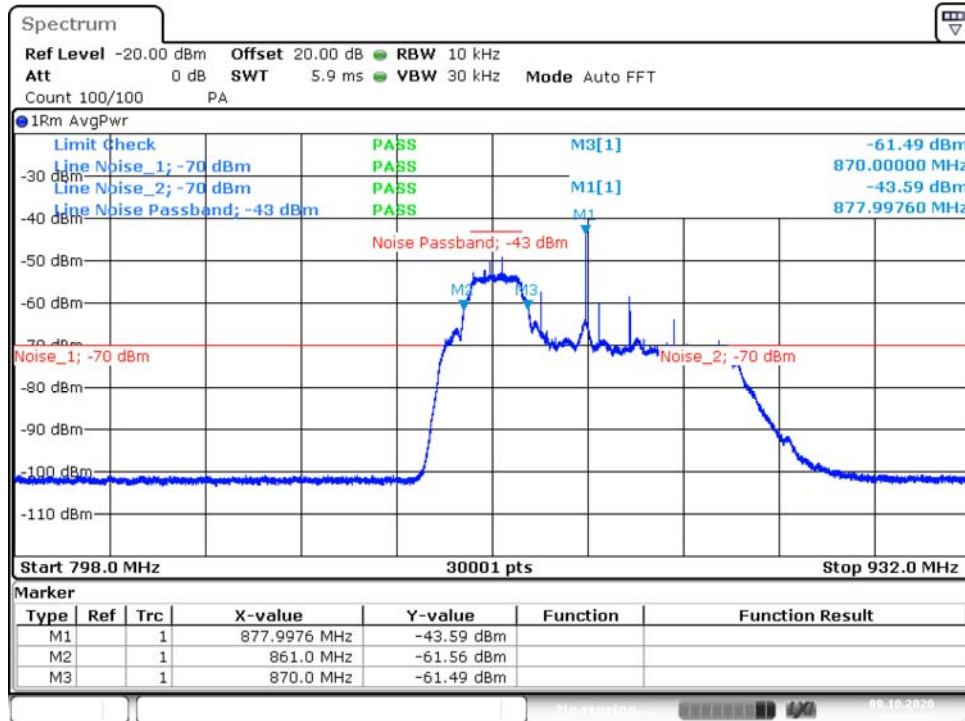

Noise Downlink, Band CELL 800

Remarks:

The markers M2 and M3 show the 1 MHz distance points from the band edge frequencies. M1 shows the highest intermodulation peak value.

The peaks in the curve are intermodulation products and the curve from above 869 MHz of the band CELL 800 to about 894 MHz of the band CELL 800 is the suppressed line of the neighbour band.

ECL-TA-20-006-V01.00

TA tests on Andrew CAP MX AC 6/7E/80-85/17E/19/23/25T

4.8 FIELD STRENGTH OF SPURIOUS RADIATION

Standard FCC Part 27, § 24.53

The test was performed according to:
ANSI C63.26

Test date: 2020-09-09

Environmental conditions: 23 ° C; 46 % r. F.

Test engineer: Thomas Hufnagel

4.8.1 TEST DESCRIPTION

This test case is intended to demonstrate compliance to the applicable radiated spurious emission measurements per § 2.1053

The EUT was connected to the test setup according to the following diagram:

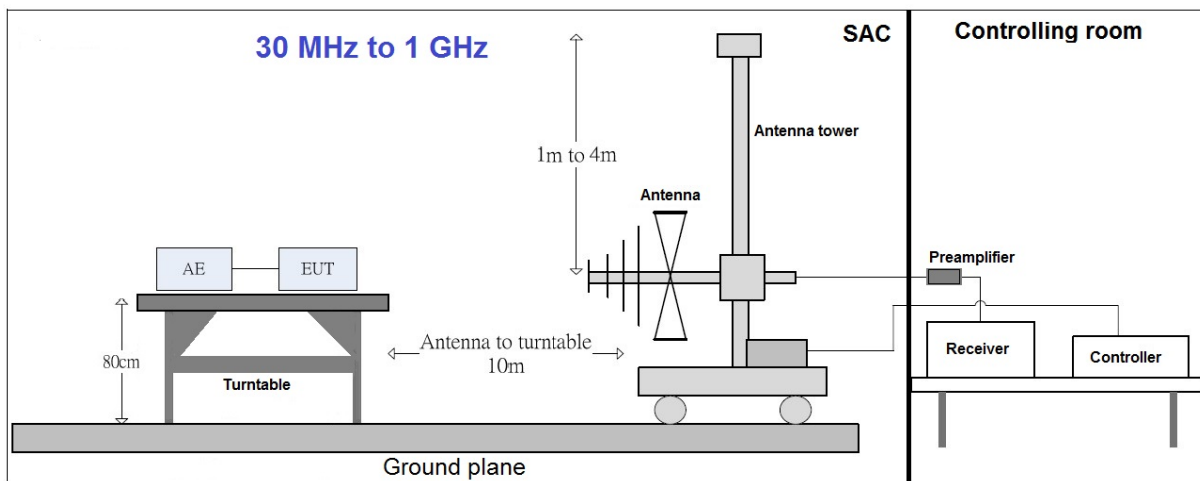

ECL-TA-20-006-V01.00

TA tests on Andrew CAP MX AC 6/7E/80-85/17E/19/23/25T

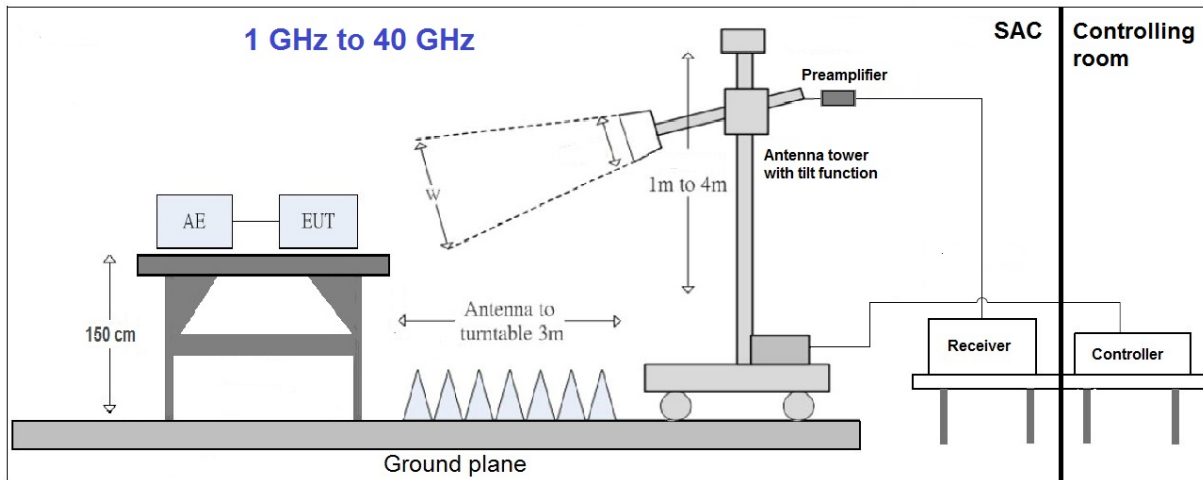

The test set-up was made in accordance to the general provisions of ANSI C63.4 in a typical installation configuration. The Equipment Under Test (EUT) was set up on a non-conductive table 1.5 x 1.5 m² in the semi-anechoic chamber, 0.8 meter above the ground or floor-standing arrangement shall be placed on the horizontal ground reference plane.. The influence of the EUT support table that is used between 30–1000 MHz was evaluated. For the initial measurements, the receiving antenna is varied from 1-4 meter height and is changed in the vertical plane from vertical to horizontal polarization at each frequency. The highest emissions between 30 MHz to 1000 MHz were analyzed in details by operating the spectrum analyzer and/or EMI receiver in quasi-peak mode to determine the precise amplitude of the emissions.

The measurement procedure is implemented into the EMI test software BAT EMC from NEXIO. Exploratory tests are performed at 3 orthogonal axes to determine the worst-case orientation of a body-worn or handheld EUT. The final test on all kind of EUTs is also performed at 3 axes. A pre-check is performed while the EUT is powered by a DC power source. ?

1. Measurement above 30 MHz and up to 1 GHz

Step 1: Preliminary scan

This is a preliminary test to identify the highest amplitudes relative to the limit.

Settings for step 1:

- Antenna distance: 10 m
- Detector: Peak-Maxhold/RMS (FFT-based)
- Frequency range: 30 – 1000 MHz
- Frequency steps: 30 kHz
- IF-Bandwidth: 120 kHz
- Measuring time/Frequency step: 5 ms
- Turntable angle range: -180° to 180°
- Turntable step size: 30°
- Height variation range: 1 – 4 m
- Height variation step size: 1 m
- Polarisation: Horizontal + Vertical

Intention of this step is, to determine the radiated EMI-profile of the EUT. Afterwards the relevant emissions for the final measurement are identified.



ECL-TA-20-006-V01.00

TA tests on Andrew CAP MX AC 6/7E/80-
85/17E/19/23/25T

Step 2: Adjustment measurement

In this step the accuracy of the turntable azimuth and antenna height will be improved. This is necessary to find out the maximum value of every frequency.

For each frequency, which was determined the turntable azimuth and antenna height will be adjusted. The turntable azimuth will slowly vary by $\pm 45^\circ$ around this value. During this action, the value of emission is continuously measured. The turntable azimuth at the highest emission will be recorded and adjusted. In this position, the antenna height will also slowly vary by ± 100 cm around the antenna height determined. During this action, the value of emission is also continuously measured. The antenna height of the highest emission will also be recorded and adjusted.

- Detector: Peak – Maxhold; RMS
- Measured frequencies: in step 1 determined frequencies
- IF – Bandwidth: 120 kHz
- Measuring time: 100 ms
- Turntable angle range: $\pm 30^\circ$ around the determined value
- Antenna Polarisation: max. value determined in step 1

Step 3: Final measurement with QP detector

With the settings determined in step 3, the final measurement will be performed:

EMI receiver settings for step 4:

- Detector: Quasi-Peak (< 1 GHz); RMS; Peak
- Measured frequencies: in step 1 determined frequencies
- IF – Bandwidth: 120 kHz
- Measuring time: 1 s

After the measurement a plot will be generated which contains a diagram with the results of the preliminary scan and a chart with the frequencies and values of the results of the final measurement.

3. Measurement above 1 GHz

The following modifications apply to the measurement procedure for the frequency range above 1 GHz:

Step 1:

The Equipment Under Test (EUT) was set up on a non-conductive support at 1.5 m height in the semi-anechoic chamber. Absorbers are placed around and between the turn table and the antenna tower.

All steps were performed with one height (1.5 m) of the receiving antenna only.

The EUT is turned during the preliminary measurement across the elevation axis, with a step size of 30° .

The turn table step size (azimuth angle) for the preliminary measurement is 15° .

Step 2:

The maximum RFI field strength was determined during the measurement by rotating the turntable (± 180 degrees) and varying the height of the receive antenna ($h = 1 \dots 4$ m) with a additional tilt function of the antenna. The turn table azimuth will slowly vary by $\pm 15^\circ$.

EMI receiver settings (for all steps):

- Detector: Peak, Average
- IF Bandwidth = 1 MHz



ECL-TA-20-006-V01.00

TA tests on Andrew CAP MX AC 6/7E/80-
85/17E/19/23/25T

Step 3:

Spectrum analyser settings for step 3:

- Detector: Peak/Average
- Measured frequencies: in step 1 determined frequencies
- IF – Bandwidth: 1 MHz
- Measuring time: 1 s

4.8.2 TEST REQUIREMENTS/LIMITS

Abstract from FCC Part § 2.1053:

FCC Part 2.1053; Measurement required: Field strength of spurious radiation:

Measurements shall be made to detect spurious emissions that may be radiated directly from the cabinet, control circuits, power leads, or intermediate circuit elements under normal conditions of installation and operation. Curves or equivalent data shall be supplied showing the magnitude of each harmonic and other spurious emission. For this test, single sideband, independent sideband, and controlled carrier transmitters shall be modulated under the conditions specified in paragraph (c) of § 2.1049, as appropriate.

Abstract § 90.691 FCC:

§ 90.691 Emission mask requirements for EA-based systems.

(a) Out-of-band emission requirement shall apply only to the “outer” channels included in an EA license and to spectrum adjacent to interior channels used by incumbent licensees. The emission limits are as follows:

(2) For any frequency removed from the EA licensee's frequency block greater than 37.5 kHz, the power of any emission shall be attenuated below the transmitter power (P) in watts by at least $43 + 10\log_{10}(P)$ decibels or 80 decibels, whichever is the lesser attenuation, where f is the frequency removed from the center of the outer channel in the block in kilohertz and where f is greater than 37.5 kHz.

Abstract RSS-119 5.8.9.2 from ISED:

5.8.9.2 Out-of-Band Emission Limit

On any frequency outside of the ranges specified in the ACP tables 13 to 16, the power of any emission shall be attenuated below the mean output power P (dBW) by at least $43 + 10\log_{10}(p)$, measured in a 100 kHz bandwidth for frequencies less than or equal to 1 GHz, and in a 1 MHz bandwidth for frequencies greater than 1 GHz.



ECL-TA-20-006-V01.00

TA tests on Andrew CAP MX AC 6/7E/80-85/17E/19/23/25T

4.8.3 TEST PROTOCOL

30 MHz to 1 GHz:

CELL 800, downlink;						
Spurious Freq. [MHz]	Spurious Level [dBm]	Pin (Sum Level) [dBm]	Detector	RBW [kHz]	Limit [dBm]	Margin to Limit [dB]
36,43	-66,4	-1.6	PEAK	120	-13.0	53,4
70,23	-56,1	-1.6	PEAK	120	-13.0	43,1
134,28	-65,9	-1.6	PEAK	120	-13.0	52,9
273,9	-53,3	-1.6	PEAK	120	-13.0	40,3
600,00	-62,7	-1.6	PEAK	120	-13.0	49,7
868,79	-54,9	-1.6	PEAK	120	-13.0	41,9

Above 1 GHz:

CELL 800, downlink;						
Spurious Freq. [MHz]	Spurious Level [dBm]	Pin (Sum Level) [dBm]	Detector	RBW [kHz]	Limit [dBm]	Margin to Limit [dB]
2849,62	-43,1	-1.6	PEAK	1000	-13,0	30,1
3542,43	-40,6	-1.6	PEAK	1000	-13,0	27,6
5253,1	-34,3	-1.6	PEAK	1000	-13,0	21,3
16290,75	-21,8	-1.6	PEAK	1000	-13,0	8,8
16746,87	-21,1	-1.6	PEAK	1000	-13,0	8,1
17806,4	-19,5	-1.6	PEAK	1000	-13,0	6,5

Remarks: Please see next sub-clause for the measurement plot.

Although usually a RMS detector is used for measurements in this cases a PEAK detector was used.

The limits are values for use of a RMS detector, but it is so, that the use of a PEAK detector results in readings with higher measured levels. Because the levels with the higher values with PEAK detector are in tolerance, the limits with a RMS detector are definitely also in tolerance.



BUREAU
VERITAS

ECL-TA-20-006-V01.00

TA tests on Andrew CAP MX AC 6/7E/80-85/17E/19/23/25T

4.8.4 MEASUREMENT PLOT (SHOWING THE HIGHEST VALUE, "WORST CASE")

Frequency Band = CELL 800, Test Frequency = low, Direction = RF downlink

30 MHz - 1 GHz

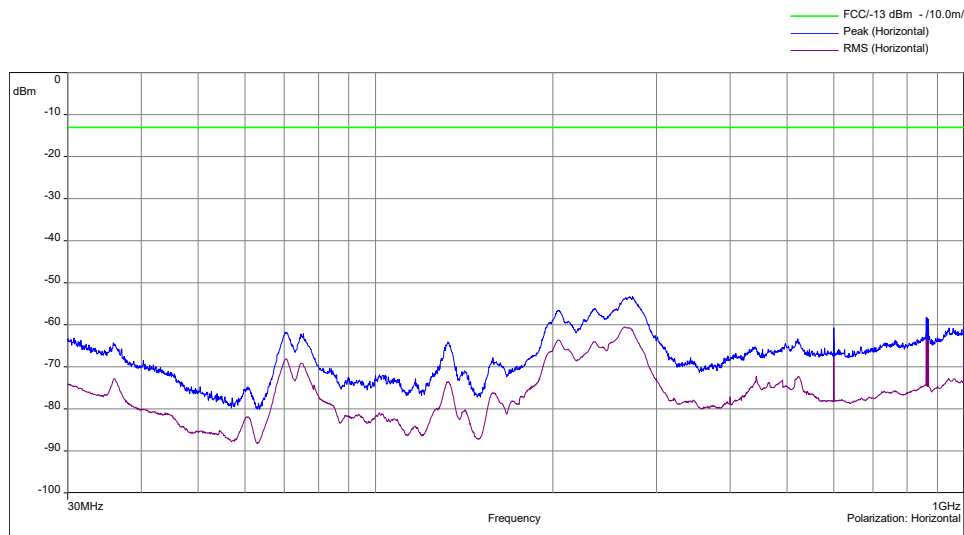
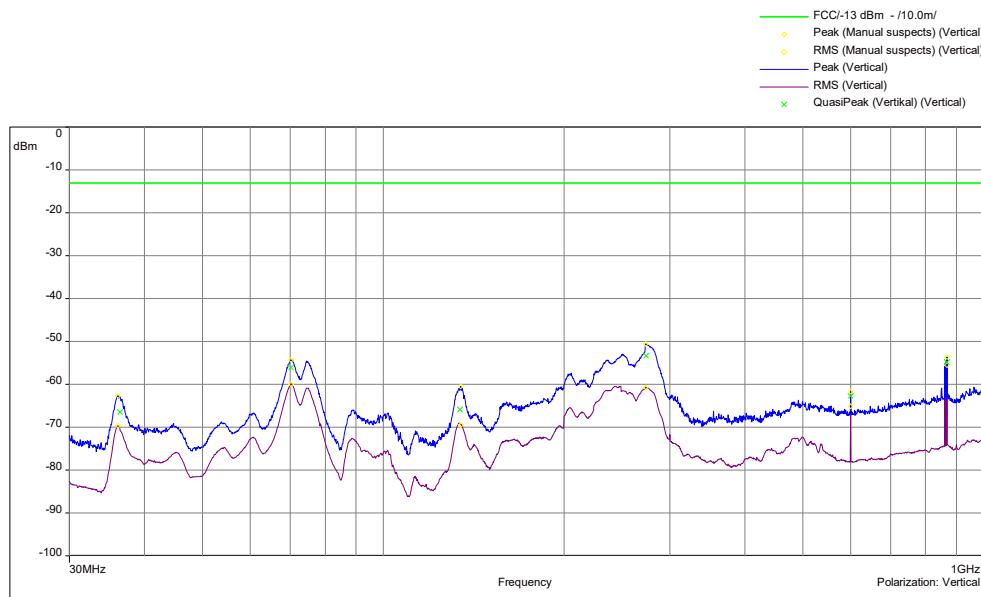



BUREAU
VERITAS

ECL-TA-20-006-V01.00

TA tests on Andrew CAP MX AC 6/7E/80-
85/17E/19/23/25T

1 GHz - 18 GHz

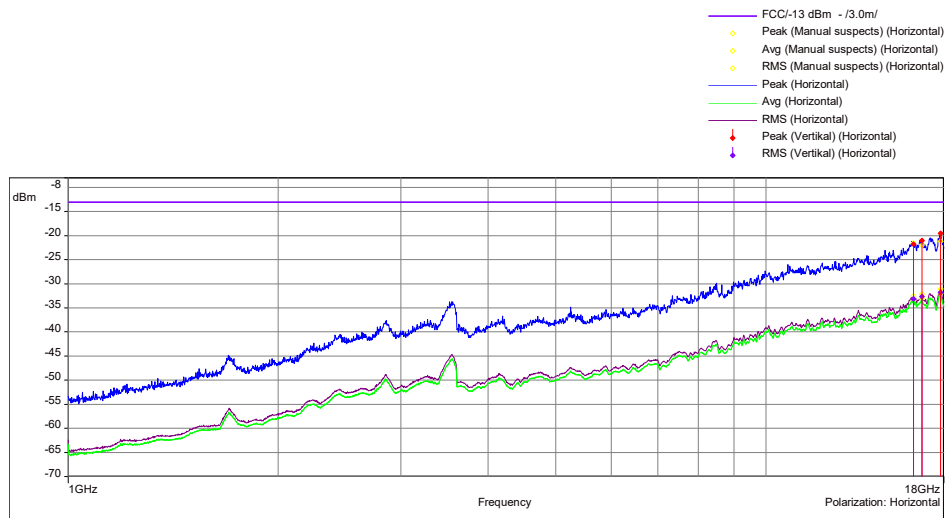
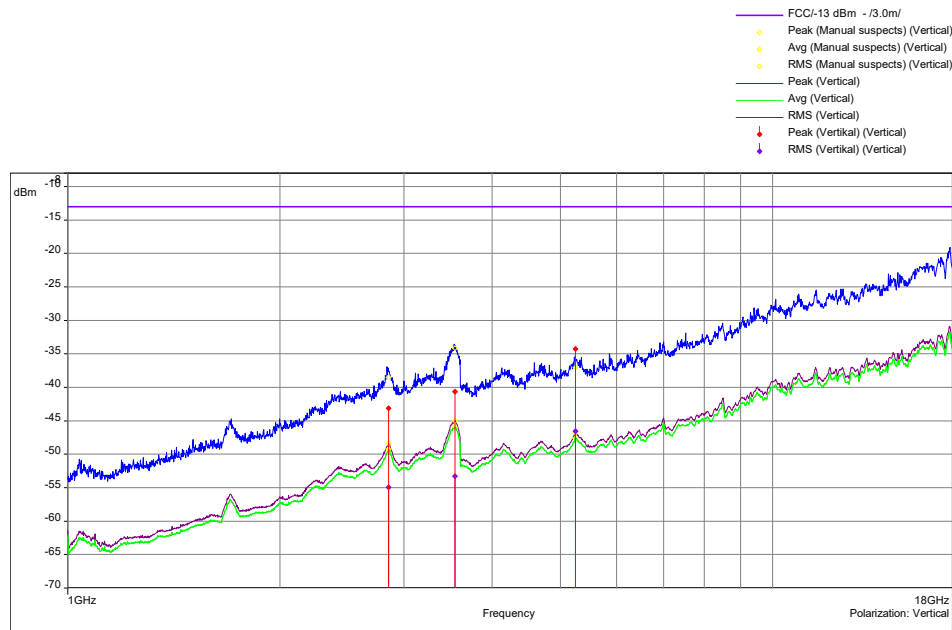



BUREAU
VERITAS

ECL-TA-20-006-V01.00

TA tests on Andrew CAP MX AC 6/7E/80-
85/17E/19/23/25T

4.8.5 FIELD STRENGTH CALCULATIONS

$$\mathbf{FS} = \mathbf{SA} + \mathbf{AF} + \mathbf{CL} + \mathbf{PA}$$

Where as:

- FS** = Field strength
- SA** = EMC test receiver reading
- AF** = Antenna factor
- CL** = Cable loss
- PA** = Preamplifier

4.8.6 TEST EQUIPMENT USED

- Radiated Emissions



ECL-TA-20-006-V01.00

TA tests on Andrew CAP MX AC 6/7E/80-
85/17E/19/23/25T

5 TEST EQUIPMENT

1 Conducted

Ref.No.	Type	Description	Manufacturer	Inventory no.	Last Calibration	Calibration Due
1.1	FSV40	Signal Analyzer 10 Hz - 40 GHz	Rohde & Schwarz	E2050	2019-10	2020-10
1.2	SMBV100A	Vector Signal Generator 9 kHz - 6 GHz	Rohde & Schwarz	G2089	2017-08/ 2020-08	2022-08
1.3	SMIQ	Vector Signal Generator 9 kHz - 3.3 GHz	Rohde & Schwarz	G1509	2018-10	2021-10
1.4	SMIQ	Vector Signal Generator 9 kHz - 3.3 GHz	Rohde & Schwarz	G1510	2018-10	2021-10
1.5	ESH3-Z5	Line Impedance Stabilisation Network (LISN) 150 Hz - 30 MHz	Rohde & Schwarz	K794	2019-02	2020-10
1.6	30.3015	ThermoHygro Datalogger	TFA	X 507	2018-08	2021-08
1.7	BAT-EMC	Software	Nexio	V3.17.0.26	---	---

2 Radiated Emissions

Ref.No.	Type	Description	Manufacturer	Inventory no.	Last Calibration	Calibration Due
2.1	ESU40	EMI test receiver 10 Hz - 40 GHz	Rohde & Schwarz	E2025	2018-10	2020-10
2.2	HFH2-Z2	Antenna 9 kHz - 30 MHz	Rohde & Schwarz	K549	2018-10	2020-10
2.3	CBL 6111C	Antenna 30 MHz - 1 GHz	Chase	K1026	2020-01	2021-01
2.4	HL 025	Antenna 1 GHz - 18 GHz	Rohde & Schwarz	K1114	2019-06	2021-06
2.5	MWH-1826/B	Antenna 18 GHz - 26.5 GHz	ARA Inc.	K1042	2018-11	2020-11
2.6	MWH-2640/B	Antenna 26 GHz - 40 GHz	ARA Inc.	K1043	2018-11	2020-11
2.7	AM1431	Pre amplifier 10 kHz - 1 GHz	Miteq	K1721	2019-10	2020-10
2.8	AFS4-00102000	Preamplifier 100 MHz - 20 GHz	Miteq	K817	2019-08	2021-08.
2.9	AFS4-00102000	Preamplifier 100 MHz - 20 GHz	Miteq	K838	2019-10	2020-10
2.10	JS43-1800-4000	Preamplifier 18 GHz - 40 GHz	Miteq	K1104	2019-05	2020-10
2.11	BAT-EMC	Software	Nexio	V3.17.0.26	---	---



ECL-TA-20-006-V01.00

TA tests on Andrew CAP MX AC 6/7E/80-85/17E/19/23/25T

6 ANTENNA FACTORS, CABLE LOSS AND SAMPLE CALCULATIONS

This chapter contains the antenna factors with their corresponding path loss of the used measurement path for all antennas.

6.1 ANTENNA CHASE CBL 6111C (30 MHZ – 1 GHZ)

(d = 10 m)

Frequency	AF Horizontal R&S CBL 6111C	AF Vertikal R&S CBL 6111C	Corr.
30	47.9	38.1	-38.1
50	34.4	26.4	-38.0
100	31.6	32.8	-38.0
150	33.7	33.9	-37.9
200	30.3	32.8	-37.7
250	33.6	36.5	-37.5
300	34.5	36.8	-37.1
350	36.3	37.2	-37.0
400	36.9	38.3	-36.8
450	38.0	39.6	-36.5
500	39.2	40.4	-36.0
550	41.2	42.1	-35.9
600	41.6	41.7	-35.7
650	41.9	42.9	-35.9
700	42.3	43.4	-35.6
750	43.5	43.9	-35.7
800	43.6	44.6	-36.0
850	45.0	45.1	-36.1
900	45.2	45.1	-36.6
950	46.4	46.4	-36.4
1000	45.8	47.0	-36.0

cable loss (antenna - pre-amp)	pre-amp	cable loss (inside chamber)	cable loss (to receiver)
-0,01	-38.3	0.0	0.1
0,28	-38.4	0.3	0.1
0,52	-38.7	0.5	0.2
0,73	-38.8	0.7	0.2
0,95	-38.9	1.0	0.3
1,10	-38.9	1.1	0.3
1,20	-38.6	1.2	0.3
1,29	-38.6	1.3	0.3
1,36	-38.5	1.4	0.3
1,42	-38.2	1.4	0.4
1,48	-37.9	1.5	0.4
1,54	-37.8	1.5	0.4
1,60	-37.7	1.6	0.4
1,64	-38.0	1.6	0.5
1,71	-37.8	1.7	0.5
1,76	-38.0	1.8	0.5
1,80	-38.3	1.8	0.5
1,84	-38.4	1.8	0.5
1,91	-39.0	1.9	0.5
1,93	-38.9	1.9	0.6
1,99	-38.6	2.0	0.6

Sample calculation

$E \text{ (dB } \mu\text{V/m)} = U \text{ (dB } \mu\text{V)} + AF \text{ (dB 1/m)} + Corr. \text{ (dB)}$
 U = Receiver reading
 AF = Antenna factor
 Corr. = sum of single correction factors of used cables, switch unit, distance correction, amplifier (if applicable)
 distance correction = $-20 * LOG (d_{Limit}/ d_{used})$
 Linear interpolation will be used for frequencies in between the values in the table.
 Tables show an extract of values.



ECL-TA-20-006-V01.00

TA tests on Andrew CAP MX AC 6/7E/80-
85/17E/19/23/25T

6.2 ANTENNA ROHDE & SCHWARZ HL 025 (1 GHZ – 18 GHZ)

Frequency	AF R&S HL 025	Corr.
MHz	dB (1/m)	dB
1000	33.2	-18.9
2000	39.4	-17.8
3000	42.8	-17.0
4000	45.1	-16.6
5000	46.8	-16.6
6000	48.5	-16.7
7000	50.2	-16.2
8000	50.4	-15.3
9000	51.9	-14.4
10000	53.8	-14.0
11000	54.5	-14.1
12000	55.3	-14.4
13000	55.7	-14.7
14000	56.5	-14.8
15000	56.4	-14.7
16000	57.2	-14.3
17000	57.6	-14.5
18000	57.6	-14.6

pre-amp	cable loss (to receiver)
dB	dB
-20.92	2.01
-20.60	2.78
-20.44	3.42
-20.58	3.99
-21.08	4.46
-21.53	4.87
-21.53	5.35
-20.97	5.66
-20.44	6.05
-20.43	6.45
-20.84	6.69
-21.41	7.04
-22.09	7.36
-22.48	7.66
-22.56	7.90
-22.49	8.20
-22.90	8.45
-23.27	8.71

Sample calculation

$$E \text{ (dB } \mu\text{V/m)} = U \text{ (dB } \mu\text{V)} + AF \text{ (dB 1/m)} + Corr. \text{ (dB)}$$

U = Receiver reading

AF = Antenna factor

Corr. = sum of single correction factors of used cables, switch unit, distance correction, amplifier (if applicable)

Linear interpolation will be used for frequencies in between the values in the table.

Tables show an extract of values.



ECL-TA-20-006-V01.00

TA tests on Andrew CAP MX AC 6/7E/80-85/17E/19/23/25T

6.3 ANTENNA ARA INC. MWH-1826-B (18 GHZ – 26.5 GHZ) PARTIALLY IN CONJUNCTION WITH PRE-AMPLIFIER MITEQ JS43-1800-4000: THE USE OF THE PRE-AMPLIFIER IS DEPENDENT FROM THE FIELD STRENGTH

Frequency	AF	Corr.
MHz	EMCO 3160-09 dB (1/m)	dB
18000	44.3	-37.5
18500	43.9	-37.6
19000	44.4	-36.9
19500	44.1	-36.1
20000	44.6	-36.3
20500	44.9	-36.1
21000	45.2	-35.9
21500	45.0	-35.7
22000	45.1	-35.3
22500	45.4	-35.0
23000	45.7	-35.6
23500	45.8	-34.3
24000	45.3	-34.8
24500	45.3	-35.0
25000	46.1	-34.3
25500	46.5	-34.2
26000	46.7	-34.8
26500	46.5	-34.4
27000	46.4	-35.1

pre-amp	cable loss (to receiver)
dB	dB
-46.2	8.7
-46.4	8.8
-45.9	9.0
-45.2	9.1
-45.6	9.3
-45.5	9.4
-45.3	9.4
-45.3	9.7
-45.1	9.8
-44.8	9.8
-45.5	9.9
-44.4	10.1
-45.0	10.2
-45.3	10.4
-44.8	10.5
-44.7	10.5
-45.4	10.6
-45.1	10.7
-46.0	10.9

Sample calculation

$E \text{ (dB } \mu\text{V/m)} = U \text{ (dB } \mu\text{V)} + AF \text{ (dB 1/m)} + Corr. \text{ (dB)}$
 U = Receiver reading
 AF = Antenna factor
 Corr. = sum of single correction factors of used cables, switch unit, distance correction, amplifier (if applicable)
 Linear interpolation will be used for frequencies in between the values in the table.
 Table shows an extract of values.



**BUREAU
VERITAS**

ECL-TA-20-006-V01.00

TA tests on Andrew CAP MX AC 6/7E/80-
85/17E/19/23/25T

7 MEASUREMENT UNCERTAINTIES

KDB 935210 D05	ECL
Power measurement	0,68 dB
Measuring AGC threshold level	0,90 dB
Out of band rejection	0,90 dB
Input-versus-output signal comparison	0,91 dB
Mean power output	0,90 dB
Measuring out-of-band/out-of-block (including intermodulation) emissions and spurious emissions	0,90 dB
Out-of-band/out-of-block emissions conducted measurements	0,90 dB
Spurious emissions conducted	2,18 dB
Spurious emissions radiated measurements	5,38 dB
Total frequency uncertainty	2×10^{-7}

reference :

ECL-MU5.4.6.3-EMC-14-001-V03.00 MU Wireless.xlsx

ECL-TA-20-006-V01.00

TA tests on Andrew CAP MX AC 6/7E/80-85/17E/19/23/25T

8 PHOTO REPORT

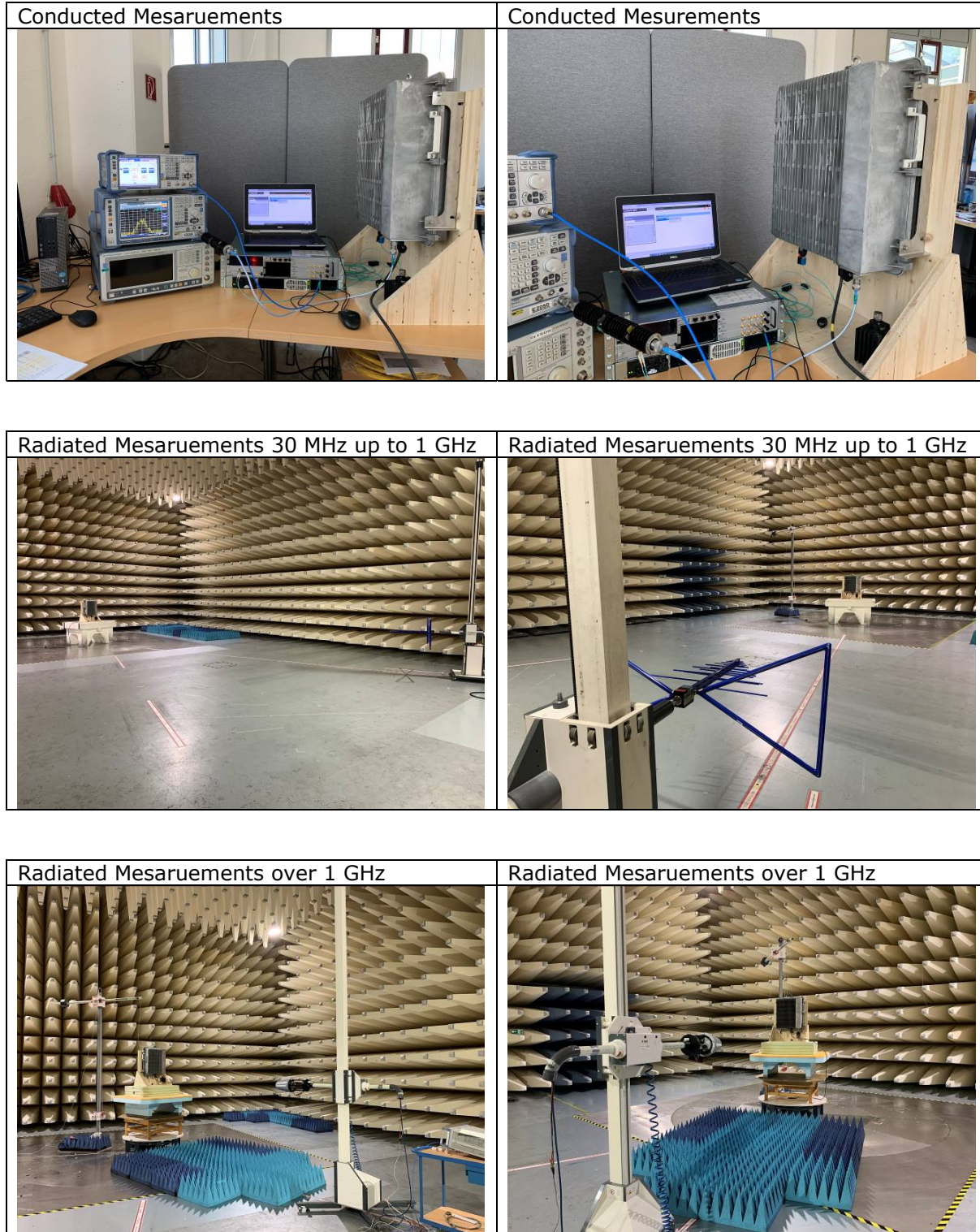



**BUREAU
VERITAS**

ECL-TA-20-006-V01.00

TA tests on Andrew CAP MX AC 6/7E/80-
85/17E/19/23/25T

Annex A: Accreditation certificate (for information)

The accreditation relates to competences stated on the accreditation certificate. The current certificate is available on the homepage of the DAkkS and can be downloaded under accredited bodies with the processing number:

<https://www.dakks.de/en>



BUREAU
VERITAS

ECL-TA-20-006-V01.00

TA tests on Andrew CAP MX AC 6/7E/80-
85/17E/19/23/25T

Annex B: Additional information provided by client

None.

***** End of test report *****