Era™
Medium Power Carrier Access Point

Installation Guide • M0201AJC • November 2018



*Preliminary draft.
Not for public release.*

DISCLAIMER

This document has been developed by CommScope, and is intended for the use of its customers and customer support personnel. The information in this document is subject to change without notice. While every effort has been made to eliminate errors, CommScope disclaims liability for any difficulties arising from the interpretation of the information contained herein. The information contained herein does not claim to cover all details or variations in equipment, nor to provide for every possible incident to be met in connection with installation, operation, or maintenance. This document describes the performance of the product under the defined operational conditions and does not cover the performance under adverse or disturbed conditions. Should further information be desired, or should particular problems arise which are not covered sufficiently for the purchaser's purposes, contact CommScope.

CommScope reserves the right to change all hardware and software characteristics without notice.

COPYRIGHT

© 2018 CommScope, Inc. All Rights Reserved.

This document is protected by copyright. No part of this document may be reproduced, stored in a retrieval system, or transmitted, in any form or by any means, electronic, mechanical photocopying, recording, or otherwise without the prior written permission of CommScope.

For patents see www.cs-pat.com.

TRADEMARKS

All trademarks identified by ® or ™ are registered trademarks or trademarks, respectively, of CommScope, Inc. Names of other products mentioned herein are used for identification purposes only and may be trademarks and/or registered trademarks of their respective companies.

Andrew Wireless Systems GmbH, 30-November-2018

TABLE OF CONTENTS

Document Overview	1
Document Revision History	1
Document Cautions and Notes.....	2
Abbreviations Used in this Guide	3
CommScope Part Numbers	3
Era System Overview	4
CAP M Overview	5
Connectors and LED for the CAP M	6
Notch-Filter Connectors	7
CAP M Hardware Options.....	7
Single Mounting Bracket	7
Dual Mounting Bracket	8
Pole Mounting Kit for Up to 18" Poles	8
Hybrid Fiber Splice Box.....	8
OCTIS Kits	8
Safely Working with Era Hardware	9
RF Safety Cautions	9
Health and Safety Precautions	9
Property Damage Warnings	9
General Installation Safety Requirements.....	10
Guard Against Damage from Electro-Static Discharge	10
Compliance	11
Equipment Symbols Used / Compliance.....	13
Installing CAP Ms	14
CAP M Installation and Cascade Rules.....	14
Cat6A Cable Requirements for Ethernet Devices	15
Prepare for Installation.....	15
Recommended Tools and Material	15
Determine the Power Consumption of the CAP M	16
Determine the Mounting Site	16
Unpack and Inspect the CAP M and Optional Accessories.....	19
Wire an Optional Hybrid Fiber Splice Box.....	19
Mount the CAP M	23
General Mounting Cautions	23
Mounting Orientation	24
Mount the CAP M to a Wall or Vertical Surface.....	25
Mount a CAP M Using a Single Mounting Bracket.....	25
Mount Two CAP Ms Using a Dual Mounting Bracket.....	31
Mount the CAP M to a 4" to 18" Pole	39
Attach a Hybrid Fiber Splice Box to the CAP M	42
Attaching a Hybrid Fiber Splice Box for a Single Mount Installation	42
Attaching a Hybrid Fiber Splice Box for a Dual Mount Installation.....	44
Grounding the CAP M	46
Connect the CAP M Cables	47
Obtain the Required Cable Material	47
Connect the CAP M to an RF Antenna.....	48
Connect the CAP M to a Classic CAN or TEN	48
Connect a Secondary CAP M (Optional).....	48
Connect an External Ethernet Device (Optional)	49
Power the CAP M.....	49
CAP M AC Power Cable	50
CAP M DC Power Cable	50
Connect the CAP M Power	51
Connect the Mains Power to the CAP M	51
Connect a Hybrid Fiber Splice Box	52
Power the CAP M	52

Contacting CommScope	53
DCCS Global Technical Support	53
Telephone Helplines.....	53
Online Support	53
Waste Electrical and Electronic Equipment Recycling.....	53
Hardware to Software Mapping Information.....	54
DCCS Technical Training	54
Accessing Era User Documentation.....	55

DOCUMENT OVERVIEW

This installation guide provides a product overview of and installation instructions for the Medium Power Carrier Access Point (CAP M), which allows transmission between Era equipment, antennas, and Ethernet devices (such as WiFi and IP cameras).

Table 1 lists the CAP M models that this installation guide supports.

Table 1. Supported CAP M Models

Part Number ¹	Model Name
7781125-000x	CAP M 9/18/21/26
7820478-000x	CAP M 7E/80-85/17E/19
1 The "-000x" suffix provides information as to whether the CAP M is AC or DC. Contact your local sales representative for further information. See also " CommScope Part Numbers " on page 3.	



For information on other Era system components, refer to the Era™ software and hardware user documentation, which can be accessed on the CommScope DCCS Customer Portal (see "[Accessing Era User Documentation](#)" on page 55.)



For information on how to find the minimum software requirements for Era hardware, refer to "[Hardware to Software Mapping Information](#)" on page 54.

Document Revision History

This is the second release of the *Medium Power Carrier Access Point Installation Guide*, which updates "[Compliance](#)" on page 11.

The second release of the *Medium Power Carrier Access Point Installation Guide* did the following:

- added support for the new Era system configuration and WCS Subrack functions and modes that were introduced in Era Software Version 2.5; for an overview see "[Era System Overview](#)" on page 4
- updated [Figure 1 on page 5](#), which shows an Era system in which the CAP Ms connect to a Classic CAN
- updated "[Recommended Tools and Material](#)" on page 15
- updated "[General Mounting Cautions](#)" on page 23
- updated "[Mount a CAP M Using a Single Mounting Bracket](#)" on page 25 and "[Mount Two CAP Ms Using a Dual Mounting Bracket](#)" on page 31—the M6x12 screw now requires an M6 plain washer and an M6 split-lock washer
- added "[Pole Mounting Kit for Up to 18" Poles](#)" on page 8 and "[Mount the CAP M to a 4" to 18" Pole](#)" on page 39.

Document Cautions and Notes

This document may contain any of the following notes, cautions, and warning icons.



The icon to the left is used to indicate a caution or warning. Cautions and warnings indicate operations or steps that could cause personal injury, induce a safety problem in a managed device, destroy or corrupt information, or interrupt or stop services.



The icon to the left indicates a caution or warning that pertains to laser equipment.



The icon to the left indicates a caution or warning that pertains to Radio Frequency (RF).



The icon to the left indicates that the hardware is susceptible to Electro-Static Discharge (ESD) damage.



The icon to the left indicates a caution or warning that pertains to an electrical hazard.



The icon to the left indicates a caution or warning that pertains to a fire hazard.



The icon to the left indicates a Note. Notes provide information about special circumstances.

Abbreviations Used in this Guide

AC	Alternating Current	Gb	Gigabyte
AP	Access Point	GHz	Gigahertz
AUX	Auxiliary	GUI	Graphical User Interface
C	Celsius	ISDE	Innovation, Sciences et Développement économique Canada
CAN	Central Area Node	ISED	Innovation, Science and Economic Development Canada
CAP H	Carrier Access Point, High Power	kg	Kilogram
CAP L	Carrier Access Point, Low Power	LED	Light Emitting Diode
CAP M	Carrier Access Point, Medium Power	MHz	Megahertz
Cat	Category	mm	Millimeter
CAT	Copper Transport	MMF	Multi-Mode Fiber
dB	Decibel	OPT	Optical Transport
dBm	Decibel-milliwatts	PN	Part Number
DC	Direct Current	RAN	Regional-Area Network
DC	Direct Current	RF	Radio Frequency
DCCS	Distributed Coverage and Capacity Solutions	RU	Rack Unit
EFTA	European Free Trade Association	SFP	Small Form-Factor Pluggable
EMC	Electromagnetic Compatibility	SMF	Single-Mode Fiber
EMEA	Europe, Middle East, Africa	TEN	Transport Expansion Node
EU	European Union	UAP	Universal Access Point
F	Fahrenheit	Vdc	Volts, direct current
FCC	Federal Communications Commission	W	Watts

CommScope Part Numbers

The CommScope part numbers in this installation guide are in the format of *nnnnnnn-xx*, where the “-xx” suffix indicates the latest release. Contact your local CommScope sales representative for the current release part number.

ERA SYSTEM OVERVIEW

Era™ coordinates wireless capacity throughout the entire coverage area via a single centralized head-end location or from an operator's existing C-RAN hub. Based on ION®-E, Era operates on the same cost-efficient standard IT cabling as ION-E and is compatible with ION-E deployments. Era systems bring together licensed wireless and power, plus Gigabit Ethernet for WiFi into one wireless system that can scale to building size and is technology and spectrum agnostic and adaptive. An Era system comprises the components listed below.

- **Central Area Node (CAN)**—provides server-level control and primary signal distribution. It combines the signals from multiple operators and distributes those signals within a venue or multiple venues. There are two configuration modes available for the CAN: **Classic** and **Switching**.
 - The **Classic CAN** configuration is appropriate for when all the BTS and Baseband sources are located in a centralized space in the same venue as the Classic CAN. You install RF Donor (RFD) Cards and CPRI Digital Donor (CDD) Cards in a Classic CAN, which digitizes the analog BTS signals from the RFD Cards and combines those with the BBU CPRI digital signals from the CDD Cards, and then distributes the RF signals to the TENS. The TENS then provide the RF signals to the Access Points (APs). The Classic CAN also supports APs that are directly connected to CAT or OPT Cards installed in the Classic CAN chassis. Wide-area Integration Nodes (WINs) are not supported by a Classic CAN. Users have full and flexible control of all signal routing via the Era GUI.
 - The **Switching CAN** configuration is appropriate for when WINs are required to allow operators to bring in baseband signals from multiple remote locations to fully leverage the C-RAN architecture in their hubs. All operator Baseband signals (analog BTS and BBU CPRI) are supplied to the Switching CAN by the WINs, so no RFD or CDD Cards can be installed in the Switching CAN. The Switching CAN then combines the signals from all WINs and distributes those signals to the TENS, and the TENS provide the signals to the APs. APs are not directly connected to a Switching CAN. Users have full and flexible control of all signal routing via the Era GUI.



This guide uses “CAN” to collectively refer to Central Area Nodes. When information pertains to a specific CAN mode, “Classic CAN” and “Switching CAN” will be used.

- **Wide-Area Integration Node (WIN)**—interfaces between a Switching CAN and RF sources, which makes C-RAN possible in Era by allowing operators to bring in signals from multiple remote locations kilometers away. You install RFD and CDD Cards in the WIN, which takes the analog BTS signals from the RFD Cards and combines those with the BBU CPRI digital signals from the CDD Cards, and distributes the RF sources to a Switching CAN.
- **Transport Expansion Node (TEN)**—is an expansion node connected to the CAN via fiber and can be located throughout the venue coverage area. A single TEN can support, dependent on the AP type and powering method, 12 to 32 Access Points (APs), which greatly reduces the number of fiber runs between the head-end and each AP.
- **Access Point (AP)**—connects a Classic CAN or TEN to antennas or other wireless devices. On the downlink, an AP converts data arriving at the AP to analog signals and sends them to an antenna. On the uplink, received signals are digitized and serialized into data streams which are sent back to the Classic CAN or TEN. APs support Gigabit Ethernet pass-through for WiFi, IP cameras, or other devices in addition to wireless over a common cable. An AP can be any of the Universal Access Points or Carrier Access Points.



This guide uses “Access Point (AP)” to collectively refer to the Universal Access Points (UAPs) and the Carrier Access Point (CAPs), and “Fiber APs” to collectively refer to Fiber CAP Ls and CAP Ms. When information pertains to a specific AP type, that AP will be identified.

CAP M OVERVIEW

This installation guide describes the Medium Power Carrier Access Point (CAP M), which interfaces via an optical link with a Classic CAN, or with a TEN. This allows the CAP M to provide data over Single-Mode Fiber (SMF), or Multi-Mode Fiber (MMF). Power for CAP Ms is provided over embedded AC/DC (AC version) or remotely through hybrid fiber (DC version).

On the downlink, the CAP M converts data arriving at the CAP M to analog signals and sends them to the Antenna port. On the uplink, received signals are digitized and serialized into data streams, which are sent back to the Classic CAN or TEN. Each CAP M can provide RF coverage for up to four specific frequency bands. [Figure 1](#) shows how a CAP M can be deployed in an Era system.

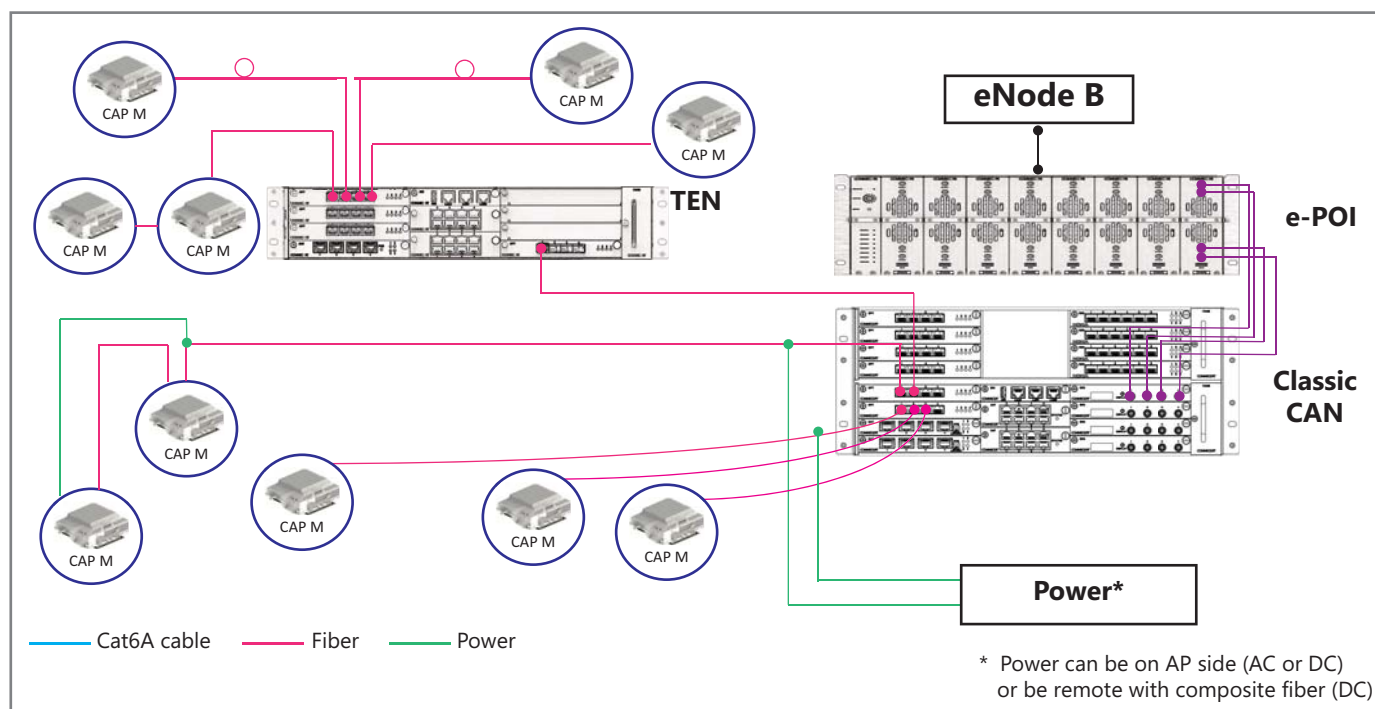

Figure 1. CAP M in an Era System using a Classic CAN



All APs can only connect to a TEN or a Classic CAN. APs cannot connect to a Switching CAN or to a WIN.

The CAP M

- is passively cooled and operates within the following temperature ranges:
-33°C to +52°C (-27.4°F to 125.6°F)
- is rated for indoor and outdoor (IP66) installations; see ["Determine the Mounting Site"](#) on page 16
- has a typical power consumption of 140W; see also ["Determine the Power Consumption of the CAP M"](#) on page 16.

Connectors and LED for the CAP M

Figure 2 and Table 2 identify the CAP M connectors and its LED; corresponding connectors are shown.



Do not remove caps from any of the connectors until instructed to do so.

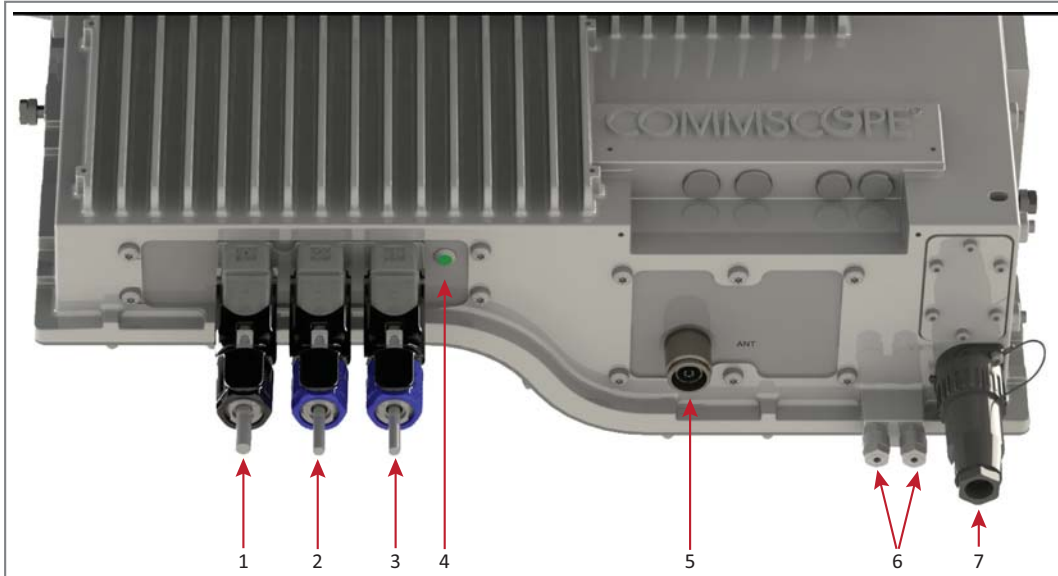

Figure 2. CAP M Connectors and LED

Table 2. Function of the CAP M Connectors and LED

REF #	Label	Description	Function
1	A	RJ45 Auxiliary port	Connects to external Ethernet devices such as WiFi and IP cameras. Cabling is via the appropriate CAT cable for the protocol; this model supports a 1000 BASE-T and 802.3at Class 4 Power over Cat6A Ethernet connection. Maximum attached cable length is 3 meters (9.8 feet). For information on the Auxiliary port in cascades, see "CAP M Installation and Cascade Rules" on page 14. Port A ships with factory-installed EMI/weatherproof plug and must remain plugged if not in use. (Graphic shows the port populated with an OCTIS Ethernet connector PN 7760652 which must be ordered separately—see "OCTIS Kits" on page 8.)
2	2	Optical Port 2	If the CAP M is functioning as a Primary CAP M in a cascade, Optical Port 2 connects to Optical Port 1 of the Secondary CAP M via the Optical OCTIS Kit (PN 7770612), which ships with the unit, to provide the main signal interface. Optical transport occurs over Single Mode Fiber (SMF) or Multi Mode Fiber (MMF). Port 2 ships with factory-installed EMI/weatherproof plug and must remain plugged if not in use. Graphic shows the OCTIS connector in blue.
3	1	Optical Port 1	Connects to a Classic CAN or TEN (possibly through a local Hybrid Fiber Junction Box) and provides the main signal interface; if Secondary CAP M in a cascade, Optical Port 1 connects to Optical Port 2 of the Primary CAP M. Optical transport occurs over Single Mode Fiber (SMF) or Multi Mode Fiber (MMF). Uses the Optical OCTIS Kit (PN 7770612), which ships with the unit. Port 1 ships with a dust cap that can be discarded upon unit installation. Graphic shows the OCTIS connector in blue.
4	Unlabeled	Power LED	See "Power the CAP M" on page 52.
5	ANT	4.3-10 RF connector	Transmits and receiving signals to and from distributed antennas. This RF port can be connected directly to an antenna (using RF jumper cables) or through splitters, allowing additional antennas to be fed by the CAP M.
6	Unlabeled	Grounding bolts	Connects the CAP M to an approved earth-ground source.
7	Mains	Power connector (Vac or Vdc)	Connects to any of the following (graphic shows the port populated): <ul style="list-style-type: none"> • Vac—Main power • Vdc—Remote DC power supply or a Hybrid Fiber Junction Box.

Notch-Filter Connectors

The CAP M 7E/80-85/17E/19 has two Notch-Filter connectors that are reserved for future use. The connectors, which are closed by a jumper, have a protective cover. **Do not remove the protective cover or interfere with the jumper.**

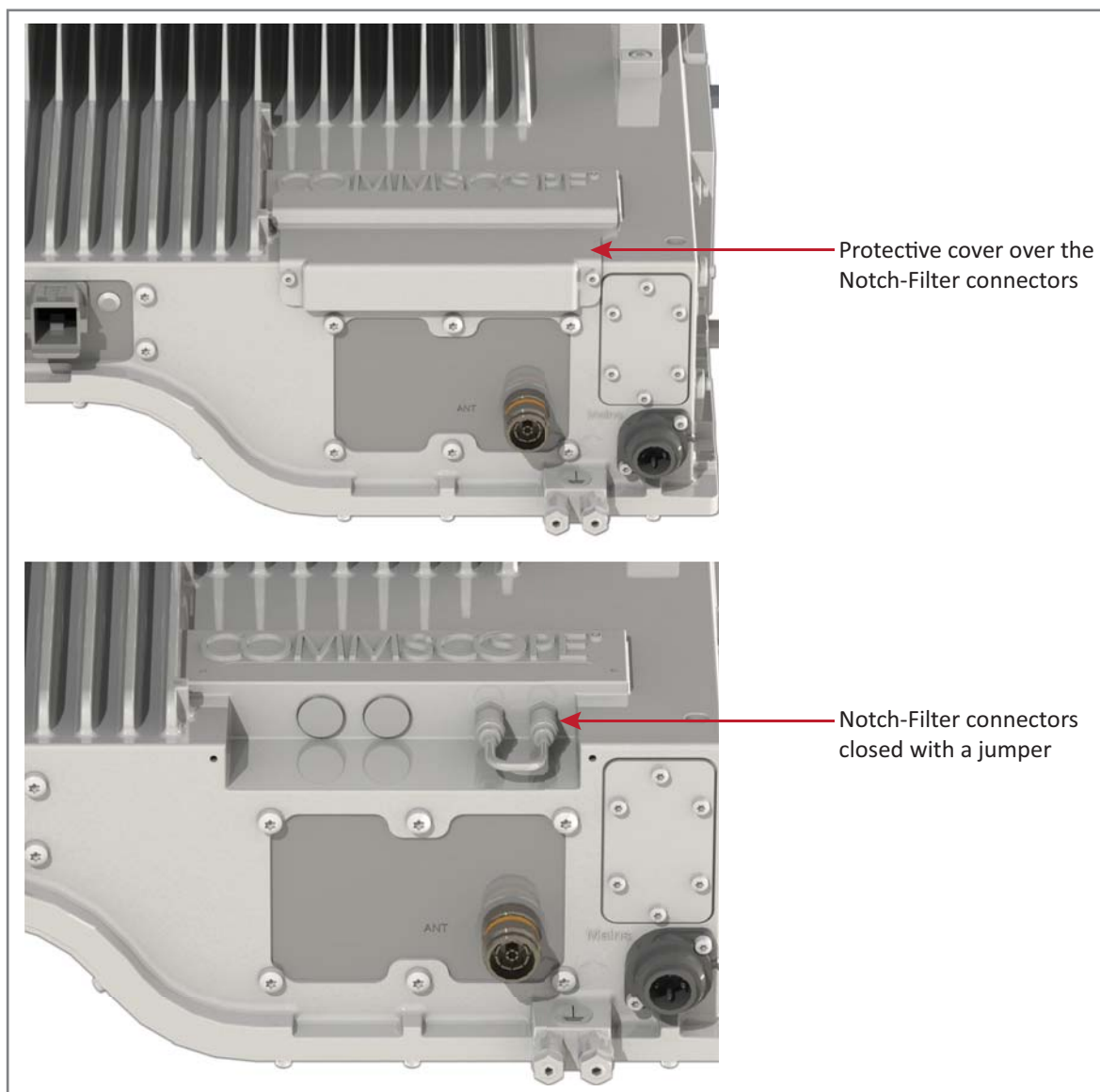

Figure 3. Notch-Filter Connector on the CAP M 7E/80-85/17E/19

CAP M Hardware Options

The following sections describe hardware options for the CAP M.

Single Mounting Bracket

The Single Mounting Bracket (CommScope PN 7821954-xx) provides the mounting brackets required to mount an CAP M to a wall or other vertical, flat surface. See "[Mount a CAP M Using a Single Mounting Bracket](#)" on page 25.

Dual Mounting Bracket

The Dual Mounting Bracket (CommScope PN 7821955-xx) provides the mounting brackets required to mount two CAP Ms back-to-back in a single bracket, which is then mounted to a wall or other vertical, flat surface. See ["Mount Two CAP Ms Using a Dual Mounting Bracket"](#) on page 31.

Pole Mounting Kit for Up to 18" Poles

The CAP M Pole Mounting Kit for Up to 18" Poles (CommScope PN 7692096-XX) is used to mount a CAP M to a pole with a circumference of 4" to 18" (10.2 cm to 45.8 cm). See ["Mount the CAP M to a 4" to 18" Pole"](#) on page 39.

Hybrid Fiber Splice Box

The Hybrid Fiber Splice Box (CommScope PN 7693816-xx) separates the power from the fiber signals on a hybrid fiber feed from the Classic CAN or TEN. It feeds power to the CAP M through a composite cable that includes both fiber and copper power wires. Fiber and copper terminate at the Splice Box, which allows you to separate the DC wires and fiber at the remote end. For CAP Ms, you will typically use composite cable to transport signal and power, and then use the Hybrid Fiber Splice Box to terminate the fiber at the CAP M. See ["Wire an Optional Hybrid Fiber Splice Box"](#) on page 19.

OCTIS Kits

All CAP Ms include one OCTIS¹ Kit for the primary interface to the Classic CAN or TEN that CAP M plugs into the CAP M Optical Port 1. You can order an additional OCTIS Kit, which would allow you to cascade two CAP Ms via Optical Port 2, or to attach an auxiliary Ethernet device via the AUX Port. [Table 3](#) identifies the two OCTIS Kit options.

Table 3. CAP M OCTIS Kits

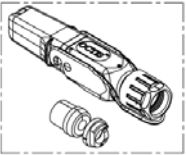
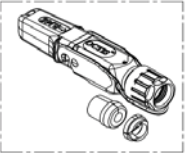
Kit Name	CommScope PN	Description
	Optical OCTIS Kit 7770612	This is the SFP+ connector that you use to cascade a Secondary Fiber CAP L; one Optical OCTIS Kit ships with each Fiber CAP L. Use as follows: <ul style="list-style-type: none"> • Optical Port 1—to connect the CAP M to a Classic CAN or TEN. • Optical Port 2—to cascade a second CAP M. • SFP+ Module must be ordered separately, it is not included as part of the Optical OCTIS Kit.
	Ethernet OCTIS Kit 7760652	This is the RJ-45 connector that you use to attach an auxiliary Ethernet device. The Ethernet OCTIS Kit must be ordered separately.

¹ OCTIS is a trademark of RADIALL.

SAFELY WORKING WITH ERA HARDWARE

The following sections provide important information that you should read and know before working with any Era hardware. Observe all cautions and warnings listed in this section.

RF Safety Cautions



This system is a RF Transmitter and continuously emits RF energy. Maintain a minimum 8-inch (20 cm) clearance from the antenna while the system is operating. Whenever possible, shut down the RAN before servicing the antenna.



Only license holders for the respective frequency range are allowed to operate this unit.

Health and Safety Precautions



A high leakage current ground (earth) connection to the Power Supply Unit (PSU) is essential before making any other connections to the PSU.



Laser radiation. Risk of eye injury in operation. Do not stare into the laser beam; do not view the laser beam directly or with optical instruments.



High frequency radiation in operation. Risk of health hazards associated with radiation from the antenna(s) connected to the unit. Implement prevention measures to avoid the possibility of close proximity to the antenna(s) while in operation.

Property Damage Warnings



Keep operating instructions within easy reach and make them available to all users.



Only license holders for the respective frequency range are allowed to operate this unit.



Read and obey all the warning labels attached to the unit. Make sure that all warning labels are kept in a legible condition. Replace any missing or damaged labels.



Make sure the unit's settings are correct for the intended use (refer to the manufacturer product information) and regulatory requirements are met. Do not carry out any modifications or fit any spare parts, which are not sold or recommended by the manufacturer.



Due to power dissipation, the CAP M may reach a very high temperature. Do not operate this equipment on or close to flammable materials. Use caution when servicing the CAP M.



Only authorized and trained personnel are allowed to open the unit and get access to the inside.



Only suitably qualified personnel are allowed to work on this unit and only after becoming familiar with all safety notices, installation, operation and maintenance procedures contained in this installation guide.



Although the unit is internally protected against overvoltage, it is strongly recommended to ground (earth) the antenna cables close to the antenna connectors of the unit for protection against atmospheric discharge. In areas with strong lightning, it is strongly recommended to install additional lightning protection.

General Installation Safety Requirements



Wet conditions increase the potential for receiving an electrical shock when installing or using electrically powered equipment. To prevent electrical shock, never install or use electrical equipment in a wet location or during a lightning storm.



This system is a RF Transmitter and continuously emits RF energy. Maintain a minimum 8-inch (20 cm) clearance from the antenna while the system is operating. Whenever possible, shut down the RAN before servicing the antenna.



Do not remove caps from any of the connectors until instructed to do so.



The CAP M is to be used only with CommScope (NEC Class 2) or Limited Power Source Era Subrack, or equivalent.



Read and observe all the warning labels attached to the unit. Make sure that all warning labels are kept in a legible condition. Replace any missing or damaged labels.

Guard Against Damage from Electro-Static Discharge



Electro-Static Discharge (ESD) can damage electronic components. To prevent ESD damage, always wear an ESD wrist strap when working with Era hardware components. Not all Era hardware requires grounding. For those hardware components for which grounding is required, connect the ground wire on the ESD wrist strap to an earth ground source before touching the component. Wear the wrist strap the entire time that you work with the hardware.

Compliance

- 1 Notice:** For installations, which have to comply with FCC RF exposure requirements, the antenna selection and installation must be completed in a way to ensure compliance with those FCC requirements. Depending on the RF frequency, rated output power, antenna gain, and the loss between the repeater and antenna, the minimum distance D to be maintained between the antenna location and human beings is calculated according to this formula:

$$D_{[cm]} = \sqrt{\frac{P_{[mW]}}{4 * \pi * PD_{[mW/cm^2]}}}$$

where

- P (mW) is the radiated power at the antenna, i.e. the max. rated repeater output power in addition to the antenna gain minus the loss between the repeater and the antenna.
- PD (mW/cm²) is the allowed Power Density limit acc. to 47 CFR 1.1310 (B) for general population / uncontrolled exposures which is
 - f (MHz) / 1500 for frequencies from 300MHz to 1500MHz
 - 1 for frequencies from 1500MHz to 100,000MHz

RF exposure compliance may need to be addressed at the time of licensing, as required by the responsible FCC Bureau(s), including antenna co-location requirements of 1.1307(b)(3).

- 2 Notice:** For installations which have to comply with European EN50385 exposure compliance requirements, the following Power Density limits/guidelines (mW/cm²) according to ICNIRP are valid:
- 0.2 for frequencies from 10 MHz to 400 MHz
 - F (MHz) / 2000 for frequencies from 400 MHz to 2 GHz
 - 1 for frequencies from 2 GHz to 300 GHz
- 3 Notice:** Installation of this equipment is in full responsibility of the installer, who has also the responsibility, that cables and couplers are calculated into the maximum gain of the antennas, so that this value, which is filed in the FCC Grant and can be requested from the FCC data base, is not exceeded. The industrial boosters are shipped only as a naked booster without any installation devices or antennas as it needs for professional installation.
- 4 Notice:** For installations which have to comply with FCC/ISED requirements:

English:

This device complies with FCC Part 15. Operation is subject to the following two conditions: (1) this device may not cause interference, and (2) this device must accept any interference, including interference that may cause undesired operation of the device.

This device complies with Health Canada's Safety Code. The installer of this device should ensure that RF radiation is not emitted in excess of the Health Canada's requirement. Information can be obtained at http://www.hc-sc.gc.ca/ewh-semt/pubs/radiation/radio_guide-lignes_direct-eng.php.

Changes or modifications not expressly approved by the party responsible for compliance could void the user's authority to operate the equipment.

This device contains license-exempt transmitter(s)/receiver(s) that comply with Innovation, Science and Economic Development Canada's license-exempt RSS(s). Operation is subject to the following two conditions:

- 1 This device may not cause interference.
- 2 This device must accept any interference, including interference that may cause undesired operation of the device.

Antenna Stmt for ISED:

This device has been designated to operate with the antennas having a maximum gain of 9 dBi. Antennas having a gain greater than 9 dBi are prohibited for use with this device without consent by ISED regulators. The required antenna impedance is 50 ohms.

The antenna(s) used for this transmitter must be installed to provide a separation distance of at least 100 cm from all persons and must not be co-located or operating in conjunction with any other antenna or transmitter. Users and installers must be provided with antenna installation instructions and transmitter operating conditions for satisfying RF exposure compliance.

French:

Cet appareil est conforme à FCC Partie 15. Son utilisation est soumise à Les deux conditions suivantes: (1) cet appareil ne peut pas provoquer d'interférences et (2) cet appareil doit accepter Toute interférence, y compris les interférences qui peuvent causer un mauvais fonctionnement du dispositif.

Cet appareil est conforme avec Santé Canada Code de sécurité 6. Le programme d'installation de cet appareil doit s'assurer que les rayonnements RF n'est pas émis au-delà de l'exigence de Santé Canada. Les informations peuvent être obtenues:

http://www.hc-sc.gc.ca/ewh-semt/pubs/radiation/radio_guide-lignes_direct-eng.php

Les changements ou modifications non expressément approuvés par la partie responsable de la conformité pourraient annuler l'autorité de l'utilisateur à utiliser cet équipement.

L'émetteur/récepteur exempt de licence contenu dans le présent appareil est conforme aux CNR d'Innovation, Sciences et Développement économique Canada applicables aux appareils radio exempts de licence. L'exploitation est autorisée aux deux conditions suivantes :

- 1 L'appareil ne doit pas produire de brouillage;
- 2 L'appareil doit accepter tout brouillage radioélectrique subi, même si le brouillage est susceptible d'en compromettre le fonctionnement.

Antenne Stmt pour ISDE:

Ce dispositif a été désigné pour fonctionner avec les antennes ayant un gain maximal de 9 dBi. Antennes ayant un gain plus grand que 9 dBi sont interdites pour une utilisation avec cet appareil sans le consentement des organismes de réglementation d'ISDE. L'impédance d'antenne requise est 50 ohms.

L'antenne (s) utilisé pour cet émetteur doit être installé pour fournir une distance de séparation d'au moins 100 cm de toutes les personnes et ne doit pas être co-localisées ou opérant en conjonction avec une autre antenne ou émetteur. Les utilisateurs et les installateurs doivent être fournis avec des instructions d'installation de l'antenne et des conditions de fonctionnement de l'émetteur pour satisfaire la conformité aux expositions RF.

- 3 **Notice:** The unit complies with Overvoltage Category II. It also complies with the surge requirement according to EN 61000-4-5 (fine protection); however, installation of an additional medium (via local supply connection) and/or coarse protection (external surge protection) is recommended depending on the individual application in order to avoid damage caused by overcurrent.

For Canada and US, components used to reduce the Overvoltage Category shall comply with the requirements of IEC 61643-series. As an alternative, components used to reduce the Overvoltage Category may comply with ANSI/IEEE C62.11, CSA Certification Notice No. 516, CSA C22.2 No. 1, or UL 1449. Suitability of the component for the application shall be determined for the intended installation.

- 4 **Notice:** Corresponding local particularities and regulations must be observed. For national deviations, please refer to the respective documents included in the manual CD that is delivered with the unit.

5 Note: For a Class B digital device or peripheral:

This equipment has been tested and found to comply with the limits for a Class B digital device, pursuant to part 15 of the FCC Rules. These limits are designed to provide reasonable protection against harmful interference in a residential installation. This equipment generates, uses and can radiate radio frequency energy and, if not installed and used in accordance with the instructions, may cause harmful interference to radio communications. However, there is no guarantee that interference will not occur in a particular installation. If this equipment does cause harmful interference to radio or television reception, which can be determined by turning the equipment off and on, the user is encouraged to try to correct the interference by one or more of the following measures:

- Reorient or relocate the receiving antenna.
- Increase the separation between the equipment and receiver.
- Connect the equipment into an outlet on a circuit different from that to which the receiver is connected.
- Consult the dealer or an experienced radio/TV technician for help.

6 Notice: For a Class A digital device or peripheral.

This equipment has been tested and found to comply with the limits for a Class A digital device, pursuant to Part 15 of the FCC Rules. These limits are designed to provide reasonable protection against harmful interference when the equipment is operated in a commercial environment. This equipment generates, uses, and can radiate radio frequency energy and, if not installed and used in accordance with the instruction manual, may cause harmful interference to radio communications. Operation of this equipment in a residential area is likely to cause harmful interference in which case the user will be required to correct the interference at his own expense.

7 Note: This unit complies with European standard EN60950-1 / EN62368-1.

Equipment Symbols Used / Compliance

Please observe the meanings of the following symbols used in our equipment and the compliance warnings listed in [Table 4](#).

Table 4. Compliance Labels

Symbol	Compliance	Meaning
—	FCC	For industrial (Part 20) signal booster: WARNING: This is NOT a CONSUMER device. It is designed for installation by FCC LICENSEES and QUALIFIED INSTALLERS. You MUST have an FCC LICENSE or express consent of an FCC Licensee to operate this device. Unauthorized use may result in significant forfeiture penalties, including penalties in excess of \$100,000 for each continuing violation.
—	ISED	WARNING: This is NOT a CONSUMER device. It is designed for installation by an installer approved by an ISED licensee. You MUST have an ISED LICENCE or the express consent of an ISED licensee to operate this device. AVERTISSEMENT: Ce produit N'EST PAS un appareil de CONSOMMATION. Il est conçu pour être installé par un installateur approuvé par un titulaire de licence d'ISDE. Pour utiliser cet appareil, vous DEVEZ détenir une LICENCE d'ISDE ou avoir obtenu le consentement exprès d'un titulaire de licence autorisé par ISDE.
CE	CE	To be sold exclusively to mobile operators or authorized installers - no harmonized frequency bands, operation requires license. Intended use: EU and EFTA countries. Indicates conformity with the RED directive 2014/53/EU and/or RoHS directive 2011/65/EU.
CE 0700	CE	Indicates conformity with the RED directive 2014/53/EU and RoHS directive 2011/65/EU certified by the notified body no. 0700.

INSTALLING CAP Ms

The following sections guide you through the installation of a CAP M. Pay attention to all cautions and follow the steps in the order presented.

CAP M Installation and Cascade Rules

When cascading a Secondary CAP M or an external Ethernet device such as WiFi or an IP camera, you must observe the following rules.

- You connect CAP Ms to an OPT Card in the Classic CAN or TEN.
 - Each OPT Card has four 10 Gbps ports (labeled 1 - 4) for fiber connections.
 - You can connect up to 4 CAP Ms per OPT Card for a total of 16 Primary and 32 total, per Classic CAN or TEN.
- In a cascade, the CAP M connected directly to the Classic CAN or TEN is the Primary CAP M, and the CAP M that connects to the Primary CAP M is the Secondary CAP M.
- The total 320 MHz RF bandwidth is shared between the two cascaded units, but can be shared unevenly; that is, with more bandwidth going to either the Primary or Secondary CAP M—either CAP M can transmit all the 320 MHz RF bandwidth or any subset of it.
- The Primary and Secondary CAP Ms power up as soon as power is applied to them. In a cascade, the GUI discovers and readies the Primary CAP M for RF first, and then the Secondary CAP M will be discovered and readied for RF. For information on the Power LED behavior, see ["Power the CAP M" on page 52](#).
- SMF or MMF connects the CAP M via its Optical Port 1 to the OPT Card.
- When cascading a Secondary CAP M or an external Ethernet device such as WiFi or an IP camera, you must observe the following rules.
 - To cascade two CAP Ms, use a fiber-optic cable.
 - SMF or MMF connects the Secondary CAP M via its Optical Port 1 to the Primary CAP M via its Optical Port 2.
 - You can connect the following to the Primary CAP M
 - a Secondary CAP M
 - an Ethernet device
 - both a Secondary CAP M and an Ethernet device.
- To add a Secondary AP, you must add an Optical OCTIS kit to the Primary CAP L, see ["OCTIS Kits" on page 8](#).
- To add an Ethernet device, you must add an RJ45 OCTIS kit to the Primary CAP L, see ["OCTIS Kits" on page 8](#).

Cat6A Cable Requirements for Ethernet Devices

If you connect an Ethernet device to a Fiber CAP L, you must observe the following rules.

- Plenum rated cable must be used whenever it is required by local electrical codes.
- Shielded twisted pair is not required unless operating in a high RFI/EMI environment.
- CommScope strongly recommends using factory terminated and tested Cat6A Patch Cord.
- 24 AWG Cat6A cabling is sufficient for the cable run between the Fiber CAP L and the Ethernet device.
- The maximum attached cable length at Port A is 3 meters (9.8 feet).

Prepare for Installation

Do the following before beginning installation.

- Review and know the cautions in ["Safely Working with Era Hardware"](#) on page 9.
- Review the system design plan.
- Identify the equipment installation site, which must be able to support the weight of the CAP M, see ["Determine the Mounting Site"](#) on page 16.
- Review the power requirements to make sure the site can support this installation.
- Map out all cable runs.
- Identify and obtain all tools and materials required to complete the installation; see ["Recommended Tools and Material"](#) on page 15

Recommended Tools and Material

The following tools and material is required for installation are not supplied by CommScope.

- Electrostatic Discharge (ESD) wrist strap
- Drill and bits that can penetrate the selected mounting surface
- SW10 wrench
- Single Mount
 - Single Mounting Bracket (CommScope PN 7821954-xx)
 - Four M6 screw anchors rated for the mounting surface
- Dual Mount
 - Dual Mounting Bracket (CommScope PN 7821955-xx)
 - Four M6 screw anchors rated for the mounting surface
- For installations using the optional Hybrid Fiber Splice Box
 - Hybrid Fiber Splice Box (CommScope PN 7693816-xx)
 - Torx T20H screwdriver
- Earth-bonding cable to ground the CAP M chassis
- Fiber cleaning equipment.

Determine the Power Consumption of the CAP M

Use the power consumption matrix in [Table 5](#) to calculate power consumption for a CAP M, where

- the consumption numbers are at the CAP M power inputs and do not account for feed losses
- the maximum consumption numbers in [Table 5](#) do not include the power consumed by any attached auxiliary devices. Both CAP M power consumption and auxiliary device power must be included when calculating feed losses.

Table 5. CAP M Power Consumption

Configuration	Voltage Range (V)	Typical Power (W)	Maximum Power (W)
DC ¹	36 - 60 Vdc	140	150
AC ¹	100 - 264 Vac	140	150
¹ Does not include SFP+ Module consumption. Can support up to 3W (more with engineering consultation) maximum total SFP+ Module consumption. Typical installation (sufficient for SM up to 10km or MM) would be 0.8W typical, 1.0W max for each SFP+ Module.			



Mains power must be interruptible with an external delay-actions mains breaker. For the Mains breaker, observe the following recommendations.

- For the AC power supply, 120 Volt / 20 Amp max. or 240 Volt / 16 Amp, single-phase, 50 / 60 Hz AC service is needed, i.e. the external AC breaker should be 20 Amps max. for 120-Volt service or 13 to 16 Amps for 240-Volt service.
- For the DC power supply, observe the local regulations of the DC service provider.

Determine the Mounting Site

When deciding on a suitable mounting site, observe the following rules; refer also to "[Mounting Orientation](#)" on page 24.

- The CAP M is suitable for installation indoors or outdoors.
- Use the weights listed in [Table 6](#) to determine a site that can bear the weight of the CAP M that is being installed, where:
 - The “Maximum Lift Weight” is the highest weight that must be lifted during installation. (An installer should lift the CAP M components one at a time, not a wholly configured CAP M.)
 - The “Total Hanging Weight” is the weight of the CAP M, including the weight of the Mounting Bracket, minus the weight of the external cables and connectors, that the mounting site must be able to support.

Table 6. Maximum CAP M Installation Weights¹

CAP M installed with this option ...	Maximum Lift Weight		Total Hanging Weight	
	kg	lbs.	kg	lbs.
Single Mounting Bracket (PN 7821954-xx)	19.2	42.3	20.5	45.2
Dual Mounting Bracket (PN 7821955-xx)	19.2	42.3	40	88.2
¹ A Hybrid Fiber Splice Box (PN 7693816-xx) adds 0.3 kg (.66 lbs.) to the total weights.				

- Use the dimensions shown in [Figure 4 on page 17](#) for Single Mount and [Figure 5 on page 18](#) for Dual Mount.

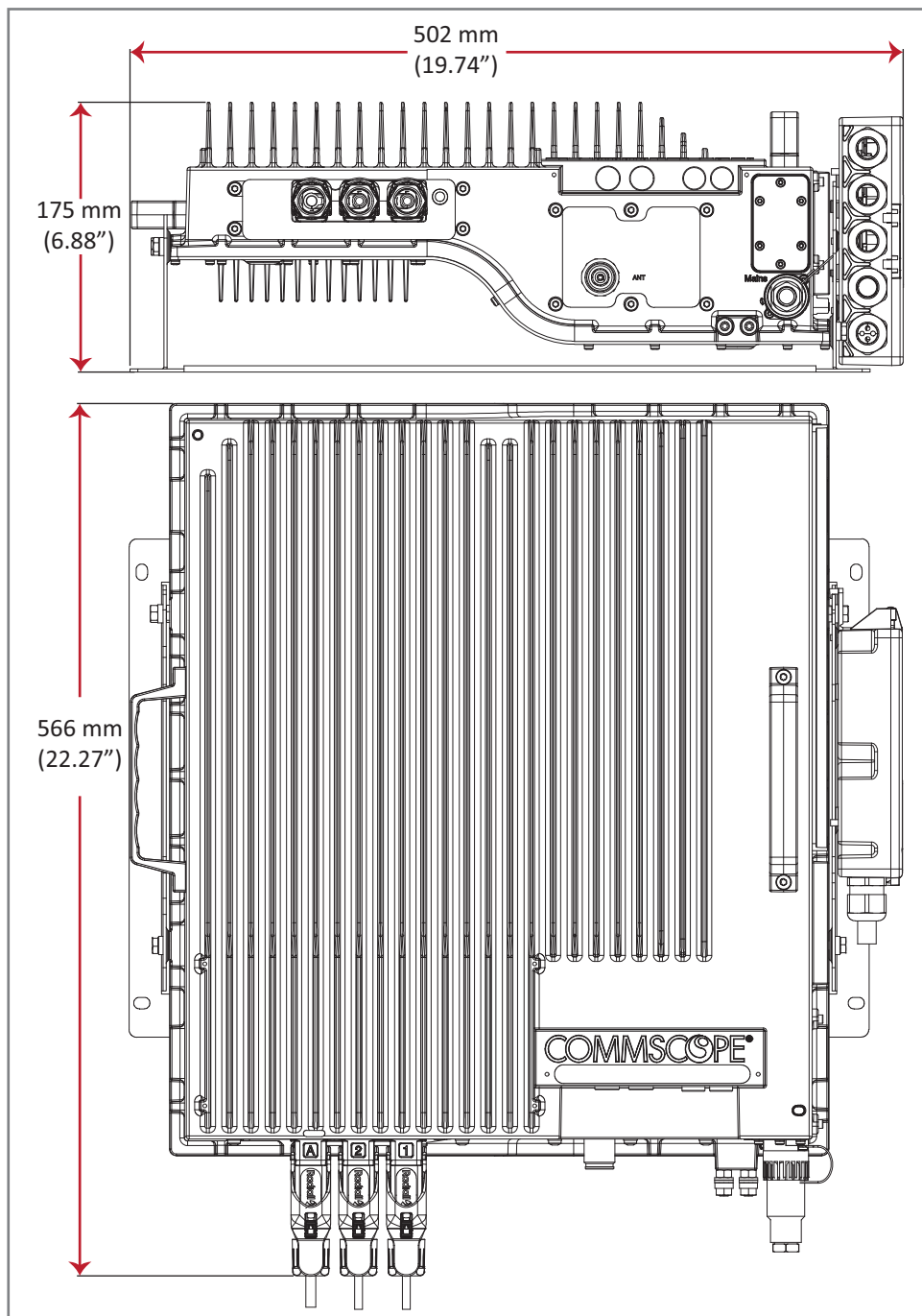

Figure 4. Mounting Dimensions with the Single Mounting Bracket

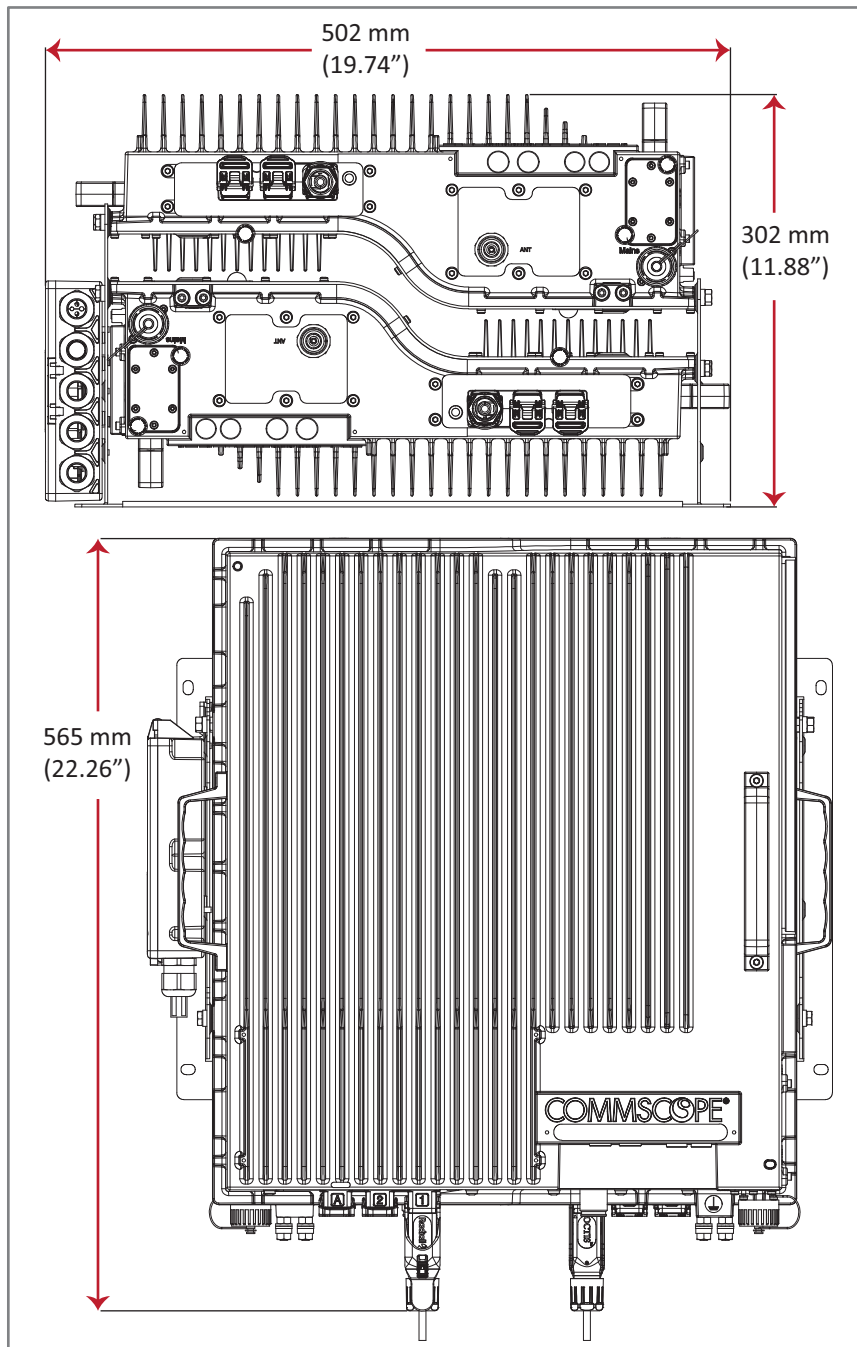

Figure 5. Mounting Dimensions with the Dual Mounting Bracket

Unpack and Inspect the CAP M and Optional Accessories

- 1 Inspect the exterior of the shipping container(s) for evidence of rough handling that may have damaged the components in the container.
- 2 Unpack each container while carefully checking the contents for damage and verify with the packing slip.
- 3 If damage is found or parts are missing, file a claim with the commercial carrier and notify CommScope Technical Support (see ["DCCS Global Technical Support" on page 53](#)). Save the damaged cartons for inspection by the carrier.
- 4 Save all shipping containers for use if the equipment requires shipment at a future date.

Wire an Optional Hybrid Fiber Splice Box



The steps in this section pertain only to those installations that require the use of the optional Hybrid Fiber Splice Box to provide fiber and power to the CAP M. If the optional Hybrid Fiber Splice Box is not required for this installation, skip to ["Mount the CAP M" on page 23](#).

- 1 Obtain the Hybrid Fiber Splice Box Kit (CommScope PN 7693816-xx).
- 2 Follow the steps in ["Unpack and Inspect the CAP M and Optional Accessories" on page 19](#).
- 3 Open the Hybrid Fiber Splice Box and remove the installation kit that is inside.

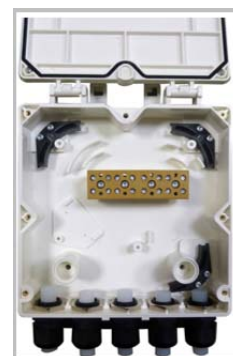

- 4 Using the parts from the Hybrid Fiber Splice Box, insert the Splice Holder and fasten it using a PTK 30x6 screw and one M4 washer.

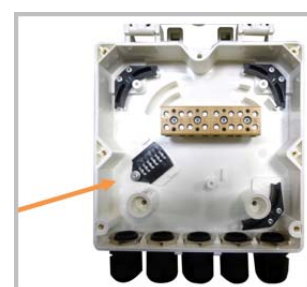

- From the Hybrid Fiber Splice Box Kit, insert Fiber Patch Cord in one of the cable glands indicated in the graphic to the right.

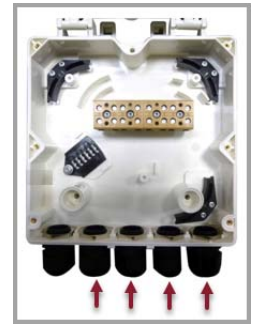

- Strip the insulation of the composite cable for 100 cm and the fibers for 90 cm, and then shorten the copper cables to 25 cm.

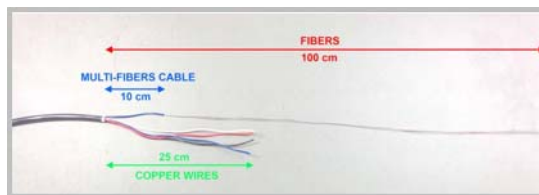

- Insert the composite cable in the first cable gland and separate the multi-fibers cable from the copper wires. It is necessary to remove the nut to perform this action. The cable must be fed through the nut and it must be retightened once finished.

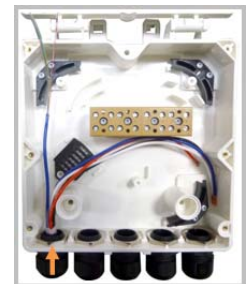

- Bend the spliced fibers using the corner guides and fix the splices to the splice holder.

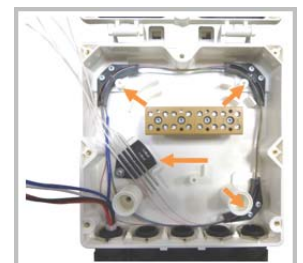

- Bend the optical cables as shown in the graphic to the right.

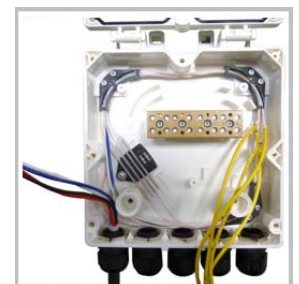

- 10** If a second splice holder is needed, it can be assembled using the M4 insulating washer and two M4 plain washers, as shown to the right. The required screw is a PTK30 x 12.



- 11** Remove the sealing nut and rubber of the cable gland and insert the optical cables.



- 12** Place each cable into one of the grooves of the seal insert.



- 13** Press the seal insert into the clamp ring opening.



- 14** Fix the optical cables inside the box using one cable tie and tight the sealing nut.

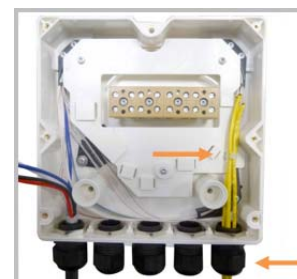

- 15** It is possible to separate the optical cables and use two different cable glands. Remove the sealing nut and rubber on each cable gland.



- 16** Close all unused grooves with the plastic cylinders, no matter if one or two cable glands are used.



- 17 Insert the copper wires in the first multiple terminal connectors. See markings on the internal support. Then fasten the copper cables inside the box using one cable tie.

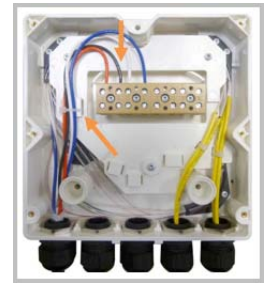

- 18 Remove the sealing nut and insert the CAP M supply cable and tighten the sealing nut.



- 19 Connect the supply cable to the terminal strip and fix it inside the box using one cable tie.

In the instance when two CAP Ms are in a dual mount or a cascade, it is possible to connect a second power supply cable. In the figure to the right, **1** and **2** refers to two CAP Ms.

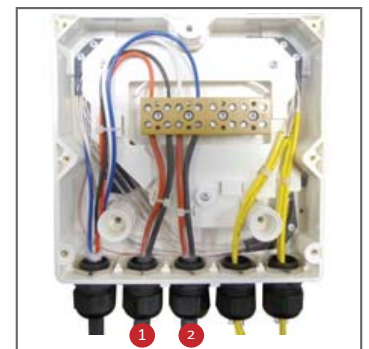

Mount the CAP M

The CAP M is suitable for indoor and outdoor installations.

General Mounting Cautions

The following cautions apply to all CAP M installations; there may be other mounting cautions applicable to a specific mounting option, which will be defined in the applicable mounting procedure.



Attach all CAP Ms securely to a stationary object as described in this installation guide.



To maintain proper ventilation, keep at least 76 mm (3-inch) clearance around the CAP M.



The installation site must be able to bear the weight of the CAP M; see [Table 6 on page 16](#).



Risk of injury by the weight of the unit falling. Ensure there is adequate manpower to handle the weight of the system.



Risk of serious personal injury by equipment falling due to improper installation. Installers must verify that the supporting surface will safely support the combined load of the electronic equipment and all attached hardware and components. For wall mounts, the screws and dowels (wall anchors) used should also be appropriate for the structure of the supporting wall.



If any different or additional mounting material is used, ensure that the mounting remains as safe as the mounting designed by the manufacturer. The specifications for stationary use of the CAP M must not be exceeded. Ensure that the static and dynamic strengths are adequate for the environmental conditions of the site. The mounting itself must not vibrate, swing or move in any way that might cause damage to the CAP M.

Mounting Orientation



CAP Ms are passively cooled and must therefore always be mounted with its ANT port pointing down, as shown in [Figure 6](#).

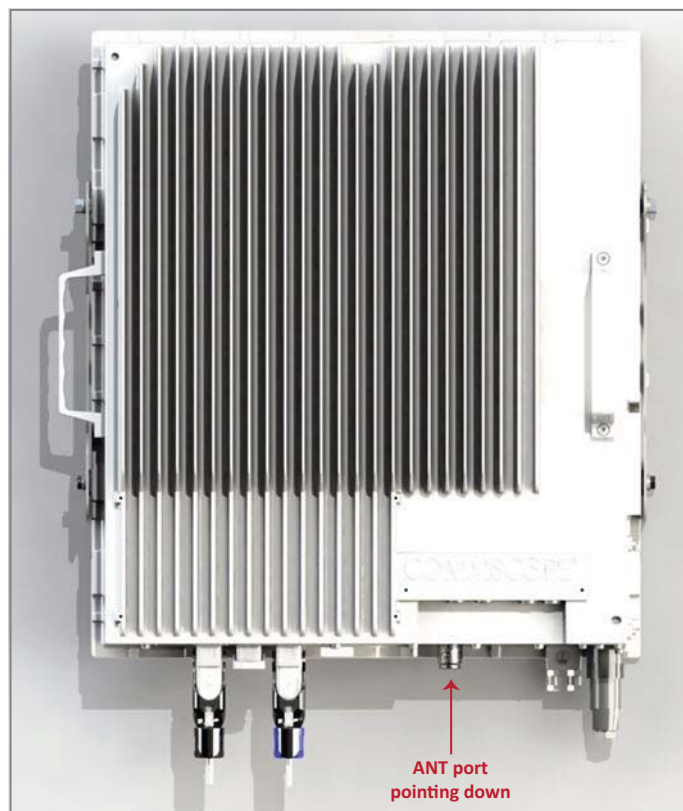

Figure 6. Mounting Orientation for a CAP M

Mount the CAP M to a Wall or Vertical Surface

There are two mounting options for the CAP M; follow the procedure that is appropriate for this installation:

- ["Mount a CAP M Using a Single Mounting Bracket" on page 25](#)
- ["Mount Two CAP Ms Using a Dual Mounting Bracket" on page 31.](#)



If this installation requires the optional Hybrid Fiber Splice Box to provide fiber and power to the CAP M, follow the steps in

Mount a CAP M Using a Single Mounting Bracket

- 1 Obtain the CAP M Single Mounting Bracket (CommScope PN 7821955-xx).
- 2 Follow the steps in ["Unpack and Inspect the CAP M and Optional Accessories" on page 19](#). Table 7 lists the parts that ship with the CAP M Single Mounting Bracket.

Table 7. Parts List for CommScope PN 7821955-XX

Description	Quantity
Single Wall-Mounting Bracket	2

- 3 Refer to ["Determine the Mounting Site" on page 16](#) to determine the mounting location, which must be able to support the weight and dimensions of the CAP M.



Installer must verify that the mounting surface will safely support the combined load of the electronic equipment and all attached hardware and components.

- 4 Refer to ["Mounting Orientation" on page 24](#) to determine the mounting orientation of the CAP M.
- 5 Refer to and observe all cautions listed in ["General Mounting Cautions" on page 23](#).

6 Secure the Mounting Bracket to the wall (or other suitable vertical surface) shown to the right.

- a Install the mounting bracket using 4 M6 screw anchors (not included) or suitable lag bolts according to the drilling layout.



The M6 screw anchors do not ship with the CAP M as the anchor type is dependent on the on-site conditions (wall structure and materials). Use screw anchors that are rated for the mounting surface.

- b Confirm that the Mounting Bracket is securely fastened to the wall.

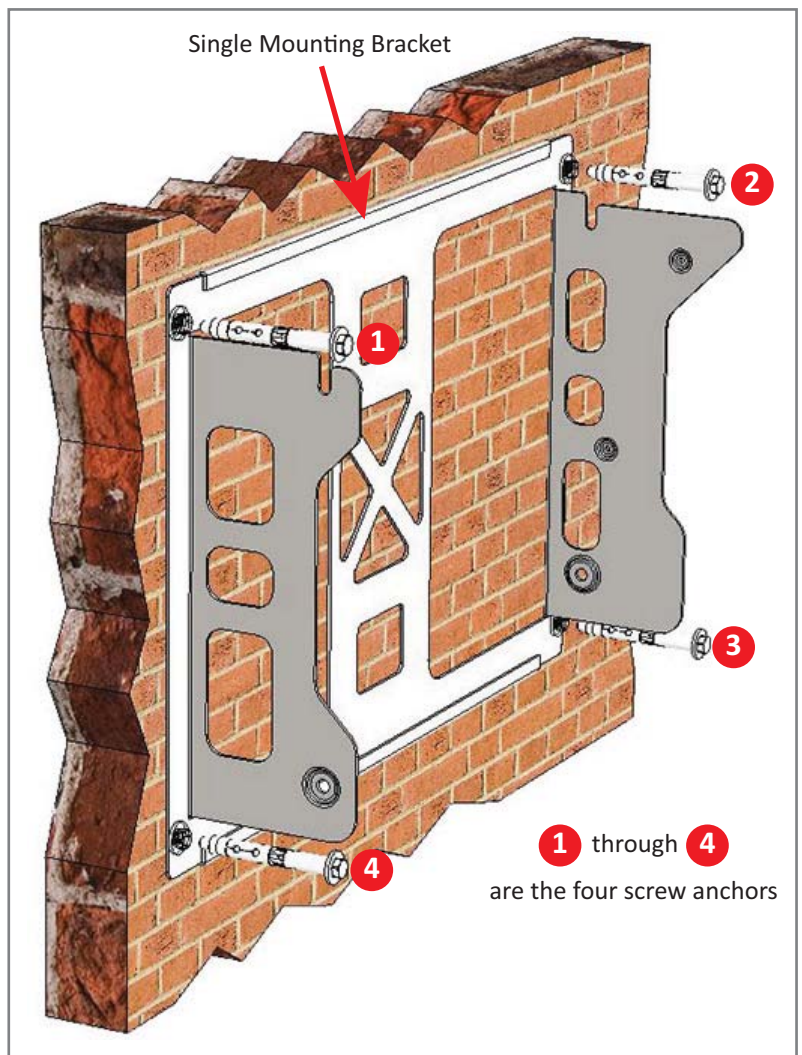

- 7 From both sides of the CAP M:
 - a Loosen the M6 pins, leaving its washer in place.
 - b Remove the two M6 screws and their M6 plain and M6 split-lock washers; reserve the screws and washers as you will later reinstall them.

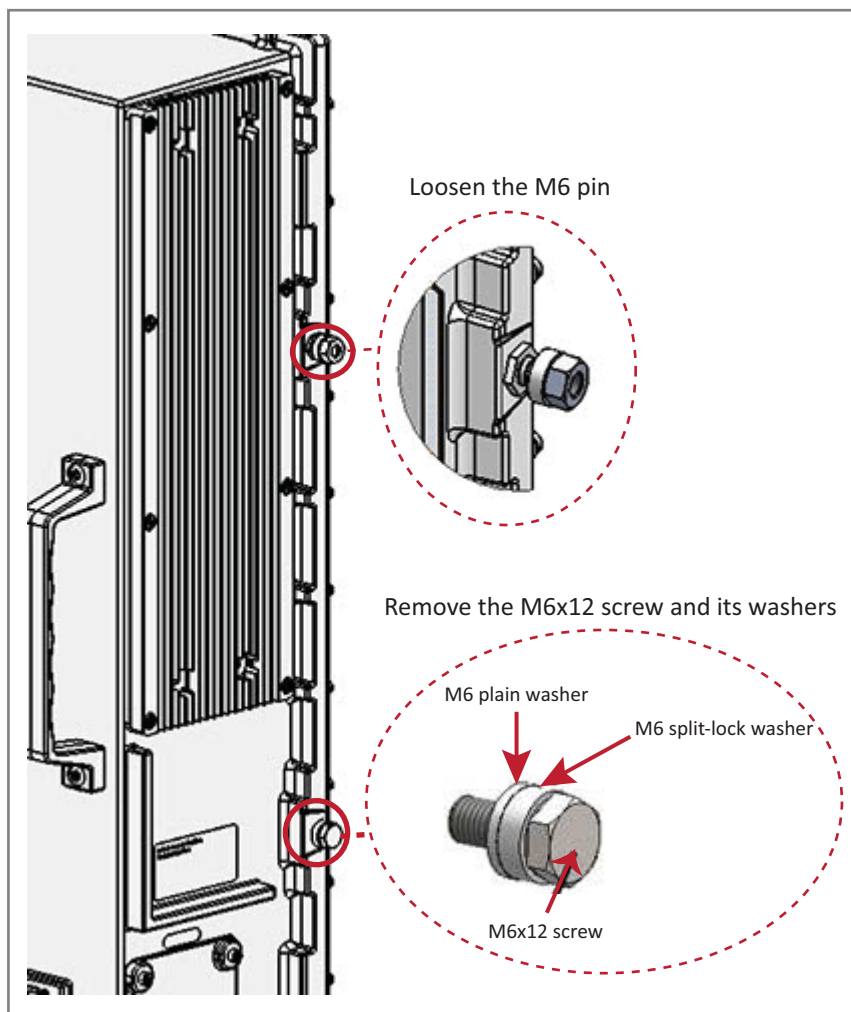

- Use both handles on the CAP M to lift it above the Mounting Bracket, and then lower it into place. The M6 pins that you loosened in [Step 7 on page 27](#) must align with the Mounting Bracket slots, as shown below.

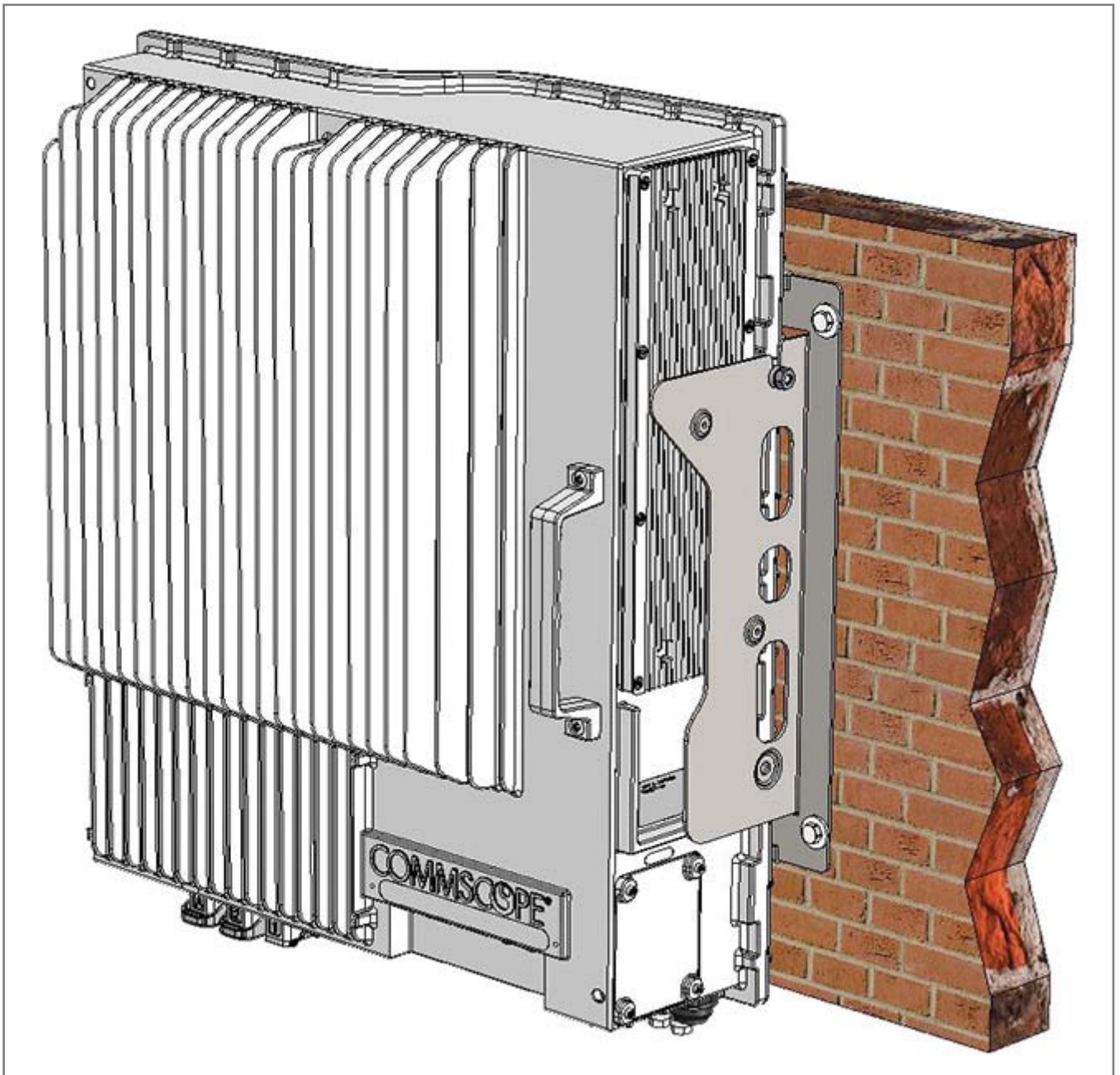

- 9 On the right side of the CAP M, slide a washer over the threaded M6 pin, and then secure the CAP M to the Mounting Bracket by torquing the M6 pin to 11 N-m.

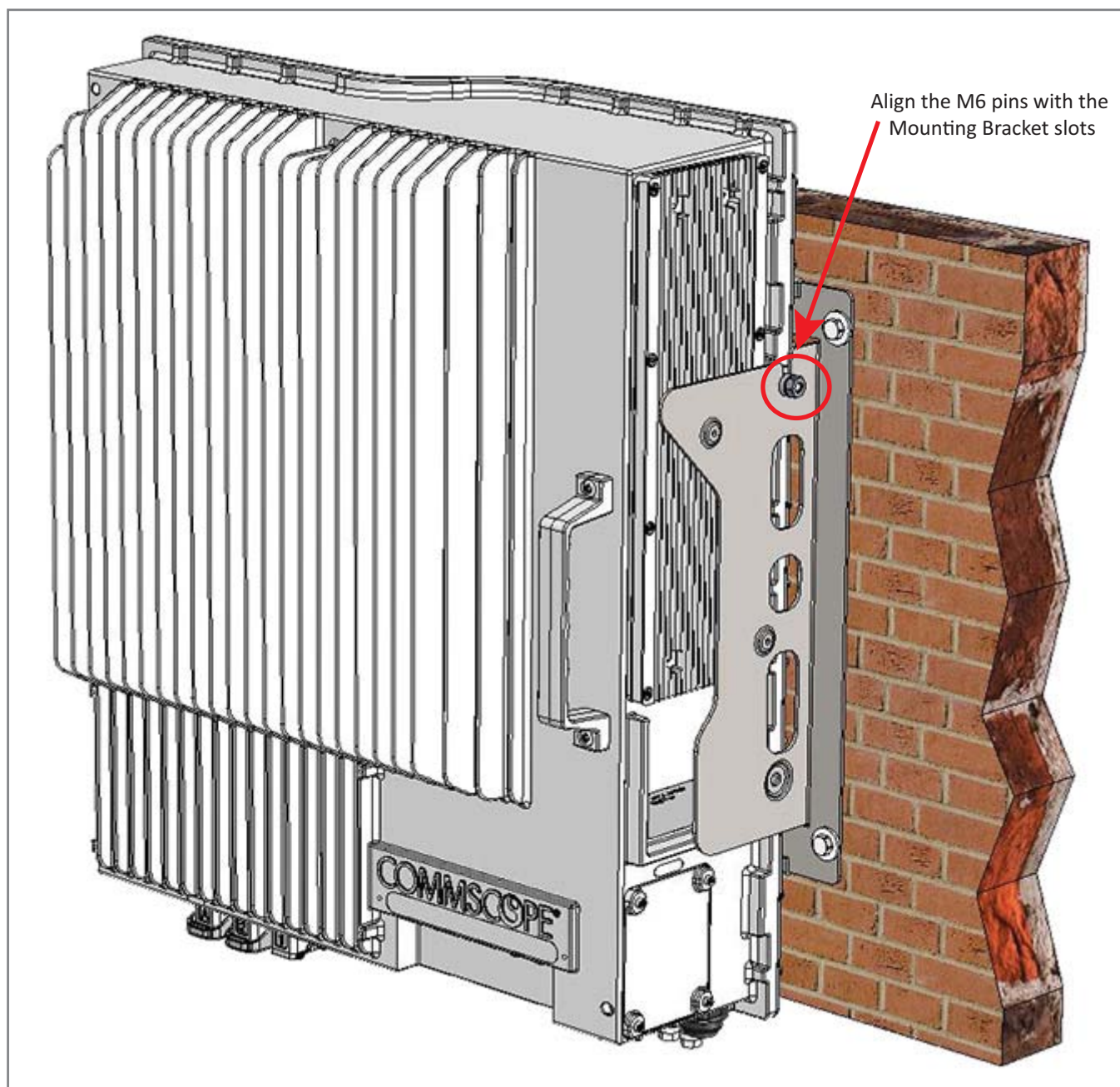

- 10 Repeat [Step 9](#) on the left side of the CAP M.

- 11 On lower right of the CAP M, reinstall the M6x12 screw and its washers that you removed in [Step 7 on page 27](#).
 - a Slide first the M6 plain washer and then the M6 split-lock washer over the M6x12 screw.
 - b Insert the M6x12 screw through the screw hole shown below, and screw it back into the CAP M chassis; torque to 11 N-m.

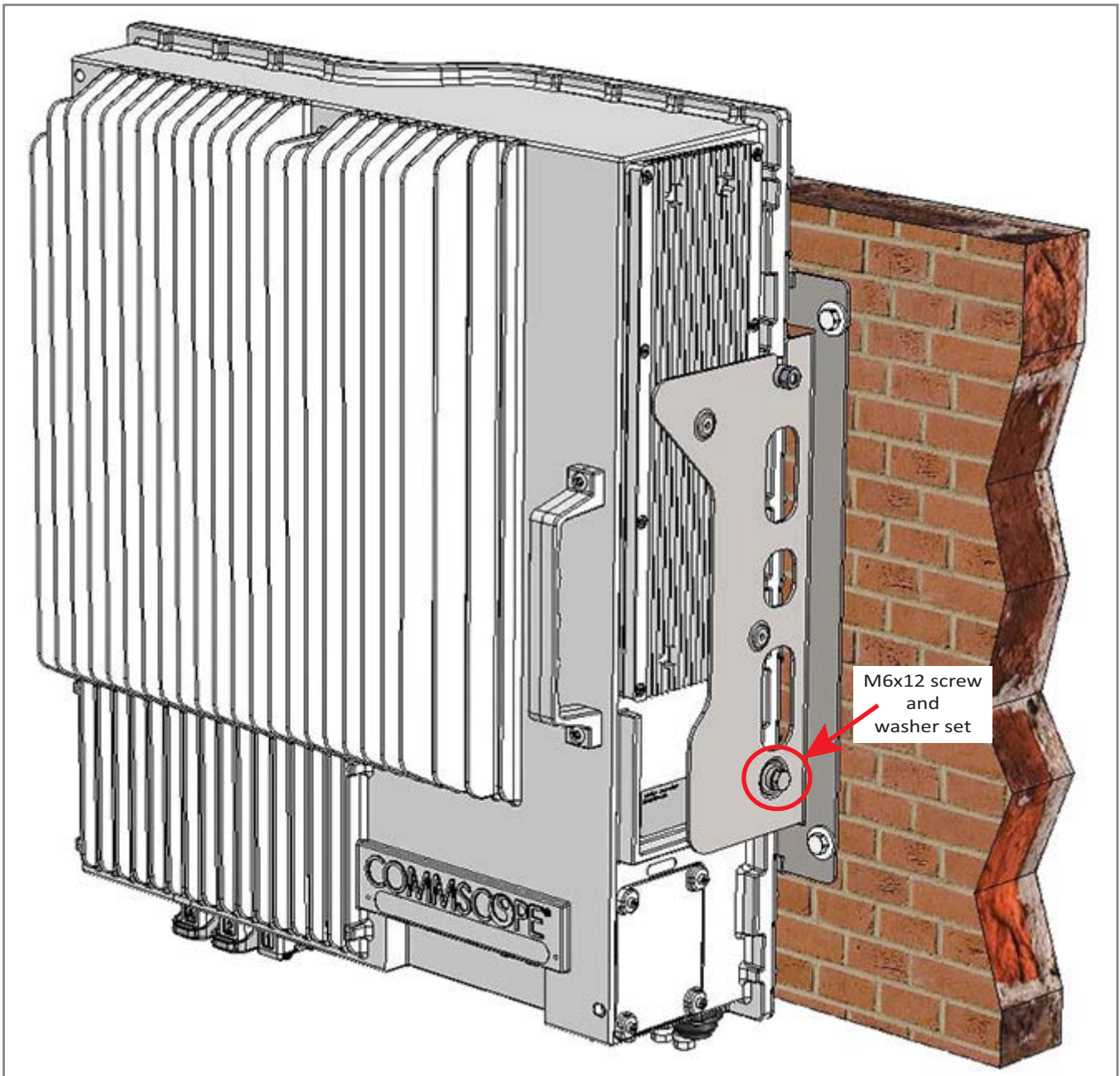

- 12 Repeat [Step 11](#) on the left side of the CAP M.
- 13 Do one of the following:
 - If this installation requires a Hybrid Fiber Splice Box, go to ["Attach a Hybrid Fiber Splice Box to the CAP M" on page 42](#).
 - If this installation does **not** a Hybrid Fiber Splice Box, go to ["Grounding the CAP M" on page 46](#).

Mount Two CAP Ms Using a Dual Mounting Bracket

In this procedure you will mount two CAP Ms back-to-back in one Dual Mounting Bracket. The steps in this procedure will identify the two CAP Ms as CAP M-1 and CAP M-2, as shown in [Figure 7](#).

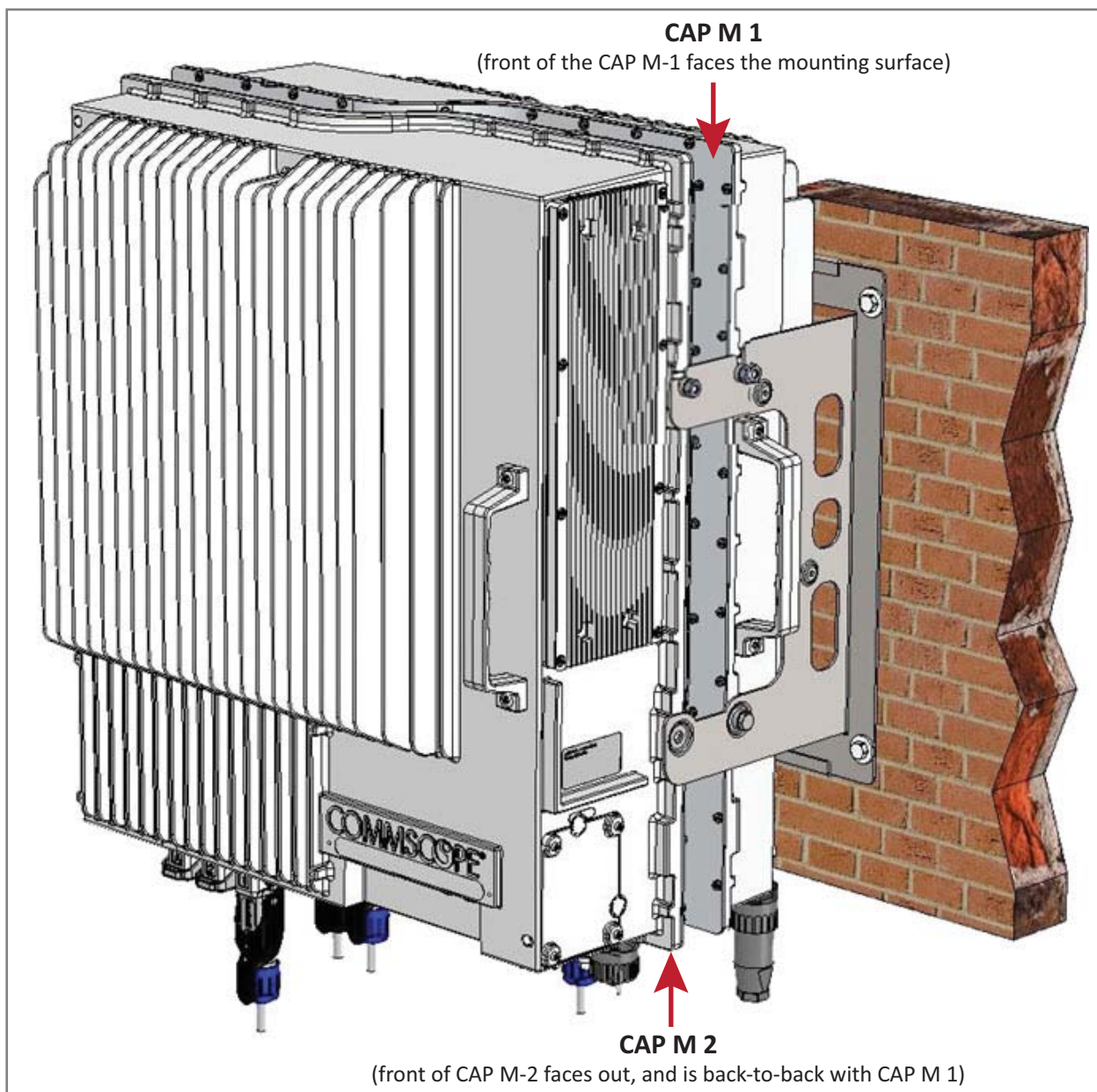

Figure 7. Two CAP Ms Back-to-Back in a Dual Mounting Bracket

Do the following to mount two CAP Ms in a Dual Mounting Bracket.

- 1 Obtain the Dual Mounting Bracket (CommScope PN 7821954-xx).
- 2 Follow the steps in "[Unpack and Inspect the CAP M and Optional Accessories](#)" on page 19. [Table 8](#) lists the parts that ship with the CAP M Dual Mounting Bracket.

Table 8. Parts List for CommScope PN 7821954-XX

Description	Quantity
Dual Wall Mounting Bracket	2

- 3 Refer to "[Determine the Mounting Site](#)" on page 16 to determine the mounting location, which must be able to support the weight and dimensions of the CAP M.



Installer must verify that the mounting surface will safely support the combined load of the electronic equipment and all attached hardware and components.

- 4 Refer to "[Mounting Orientation](#)" on page 24 to determine the mounting orientation of the CAP M.
- 5 Refer to and observe all cautions listed in "[General Mounting Cautions](#)" on page 23.
- 6 Secure the Mounting Bracket to the wall (or other suitable vertical surface) as shown below.
 - a Install the mounting bracket using 4 M6 screw anchors (not included) or suitable lag bolts according to the drilling layout.



The M6 screw anchors do not ship with the CAP M as the anchor type is dependent on the on-site conditions (wall structure and materials). Use screw anchors that are rated for the mounting surface.

- b Confirm that the bracket is securely fastened to the wall.

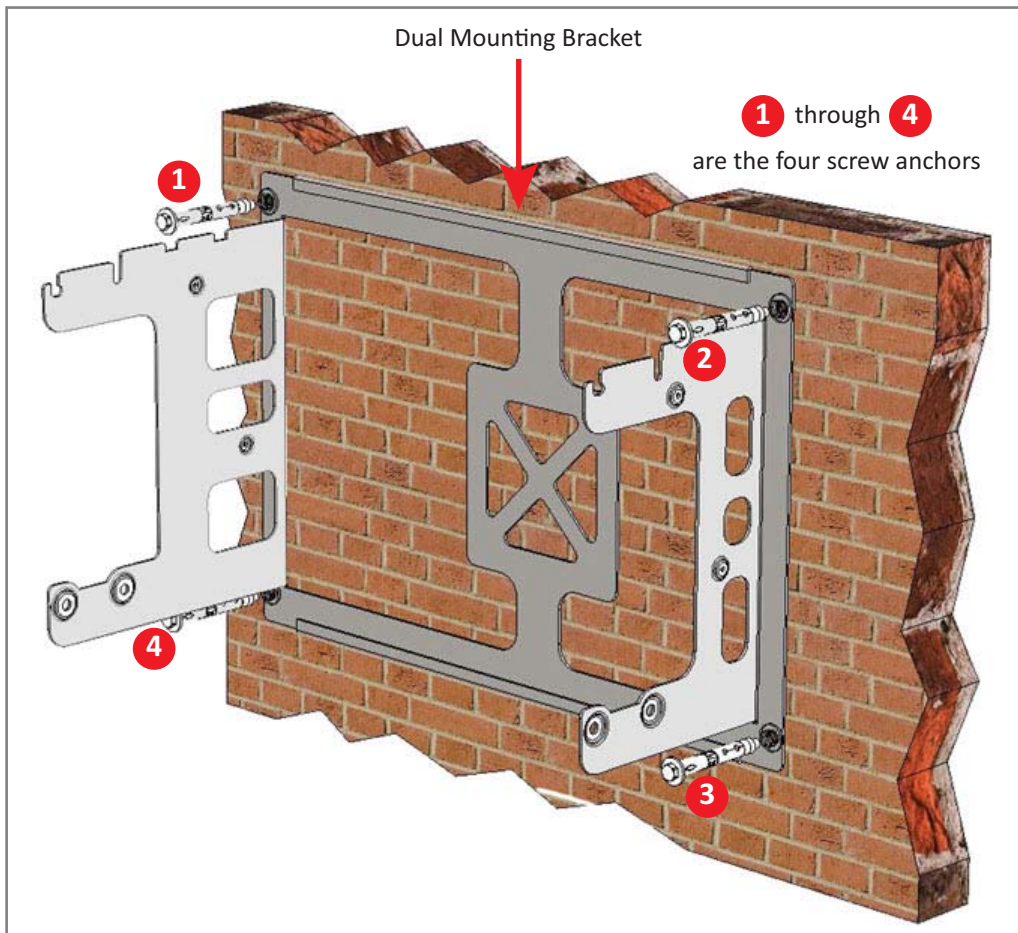

- 7 From both sides of CAP M-1:
 - a Loosen the M6 pins, leaving its washer in place.
 - b Remove the two M6 screws and their M6 plain and M6 split-lock washers; reserve the screws and washers as you will later reinstall them.

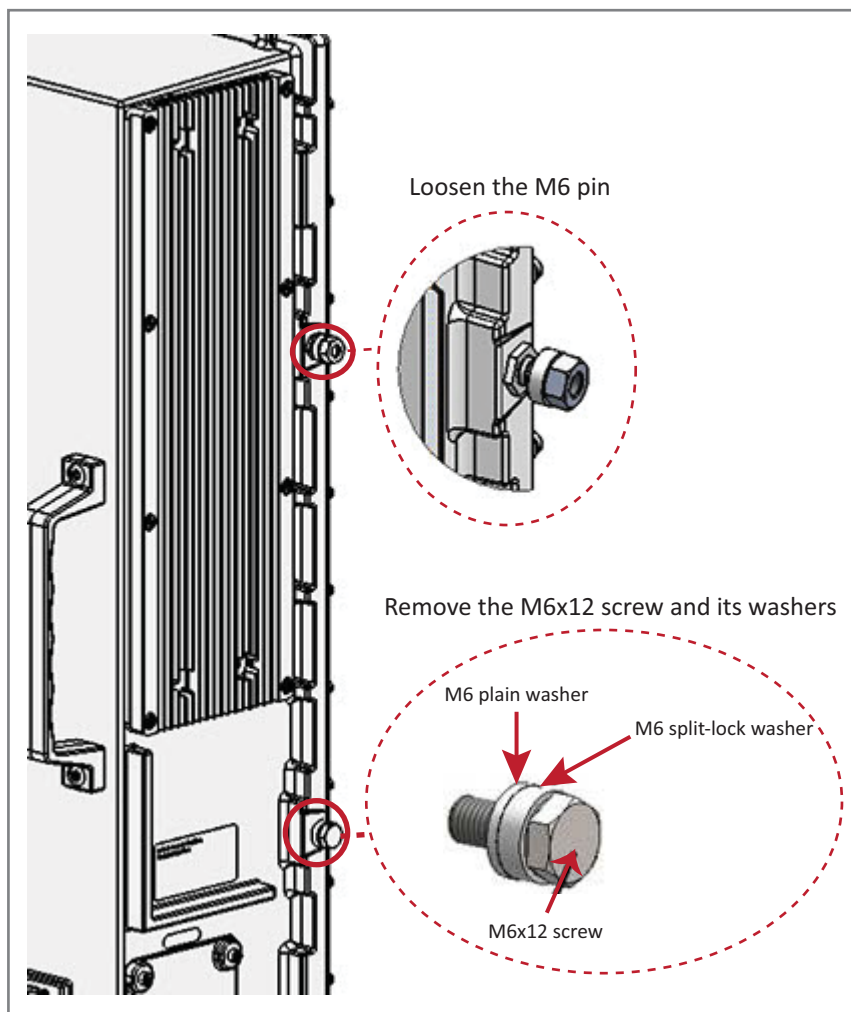

- 8 Use both handles on the CAP M-1 chassis to lift it above the Mounting Bracket, and with the front of the chassis facing the mounting surface, lower it into place.
 - The M6 pins that you loosened in [Step 7 on page 33](#) must align with the Mounting Bracket slots, as shown below.
 - The washer for each M6 pin should be next to the CAP M-1 chassis (inside the bracket).

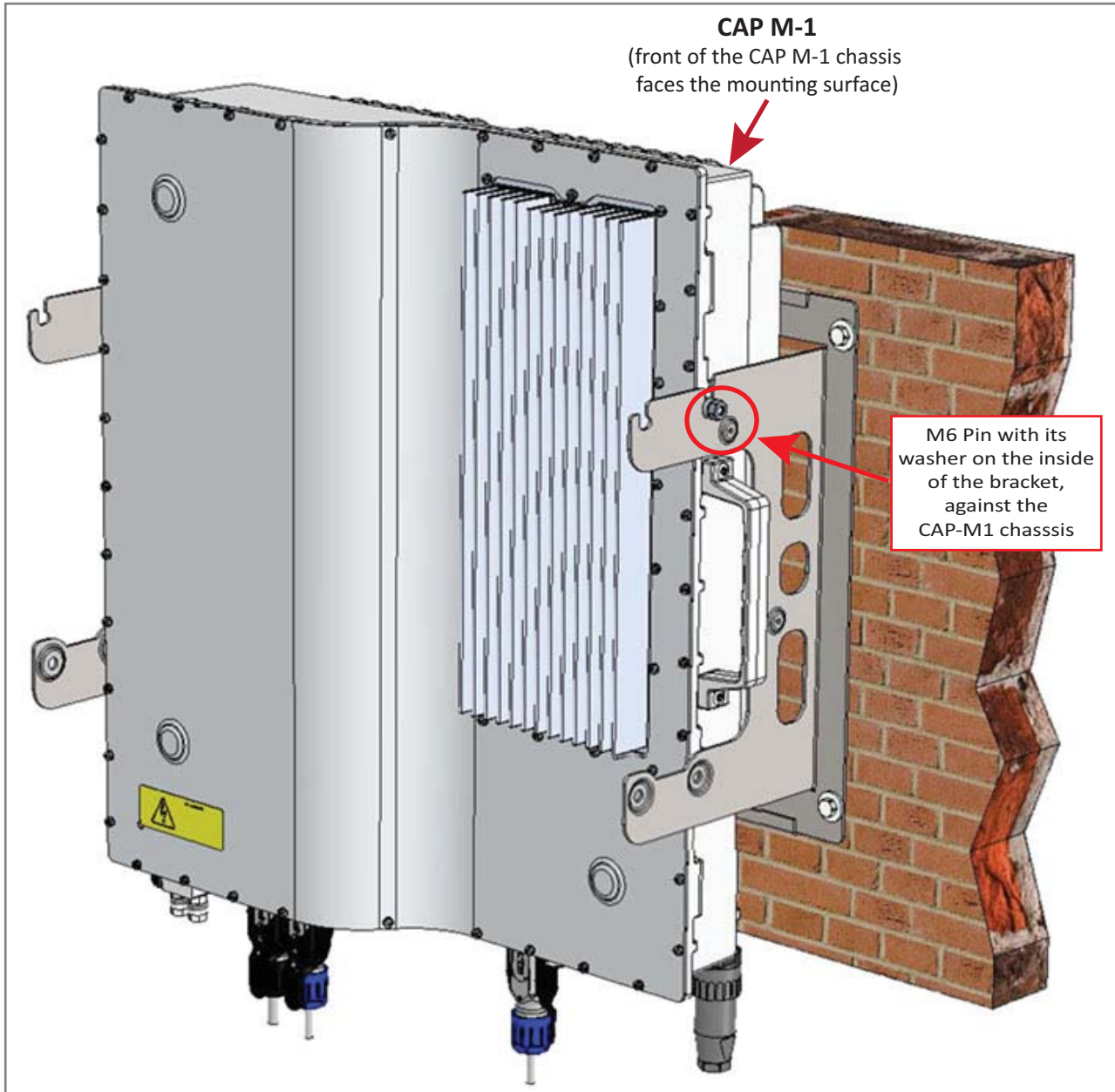

- 9 On the right side of the CAP M-1, torque the M6 pin to 11 N-m.
- 10 Repeat [Step 9](#) on the left side of the CAP M.

- 11 On lower right of the CAP M-1, reinstall the M6x12 screw and its washers that you removed in [Step 7 on page 33](#).
 - a Slide first the M6 split-lock washer and then the M6 plain washer over the M6x12 screw.
 - b Insert the M6x12 screw through the screw hole shown below, and screw it back into the CAP M-1 chassis; torque to 11 N-m.

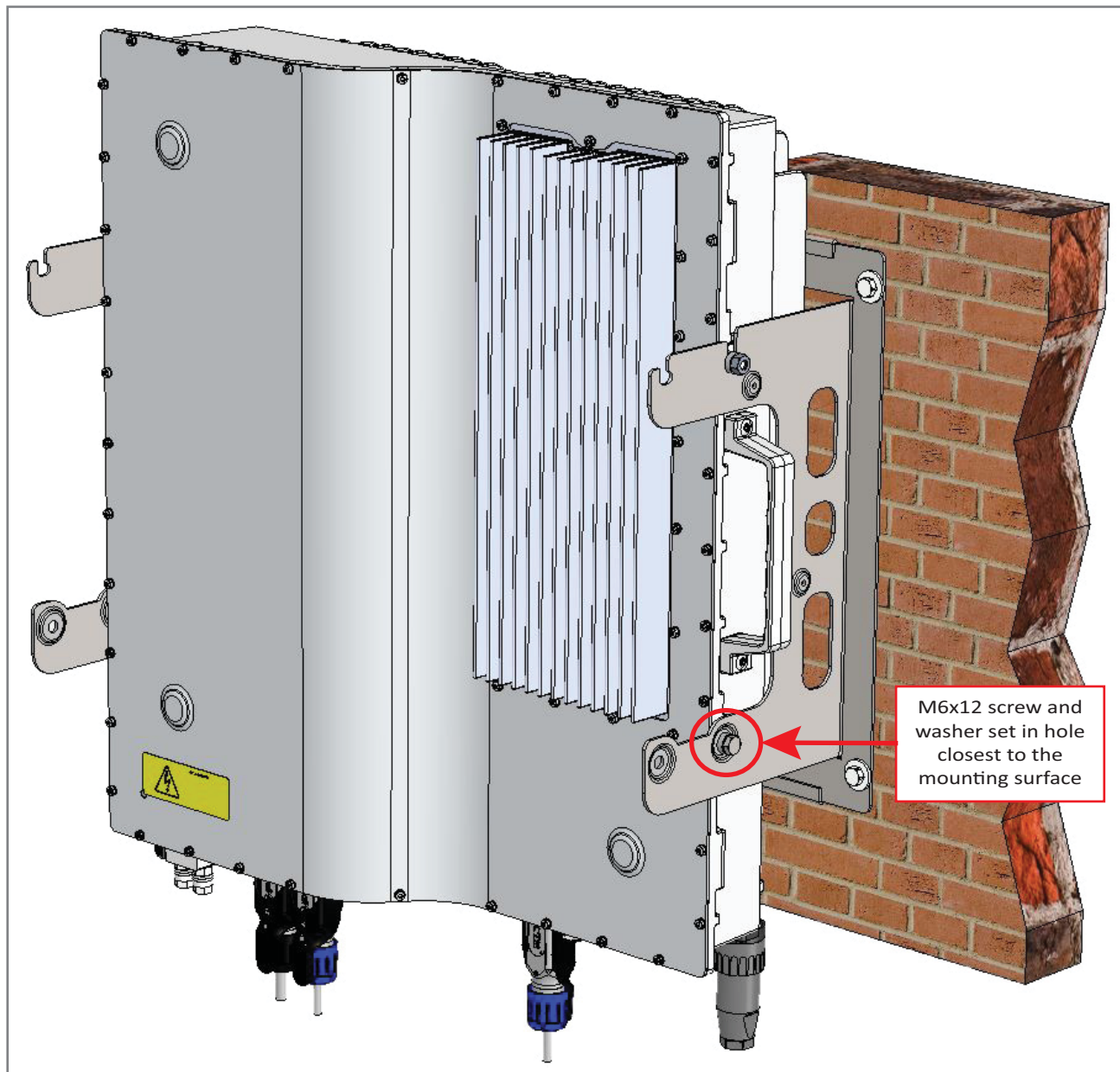

- 12 Repeat [Step 11](#) on the left side of the CAP M-1.

13 From both sides of CAP M-2:

- a** Loosen the M6 pins, leaving its washer in place.
- b** Remove the two M6 screws and their washers; reserve the screws and washers as you will later reinstall them.

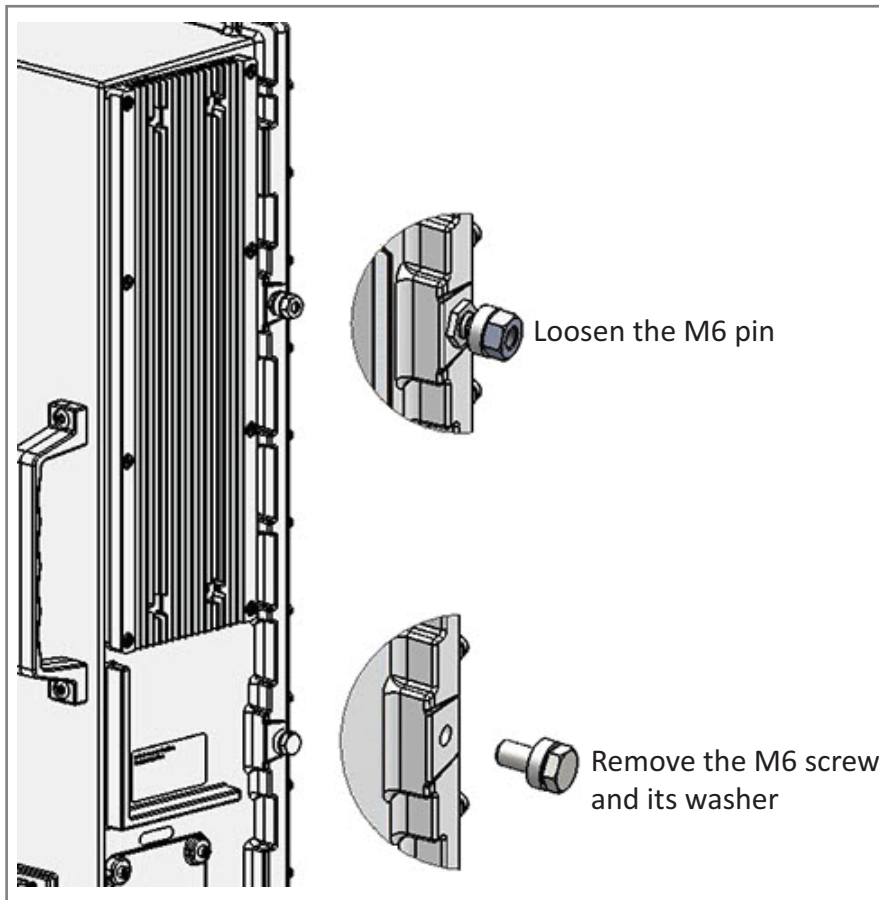

- 14** Use both handles on the CAP M-2 chassis to lift it above the Mounting Bracket with the back of its chassis facing the back of CAP M-1, and then lower it into place.
- The M6 pins that you loosened in [Step 13 on page 36](#) must align with the Mounting Bracket slots, as shown below.
 - The washer for each M6 pin should be next to the CAP M-2 chassis (inside the bracket).

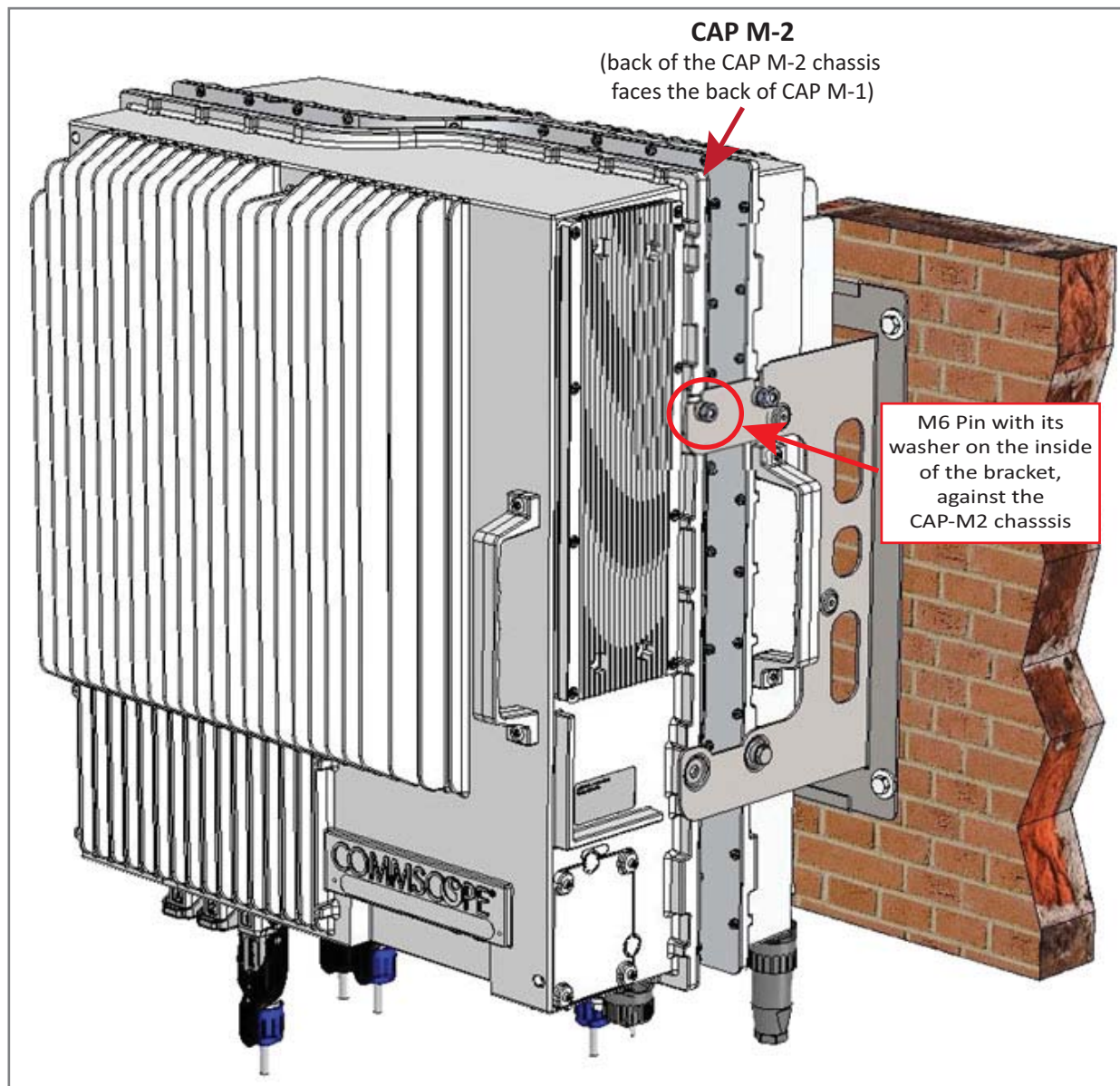

- 15** On the right side of the CAP M-2, torque the M6 pin to 11 N-m.
- 16** Repeat [Step 15](#) on the left side of the CAP M.

- 17 On lower right of the CAP M-2, reinstall the M6x12 screw and its washers that you removed in [Step 13 on page 36](#).
 - a Slide first the M6 split-lock washer and then the M6 plain washer over the M6x12 screw.
 - b Insert the M6x12 screw through the screw hole shown below, and screw it back into the CAP M chassis; torque to 11 N-m.

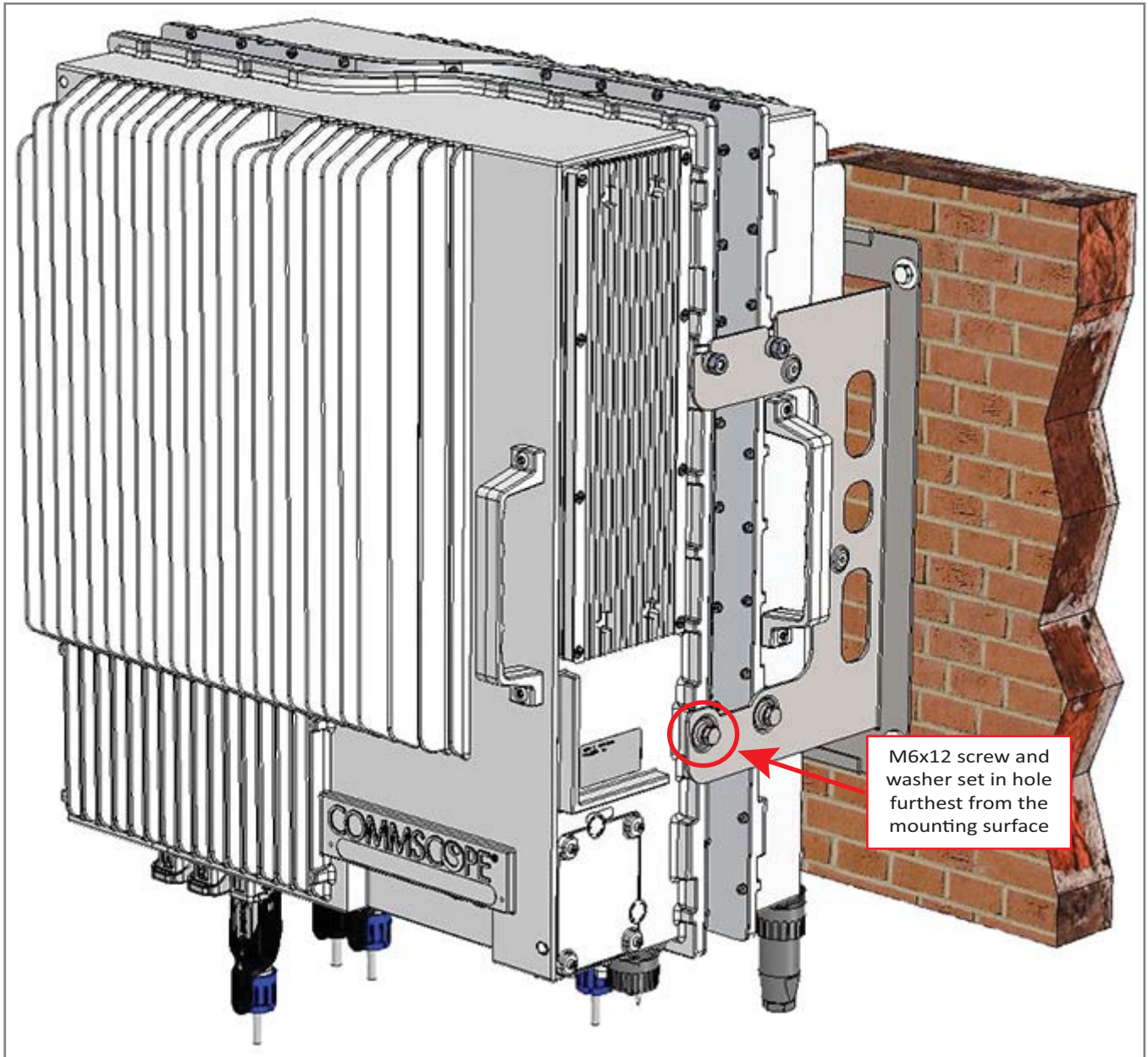

- 18 Repeat [Step 11](#) on the left side of CAP M-2.
- 19 Do one of the following:
 - If this installation requires a Hybrid Fiber Splice Box, go to ["Attach a Hybrid Fiber Splice Box to the CAP M" on page 42](#).
 - If this installation does **not** a Hybrid Fiber Splice Box, go to ["Grounding the CAP M" on page 46](#).

Mount the CAP M to a 4" to 18" Pole

This procedure is specific to the CAP M Pole Mounting Kit for Up to 18" Poles (CommScope PN 7692096-XX), which is used when mounting a CAP M to a pole with a circumference of 4" to 18" (10.2 cm to 45.8 cm).

Figure 8 shows the assembled kit mounted to a pole.

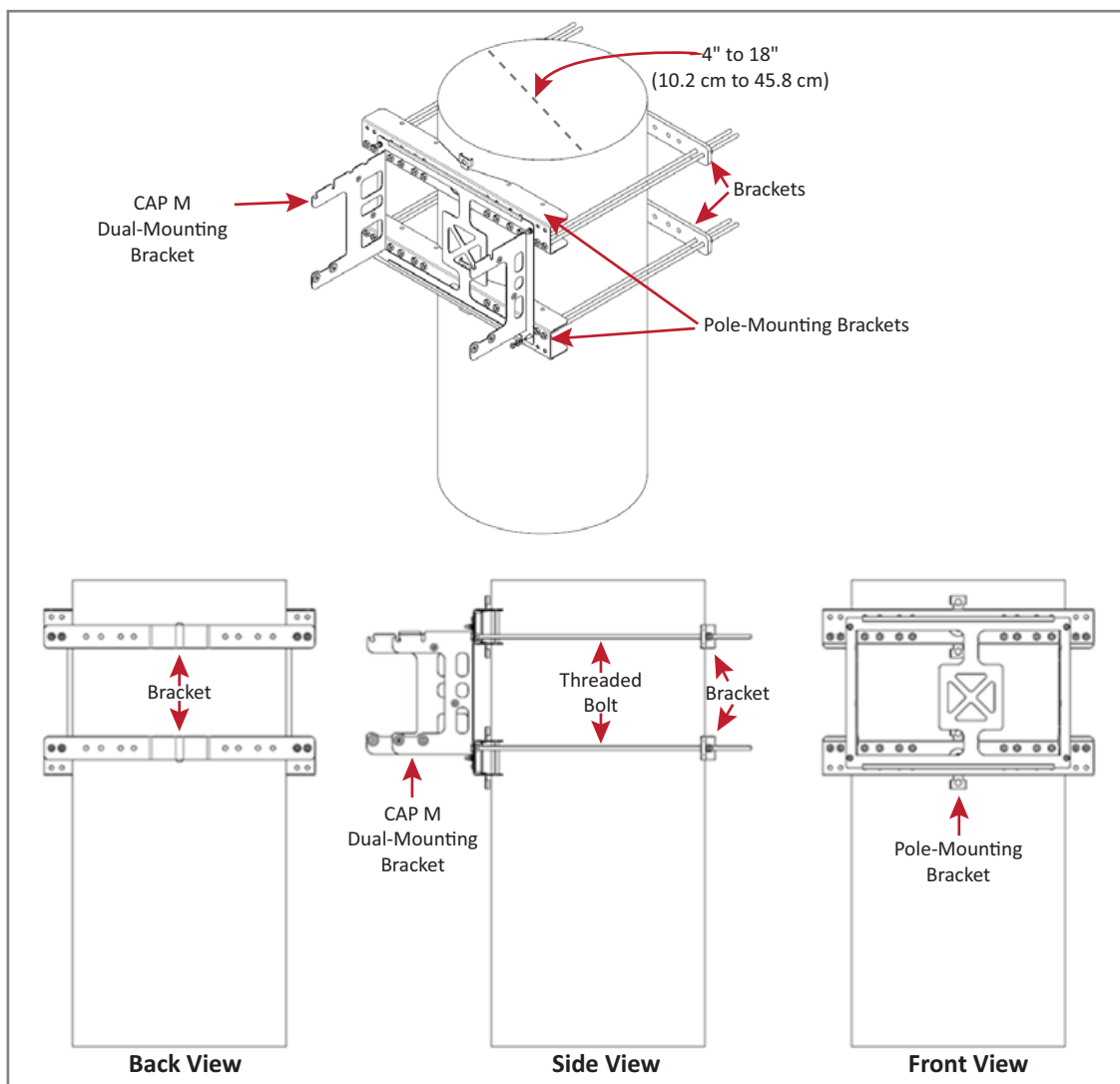

Figure 8. Installation Views of the CAP M Pole Mounting Kit for Up to 18" Poles (CommScope PN 7692096-XX)

Do the following to assemble the CAP M Pole Mounting Kit for Up to 18" Poles, mount the kit to a pole, and then mount the CAP M on the mounting kit.



This procedure requires two installers.

- 1 Obtain the CAP M Pole Mounting Kit for Up to 18" Poles (CommScope PN 7692096-XX).
- 2 Obtain either a Single Mounting Bracket Kit (CommScope PN 7821955-xx) or a Dual Mounting Bracket Kit (CommScope PN 7821954-xx), as required for this installation.

- 3 Follow the steps in ["Unpack and Inspect the CAP M and Optional Accessories"](#) on page 19. Table 9 lists the parts that ship with the CAP M Pole Mounting Kit for Up to 18" Poles.

Table 9. Parts List for CommScope PN 7692096-XX

Description	Quantity	Description	Quantity
Pole-Mounting Bracket	2	M8 Threaded Bolt	8
Bracket	2	M8 Hexagon Nut	8
M6 Hexagon Nut	4	M8 Plain Washer	16
M6 Plain Washer	4	M8 Split-Lock Washer	8
M6 Split-Lock Washer	4	M8 Nut	8

- 4 Refer to ["Determine the Mounting Site"](#) on page 16 to determine the mounting location, which must be able to support the weight and dimensions of the CAP M.



Installer must verify that the mounting surface will safely support the combined load of the electronic equipment and all attached hardware and components.

- 5 Refer to ["Mounting Orientation"](#) on page 24 to determine the mounting orientation of the CAP M.
- 6 Refer to and observe all cautions listed in ["General Mounting Cautions"](#) on page 23.

- 7 Attach either a Single Mounting Bracket (CommScope PN 7821955-xx) or a Dual Mounting Bracket (CommScope PN 7821954-xx) to the two screw pins on one of the two Pole-Mounting Brackets. Attach the M6 nut and washers in the order shown.

- a Slide one M6 plain washer (7A) over each screw pin.
- b Slide one M6 split-lock washer (7B) over each screw pin, next to the M6 plain washer.
- c Secure one M6 Hexagon Nut (7A) to the end of each screw pin, and then torque to 11 N-m.

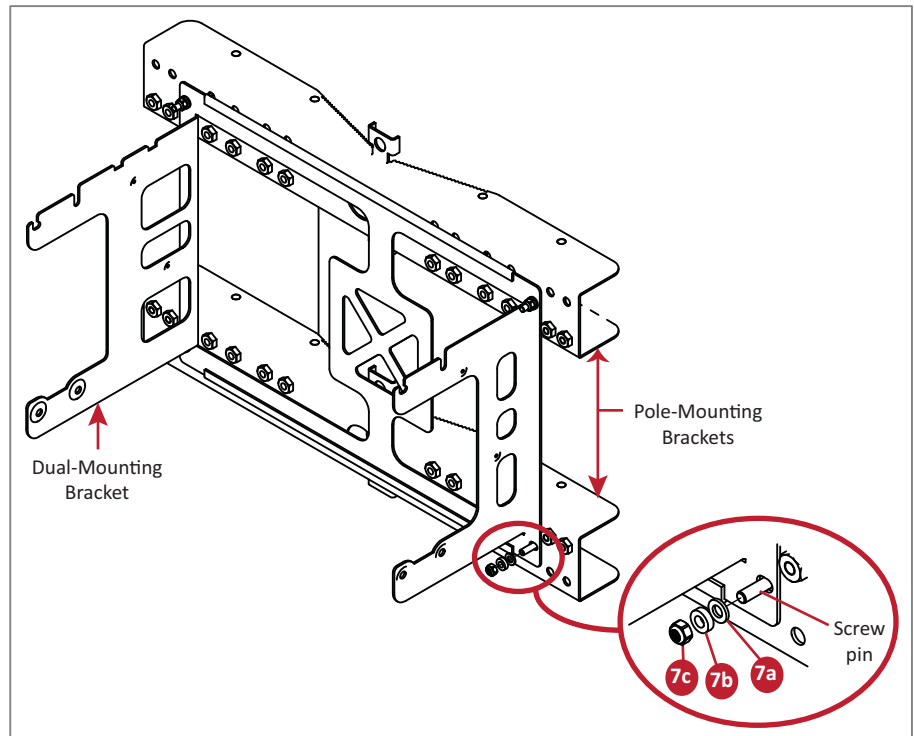

- 8 Repeat [Step 7](#) on the second Pole-Mounting Bracket.



The balance of this procedure may require two installers to complete.

- 9 Attach four of the threaded bolts to the side of the top Pole-Mounting Bracket that will face toward the pole (inside the Pole-Mounting Bracket). Install the M8 nut and washers in the order shown.
 - a Slide one M8 plain washer (9A) to one end of each of the four threaded bolts.
 - b Slide an M8 Hexagon Nut (9B) next to the M8 plain washer.
 - c Torque the M8 Hexagon Nut to 27 N-m.

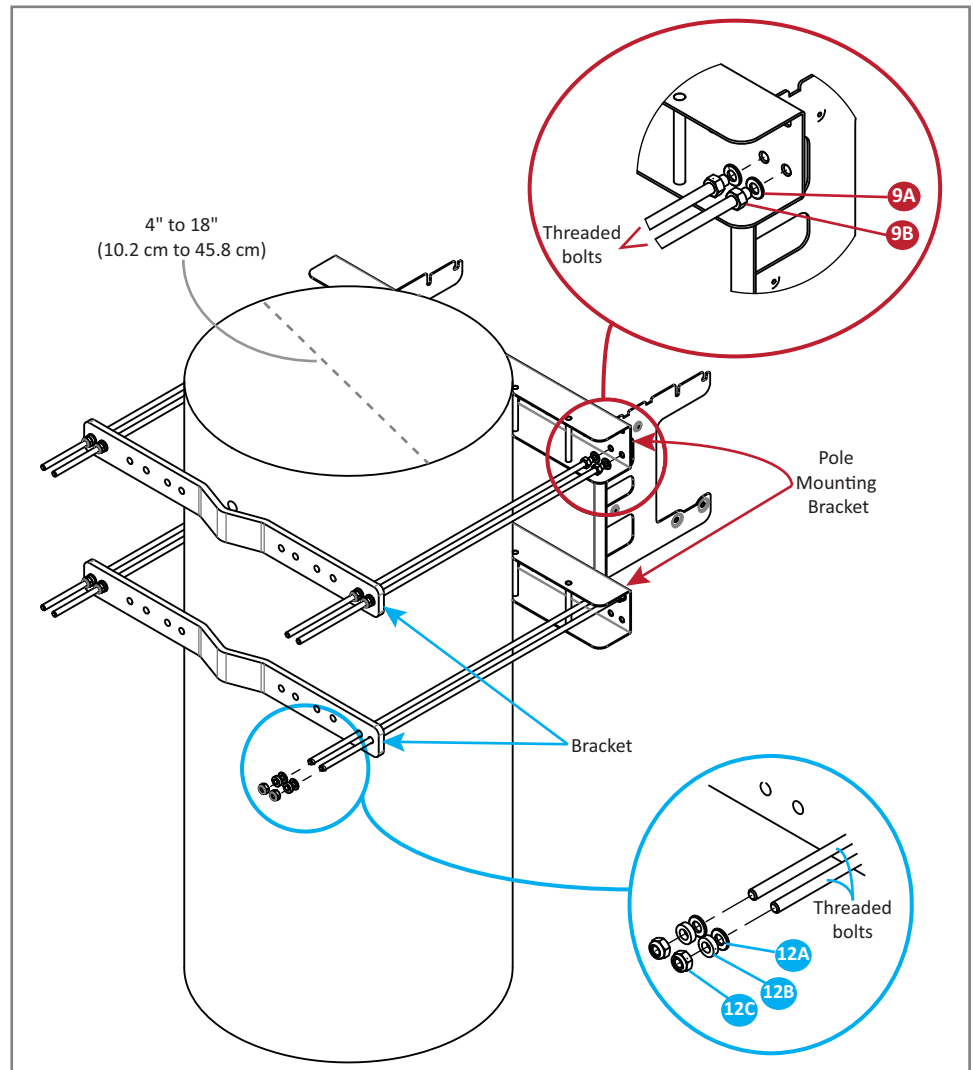

- 10 Repeat [Step 9](#), but this time attach four of the threaded bolts to the bottom Pole-Mounting Bracket.
- 11 One installer should now hold the Pole-Mounting Brackets that you assembled in [Step 7](#) through [Step 10](#) against in the pole at the position at which the CAP M is to be attached to the pole. The eight threaded bolts will protrude to the other side of the pole.
- 12 The second installer should now attach one of the Brackets to the top four threaded bolts that protrude past the pole. Install the M8 nut and washers in the order shown.
 - a Slide one M8 plain washer (12A) to one end of each of the four threaded bolts.
 - b Slide an M8 split-lock washer (12B) next to the M8 plain washer.
 - c Use an M8 nut (12C) to screw the end of the threaded bolts (with the nut and washer) to the welded nuts on the inner side of the top Pole-Mounting Bracket.
 - d Torque the M8 Hexagon Nut to 27 N-m.
- 13 Repeat [Step 12](#), but this time attach the second Bracket to the bottom four threaded bolts.
- 14 To mount the CAP M to the pole-mounting kit, follow the steps in "[Mount a CAP M Using a Single Mounting Bracket](#)" on page 25 or "[Mount Two CAP Ms Using a Dual Mounting Bracket](#)" on page 31, as appropriate for this installation.

Attach a Hybrid Fiber Splice Box to the CAP M



The steps in this section pertain only to those installations that require the use of the optional Hybrid Fiber Splice Box to provide fiber and power to the CAP M. If the optional Hybrid Fiber Splice Box is not required for this installation, skip to "[Grounding the CAP M](#)" on page 46.

Follow the procedure that is appropriate for this installation:

- "[Attaching a Hybrid Fiber Splice Box for a Single Mount Installation](#)" on page 42
- "[Attaching a Hybrid Fiber Splice Box for a Dual Mount Installation](#)" on page 44.

Attaching a Hybrid Fiber Splice Box for a Single Mount Installation

- 1 Hang the Splice Box onto the Single Mounting Bracket on the right-hand side of the CAP M, as shown below.

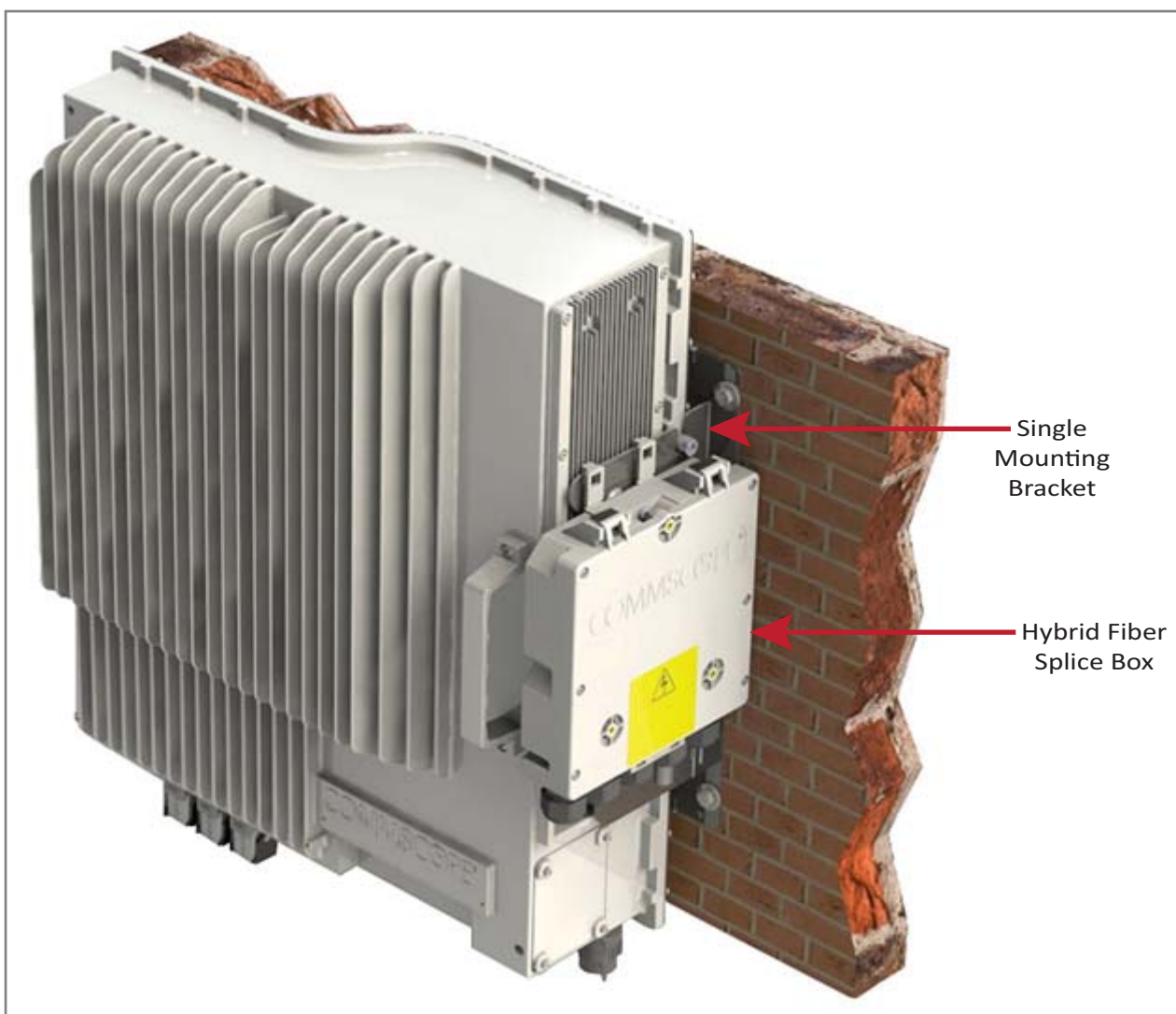

- Remove the six neck screws (shown below) from the front cover of the Splice Box.

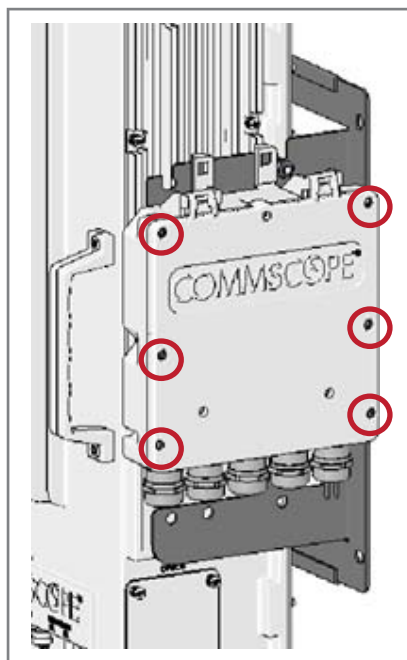

- Open the Splice Box.
- Attach an M4 x 25 pan-head screw to the upper hole, and a second M4 x 25 pan-head to the hole on the lower, right-hand side of the Splice Box.

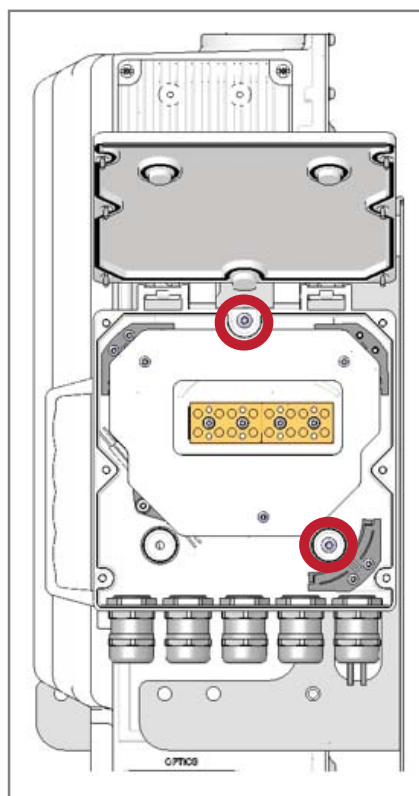

- Close the Splice Box.
- Replace the six neck screws that you removed from the front cover of the Splice Box in [Step 2 on page 43](#).
- Go to "[Grounding the CAP M](#)" on page 46.

Attaching a Hybrid Fiber Splice Box for a Dual Mount Installation

- 1 Break the left-hand side hook of the Splice Box bracket. This is necessary for proper mounting.
- 2 Hang the Splice Box onto the Dual Mounting Bracket on the left-hand side of the CAP M, as shown below.

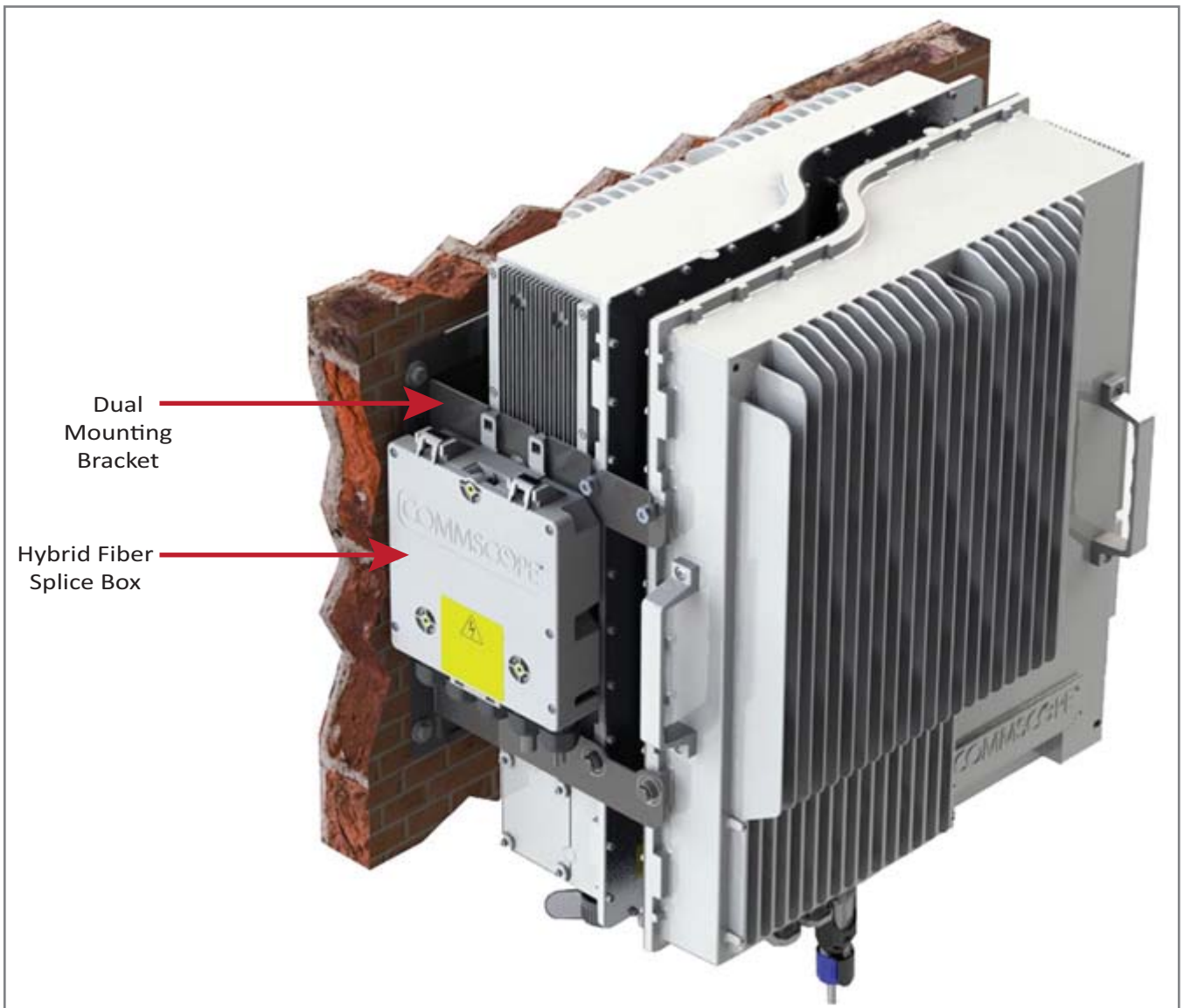

- 3 Remove the six neck screws (shown below) from the front cover of the Splice Box.

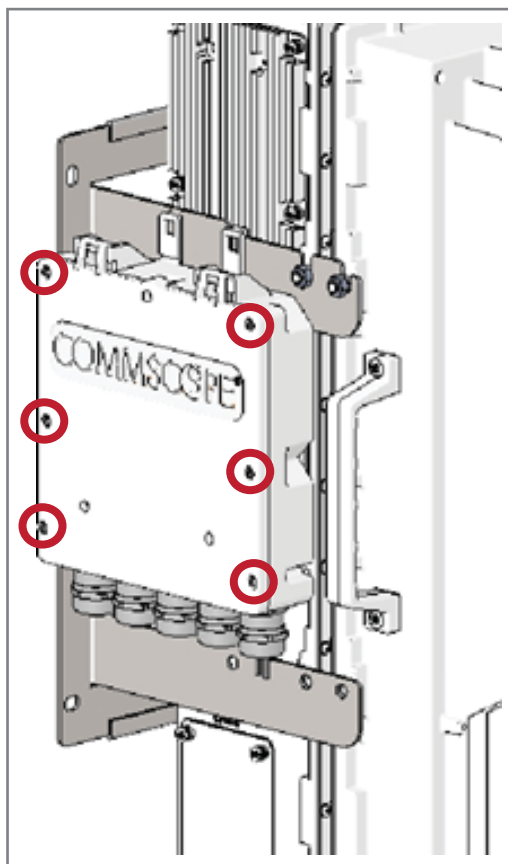

- 4 Open the Splice Box.
- 5 Attach an M4 x 25 pan-head screw to the upper hole, and a second M4 x 25 pan-head to the hole on the lower, left-hand side (shown at right) of the Splice Box.
- 6 Close the Splice Box.
- 7 Replace the six neck screws that you removed from the front cover of the Splice Box in [Step 3 on page 45](#).
- 8 Go to "[Grounding the CAP M](#)" on page 46.

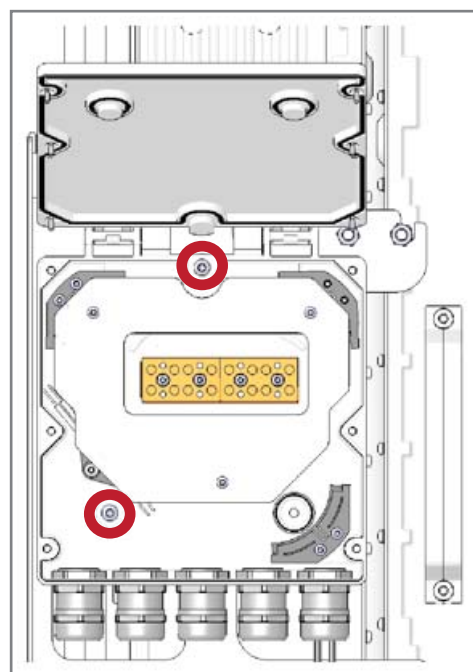

Grounding the CAP M



The CAP M must be grounded.



Do not use the grounding bolts to connect an external device.

- 1 Connect an earth-bonding cable to the grounding bolt connections on the outside of the CAP M chassis, as shown below.



- 2 Loosen the M6 hex nut(s), and then connect the earth-bonding cable between the two washers as shown to the right.
- 3 Secure the earth-bonding cable by tightening the M6 hex nut(s) that you loosened in the preceding step.
- 4 Connect the other end of the earth-bonding cable to a suitable permanent ground per local electrical code practices.
- 5 Follow the steps in ["Connect the CAP M Cables" on page 47](#).

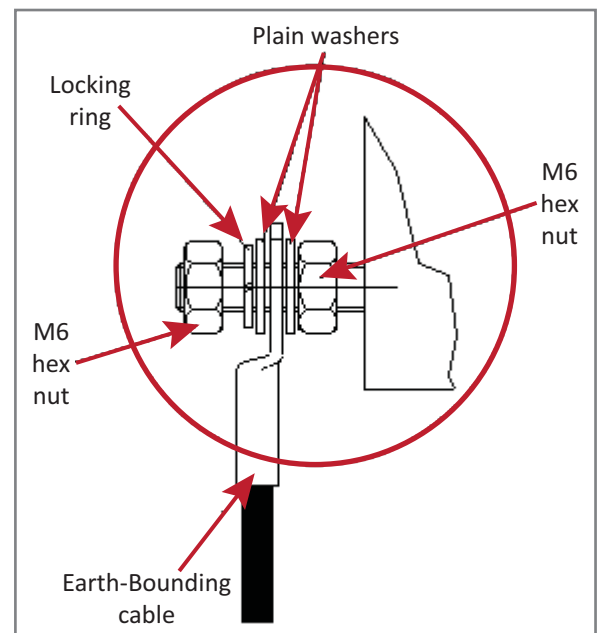

Connect the CAP M Cables

Complete the following procedures in the order in which they are presented. Unless otherwise noted, each procedure is applicable to a singular CAP M (not in a cascade), or to a Primary or Secondary CAP M in a cascade.

- "Obtain the Required Cable Material" on page 47
- "Connect the CAP M to an RF Antenna" on page 48
- "Connect the CAP M to a Classic CAN or TEN" on page 48
- "Connect a Secondary CAP M (Optional)" on page 48
- "Connect an External Ethernet Device (Optional)" on page 49.



Do not remove protective caps from any of the connectors until instructed to do so.

Obtain the Required Cable Material

Contact your local CommScope sales representative to obtain the following components, as required, for this installation.

- Per the installation plan, obtain either Single Mode Fiber (SMF) or Multi Mode Fiber (MMF) that is of sufficient length to reach from the CAP M to the Classic CAN or TEN.
- Obtain at least one Optical OCTIS Kit (PN 7770612). All installations require one Optical OCTIS Kit, which is included in the CAP M shipment. If cascading a Secondary CAP M, a second Optical OCTIS Kit is required.
- Obtain SFP+ Module pairs that are appropriate for this installation. [Table 10](#) identifies the available SFP+ Modules and the maximum range for each.

Table 10. Supported SFP+ Modules

CommScope PN	Description	Maximum Range		Notes
7660511	SFP+, 10GBase-SR, Multi Mode	OM3 300m	OM4 400m	One placed in the TEN and paired with another in the Classic CAN
7680813	SFP+, 10GBase-LR, Single Mode	10km		One placed in the TEN and paired with another in the Classic CAN

- If connecting an external Ethernet device such as WiFi or IP camera, an Ethernet OCTIS Kit (PN 7760652) and appropriate CAT cable for the device.

Connect the CAP M to an RF Antenna

- 1 Obtain 50 Ω coaxial cables that are of sufficient length to reach from the CAP M to the passive antenna. The end of the 50 Ω coaxial cable that will connect to the ANT connector can be either a push-pull connector or a threaded connector.
- 2 Install the passive antennas per the manufacturer's installation instructions.
- 3 Remove the IP67/EMI blank plug from the ANT connector.
- 4 Connect the passive multi-band antenna to the ANT connector using coaxial cable with the least amount of loss possible.
 - If the 50 Ω coaxial cable has a push-pull connector, make sure the cable is seated firmly in the ANT connector.
 - If the 50 Ω coaxial cable has a threaded connector, torque the connector 5 N-m (3.69 ft-lb). Do not over-tighten the connector.
- 5 Connect the other end of the 50 Ω coaxial cable to the passive antenna installed in [Step 2](#).

Connect the CAP M to a Classic CAN or TEN

Connect the CAP M Optical Port 1 as appropriate for this installation. Note the maximum range listed in [Table 10](#).

- 1 Remove the dust cap from the CAP M Optical Port 1 connector and the connectors on the SMF or MMF.
- 2 Follow the local cleaning technique to clean the optical port for each SFP+ Module.
- 3 Clean the connectors on the SMF or MMF following the fiber supplier's recommendations.
- 4 Install the SFP+ connector and Optical OCTIS Kit on the end of the SMF or MMF that will connect to the CAP M, and then connect that end of the fiber to the CAP M Optical Port 1 connector. (Refer to the technical data sheet that ships with the OCTIS Kit for further information.)
- 5 Use the other SFP+ Module to connect the other end of the SMF or MMF to an open port on the OPT Card.



If installing a CAP M with a Hybrid Fiber Splice Box (PN 7693816-xx), the optical fiber will be hanging from the Splice Box.

Connect a Secondary CAP M (Optional)

If appropriate for this installation, connect the Optical Port 2 connector. Note the maximum range listed in [Table 10 on page 47](#).

- 1 Raise the lever on the EMI/IP67 cap on Optical Port 2 connector and remove the cap.
- 2 Remove the caps from the connectors on the SMF or MMF.
- 3 Follow the local cleaning technique to clean the optical port for each SFP+ Module.
- 4 Clean the connectors on the SMF or MMF following the fiber supplier's recommendations.
- 5 Install the SFP+ and Optical OCTIS Kit on the end of the fiber that will connect to the CAP M and connect that end of the SMF or MMF to the CAP M Optical Port 2 connector. (Refer to the technical data sheet that ships with the OCTIS Kit for further information.)
- 6 Use another OCTIS Kit and the other SFP+ Module to connect the other end of the SMF or MMF to Optical Port 1 on the cascaded CAP M.

Connect an External Ethernet Device (Optional)



If you are not connecting an Ethernet device, do not remove the plug from Port A.

If connecting an Ethernet device to a cascaded pair, this must be the Primary Fiber CAP L.

- 1 Read and follow the rules in "[Cat6A Cable Requirements for Ethernet Devices](#)" on page 15.
- 2 Raise the lever on the EMI/IP67 cap on the Port A connector, and then remove the connector's plug.
- 3 Follow the local cleaning technique to clean Port A.
- 4 Install an Ethernet OCTIS Kit on the end of the CAT cable that will connect to the Fiber CAP L, and then connect that end of the cable to Port A on the Fiber CAP L. (Refer to the technical data sheet that ships with the OCTIS Kit for further information.)



Cat6A, including all Cat6A cables, Cat6A Patch Cords, and Patch Panels, between Port A on the Fiber CAP M and an auxiliary Ethernet device cannot exceed 3 meters (9.8 feet).

- 5 Connect the other end of the CAT cable to the Ethernet port of the auxiliary device.
- 6 Go to "[Power the CAP M](#)" on page 49.

Power the CAP M



The CAP M is powered on as soon as power is connected to it. The CAP M must therefore be grounded before you connect any electrical power to it. If you have not completed the steps in "[Grounding the CAP M](#)" on page 46, stop and do so before proceeding.



For the AC power supply connection, a minimum cross section of 1.5 mm² is required and for the DC power supply connection, a minimum cross section of 2.5 mm² is required. Each wire must observe the applicable local regulations regarding loop impedance, voltage drop, and methods of installation. Make sure to connect the correct voltage to the CAP M.

For the CAP M to operate, the Mains power must be connected to the CAP M Mains connector. Either an AC or a DC power cable is delivered with each CAP M—the type of power cable delivered is dependent on the type of power supply in the CAP M.

CAP M AC Power Cable

The AC power cable is a 3.2 m (10.5 ft) 16 AWG cable with a 4-pin Amphenol C016 series plug on one end to connect to the CAP M Mains connector. The other end of the cable is unterminated with 3 end splices to connect to the AC power source. A 10 m (33.7 ft) AC power cable is also available as an option. The AC power cable is shown in [Figure 9](#).

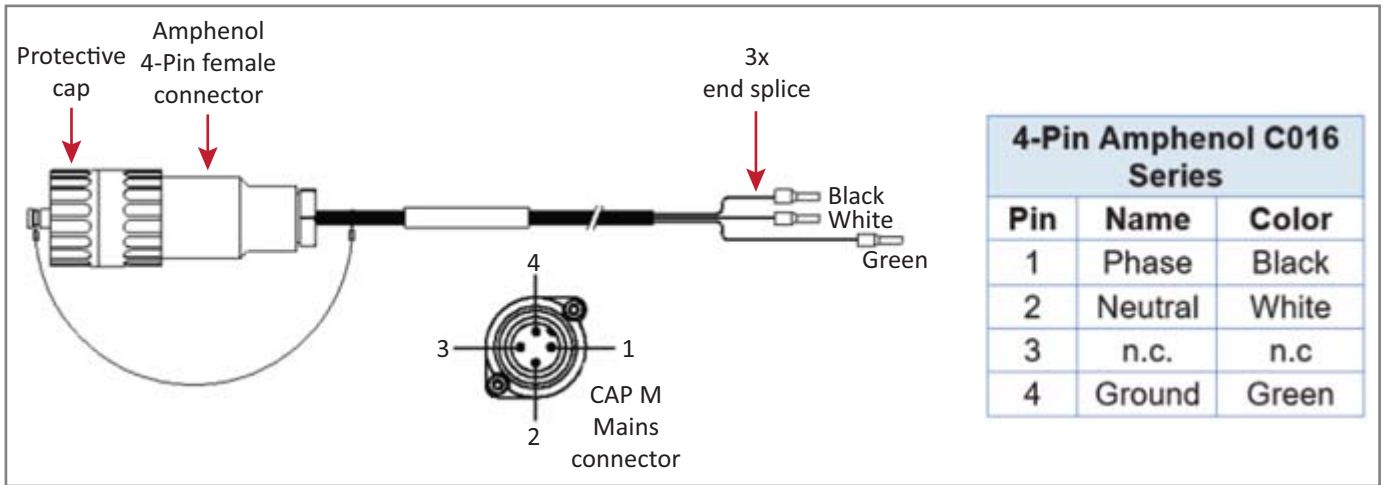

Figure 9. CAP M AC Power Cable

CAP M DC Power Cable

The standard CAP M DC power cable is a 3.2 m (10.5 ft) 13 AWG cable with a 4-pin Amphenol C016 series plug on one end to connect to the CAP M Mains connector. The other end of the cable is unterminated with 2 end splices to connect to the -48 Vdc power source. The standard DC power cable is shown in [Figure 10](#).

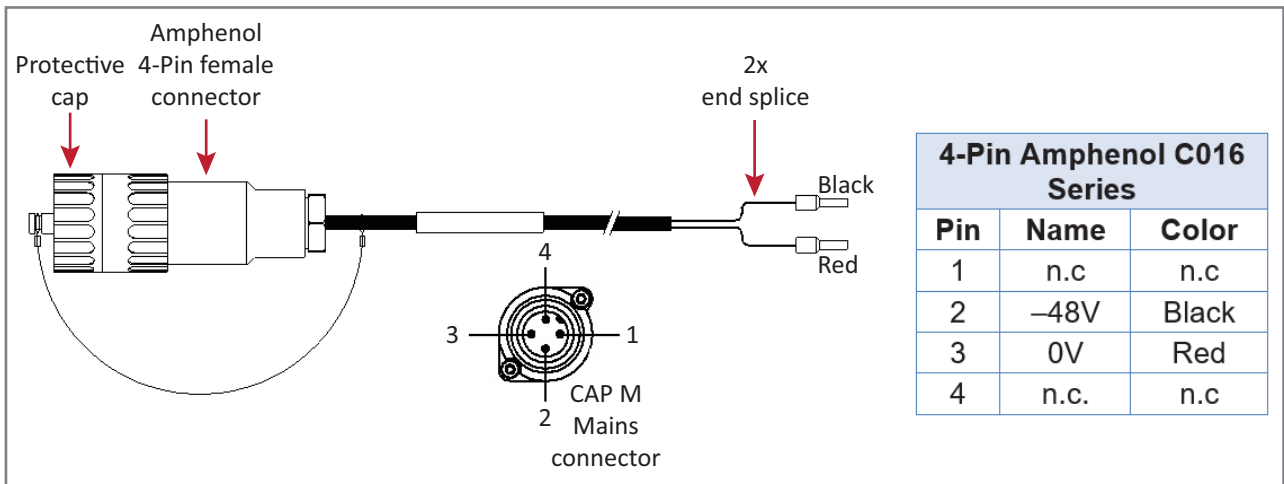

Figure 10. CAP M DC Power Cable

Connect the CAP M Power



Do not connect or disconnect the power cable at the Mains connector while power is on. Turn off Mains power before connecting the power cable at the unit, then, engage mains power again.

Connect the Power connector as appropriate for this installation:

- ["Connect the Mains Power to the CAP M" on page 51](#)
- ["Connect a Hybrid Fiber Splice Box" on page 52.](#)

Connect the Mains Power to the CAP M

- 1 Locate the Mains power cable that was delivered with the CAP M.
- 2 Locate or install a suitable power junction box or receptacle near the unit and route the power cable from the power source to the CAP M.



Do not connect the cable to the unit's Mains connector at this time. The power source must be interruptible.



The Mains cable must be properly secured observing local regulations and electrical codes. Be sure to allow enough slack in the cable at the CAP M to plug or unplug the cable into the Mains connector.

- 3 Dependent on the type of power supply used by the unit, wire the power cable to the junction box or receptacle. Refer to the color code and pin numbers shown in:
 - [Figure 9 on page 50](#) for the AC power cable
 - [Figure 10 on page 50](#) for the DC power cable.
- 4 With the cable's Mains plug disconnected from the CAP M, turn the circuit breaker on, unscrew the plug's protective cover, and carefully test the plug with a voltmeter to ensure that the voltage and polarity are correct.
- 5 Once the testing has been completed, turn off the circuit breaker.
- 6 Unscrew the protective cover from the Mains connector of the unit.

- 7 Insert the AC or DC power cable into the Mains connector as shown below; tighten the clamping ring until it is hand tight. Do not over-tighten the clamping ring.

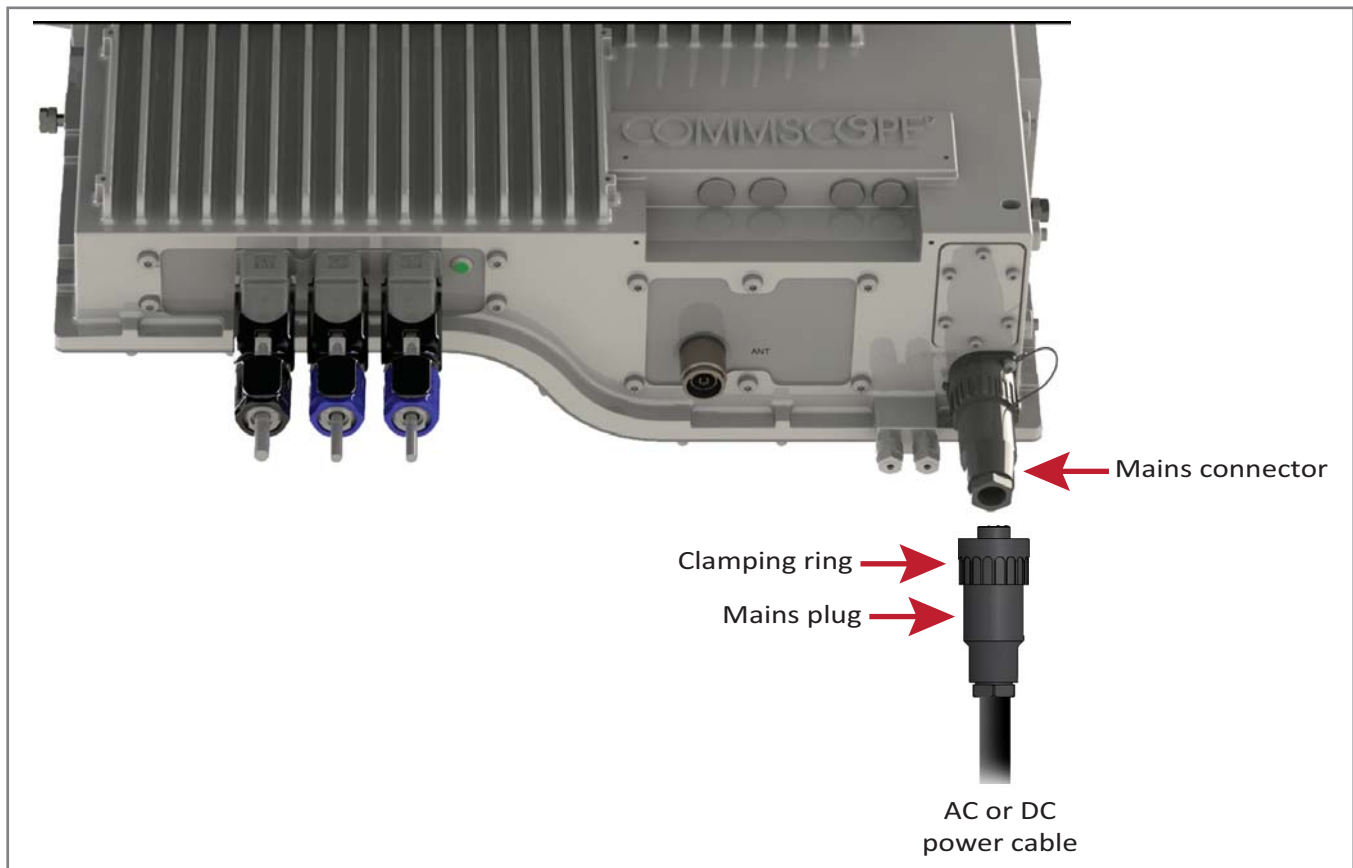

Connect a Hybrid Fiber Splice Box

For a CAP M powered by the Hybrid Fiber Splice Box (PN 7693816-xx) connect the:

- power cable the proprietary 4-pin, 36 to 60 Vdc Power connector on the CAP M, and terminate the other end to the CAP M Hybrid Fiber Splice Box
- LC Fiber Pigtail to the supplied OCTIS connector and splice the other end of the fiber pigtail inside the locally-mounted CAP M Hybrid Fiber Splice Box.

Power the CAP M

The CAP M is powered on as soon as power is connected to it. Under normal operating conditions, the Power LED turns on briefly when the unit is first detected. It will then go out briefly, followed by an initialization period during which the Power LED flashes slowly while the CAP M is configured. The Power LED remains a steady blue (not flashing) once the unit reaches a fully operational state, which typically occurs within 45 seconds.

CAP M Power LED behavior is as follows:

- Off—CAP M is not powered on.
- Steady blue—CAP M is powered on and operational.
- Slow flashing blue—CAP M is powered on and initializing.
- Rapid flashing blue—CAP M Unit Identifier active via the **Flash LED** function in the Era GUI.

CONTACTING COMMSCOPE

The following sections tell you how to contact CommScope for additional information or for assistance.

DCCS Global Technical Support

The following sections tell you how to contact the CommScope Distributed Coverage and Capacity Solutions (DCCS) Technical Support team. Support is available 7 days a week, 24 hours a day.

Telephone Helplines

Use the following Helpline telephone numbers to get live support, 24 hours a day:

- 24x7** +1 888-297-6433 (Toll free for U.S. and Canada)
- EMEA 8:00-17:00 (UTC +1)** + 800 73732837 (Toll free for parts of EMEA and Australia)
+ 49 909969333 (Toll charge incurred)

Calls to an EMEA Helpline outside of the 8:00 to 17:00 time frame will be forwarded to the 24x7 Helpline.

Online Support

To go to the CommScope DCCS Support Request web site from which you can initiate a Technical Support ticket, do one of the following:

- Scan the QR Code to the right.
- If viewing this document online as a PDF, click on the following URL link:
<http://www.commscope.com/wisupport>
- Enter the preceding URL into your web browser, and then press **ENTER** on your keyboard.



Waste Electrical and Electronic Equipment Recycling

Country specific information about collection and recycling arrangements per the Waste Electrical and Electronic Equipment (WEEE) Directive and implementing regulations is available on CommScope's website.

To access information on the CommScope recycling program, do any of the following:

- Scan the QR Code to the right.
- If viewing this document online as a PDF, click on the following URL link:
<http://www.commscope.com/About-Us/Corporate-Responsibility-and-Sustainability/Environment/Recycling/>
- Enter the preceding URL into your web browser, and then press **ENTER** on your keyboard.



Hardware to Software Mapping Information

- 1 Scan the QR Code to the right to view or download the minimum software requirements for each of the DCCS hardware modules. Alternatively, you can go to the following web address to access the portal:



http://www.commscope.com/collateral/DCCS_HW_SW_Mapping/

- 2 Click on a document link to open it, or right click on the link and select the **Save target as...** option from the contextual menu.

DCCS Technical Training

- 1 To access training on the online CommScope DAS and Small Cell Institute, do one of the following:
 - Scan the QR Code to the right.
 - If viewing this document online as a PDF, click on the following URL link.
<http://www.commscopetraining.com/courses/dassc/>
 - Enter the preceding URL into your web browser, and then press **ENTER** on your keyboard.
- 2 Review the courses listed in separate course panels; for further information on a course, click its **Full details** button. Instructor-led courses are conducted in North America and Europe. Before choosing a course, please verify the region.
- 3 To view the course schedule and register, click **Course Registration** at the top of the course page; this opens the **Partner Learning Center Login** page.
 - If you have an account, enter your **Username** and **Password**, and then click **Login**. (Click on the **Reset Password** link if you do not have your login information.)
 - If you don't have an account, click on the **Create New User Account** link under the **Login** button, and follow the prompts.



Once you have logged in, you will see a list of available class dates.

- 4 Click the date you prefer and select the **Enroll** or **Register Now** button to enroll. Follow the prompts through the payment process.
- 5 Click either the **Available Training** or **Calendar** tab to view other training courses.

For training related questions, please contact the CommScope DAS and Small Cell Institute at one of the following emails, as appropriate for your location:

Americas: DASTrainingUS@CommScope.com

EMEA: DASTrainingEMEA@CommScope.com

Accessing Era User Documentation

- 1 Scan the QR Code to the right to go directly to the CommScope DCCS Customer Portal, where you can access the DCCS user documentation.



Alternatively, you can go to the following web address to access the portal:

www.mycommscope.com

- 2 Access to the Customer Portal requires a user account and password. On the Sign In page, do one of the following:
 - If you have an account, enter your Email address and Password, and then click Sign In.
 - If you don't have an account, click New user registration, and follow the prompts.
- 3 Click DCCS to open the site.
- 4 Select your site, and then click on a product link to open the product page.
- 5 Click on the title of any document to open it.

