



ECL-TA Test Report No.: 20-020

Designation:	CAP H 80-85_17E_19_26 F-AC-F1-APE, Band 5
Manufacturer:	Andrew
Serial No(s):	BGCHIA2043001
ID No.	7841153-0001
Test Specification(s):	ANSI 63.26:2015 FCC Rules and Regulations as listed in 47 CFR, Part 20:2019-10-01
Test Plan:	Measurement of Band 5, downlink.
Test Result:	Passed

Date of issue:	2021-01-27		Signature:
Version:	01	Technical	
Date of delivery:	2020-12	Reviewer:	
Performance date:	2020-12-14. – 2021-01-07	Report Reviewer:	



Deutsche
Akkreditierungsstelle
D-PL-12024-06-02

The test results relates only to the tested item. The sample has been provided by the client.
Without the written consent of Bureau Veritas Consumer Products Services Germany GmbH excerpts of this report shall not be reproduced.

Bureau Veritas
Consumer Products Services Germany GmbH
www.bureauveritas.de/cps
Phone: +49 (0)40 – 740 41 – 0

Schwerin
Wilhelm-Hennemann-Str. 8, 19061 Schwerin
cps-schwerin@de.bureauveritas.com

Tuerkheim
Businesspark A96, 86842 Tuerkheim
cps-tuerkheim@de.bureauveritas.com

Managing Directors: Sebastian Doose, Stefan Kischka
Reg.No.: Schwerin HRB 3564

Hamburg
Oehleckerring 40, 22419 Hamburg
cps-hamburg@de.bureauveritas.com

Nuremberg
Thurn-und-Taxis-Str. 18, 90411 Nuremberg
cps-nuernberg@de.bureauveritas.com



**BUREAU
VERITAS**

ECL-TA-20-020-V01.00

TA tests on Andrew, CAP H 80-85_17E_19_26 F-AC-
F1-APE, Band 5

Commscope

Client:

Andrew Wireless System GmbH

Industriering 10

86675 Buchdorf Germany

Test Laboratory:

Bureau Veritas Consumer Products Services Germany GmbH

Thurn-und-Taxis-Straße 18

D-90411 Nürnberg

Tel.: +49 40 74041 0

Fax: +49 40 74041-2755

Versions management:

V01.00

Initial release



ECL-TA-20-020-V01.00

TA tests on Andrew, CAP H 80-85_17E_19_26 F-AC-
F1-APE, Band 5

Table of Contents

1	APPLIED STANDARDS AND TEST SUMMARY	4
1.1	APPLIED STANDARDS	4
1.2	FCC-ISED CORRELATION TABLE.....	5
1.3	MEASUREMENT SUMMARY/SIGNATURES	6
2	ADMINISTRATIVE DATA	9
2.1	TESTING LABORATORY.....	9
2.2	APPLICANT DATA	9
2.3	MANUFACTURER DATA	9
3	TEST OBJECT DATA.....	10
3.1	GENERAL EUT DESCRIPTION	10
3.2	EUT MAIN COMPONENTS	11
3.3	ANCILLARY EQUIPMENT	11
3.4	AUXILIARY EQUIPMENT.....	12
3.5	EUT SETUPS.....	13
3.6	PRODUCT LABELLING.....	14
4	TEST RESULTS	15
4.1	EFFECTIVE RADIATED POWER, MEAN OUTPUT POWER AND ZONE ENHANCER GAIN 15	
4.2	PEAK TO AVERAGE RATIO	24
4.3	OCCUPIED BANDWIDTH/INPUT-VERSUS-OUTPUT SPECTRUM.....	28
4.4	CONDUCTED SPURIOUS EMISSIONS AT ANTENNA TERMINALS.....	35
4.5	OUT-OF-BAND EMISSION LIMITS	43
4.6	OUT-OF-BAND REJECTION.....	55
4.7	FIELD STRENGTH OF SPURIOUS RADIATION.....	57
5	TEST EQUIPMENT.....	66
6	ANTENNA FACTORS, CABLE LOSS AND SAMPLE CALCULATIONS	67
6.1	ANTENNA CHASE CBL 6111C (30 MHZ – 1 GHZ)	67
6.2	ANTENNA ROHDE & SCHWARZ HL 025 (1 GHZ – 18 GHZ)	68
7	MEASUREMENT UNCERTAINTIES.....	69
	ANNEX A: ACCREDITATION CERTIFICATE (FOR INFORMATION).....	70
	ANNEX B: ADDITIONAL INFORMATION PROVIDED BY CLIENT	71
	ANNEX C: PHOTO REPORT	1



**BUREAU
VERITAS**

ECL-TA-20-020-V01.00

TA tests on Andrew, CAP H 80-85_17E_19_26 F-AC-
F1-APE, Band 5

1 APPLIED STANDARDS AND TEST SUMMARY

1.1 APPLIED STANDARDS

Type of Authorization

Certification for an Industrial Signal Booster.

Applicable FCC Rules

Prepared in accordance with the requirements of FCC Rules and Regulations as listed in 47 CFR Ch.1 Parts 2, 20 and 22. The following subparts are applicable to the results in this test report.

Part 2, Subpart J - Equipment Authorization Procedures, Certification

Part 20, Commercial Mobile Services

§ 20.21 Signal Boosters

Part 22, Subpart H – Cellular Radiotelephone Service

§ 22.905 – Channels for cellular service

§ 22.913 – Effective radiated power limits

§ 22.917 – Emission limitations for cellular equipment

The tests were selected and performed with reference to:

- FCC Public Notice 935210 applying "Signal Boosters Basic Certification Requirements" 935210 D02, 2019-15-04.
- FCC Public Notice 935210 applying "Measurement guidance for industrial and non-consumer signal booster, repeater and amplifier devices" 935210 D05, 2019-04-03.
- FCC Public Notice 971168 applying "Measurement guidance for certification of licensed digital transmitters" 971168 D01, 2019-04-09.
- ANSI C63.26: 2015



ECL-TA-20-020-V01.00

TA tests on Andrew, CAP H 80-85_17E_19_26 F-AC-
F1-APE, Band 5

Summary Test Results:

The EUT complies with all performed tests as listed in chapter 1.3 Measurement Summary/Signatures.

1.2 FCC-ISED CORRELATION TABLE

**Correlation of measurement requirements for
Industrial Signal Booster from FCC and ISED Canada**

Measurement	FCC reference	ISED reference
Effective radiated power, mean output power and zone enhancer gain	§ 2.1046 § 22.913 KDB 935210 D05 v01r04: 3.5	RSS-GEN Issue 5, 6.12 RSS-131 Issue 3: 5.2.3 RSS-132 Issue 3, 5.4 SRSP-503, Issue 7, 5.1.1
Peak to Average Ratio	§ 22.913	RSS-132 Issue 3, 5.4
Occupied bandwidth Input-versus-output spectrum	§ 2.1049 KDB 935210 D05 v01r04: 3.4	RSS-GEN Issue 5, 6.7 RSS-131 Issue 3: 5.2.2
Conducted spurious Emission at Antenna Terminal	§ 2.1051 § 22.917 KDB 935210 D05 v01r04: 3.6	RSS-GEN Issue 5, 6.13 RSS-132 Issue 3, 5.5
Out-of-band emissions limits	§ 2.1051 § 22.917 KDB 935210 D05 v01r04: 3.6	RSS-GEN Issue 5, 6.13 RSS-132 Issue 3, 5.5
Frequency stability	§ 2.1055 § 22.355	RSS-GEN Issue 5, 6.11 RSS-131 Issue 3: 5.2.4 RSS-132 Issue 3, 5.3
Field strength of spurious radiation	§ 2.1053 § 22.917	RSS-GEN Issue 5, 6.13 RSS-132 Issue 3, 5.5
Out-of-band rejection	KDB 935210 D05 v01r04: 3.3	RSS-131 Issue 3: 5.2.1
All measurements	ANSI 63.26	ANSI 63.26

The test case frequency stability was not performed since the EUT is not equipped with signal processing capabilities. According KDB 935210 D05 in this case a measurement is not required.



ECL-TA-20-020-V01.00

TA tests on Andrew, CAP H 80-85_17E_19_26 F-AC-F1-APE, Band 5

1.3 MEASUREMENT SUMMARY/SIGNATURES

Downlink frequencies: 869 MHz to 894 MHz

47 CFR CHAPTER I FCC PART 22 Subpart H [Base § 2.1046, § 22.913 Stations/Repeater]

Effective Radiated Power, mean output power and zone enhancer gain
The measurement was performed according to ANSI C63.26, KDB 935210 D05 v01r04: 3.5

Final Result

OP-Mode

Frequency Band, Direction, Input Power, Signal Type
BAND 5, RF downlink, 0.3 dB < AGC, Narrowband
BAND 5, RF downlink, 0.3 dB < AGC, Wideband
BAND 5, RF downlink, 3 dB > AGC, Narrowband
BAND 5, RF downlink, 3 dB > AGC, Wideband

Table with 2 columns: FCC, IC. All entries are 'Passed'.

47 CFR CHAPTER I FCC PART 22 Subpart H [Base § 22.913 Stations/Repeater]

Peak to Average Ratio
The measurement was performed according to ANSI C63.26

Final Result

OP-Mode

Frequency Band, Direction, Input Power, Signal Type
BAND 5, RF downlink, 0.3 dB < AGC, Narrowband
BAND 5, RF downlink, 0.3 dB < AGC, Wideband
BAND 5, RF downlink, 3 dB > AGC, Narrowband
BAND 5, RF downlink, 3 dB > AGC, Wideband

Table with 2 columns: FCC, IC. All entries are 'Passed'.

47 CFR CHAPTER I FCC PART 22 Subpart H [Base § 2.1049 Stations/Repeater]

Occupied Bandwidth/Input-versus-output Spectrum
The measurement was performed according to ANSI C63.26, KDB 935210 D05 v01r04: 3.4

Final Result

OP-Mode

Frequency Band, Direction, Input Power, Signal Type
BAND 5, RF downlink, 0.3 dB < AGC, Narrowband
BAND 5, RF downlink, 0.3 dB < AGC, Wideband
BAND 5, RF downlink, 3 dB > AGC, Narrowband
BAND 5, RF downlink, 3 dB > AGC, Wideband

Table with 2 columns: FCC, IC. All entries are 'Passed'.



ECL-TA-20-020-V01.00

TA tests on Andrew, CAP H 80-85_17E_19_26 F-AC-F1-APE, Band 5

47 CFR CHAPTER I FCC PART 22 Subpart H [Base § 2.1051, § 22.917 Stations/Repeater]

Conducted spurious emissions at antenna terminals
The measurement was performed according to ANSI C63.26

Final Result

OP-Mode

Frequency Band, Direction, Input Power, Signal Type

Table with 3 columns: Test Description, FCC, IC. Rows include BAND 5, RF downlink, 0.3 dB < AGC, Narrowband; BAND 5, RF downlink, 0.3 dB < AGC, Wideband; BAND 5, RF downlink, 3 dB > AGC, Narrowband; BAND 5, RF downlink, 3 dB > AGC, Wideband.

47 CFR CHAPTER I FCC PART 22 Subpart H [Base § 2.1051, § 22.917 Stations/Repeater]

Out-of-band emission limits
The measurement was performed according to ANSI C63.26, KDB 935210 D05 v01r04: 3.6

Final Result

OP-Mode

Band Edge, Frequency Band, Number of signals, Direction, Input Power, Signal Type

Table with 3 columns: Test Description, FCC, IC. Rows include Lower, BAND 5, 1, RF downlink, 0.3 dB < AGC, Narrowband; Lower, BAND 5, 1, RF downlink, 0.3 dB < AGC, Wideband; Lower, BAND 5, 1, RF downlink, 3 dB > AGC, Narrowband; Lower, BAND 5, 1, RF downlink, 3 dB > AGC, Wideband; Lower, BAND 5, 2, RF downlink, 0.3 dB < AGC, Narrowband; Lower, BAND 5, 2, RF downlink, 0.3 dB < AGC, Wideband; Lower, BAND 5, 2, RF downlink, 3 dB > AGC, Narrowband; Lower, BAND 5, 2, RF downlink, 3 dB > AGC, Wideband; Upper, BAND 5, 1, RF downlink, 0.3 dB < AGC, Narrowband; Upper, BAND 5, 1, RF downlink, 0.3 dB < AGC, Wideband; Upper, BAND 5, 1, RF downlink, 3 dB > AGC, Narrowband; Upper, BAND 5, 1, RF downlink, 3 dB > AGC, Wideband; Upper, BAND 5, 2, RF downlink, 0.3 dB < AGC, Narrowband; Upper, BAND 5, 2, RF downlink, 0.3 dB < AGC, Wideband; Upper, BAND 5, 2, RF downlink, 3 dB > AGC, Narrowband; Upper, BAND 5, 2, RF downlink, 3 dB > AGC, Wideband.



ECL-TA-20-020-V01.00

TA tests on Andrew, CAP H 80-85_17E_19_26 F-AC-
F1-APE, Band 5

**47 CFR CHAPTER I FCC PART 22 Subpart H [Base KDB 935210 D05 v01r04: 3.3
Stations/Repeater]**

Out-of-band rejection

The measurement was performed according to ANSI C63.26, 935210
D05 v01r04: 3.3

Final Result

OP-Mode

Frequency Band, Direction

BAND 5, RF downlink

Setup

FCC

IC

Passed

Passed

**47 CFR CHAPTER I FCC PART 22 Subpart H [Base § 2.1053, § 22.917
Stations/Repeater]**

Field strength of spurious radiation

The measurement was performed according to ANSI C63.26

Final Result

OP-Mode

Frequency Band, Test Frequency, Direction

BAND 5, high, RF downlink

BAND 5, low, RF downlink

BAND 5, mid, RF downlink

FCC

IC

Passed

Passed

Passed

Passed

Passed

Passed



**BUREAU
VERITAS**

ECL-TA-20-020-V01.00

TA tests on Andrew, CAP H 80-85_17E_19_26 F-AC-
F1-APE, Band 5

2 ADMINISTRATIVE DATA

2.1 TESTING LABORATORY

Bureau Veritas Consumer Products Services Germany GmbH
Thurn-und-Taxis-Straße 18
D-90411 Nürnberg
Tel.: +49 40 74041 0
Fax: +49 40 74041-2755

2.2 APPLICANT DATA

Company Name: Commscope
Andrew Wireless Systems GmbH

Address: Industriering 10
86675 Buchdorf
Germany

Contact Person: Mr. Frank Futter

2.3 MANUFACTURER DATA

Company Name: Please see applicant data.

Address:



ECL-TA-20-020-V01.00

TA tests on Andrew, CAP H 80-85_17E_19_26 F-AC-
F1-APE, Band 5

3 TEST OBJECT DATA

3.1 GENERAL EUT DESCRIPTION

Kind of Device product description	Cellular Repeater
Product name	Cellular Repeater
Type	
Declared EUT data by the supplier	
General Product Description	The EUT is an industrial signal booster supporting the following: Band 5: downlink: 869 MHz - 894 MHz; uplink: 824 MHz to 849 MHz A RF operation is supported for downlink.
Booster Type	Industrial Signal Booster
Voltage Type	AC/50 Hz - 60 Hz
Voltage Level	100 V - 240 V
Nominal Output Donor Port [Uplink]	-----
Nominal Output Server Port [Downlink]	42.5 dBm
Nominal Gain [Uplink]	-----
Nominal Gain [Downlink]	37.5 dB

The main components of the EUT are listed and described in chapter 3.2 EUT Main components.



ECL-TA-20-020-V01.00

TA tests on Andrew, CAP H 80-85_17E_19_26 F-AC-
F1-APE, Band 5

3.2 EUT MAIN COMPONENTS

Sample Name	FCC-ID	ISED-ID
	XS5-CAPH8171926	2237E-CAPH8171926
Sample Parameter	Value	
Serial Number	BGCHIA2043001	
HW Version	7841153-0001	
SW Version	SW 2.8.2.42	
Comment	-----	

NOTE: The short description is used to simplify the identification of the EUT in this test report.

3.3 ANCILLARY EQUIPMENT

For the purposes of this test report, ancillary equipment is defined as equipment which is used in conjunction with the EUT to provide operational and control features to the EUT. It is necessary to configure the system in a typical fashion, as a customer would normally use it. But nevertheless Ancillary Equipment can influence the test results.

Device	Details (Manufacturer, Type Model, OUT Code)	Description
-	-	-



ECL-TA-20-020-V01.00

TA tests on Andrew, CAP H 80-85_17E_19_26 F-AC-
F1-APE, Band 5

3.4 AUXILIARY EQUIPMENT

For the purposes of this test report, auxiliary equipment is defined as equipment which is used temporarily to enable operational and control features especially used for the tests of the EUT which is not used during normal operation or equipment that is used during the tests in combination with the EUT but is not subject of this test report. It is necessary to configure the system in a typical fashion, as a customer would normally use it. But nevertheless Auxiliary Equipment can influence the test results.

Device	Details (Manufacturer; Type; S/N)	Description
AUX1	Lineage Power; SP800; XK20007	Rack in Conjunction with AUX 2 and AUX 3
AUX2	Cherokee International; CAR1212FPBC-Z;AF09676	Power Supply
AUX 3	Lineage Power; CP2000AC54TEP; CC109167565	Power Supply
AUX4	Commscope; ION-E WCS-2; SZAEAJ1819A0009	Subrack in Conjunction with AUX 5,6. 7, 8 and 9
AUX5	Commscope; ION-E OPT; SZBEAD1722A0035	Optical Card
AUX6	Avago; AFBR 7095MZ 850 nm; AD170230AM1	O/E-Converter
AUX7	Commscope; 7642124-ENG-03; (e1)MA22	LAN System Interface
AUX8	Commscope; ION-E RFD; SZBEAG1825A0002	RF Card
AUX9	Commscope; ION-E RFD; SZBEAG1825A0012	RF Card



ECL-TA-20-020-V01.00

TA tests on Andrew, CAP H 80-85_17E_19_26 F-AC-
F1-APE, Band 5

3.5 EUT SETUPS

This chapter describes the combination of EUTs and equipment used for testing. The rationale for selecting the EUTs, ancillary and auxiliary equipment and interconnecting cables, is to test a representative configuration meeting the requirements of the referenced standards.

Setup	Combination of EUTs	Description and Rationale
		Setup for all tests

OPERATING MODES

This chapter describes the operating modes of the EUT used for testing.

3.5.1 TEST CHANNELS

Band [MHz]	Direction	Lower Frequency Band Edge [MHz]	Upper Frequency Band Edge [MHz]	Center Frequency [MHz]	Output-Port
869 – 894	downlink	869.00	894.00	881.50	ANT



ECL-TA-20-020-V01.00

TA tests on Andrew, CAP H 80-85_17E_19_26 F-AC-F1-APE, Band 5

3.5.2 AUTOMATIC GAIN CONTROL LEVELS

AGC Levels							
Band [MHz]	Direction	Signal Type	AGC Start Pin [dBm]	AGC Start Pin -0.3 dB [dBm]	AGC Start Pin +3 dB [dBm]	Frequency [MHz]	Frequency
869 – 894	Downlink	Narrowband	5.6	5.3	8.6	881.50	Mid
869 – 894	Downlink	Wideband	6.0	5.7	9.0	881.50	
869 – 894	Downlink	Narrowband	6.2	5.9	9.2	869.20	Low
869 – 894	Downlink	Wideband	6.4	6.1	9.4	871.50	
869 – 894	Downlink	Narrowband	5.4	5.1	8.4	893.80	High
869 – 894	Downlink	Wideband	6.2	5.9	9.2	891.50	
869 – 894	Downlink	Narrowband	5.6	5.3	8.6	882.84	Max.Power
869 – 894	Downlink	Wideband	6.2	5.9	9.2	882.84	

Remark:

If the measured frequency f0 for the max power has a too low distance to the band edges, because in the tests modulated signals must be used: The next possible frequency to the according band edge is used.

For example for minimum distances to the band edges:

GSM-Signal (narrowband): 0.2 MHz

AWGN-signal (wideband): 2.5 MHz

3.6 PRODUCT LABELLING

3.6.1 FCC ID LABEL

Please refer to the documentation of the applicant.

3.6.2 LOCATION OF THE LABEL ON THE EUT

Please refer to the documentation of the applicant.

ECL-TA-20-020-V01.00

TA tests on Andrew, CAP H 80-85_17E_19_26 F-AC-
F1-APE, Band 5

4 TEST RESULTS

4.1 EFFECTIVE RADIATED POWER, MEAN OUTPUT POWER AND ZONE ENHANCER GAIN

Standard FCC Part 22, § 22.913

The test was performed according to:

ANSI C63.26, KDB 935210 D05 v01r04: 3.5

Test date: 2020-12-14

Environmental conditions: 22 ° C; 33 % r. F.

Test engineer: Thomas Gerngroß

4.1.1 TEST DESCRIPTION

This test case is intended to demonstrate compliance to the signal booster power and gain limits and requirements for industrial signal boosters per FCC § 22.913, RSS-132 with subpart 5.4 and SRSP-503 with subpart 5.1.1.

The EUT was connected to the test setup according to the following diagram:

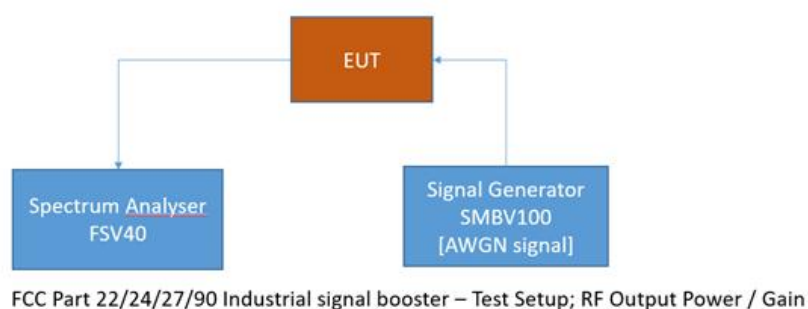

The attenuation of the measuring and stimulus path are known for each measured frequency and are considered.

The Spectrum Analyzer settings can be directly found in the measurement diagrams.



**BUREAU
VERITAS**

ECL-TA-20-020-V01.00

TA tests on Andrew, CAP H 80-85_17E_19_26 F-AC-
F1-APE, Band 5

4.1.2 TEST REQUIREMENTS/LIMITS: ABSTRACTS FROM STANDARDS

Part 22; Public Mobile Services

Subpart H – Cellular Radiotelephone Service

§ 22.913

Abstract § 22.913 from FCC:

(a) *Maximum ERP.* The ERP of transmitters in the Cellular Radiotelephone Service must not exceed the limits in this section.

(1) Except as described in paragraphs (a)(2), (3), and (4) of this section, the ERP of base stations and repeaters must not exceed—

- (i) 500 watts per emission; or
- (ii) 400 watts/MHz (PSD) per sector.

(2) Except as described in paragraphs (a)(3) and (4) of this section, for systems operating in areas more than 72 kilometers (45 miles) from international borders that:

- (i) Are located in counties with population densities of 100 persons or fewer per square mile, based upon the most recently available population statistics from the Bureau of the Census; or
- (ii) Extend coverage into Unserved Area on a secondary basis (see § 22.949), the ERP of base transmitters and repeaters must not exceed—

- (A) 1000 watts per emission; or
- (B) 800 watts/MHz (PSD) per sector.

(3) Provided that they also comply with paragraphs (b) and (c) of this section, licensees are permitted to operate their base transmitters and repeaters with an ERP greater than 400 watts/MHz (PSD) per sector, up to a maximum ERP of 1000 watts/MHz (PSD) per sector unless they meet the conditions in paragraph (a)(4) of this section.

(4) Provided that they also comply with paragraphs (b) and (c) of this section, licensees of systems operating in areas more than 72 kilometers (45 miles) from international borders that:

- (i) Are located in counties with population densities of 100 persons or fewer per square mile, based upon the most recently available population statistics from the Bureau of the Census; or
- (ii) Extend coverage into Unserved Area on a secondary basis (see § 22.949), are permitted to operate base transmitters and repeaters with an ERP greater than 800 watts/MHz (PSD) per sector, up to a maximum of 2000 watts/MHz (PSD) per sector.



ECL-TA-20-020-V01.00

TA tests on Andrew, CAP H 80-85_17E_19_26 F-AC-
F1-APE, Band 5

Abstract RSS-132 from ISED:

RSS-132; 5.4 Transmitter Output Power and Equivalent Isotropically Radiated Power

The transmitter output power shall be measured in terms of average power. The equivalent isotropically radiated power (e.i.r.p.) for mobile equipment shall not exceed 11.5 watts. Refer to SRSP-503 for base station e.i.r.p. limits.

Abstract SRSP-503 from ISED:

SRSP-503; 5.1 Power and Antenna Height Limitations

5.1.1

Base stations for digital systems are limited to 1640 watts maximum equivalent isotropically radiated power (EIRP) with an antenna height above average terrain (HAAT) up to 150 m, except in urban areas³ where they are limited to a maximum allowable EIRP of 820 watts.

5.1.2

Base stations for analogue systems are limited to 820 watts maximum EIRP with an antenna height above average terrain (HAAT) up to 150 m, except in urban areas where they are limited to a maximum allowable EIRP of 164 watts.

5.1.3

The maximum EIRP shall be 11.5 watts for mobile stations.

5.1.4

The EIRP and antenna height shall be limited to that necessary to provide the required service as governed by the system requirements.

5.1.5

A reduction in EIRP from that specified in paragraphs 5.1.1 and 5.1.2 is required for base stations with antenna height above average terrain (HAAT) in excess of 150 m as follows:

$$EIRP_{reduction} = 20 \log_{10} \frac{HAAT}{150}$$

In the above formula, the EIRP reduction is measured in dB and the HAAT is measured in metres.



ECL-TA-20-020-V01.00

TA tests on Andrew, CAP H 80-85_17E_19_26 F-AC-F1-APE, Band 5

4.1.3 TEST PROTOCOL

FCC Table

Band 5, 869 MHz – 894 MHz, downlink							
Signal Type	Input Power	Frequency [MHz]	Input Power [dBm]	Maximum Average Output Power [dBm]	Limit Average Output Power [dBm]	Margin to Limit [dB]	Gain [dB]
Wideband	0.3 dB < AGC	882.84	5.9	42.5	57.0	14.5	36.6
Wideband	3 dB > AGC	882.84	9.2	42.4	57.0	14.6	33.2
Narrowband	0.3 dB < AGC	882.84	5.3	42.4	57.0	14.6	37.1
Narrowband	3 dB > AGC	882.84	8.6	42.6	57.0	14.4	34.0

For the output power limit the lowest value of the FCC table from § 22.913 is taken. This is 500 watts which equates 57.0 dBm according the given formula:

$$p_{dBm} = 10 \log_{10} \frac{500 W}{0.001 W} = 57.0 \text{ dBm}$$

ISED Table

Band 5, 869 MHz – 894 MHz, downlink							
Signal Type	Input Power	Frequency [MHz]	Input Power [dBm]	Maximum Average Output Power [W]	Limit Average Output Power [W]	Margin to Limit [dB]	Gain [dB]
Wideband	0.3 dB < AGC	882.84	5.9	17.3	820	16.8	36.5
Wideband	3 dB > AGC	882.84	9.2	17.5	820	16.7	33.2
Narrowband	0.3 dB < AGC	882.84	5.3	18.0	820	16.6	37.2
Narrowband	3 dB > AGC	882.84	8.6	17.1	820	16.8	33.7

For the output power limit the value for a digital system at a height up to 150 m in urban areas from SRSP-503; 5.1 is taken.

Remark: Please see next sub-clause for the measurement plot.



ECL-TA-20-020-V01.00

TA tests on Andrew, CAP H 80-85_17E_19_26 F-AC-F1-APE, Band 5

4.1.4 MEASUREMENT PLOT

FCC Plots

Downlink: Band 5, 869 MHz - 894 MHz; Frequency: 882.84 MHz; Band Edge: f0; Mod: AWGN; Output Power 0.3 dB < AGC

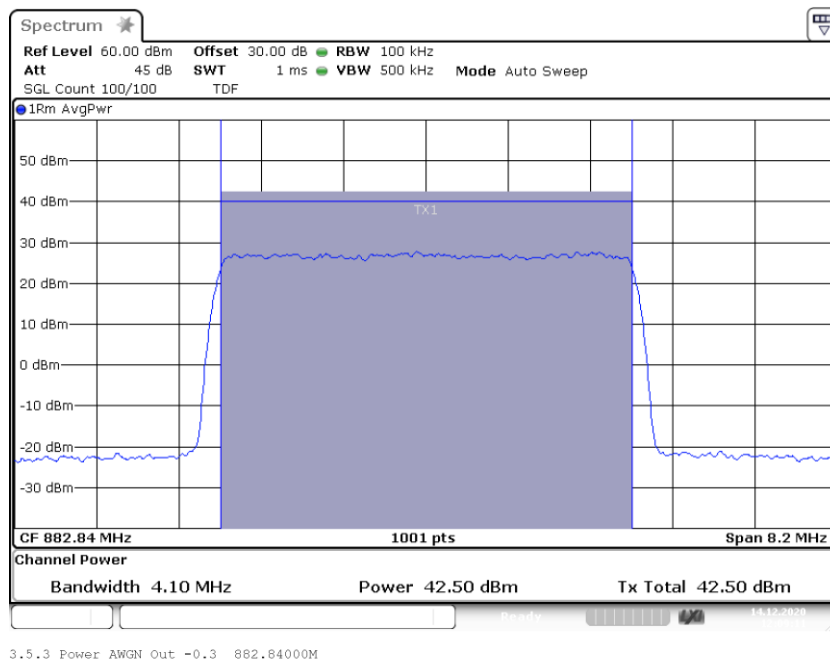

3.5.3 Power AWGN Out -0.3 882.84000M

Downlink: Band 5, 869 MHz - 894 MHz; Frequency: 882.84 MHz; Band Edge: f0; Mod: AWGN; Output Power 3 dB > AGC

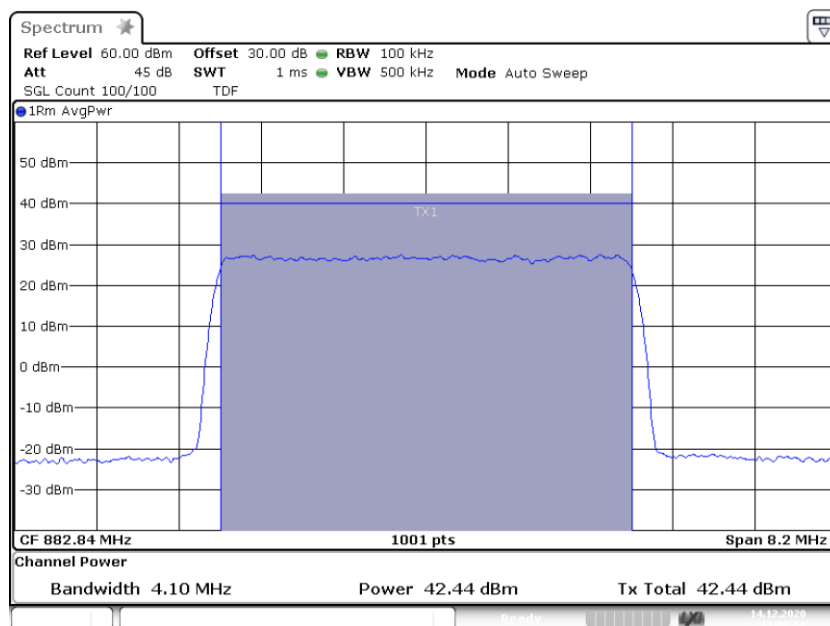

3.5.3 Power AWGN Out +3 882.84000M



BUREAU
VERITAS

ECL-TA-20-020-V01.00

TA tests on Andrew, CAP H 80-85_17E_19_26 F-AC-
F1-APE, Band 5

Downlink: Band 5, 869 MHz - 894 MHz; Frequency: 882.84 MHz; Band Edge: f0; Mod: GSM; Input
Power 0.3 dB < AGC

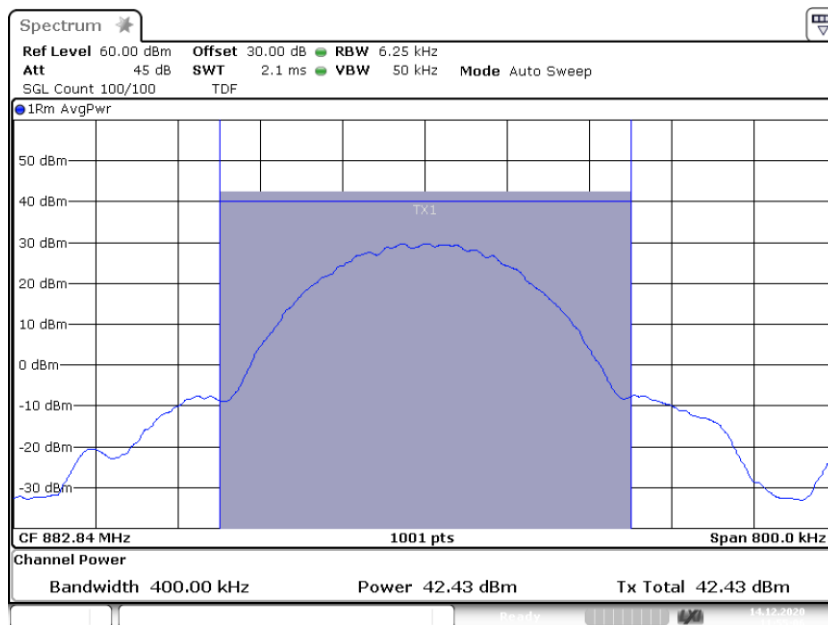

3.5.3 Power GSM Out -0.3 882.84000M

Downlink: Band 5, 869 MHz - 894 MHz; 882.84 MHz; Band Edge: f0; Mod: GSM; Output Power 3 dB
> AGC

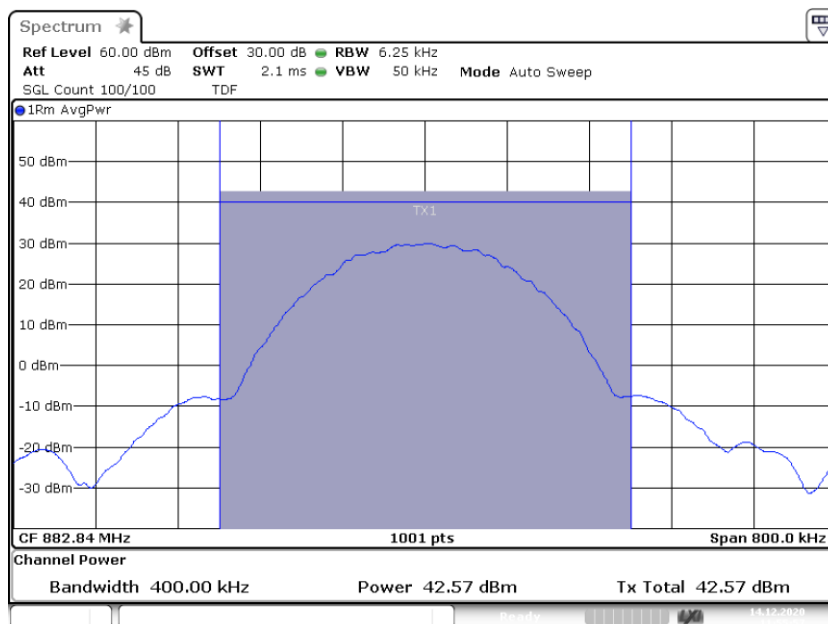

3.5.3 Power GSM Out +3 882.84000M



BUREAU
VERITAS

ECL-TA-20-020-V01.00

TA tests on Andrew, CAP H 80-85_17E_19_26 F-AC-
F1-APE, Band 5

ISED Plots

Downlink: Band 5, 869 MHz - 894 MHz; Frequency: 882.84 MHz; Band Edge: f0; Mod: AWGN;
Output Power 0.3 dB < AGC

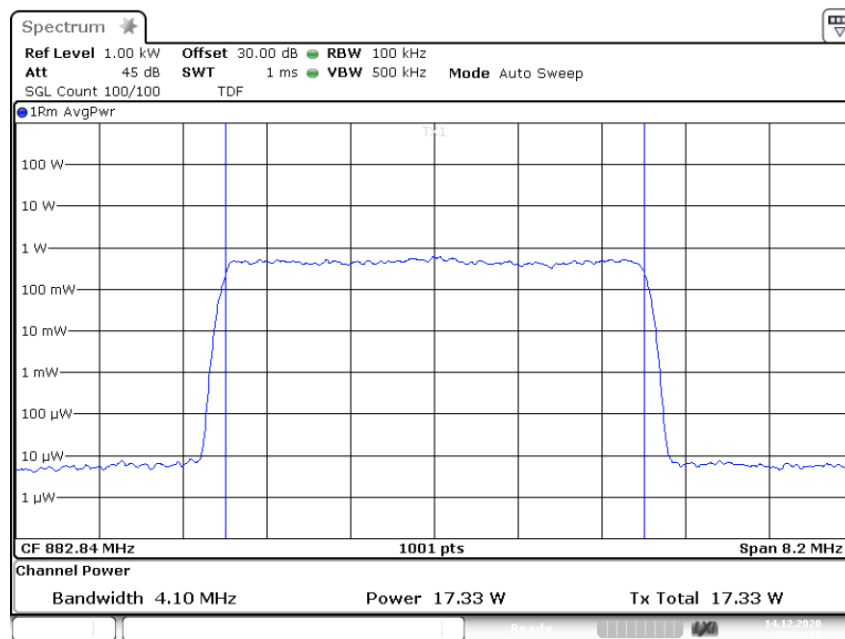

Downlink: Band 5, 869 MHz - 894 MHz; Frequency: 882.84 MHz; Band Edge: f0; Mod: AWGN;
Output Power 3 dB > AGC

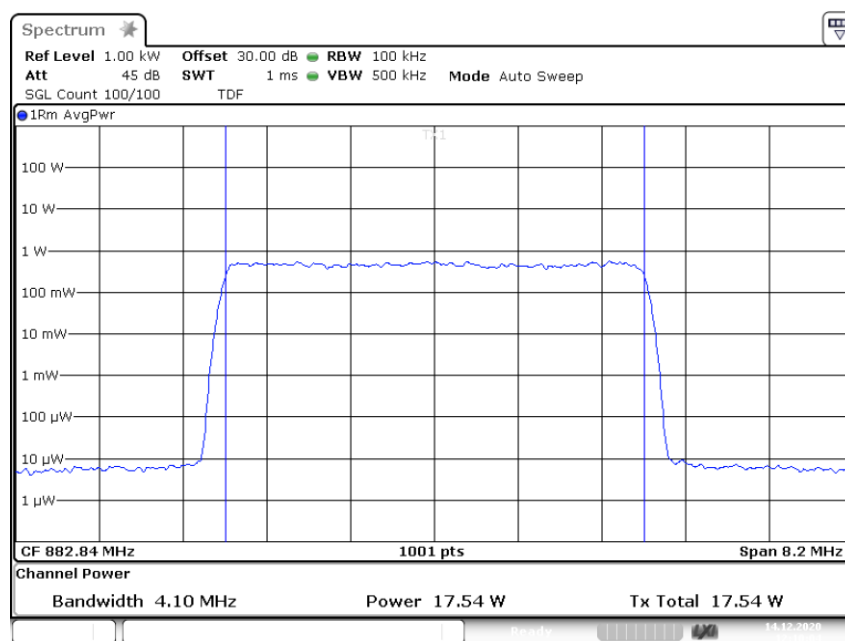



BUREAU
VERITAS

ECL-TA-20-020-V01.00

TA tests on Andrew, CAP H 80-85_17E_19_26 F-AC-
F1-APE, Band 5

Downlink: Band 5, 869 MHz - 894 MHz; Frequency: 882.84 MHz; Band Edge: f0; Mod: GSM; Input
Power 0.3 dB < AGC

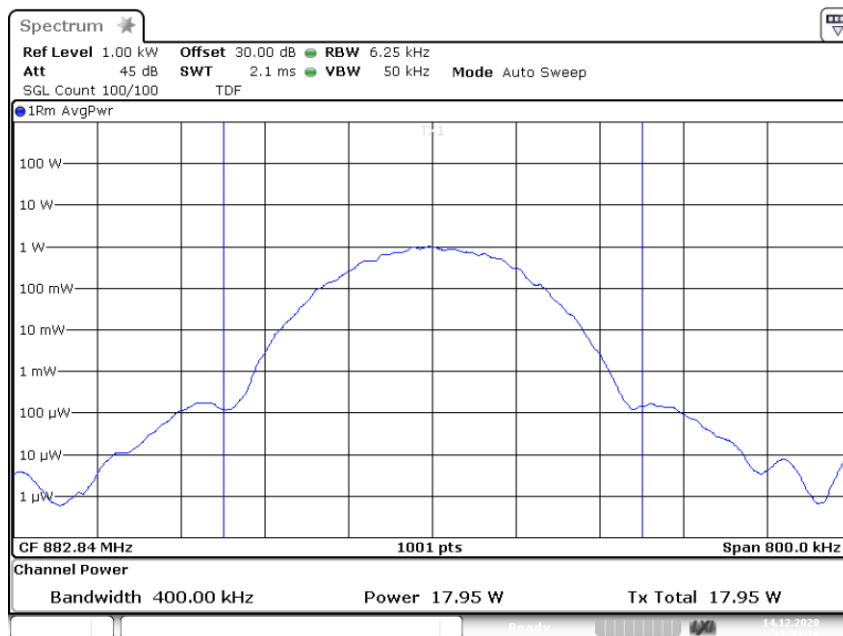

3.5.3 Power_W GSM Out -0.3 882.84000M

Downlink: Band 5, 869 MHz - 894 MHz; 882.84 MHz; Band Edge: f0; Mod: GSM; Output Power 3 dB
> AGC

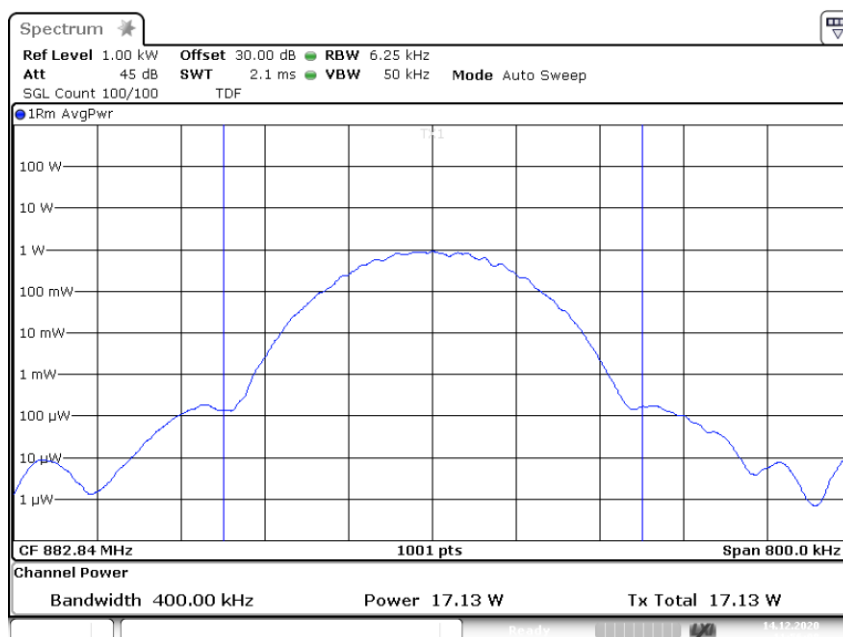

3.5.3 Power_W GSM Out +3 882.84000M



ECL-TA-20-020-V01.00

TA tests on Andrew, CAP H 80-85_17E_19_26 F-AC-F1-APE, Band 5

4.1.5 TEST EQUIPMENT USED

- Conducted



ECL-TA-20-020-V01.00

TA tests on Andrew, CAP H 80-85_17E_19_26 F-AC-
F1-APE, Band 5

4.2 PEAK TO AVERAGE RATIO

Standard FCC Part 22, § 22.913

The test was performed according to:
ANSI C63.26

Test date: 2020-12-14

Environmental conditions: 22 ° C; 33 % r. F.

Test engineer: Thomas Gerngroß

4.2.1 TEST DESCRIPTION

This test case is intended to measure the peak to average ratio.

This test case is intended to demonstrate compliance of the peak to average ratio of the signal booster per FCC § 22.913 and RSS-132 with subpart 5.4.

The EUT was connected to the test setup according to the following diagram:

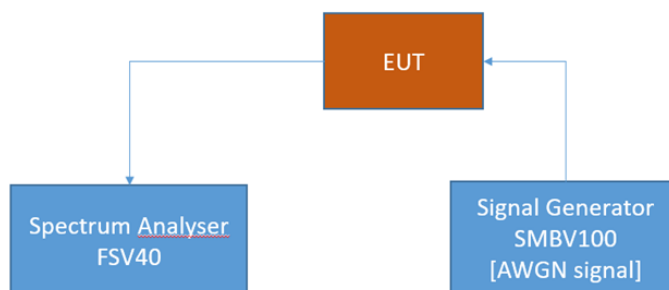

FCC Part 22/24/27/90 Industrial signal booster – Test Setup; RF Output Power / Gain

The attenuation of the measuring and stimulus path are known for each measured frequency and are considered.

The Spectrum Analyzer settings can be directly found in the measurement diagrams.



ECL-TA-20-020-V01.00

TA tests on Andrew, CAP H 80-85_17E_19_26 F-AC-F1-APE, Band 5

4.2.2 TEST REQUIREMENTS/LIMITS

Part 22; Public Mobile Services

Subpart H – Cellular Radiotelephone Service

§ 22.913

Abstract § 22.913 from FCC:

(d) Power measurement. Measurement of the ERP of Cellular base transmitters and repeaters must be made using an average power measurement technique. The peak-to-average ratio (PAR) of the transmission must not exceed 13 dB.

Abstract RSS-132 from ISED:

RSS-132; 5.4 Transmitter Output Power and Equivalent Isotropically Radiated Power

In addition, the peak-to-average power ratio (PAPR) of the transmitter shall not exceed 13 dB for more than 0.1% of the time using a signal corresponding to the highest PAPR during periods of continuous transmission.

4.2.3 TEST PROTOCOL

Band 5, 869 MHz - 894 MHz, downlink						
Signal Type	Input Power	Frequency [MHz]	Input Power [dBm]	PAPR [dB]	Limit PAPR [dB]	Margin to Limit [dB]
Wideband	0.3 dB < AGC	881.50	5.7	8.35	13.00	4.65
Wideband	3 dB > AGC	881.50	9.0	8.35	13.00	4.65
Narrowband	0.3 dB < AGC	881.50	5.3	0.20	13.00	12.80
Narrowband	3 dB > AGC	881.50	8.6	0.20	13.00	12.80

Remark: Please see next sub-clause for the measurement plot.



ECL-TA-20-020-V01.00

TA tests on Andrew, CAP H 80-85_17E_19_26 F-AC-F1-APE, Band 5

4.2.4 MEASUREMENT PLOT (SHOWING THE HIGHEST VALUE, "WORST CASE")

Downlink: Band 5, 869 MHz - 894 MHz; Frequency: 881.50 MHz; Band Edge: f0; Mod: AWGN; PAPR 0.3 dB < AGC

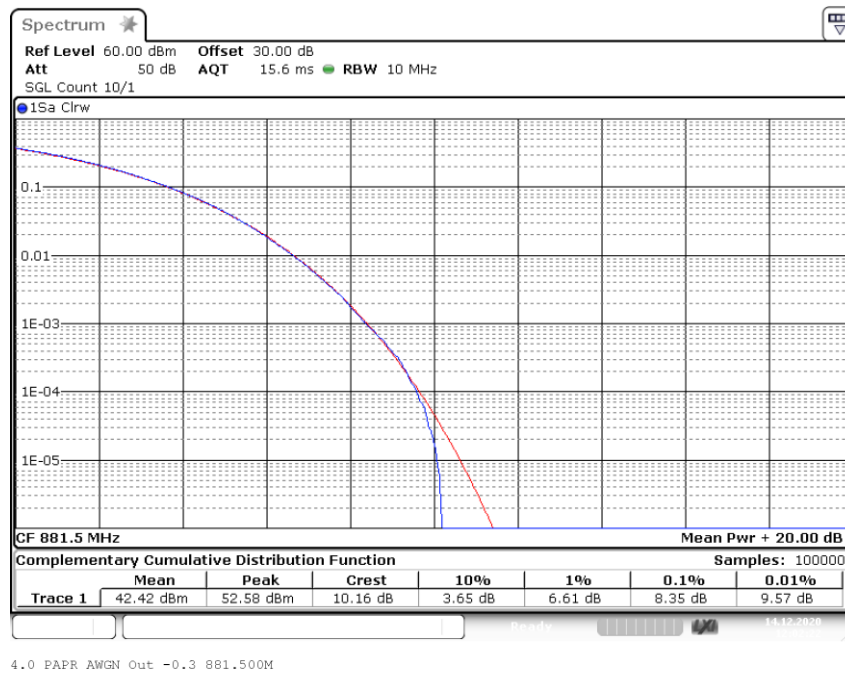

Downlink: Band 5, 869 MHz - 894 MHz; Frequency: 881.500 MHz; Band Edge: f0; Mod: AWGN; PAPR 3 dB > AGC

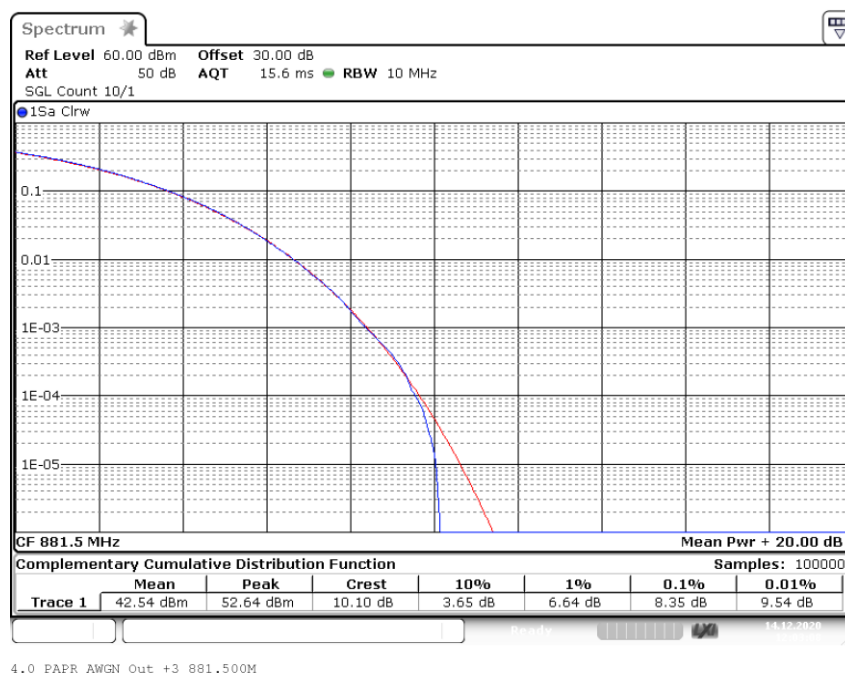



BUREAU VERITAS

ECL-TA-20-020-V01.00

TA tests on Andrew, CAP H 80-85_17E_19_26 F-AC-F1-APE, Band 5

Downlink: Band 5, 869 MHz - 894 MHz; Frequency: 881.50 MHz; Band Edge: mid; Mod: GSM; PAPR 0.3 dB < AGC

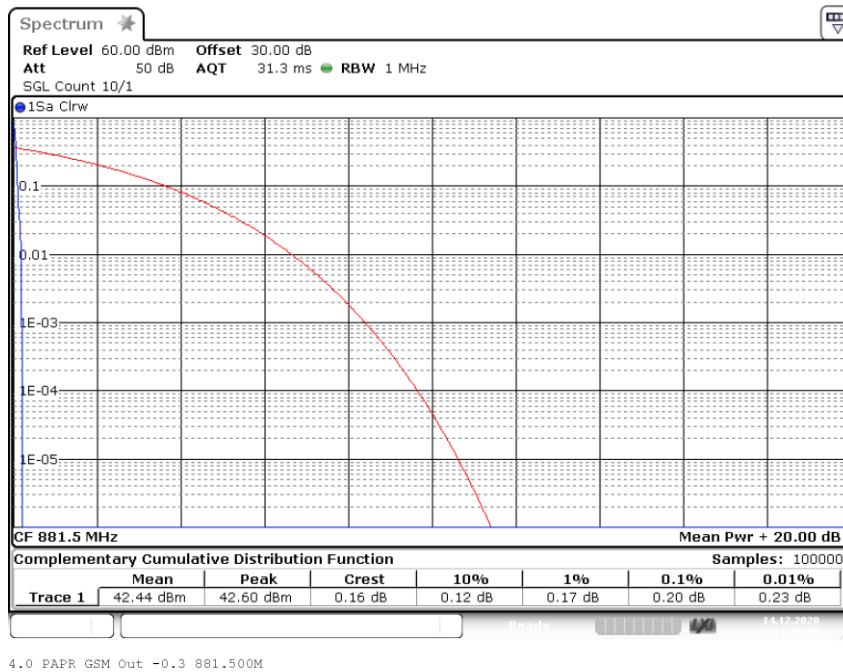

Downlink: Band 5, 869 MHz - 894 MHz; Frequency: 881.50 MHz; Band Edge: mid; Mod: GSM; PAPR 3 dB > AGC

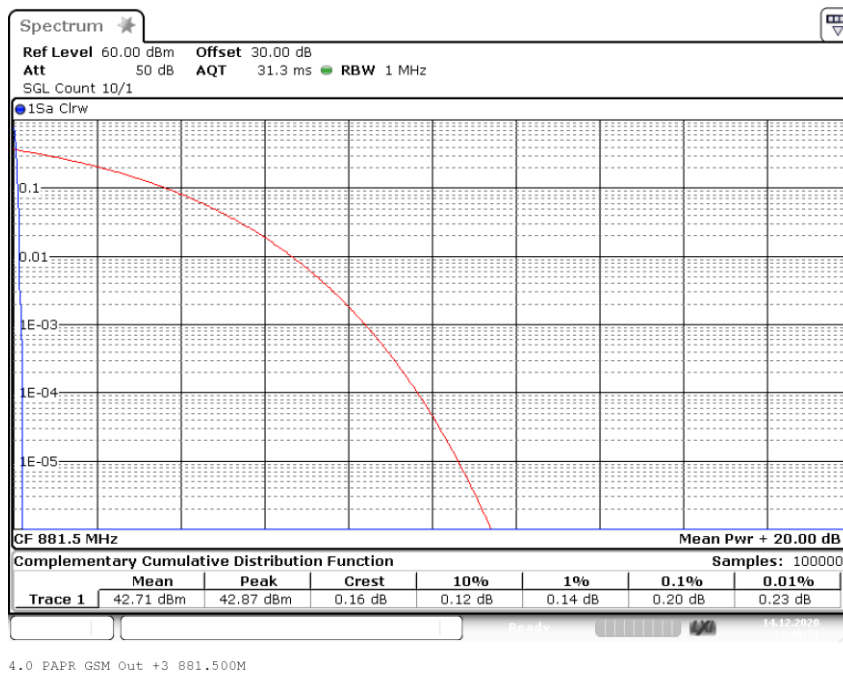

4.2.5 TEST EQUIPMENT USED

- Conducted



ECL-TA-20-020-V01.00

TA tests on Andrew, CAP H 80-85_17E_19_26 F-AC-F1-APE, Band 5

4.3 OCCUPIED BANDWIDTH/INPUT-VERSUS-OUTPUT SPECTRUM

Standard FCC Part 2.1049

The test was performed according to: ANSI C63.26, KDB 935210 D05 v01r04: 3.4

Test date: 2020-12-14

Environmental conditions: 22 ° C; 33 % r. F.

Test engineer: Thomas Gerngroß

4.3.1 TEST DESCRIPTION

This test case is intended to demonstrate compliance to the applicable conducted spurious emission limits per FCC § 2.1049, RSS-GEN with subpart 6.7 and RSS-131 with subpart 5.2.2.

The EUT was connected to the test setups according to the following diagram:

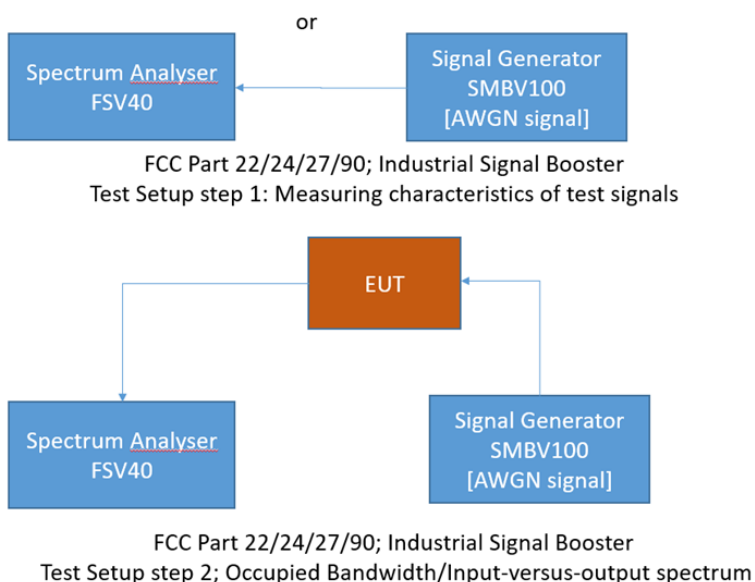

The attenuation of the measuring and stimulus path are known for each measured frequency and are considered.

The Spectrum Analyzer settings can be directly found in the measurement diagrams.



ECL-TA-20-020-V01.00

TA tests on Andrew, CAP H 80-85_17E_19_26 F-AC-
F1-APE, Band 5

4.3.2 TEST REQUIREMENTS/LIMITS

Abstract § 2.1049 from FCC:

FCC Part 2.1049; Occupied Bandwidth:

The occupied bandwidth, that is the frequency bandwidth such that, below its lower and above its upper frequency limits, the mean powers radiated are each equal to 0.3 percent of the total mean power radiated by a given emission shall be measured under the following conditions as applicable:

(h) Transmitters employing digital modulation techniques—when modulated by an input signal such that its amplitude and symbol rate represent the maximum rated conditions under which the equipment will be operated. The signal shall be applied through any filter networks, pseudo-random generators or other devices required in normal service. Additionally, the occupied bandwidth shall be shown for operation with any devices used for modifying the spectrum when such devices are optional at the discretion of the user.

(i) Transmitters designed for other types of modulation—when modulated by an appropriate signal of sufficient amplitude to be representative of the type of service in which used. A description of the input signal should be supplied.

Abstract RSS-GEN from ISED:

RSS-GEN; 6.7 Occupied Bandwidth

The occupied bandwidth or the “99% emission bandwidth” is defined as the frequency range between two points, one above and the other below the carrier frequency, within which 99% of the total transmitted power of the fundamental transmitted emission is contained. The occupied bandwidth shall be reported for all equipment in addition to the specified bandwidth required in the applicable RSSs.

In some cases, the “x dB bandwidth” is required, which is defined as the frequency range between two points, one at the lowest frequency below and one at the highest frequency above the carrier frequency, at which the maximum power level of the transmitted emission is attenuated x dB below the maximum in-band power level of the modulated signal, where the two points are on the outskirts of the in-band emission.

The following conditions shall be observed for measuring the occupied bandwidth and x dB bandwidth:

- The transmitter shall be operated at its maximum carrier power measured under normal test conditions.
- The span of the spectrum analyzer shall be set large enough to capture all products of the modulation process, including the emission skirts, around the carrier frequency, but small enough to avoid having other emissions (e.g. on adjacent channels) within the span.



ECL-TA-20-020-V01.00

TA tests on Andrew, CAP H 80-85_17E_19_26 F-AC-F1-APE, Band 5

- The detector of the spectrum analyzer shall be set to "Sample". However, a peak, or peak hold, may be used in place of the sampling detector since this usually produces a wider bandwidth than the actual bandwidth (worst-case measurement). Use of a peak hold (or "Max Hold") may be necessary to determine the occupied / x dB bandwidth if the device is not transmitting continuously.
- The resolution bandwidth (RBW) shall be in the range of 1% to 5% of the actual occupied / x dB bandwidth and the video bandwidth (VBW) shall not be smaller than three times the RBW value. Video averaging is not permitted.

For the 99% emission bandwidth, the trace data points are recovered and directly summed in linear power level terms. The recovered amplitude data points, beginning at the lowest frequency, are placed in a running sum until 0.5% of the total is reached, and that frequency recorded. The process is repeated for the highest frequency data points (starting at the highest frequency, at the right side of the span, and going down in frequency). This frequency is then recorded. The difference between the two recorded frequencies is the occupied bandwidth (or the 99% emission bandwidth).

Abstract RSS-131 from ISED:

RSS-131; 5.2.2 Input-versus-output spectrum

The spectral growth of the 26 dB bandwidth of the output signal shall be less than 5% of the input signal spectrum.

4.3.3 TEST PROTOCOL

Band 5, 869 MHz - 894 MHz, downlink							
Signal Type	Input Power	Signal Frequency [MHz]	Occupied Bandwidth SG [kHz]	Occupied Bandwidth Booster [kHz]	Delta Occupied Bandwidth [kHz]	Limit Delta Occupied Bandwidth [kHz]	Margin to Limit [kHz]
Wideband	0.3 dB < AGC	881.50	4389.4	4388.2	1.2	205.0	203.8
Wideband	3 dB > AGC	881.50	4390.7	4388.2	2.5	205.0	202.5
Narrowband	0.3 dB < AGC	881.50	320.1	320.0	0.1	10.0	9.9
Narrowband	3 dB > AGC	881.50	318.8	317.0	1.8	10.0	8.2

Remark: Please see next sub-clause for the measurement plot.



ECL-TA-20-020-V01.00

TA tests on Andrew, CAP H 80-85_17E_19_26 F-AC-F1-APE, Band 5

4.3.4 MEASUREMENT PLOT

Downlink: Band 5, 869 MHz - 894 MHz; Frequency: 881.50 MHz; Band Edge: mid; Mod: AWGN; Input OCBw 0.3 dB < AGC

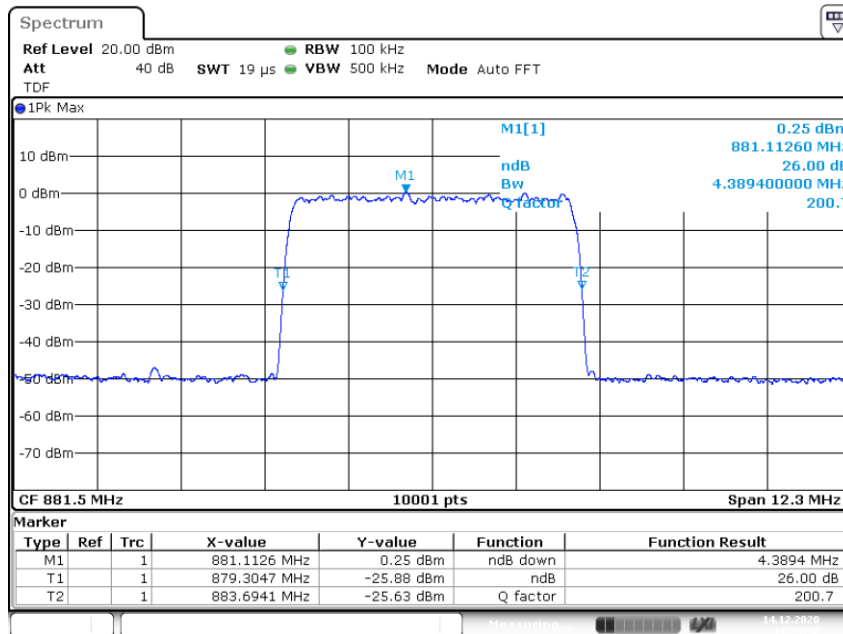

3.4 OCBw AWGN In -0.3 881.5000M _26dB

Input Signal

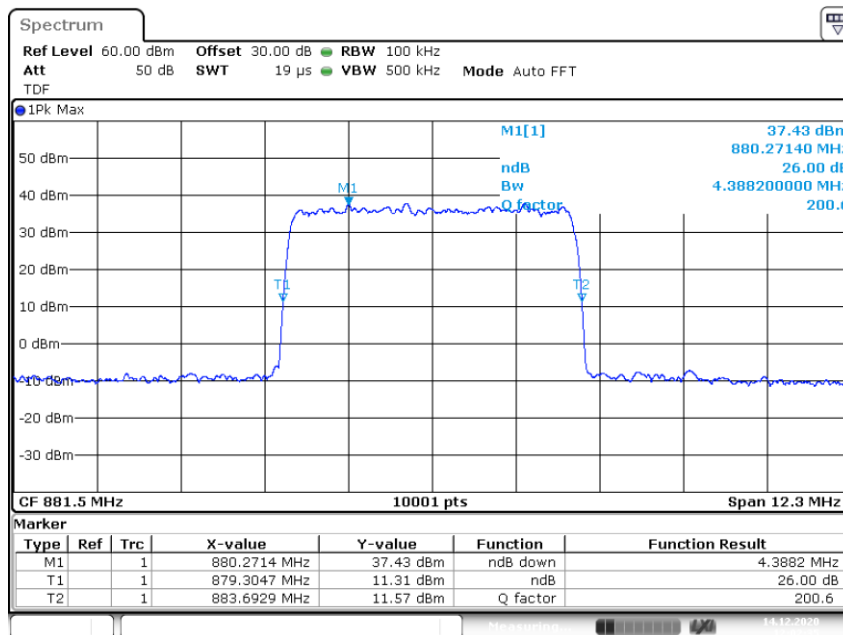

3.4 OCBw AWGN Out -0.3 881.5000M _26dB

Output Signal



**BUREAU
VERITAS**

ECL-TA-20-020-V01.00

TA tests on Andrew, CAP H 80-85_17E_19_26 F-AC-
F1-APE, Band 5

Downlink: Band 5, 869 MHz - 894 MHz; Frequency: 881.50 MHz; Band Edge: mid; Mod: AWGN;
Input OCBw 3 dB > AGC

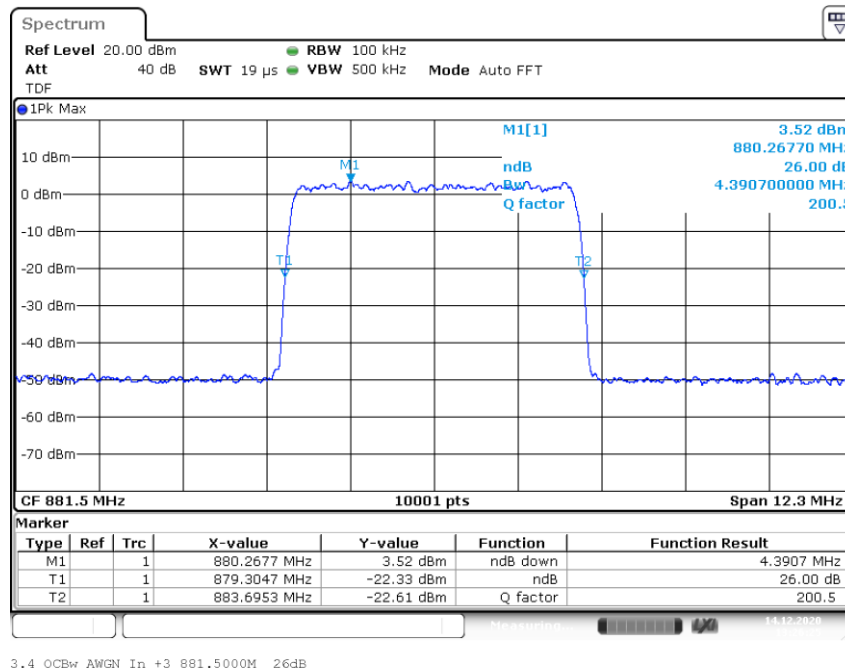

Input Signal

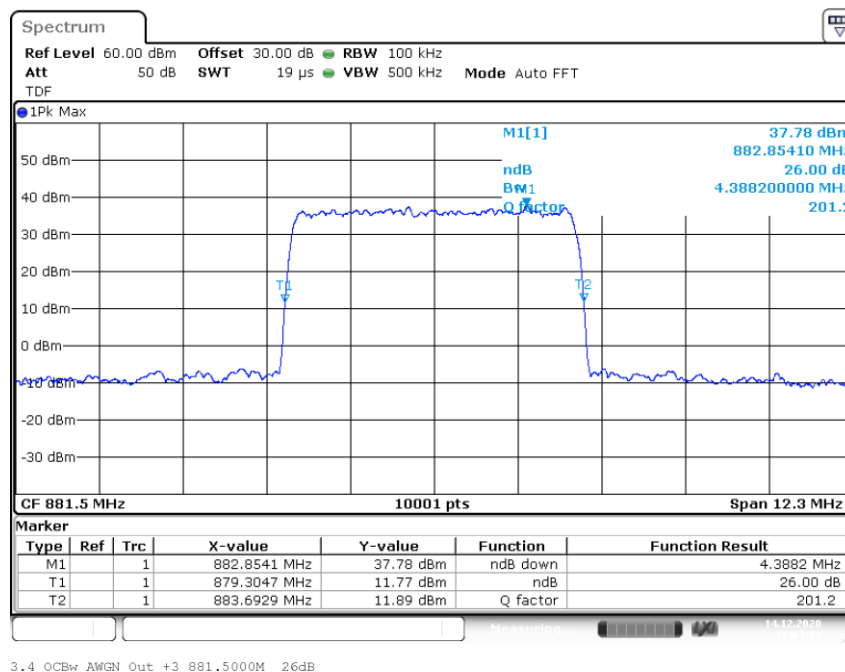

Output Signal



BUREAU VERITAS

ECL-TA-20-020-V01.00

TA tests on Andrew, CAP H 80-85_17E_19_26 F-AC-F1-APE, Band 5

Downlink: Band 5, 869 MHz - 894 MHz; Frequency: 881.50 MHz; Band Edge: mid; Mod: GSM; Input OCBw 0.3 dB < AGC

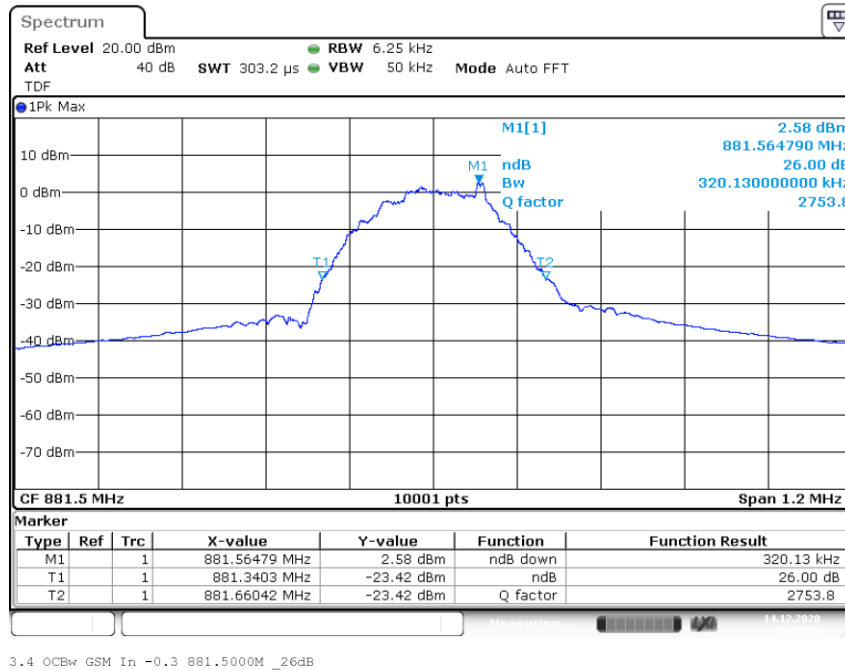

Input Signal

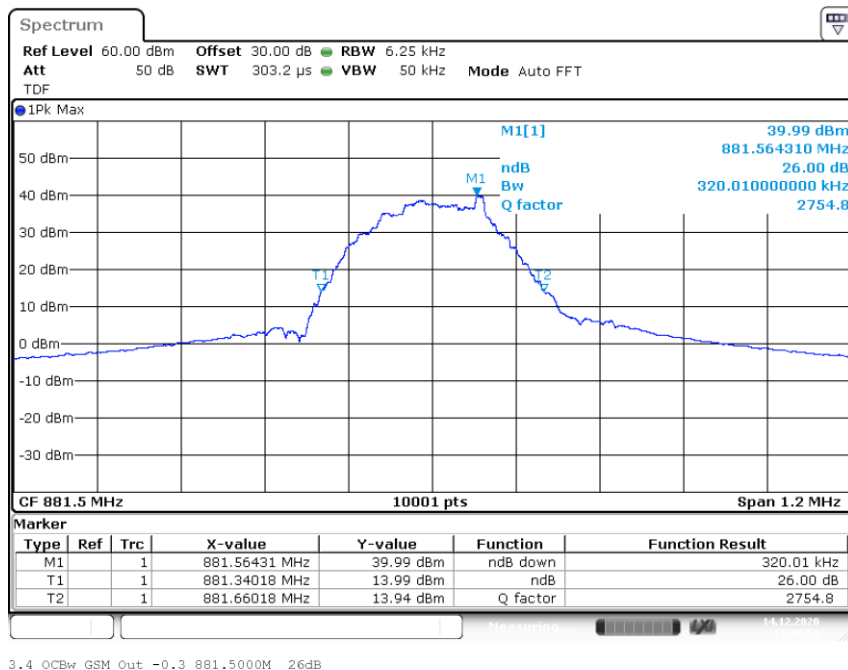

Output Signal



**BUREAU
VERITAS**

ECL-TA-20-020-V01.00

TA tests on Andrew, CAP H 80-85_17E_19_26 F-AC-
F1-APE, Band 5

Downlink: Band 5, 869 MHz - 894 MHz; Frequency: 881.50 MHz; Band Edge: mid; Mod: GSM; Input
OCBw 3 dB > AGC

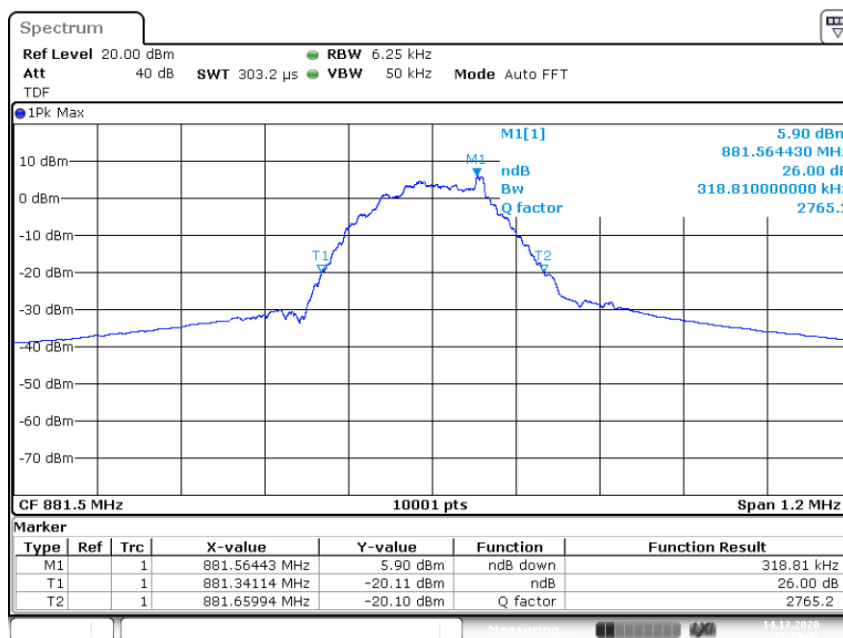

3.4 OCBw GSM In +3 881.5000M _26dB

7

Input Signal

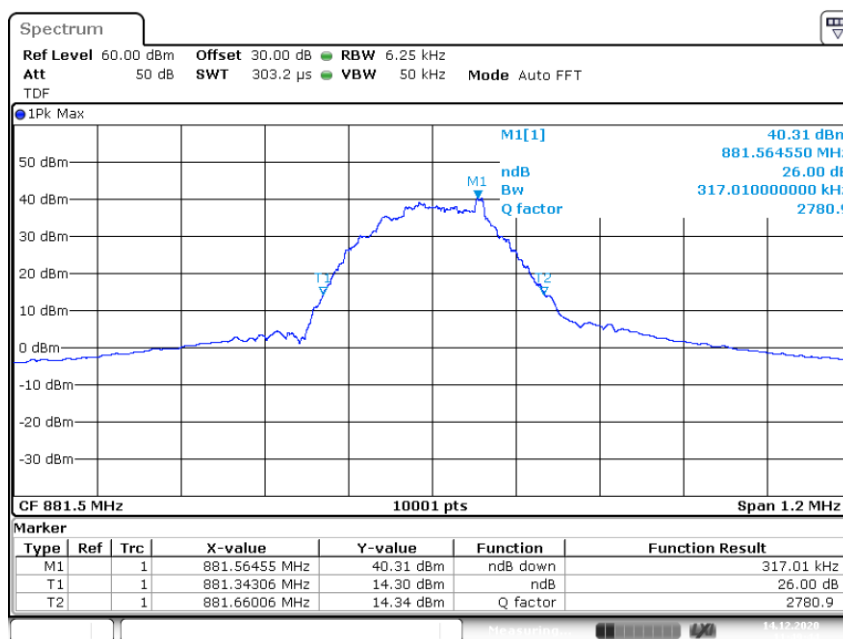

3.4 OCBw GSM Out +3 881.5000M _26dB

Output Signal

4.3.5 TEST EQUIPMENT USED

- Conducted



ECL-TA-20-020-V01.00

TA tests on Andrew, CAP H 80-85_17E_19_26 F-AC-
F1-APE, Band 5

4.4 CONDUCTED SPURIOUS EMISSIONS AT ANTENNA TERMINALS

Standard FCC Part § 2.1051, § 22.917

The test was performed according to:
ANSI C63.26, KDB 935210 D05 v01r04: 3.6

Test date: 2020-12-16

Environmental conditions: 23 ° C; 34 % r. F.

Test engineer: Thomas Gerngroß

4.4.1 TEST DESCRIPTION

This test case is intended to demonstrate compliance to the signal booster power and gain limits and requirements for industrial signal boosters per FCC § 2.1051, FCC § 22.917 and RSS-132 with subpart 5.5.

The EUT was connected to the test setup according to the following diagram:

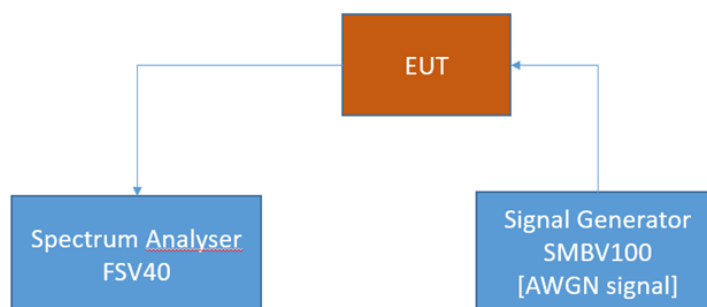

FCC Part 22/24/27/90 Industrial signal booster – Test Setup; RF Output Power / Gain

The attenuation of the measuring and stimulus path are known for each measured frequency and are considered.

The Spectrum Analyzer settings can be directly found in the measurement diagrams.



ECL-TA-20-020-V01.00

TA tests on Andrew, CAP H 80-85_17E_19_26 F-AC-
F1-APE, Band 5

4.4.2 TEST REQUIREMENTS/LIMITS

Abstract § 2.1051 from FCC:

FCC Part 2.1051; Measurement required: Spurious emissions at antenna terminal:

The radio frequency voltage or powers generated within the equipment and appearing on a spurious frequency shall be checked at the equipment output terminals when properly loaded with a suitable artificial antenna. Curves or equivalent data shall show the magnitude of each harmonic and other spurious emission that can be detected when the equipment is operated under the conditions specified in § 2.1049 as appropriate. The magnitude of spurious emissions which are attenuated more than 20 dB below the permissible value need not be specified.

Abstract § 90.691 FCC:

§ 90.691 Emission mask requirements for EA-based systems.

(a) Out-of-band emission requirement shall apply only to the "outer" channels included in an EA license and to spectrum adjacent to interior channels used by incumbent licensees. The emission limits are as follows:

(2) For any frequency removed from the EA licensee's frequency block greater than 37.5 kHz, the power of any emission shall be attenuated below the transmitter power (P) in watts by at least $43 + 10\log_{10}(P)$ decibels or 80 decibels, whichever is the lesser attenuation, where f is the frequency removed from the center of the outer channel in the block in kilohertz and where f is greater than 37.5 kHz.

Abstract RSS-119 5.8.9.2 from ISED:

5.8.9.2 Out-of-Band Emission Limit

On any frequency outside of the ranges specified in the ACP tables 13 to 16, the power of any emission shall be attenuated below the mean output power P (dBW) by at least $43 + 10\log_{10}(p)$, measured in a 100 kHz bandwidth for frequencies less than or equal to 1 GHz, and in a 1 MHz bandwidth for frequencies greater than 1 GHz..



ECL-TA-20-020-V01.00

TA tests on Andrew, CAP H 80-85_17E_19_26 F-AC-

F1-APE, Band 5

4.4.3 TEST PROTOCOL

Band 5, 869 MHz - 894 MHz, downlink							
Test Frequency	Signal Type	Spurious Freq. [MHz]	Spurious Level [dBm]	Detector	RBW [kHz]	Limit [dBm]	Margin to Limit [dB]
low	Wideband	0.011355	-48.8	RMS	1	-33.0	15.8
low	Wideband	0.152483	-41.0	RMS	10	-23.0	18.0
low	Wideband	117.9	-35.2	RMS	100	-13.0	22.2
low	Wideband	711.4	-34.7	RMS	100	-13.0	21.7
low	Wideband	868.8	-38.2	RMS	10	-23.0	15.2
low	Wideband	894.2	-45.0	RMS	10	-23.0	22.0
low	Wideband	952.6	-33.4	RMS	100	-13.0	20.4
low	Wideband	2141.2	-17.2	RMS	1000	-13.0	4.2
mid	Wideband	0.012461	-48.5	RMS	1	-33.0	15.5
mid	Wideband	0.152483	-41.2	RMS	10	-23.0	18.2
mid	Wideband	122.6	-34.9	RMS	100	-13.0	21.9
mid	Wideband	812.4	-33.9	RMS	100	-13.0	20.9
mid	Wideband	868.8	-45.1	RMS	10	-23.0	22.1
mid	Wideband	894.2	-44.6	RMS	10	-23.0	21.6
mid	Wideband	954.7	-32.5	RMS	100	-13.0	19.5
mid	Wideband	2145.2	-18.0	RMS	1000	-13.0	5.0
high	Wideband	0.016065	-48.8	RMS	1	-33.0	15.8
high	Wideband	0.087494	-41.6	RMS	10	-23.0	18.6
high	Wideband	119.7	-35.6	RMS	100	-13.0	22.6
high	Wideband	709.6	-34.4	RMS	100	-13.0	21.4
high	Wideband	868.9	-45.3	RMS	10	-23.0	22.3
high	Wideband	894.2	-33.1	RMS	10	-23.0	10.1
high	Wideband	937.2	-33.9	RMS	100	-13.0	20.9
high	Wideband	2147.2	-18.0	RMS	1000	-13.0	5.0



ECL-TA-20-020-V01.00

TA tests on Andrew, CAP H 80-85_17E_19_26 F-AC-

F1-APE, Band 5

Band 5, 869 MHz - 894 MHz, downlink							
Test Frequency	Signal Type	Spurious Freq. [MHz]	Spurious Level [dBm]	Detector	RBW [kHz]	Limit [dBm]	Margin to Limit [dB]
low	Narrowband	0.009389	-49.9	RMS	1	-33.0	16.9
low	Narrowband	0.092493	-45.0	RMS	10	-23.0	22.0
low	Narrowband	65.6	-35.3	RMS	100	-13.0	22.3
low	Narrowband	709.9	-34.6	RMS	100	-13.0	21.6
low	Narrowband	868.9	-39.0	RMS	10	-23.0	16.0
low	Narrowband	894.2	-43.4	RMS	10	-23.0	20.4
low	Narrowband	953.3	-33.7	RMS	100	-13.0	20.7
low	Narrowband	2145.2	-17.2	RMS	1000	-13.0	4.2
mid	Narrowband	0.013977	-51.0	RMS	1	-33.0	18.0
mid	Narrowband	0.057499	-45.4	RMS	10	-23.0	22.4
mid	Narrowband	76.4	-35.6	RMS	100	-13.0	22.6
mid	Narrowband	814.5	-34.7	RMS	100	-13.0	21.7
mid	Narrowband	868.7	-45.3	RMS	10	-23.0	22.3
mid	Narrowband	894.2	-44.8	RMS	10	-23.0	21.8
mid	Narrowband	940.2	-33.5	RMS	100	-13.0	20.5
mid	Narrowband	1962.7	-17.9	RMS	1000	-13.0	4.9
high	Narrowband	0.010741	-51.8	RMS	1	-33.0	18.8
high	Narrowband	0.092493	-44.8	RMS	10	-23.0	21.8
high	Narrowband	122.8	-35.2	RMS	100	-13.0	22.2
high	Narrowband	820.8	-31.8	RMS	100	-13.0	18.8
high	Narrowband	868.9	-45.5	RMS	10	-23.0	22.5
high	Narrowband	894.1	-38.4	RMS	10	-23.0	15.4
high	Narrowband	939.3	-33.6	RMS	100	-13.0	20.6
high	Narrowband	2142.2	-18.0	RMS	1000	-13.0	5.0

Remark: Please see next sub-clause for the measurement plot.

General considerations concerning the measurement plots:

The measuring bandwidth of 100 kHz was chosen according the test requirements except at the band edges: At the band edges reducing of measurement bandwidth was necessary to prevent overlaying the RF-signal over the spurious emissions.

Also outside the downlink frequency band at lower frequencies the measurement bandwidths were reduced to have the possibility to record the spurious emissions at these lower frequencies.

At frequencies where measuring bandwidths were reduced also the border lines were reduced according the given formula:

$$p_{RBWreduced} [dBm] = 10 * \log \left(\frac{RBWreduced [kHz] - 100 kHz}{100 kHz} \right) + p_{RBW 100 kHz} [dBm]$$

Hereby "p" are the border lines' values.



ECL-TA-20-020-V01.00

TA tests on Andrew, CAP H 80-85_17E_19_26 F-AC-F1-APE, Band 5

4.4.4 MEASUREMENT PLOT (SHOWING THE HIGHEST VALUE, "WORST CASE")

Frequency Band = Band SMR, 869 MHz - 894 MHz, Test Frequency = low, Direction = RF downlink, Signal Type = AWGN

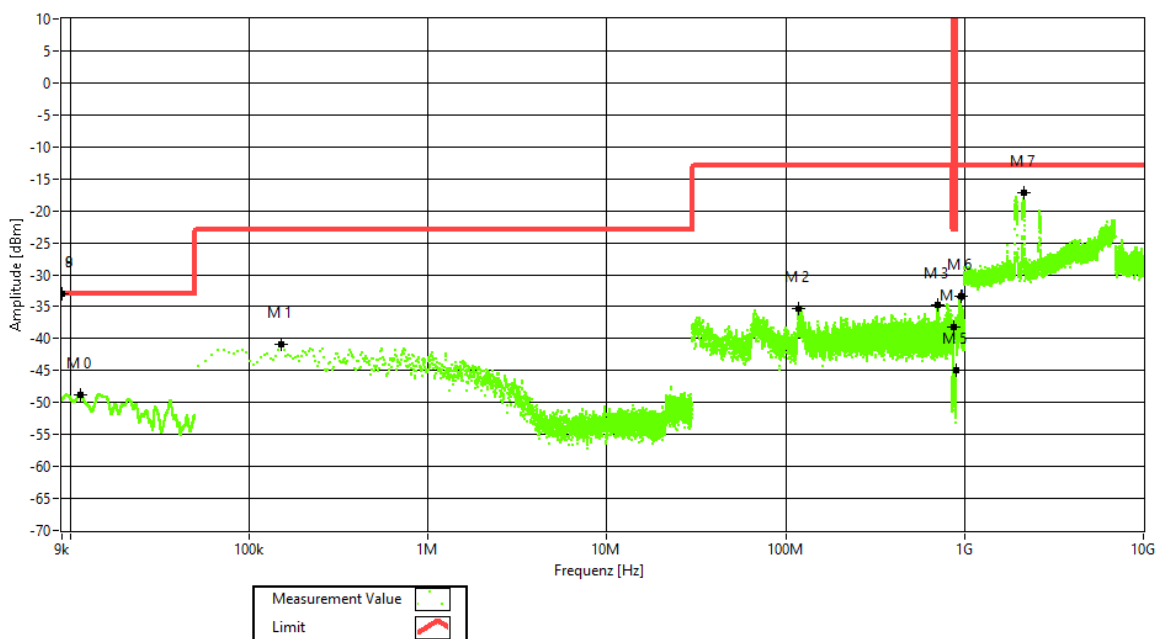

Frequency Band = Band SMR, 862 MHz - 869 MHz, Test Frequency = mid, Direction = RF downlink, Signal Type = AWGN

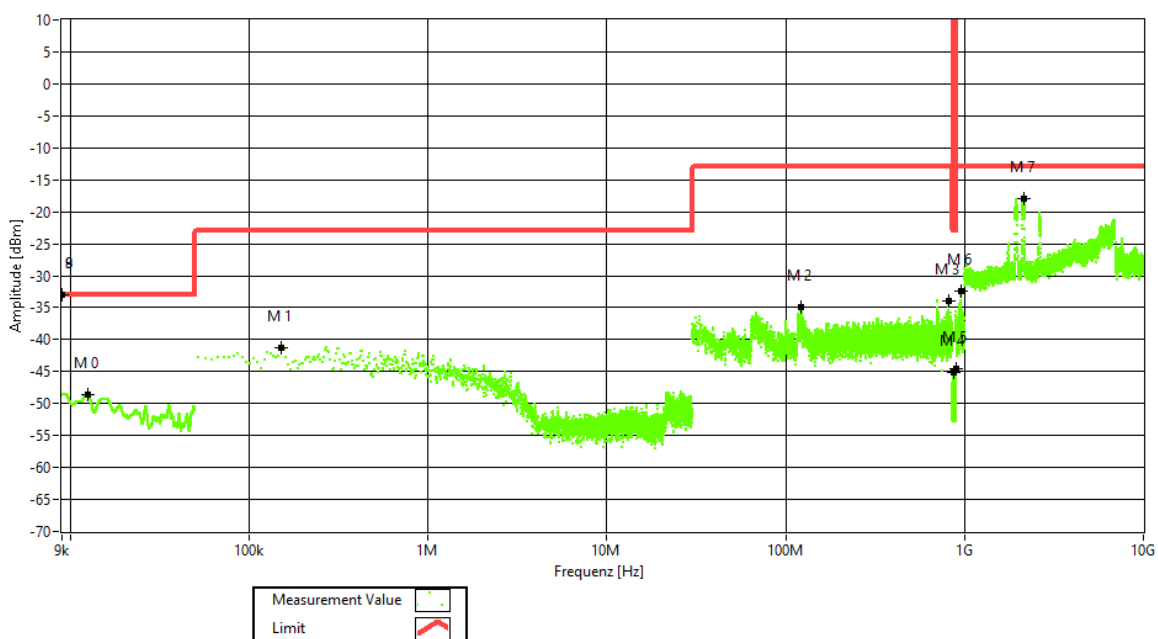



BUREAU
VERITAS

ECL-TA-20-020-V01.00

TA tests on Andrew, CAP H 80-85_17E_19_26 F-AC-
F1-APE, Band 5

Frequency Band = Band 5, 869 MHz - 894 MHz, Test Frequency = high, Direction = RF
downlink, Signal Type = AWGN

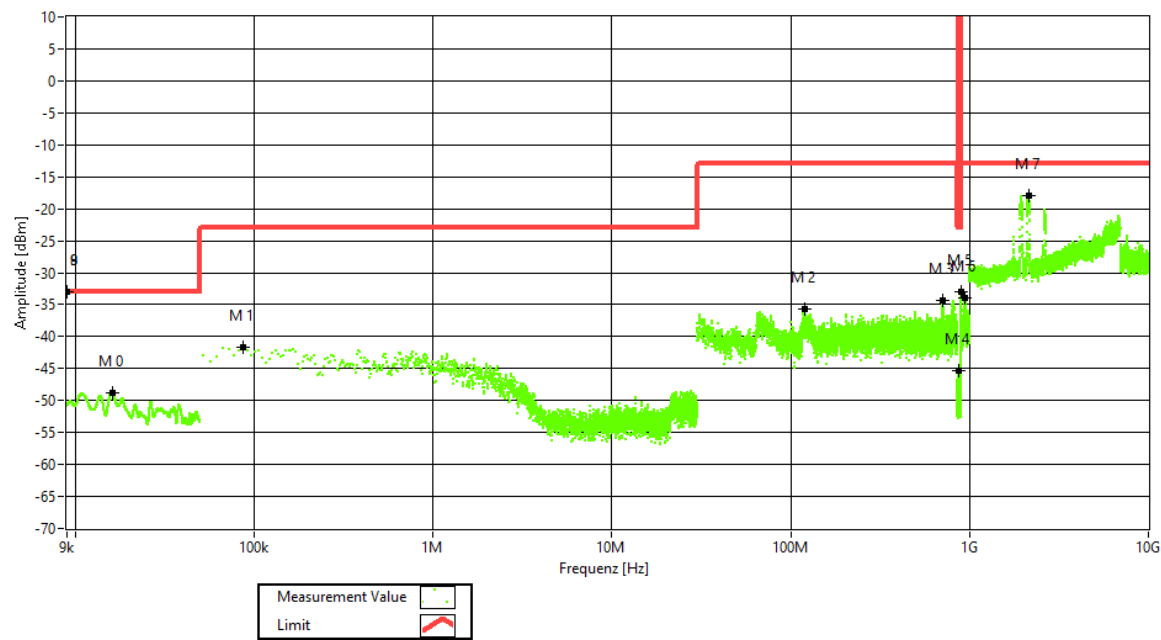



BUREAU
VERITAS

ECL-TA-20-020-V01.00

TA tests on Andrew, CAP H 80-85_17E_19_26 F-AC-
F1-APE, Band 5

Frequency Band = Band 5, 869 MHz - 894 MHz, Test Frequency = low, Direction = RF
downlink, Signal Type = GSM

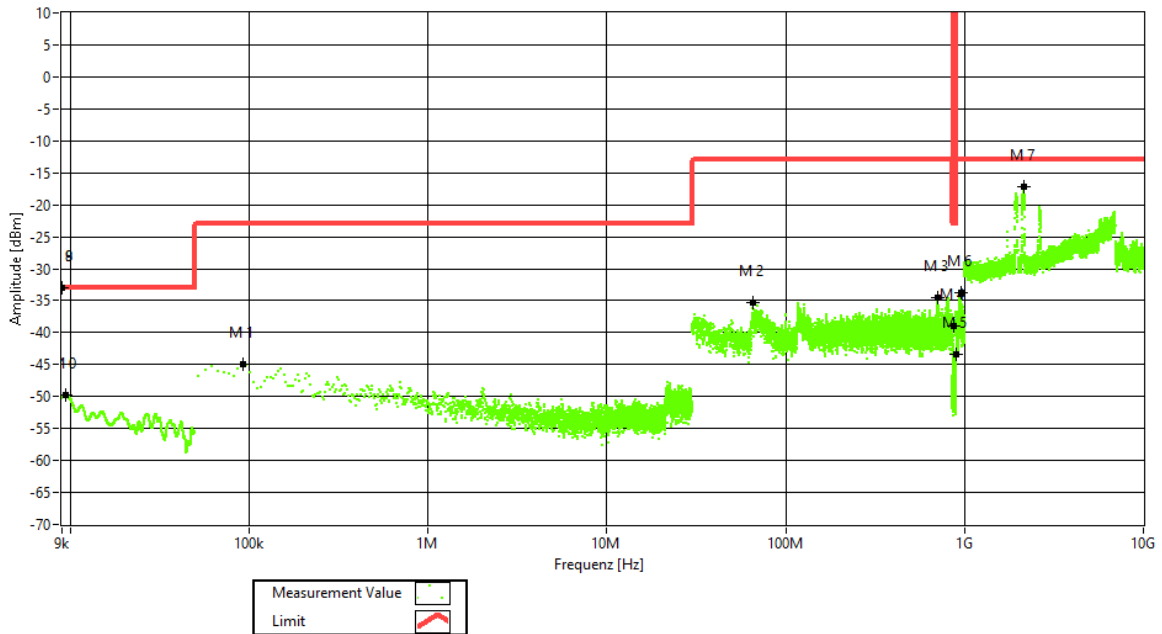

Frequency Band = Band 5, 869MHz - 894 MHz, Test Frequency = mid, Direction = RF
downlink, Signal Type = GSM

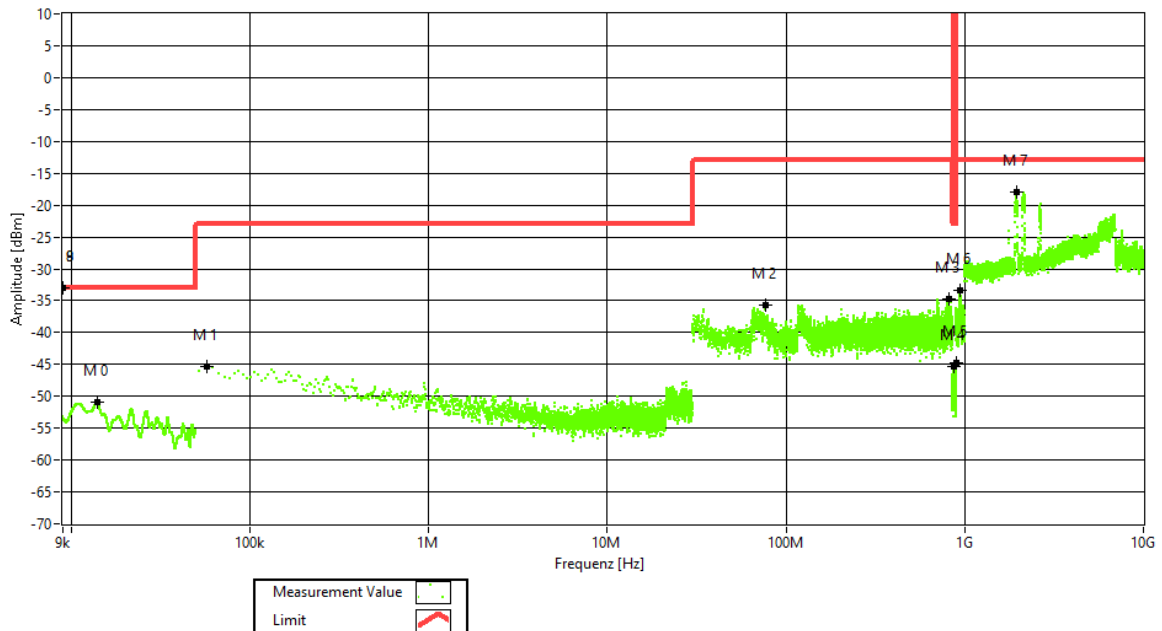



BUREAU
VERITAS

ECL-TA-20-020-V01.00

TA tests on Andrew, CAP H 80-85_17E_19_26 F-AC-
F1-APE, Band 5

Frequency Band = Band 5, 869 MHz - 894 MHz, Test Frequency = high, Direction = RF
downlink, Signal Type = GSM

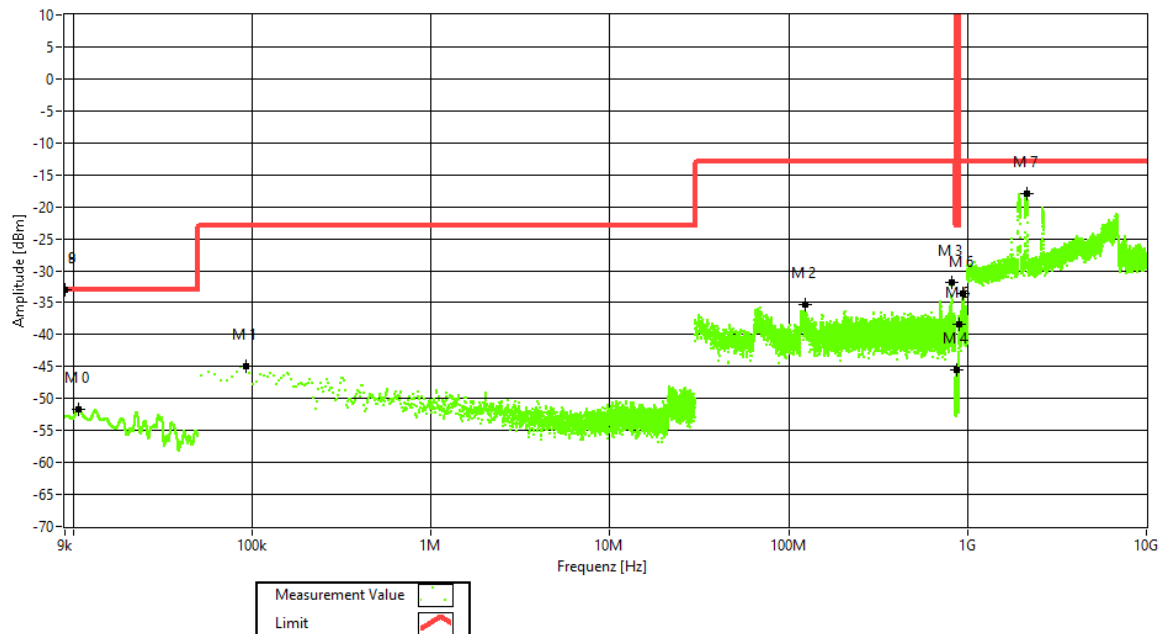

4.4.5 TEST EQUIPMENT USED

- Conducted



ECL-TA-20-020-V01.00

TA tests on Andrew, CAP H 80-85_17E_19_26 F-AC-
F1-APE, Band 5

4.5 OUT-OF-BAND EMISSION LIMITS

Standard FCC Part § 2.1051, § 22.917

The test was performed according to:
ANSI C63.26, KDB 935210 D05 v01r04: 3.6

Test date: 2020-12-14

Environmental conditions: 22 ° C; 33 % r. F.

Test engineer: Thomas Gerngroß

4.5.1 TEST DESCRIPTION

This test case is intended to demonstrate compliance to the out-of-band emission limit for industrial signal boosters. The limits itself come from the applicable rule part for each operating band per FCC § 2.1051, FCC § 22.917, and RSS-132 with subpart 5.5.

The EUT was connected to the test setup according to the following diagram:

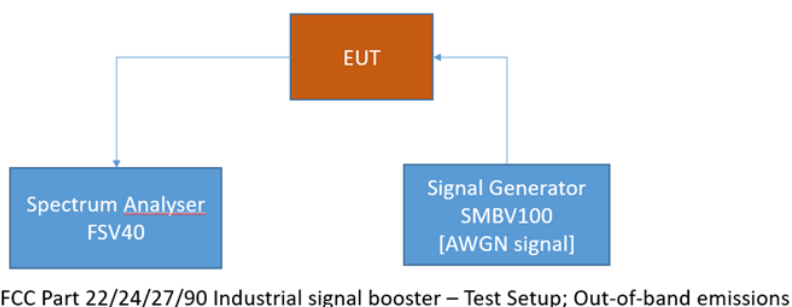

The attenuation of the measuring and stimulus path are known for each measured frequency and are considered.

The Spectrum Analyzer settings can be directly found in the measurement diagrams.



ECL-TA-20-020-V01.00

TA tests on Andrew, CAP H 80-85_17E_19_26 F-AC-
F1-APE, Band 5

4.5.2 TEST REQUIREMENTS/LIMITS

Abstract § 2.1051 from FCC:

FCC Part 2.1051; Measurement required: Spurious emissions at antenna terminal:

The radio frequency voltage or powers generated within the equipment and appearing on a spurious frequency shall be checked at the equipment output terminals when properly loaded with a suitable artificial antenna. Curves or equivalent data shall show the magnitude of each harmonic and other spurious emission that can be detected when the equipment is operated under the conditions specified in § 2.1049 as appropriate. The magnitude of spurious emissions which are attenuated more than 20 dB below the permissible value need not be specified.

Abstract § 22.917 FCC:

Part 22, Subpart H – Cellular Radiotelephone Service; Band 5

§ 22.917 Emission limitations for cellular equipment.

The rules in this section govern the spectral characteristics of emissions in the Cellular Radiotelephone Service.

(a) Out of band emissions. The power of any emission outside of the authorized operating frequency ranges must be attenuated below the transmitting power (P) by a factor of at least $43 + 10 \log(P)$ dB.

Abstract RSS-132 from ISED:

RSS-132; 5.5 Transmitter Unwanted Emissions

Mobile and base station equipment shall comply with the limits in (i) and (ii) below.

(i) In the first 1.0 MHz band immediately outside and adjacent to each of the sub-bands specified in Section 5.1, the power of emissions per any 1% of the occupied bandwidth shall be attenuated (in dB) below the transmitter output power P (dBW) by at least $43 + 10 \log_{10} p$ (watts).

(ii)

After the first 1.0 MHz immediately outside and adjacent to each of the sub-bands, the power of emissions in any 100 kHz bandwidth shall be attenuated (in dB) below the transmitter output power P (dBW) by at least $43 + 10 \log_{10} p$ (watts). If the measurement is performed using 1% of the occupied bandwidth, power integration over 100 kHz is required.



ECL-TA-20-020-V01.00

TA tests on Andrew, CAP H 80-85_17E_19_26 F-AC-
F1-APE, Band 5

4.5.3 TEST PROTOCOL

Band 5, 869 MHz - 894 MHz, downlink, Number of input signals = 1							
Signal Type	Input Power	Band Edge	Signal Frequency [MHz]	Input Power [dBm]	Maximum Out-of-band Power [dBm]	Limit Out-of-band Power [dBm]	Margin to Limit [dB]
Wideband	-0.3 dB < AGC	upper	891.50	5.9	-21.5	-13.0	8.5
Wideband	3 dB > AGC	upper	891.50	9.2	-21.0	-13.0	8.0
Narrowband	-0.3 dB < AGC	upper	893.80	5.1	-18.8	-13.0	5.8
Narrowband	3 dB > AGC	upper	893.80	8.4	-18.6	-13.0	5.6
Wideband	-0.3 dB < AGC	lower	871.50	6.1	-22.5	-13.0	9.5
Wideband	3 dB > AGC	lower	871.50	9.4	-22.8	-13.0	9.8
Narrowband	-0.3 dB < AGC	lower	869.20	5.9	-18.6	-13.0	5.6
Narrowband	3 dB > AGC	lower	869.20	9.2	-18.6	-13.0	5.6

Band 5, 869 MHz - 894 MHz, downlink, Number of input signals = 2								
Signal Type	Input Power	Band Edge	Signal Frequency f1 [MHz]	Signal Frequency f2 [MHz]	Input Power [dBm]	Maximum Out-of-band Power [dBm]	Limit Out-of-band Power [dBm]	Margin to Limit [dB]
WB	-0.3 dB < AGC	upper	891.50	889.00	5.9	-22.1	-13.0	9.1
WB	3 dB > AGC	upper	891.50	889.00	9.2	-22.3	-13.0	9.3
NB	-0.3 dB < AGC	upper	893.80	893.60	5.1	-21.5	-13.0	8.5
NB	3 dB > AGC	upper	893.80	893.60	8.4	-20.3	-13.0	7.3
WB	-0.3 dB < AGC	lower	871.50	874.00	6.1	-22.8	-13.0	9.8
WB	3 dB > AGC	lower	871.50	874.00	9.4	-22.6	-13.0	9.6
NB	-0.3 dB < AGC	lower	869.20	869.40	5.9	-27.7	-13.0	14.7
NB	3 dB > AGC	lower	869.20	869.40	9.2	-22.3	-13.0	9.3

Remark: Please see next sub-clause for the measurement plot.

Explanations concerning table with two input signals:

"WB" means Wideband.
"NB" means Narrowband.



BUREAU
VERITAS

ECL-TA-20-020-V01.00

TA tests on Andrew, CAP H 80-85_17E_19_26 F-AC-
F1-APE, Band 5

4.5.4 --2MEASUREMENT PLOT (SHOWING THE HIGHEST VALUE, "WORST CASE")

Downlink: Band 5; Frequency: 869.0000 MHz to 894.0000 MHz; Band Edge: upper; Mod: AWGN;
Input Power = 0.3 dB < AGC; Number of signals 1

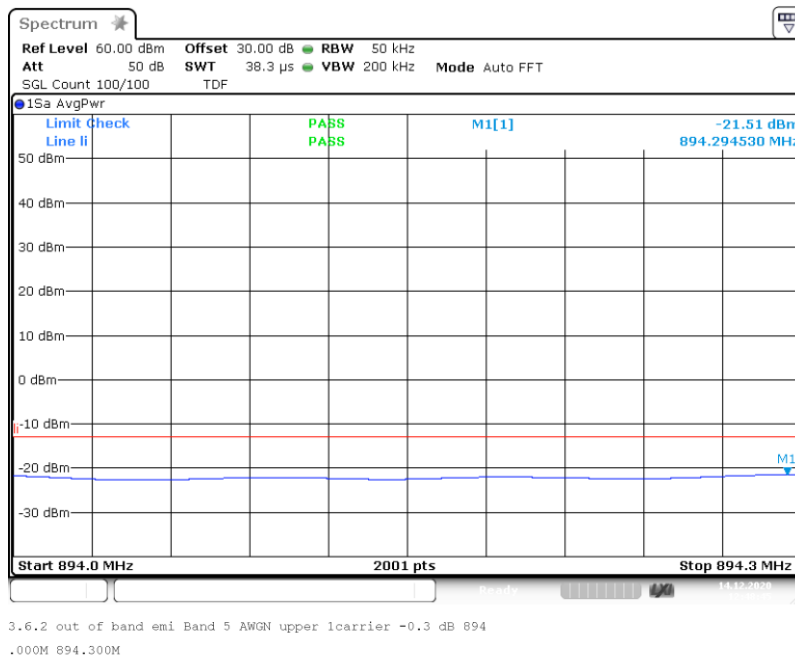

Downlink: Band 5; Frequency: 869.0000 MHz to 894.0000 MHz; Band Edge: upper; Mod: AWGN;
Input Power = 3 dB > AGC; Number of signals 1

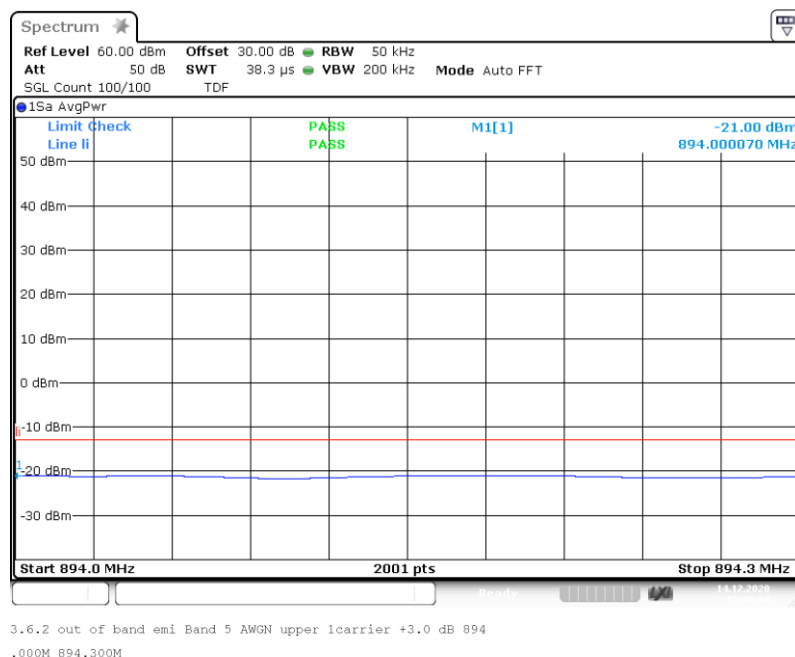



BUREAU
VERITAS

ECL-TA-20-020-V01.00

TA tests on Andrew, CAP H 80-85_17E_19_26 F-AC-
F1-APE, Band 5

Downlink: Band 5; Frequency: 869.0000 MHz to 894.0000 MHz; Band Edge: upper; Mod: GSM;
Input Power = 0.3 dB < AGC; Number of signals 1

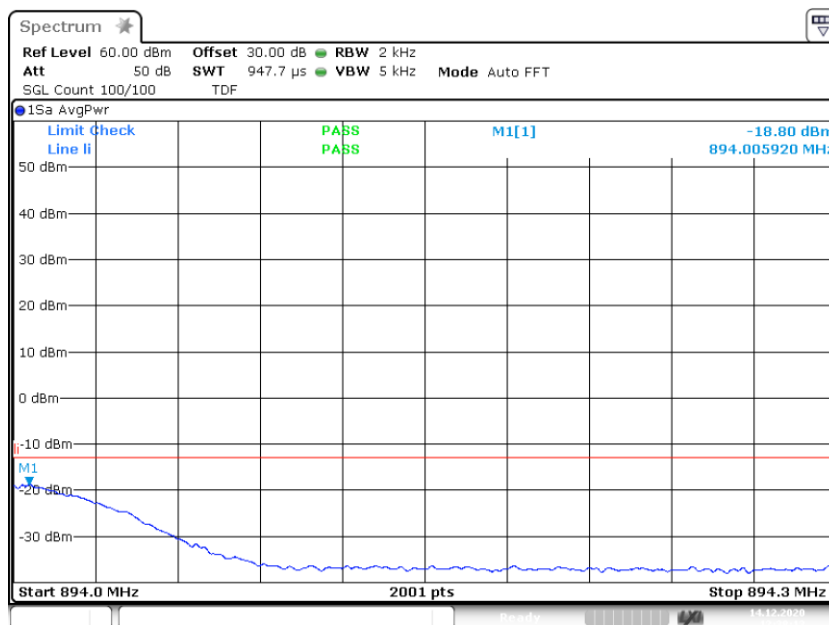

3.6.2 out of band emi Band 5 GSM upper 1carrier -0.3 dB 894.
000M 894.300M

Downlink: Band 5; Frequency: 869.0000 MHz to 894.0000 MHz; Band Edge: upper; Mod: GSM;
Input Power = 3 dB > AGC; Number of signals 1

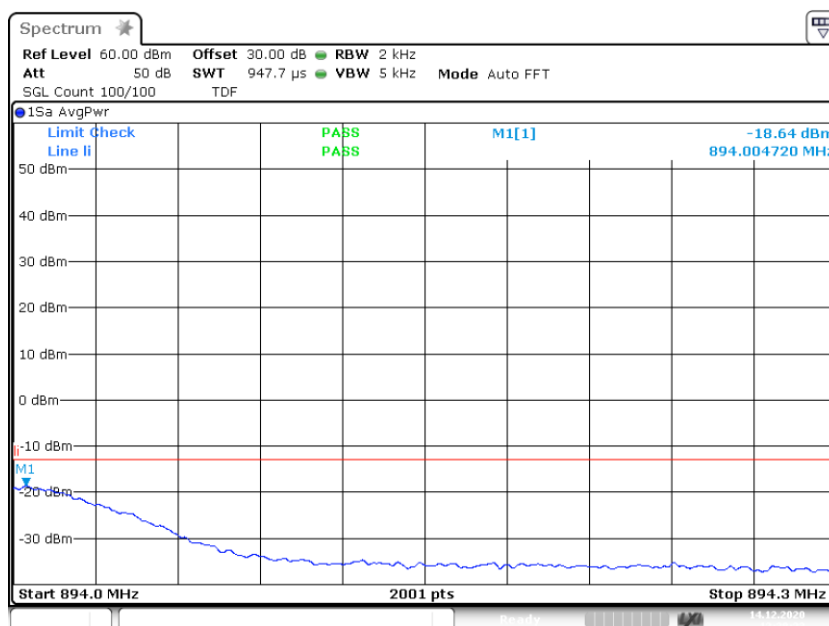

3.6.2 out of band emi Band 5 GSM upper 1carrier +3.0 dB 894.
000M 894.300M



BUREAU
VERITAS

ECL-TA-20-020-V01.00

TA tests on Andrew, CAP H 80-85_17E_19_26 F-AC-
F1-APE, Band 5

Downlink: Band 5; Frequency: 869.0000 MHz to 894.0000 MHz; Band Edge: lower; Mod: AWGN;
Input Power = 0.3 dB < AGC; Number of signals 1

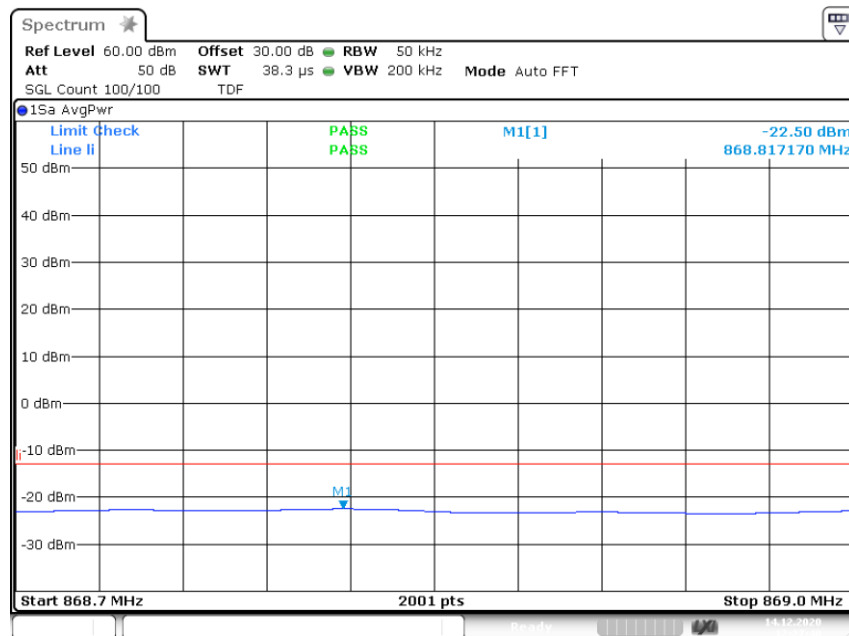

3.6.2 out of band emi Band 5 AWGN lower lcarrier -0.3 dB 868
.700M 869.000M

Downlink: Band 5; Frequency: 869.0000 MHz to 894.0000 MHz; Band Edge: lower; Mod: AWGN;
Input Power = 3 dB > AGC; Number of signals 1

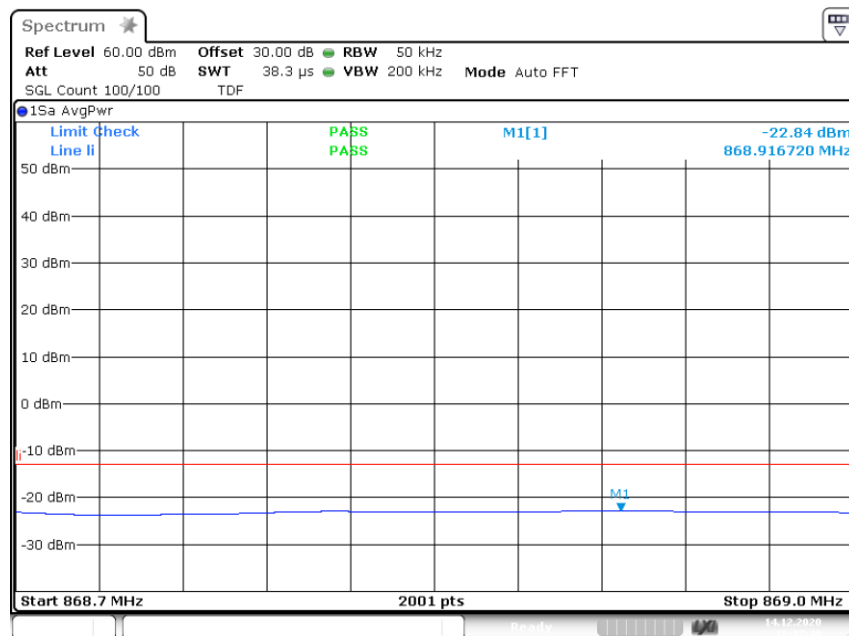

3.6.2 out of band emi Band 5 AWGN lower lcarrier +3.0 dB 868
.700M 869.000M



BUREAU
VERITAS

ECL-TA-20-020-V01.00

TA tests on Andrew, CAP H 80-85_17E_19_26 F-AC-
F1-APE, Band 5

Downlink: Band 5; Frequency: 869.0000 MHz to 894.0000 MHz; Band Edge: lower; Mod: GSM;
Input Power = 0.3 dB < AGC; Number of signals 1

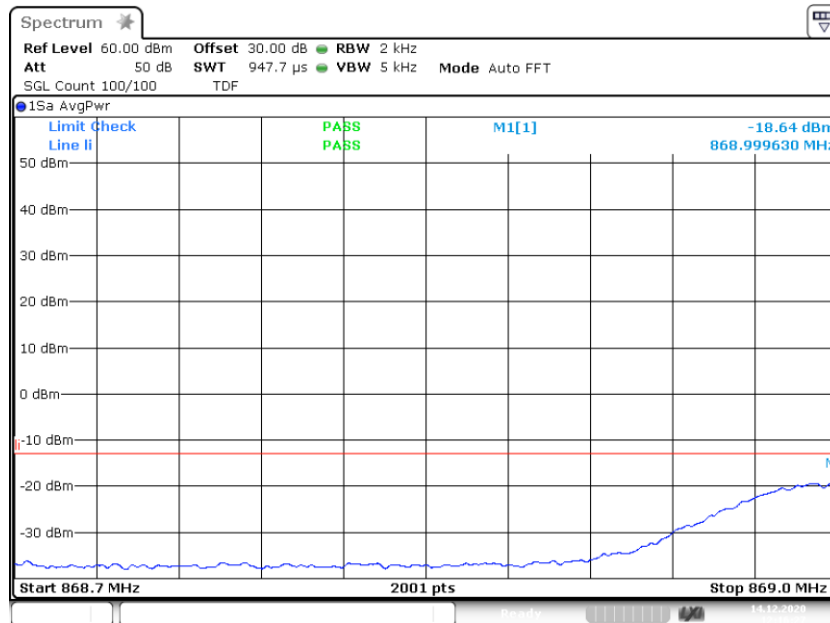

3.6.2 out of band emi Band 5 GSM lower 1carrier -0.3 dB 868.
700M 869.000M

Downlink: Band 5; Frequency: 869.0000 MHz to 894.0000 MHz; Band Edge: lower; Mod: GSM;
Input Power = 3 dB > AGC; Number of signals 1

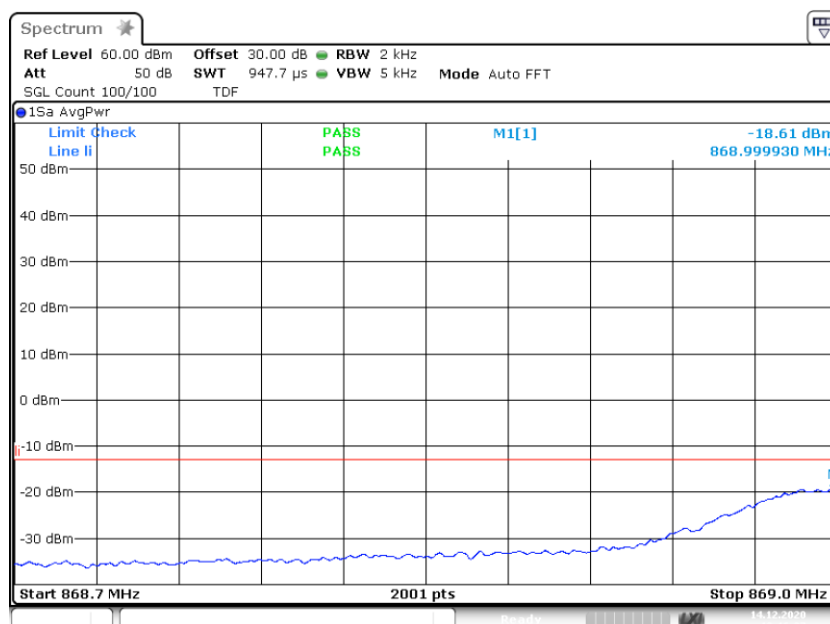

3.6.2 out of band emi Band 5 GSM lower 1carrier +3.0 dB 868.
700M 869.000M



BUREAU
VERITAS

ECL-TA-20-020-V01.00

TA tests on Andrew, CAP H 80-85_17E_19_26 F-AC-
F1-APE, Band 5

Downlink: Band 5; Frequency: 869.0000 MHz to 894.0000 MHz; Band Edge: upper; Mod: AWGN;
Input Power = 0.3 dB < AGC; Number of signals 2

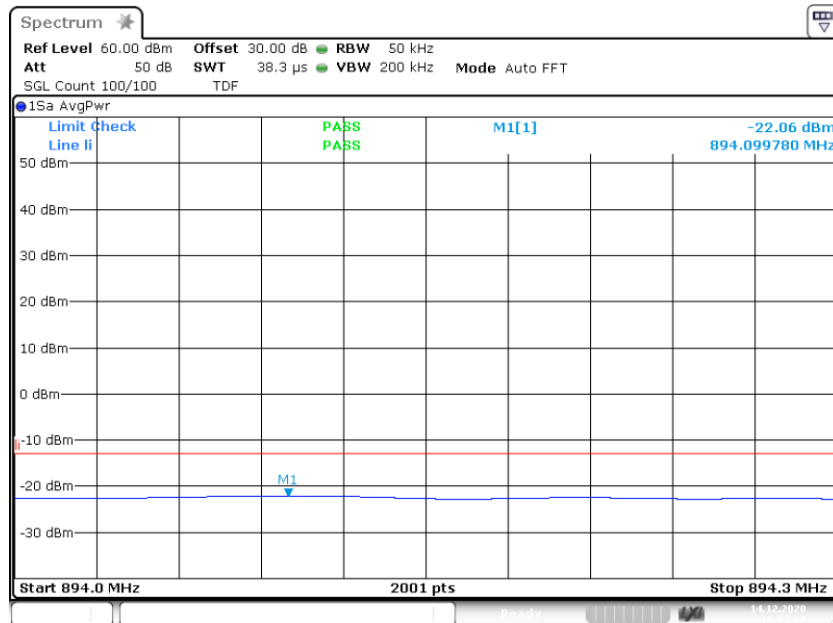

3.6.2 out of band emi Band 5 AWGN upper 2carriers -0.3 dB 89
4.000M 894.300M

Downlink: Band 5; Frequency: 869.0000 MHz to 894.0000 MHz; Band Edge: upper; Mod: AWGN;
Input Power = 3 dB > AGC; Number of signals 2

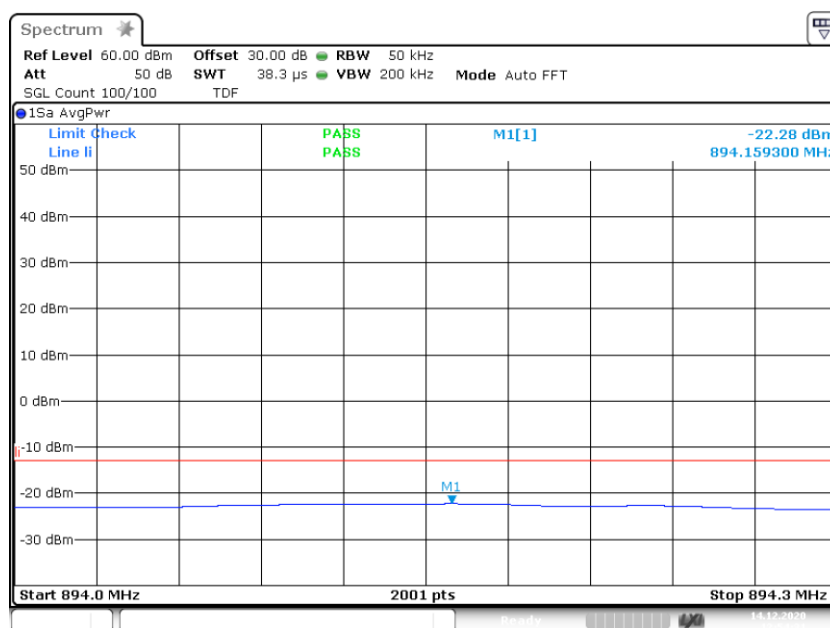

3.6.2 out of band emi Band 5 AWGN upper 2carriers +3.0 dB 89
4.000M 894.300M



BUREAU
VERITAS

ECL-TA-20-020-V01.00

TA tests on Andrew, CAP H 80-85_17E_19_26 F-AC-
F1-APE, Band 5

Downlink: Band 5; Frequency: 869.0000 MHz to 894.0000 MHz; Band Edge: lower; Mod: AWGN;
Input Power = 0.3 dB < AGC; Number of signals 2

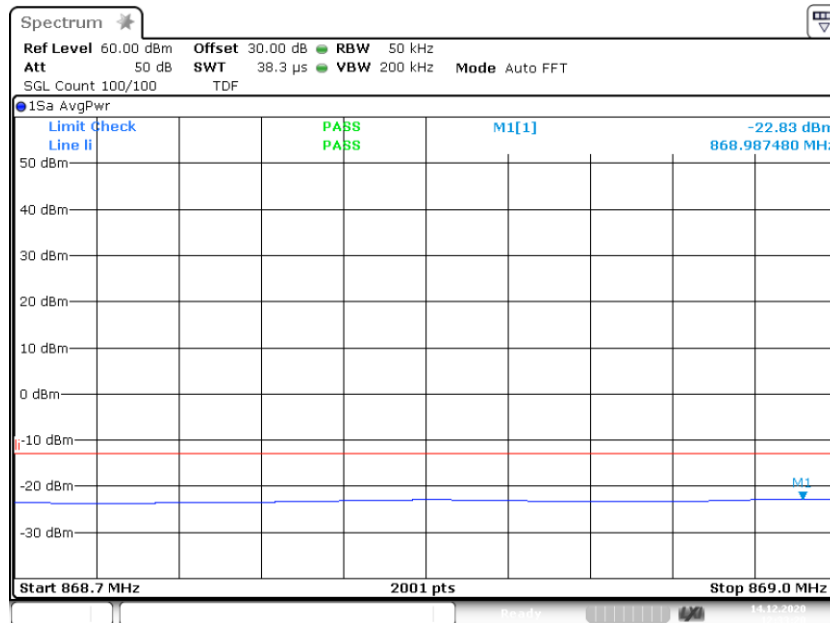

3.6.2 out of band emi Band 5 AWGN lower 2carriers -0.3 dB 86
8.700M 869.000M

Downlink: Band 5; Frequency: 869.0000 MHz to 894.0000 MHz; Band Edge: lower; Mod: AWGN;
Input Power = 3 dB > AGC; Number of signals 2

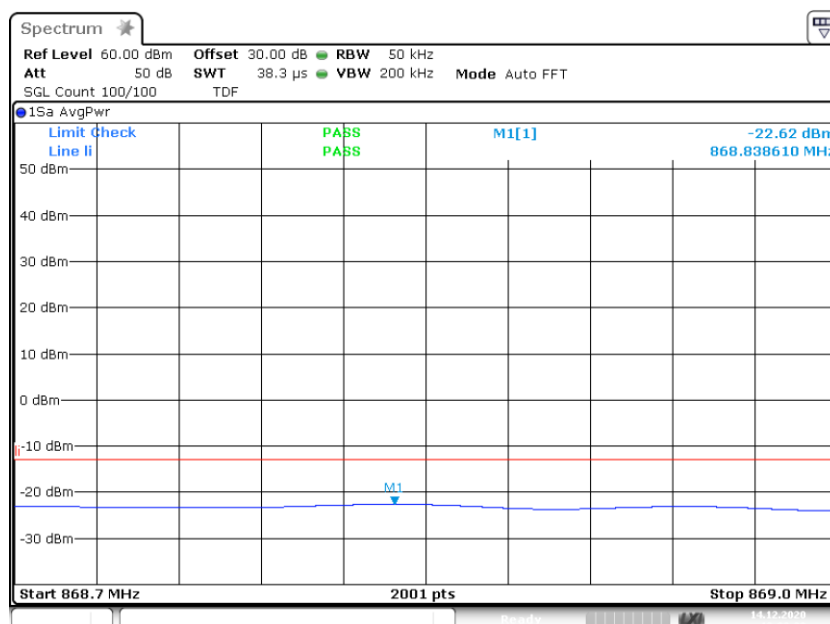

3.6.2 out of band emi Band 5 AWGN lower 2carriers +3.0 dB 86
8.700M 869.000M



BUREAU
VERITAS

ECL-TA-20-020-V01.00

TA tests on Andrew, CAP H 80-85_17E_19_26 F-AC-
F1-APE, Band 5

Downlink: Band 5; Frequency: 869.0000 MHz to 894.0000 MHz; Band Edge: lower; Mod: GSM;
Input Power = 0.3 dB < AGC; Number of signals 2

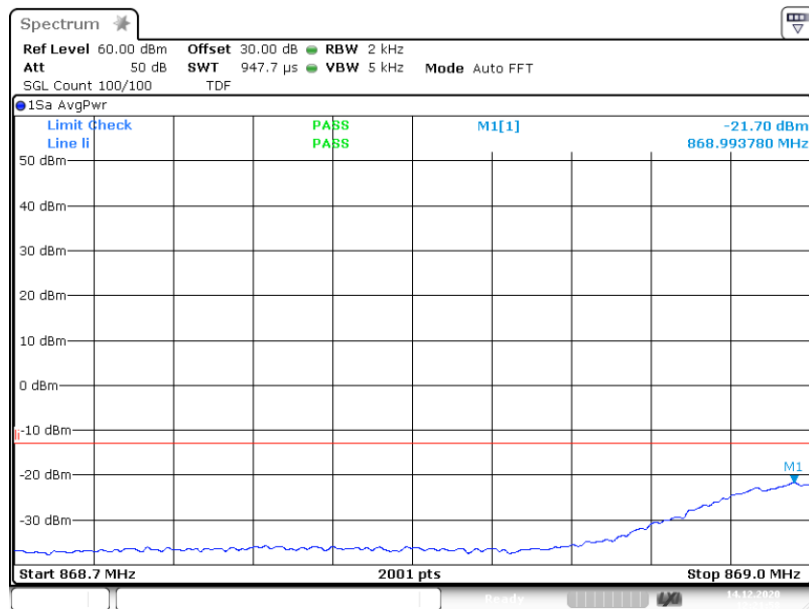

3.6.2 out of band emi Band 5 GSM lower 2carriers -0.3 dB 868
.700M 869.000M

Downlink: Band 5; Frequency: 869.0000 MHz to 894.0000 MHz; Band Edge: lower; Mod: GSM;
Input Power = 3 dB > AGC; Number of signals 2

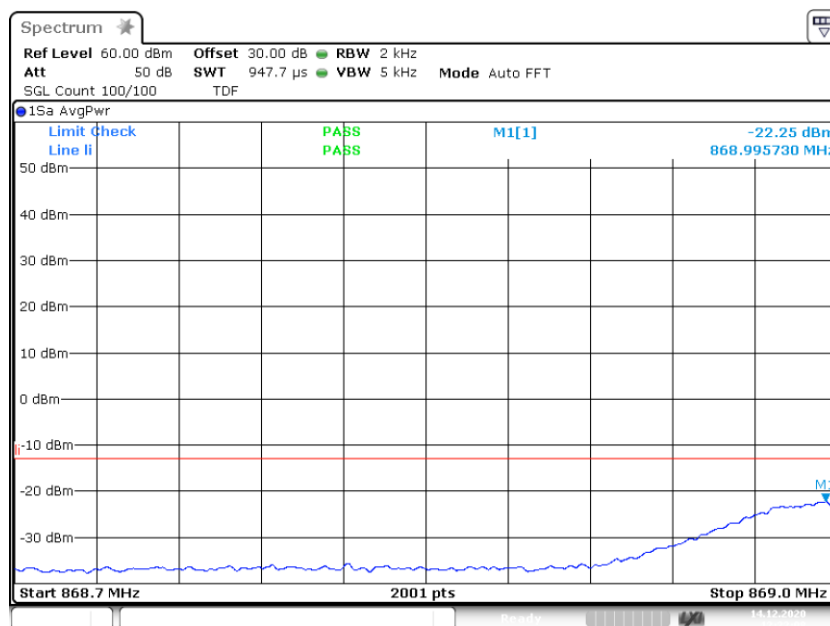

3.6.2 out of band emi Band 5 GSM lower 2carriers +3.0 dB 868
.700M 869.000M



**BUREAU
VERITAS**

ECL-TA-20-020-V01.00

TA tests on Andrew, CAP H 80-85_17E_19_26 F-AC-
F1-APE, Band 5

TEST EQUIPMENT USED

- Conducted



ECL-TA-20-020-V01.00

TA tests on Andrew, CAP H 80-85_17E_19_26 F-AC-
F1-APE, Band 5

4.6 OUT-OF-BAND REJECTION

Standard KDB 935210 D05

The test was performed according to:

ANSI C63.26; KDB 935210 D05

Test date: 2020-12-14

Environmental conditions: 22 ° C; 31 % r. F.

Test engineer: Thomas Gerngroß

4.6.1 TEST DESCRIPTION

This test case is intended to demonstrate compliance to the out-of-band rejection test case for industrial signal boosters.

The EUT was connected to the test setup according to the following diagram:

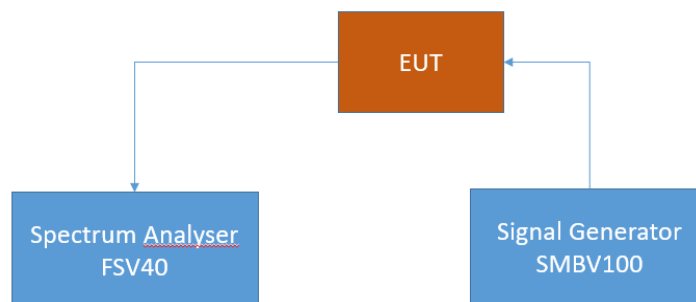

FCC Part 22/24/27/90 Industrial signal booster – Test Setup; Out-of-band rejection

The attenuation of the measuring and stimulus path are known for each measured frequency and are considered.

The Spectrum Analyzer settings can be directly found in the measurement diagrams.

4.6.2 TEST REQUIREMENTS/LIMITS

Abstract RSS-131 from ISED:

RSS-131; 5.2.1 Out-of-band rejection

The gain-versus-frequency response and the 20 dB bandwidth of the zone enhancer shall be reported. The zone enhancer shall reject amplification of other signals outside the passband of the zone enhancer.



ECL-TA-20-020-V01.00

TA tests on Andrew, CAP H 80-85_17E_19_26 F-AC-
F1-APE, Band 5

4.6.3 TEST PROTOCOL

Band 5, 869 MHz - 894 MHz, downlink				
Highest Power Frequency [MHz]	Output Power [dBm]	Lower Highest Power -20 dB Frequency [MHz]	Upper Highest Power -20 dB Frequency [MHz]	20 dB Bandwidth [MHz]
882.84	28.34	867.8690	895.1690	27.3000

Remark: Please see next sub-clause for the measurement plot.

4.6.4 MEASUREMENT PLOT (SHOWING THE HIGHEST VALUE, "WORST CASE")

Frequency Band = Band SMR, 862 MHz - 869 MHz, Direction = RF downlink

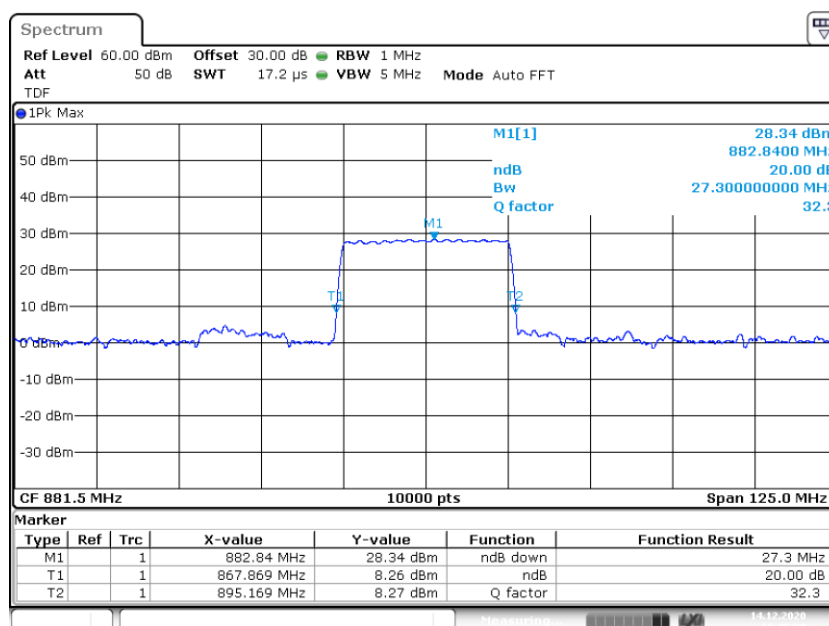

3.3 Out of band rejection Band 5 881.50000M
_20dB

4.6.5 TEST EQUIPMENT USED

- Conducted

ECL-TA-20-020-V01.00

TA tests on Andrew, CAP H 80-85_17E_19_26 F-AC-
F1-APE, Band 5

4.7 FIELD STRENGTH OF SPURIOUS RADIATION

Standard FCC Part § 2.1053, § 22.917

The test was performed according to:
ANSI C63.26

Test date: 2020-12-21; 2021-01-07

Environmental conditions: 20 ° C; 40 % r. F.

Test engineer: Thomas Hufnagel

4.7.1 TEST DESCRIPTION

This test case is intended to demonstrate compliance to the applicable radiated spurious emission measurements per FCC § 2.1053, FCC § 22.917 and RSS-132 with subpart 5.5.

The EUT was connected to the test setup according to the following diagram:

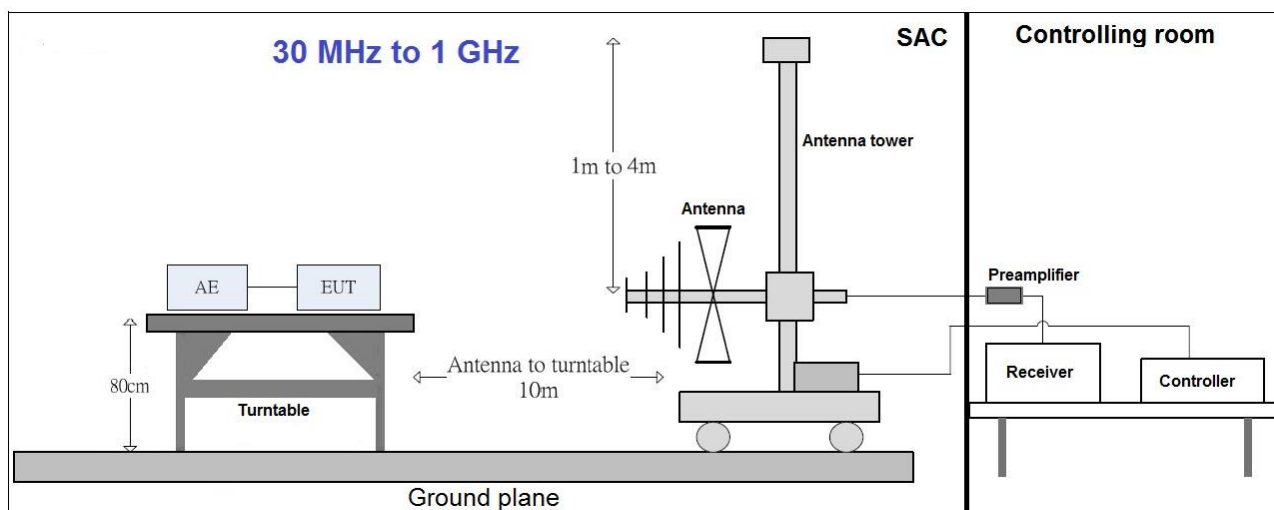

ECL-TA-20-020-V01.00

TA tests on Andrew, CAP H 80-85_17E_19_26 F-AC-
F1-APE, Band 5

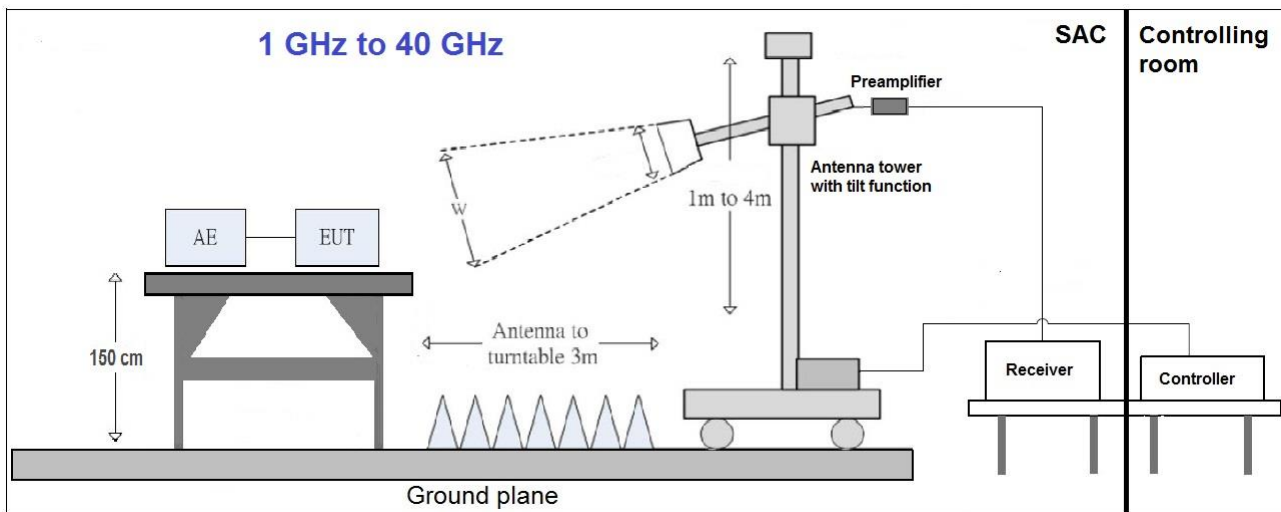

1. Measurement above 30 MHz and up to 1 GHz

The test set-up was made in accordance to the general provisions of ANSI C63.4 in a typical installation configuration. The Equipment Under Test (EUT) was set up on a non-conductive table 1.5 x 1.5 m² in the semi-anechoic chamber, 0.8 meter above the ground or floor-standing arrangement shall be placed on the horizontal ground reference plane. The influence of the EUT support table that is used between 30–1000 MHz was evaluated. For the initial measurements, the receiving antenna is varied from 1-4 meter height and is changed in the vertical plane from vertical to horizontal polarization at each frequency. The highest emissions between 30 MHz to 1000 MHz were analyzed in details by operating the spectrum analyzer and/or EMI receiver in quasi-peak mode to determine the precise amplitude of the emissions.

The measurement procedure is implemented into the EMI test software BAT EMC from NEXIO. Exploratory tests are performed at 3 orthogonal axes to determine the worst-case orientation of a body-worn or handheld EUT. The final test on all kind of EUTs is also performed at 3 axes. A pre-check is performed while the EUT is powered by a DC power source. ?

Step 1: Preliminary scan

This is a preliminary test to identify the highest amplitudes relative to the limit.

Settings for step 1:

- Antenna distance: 10 m
- Detector: Peak-Maxhold/RMS (FFT-based)
- Frequency range: 30 – 1000 MHz
- Frequency steps: 30 kHz
- IF-Bandwidth: 120 kHz
- Measuring time/Frequency step: 5 ms
- Turntable angle range: -180° to 180°
- Turntable step size: 30°
- Height variation range: 1 – 4 m
- Height variation step size: 1 m
- Polarisation: Horizontal + Vertical

Intention of this step is, to determine the radiated EMI-profile of the EUT. Afterwards the relevant emissions for the final measurement are identified.



ECL-TA-20-020-V01.00

TA tests on Andrew, CAP H 80-85_17E_19_26 F-AC-
F1-APE, Band 5

Step 2: Adjustment measurement

In this step the accuracy of the turntable azimuth and antenna height will be improved. This is necessary to find out the maximum value of every frequency.

For each frequency, which was determined the turntable azimuth and antenna height will be adjusted. The turntable azimuth will slowly vary by $\pm 45^\circ$ around this value. During this action, the value of emission is continuously measured. The turntable azimuth at the highest emission will be recorded and adjusted. In this position, the antenna height will also slowly vary by ± 100 cm around the antenna height determined. During this action, the value of emission is also continuously measured. The antenna height of the highest emission will also be recorded and adjusted.

- Detector: Peak – Maxhold; RMS
- Measured frequencies: in step 1 determined frequencies
- IF – Bandwidth: 120 kHz
- Measuring time: 100 ms
- Turntable angle range: $\pm 30^\circ$ around the determined value
- Antenna Polarisation: max. value determined in step 1

Step 3: Final measurement with QP detector

With the settings determined in step 3, the final measurement will be performed:

EMI receiver settings for step 4:

- Detector: Quasi-Peak (< 1 GHz); RMS; Peak
- Measured frequencies: in step 1 determined frequencies
- IF – Bandwidth: 120 kHz
- Measuring time: 1 s

After the measurement a plot will be generated which contains a diagram with the results of the preliminary scan and a chart with the frequencies and values of the results of the final measurement.

3. Measurement above 1 GHz

The following modifications apply to the measurement procedure for the frequency range above 1 GHz:

Step 1:

The Equipment Under Test (EUT) was set up on a non-conductive support at 1.5 m height in the semi-anechoic chamber. Absorbers are placed around and between the turn table and the antenna tower.

All steps were performed with one height (1.5 m) of the receiving antenna only.

The EUT is turned during the preliminary measurement across the elevation axis, with a step size of 30° .

The turn table step size (azimuth angle) for the preliminary measurement is 15° .

Step 2:

The maximum RFI field strength was determined during the measurement by rotating the turntable (± 180 degrees) and varying the height of the receive antenna ($h = 1 \dots 4$ m) with an additional tilt function of the antenna. The turn table azimuth will slowly vary by $\pm 15^\circ$.

EMI receiver settings (for all steps):

- Detector: Peak, Average
- IF Bandwidth = 1 MHz



**BUREAU
VERITAS**

ECL-TA-20-020-V01.00

TA tests on Andrew, CAP H 80-85_17E_19_26 F-AC-
F1-APE, Band 5

Step 3:

Spectrum analyser settings for step 3:

- Detector: Peak/Average
- Measured frequencies: in step 1 determined frequencies
- IF – Bandwidth: 1 MHz
- Measuring time: 1 s

4.7.2 TEST REQUIREMENTS/LIMITS

Abstract from FCC Part § 2.1053:

FCC Part 2.1053; Measurement required: Field strength of spurious radiation:

Measurements shall be made to detect spurious emissions that may be radiated directly from the cabinet, control circuits, power leads, or intermediate circuit elements under normal conditions of installation and operation. Curves or equivalent data shall be supplied showing the magnitude of each harmonic and other spurious emission. For this test, single sideband, independent sideband, and controlled carrier transmitters shall be modulated under the conditions specified in paragraph (c) of § 2.1049, as appropriate.

Abstract § 22.917 FCC:

Part 22, Subpart H – Cellular Radiotelephone Service; Band 5

§ 22.917 Emission limitations for cellular equipment.

The rules in this section govern the spectral characteristics of emissions in the Cellular Radiotelephone Service.

(a) Out of band emissions. The power of any emission outside of the authorized operating frequency ranges must be attenuated below the transmitting power (P) by a factor of at least $43 + 10 \log(P)$ dB.



**BUREAU
VERITAS**

ECL-TA-20-020-V01.00

TA tests on Andrew, CAP H 80-85_17E_19_26 F-AC-
F1-APE, Band 5

Abstract RSS-132 from ISED:

RSS-132; 5.5 Transmitter Unwanted Emissions

Mobile and base station equipment shall comply with the limits in (i) and (ii) below.

(i) In the first 1.0 MHz band immediately outside and adjacent to each of the sub-bands specified in Section 5.1, the power of emissions per any 1% of the occupied bandwidth shall be attenuated (in dB) below the transmitter output power P (dBW) by at least $43 + 10 \log_{10} p$ (watts).

(ii)

After the first 1.0 MHz immediately outside and adjacent to each of the sub-bands, the power of emissions in any 100 kHz bandwidth shall be attenuated (in dB) below the transmitter output power P (dBW) by at least $43 + 10 \log_{10} p$ (watts). If the measurement is performed using 1% of the occupied bandwidth, power integration over 100 kHz is required.



ECL-TA-20-020-V01.00

TA tests on Andrew, CAP H 80-85_17E_19_26 F-AC-F1-APE, Band 5

4.7.3 TEST PROTOCOL

30 MHz to 1 GHz:

Band 5, 869 MHz - 894 MHz, downlink;						
Spurious Freq. [MHz]	Spurious Level [dBm]	Pin (Sum Level) [dBm]	Detector	RBW [kHz]	Limit [dBm]	Margin to Limit [dB]
200.0	-68.3	5.4	PEAK	120	-13.0	55.3
208.2	-64.7	5.4	PEAK	120	-13.0	51.7
881.5	-42.4	5.4	PEAK	120	-13.0	29.4
200.0	-76.2	5.4	PEAK	120	-13.0	63.2
207.6	-66.9	5.4	PEAK	120	-13.0	53.9
881.5	-47.7	5.4	PEAK	120	-13.0	34.7

Above 1 GHz:

Band 5, 869 MHz - 894 MHz, downlink;						
Spurious Freq. [MHz]	Spurious Level [dBm]	Pin (Sum Level) [dBm]	Detector	RBW [kHz]	Limit [dBm]	Margin to Limit [dB]
2846.8	-43.4	5.4	PEAK	1000	-13.0	30.4
3543.8	-41.3	5.4	PEAK	1000	-13.0	28.3
8482.8	-29.9	5.4	PEAK	1000	-13.0	16.9
1720.8	-49.0	5.4	PEAK	1000	-13.0	36.0
3556.8	-41.6	5.4	PEAK	1000	-13.0	28.6
8484.0	-28.3	5.4	PEAK	1000	-13.0	15.3

Remarks: Please see next sub-clause for the measurement plot.

Although usually a RMS detector is used for measurements in this cases a PEAK detector was used.

The limits are values for use of a RMS detector, but it is so, that the use of a PEAK detector results in readings with higher measured levels. Because the levels with the higher values with PEAK detector are in tolerance, the limits with a RMS detector are definitely also in tolerance.



ECL-TA-20-020-V01.00

TA tests on Andrew, CAP H 80-85_17E_19_26 F-AC-
F1-APE, Band 5

4.7.4 MEASUREMENT PLOT (SHOWING THE HIGHEST VALUE, "WORST CASE")

Frequency Band = Band 5, 869 MHz - 894 MHz, Test Frequency = low, Direction = RF downlink

30 MHz - 1 GHz

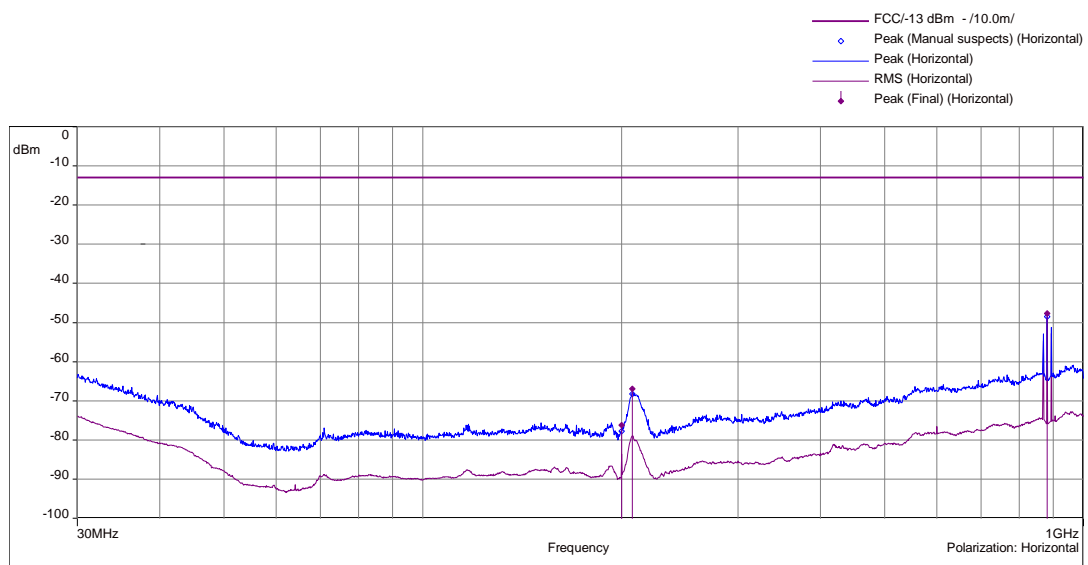
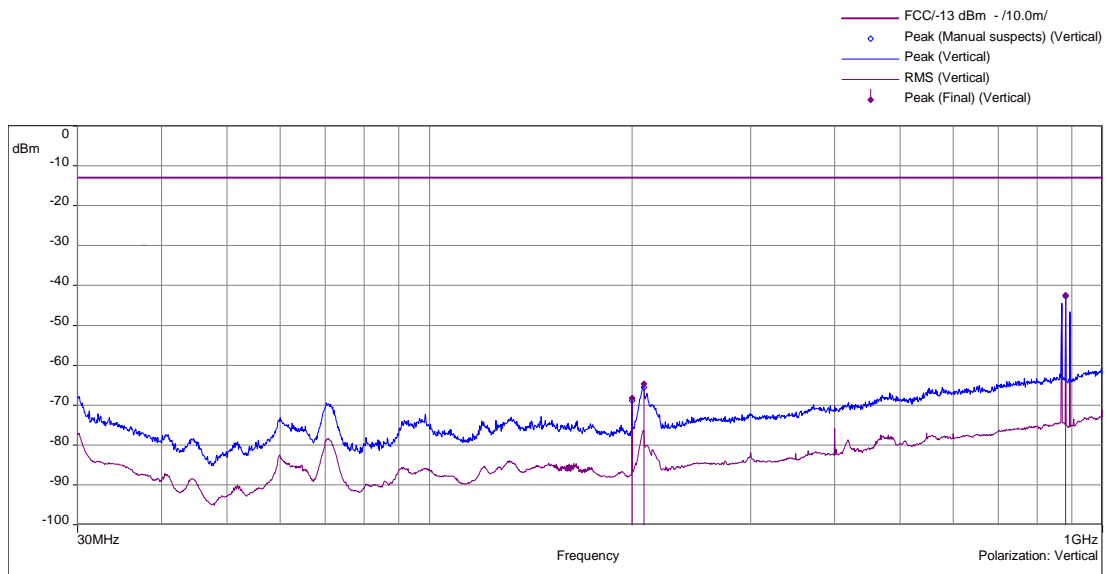



BUREAU
VERITAS

ECL-TA-20-020-V01.00

TA tests on Andrew, CAP H 80-85_17E_19_26 F-AC-
F1-APE, Band 5

1 GHz - 18 GHz

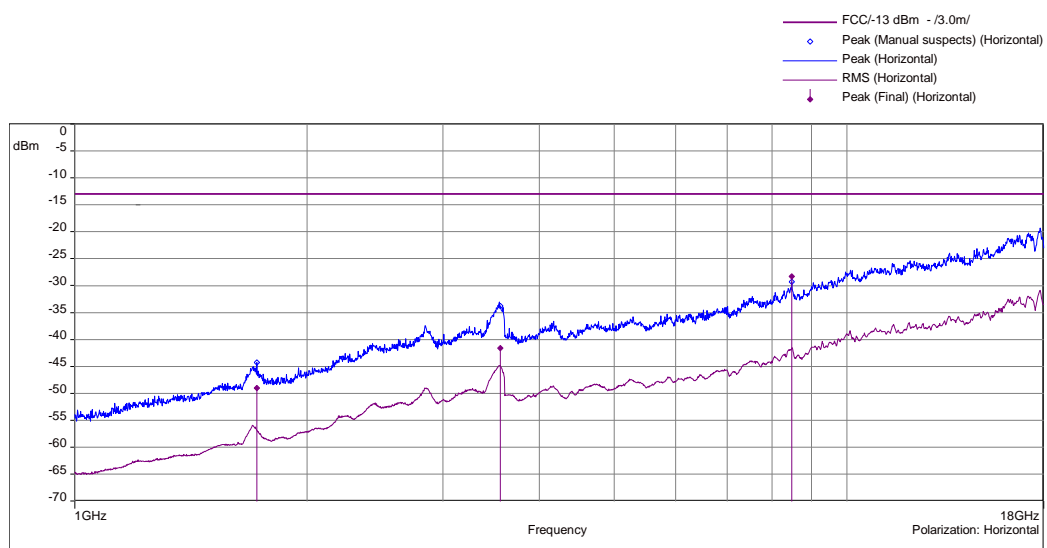
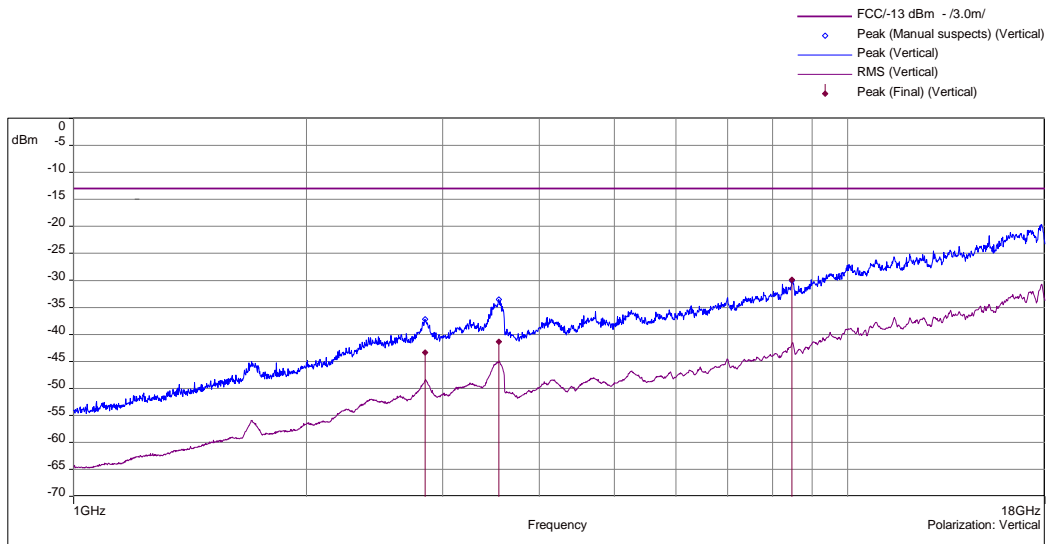



**BUREAU
VERITAS**

ECL-TA-20-020-V01.00

TA tests on Andrew, CAP H 80-85_17E_19_26 F-AC-
F1-APE, Band 5

4.7.5 FIELD STRENGTH CALCULATIONS

$$\mathbf{FS} = \mathbf{SA} + \mathbf{AF} + \mathbf{CL} + \mathbf{PA}$$

Where as:

- FS** = Field strength
- SA** = EMC test receiver reading
- AF** = Antenna factor
- CL** = Cable loss
- PA** = Preamplifier

4.7.6 TEST EQUIPMENT USED

- Radiated Emissions



ECL-TA-20-020-V01.00

TA tests on Andrew, CAP H 80-85_17E_19_26 F-AC-

F1-APE, Band 5

5 TEST EQUIPMENT

1 Conducted

Ref.No.	Type	Description	Manufacturer	Inventory no.	Last Calibration	Calibration Due
1.1	FSV40	Signal Analyzer 10 Hz - 40 GHz	Rohde & Schwarz	E2050	2020-12	2021-12
1.2	SMBV100A	Vector Signal Generator 9 kHz - 6 GHz	Rohde & Schwarz	G2089	2020-08	2022-08
1.3	KlimaLogg Pro	Thermo-Hygrometer	TFA	X546	2020-05	2021-05

2 Radiated Emissions

Ref.No.	Type	Description	Manufacturer	Inventory no.	Last Calibration	Calibration Due
2.1	ESU40	EMI test receiver 10 Hz - 40 GHz	Rohde & Schwarz	E2025	2020-12	2021-12
2.2	SMBV100A	Vector Signal Generator 9 kHz - 6 GHz	Rohde & Schwarz	G2089	2020-08	2022-08
2.3	CBL 6111C	Antenna 30 MHz - 1 GHz	Chase	K1026	2020-01	2021-01
2.4	HL 025	Antenna 1 GHz - 18 GHz	Rohde & Schwarz	K1114	2019-06	2021-06
2.5	AM1431	Pre amplifier 10 kHz - 1 GHz	Miteq	K1721	2020-12	2021-12
2.6	AFS4-00102000	Preamplifier 100 MHz - 20 GHz	Miteq	K838	2010-12	2021-12
2.7	30.3015	ThermoHygro Datalogger	TFA	X 507	2018-08	2021-08
2.8	BAT-EMC	Software	Nexio	V3.20.0.10	---	---



ECL-TA-20-020-V01.00

TA tests on Andrew, CAP H 80-85_17E_19_26 F-AC-
F1-APE, Band 5

6 ANTENNA FACTORS, CABLE LOSS AND SAMPLE CALCULATIONS

This chapter contains the antenna factors with their corresponding path loss of the used measurement path for all antennas.

6.1 ANTENNA CHASE CBL 6111C (30 MHZ – 1 GHZ)

(d = 10 m)

Frequency	AF Horizontal R&S CBL 6111C	AF Vertikal R&S CBL 6111C	Corr.
30	47.9	38.1	-38.1
50	34.4	26.4	-38.0
100	31.6	32.8	-38.0
150	33.7	33.9	-37.9
200	30.3	32.8	-37.7
250	33.6	36.5	-37.5
300	34.5	36.8	-37.1
350	36.3	37.2	-37.0
400	36.9	38.3	-36.8
450	38.0	39.6	-36.5
500	39.2	40.4	-36.0
550	41.2	42.1	-35.9
600	41.6	41.7	-35.7
650	41.9	42.9	-35.9
700	42.3	43.4	-35.6
750	43.5	43.9	-35.7
800	43.6	44.6	-36.0
850	45.0	45.1	-36.1
900	45.2	45.1	-36.6
950	46.4	46.4	-36.4
1000	45.8	47.0	-36.0

cable loss (antenna - pre-amp)	pre-amp	cable loss (inside chamber)	cable loss (to receiver)
-0,01	-38.3	0.0	0.1
0,28	-38.4	0.3	0.1
0,52	-38.7	0.5	0.2
0,73	-38.8	0.7	0.2
0,95	-38.9	1.0	0.3
1,10	-38.9	1.1	0.3
1,20	-38.6	1.2	0.3
1,29	-38.6	1.3	0.3
1,36	-38.5	1.4	0.3
1,42	-38.2	1.4	0.4
1,48	-37.9	1.5	0.4
1,54	-37.8	1.5	0.4
1,60	-37.7	1.6	0.4
1,64	-38.0	1.6	0.5
1,71	-37.8	1.7	0.5
1,76	-38.0	1.8	0.5
1,80	-38.3	1.8	0.5
1,84	-38.4	1.8	0.5
1,91	-39.0	1.9	0.5
1,93	-38.9	1.9	0.6
1,99	-38.6	2.0	0.6

Sample calculation

$E \text{ (dB } \mu\text{V/m)} = U \text{ (dB } \mu\text{V)} + AF \text{ (dB 1/m)} + Corr. \text{ (dB)}$
 U = Receiver reading
 AF = Antenna factor
 Corr. = sum of single correction factors of used cables, switch unit, distance correction, amplifier (if applicable)
 distance correction = $-20 * \text{LOG} (d_{\text{Limit}} / d_{\text{used}})$
 Linear interpolation will be used for frequencies in between the values in the table.
 Tables show an extract of values.



ECL-TA-20-020-V01.00

TA tests on Andrew, CAP H 80-85_17E_19_26 F-AC-F1-APE, Band 5

6.2 ANTENNA ROHDE & SCHWARZ HL 025 (1 GHZ – 18 GHZ)

Frequency	AF R&S HL 025	Corr.
MHz	dB (1/m)	dB
1000	33.2	-18.9
2000	39.4	-17.8
3000	42.8	-17.0
4000	45.1	-16.6
5000	46.8	-16.6
6000	48.5	-16.7
7000	50.2	-16.2
8000	50.4	-15.3
9000	51.9	-14.4
10000	53.8	-14.0
11000	54.5	-14.1
12000	55.3	-14.4
13000	55.7	-14.7
14000	56.5	-14.8
15000	56.4	-14.7
16000	57.2	-14.3
17000	57.6	-14.5
18000	57.6	-14.6

pre-amp	cable loss (to receiver)
dB	dB
-20.92	2.01
-20.60	2.78
-20.44	3.42
-20.58	3.99
-21.08	4.46
-21.53	4.87
-21.53	5.35
-20.97	5.66
-20.44	6.05
-20.43	6.45
-20.84	6.69
-21.41	7.04
-22.09	7.36
-22.48	7.66
-22.56	7.90
-22.49	8.20
-22.90	8.45
-23.27	8.71

Sample calculation

$E \text{ (dB } \mu\text{V/m)} = U \text{ (dB } \mu\text{V)} + AF \text{ (dB 1/m)} + Corr. \text{ (dB)}$
 U = Receiver reading
 AF = Antenna factor
 Corr. = sum of single correction factors of used cables, switch unit, distance correction, amplifier (if applicable)
 Linear interpolation will be used for frequencies in between the values in the table.
 Tables show an extract of values.



ECL-TA-20-020-V01.00

TA tests on Andrew, CAP H 80-85_17E_19_26 F-AC-
F1-APE, Band 5

7 MEASUREMENT UNCERTAINTIES

KDB 935210 D05	ECL
Power measurement	0,68 dB
Measuring AGC threshold level	0,90 dB
Out of band rejection	0,90 dB
Input-versus-output signal comparison	0,91 dB
Mean power output	0,90 dB
Measuring out-of-band/out-of-block (including intermodulation) emissions and spurious emissions	0,90 dB
Out-of-band/out-of-block emissions conducted measurements	0,90 dB
Spurious emissions conducted	2,18 dB
Spurious emissions radiated measurements	5,38 dB
Total frequency uncertainty	2×10^{-7}

Reference :

ECL-MU5.4.6.3-EMC-14-001-V03.00 MU Wireless.xlsx



ECL-TA-20-020-V01.00

TA tests on Andrew, CAP H 80-85_17E_19_26 F-AC-
F1-APE, Band 5

ANNEX A: ACCREDITATION CERTIFICATE (FOR INFORMATION)

The accreditation relates to competences stated on the accreditation certificate. The current certificate is available on the homepage of the DAkkS and can be downloaded under accredited bodies with the processing number:

<https://www.dakks.de/en>



**BUREAU
VERITAS**

ECL-TA-20-020-V01.00

TA tests on Andrew, CAP H 80-85_17E_19_26 F-AC-
F1-APE, Band 5

ANNEX B: ADDITIONAL INFORMATION PROVIDED BY CLIENT

None.

ECL-TA-20-020-V01.00

TA tests on Andrew, CAP H 80-85_17E_19_26 F-AC-
F1-APE, Band 5

ANNEX C: PHOTO REPORT

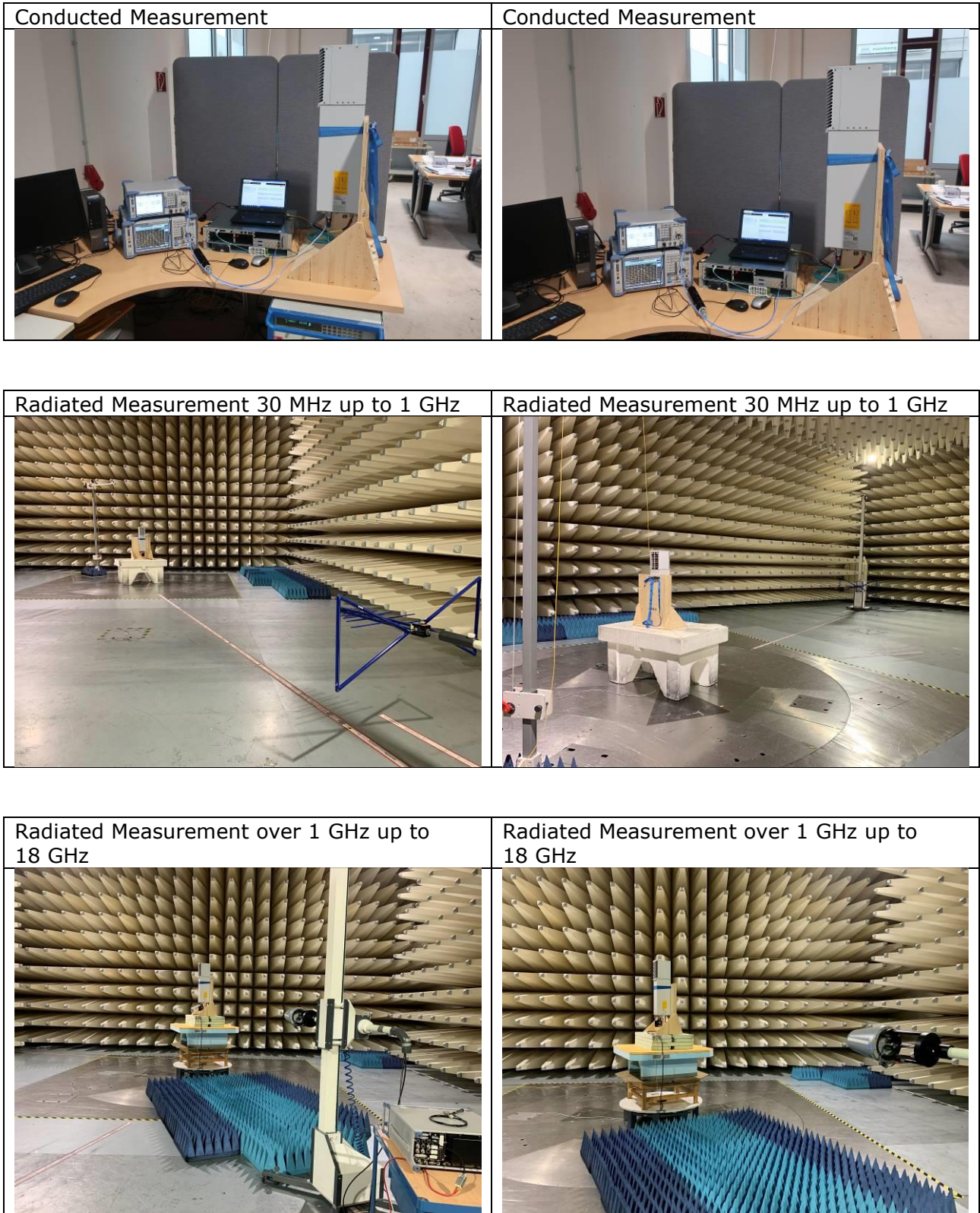



**BUREAU
VERITAS**

ECL-TA-20-020-V01.00

TA tests on Andrew, CAP H 80-85_17E_19_26 F-AC-
F1-APE, Band 5

***** End of test report *****