



# CERTIFICATION TEST REPORT

**Report Number. :** 12804406-E1V3

**Applicant :** FITBIT INC.  
199 FREMONT ST, 14TH FLOOR  
SAN FRANCISCO, CA 94105, U.S.A

**Model :** FB507

**Brand :** FitBit

**FCC ID :** XRAFB507

**IC :** 8542A-FB507

**EUT Description :** SMARTWATCH

**Test Standard(s) :** FCC 47 CFR PART 15 SUBPART C  
ISED RSS-210 ISSUE 9  
ISED RSS-GEN ISSUE 5

**Date Of Issue:**

June 27, 2019

**Prepared by:**

UL Verification Services Inc.  
47173 Benicia Street  
Fremont, CA 94538, U.S.A.  
TEL: (510) 319-4000  
FAX: (510) 661-0888



NVLAP Lab code: 200065-0

**REPORT REVISION HISTORY**

<u>Rev.</u>	<u>Issue Date</u>	<u>Revisions</u>	<u>Revised By</u>
V1	6/6/2019	Initial Issue	--
V2	6/24/2019	Revised Section 8.1 to address TCB's question	Tina Chu
V3	6/27/2019	Revised Section 5.2 and Section 9 to address TCB's question	Tina Chu

## TABLE OF CONTENTS

<b>1. ATTESTATION OF TEST RESULTS .....</b>	<b>4</b>
<b>2. TEST METHODOLOGY .....</b>	<b>6</b>
<b>3. FACILITIES AND ACCREDITATION .....</b>	<b>6</b>
<b>4. CALIBRATION AND UNCERTAINTY .....</b>	<b>7</b>
4.1. <i>MEASURING INSTRUMENT CALIBRATION .....</i>	<i>7</i>
4.2. <i>SAMPLE CALCULATION .....</i>	<i>7</i>
4.3. <i>MEASUREMENT UNCERTAINTY.....</i>	<i>7</i>
<b>5. EQUIPMENT UNDER TEST .....</b>	<b>8</b>
5.1. <i>DESCRIPTION OF EUT .....</i>	<i>8</i>
5.2. <i>MAXIMUM OUTPUT POWER.....</i>	<i>8</i>
5.3. <i>DESCRIPTION OF AVAILABLE ANTENNAS .....</i>	<i>8</i>
5.4. <i>SOFTWARE AND FIRMWARE.....</i>	<i>8</i>
5.5. <i>WORST-CASE CONFIGURATION AND MODE.....</i>	<i>8</i>
5.6. <i>DESCRIPTION OF TEST SETUP.....</i>	<i>9</i>
<b>6. TEST AND MEASUREMENT EQUIPMENT .....</b>	<b>10</b>
<b>7. ANTENNA PORT TEST RESULTS .....</b>	<b>11</b>
7.1. <i>OCCUPIED BANDWIDTH .....</i>	<i>11</i>
<b>8. RADIATED EMISSION TEST RESULTS.....</b>	<b>12</b>
8.1. <i>LIMITS AND PROCEDURE.....</i>	<i>12</i>
8.1.1. <i>FUNDAMENTAL EMISSION MASK (11.56 – 15.56MHz).....</i>	<i>14</i>
8.1.2. <i>TRANSMITTER (0.09 – 30MHz).....</i>	<i>15</i>
8.1.3. <i>TRANSMITTER (30 – 1000MHz) HARMONICS AND SPURIOUS EMISSIONS ..</i>	<i>16</i>
<b>9. FREQUENCY STABILITY .....</b>	<b>18</b>
<b>10. SETUP PHOTOS .....</b>	<b>19</b>

## 1. ATTESTATION OF TEST RESULTS

**COMPANY NAME:** FITBIT INC.  
199 FREMONT ST, 14<sup>TH</sup> FLOOR  
SAN FRANCISCO,  
CA 94105, U.S.A

**EUT DESCRIPTION:** SMARTWATCH

**MODEL:** FB507

**SERIAL NUMBER:** 23 60 7F C6 B0 21; 23 3F 1E 46 B0 21

**DATE TESTED:** APRIL 29, 2019 - MAY 31, 2019

APPLICABLE STANDARDS	
STANDARD	TEST RESULTS
FCC PART 15 SUBPART C	Complies
ISED RSS-210 Issue 9, Annex B.6.	Complies
ISED RSS-GEN Issue 5	Complies

UL Verification Services Inc. tested the above equipment in accordance with the requirements set forth in the above standards. The test results show that the equipment tested is capable of demonstrating compliance with the requirements as documented in this report.

The results documented in this report apply only to the tested sample, under the conditions and modes of operation as described herein. It is the manufacturer's responsibility to assure that additional production units of this model are manufactured with identical electrical and mechanical components. All samples tested were in good operating condition throughout the entire test program. Measurement Uncertainties are published for informational purposes only and were not taken into account unless noted otherwise.

This document may not be altered or revised in any way unless done so by UL Verification Services Inc. and all revisions are duly noted in the revisions section. Any alteration of this document not carried out by UL Verification Services Inc. will constitute fraud and shall nullify the document. This report must not be used by the client to claim product certification, approval, or endorsement by NVLAP, NIST, any agency of the Federal Government, or any agency of the U.S. government.

Approved & Released For  
UL Verification Services Inc. By:



---

FRANCISCO DE ANDA  
PROJECT LEAD  
UL Verification Services Inc.

Prepared By:



---

ERIC YU  
TEST ENGINEER  
UL Verification Services Inc.

Reviewed By:



---

TINA CHU  
SENIOR PROJECT ENGINEER  
UL Verification Services Inc.

## 2. TEST METHODOLOGY

The tests documented in this report were performed in accordance with ANSI C63.10-2013, FCC CFR 47 Part 2, FCC CFR 47 Part 15, RSS-GEN Issue 5 Amendment 1, and RSS-210 Issue 9.

## 3. FACILITIES AND ACCREDITATION

The test sites and measurement facilities used to collect data are located at 47173 and 47266 Benicia Street, and 47658 Kato Road, Fremont, California, USA. Line conducted emissions are measured only at the 47173 address. The following table identifies which facilities were utilized for radiated emission measurements documented in this report. Specific facilities are also identified in the test results sections.

47173 Benicia Street	47266 Benicia Street	47658 Kato Road
<input type="checkbox"/> Chamber A	<input type="checkbox"/> Chamber D	<input checked="" type="checkbox"/> Chamber I
<input type="checkbox"/> Chamber B	<input type="checkbox"/> Chamber E	<input checked="" type="checkbox"/> Chamber J
<input type="checkbox"/> Chamber C	<input type="checkbox"/> Chamber F	<input checked="" type="checkbox"/> Chamber K
	<input type="checkbox"/> Chamber G	<input type="checkbox"/> Chamber L
	<input type="checkbox"/> Chamber H	<input type="checkbox"/> Chamber M

The above test sites and facilities are covered under FCC Test Firm Registration # 208313. Chambers above are covered under Industry Canada company address and respective code: 2324A.

UL Verification Services Inc. is accredited by NVLAP, Laboratory Code 200065-0

## 4. CALIBRATION AND UNCERTAINTY

### 4.1. MEASURING INSTRUMENT CALIBRATION

The measuring equipment utilized to perform the tests documented in this report has been calibrated in accordance with the manufacturer's recommendations, and is traceable to recognized national standards.

### 4.2. SAMPLE CALCULATION

#### RADIATED EMISSIONS

Where relevant, the following sample calculation is provided:

$$\text{Field Strength (dBuV/m)} = \text{Measured Voltage (dBuV)} + \text{Antenna Factor (dB/m)} + \text{Cable Loss (dB)} - \text{Preamp Gain (dB)}$$

$$36.5 \text{ dBuV} + 18.7 \text{ dB/m} + 0.6 \text{ dB} - 26.9 \text{ dB} = 28.9 \text{ dBuV/m}$$

#### MAINS CONDUCTED EMISSIONS

Where relevant, the following sample calculation is provided:

$$\text{Final Voltage (dBuV)} = \text{Measured Voltage (dBuV)} + \text{Cable Loss (dB)} + \text{Limiter Factor (dB)} + \text{LISN Insertion Loss.}$$

$$36.5 \text{ dBuV} + 0 \text{ dB} + 10.1 \text{ dB} + 0 \text{ dB} = 46.6 \text{ dBuV}$$

### 4.3. MEASUREMENT UNCERTAINTY

Where relevant, the following measurement uncertainty levels have been estimated for tests performed on the apparatus:

PARAMETER	UNCERTAINTY
Worst Case Conducted Disturbance, 9KHz to 0.15 MHz	3.84 dB
Worst Case Conducted Disturbance, 0.15 to 30 MHz	3.65 dB
Worst Case Radiated Disturbance, 9KHz to 30 MHz	2.52 dB
Worst Case Radiated Disturbance, 30 to 1000 MHz	4.88 dB
Worst Case Radiated Disturbance, 1000 to 18000 MHz	4.24 dB
Worst Case Radiated Disturbance, 18000 to 26000 MHz	4.37 dB
Worst Case Radiated Disturbance, 26000 to 40000 MHz	5.17 dB

Uncertainty figures are valid to a confidence level of 95%.

## 5. EQUIPMENT UNDER TEST

### 5.1. DESCRIPTION OF EUT

The EUT is a smartwatch.

### 5.2. MAXIMUM OUTPUT POWER

The transmitter has a maximum peak radiated field strength as follows:

Frequency Range (MHz)	Type	E Field at 30m distance (dBuV/m)
13.56	B	2.45

### 5.3. DESCRIPTION OF AVAILABLE ANTENNAS

The EUT utilizes a coil antenna.

### 5.4. SOFTWARE AND FIRMWARE

The EUT firmware installed during testing was 35.6.0.239

The test utility software used during testing was TeraTerm

### 5.5. WORST-CASE CONFIGURATION AND MODE

Normal operating of NFC was standalone mode (without the charger); therefore, all final radiated testing was performed with this configuration and AC mains line conducted emissions is not applicable.

EUT has 1 type of plastic wristband and 3 types of metallic bands: Link, Tri-Link and Mesh. The worst-case configuration was investigated with wristbands and it was determined that EUT with Tri-Link wristband was the worst-case. In addition, the fundamental of the EUT was investigated in three orthogonal orientations X/Y/Z, it was determined that Z-Portrait orientation was worst-case orientation. Therefore, all final radiated testing was performed with the EUT in Z-Portrait orientation with Tri-Link wristband.

The data rates as provided by the client were: Type A 106, 212, 424 and 848kbps and Type B 106, 212, 424 and 848kbps. The worst-case data rate provided by client was Type B 106kbps; therefore, all final testing was performed with the Type B 106kbps.



## 5.6. DESCRIPTION OF TEST SETUP

### SUPPORT EQUIPMENT

N/A

### I/O CABLES (ANTENNA PORT AND RADIATED TEST)

N/A

### TEST SETUP- ANTENNA PORT AND RADIATED TEST

The EUT was standalone. Test software exercised the EUT.

### SETUP DIAGRAM

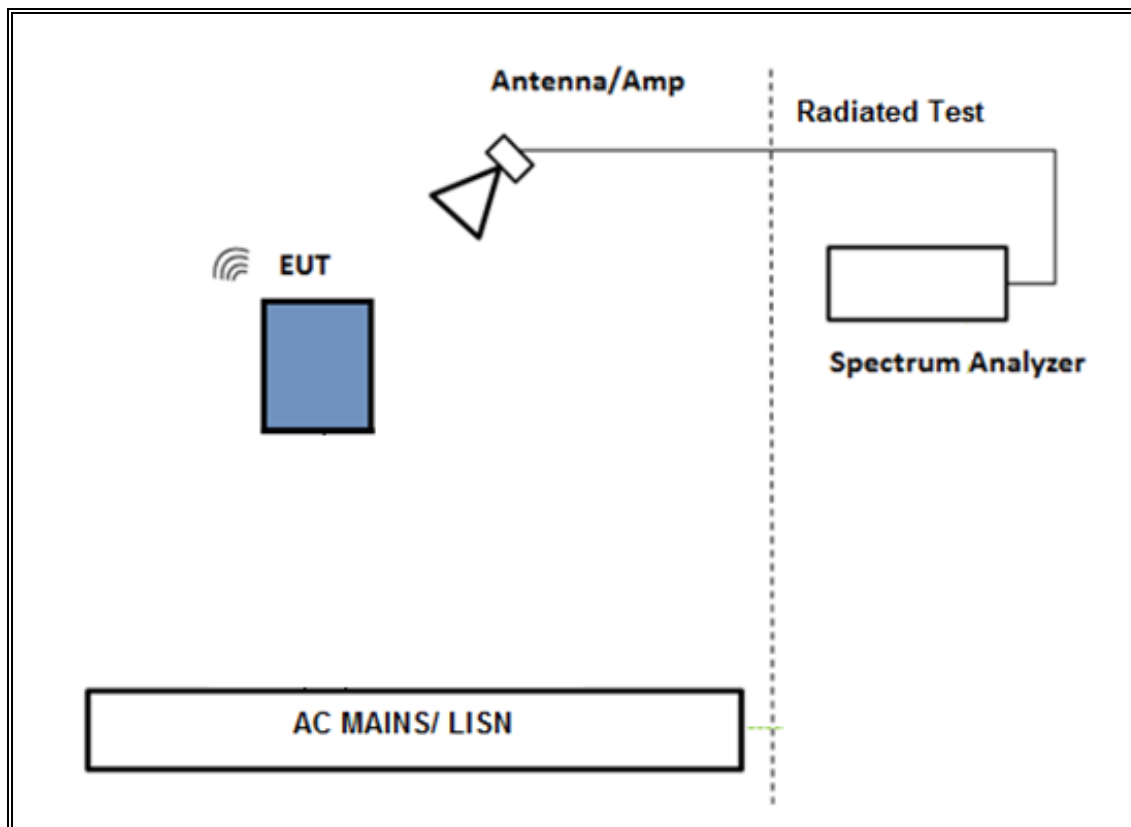

## 6. TEST AND MEASUREMENT EQUIPMENT

The following test and measurement equipment was utilized for the tests documented in this report:

TEST EQUIPMENT LIST					
Description	Manufacturer	Model	ID Num	Cal Due	Last Cal
Antenna, Passive Loop 30Hz to 1MHz	ELETRO METRICS	EM-6871	PRE0179465	05/22/2019	05/22/2018
Antenna, Passive Loop 100kHz to 30MHz	ELETRO METRICS	EM-6872	PRE0179467	05/22/2019	05/22/2018
Amplifier, 100kHz to 1GHz, 32 dB	Sonoma Instrument	310	PRE0186650	12/13/2019	12/13/2018
Hybrid Antenna, 30MHz to 3GHz	SunAR rf motion	JB3	PRE0181575	08/01/2019	08/01/2018
Amplifier, 100kHz to 1GHz, 32 dB	Sonoma Instrument	310	PRE0180174	05/31/2019	05/31/2018
EMI Test Receiver	Rohde & Schwarz	ESW44	PRE0179367	02/14/2020	02/14/2019
EMI Test Receiver	Rohde & Schwarz	ESW44	PRE0179377	02/15/2020	02/15/2019
EMI Test Receiver	Rohde & Schwarz	ESW44	PRE0179376	02/14/2020	02/14/2019
Spectrum Analyzer, PXA, 3Hz to 44GHz	Agilent (Keysight) Technologies	N9030A	T908	01/23/2020	01/23/2019
Temperature/Humidity Chamber	Thermotron	SE-600-10-10	80	05/13/2019	11/13/2019
Test Software List					
Radiated Software	UL	UL EMC		Ver 9.5, Jan 11, 2019	

## 7. ANTENNA PORT TEST RESULTS

### 7.1. OCCUPIED BANDWIDTH

#### LIMITS

For reporting purposes only

#### TEST PROCEDURE

The transmitter output is connected to the spectrum analyzer. The RBW is set to 10 kHz. The VBW is set to 3 times the RBW. The sweep time is coupled. The spectrum analyzer internal 99% bandwidth function is utilized.

Note: Because the measured signal is CW/CW-like adjusting the RBW per C63.10 would not be practical since measured bandwidth will always follow the RBW and the result will be approximately twice the RBW

#### RESULTS

Channel	Frequency (MHz)	99% Bandwidth (KHz)	20dB Bandwidth (KHz)
Low	13.56	26.33	24.87

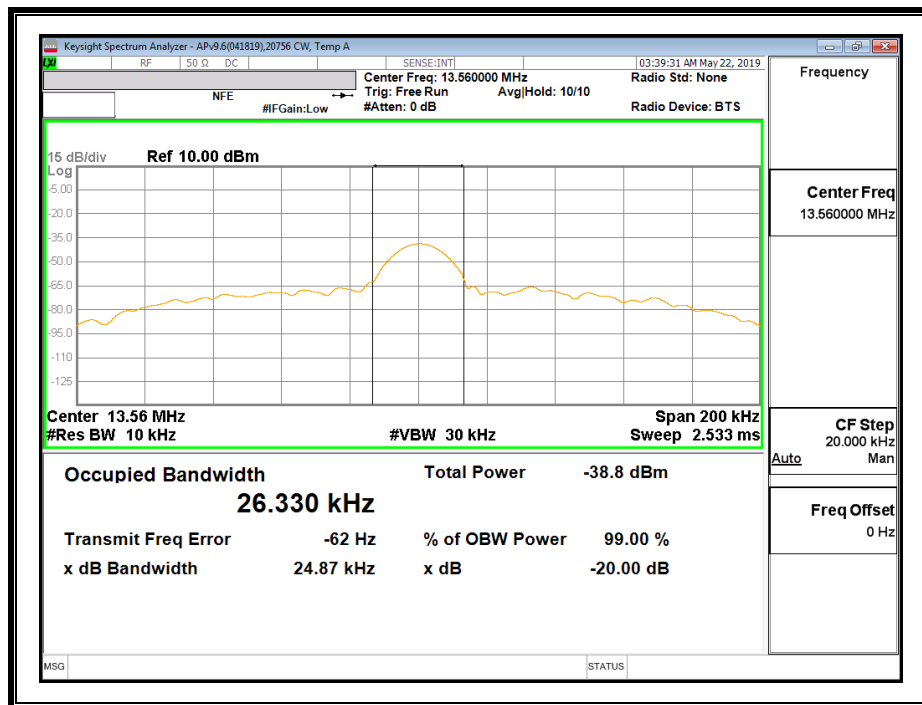

## 8. RADIATED EMISSION TEST RESULTS

### 8.1. LIMITS AND PROCEDURE

#### LIMITS

FCC§15.225  
IC RSS-210, Issue 9 Annex B.6.  
IC RSS-GEN, Section 8.9 (Transmitter)

- (a) The field strength of any emissions within the band 13.553–13.567 MHz shall not exceed 15,848 microvolts/ meter at 30 meters.
- (b) Within the bands 13.410–13.553 MHz and 13.567–13.710 MHz, the field strength of any emissions shall not exceed 334 microvolts/meter at 30 meters.
- (c) Within the bands 13.110–13.410 MHz and 13.710–14.010 MHz the field strength of any emissions shall not exceed 106 microvolts/meter at 30 meters.
- (d) The field strength of any emissions appearing outside of the 13.110– 14.010 MHz and shall not exceed the general radiated emission limits in § 15.209 as follows:  
§15.209 (a) Except as provided elsewhere in this subpart, the emissions from an intentional radiator shall not exceed the field strength levels specified in the following table:

Limits for radiated disturbance of an intentional radiator		
Frequency range (MHz)	Limits (µV/m)	Measurement Distance (m)
0.009 – 0.490	2400 / F (kHz)	300
0.490 – 1.705	24000 / F (kHz)	30
1.705 – 30.0	30	30
30 – 88	100**	3
88 - 216	150**	3
216 – 960	200**	3
Above 960	500	3

\*\* Except as provided in paragraph (g), fundamental emissions from intentional radiators operating under this section shall not be located in the frequency bands 54-72 MHz, 76-88 MHz, 174-216 MHz or 470-806MHz. However, operation within these frequency bands is permitted under other sections of this part, e.g. §§ 15.231 and 15.241.  
§15.209 (b) In the emission table above, the tighter limit applies at the band edges.

Formula for converting the filed strength from uV/m to dBuV/m is:  
Limit (dBuV/m) = 20 log limit (uV/m)

In addition:

§15.209 (d) The emission limits shown the above table are based on measurements employing a CISPR quasi-peak detector except for the frequency bands 9-90 kHz, 110-490 kHz and above 1000 MHz Radiated emissions limits in these three bands are based on measurements employing an average detector.

§15.209 (d) The provisions in §§ 15.225, measuring emissions at distances other than the distances specified in the above table, determining the frequency range over which radiated emissions are to be measured, and limiting peak emissions apply to all devices operated under this part.

### **TEST PROCEDURE**

ANSI C63.10, 2013

The EUT is an intentional radiator that incorporates a digital device, the highest fundamental frequency generated or used in the device is 13.56 MHz; therefore, the frequency range was investigated from 0.15 MHz to the 10<sup>th</sup> harmonic of the highest fundamental frequency, or 1000 MHz, whichever is greater.

For below 30MHz testing, investigation was done on three antenna orientations (parallel, perpendicular, and ground-parallel), parallel and perpendicular are the worst orientations, therefore testing was performed on these two orientations only.

### **KDB 414788 Open Field Site(OFS) and Chamber Correlation Justification**

Base on FCC 15.31 (f) (2): measurements may be performed at a distance closer than that specified in the regulations; however, an attempt should be made to avoid making measurements in the near field.

OFS and chamber correlation testing had been performed and chamber measured test result is the worst case test result.

### **RESULTS**

### 8.1.1. FUNDAMENTAL EMISSION MASK (11.56 – 15.56MHz)

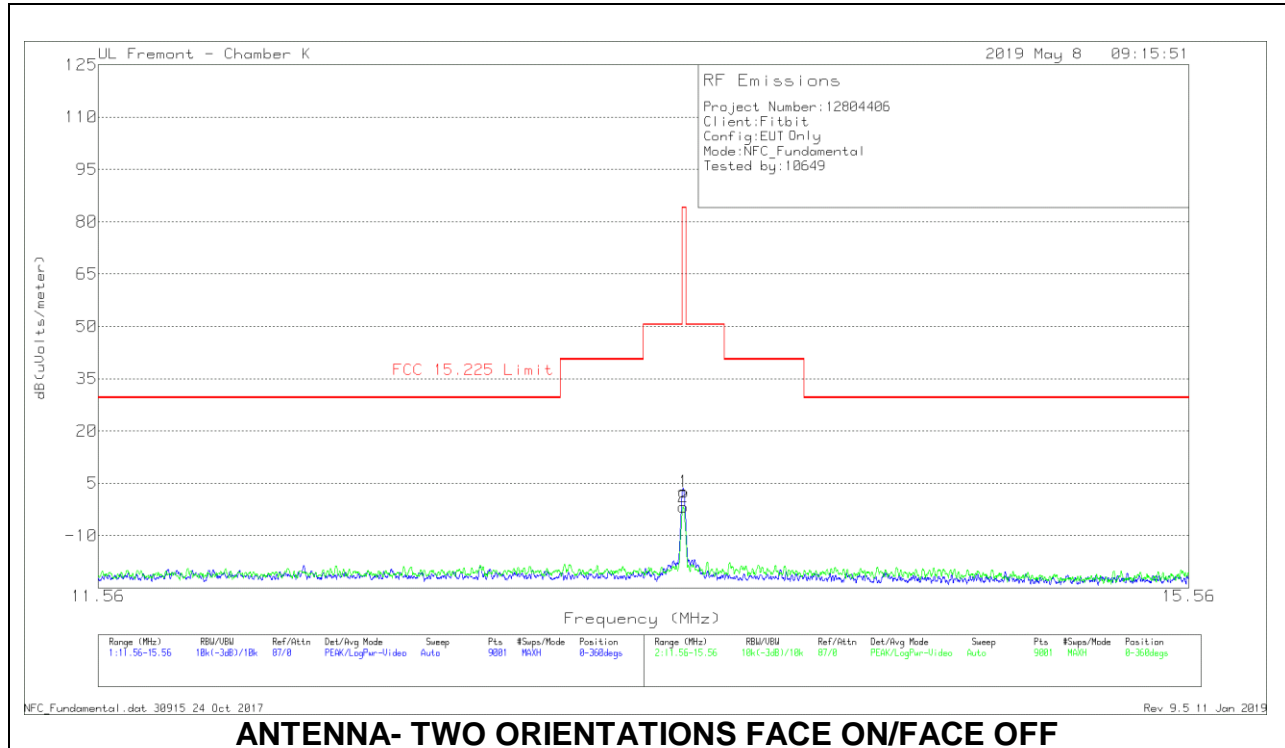

#### Data

Marker	Frequency (MHz)	Meter Reading (dBuV)	Det	Loop Antenna (ACF)	Cables (dB)	Dist Corr 30m (dB) 40Log	Corrected Reading dB(uVolts/meter)	FCC 15.225 Limit	PK Margin (dB)	Azimuth (Degs)
1	13.56066	39.65	Pk	34.3	-31.5	-40	2.45	84	-81.55	0-360
2	13.55711	35.39	Pk	34.3	-31.5	-40	-1.81	84	-85.81	0-360

Pk - Peak detector

### 8.1.2. TRANSMITTER (0.09 – 30MHz)

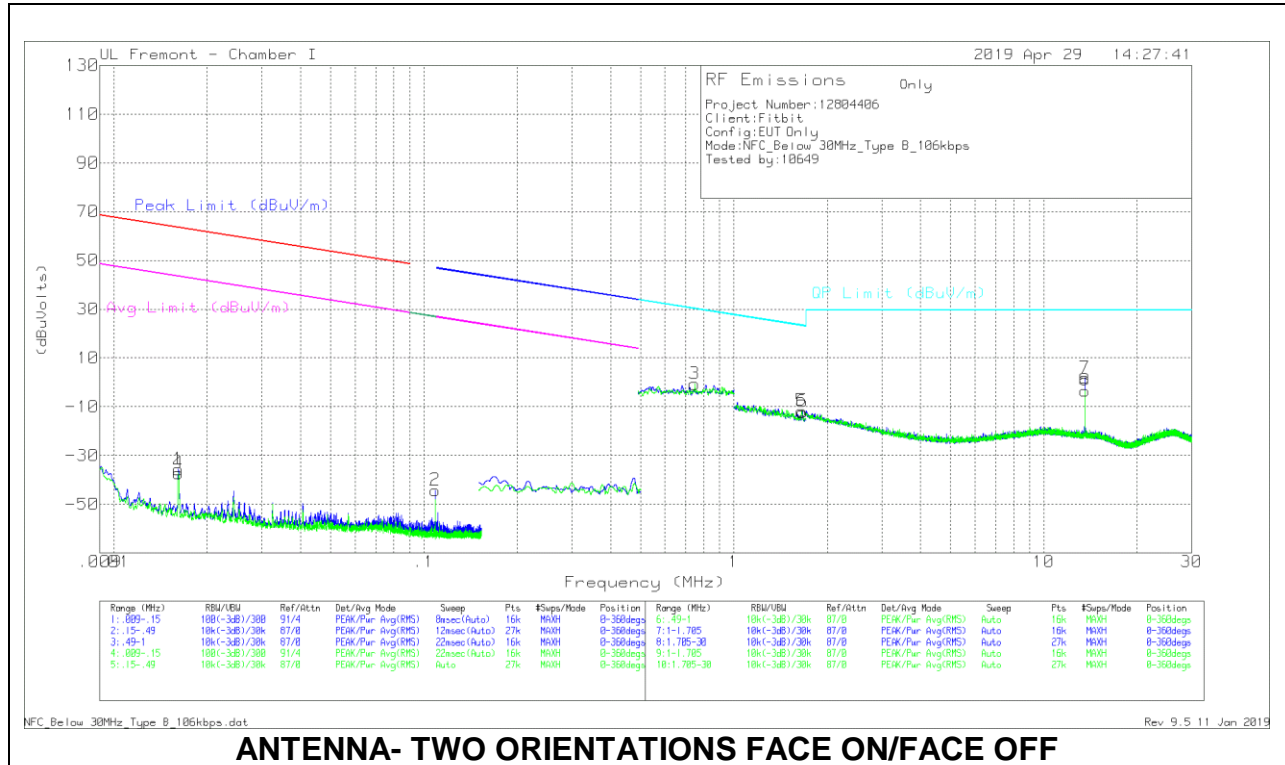

### ANTENNA- TWO ORIENTATIONS FACE ON/FACE OFF

#### Below 30MHz Data

Marker	Frequency (MHz)	Meter Reading (dBuV)	Det	Loop Antenna (ACF)	Cable (dB)	Dist Corr 300m	Corrected Reading (dBuVolts)	Peak Limit (dBuV/m)	Margin (dB)	Avg Limit (dBuV/m)	Margin (dB)	QP Limit (dBuV/m)	Margin (dB)	Azimuth (Degs)
1	.01615	17.27	Pk	59.5	-32.4	-80	-35.63	63.42	-99.05	43.42	-79.05	-	-	0-360
2	.10877	11.95	Pk	55.7	-31.9	-80	-44.25	-	-	-	-	26.9	-71.15	0-360
4	.01615	15.65	Pk	59.5	-32.4	-80	-37.25	63.42	-100.67	43.42	-80.67	-	-	0-360

Marker	Frequency (MHz)	Meter Reading (dBuV)	Det	Loop Antenna (ACF)	Cables w/ PRE0180175 (dB)	Dist Corr 30m (dB) 40Log	Corrected Reading (dBuVolts)	QP Limit (dBuV/m)	Margin (dB)	Azimuth (Degs)
3	.74648	14.83	Pk	56.3	-31.8	-40	-67	30.15	-30.82	0-360
6	1.66306	16.52	Pk	43	-31.7	-40	-12.18	23.22	-35.4	0-360
5	1.65573	17.03	Pk	43	-31.7	-40	-11.67	23.25	-34.92	0-360

Marker 7 and 8 are fundamental  
 Pk - Peak detector

### 8.1.3. TRANSMITTER (30 – 1000MHz) HARMONICS AND SPURIOUS EMISSIONS

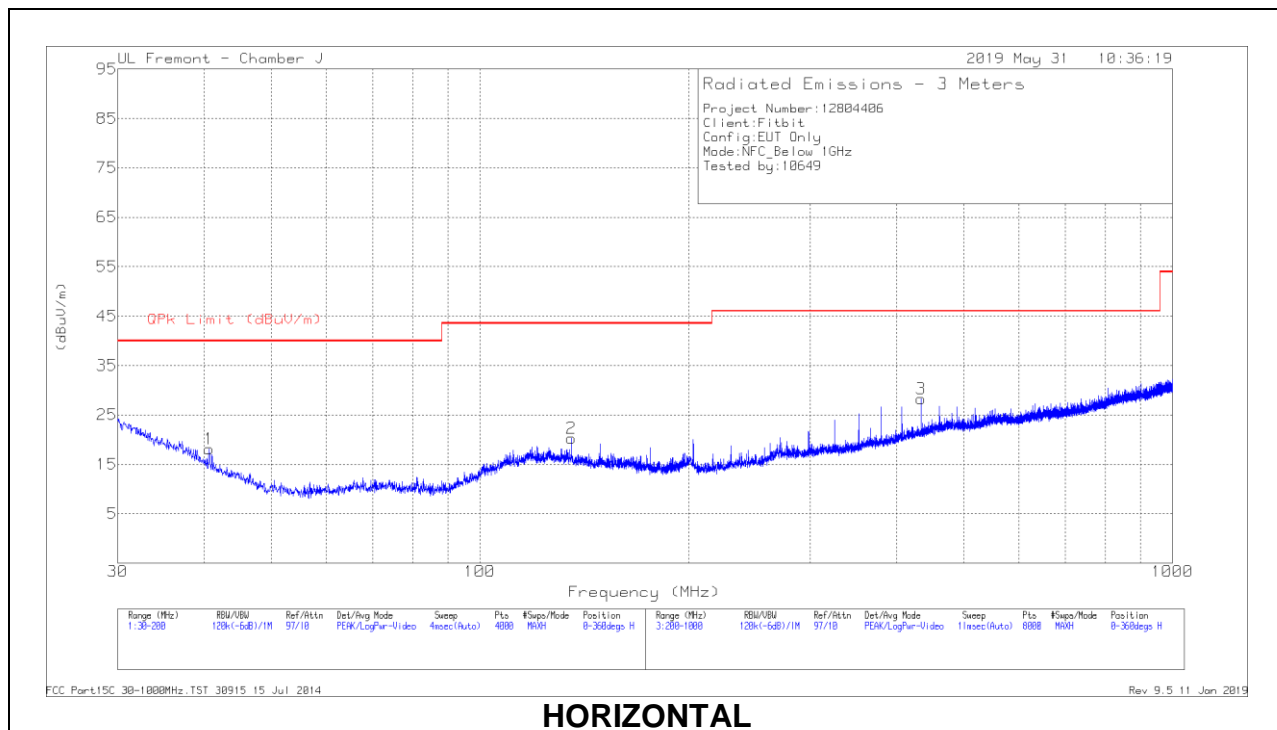

**HORIZONTAL**

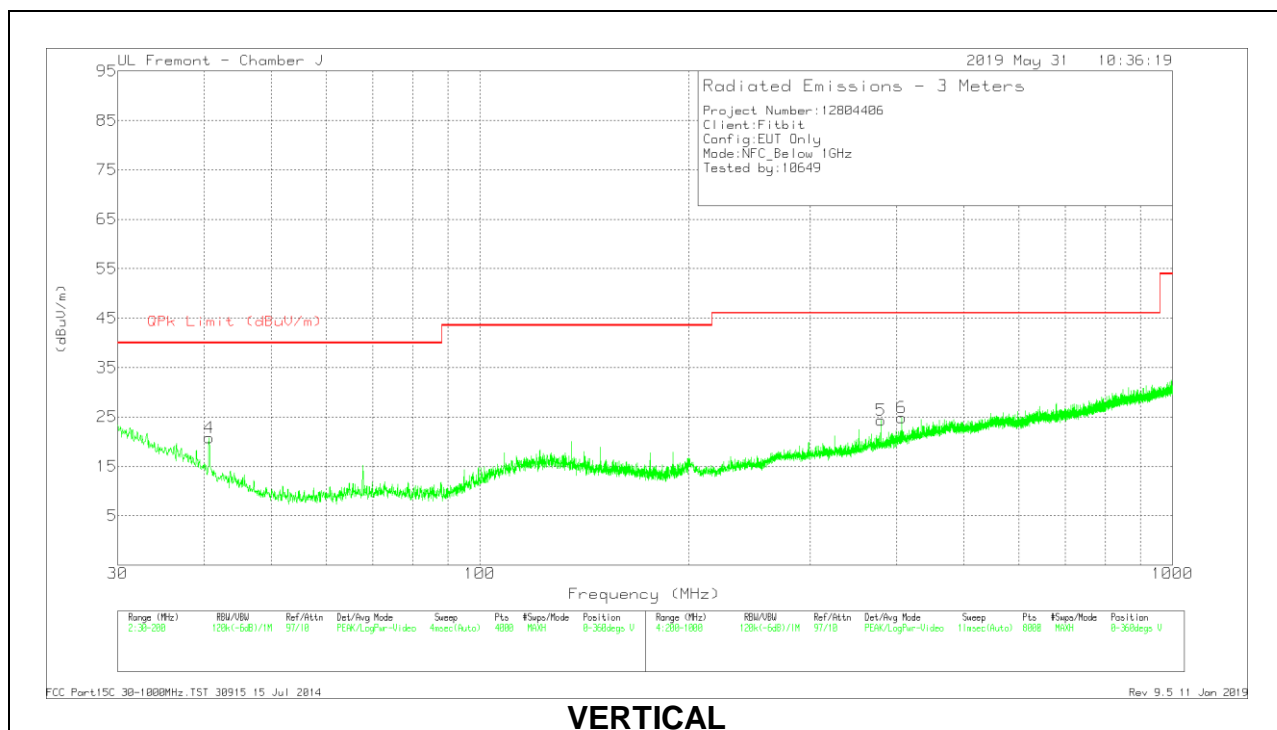

**VERTICAL**



**RADIATED EMISSIONS**

Marker	Frequency (MHz)	Meter Reading (dBuV)	Det	AF PRE0181575 (dB/m)	Amp Cbl (dB)	Corrected Reading (dBuV/m)	QPk Limit (dBuV/m)	Margin (dB)	Azimuth (Degs)	Height (cm)	Polarity
1	40.6278	30.62	Pk	19	-31.5	18.12	40	-21.88	0-360	198	H
2	* 135.5973	31.86	Pk	19.2	-30.8	20.26	43.52	-23.26	0-360	299	H
4	40.6703	33.43	Pk	18.9	-31.5	20.83	40	-19.17	0-360	101	V
3	433.8304	35.52	Pk	22.5	-29.7	28.32	46.02	-17.7	0-360	198	H
	433.9517	21.52	Qp	22.5	-29.7	14.32	46.02	-31.7	5	346	H
5	379.6233	33.27	Pk	20.9	-29.8	24.37	46.02	-21.65	0-360	198	V
6	* 406.7269	32.71	Pk	21.8	-29.7	24.81	46.02	-21.21	0-360	198	V

\* - indicates frequency in CFR47 Pt 15 / IC RSS-Restricted Band

Qp - Quasi-Peak detector

Pk - Peak detector

## 9. FREQUENCY STABILITY

### LIMIT

§15.225 (e) The frequency tolerance of the carrier signal shall be maintained within  $\pm 0.01\%$  of the operating frequency, over a temperature variation of -20 degrees to +50 degrees C at normal supply voltage, and for a variation in the primary supply voltage from 85% to 115% of the rated supply voltage at a temperature of 20 degrees C. For battery operated equipment, the equipment tests shall be performed using a new battery.

RSS-210 Annex B.6: Carrier frequency stability shall be maintained to  $\pm 0.01\%$  ( $\pm 100$  ppm).

### TEST PROCEDURE

ANSI C63.10, 2013 Clause 6.8.1 and 6.8.2

### RESULTS

No non-compliance noted.

<b>ID:</b>	20756 CW	<b>Date:</b>	05/11/2019
------------	----------	--------------	------------

### TYPE B 106Kbps

Reference Frequency: EUT Channel 13.56 MHz @ 20°C										
Limit: $\pm 100$ ppm = 1.356 kHz										
Power Supply	Envir. Temp	Frequency Deviation Measured with Time Elapse								
(Vdc)	(°C)	Startup (MHz)	Delta (ppm)	@ 2 mins (MHz)	Delta (ppm)	@ 5 mins (MHz)	Delta (ppm)	@ 10 mins (MHz)	Delta (ppm)	Limit (ppm)
4.40	50	13.5599463	1.371	13.5599475	1.282	13.5599489	1.177	13.5599514	0.993	$\pm 100$
4.40	40	13.5599488	1.184	13.5599478	1.259	13.5599473	1.293	13.5599474	1.288	$\pm 100$
4.40	30	13.5599485	1.210	13.5599501	1.093	13.5599526	0.906	13.5599544	0.775	$\pm 100$
4.40	<b>20</b>	<b>13.5599649</b>	<b>0.000</b>	<b>13.5599688</b>	<b>-0.289</b>	<b>13.5599705</b>	<b>-0.414</b>	<b>13.5599722</b>	<b>-0.539</b>	<b><math>\pm 100</math></b>
4.40	10	13.5599827	-1.315	13.5599868	-1.617	13.5599882	-1.721	13.5599894	-1.805	$\pm 100$
4.40	0	13.5599937	-2.124	13.5599938	-2.131	13.5599938	-2.135	13.5599941	-2.154	$\pm 100$
4.40	-10	13.5599806	-1.156	13.5599785	-1.005	13.5599766	-0.862	13.5599760	-0.822	$\pm 100$
3.74	20	13.5599752	-0.758	13.5599767	-0.872	13.5599777	-0.948	13.5599775	-0.932	$\pm 100$
5.06	20	13.5599730	-0.598	13.5599709	-0.447	13.5599710	-0.452	13.5599707	-0.428	$\pm 100$

\*\*EUT shuts down at temperature -20C, and no frequency error is reported at this temperature.