



CERTIFICATION TEST REPORT

Report Number. : 11981280-E1V1

Applicant : FITBIT INC.
199 FREMONT ST, 14TH FLOOR
SAN FRANCISCO,
CA 94105, U.S.A

Model : FB505

FCC ID : XRAFB505

IC : 8542A-FB505

EUT Description : SMART WATCH

Test Standard(s) : FCC 47 CFR PART 15 SUBPART C
INDUSTRY CANADA RSS - 247 ISSUE 2
INDUSTRY CANADA RSS-GEN ISSUE 4

Date Of Issue:

January 25, 2018

Prepared by:

UL Verification Services Inc.
47173 Benicia Street
Fremont, CA 94538, U.S.A.
TEL: (510) 771-1000
FAX: (510) 661-0888



Revision History

<u>Rev.</u>	<u>Issue Date</u>	<u>Revisions</u>	<u>Revised By</u>
V1	1/25/2018	Initial Issue	--

TABLE OF CONTENTS

1. ATTESTATION OF TEST RESULTS	5
2. TEST METHODOLOGY	7
3. FACILITIES AND ACCREDITATION	7
4. CALIBRATION AND UNCERTAINTY	8
4.1. <i>MEASURING INSTRUMENT CALIBRATION</i>	8
4.2. <i>SAMPLE CALCULATION</i>	8
4.3. <i>MEASUREMENT UNCERTAINTY</i>	8
5. EQUIPMENT UNDER TEST	9
5.1. <i>DESCRIPTION OF EUT</i>	9
5.2. <i>MAXIMUM OUTPUT POWER</i>	9
5.3. <i>DESCRIPTION OF AVAILABLE ANTENNAS</i>	9
5.4. <i>SOFTWARE AND FIRMWARE</i>	9
5.5. <i>WORST-CASE CONFIGURATION AND MODE</i>	10
5.6. <i>DESCRIPTION OF TEST SETUP</i>	11
6. TEST AND MEASUREMENT EQUIPMENT	14
7. MEASUREMENT METHODS	15
8. ANTENNA PORT TEST RESULTS	16
8.1. <i>ON TIME, DUTY CYCLE</i>	16
8.2. <i>BLE</i>	18
8.2.1. <i>6 dB BANDWIDTH</i>	18
8.2.2. <i>99% BANDWIDTH</i>	21
8.2.3. <i>AVERAGE POWER</i>	24
8.2.4. <i>OUTPUT POWER</i>	25
8.2.5. <i>POWER SPECTRAL DENSITY</i>	26
8.2.6. <i>CONDUCTED BANDEDGE AND SPURIOUS EMISSIONS</i>	29
9. RADIATED TEST RESULTS	33
9.1. <i>LIMITS AND PROCEDURE</i>	33
9.2. <i>TRANSMITTER ABOVE 1GHZ</i>	34
9.2.1. <i>RESTRICTED BANDEDGE (LOW CHANNEL)</i>	34
9.2.2. <i>AUTHORIZED BANDEDGE (HIGH CHANNEL)</i>	36
9.2.3. <i>HARMONICS AND SPURIOUS EMISSIONS</i>	38
9.3. <i>WORST-CASE BELOW 30MHz</i>	44
9.4. <i>WORST-CASE 30MHz TO 1GHz</i>	46

9.5. WORST-CASE ABOVE 18 GHz.....	48
10. AC POWER LINE CONDUCTED EMISSIONS	50
10.1.1. EUT POWERED BY AC/DC ADAPTER VIA USB CABLE	51
11. SETUP PHOTOS.....	53

1. ATTESTATION OF TEST RESULTS

COMPANY NAME: FITBIT INC.
199 FREMONT ST, 14TH FLOOR
SAN FRANCISCO,
CA 94105, U.S.A

EUT DESCRIPTION: SMART WATCH

MODEL: FB505

SERIAL NUMBER: B2-H1-213 (RADIATED)
B2-A1-1367P (CONDUCTED)

DATE TESTED: DECEMBER 22, 2017 – DECEMBER 29, 2017

APPLICABLE STANDARDS	
STANDARD	TEST RESULTS
CFR 47 Part 15 Subpart C	Complies
INDUSTRY CANADA RSS-247 Issue 2	Complies
INDUSTRY CANADA RSS-GEN Issue 4	Complies

UL Verification Services Inc. tested the above equipment in accordance with the requirements set forth in the above standards. All indications of Pass/Fail in this report are opinions expressed by UL Verification Services Inc. based on interpretations and/or observations of test results. Measurement Uncertainties were not taken into account and are published for informational purposes only. The test results show that the equipment tested is capable of demonstrating compliance with the requirements as documented in this report.

Note: The results documented in this report apply only to the tested sample, under the conditions and modes of operation as described herein. This document may not be altered or revised in any way unless done so by UL Verification Services Inc. and all revisions are duly noted in the revisions section. Any alteration of this document not carried out by UL Verification Services Inc. will constitute fraud and shall nullify the document. This report must not be used by the client to claim product certification, approval, or endorsement by NVLAP, NIST, any agency of the Federal Government, or any agency of U.S. government.

Approved & Released For
UL Verification Services Inc. By:



FRANCISCO DE ANDA
OPERATIONS LEAD
UL Verification Services Inc.

Prepared By:



ERIC YU
TEST ENGINEER
UL Verification Services Inc.

Reviewed By:



TINA CHU
SENIOR PROJECT ENGINEER
UL Verification Services Inc.

2. TEST METHODOLOGY

The tests documented in this report were performed in accordance with FCC CFR 47 Part 2, FCC CFR 47 Part 15, KDB 558074 D01 v04, ANSI C63.10-2013, RSS-GEN Issue 4, and RSS-247 Issue 2.

3. FACILITIES AND ACCREDITATION

The test sites and measurement facilities used to collect data are located at 47173 and 47266 Benicia Street, Fremont, California, USA. Line conducted emissions are measured only at the 47173 address. The following table identifies which facilities were utilized for radiated emission measurements documented in this report. Specific facilities are also identified in the test results sections.

47173 Benicia Street	47266 Benicia Street
<input checked="" type="checkbox"/> Chamber A (IC:2324B-1)	<input type="checkbox"/> Chamber D (IC:22541-1)
<input type="checkbox"/> Chamber B (IC:2324B-2)	<input type="checkbox"/> Chamber E (IC:22541-2)
<input type="checkbox"/> Chamber C (IC:2324B-3)	<input type="checkbox"/> Chamber F (IC:22541-3)
	<input type="checkbox"/> Chamber G (IC:22541-4)
	<input type="checkbox"/> Chamber H (IC:22541-5)

The above test sites and facilities are covered under FCC Test Firm Registration # 208313.

UL Verification Services Inc. is accredited by NVLAP, Laboratory Code 200065-0. The full scope of accreditation can be viewed at <http://ts.nist.gov/standards/scopes/2000650.htm>.

4. CALIBRATION AND UNCERTAINTY

4.1. MEASURING INSTRUMENT CALIBRATION

The measuring equipment utilized to perform the tests documented in this report has been calibrated in accordance with the manufacturer's recommendations, and is traceable to recognized national standards.

4.2. SAMPLE CALCULATION

Where relevant, the following sample calculation is provided:

$$\begin{aligned} \text{Field Strength (dBuV/m)} &= \text{Measured Voltage (dBuV)} + \text{Antenna Factor (dB/m)} + \\ &\text{Cable Loss (dB)} - \text{Preamp Gain (dB)} \\ 36.5 \text{ dBuV} + 18.7 \text{ dB/m} + 0.6 \text{ dB} - 26.9 \text{ dB} &= 28.9 \text{ dBuV/m} \end{aligned}$$

4.3. MEASUREMENT UNCERTAINTY

Where relevant, the following measurement uncertainty levels have been estimated for tests performed on the apparatus:

Parameter	Uncertainty
Conducted Disturbance, 9KHz to 0.15 MHz	3.84 dB
Conducted Disturbance, 0.15 to 30 MHz	3.65 dB
Radiated Disturbance, 9KHz to 30 MHz	3.15 dB
Radiated Disturbance, 30 to 1000 MHz	5.36 dB
Radiated Disturbance, 1000 to 18000 MHz	4.32 dB
Radiated Disturbance, 18000 to 26000 MHz	4.45 dB
Radiated Disturbance, 26000 to 40000 MHz	5.24 dB
Occupied Channel Bandwidth	±0.39 %

Uncertainty figures are valid to a confidence level of 95%.

5. EQUIPMENT UNDER TEST

5.1. DESCRIPTION OF EUT

The equipment under test is a Smart Watch.

5.2. MAXIMUM OUTPUT POWER

The transmitter has a maximum peak conducted output power as follows:

Frequency Range (MHz)	Mode	Output Power (dBm)	Output Power (mW)
2402 - 2480	BLE	7.92	6.19

5.3. DESCRIPTION OF AVAILABLE ANTENNAS

Frequency Band (GHz)	Antenna Peak Gain (dBi)
2.4	-11.30

5.4. SOFTWARE AND FIRMWARE

The test utility software used during testing was Tera Term Ver 4.93.
The firmware installed in the EUT during testing was Version 32.3.125.8.

5.5. WORST-CASE CONFIGURATION AND MODE

EUT has 1 type of plastic wristband and 3 types of metallic bands: Mesh, Link and Tri-Link. The worst-case configuration was investigated with wristbands with and without a charger and it was determined that EUT with plastic wristband and with a charger was the worst-case; therefore, all final radiated testing was performed with this configuration.

Radiated bandedge, harmonics, and spurious emissions from 1 GHz to 18GHz were performed with EUT set to transmit at the Low/Middle/High channels.

Radiated emission below 1GHz, above 18GHz, and power line conducted emission were performed with the EUT set to transmit at the channel with highest output power as worst-case scenario.

The fundamental of the EUT was investigated in three orthogonal orientations X/Y/Z, it was determined that Z-Portrait orientation was worst-case orientation. Therefore, all final radiated testing was performed with the EUT in Z-Portrait orientation.

Worst-case data rate as provided by the client was:

BLE: 1 Mbps.

BLE and Wifi bands do not transmit simultaneously.

5.6. DESCRIPTION OF TEST SETUP

SUPPORT EQUIPMENT

Support Equipment List				
Description	Manufacturer	Model	Serial Number	FCC ID
Laptop AC/DC Adapter	Lenovo	ADLX45DLCC2A	11S36200283ZZ10051KU2U	NA
Laptop	Lenovo	ThinkPad X1 Carbon	R9-0G4NPM 15/06	NA
AC/DC Adapter	Homespot	S005AYU0500100	N/A	NA

I/O CABLES (CONDUCTED TEST)

I/O Cable List						
Cable No	Port	# of identical ports	Connector Type	Cable Type	Cable Length (m)	Remarks
1	AC	1	AC	Unshielded	1	AC Mains to AC/DC Adapter
2	DC	1	DC	Unshielded	1.5	AC/DC Adapter to Laptop
3	USB	1	USB	Unshielded	1	Laptop to EUT
4	Antenna	1	SMA	Unshielded	0.2	To spectrum analyzer

I/O CABLES (AC POWER CONDUCTED TEST AND RADIATED TEST)

I/O Cable List						
Cable No	Port	# of identical ports	Connector Type	Cable Type	Cable Length (m)	Remarks
1	USB	1	USB	Unshielded	1	Charger to AC/DC adapter

TEST SETUP-CONDUCTED TEST

The EUT was placed in charger and powered by host laptop. Test software exercised the EUT.

SETUP DIAGRAM

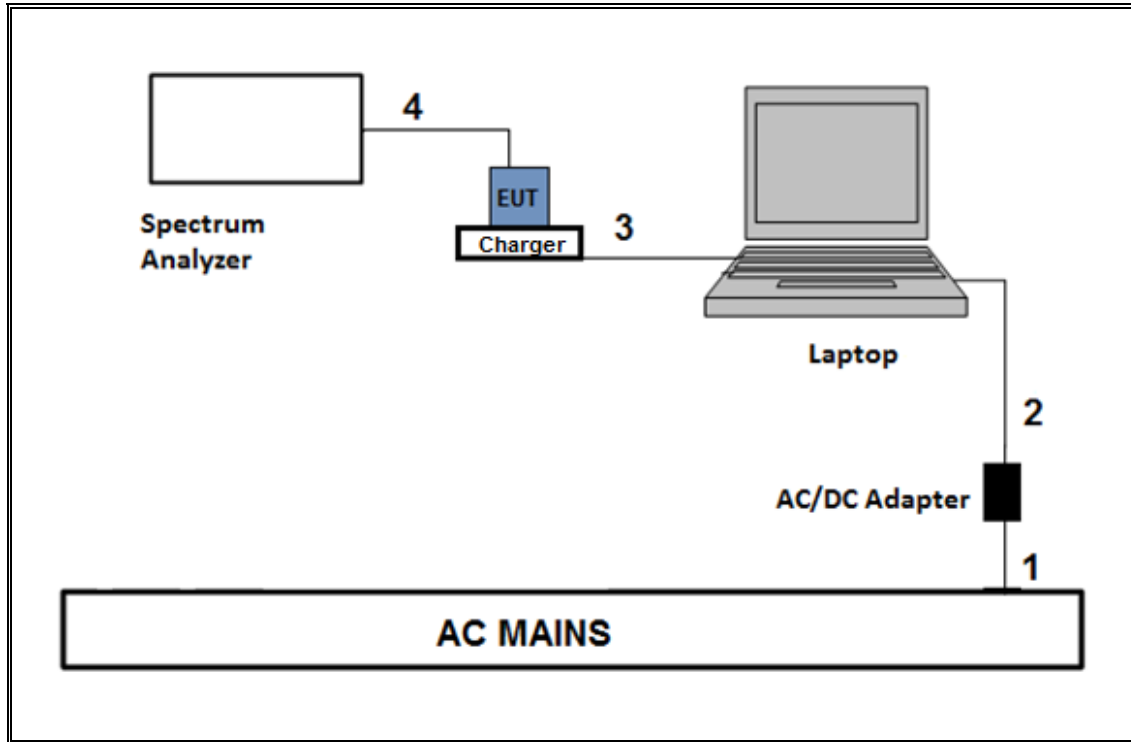

TEST SETUP- AC LINE CONDUCTED TEST AND RADIATED TEST

The EUT was placed in charger and powered by an AC/DC adapter. Test software exercised the EUT.

SETUP DIAGRAM

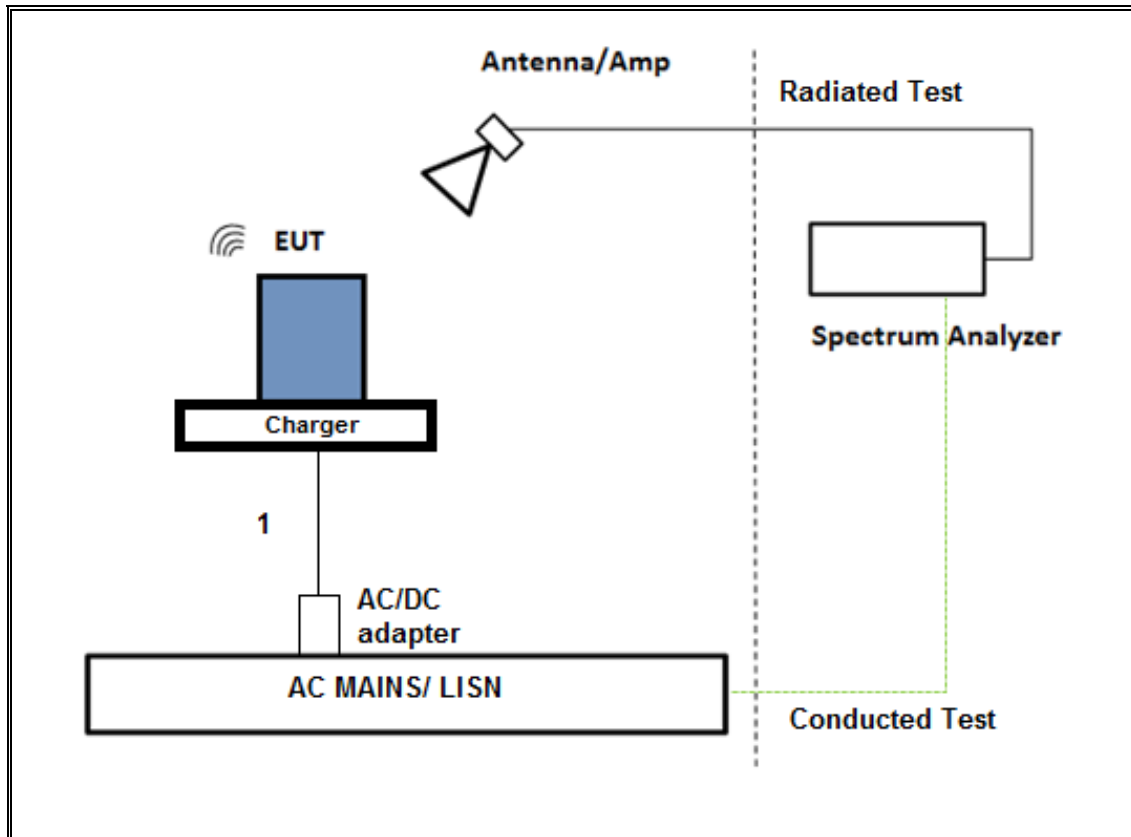

6. TEST AND MEASUREMENT EQUIPMENT

The following test and measurement equipment was utilized for the tests documented in this report:

TEST EQUIPMENT LIST				
Description	Manufacturer	Model	Asset	Cal Due
Antenna, Horn 1-18GHz	ETS Lindgren	3117	T862	06/09/2018
Amplifier, 1 to 18GHz	Miteq	AFS42-00101800-25-S-42	T1165	11/25/2018
Antenna, Active Loop 9KHz to 30MHz	EMCO	6502	T35	3/09/2018
Amplifier, 10KHz to 1GHz, 32dB	SONOMA INSTRUMENT	310N	T300	12/11/2018
Spectrum Analyzer, PXA 3Hz to 44GHz	Keysight	N9030A	T1466	04/11/2018
Antenna, Broadband Hybrid, 30MHz to 2000MHz	Sunol Sciences	JB1	T130	10/16/2018
Amplifier, 30kHz-1000MHz	Keysight	8447D	T15	08/14/2018
Spectrum Analyzer, PXA, 3Hz to 44GHz	Keysight	N9030A	T905	1/11/2018
Spectrum Analyzer, PSA, 3Hz to 44GHz	Keysight	E4446A	T146	07/18/2018
Antenna Horn, 18 to 26GHz	ARA	MWH-1826	T89	01/04/2018
Amplifier, 1 to 26.5GHz 23.5dB gain Minimum	Keysight	8449B	T404	07/23/2018
Spectrum Analyzer, PXA, 3Hz to 44GHz	Keysight	N9030A-544	T1113	12/21/2018
Power Meter, P-series single channel	Keysight	N1912A	T1245	05/12/2018
Power Sensor	Keysight	N1921A	T413	06/22/2018
AC Line Conducted				
EMI Test Receiver 9KHz-7GHz	Rohde & Schwarz	ESCI7	T1124	11/07/2018
LISN for Conducted Emissions CISPR-16	Fischer	50/250-25-2-01	T1310	06/15/2018
Power Cable, Line Conducted Emissions	UL	PG1	T861	08/31/2018
UL AUTOMATION SOFTWARE				
Radiated Software	UL	UL EMC	Ver 9.5, Dec 01, 2016	
Conducted Software	UL	UL EMC	Ver 7.7, Dec 14, 2017	
AC Line Conducted Software	UL	UL EMC	Ver 9.5, May 26, 2015	

NOTES:

1. Equipment listed above that calibrated during the testing period was set for test after the calibration.
2. Equipment listed above that has a calibration due date during the testing period, the testing is completed before equipment expiration date.

7. MEASUREMENT METHODS

On Time and Duty Cycle: KDB 558074 D01 v04, Section 6.

6 dB BW: KDB 558074 D01 v04, Section 8.1.

Occupied BW (99%): ANSI C63.10-2013 Section 6.9.3

Output Power: KDB 558074 D01 v04, Section 9.1.3.

Power Spectral Density: KDB 558074 D01 v04, Section 10.2.

Out-of-band emissions in non-restricted bands: KDB 558074 D01 v04, Section 11.0.

Out-of-band emissions in restricted bands: KDB 558074 D01 v04, Section 12.1.

Band-edge: KDB 558074 D01 v04, Section 12.1.

AC Power-line conducted emissions: ANSI C63.10-2013, Section 6.2.

8. ANTENNA PORT TEST RESULTS

8.1. ON TIME, DUTY CYCLE

LIMITS

None; for reporting purposes only.

PROCEDURE

KDB 558074 Zero-Span Spectrum Analyzer Method.

ON TIME AND DUTY CYCLE RESULTS

Mode	ON Time B (msec)	Period (msec)	Duty Cycle x (linear)	Duty Cycle (%)	Duty Cycle Correction Factor (dB)	1/B Minimum VBW (kHz)
BLE	0.389	0.625	0.622	62.24%	2.06	2.571

DUTY CYCLE PLOTS

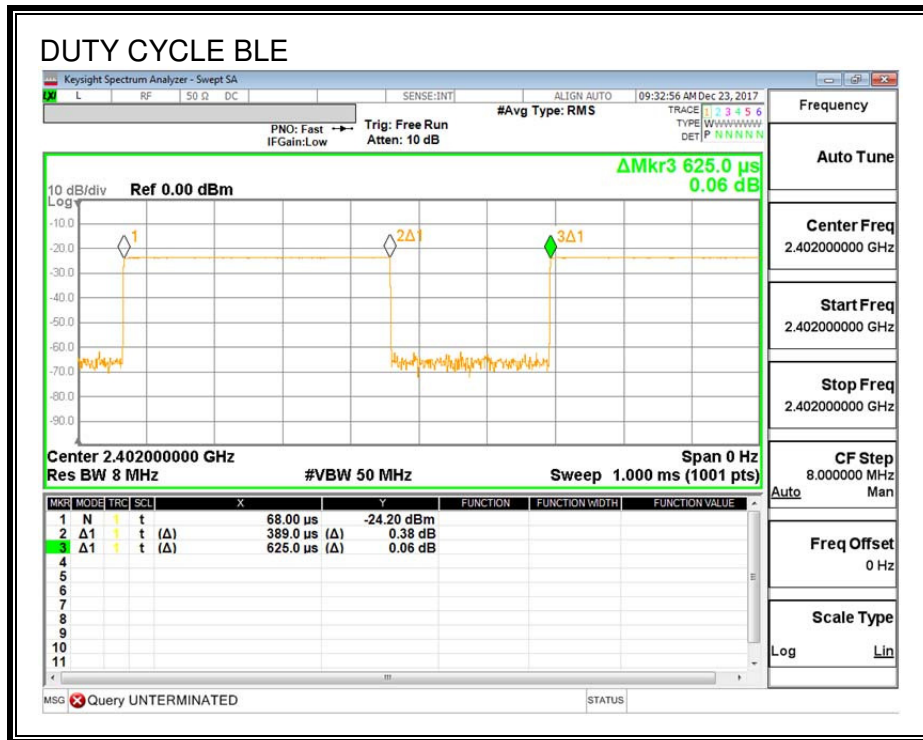

8.2. BLE

8.2.1. 6 dB BANDWIDTH

LIMITS

FCC §15.247 (a) (2)

IC RSS-247 (5.2) (a)

The minimum 6 dB bandwidth shall be at least 500 kHz.

RESULTS

Channel	Frequency (MHz)	6 dB Bandwidth (MHz)	Minimum Limit (MHz)
Low	2402	0.6920	0.5
Middle	2440	0.6960	0.5
High	2480	0.6980	0.5

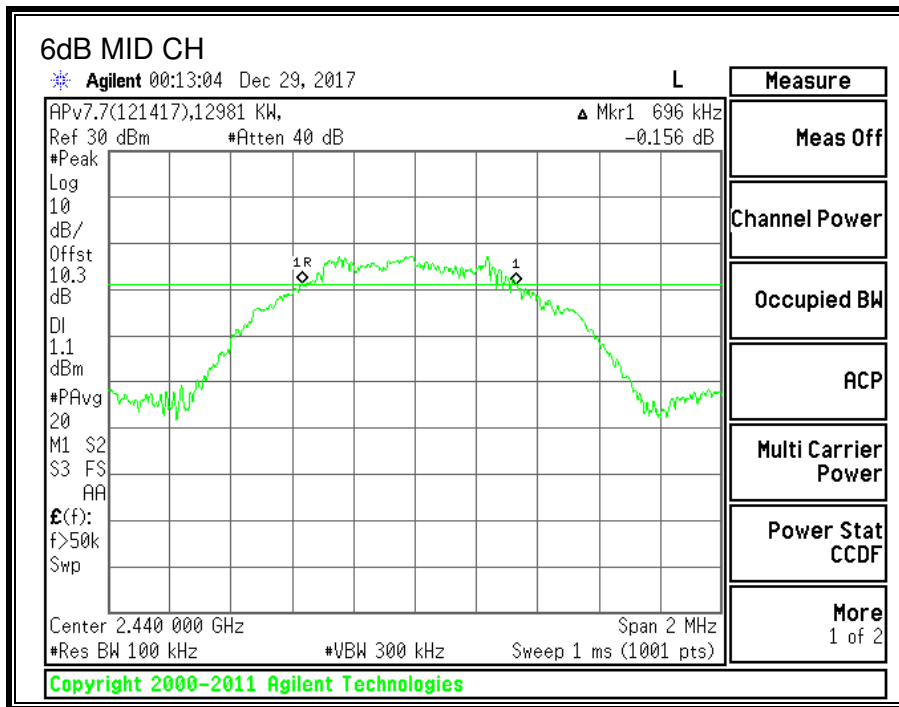
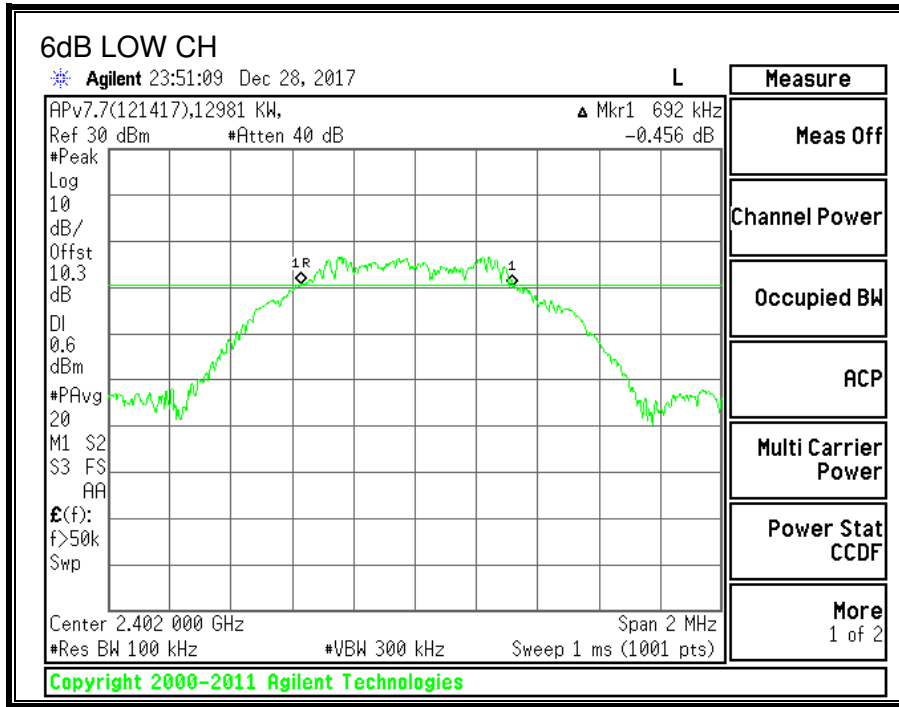

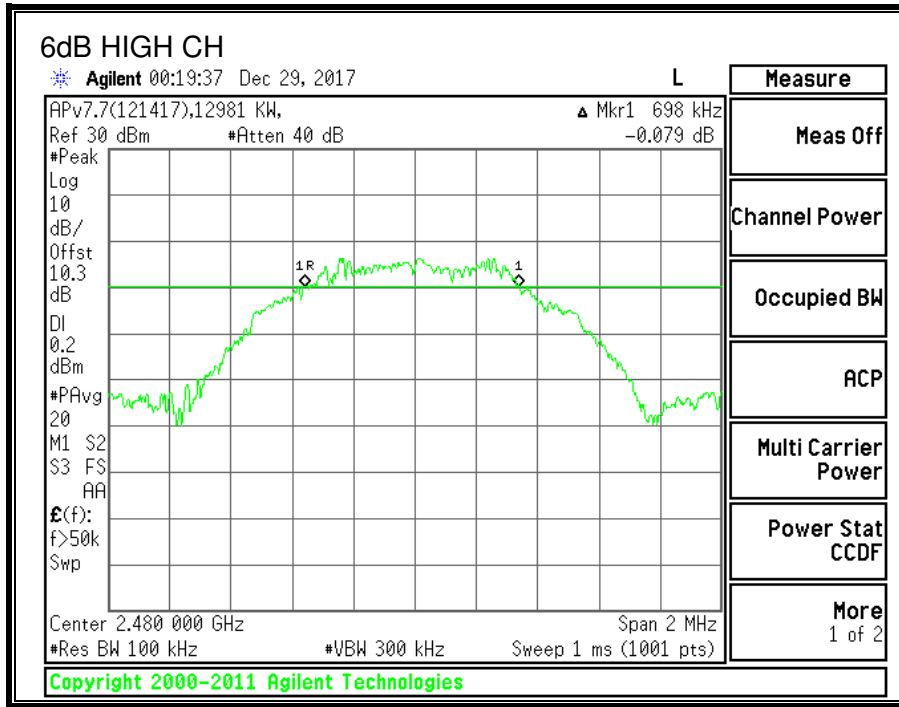

8.2.2. 99% BANDWIDTH

LIMITS

None; for reporting purposes only.

RESULTS

Channel	Frequency (MHz)	99% Bandwidth (MHz)
Low	2402	1.0529
Middle	2440	1.0540
High	2480	1.0533

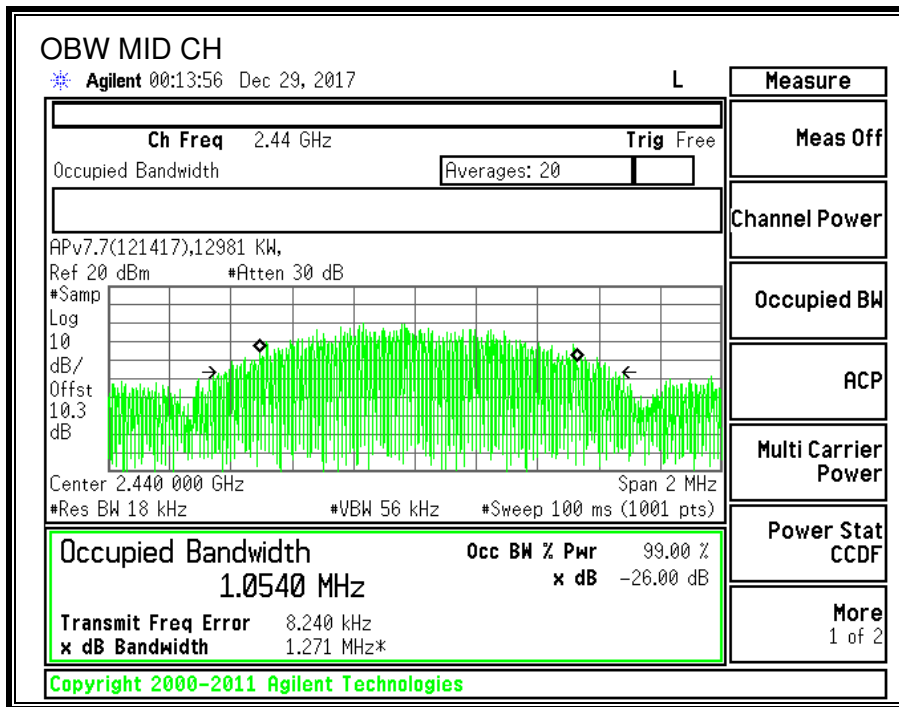
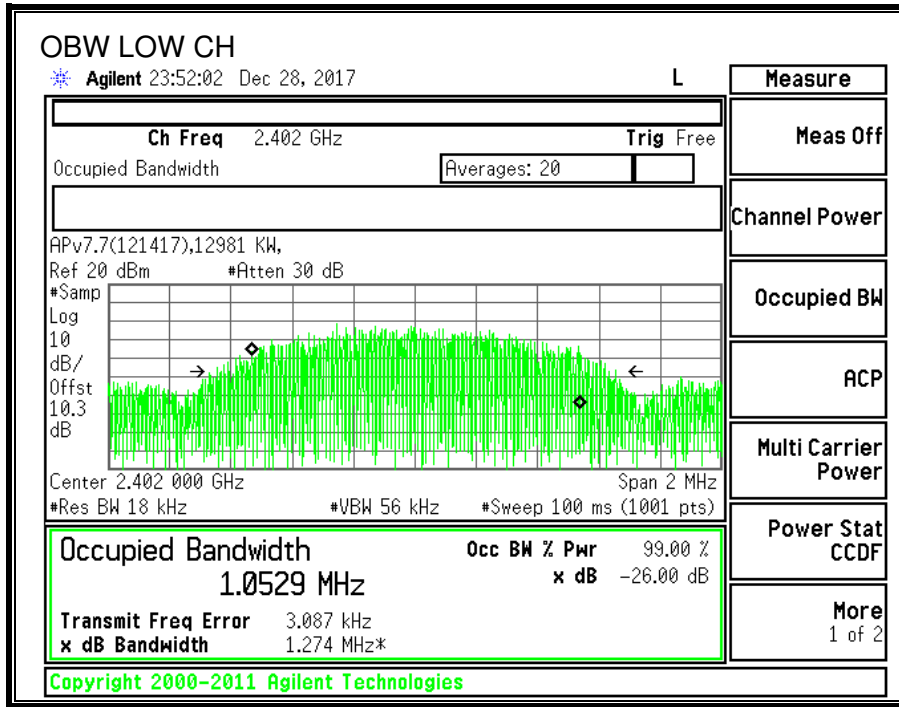

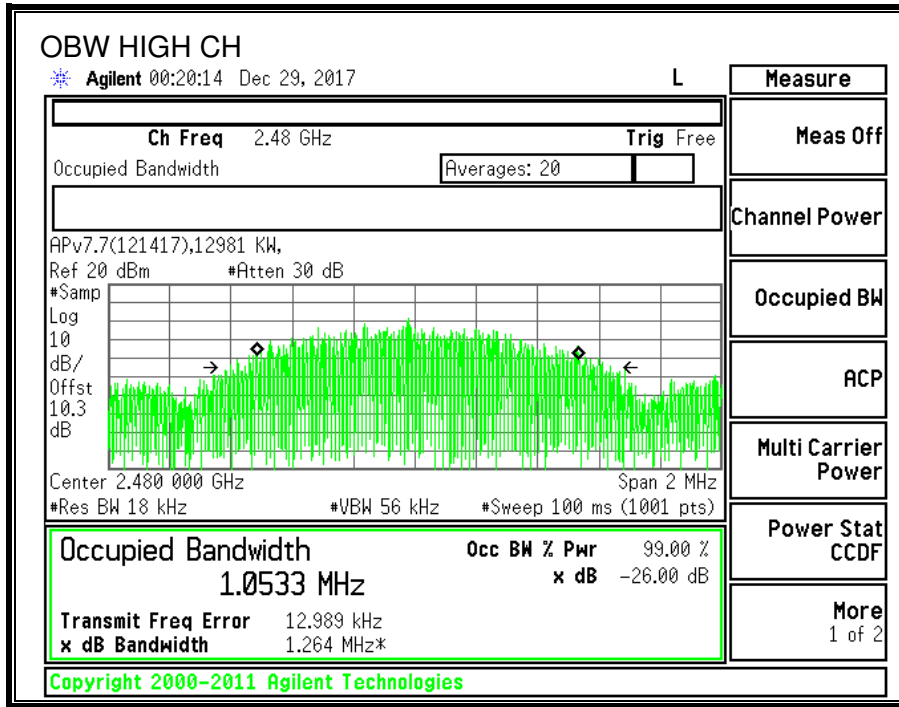

8.2.3. AVERAGE POWER

LIMITS

None; for reporting purposes only.

The cable assembly insertion loss of 10.3 dB (including 10 dB pad and 0.3 dB cable) was entered as an offset in the power meter to allow for direct reading of power.

RESULTS

ID:	12981	Date:	12/28/2017
------------	-------	--------------	------------

Channel	Frequency (MHz)	AV power (dBm)
Low	2402	7.62
Middle	2440	7.73
High	2480	6.93

8.2.4. OUTPUT POWER

LIMITS

FCC §15.247 (b)

IC RSS-247 (5.4) (d)

The maximum antenna gain is less than or equal to 6 dBi, therefore the limit is 30 dBm.

RESULTS

ID:	12981	Date:	12/28/2017
------------	-------	--------------	------------

Channel	Frequency (MHz)	Peak Power Reading (dBm)	Limit (dBm)	Margin (dB)
Low	2402	7.82	30	-22.18
Middle	2440	7.92	30	-22.08
High	2480	7.12	30	-22.88

8.2.5. POWER SPECTRAL DENSITY

LIMITS

FCC §15.247 (e)

IC RSS-247 (5.2) (b)

The power spectral density conducted from the transmitter to the antenna shall not be greater than 8 dBm in any 3 kHz band during any time interval of continuous transmission.

RESULTS

Channel	Frequency (MHz)	PSD (dBm)	Limit (dBm)	Margin (dB)
Low	2402	-6.52	8	-14.52
Middle	2440	-5.93	8	-13.93
High	2480	-6.79	8	-14.79

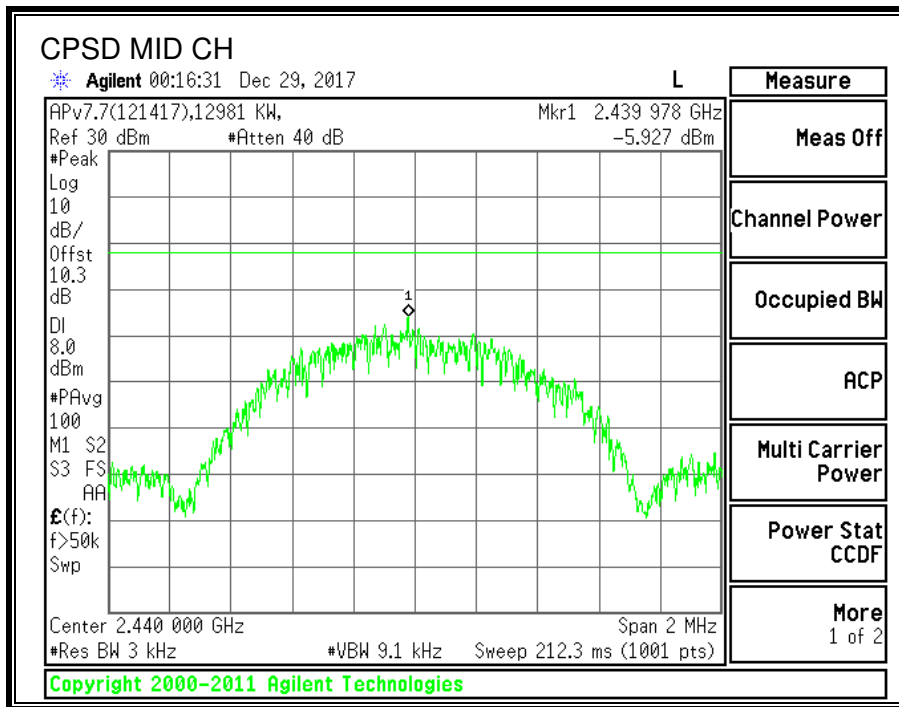
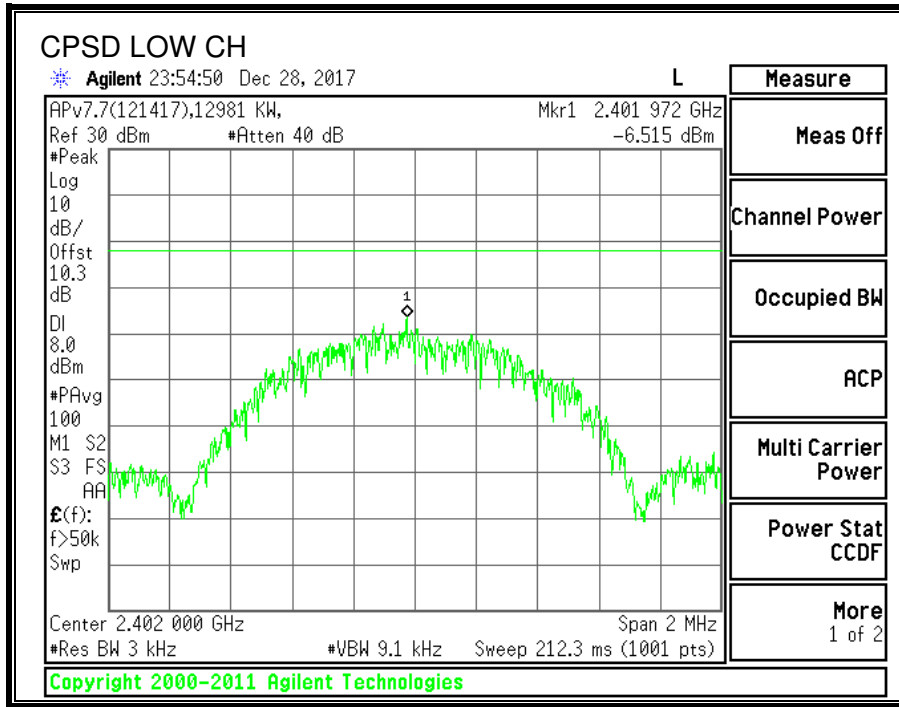

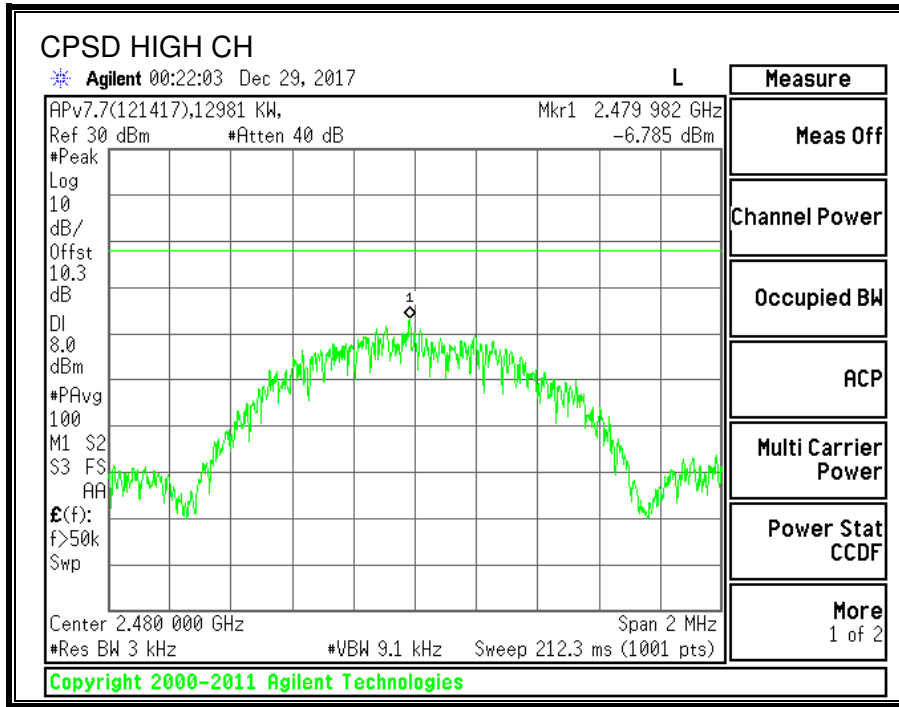

8.2.6. CONDUCTED BANEDGE AND SPURIOUS EMISSIONS

LIMITS

FCC §15.247 (d)

IC RSS-247 (5.5)

Output power was measured based on the use of a peak measurement, therefore the required attenuation is 20 dB.

RESULTS

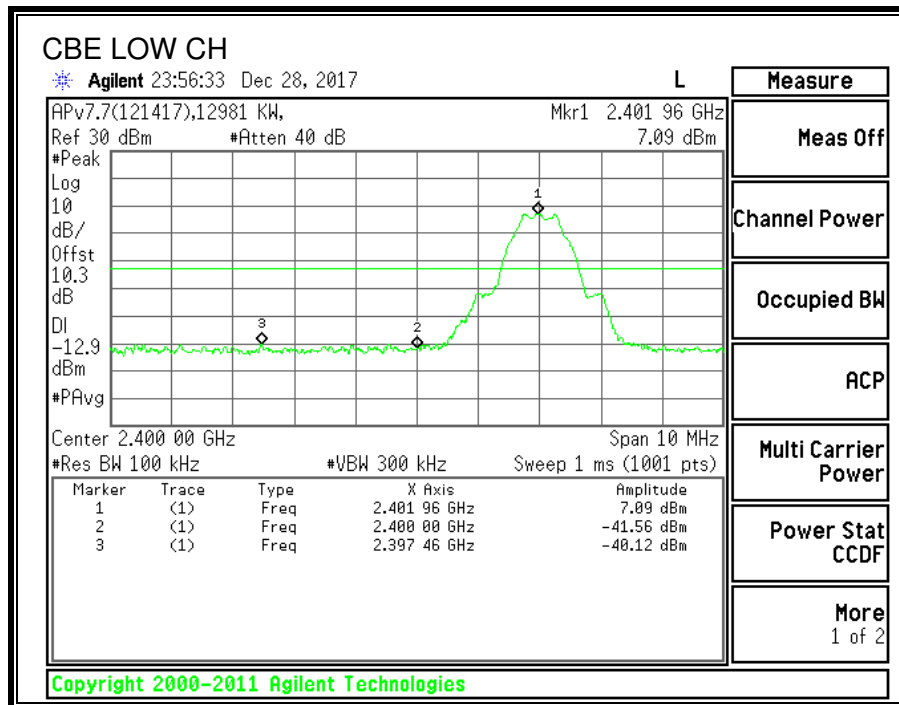

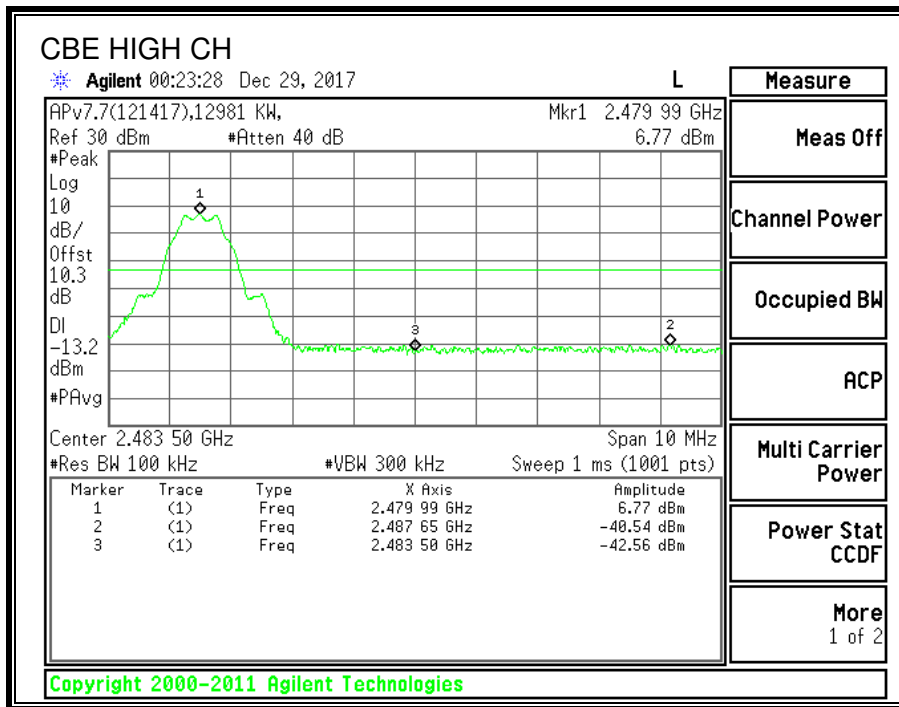
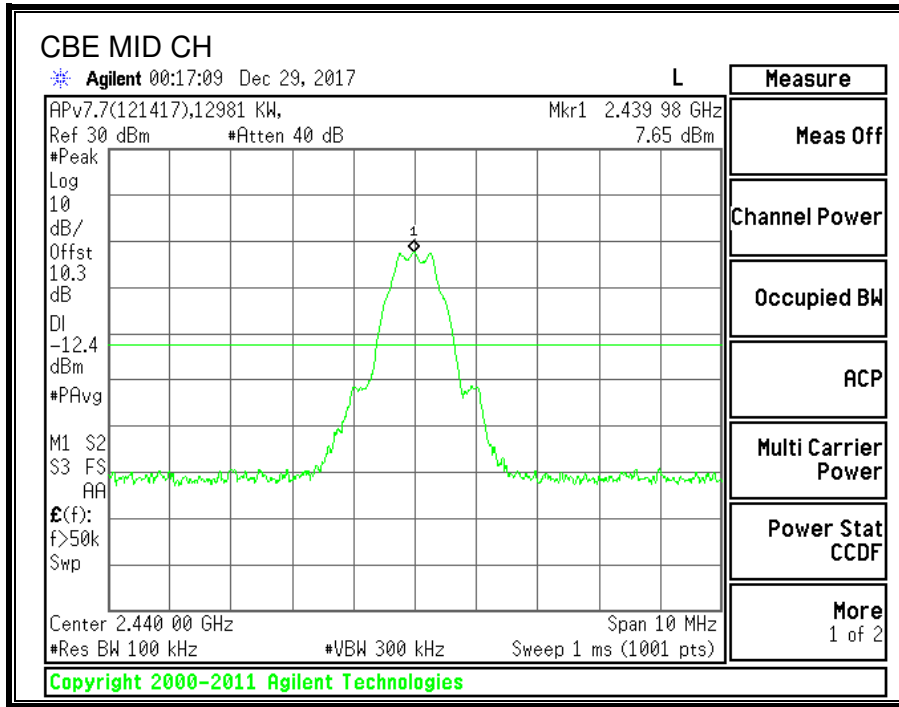

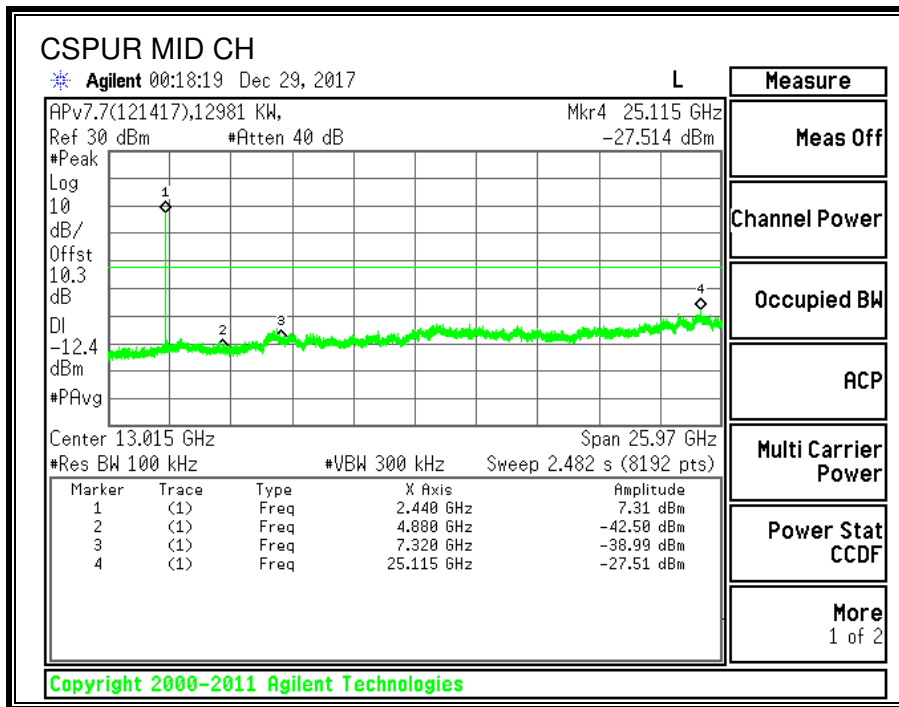
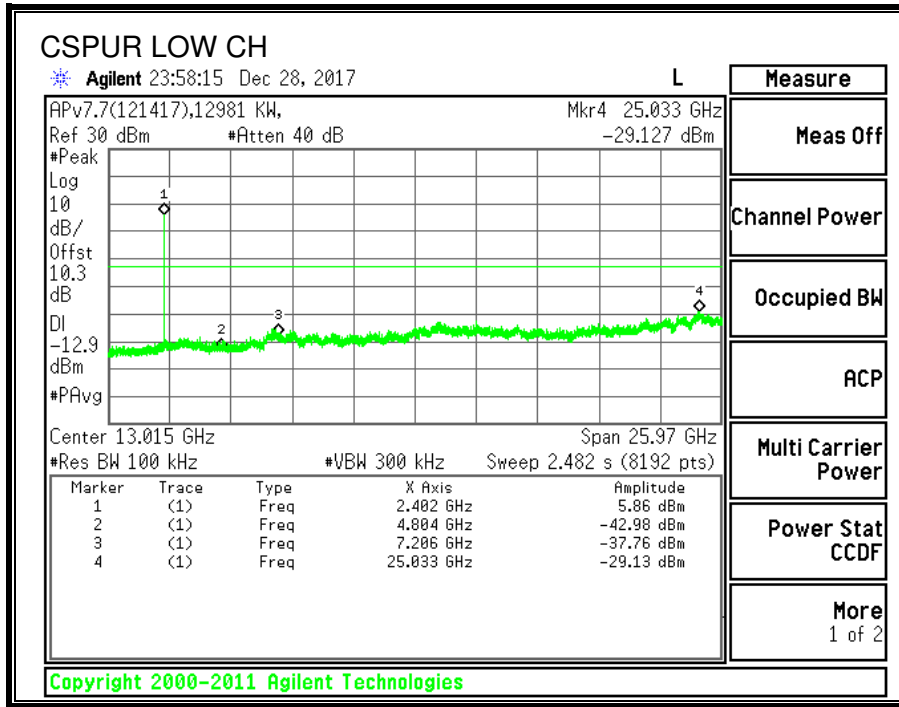

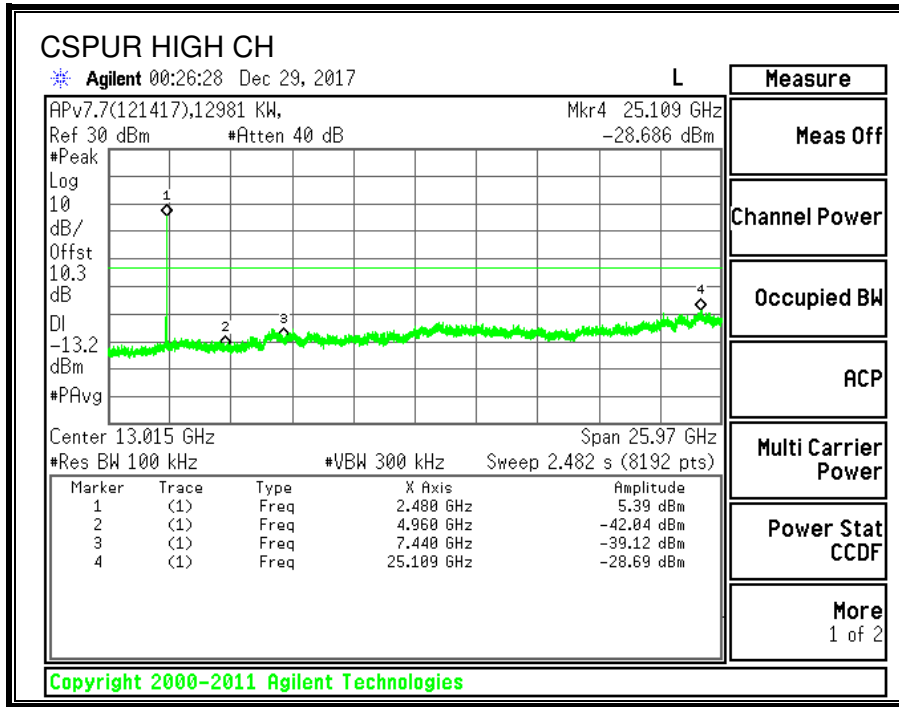

9. RADIATED TEST RESULTS

9.1. LIMITS AND PROCEDURE

LIMITS

FCC §15.205 and §15.209

IC RSS-GEN, Section 8.9 and 8.10

Frequency Range (MHz)	Field Strength Limit (uV/m) at 3 m	Field Strength Limit (dBuV/m) at 3 m
30 - 88	100	40
88 - 216	150	43.5
216 - 960	200	46
Above 960	500	54

TEST PROCEDURE

The EUT is placed on a non-conducting table 80 cm above the ground plane for measurement below 1GHz; 1.5 m above the ground plane for measurement above 1GHz. The antenna to EUT distance is 3 meters. The EUT is configured in accordance with ANSI C63.10. The EUT is set to transmit in a continuous mode.

For measurements below 1 GHz the resolution bandwidth is set to 100 kHz for peak detection measurements or 120 kHz for quasi-peak detection measurements. Peak detection is used unless otherwise noted as quasi-peak.

For pre-scans above 1 GHz the resolution bandwidth is set to 1 MHz; the video bandwidth is set to 30 KHz for peak measurements.

For final measurements above 1 GHz the resolution bandwidth is set to 1 MHz; the video bandwidth is set to 3 MHz for peak measurements and as applicable for average measurements.

The frequency range of interest is monitored at a fixed antenna height and EUT azimuth. The EUT is rotated through 360 degrees to maximize emissions received. The antenna is scanned from 1 to 4 meters above the ground plane to further maximize the emission. Measurements are made with the antenna polarized in both the vertical and the horizontal positions.

9.2. TRANSMITTER ABOVE 1GHZ

9.2.1. RESTRICTED BANDEGE (LOW CHANNEL)

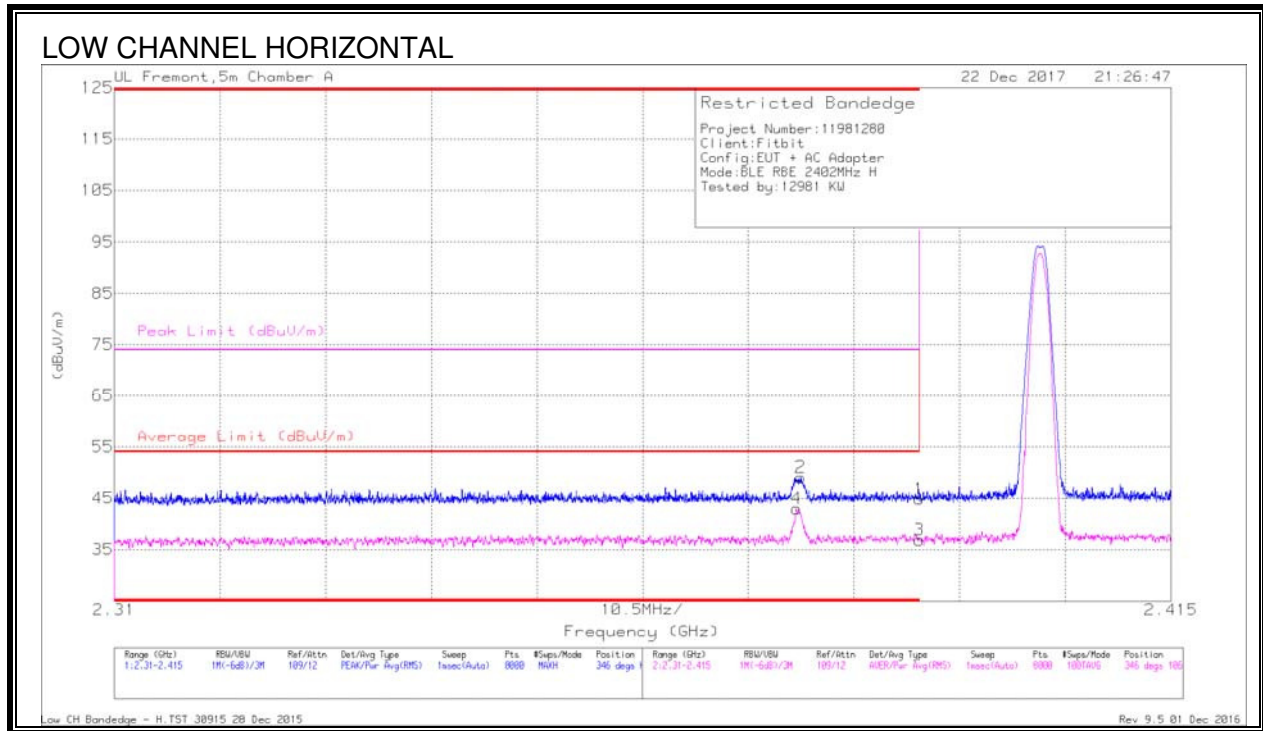

DATA

Marker	Frequency (GHz)	Meter Reading (dBuV)	Det	AF T862 (dB/m)	Amp/Cbl/Filtr/Pad (dB)	DC Corr (dB)	Corrected Reading (dBuV/m)	Average Limit (dBuV/m)	Margin (dB)	Peak Limit (dBuV/m)	PK Margin (dB)	Azimuth (Degs)	Height (cm)	Polarity
1	* 2.39	36.34	Pk	31.8	-23.3	0	44.84	-	-	74	-29.16	346	106	H
2	* 2.378	40.72	Pk	31.7	-23.4	0	49.02	-	-	74	-24.98	346	106	H
3	* 2.39	26.28	RMS	31.8	-23.3	2.06	36.84	54	-17.16	-	-	346	106	H
4	* 2.378	32.58	RMS	31.7	-23.4	2.06	42.94	54	-11.06	-	-	346	106	H

* - indicates frequency in CFR47 Pt 15 / IC RSS-Restricted Band

Pk - Peak detector

RMS - RMS detection

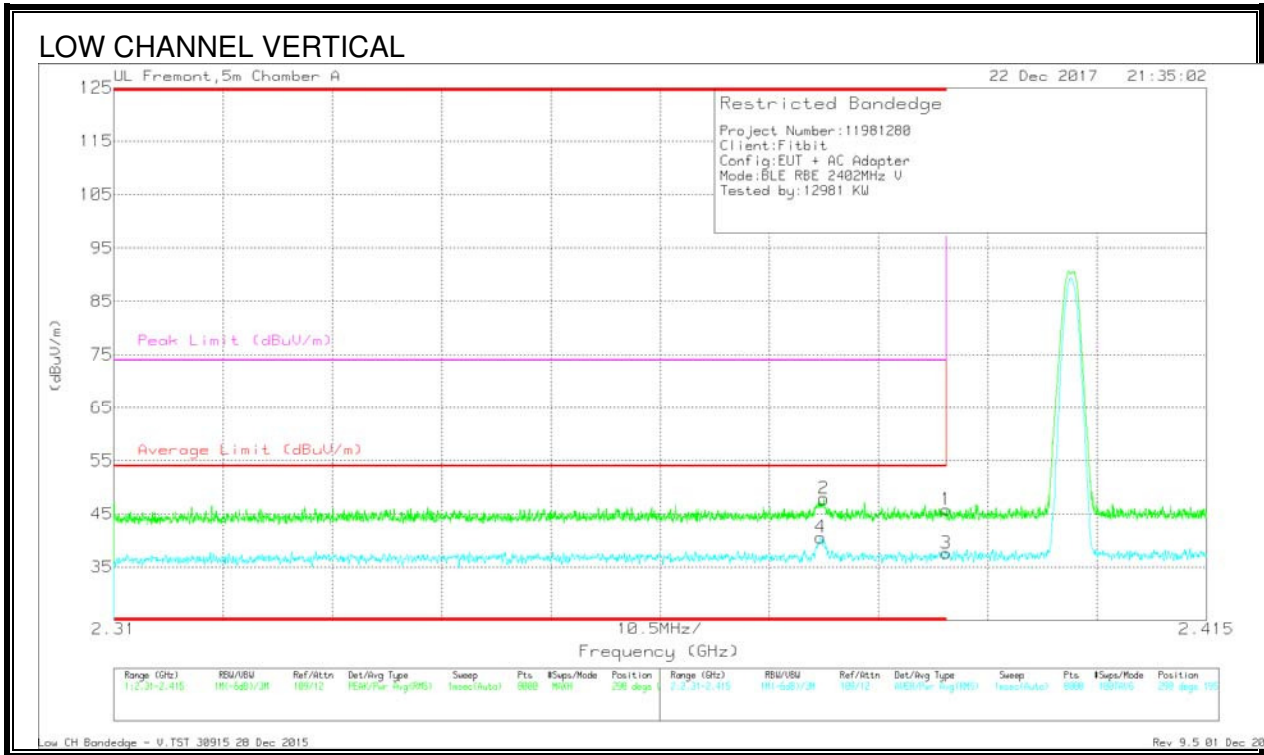

DATA

Marker	Frequency (GHz)	Meter Reading (dBuV)	Det	AF T862 (dB/m)	Amp/Cbl/Filtr/Pad (dB)	DC Corr (dB)	Corrected Reading (dBuV/m)	Average Limit (dBuV/m)	Margin (dB)	Peak Limit (dBuV/m)	PK Margin (dB)	Azimuth (Degs)	Height (cm)	Polarity
2	* 2.378	39.54	Pk	31.7	-23.4	0	47.84	-	-	74	-26.16	298	195	V
4	* 2.378	30.22	RMS	31.7	-23.4	2.06	40.58	54	-13.42	-	-	298	195	V
1	* 2.39	37.29	Pk	31.8	-23.3	0	45.79	-	-	74	-28.21	298	195	V
3	* 2.39	27.03	RMS	31.8	-23.3	2.06	37.59	54	-16.41	-	-	298	195	V

* - indicates frequency in CFR47 Pt 15 / IC RSS-Restricted Band

Pk - Peak detector

RMS - RMS detection

9.2.2. AUTHORIZED BANDEDGE (HIGH CHANNEL)

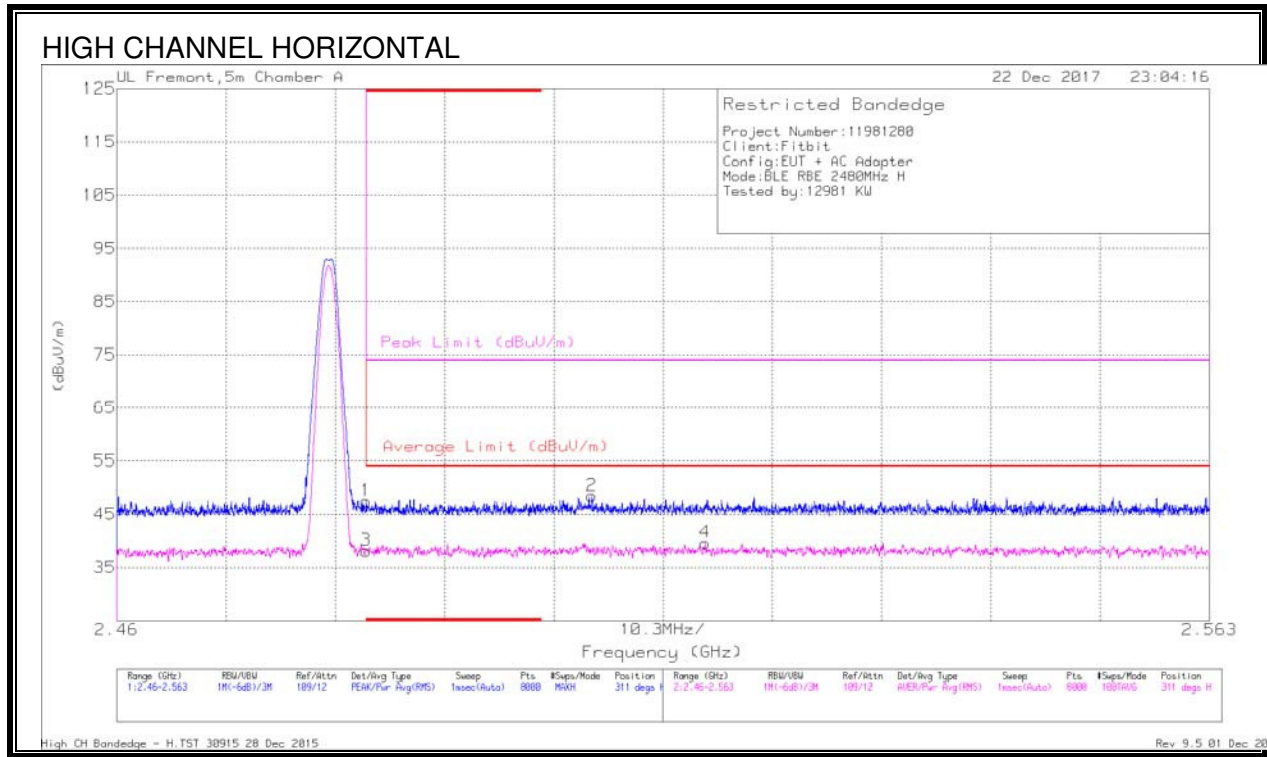

DATA

Marker	Frequency (GHz)	Meter Reading (dBuV)	Det	AF T862 (dB/m)	Amp/Cb/Filtr/Pad (dB)	DC Corr (dB)	Corrected Reading (dBuV/m)	Average Limit (dBuV/m)	Margin (dB)	Peak Limit (dBuV/m)	PK Margin (dB)	Azimuth (Degs)	Height (cm)	Polarity
1	* 2.484	38.33	Pk	32.3	-23.2	0	47.43	-	-	74	-26.57	311	208	H
3	* 2.484	27.02	RMS	32.3	-23.2	2.06	38.18	54	-15.82	-	-	311	208	H
2	2.505	39.22	Pk	32.4	-23.2	0	48.42	-	-	74	-25.58	311	208	H
4	2.515	28.37	RMS	32.4	-23.2	2.06	39.63	54	-14.37	-	-	311	208	H

* - indicates frequency in CFR47 Pt 15 / IC RSS-Restricted Band
 Pk - Peak detector
 RMS - RMS detection

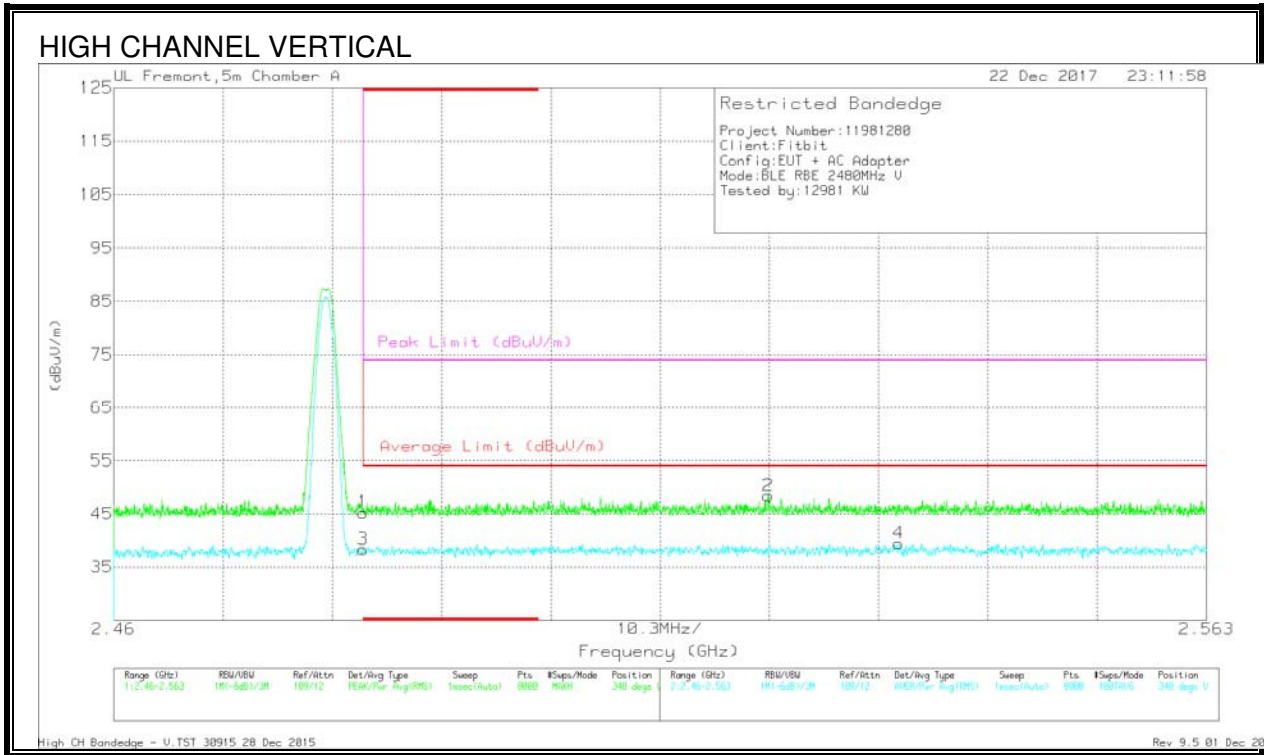

DATA

Marker	Frequency (GHz)	Meter Reading (dBuV)	Det	AF T862 (dB/m)	Amp/Cbl/Filtr/Pad (dB)	DC Corr (dB)	Corrected Reading (dBuV/m)	Average Limit (dBuV/m)	Margin (dB)	Peak Limit (dBuV/m)	PK Margin (dB)	Azimuth (Degs)	Height (cm)	Polarity
1	* 2.484	36.12	Pk	32.3	-23.2	0	45.22	-	-	74	-28.78	340	189	V
3	* 2.484	27.19	RMS	32.3	-23.2	2.06	38.35	54	-15.65	-	-	340	189	V
2	2.522	39.14	Pk	32.4	-23.2	0	48.34	-	-	74	-25.66	340	189	V
4	2.534	28.08	RMS	32.4	-23.1	2.06	39.44	54	-14.56	-	-	340	189	V

* - indicates frequency in CFR47 Pt 15 / IC RSS-Restricted Band

Pk - Peak detector

RMS - RMS detection

9.2.3. HARMONICS AND SPURIOUS EMISSIONS

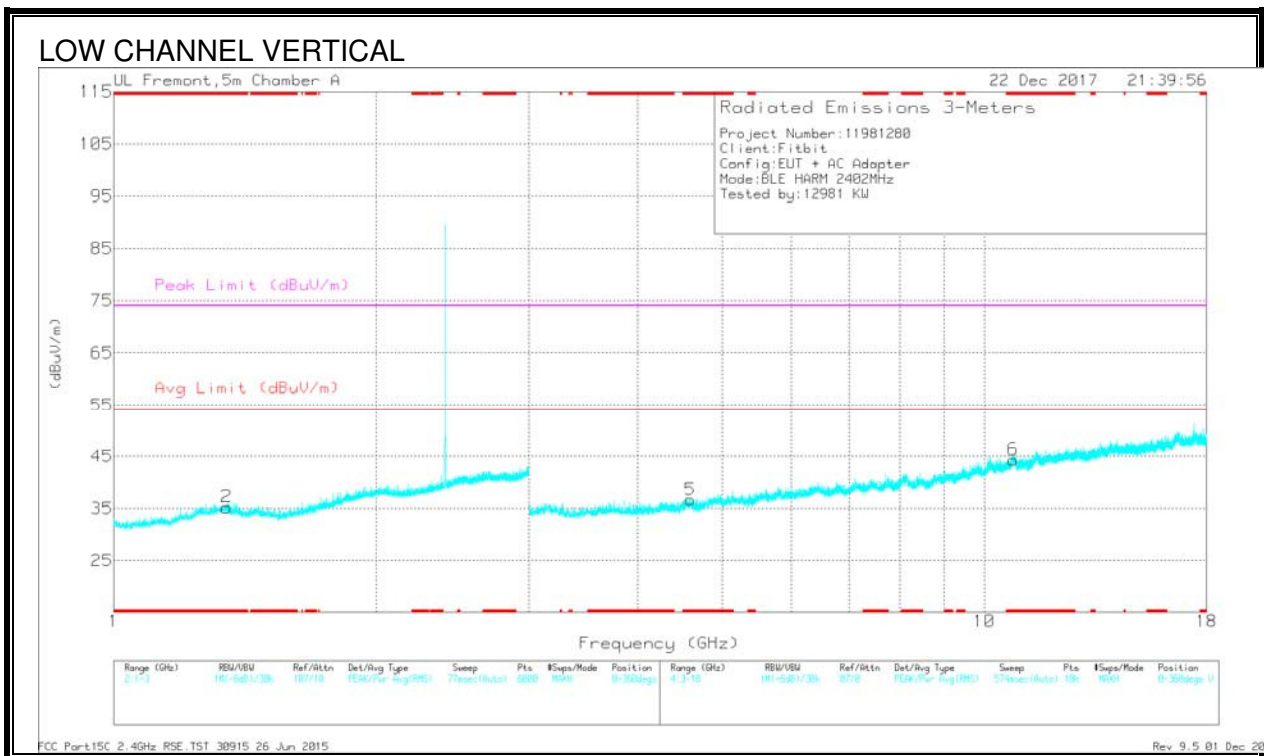
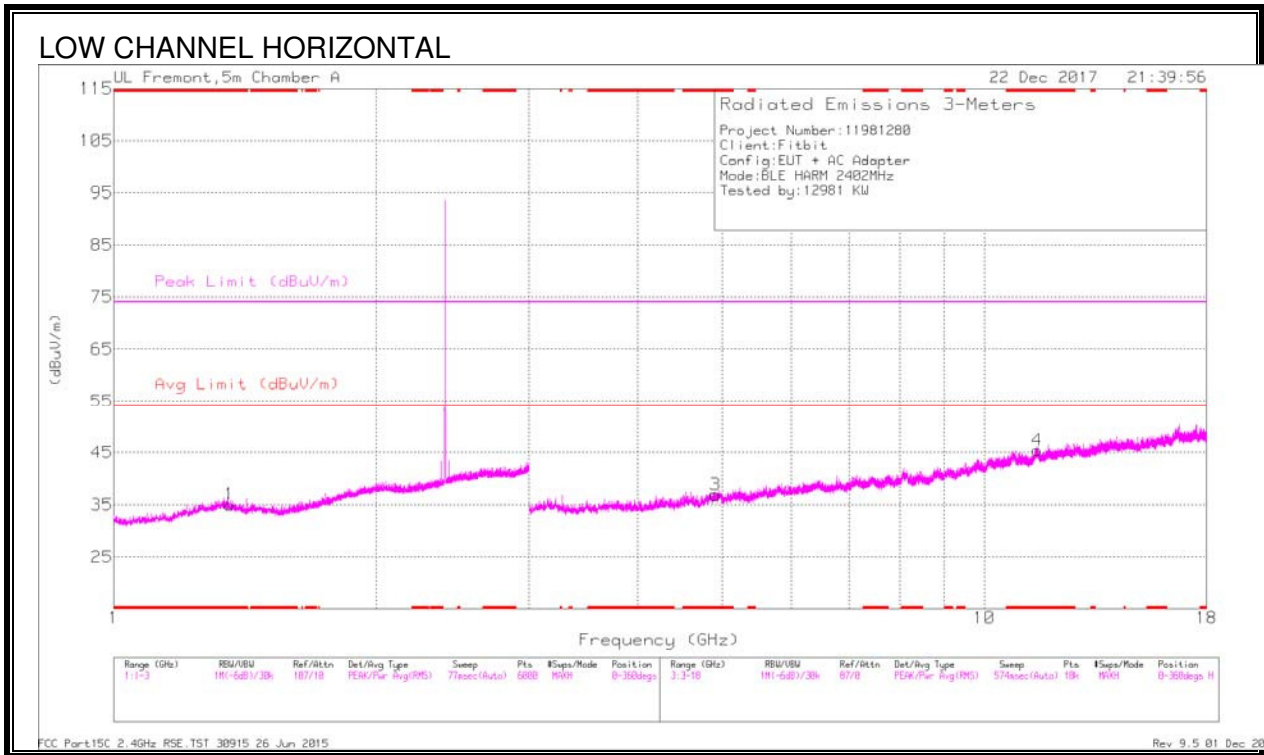

DATA

Frequency (GHz)	Meter Reading (dBuV)	Det	AF T862 (dB/m)	Amp/Cbl/Filtr/Pad (dB)	DC Corr (dB)	Corrected Reading (dBuV/m)	Avg Limit (dBuV/m)	Margin (dB)	Peak Limit (dBuV/m)	PK Margin (dB)	Azimuth (Degs)	Height (cm)	Polarity
* 1.359	35.42	PK2	29.3	-23.5	0	41.22	-	-	74	-32.78	260	151	H
* 1.358	24.21	MAv1	29.4	-23.5	2.06	32.17	54	-21.83	-	-	260	151	H
* 1.347	35.81	PK2	29.5	-23.5	0	41.81	-	-	74	-32.19	165	112	V
* 1.349	24.28	MAv1	29.5	-23.5	2.06	32.34	54	-21.66	-	-	165	112	V
* 4.912	35.89	PK2	34.1	-26.3	0	43.69	-	-	74	-30.31	195	176	H
* 4.912	24.85	MAv1	34.1	-26.3	2.06	34.71	54	-19.29	-	-	195	176	H
* 11.504	32.2	PK2	38.3	-18.5	0	52	-	-	74	-22	60	116	H
* 11.505	20.9	MAv1	38.3	-18.5	2.06	42.76	54	-11.24	-	-	60	116	H
* 4.598	35.62	PK2	34.1	-27	0	42.72	-	-	74	-31.28	162	187	V
* 4.599	25.13	MAv1	34.1	-27	2.06	34.29	54	-19.71	-	-	162	187	V
* 10.793	31.68	PK2	37.8	-18.6	0	50.88	-	-	74	-23.12	85	256	V
* 10.794	21.02	MAv1	37.8	-18.6	2.06	42.28	54	-11.72	-	-	85	256	V

* - indicates frequency in CFR47 Pt 15 / IC RSS-Restricted Band

PK2 - KDB558074 Method: Maximum Peak

MAv1 - KDB558074 Option 1 Maximum RMS Average

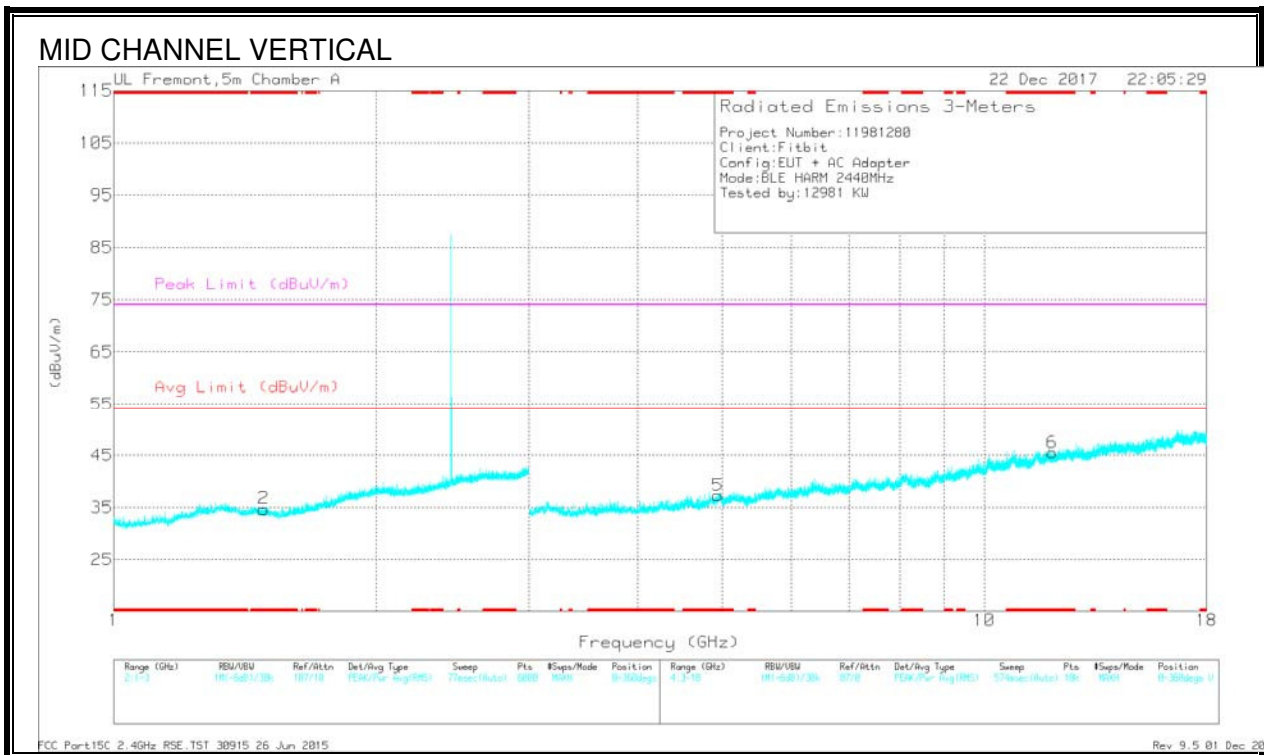
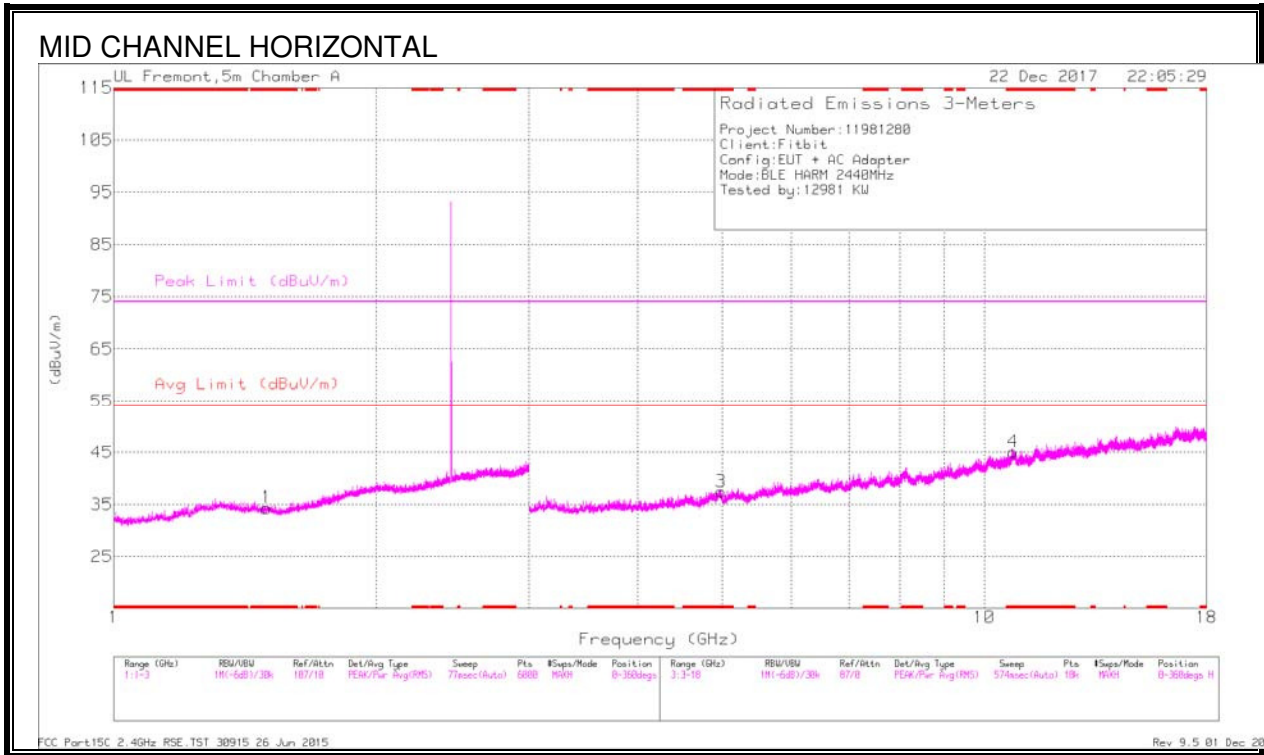

DATA

Frequency (GHz)	Meter Reading (dBuV)	Det	AF T862 (dB/m)	Amp/Cbl/Filtr/Pad (dB)	DC Corr (dB)	Corrected Reading (dBuV/m)	Avg Limit (dBuV/m)	Margin (dB)	Peak Limit (dBuV/m)	PK Margin (dB)	Azimuth (Degs)	Height (cm)	Polarity
* 1.496	36.19	PK2	28.4	-23.4	0	41.19	-	-	74	-32.81	153	175	H
* 1.497	24.43	MAv1	28.4	-23.4	2.06	31.49	54	-22.51	-	-	153	175	H
* 1.488	36.37	PK2	28.5	-23.4	0	41.47	-	-	74	-32.53	72	230	V
* 1.486	24.32	MAv1	28.5	-23.4	2.06	31.48	54	-22.52	-	-	72	230	V
* 4.983	37.15	PK2	34.3	-27.3	0	44.15	-	-	74	-29.85	181	166	H
* 4.984	25.99	MAv1	34.3	-27.3	2.06	35.05	54	-18.95	-	-	181	166	H
* 10.796	32.42	PK2	37.8	-18.7	0	51.52	-	-	74	-22.48	56	173	H
* 10.794	20.7	MAv1	37.8	-18.6	2.06	41.96	54	-12.04	-	-	56	173	H
* 4.943	35.64	PK2	34.2	-26.8	0	43.04	-	-	74	-30.96	225	213	V
* 4.946	24.97	MAv1	34.2	-26.8	2.06	34.43	54	-19.57	-	-	225	213	V
* 11.973	31.65	PK2	38.9	-19	0	51.55	-	-	74	-22.45	167	152	V
* 11.972	20.68	MAv1	38.9	-19	2.06	42.64	54	-11.36	-	-	167	152	V

* - indicates frequency in CFR47 Pt 15 / IC RSS-Restricted Band

PK2 - KDB558074 Method: Maximum Peak

MAv1 - KDB558074 Option 1 Maximum RMS Average

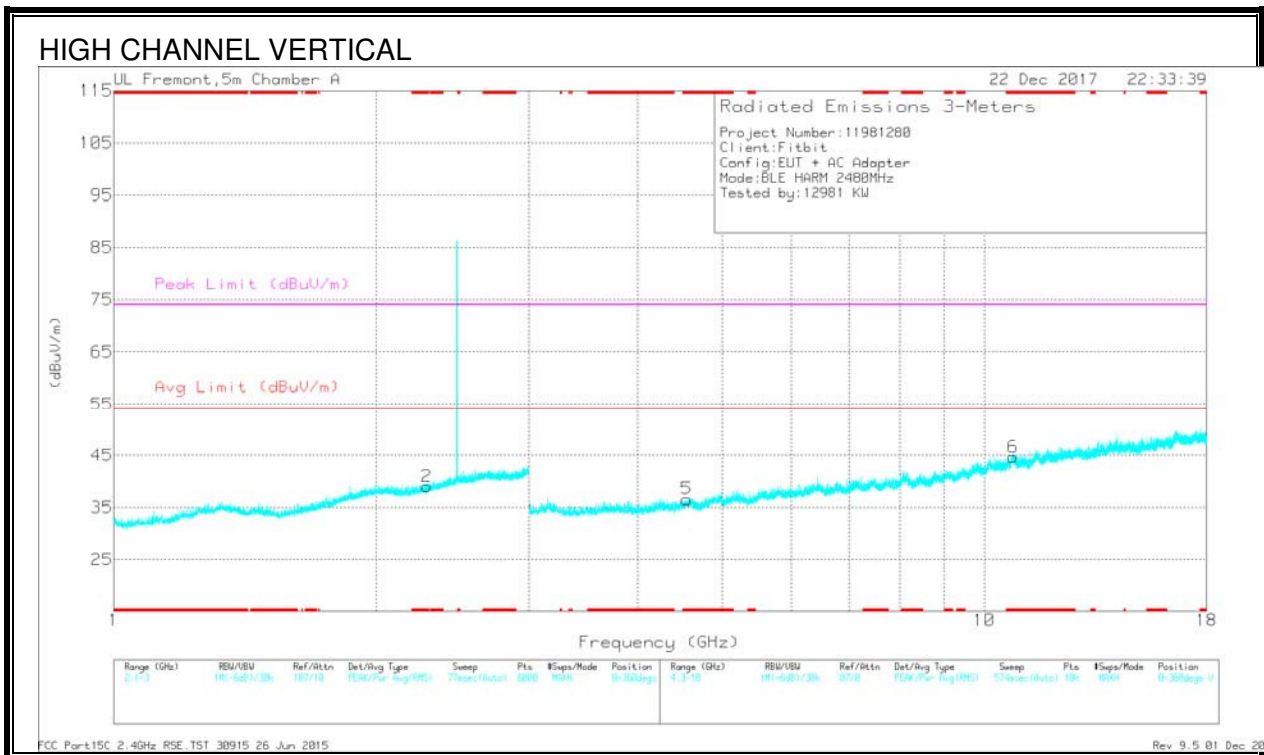
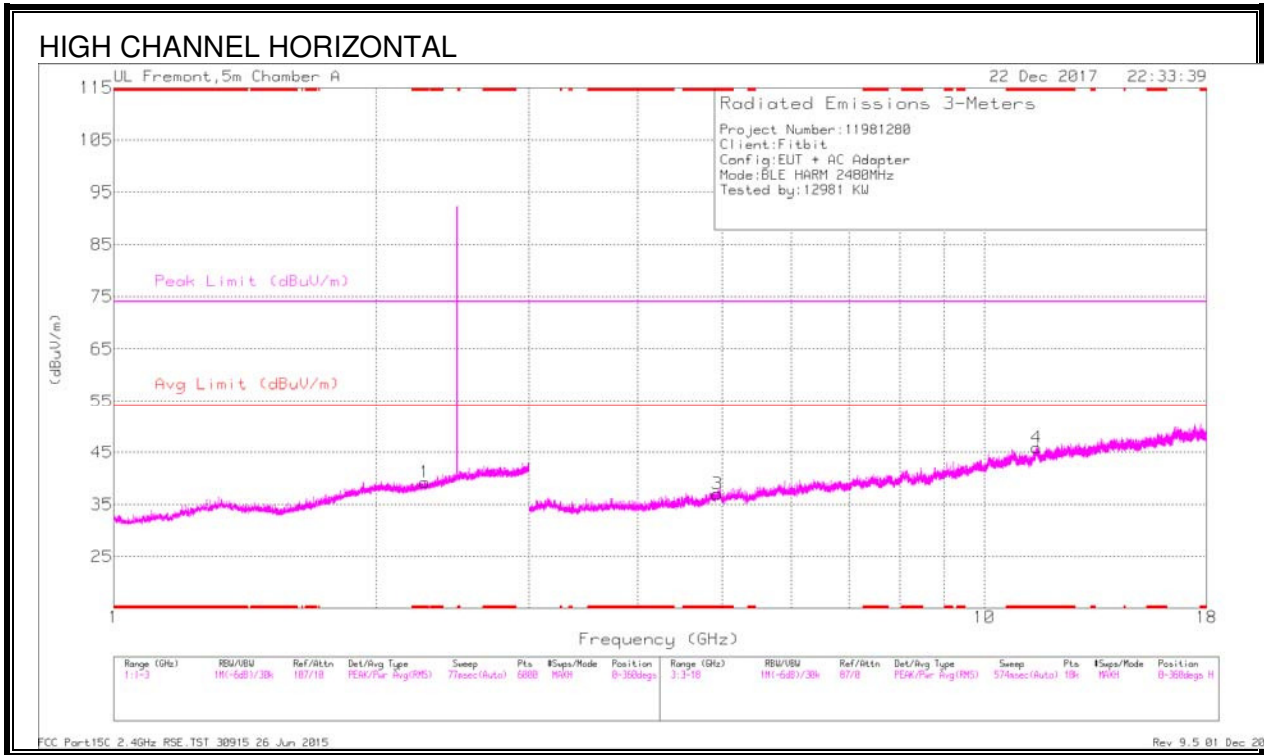

DATA

Frequency (GHz)	Meter Reading (dBuV)	Det	AF T862 (dB/m)	Amp/Cbl/Filtr/Pad (dB)	DC Corr (dB)	Corrected Reading (dBuV/m)	Avg Limit (dBuV/m)	Margin (dB)	Peak Limit (dBuV/m)	PK Margin (dB)	Azimuth (Degs)	Height (cm)	Polarity
* 2.28	37.36	PK2	31.5	-23.5	0	45.36	-	-	74	-28.64	120	127	H
* 2.279	25.52	MAv1	31.5	-23.5	2.06	35.58	54	-18.42	-	-	120	127	H
* 2.286	36.85	PK2	31.5	-23.5	0	44.85	-	-	74	-29.15	98	149	V
* 2.289	25.4	MAv1	31.5	-23.5	2.06	35.46	54	-18.54	-	-	98	149	V
* 4.937	36.41	PK2	34.2	-26.9	0	43.71	-	-	74	-30.29	115	240	H
* 4.936	25.08	MAv1	34.2	-26.8	2.06	34.54	54	-19.46	-	-	115	240	H
* 11.483	31.63	PK2	38.3	-18.1	0	51.83	-	-	74	-22.17	79	228	H
* 11.483	20.83	MAv1	38.3	-18.1	2.06	43.09	54	-10.91	-	-	79	228	H
* 4.554	36.83	PK2	34	-26.9	0	43.93	-	-	74	-30.07	138	182	V
* 4.554	25.39	MAv1	34	-26.9	2.06	34.55	54	-19.45	-	-	138	182	V
* 10.791	31.6	PK2	37.8	-18.5	0	50.9	-	-	74	-23.1	263	124	V
* 10.793	20.89	MAv1	37.8	-18.6	2.06	42.15	54	-11.85	-	-	263	124	V

* - indicates frequency in CFR47 Pt 15 / IC RSS-Restricted Band

PK2 - KDB558074 Method: Maximum Peak

MAv1 - KDB558074 Option 1 Maximum RMS Average

9.3. WORST-CASE BELOW 30MHz

SPURIOUS EMISSIONS BELOW 30 MHz (WORST-CASE CONFIGURATION)

HORIZONTAL PLOT

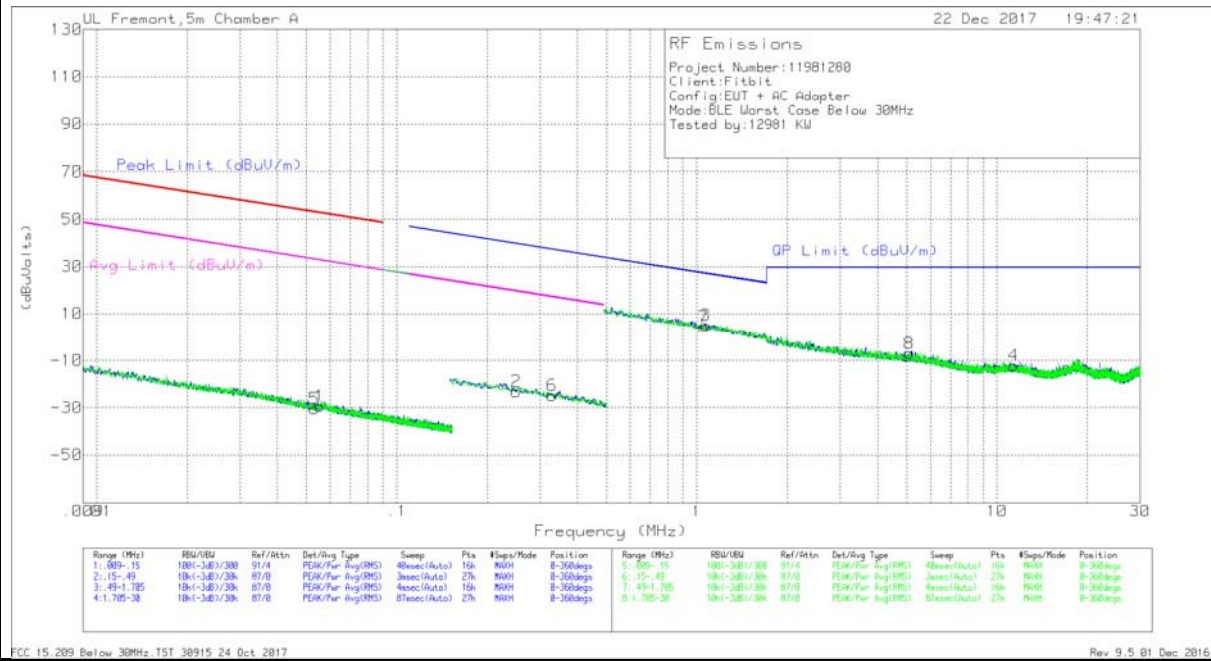

VERTICAL PLOT

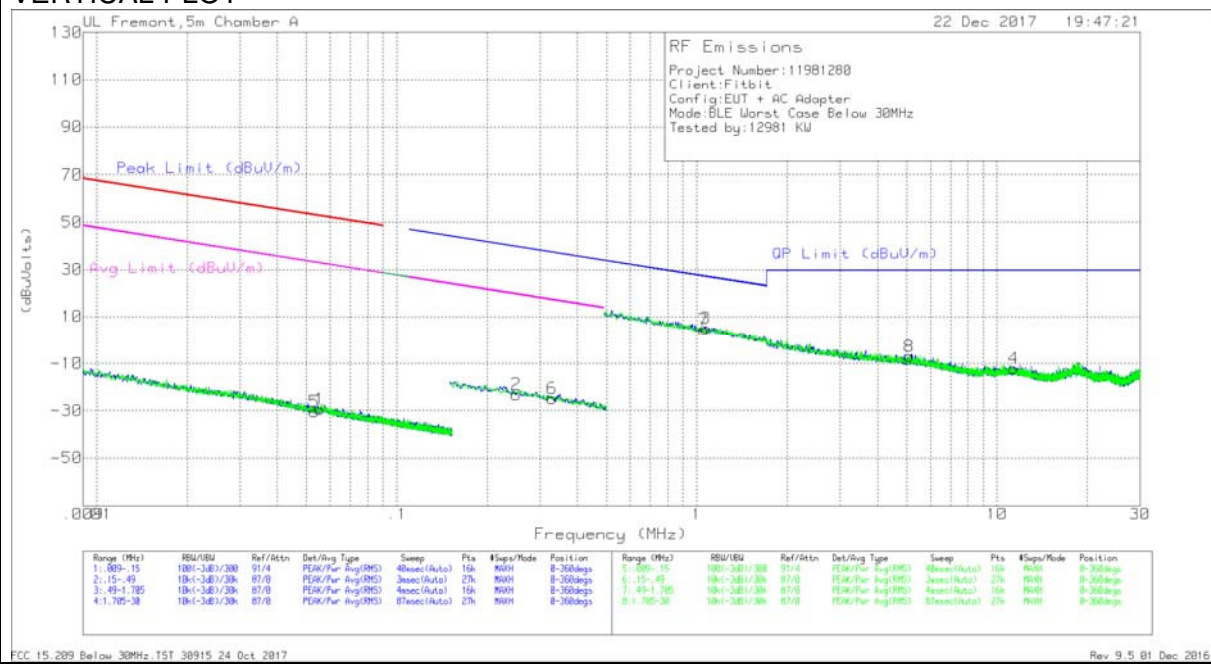

DATA

Marker	Frequency (MHz)	Meter Reading (dBuV)	Det	Loop Antenna (dB/m)	Cbl (dB)	Dist Corr 300m	Corrected Reading (dBuVolts)	Peak Limit (dBuV/m)	Margin (dB)	Avg Limit (dBuV/m)	Margin (dB)	Peak Limit (dBuV/m)	Margin (dB)	Avg Limit (dBuV/m)	Margin (dB)	Azimuth (Degs)
5	.05316	34.95	Pk	14.4	.1	-80	-30.55	53.07	-83.62	33.07	-63.62	-	-	-	-	0-360
1	.05549	36.11	Pk	14.4	.1	-80	-29.39	52.7	-82.09	32.7	-62.09	-	-	-	-	0-360
2	.25007	42.95	Pk	13.8	.1	-80	-23.15	-	-	-	-	39.65	-62.8	19.65	-42.8	0-360
6	.32909	41.21	Pk	13.8	.1	-80	-24.89	-	-	-	-	37.26	-62.15	17.26	-42.15	0-360

Marker	Frequency (MHz)	Meter Reading (dBuV)	Det	Loop Antenna (dB/m)	Cbl (dB)	Dist Corr 30m	Corrected Reading (dBuVolts)	QP Limit (dBuV/m)	Margin (dB)	Azimuth (Degs)
7	1.05263	29.85	Pk	14.3	.2	-40	4.35	27.18	-22.83	0-360
3	1.06798	30.69	Pk	14.3	.2	-40	5.19	27.05	-21.86	0-360
8	5.10052	18.12	Pk	14.4	.3	-40	-7.18	29.5	-36.68	0-360
4	11.36127	12.76	Pk	14.7	.5	-40	-12.04	29.5	-41.54	0-360

Pk - Peak detector

9.4. WORST-CASE 30MHz TO 1GHz

SPURIOUS EMISSIONS 30 TO 1000 MHz (WORST-CASE CONFIGURATION)

HORIZONTAL PLOT

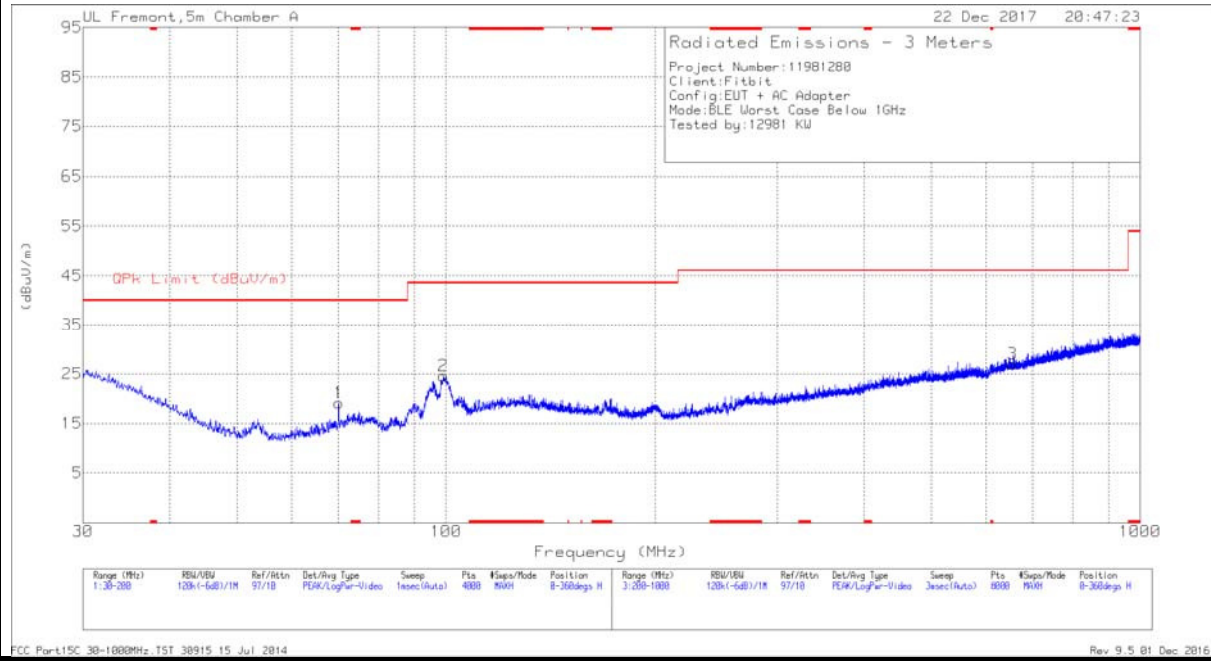

VERTICAL PLOT

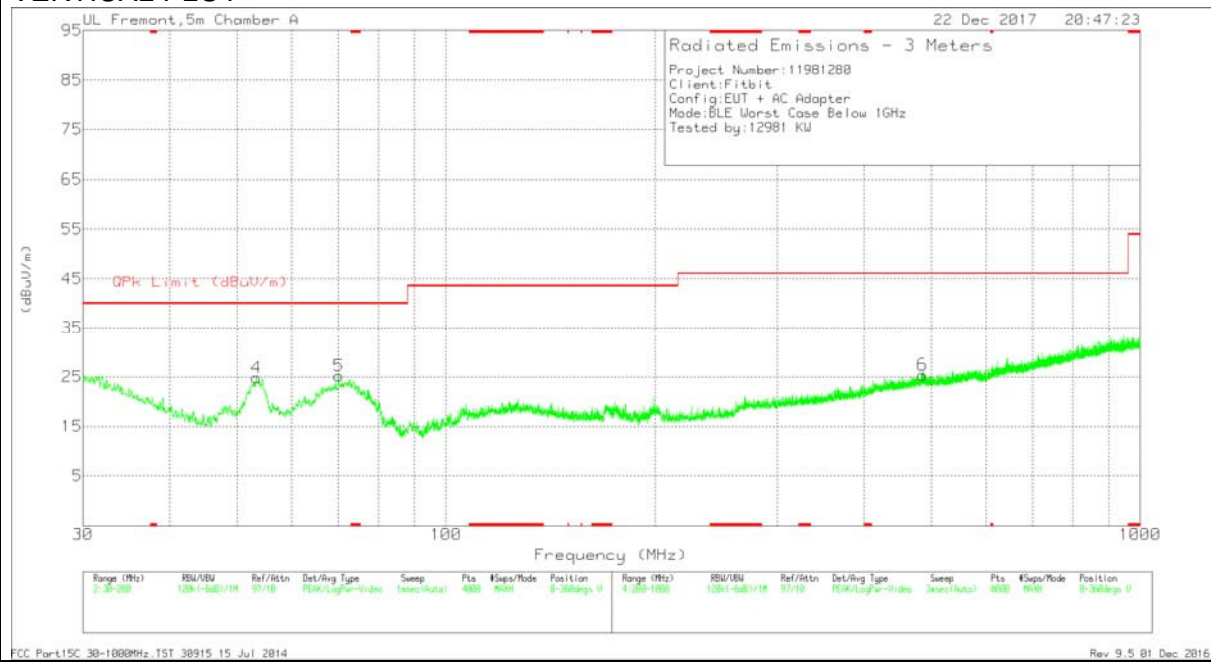

DATA

Marker	Frequency (MHz)	Meter Reading (dBuV)	Det	AF T130 (dB/m)	Amp/Cbl (dB/m)	Corrected Reading (dBuV/m)	QPk Limit (dBuV/m)	Margin (dB)	Azimuth (Degs)	Height (cm)	Polarity
4	53.3385	40.75	Pk	11.1	-27	24.85	40	-15.15	0-360	100	V
1	70.0454	33.7	Pk	12.1	-26.7	19.1	40	-20.9	0-360	100	H
5	70.0454	39.79	Pk	12.1	-26.7	25.19	40	-14.81	0-360	100	V
2	99.1654	37.04	Pk	13.9	-26.4	24.54	43.52	-18.98	0-360	300	H
6	485.5371	28.91	Pk	21.7	-25.2	25.41	46.02	-20.61	0-360	200	V
3	655.0592	28.03	Pk	23.8	-24.8	27.03	46.02	-18.99	0-360	400	H

Pk - Peak detector

9.5. WORST-CASE ABOVE 18 GHz

SPURIOUS EMISSIONS 18 TO 26 GHz (WORST-CASE CONFIGURATION)

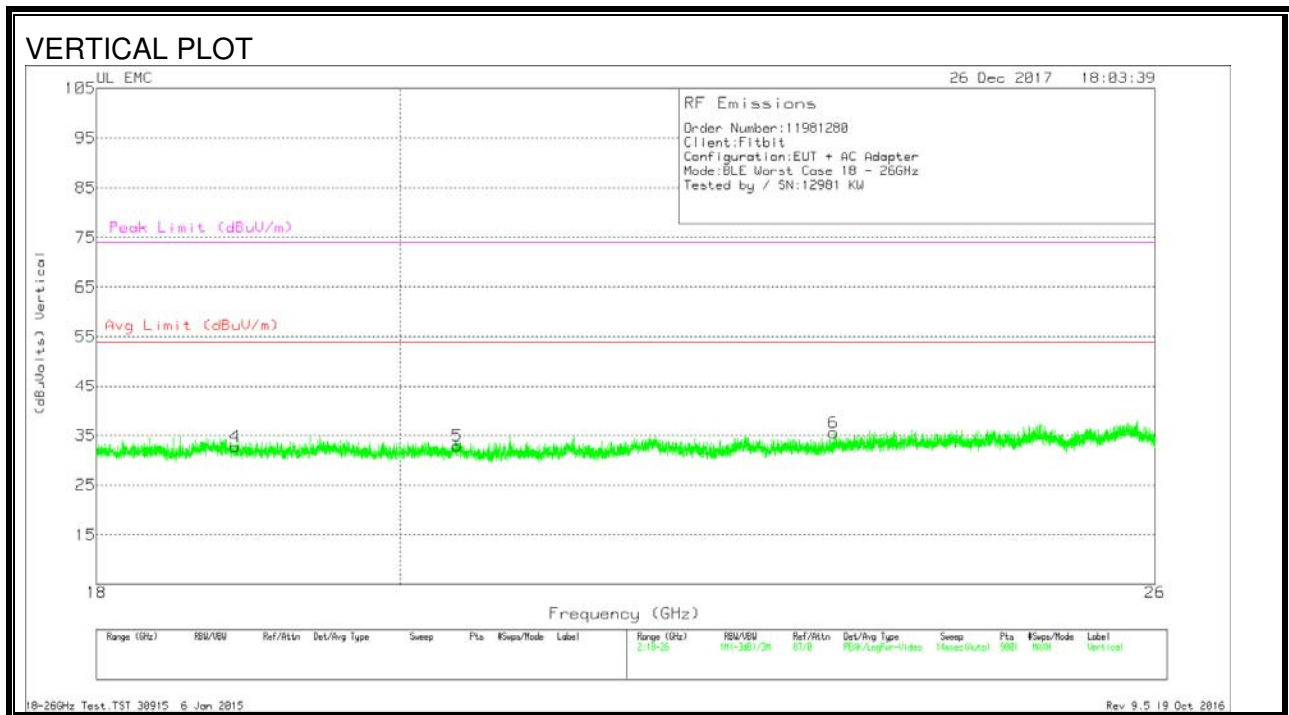
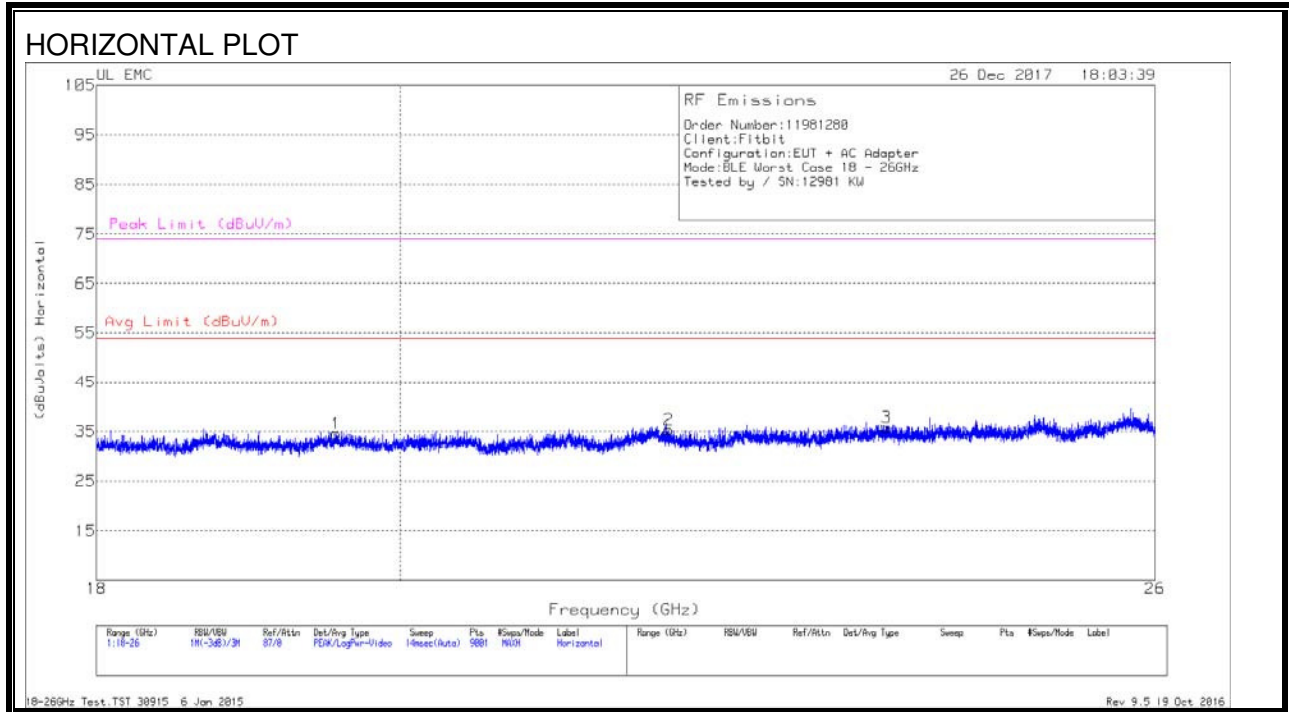

DATA

Marker	Frequency (GHz)	Meter Reading (dBuV)	Det	T89 AF (dB/m)	Amp/Cbl (dB)	Dist Corr (dB)	Corrected Reading (dBuVolts)	Avg Limit (dBuV/m)	Margin (dB)	Peak Limit (dBuV/m)	PK Margin (dB)
1	19.562	36.6	Pk	32.5	-25.1	-9.5	34.5	54	-19.5	74	-39.5
2	21.957	36.73	Pk	33.3	-25.2	-9.5	35.33	54	-18.67	74	-38.67
3	23.684	36.12	Pk	33.6	-24.4	-9.5	35.82	54	-18.18	74	-38.18
4	18.889	35.38	Pk	32.3	-25.4	-9.5	32.78	54	-21.22	74	-41.22
5	20.404	34.96	Pk	32.6	-25.1	-9.5	32.96	54	-21.04	74	-41.04
6	23.251	36.56	Pk	33.5	-25	-9.5	35.56	54	-18.44	74	-38.44

Pk - Peak detector

10. AC POWER LINE CONDUCTED EMISSIONS

LIMITS

FCC §15.207 (a)

RSS-Gen 8.8

Frequency of Emission (MHz)	Conducted Limit (dB μ V)	
	Quasi-peak	Average
0.15-0.5	66 to 56 *	56 to 46 *
0.5-5	56	46
5-30	60	50

*Decreases with the logarithm of the frequency.

TEST PROCEDURE

The EUT is placed on a non-conducting table 40 cm from the vertical ground plane and 80 cm above the horizontal ground plane. The EUT is configured in accordance with ANSI C63.10.

The receiver is set to a resolution bandwidth of 9 kHz. Peak detection is used unless otherwise noted as quasi-peak or average.

Line conducted data is recorded for both NEUTRAL and HOT lines.

RESULTS

10.1.1. EUT POWERED BY AC/DC ADAPTER VIA USB CABLE

LINE 1 RESULTS

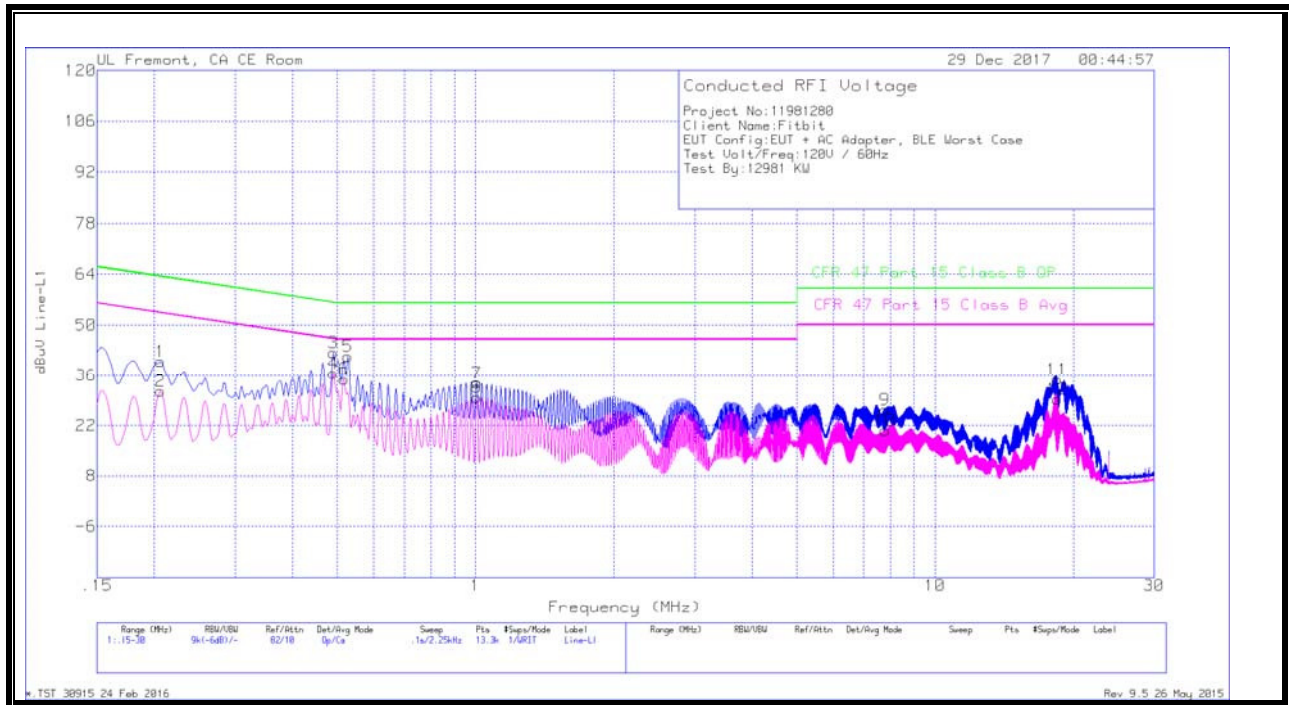

WORST EMISSIONS

Range 1: Line-L1 .15 - 30MHz											
Marker	Frequency (MHz)	Meter Reading (dBuV)	Det	LISN L1	LC Cables C1&C3	Limiter (dB)	Corrected Reading dBuV	CFR 47 Part 15 Class B QP	QP Margin (dB)	CFR 47 Part 15 Class B Avg	Av(CISPR) Margin (dB)
1	.20625	29.88	Qp	0	0	10.1	39.98	63.35	-23.37	-	-
2	.20625	21.41	Ca	0	0	10.1	31.51	-	-	53.35	-21.84
3	.48975	32.3	Qp	0	0	10.1	42.4	56.17	-13.77	-	-
4	.48975	26.44	Ca	0	0	10.1	36.54	-	-	46.17	-9.63
5	.528	31.24	Qp	0	0	10.1	41.34	56	-14.66	-	-
6	.51675	24.86	Ca	0	0	10.1	34.96	-	-	46	-11.04
7	1.005	23.68	Qp	0	.1	10.1	33.88	56	-22.12	-	-
8	1.005	19.61	Ca	0	.1	10.1	29.81	-	-	46	-16.19
9	7.77075	15.9	Qp	0	.2	10.2	26.3	60	-33.7	-	-
10	7.79325	10.25	Ca	0	.2	10.2	20.65	-	-	50	-29.35
11	18.456	24.24	Qp	0	.3	10.3	34.84	60	-25.16	-	-
12	18.456	18.69	Ca	0	.3	10.3	29.29	-	-	50	-20.71

Qp - Quasi-Peak detector

Ca - CISPR average detection

LINE 2 RESULTS

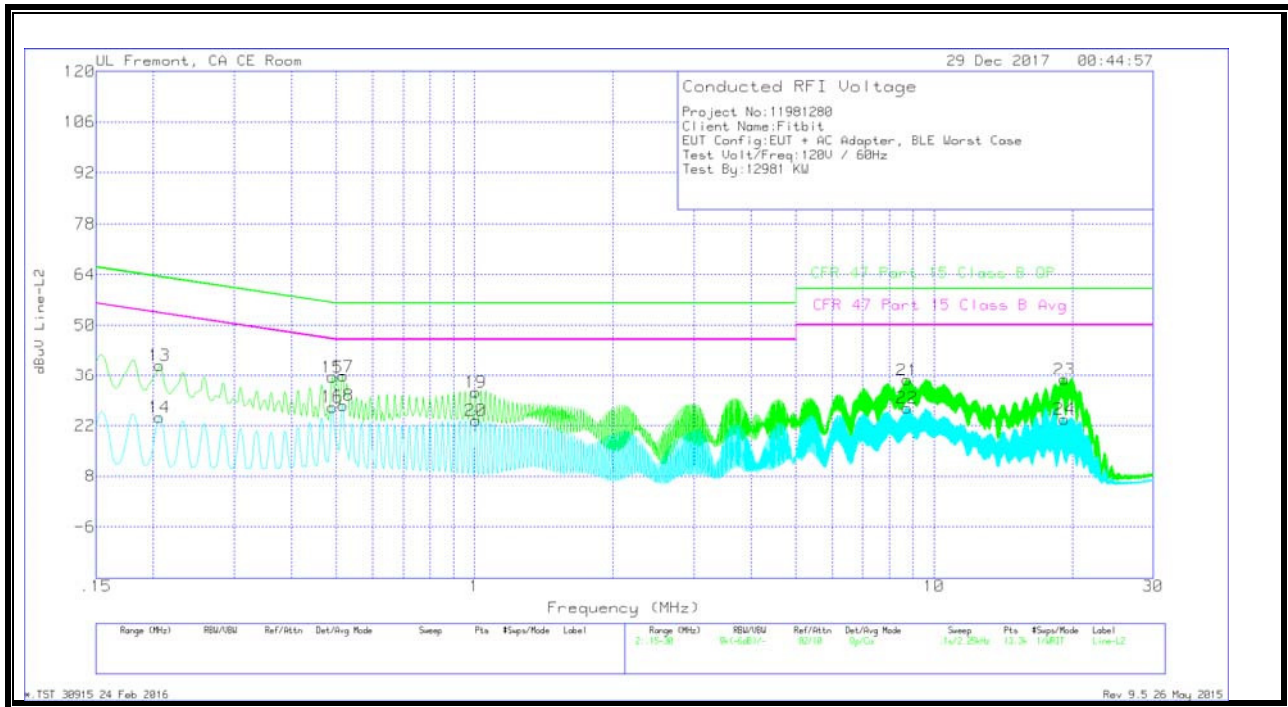

WORST EMISSIONS

Range 2: Line-L2 .15 - 30MHz											
Marker	Frequency (MHz)	Meter Reading (dBuV)	Det	LISN L2	LC Cables C2&C3	Limiters (dB)	Corrected Reading dBuV	CFR 47 Part 15 Class B QP	QP Margin (dB)	CFR 47 Part 15 Class B Avg	Av(CISPR) Margin (dB)
13	.20625	28.75	Qp	0	0	10.1	38.85	63.35	-24.5	-	-
14	.20625	14.18	Ca	0	0	10.1	24.28	-	-	53.35	-29.07
15	.48975	25.39	Qp	0	0	10.1	35.49	56.17	-20.68	-	-
16	.48975	17.04	Ca	0	0	10.1	27.14	-	-	46.17	-19.03
17	.51675	25.67	Qp	0	0	10.1	35.77	56	-20.23	-	-
18	.51675	17.5	Ca	0	0	10.1	27.6	-	-	46	-18.4
19	1.005	21.04	Qp	0	.1	10.1	31.24	56	-24.76	-	-
20	1.005	13.25	Ca	0	.1	10.1	23.45	-	-	46	-22.55
21	8.73825	24.37	Qp	0	.2	10.2	34.77	60	-25.23	-	-
22	8.73825	16.43	Ca	0	.2	10.2	26.83	-	-	50	-23.17
23	19.22775	24.29	Qp	0	.3	10.3	34.89	60	-25.11	-	-
24	19.22775	13.16	Ca	0	.3	10.3	23.76	-	-	50	-26.24

Qp - Quasi-Peak detector

Ca - CISPR average detection