

EMC Test Report

Application for Grant of Equipment Authorization

Industry Canada RSS-Gen Issue 3 / RSS 210 Issue 8 FCC Part 15 Subpart C

Model: FB501

IC CERTIFICATION #: 8542A-FB501
FCC ID: XRAFB501

APPLICANT: Fitbit, Inc.
405 Howard Street
San Francisco, CA 94105

TEST SITE(S): National Technical Systems - Silicon Valley
41039 Boyce Road.
Fremont, CA. 94538-2435

IC SITE REGISTRATION #: 2845B-3; 2845B-5, 2845B-7

REPORT DATE: August 12, 2014

REISSUE DATE: September 5, 2014

FINAL TEST DATES: July 7, 29 and 30, 2014

TOTAL NUMBER OF PAGES: 52

PROGRAM MGR /
TECHNICAL REVIEWER:



Mark E Hill
Staff Engineer

QUALITY ASSURANCE DELEGATE /
FINAL REPORT PREPARER:



David Guidotti
Senior Technical Writer



National Technical Systems - Silicon Valley is accredited by the A2LA, certificate number 0214.26, to perform the test(s) listed in this report, except where noted otherwise. This report and the information contained herein represent the results of testing test articles identified and selected by the client performed to specifications and/or procedures selected by the client. National Technical Systems (NTS) makes no representations, expressed or implied, that such testing is adequate (or inadequate) to demonstrate efficiency, performance, reliability, or any other characteristic of the articles being tested, or similar products. This report should not be relied upon as an endorsement or certification by NTS of the equipment tested, nor does it represent any statement whatsoever as to its merchantability or fitness of the test article, or similar products, for a particular purpose. This report shall not be reproduced except in full

REVISION HISTORY

Rev#	Date	Comments	Modified By
-	August 12, 2014	First release	
1	August 19, 2014	Reissued to add data	Dave Guidotti
2	September 5, 2014	Fixed error in the calibration of equipment used during testing	Mark Hill

TABLE OF CONTENTS

REVISION HISTORY	2
TABLE OF CONTENTS	3
SCOPE.....	4
OBJECTIVE	4
STATEMENT OF COMPLIANCE.....	5
DEVIATIONS FROM THE STANDARDS.....	5
TEST RESULTS SUMMARY	6
DIGITAL TRANSMISSION SYSTEMS (2400 – 2483.5MHZ).....	6
GENERAL REQUIREMENTS APPLICABLE TO ALL BANDS.....	6
MEASUREMENT UNCERTAINTIES.....	7
EQUIPMENT UNDER TEST (EUT) DETAILS.....	8
GENERAL.....	8
OTHER EUT DETAILS.....	8
ANTENNA SYSTEM	8
ENCLOSURE.....	8
MODIFICATIONS.....	8
SUPPORT EQUIPMENT.....	9
EUT INTERFACE PORTS	9
EUT OPERATION	9
TEST SITE.....	10
GENERAL INFORMATION.....	10
CONDUCTED EMISSIONS CONSIDERATIONS	10
RADIATED EMISSIONS CONSIDERATIONS	10
MEASUREMENT INSTRUMENTATION	11
RECEIVER SYSTEM	11
INSTRUMENT CONTROL COMPUTER	11
LINE IMPEDANCE STABILIZATION NETWORK (LISN).....	11
FILTERS/ATTENUATORS	12
ANTENNAS.....	12
ANTENNA MAST AND EQUIPMENT TURNTABLE.....	12
INSTRUMENT CALIBRATION.....	12
TEST PROCEDURES	13
EUT AND CABLE PLACEMENT	13
CONDUCTED EMISSIONS.....	13
RADIATED EMISSIONS	13
CONDUCTED EMISSIONS FROM ANTENNA PORT	16
BANDWIDTH MEASUREMENTS	16
SPECIFICATION LIMITS AND SAMPLE CALCULATIONS	17
CONDUCTED EMISSIONS SPECIFICATION LIMITS: FCC 15.207; FCC 15.107(A), RSS GEN	17
GENERAL TRANSMITTER RADIATED EMISSIONS SPECIFICATION LIMITS	18
OUTPUT POWER LIMITS – DIGITAL TRANSMISSION SYSTEMS	19
TRANSMIT MODE SPURIOUS RADIATED EMISSIONS LIMITS – FHSS AND DTS SYSTEMS.....	19
SAMPLE CALCULATIONS - CONDUCTED EMISSIONS	19
SAMPLE CALCULATIONS - RADIATED EMISSIONS.....	20
SAMPLE CALCULATIONS - FIELD STRENGTH TO EIRP CONVERSION.....	21
APPENDIX A TEST EQUIPMENT CALIBRATION DATA	22
APPENDIX B TEST DATA	23
END OF REPORT	52

SCOPE

An electromagnetic emissions test has been performed on the Fitbit, Inc. model FB501, pursuant to the following rules:

Industry Canada RSS-Gen Issue 3
RSS 210 Issue 8 “Low-power Licence-exempt Radiocommunication Devices (All Frequency Bands): Category I Equipment”
FCC Part 15 Subpart C

Conducted and radiated emissions data has been collected, reduced, and analyzed within this report in accordance with measurement guidelines set forth in the following reference standards and as outlined in National Technical Systems - Silicon Valley test procedures:

ANSI C63.10-2009
FCC DTS Measurement Guidance KDB558074

The intentional radiator above has been tested in a simulated typical installation to demonstrate compliance with the relevant Industry Canada performance and procedural standards.

Final system data was gathered in a mode that tended to maximize emissions by varying orientation of EUT, orientation of power and I/O cabling, antenna search height, and antenna polarization.

Every practical effort was made to perform an impartial test using appropriate test equipment of known calibration. All pertinent factors have been applied to reach the determination of compliance.

OBJECTIVE

The primary objective of the manufacturer is compliance with the regulations outlined in the previous section.

Prior to marketing in the USA, all unlicensed transmitters and transceivers require certification. Receive-only devices operating between 30 MHz and 960 MHz are subject to either certification or a manufacturer’s declaration of conformity, with all other receive-only devices exempt from the technical requirements.

Prior to marketing in Canada, Class I transmitters, receivers and transceivers require certification. Class II devices are required to meet the appropriate technical requirements but are exempt from certification requirements.

Certification is a procedure where the manufacturer submits test data and technical information to a certification body and receives a certificate or grant of equipment authorization upon successful completion of the certification body’s review of the submitted documents. Once the equipment authorization has been obtained, the label indicating compliance must be attached to all identical units, which are subsequently

manufactured.

Maintenance of compliance is the responsibility of the manufacturer. Any modification of the product which may result in increased emissions should be checked to ensure compliance has been maintained (i.e., printed circuit board layout changes, different line filter, different power supply, harnessing or I/O cable changes, etc.).

STATEMENT OF COMPLIANCE

The tested sample of Fitbit, Inc. model FB501 complied with the requirements of the following regulations:

Industry Canada RSS-Gen Issue 3
RSS 210 Issue 8 “Low-power Licence-exempt Radiocommunication Devices (All Frequency Bands): Category I Equipment”
FCC Part 15 Subpart C

Maintenance of compliance is the responsibility of the manufacturer. Any modifications to the product should be assessed to determine their potential impact on the compliance status of the device with respect to the standards detailed in this test report.

The test results recorded herein are based on a single type test of Fitbit, Inc. model FB501 and therefore apply only to the tested sample. The sample was selected and prepared by Arndt Hufenbach of Fitbit, Inc.

DEVIATIONS FROM THE STANDARDS

No deviations were made from the published requirements listed in the scope of this report.

TEST RESULTS SUMMARY**DIGITAL TRANSMISSION SYSTEMS (2400 – 2483.5MHz)**

FCC Rule Part	RSS Rule Part	Description	Measured Value / Comments	Limit / Requirement	Result
15.247(a)	RSS 210 A8.2	Digital Modulation	Systems uses DSSS techniques	System must utilize a digital transmission technology	Complies
15.247 (a) (2)	RSS 210 A8.2 (1)	6dB Bandwidth	707 kHz	>500kHz	Complies
15.247 (b) (3)	RSS 210 A8.2 (4)	Output Power (multipoint systems)	4.3 dBm (0.0027 Watts) EIRP = 0.002 W <small>Note 1</small>	1Watt, EIRP limited to 4 Watts.	Complies
15.247(d)	RSS 210 A8.2 (2)	Power Spectral Density	-1.8 dBm/10kHz	8dBm/3kHz	Complies
15.247(c)	RSS 210 A8.5	Antenna Port Spurious Emissions 30MHz – 25 GHz	all below -20dBc limit	< -20dBc	Complies
15.247(c) / 15.209	RSS 210 A8.5	Radiated Spurious Emissions 30MHz – 25 GHz	53.6 dB μ V/m @ 19214.2 MHz (-0.4 dB)	15.207 in restricted bands, all others < -20dBc	Complies
Note 1: EIRP calculated using antenna gain of -2.22 dBi for the highest EIRP system.					

GENERAL REQUIREMENTS APPLICABLE TO ALL BANDS

FCC Rule Part	RSS Rule part	Description	Measured Value / Comments	Limit / Requirement	Result (margin)
15.203	-	RF Connector	Antenna is internal and integral	Unique or integral antenna required	Complies
15.207	RSS GEN Table 4	AC Conducted Emissions	49.3 dB μ V @ 0.157 MHz (-16.3 dB)	Refer to page 17	Complies
15.109	RSS GEN 7.2.3 Table 1	Receiver spurious emissions	N/A – receiver tunes above 960MHz		
15.247 (b) (5) / 15.407 (f)	RSS 102	RF Exposure Requirements	Refer to SAR Exclusion calculations in separate exhibit, RSS 102 declaration and User Manual statements.	Refer to OET 65, FCC Part 1 and RSS 102	Complies
-	RSP 100 RSS GEN 7.1.3	User Manual	-	Statement required regarding non-interference	Complies
-	RSP 100 RSS GEN 7.1.2	User Manual	-	Statement for products with detachable antenna	N/A
-	RSP 100 RSS GEN 4.6.1	99% Bandwidth	1.045 MHz	Information only	N/A

MEASUREMENT UNCERTAINTIES

ISO/IEC 17025 requires that an estimate of the measurement uncertainties associated with the emissions test results be included in the report. The measurement uncertainties given below are based on a 95% confidence level and were calculated in accordance with UKAS document LAB 34.

Measurement Type	Measurement Unit	Frequency Range	Expanded Uncertainty
RF power, conducted (power meter)	dBm	25 to 7000 MHz	± 0.52 dB
RF power, conducted (Spectrum analyzer)	dBm	25 to 7000 MHz	± 0.7 dB
Conducted emission of transmitter	dBm	25 to 26500 MHz	± 0.7 dB
Conducted emission of receiver	dBm	25 to 26500 MHz	± 0.7 dB
Radiated emission (substitution method)	dBm	25 to 26500 MHz	± 2.5 dB
Radiated emission (field strength)	dB μ V/m	25 to 1000 MHz	± 3.6 dB
		1000 to 40000 MHz	± 6.0 dB
Conducted Emissions (AC Power)	dB μ V	0.15 to 30 MHz	± 2.4 dB

EQUIPMENT UNDER TEST (EUT) DETAILS**GENERAL**

The Fitbit, Inc. model FB501 is a wearable fitness tracker. The EUT was treated as handheld equipment during testing to simulate the end-user environment. The EUT is powered via a rechargeable Li battery.

The sample was received on July 7, 2014 and tested on July 7, 29 and 30, 2014. The EUT consisted of the following component(s):

Company	Model	Description	Serial Number	FCC ID
Fitbit	FB501	Fitness tracker	1 (radiated sample)	XRAFB501
Fitbit	FB501	Fitness tracker	prototype (RF conducted sample)	XRAFB501

OTHER EUT DETAILS

The following EUT details should be noted:

BT 4.0 (Basic/EDR/LE)

USB transfer data

ANTENNA SYSTEM

Internal antenna, -2.22dBi

ENCLOSURE

The EUT enclosure is primarily constructed of rubberized plastic. It measures approximately 3.5 cm wide by 1.2 cm deep by 3.2 cm high.

MODIFICATIONS

No modifications were made to the EUT during the time the product was at NTS Silicon Valley.

SUPPORT EQUIPMENT

The following equipment was used as local support equipment for testing:

Company	Model	Description	Serial Number	FCC ID
Lenovo	T430	Laptop Computer	A2113440	N/A
Lenovo	42T4418	AC/DC Adapter	11S42T4418Z1ZGW G25C49K	N/A

The following equipment was used as remote support equipment for testing:

Company	Model	Description	Serial Number	FCC ID
Cisco	SG100D-08	8port Ethernet Switch	DNI7120EB1	N/A
Gateway	25WT3	Laptop Computer	NXY47AA0034160B3 BE3400	N/A
Chicony	A13-040N3A	AC/DC Adapter	F254111411056692	N/A

EUT INTERFACE PORTS

The I/O cabling configuration during testing was as follows:

Port	Connected To	Cable(s)		
		Description	Shielded or Unshielded	Length(m)
USB/Charge	Lenovo Laptop	Multiconductor	Shielded	0.96

Additional on Support Equipment

Port	Connected To	Cable(s)		
		Description	Shielded or Unshielded	Length(m)
Lenovo Laptop - Ethernet	Remote Switch	CAT5	Unshielded	10
Lenovo Laptop - DC In	AC/DC Adapter	Multiconductor	Shielded	1.5
Lenovo AC/DC Adapter	AC Mains	2wire	Unshielded	1
Remote Switch	Remote Gateway Laptop	CAT5	Unshielded	2
Gateway Laptop - DC In	AC/DC Adapter	Multiconductor	Shielded	1.5
Chicony AC/DC Adapter	AC Mains	2wire	Unshielded	1

EUT OPERATION

Unless otherwise noted, the EUT was configured for continuous transmission at the maximum output power. The modulation used is noted for each test.

TEST SITE**GENERAL INFORMATION**

Final test measurements were taken at the test sites listed below. Pursuant to section 2.948 of the FCC's Rules and section 3.3 of RSP-100, construction, calibration, and equipment data has been filed with the Commission and with industry Canada.

Site	Designation / Registration Numbers		Location
	FCC	Canada	
Chamber 3	US0027	2845B-3	41039 Boyce Road Fremont, CA 94538-2435
Chamber 5	US0027	2845B-5	
Chamber 7	US0027	2845B-7	

ANSI C63.4 recommends that ambient noise at the test site be at least 6 dB below the allowable limits. Ambient levels are below this requirement. The test site(s) contain separate areas for radiated and conducted emissions testing. Considerable engineering effort has been expended to ensure that the facilities conform to all pertinent requirements of ANSI C63.4.

CONDUCTED EMISSIONS CONSIDERATIONS

Conducted emissions testing is performed in conformance with ANSI C63.10. Measurements are made with the EUT connected to the public power network through a nominal, standardized RF impedance, which is provided by a line impedance stabilization network, known as a LISN. A LISN is inserted in series with each current-carrying conductor in the EUT power cord.

RADIATED EMISSIONS CONSIDERATIONS

The FCC has determined that radiation measurements made in a shielded enclosure are not suitable for determining levels of radiated emissions. Radiated measurements are performed in an open field environment or in a semi-anechoic chamber. The test sites are maintained free of conductive objects within the CISPR defined elliptical area incorporated in ANSI C63.4 guidelines and meet the Normalized Site Attenuation (NSA) requirements of ANSI C63.4.

MEASUREMENT INSTRUMENTATION

RECEIVER SYSTEM

An EMI receiver as specified in CISPR 16-1-1 is used for emissions measurements. The receivers used can measure over the frequency range of 9 kHz up to 2000 MHz. These receivers allow both ease of measurement and high accuracy to be achieved. The receivers have Peak, Average, and CISPR (Quasi-peak) detectors built into their design so no external adapters are necessary. The receiver automatically sets the required bandwidth for the CISPR detector used during measurements. If the repetition frequency of the signal being measured is below 20Hz, peak measurements are made in lieu of Quasi-Peak measurements.

For measurements above the frequency range of the receivers, a spectrum analyzer is utilized because it provides visibility of the entire spectrum along with the precision and versatility required to support engineering analysis. Average measurements above 1000MHz are performed on the spectrum analyzer using the linear-average method with a resolution bandwidth of 1 MHz and a video bandwidth of 10 Hz, unless the signal is pulsed in which case the average (or video) bandwidth of the measuring instrument is reduced to onset of pulse desensitization and then increased.

INSTRUMENT CONTROL COMPUTER

The receivers utilize either a Rohde & Schwarz EZM Spectrum Monitor/Controller or contain an internal Spectrum Monitor/Controller to view and convert the receiver measurements to the field strength at an antenna or voltage developed at the LISN measurement port, which is then compared directly with the appropriate specification limit. This provides faster, more accurate readings by performing the conversions described under Sample Calculations within the Test Procedures section of this report. Results are printed in a graphic and/or tabular format, as appropriate. A personal computer is used to record all measurements made with the receivers.

The Spectrum Monitor provides a visual display of the signal being measured. In addition, the controller or a personal computer run automated data collection programs which control the receivers. This provides added accuracy since all site correction factors, such as cable loss and antenna factors are added automatically.

LINE IMPEDANCE STABILIZATION NETWORK (LISN)

Line conducted measurements utilize a fifty microhenry Line Impedance Stabilization Network as the monitoring point. The LISN used also contains a 250 uH CISPR adapter. This network provides for calibrated radio frequency noise measurements by the design of the internal low pass and high pass filters on the EUT and measurement ports, respectively.

FILTERS/ATTENUATORS

External filters and precision attenuators are often connected between the receiving antenna or LISN and the receiver. This eliminates saturation effects and non-linear operation due to high amplitude transient events.

ANTENNAS

A loop antenna is used below 30 MHz. For the measurement range 30 MHz to 1000 MHz either a combination of a biconical antenna and a log periodic or a bi-log antenna is used. Above 1000 MHz, horn antennas are used. The antenna calibration factors to convert the received voltage to an electric field strength are included with appropriate cable loss and amplifier gain factors to determine an overall site factor, which is then programmed into the test receivers or incorporated into the test software.

ANTENNA MAST AND EQUIPMENT TURNTABLE

The antennas used to measure the radiated electric field strength are mounted on a non-conductive antenna mast equipped with a motor-drive to vary the antenna height. Measurements below 30 MHz are made with the loop antenna at a fixed height of 1m above the ground plane.

ANSI C63.10 specifies that the test height above ground for table mounted devices shall be 80 centimeters. Floor mounted equipment shall be placed on the ground plane if the device is normally used on a conductive floor or separated from the ground plane by insulating material from 3 to 12 mm if the device is normally used on a non-conductive floor as specified in ANSI C63.4. During radiated measurements, the EUT is positioned on a motorized turntable in conformance with this requirement.

INSTRUMENT CALIBRATION

All test equipment is regularly checked to ensure that performance is maintained in accordance with the manufacturer's specifications. All antennas are calibrated at regular intervals with respect to tuned half-wave dipoles. An exhibit of this report contains the list of test equipment used and calibration information.

TEST PROCEDURES

EUT AND CABLE PLACEMENT

The regulations require that interconnecting cables be connected to the available ports of the unit and that the placement of the unit and the attached cables simulate the worst case orientation that can be expected from a typical installation, so far as practicable. To this end, the position of the unit and associated cabling is varied within the guidelines of ANSI C63.10, and the worst-case orientation is used for final measurements.

CONDUCTED EMISSIONS

Conducted emissions are measured at the plug end of the power cord supplied with the EUT. Excess power cord length is wrapped in a bundle between 30 and 40 centimeters in length near the center of the cord. Preliminary measurements are made to determine the highest amplitude emission relative to the specification limit for all the modes of operation. Placement of system components and varying of cable positions are performed in each mode. A final peak mode scan is then performed in the position and mode for which the highest emission was noted on all current carrying conductors of the power cord.

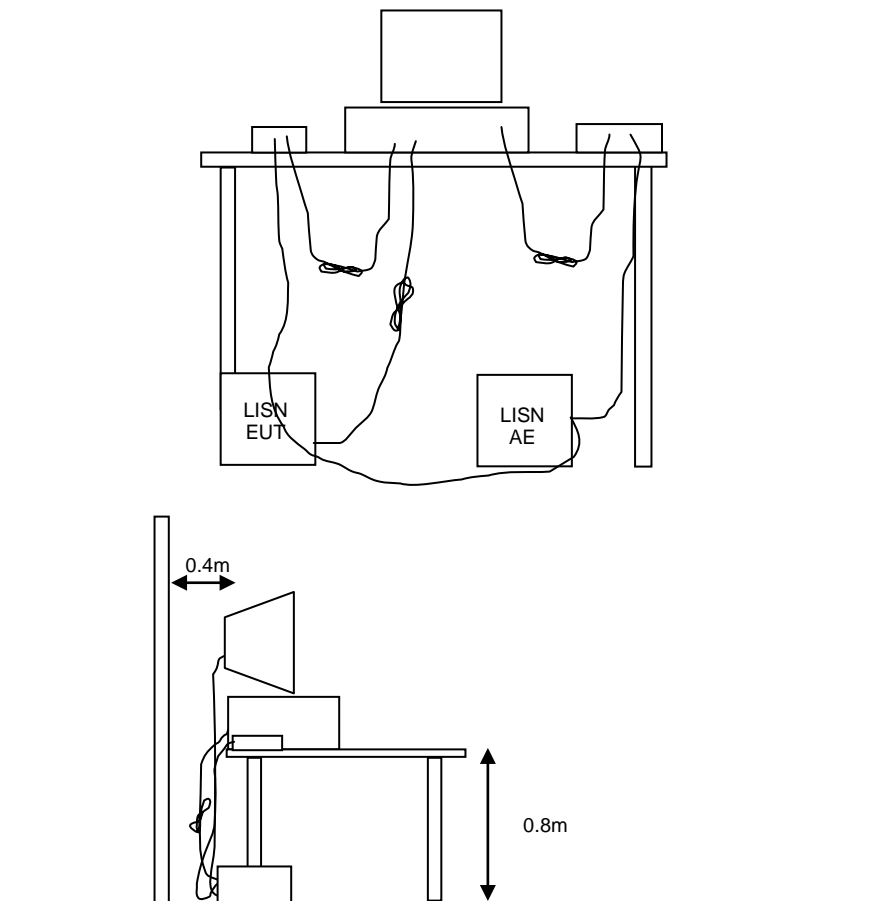

Figure 1 Typical Conducted Emissions Test Configuration

RADIATED EMISSIONS

A preliminary scan of the radiated emissions is performed in which all significant EUT frequencies are identified with the system in a nominal configuration. At least two scans are performed, one scan for each antenna polarization (horizontal and vertical; loop parallel and perpendicular to the EUT). During the preliminary scans, the EUT is rotated through 360°, the antenna height is varied (for measurements above 30 MHz) and cable positions are varied to determine the highest emission relative to the limit. Preliminary scans may be performed in a fully anechoic chamber for the purposes of identifying the frequencies of the highest emissions from the EUT.

A speaker is provided in the receiver to aid in discriminating between EUT and ambient emissions. Other methods used during the preliminary scan for EUT emissions involve scanning with near field magnetic loops, monitoring I/O cables with RF current clamps, and cycling power to the EUT.

Final maximization is a phase in which the highest amplitude emissions identified in the spectral search are viewed while the EUT azimuth angle is varied from 0 to 360 degrees relative to the receiving antenna. The azimuth, which results in the highest emission is then maintained while varying the antenna height from one to four meters (for measurements above 30 MHz, measurements below 30 MHz are made with the loop antenna at a fixed height of 1m). The result is the identification of the highest amplitude for each of the highest peaks. Each recorded level is corrected in the receiver using appropriate factors for cables, connectors, antennas, and preamplifier gain.

When testing above 18 GHz, the receive antenna is located at 1meter from the EUT and the antenna height is restricted to a maximum of 2.5 meters.

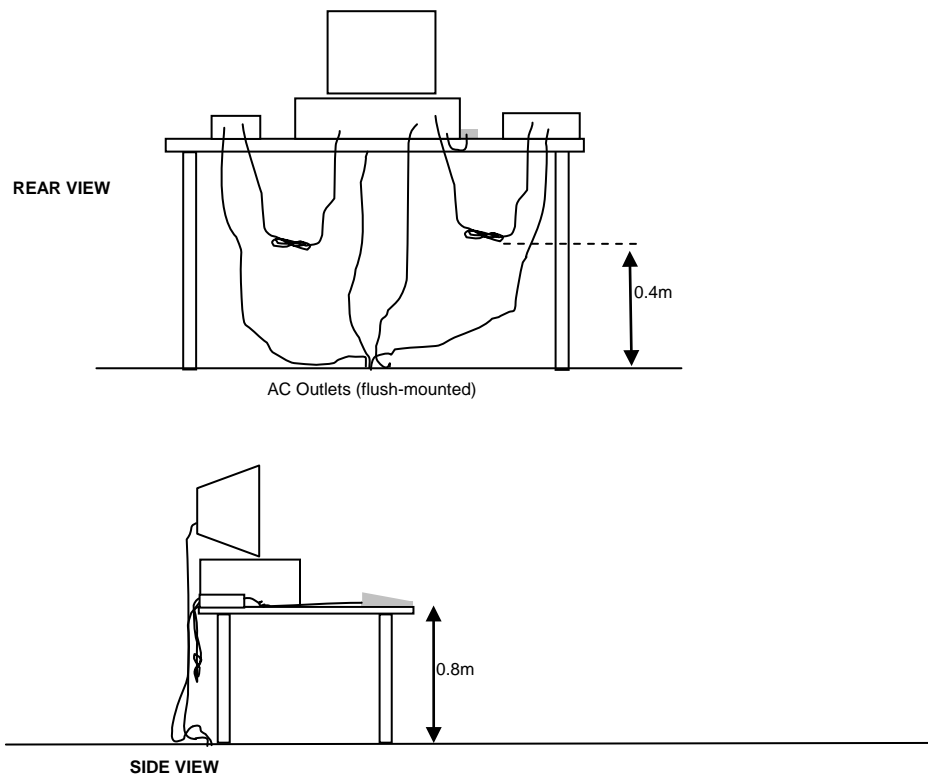

Typical Test Configuration for Radiated Field Strength Measurements

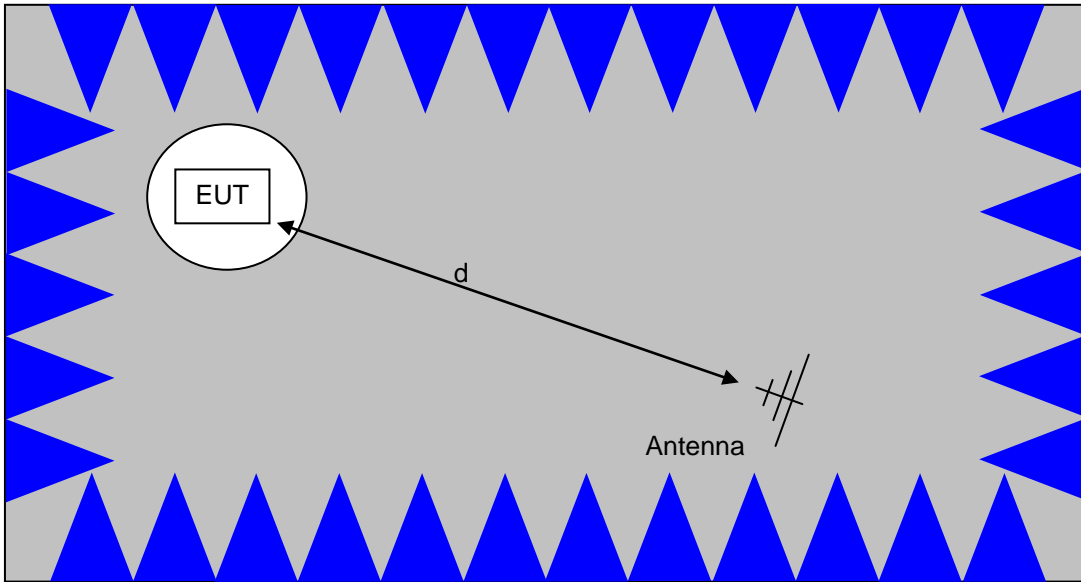

The anechoic materials on the walls and ceiling ensure compliance with the normalized site attenuation requirements of CISPR 16 / CISPR 22 / ANSI C63.4 for an alternate test site at the measurement distances used.

Floor-standing equipment is placed on the floor with insulating supports between the unit and the ground plane.

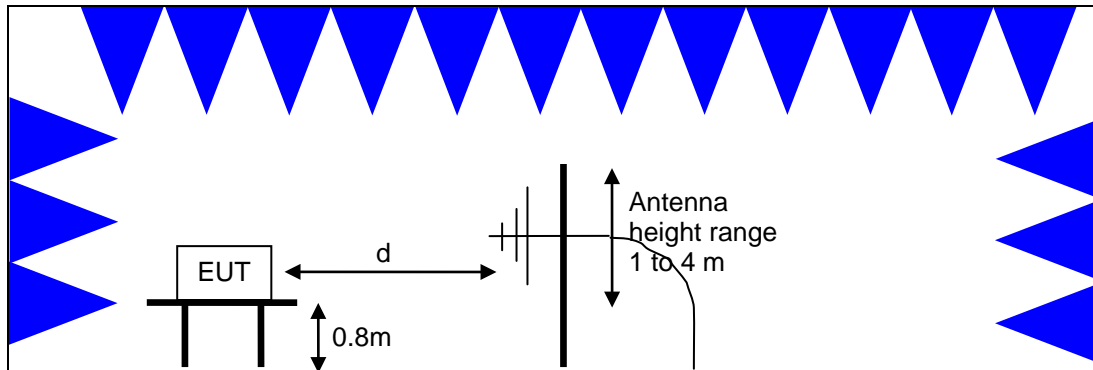

Test Configuration for Radiated Field Strength Measurements
Semi-Anechoic Chamber, Plan and Side Views

CONDUCTED EMISSIONS FROM ANTENNA PORT

Direct measurements of power, bandwidth and power spectral density are performed, where possible, with the antenna port of the EUT connected to either the power meter or spectrum analyzer via a suitable attenuator and/or filter. These are used to ensure that the front end of the measurement instrument is not overloaded by the fundamental transmission.

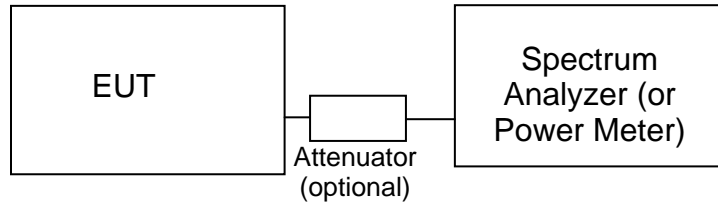
**Test Configuration for Antenna Port Measurements**

Measurement bandwidths (video and resolution) are set in accordance with the relevant standards and NTS Silicon Valley's test procedures for the type of radio being tested. When power measurements are made using a resolution bandwidth less than the signal bandwidth the power is calculated by summing the power across the signal bandwidth using either the analyzer channel power function or by capturing the trace data and calculating the power using software. In both cases the summed power is corrected to account for the equivalent noise bandwidth (ENBW) of the resolution bandwidth used.

If power averaging is used (typically for certain digital modulation techniques), the EUT is configured to transmit continuously. Power averaging is performed using either the built-in function of the analyzer or, if the analyzer does not feature power averaging, using external software. In both cases the average power is calculated over a number of sweeps (typically 100). When the EUT cannot be configured to continuously transmit then either the analyzer is configured to perform a gated sweep to ensure that the power is averaged over periods that the device is transmitting or power averaging is disabled and a max-hold feature is used.

If a power meter is used to make output power measurements the sensor head type (peak or average) is stated in the test data table.

BANDWIDTH MEASUREMENTS

The 6dB, 20dB, 26dB and/or 99% signal bandwidth are measured using the bandwidths recommended by ANSI C63.10 and RSS GEN.

SPECIFICATION LIMITS AND SAMPLE CALCULATIONS

The limits for conducted emissions are given in units of microvolts, and the limits for radiated emissions are given in units of microvolts per meter at a specified test distance. Data is measured in the logarithmic form of decibels relative to one microvolt, or dB microvolts (dBuV). For radiated emissions, the measured data is converted to the field strength at the antenna in dB microvolts per meter (dBuV/m). The results are then converted to the linear forms of uV and uV/m for comparison to published specifications.

For reference, converting the specification limits from linear to decibel form is accomplished by taking the base ten logarithm, then multiplying by 20. These limits in both linear and logarithmic form are as follows:

CONDUCTED EMISSIONS SPECIFICATION LIMITS: FCC 15.207; FCC 15.107(a), RSS GEN

The table below shows the limits for the emissions on the AC power line from an intentional radiator and a receiver.

Frequency (MHz)	Average Limit (dBuV)	Quasi Peak Limit (dBuV)
0.150 to 0.500	Linear decrease on logarithmic frequency axis between 56.0 and 46.0	Linear decrease on logarithmic frequency axis between 66.0 and 56.0
0.500 to 5.000	46.0	56.0
5.000 to 30.000	50.0	60.0

GENERAL TRANSMITTER RADIATED EMISSIONS SPECIFICATION LIMITS

The table below shows the limits for the spurious emissions from transmitters that fall in restricted bands¹ (with the exception of transmitters operating under FCC Part 15 Subpart D and RSS 210 Annex 9), the limits for all emissions from a low power device operating under the general rules of RSS 310 (tables 3 and 4), RSS 210 (table 2) and FCC Part 15 Subpart C section 15.209.

Frequency Range (MHz)	Limit (uV/m)	Limit (dBuV/m @ 3m)
0.009-0.490	$2400/F_{\text{KHz}} @ 300\text{m}$	$67.6-20*\log_{10}(F_{\text{KHz}}) @ 300\text{m}$
0.490-1.705	$24000/F_{\text{KHz}} @ 30\text{m}$	$87.6-20*\log_{10}(F_{\text{KHz}}) @ 30\text{m}$
1.705 to 30	30 @ 30m	29.5 @ 30m
30 to 88	100 @ 3m	40 @ 3m
88 to 216	150 @ 3m	43.5 @ 3m
216 to 960	200 @ 3m	46.0 @ 3m
Above 960	500 @ 3m	54.0 @ 3m

¹ The restricted bands are detailed in FCC 15.203, RSS 210 Table 1 and RSS 310 Table 2

OUTPUT POWER LIMITS – DIGITAL TRANSMISSION SYSTEMS

The table below shows the limits for output power and output power density. Where the signal bandwidth is less than 20 MHz the maximum output power is reduced to the power spectral density limit plus 10 times the log of the bandwidth (in MHz).

Operating Frequency (MHz)	Output Power	Power Spectral Density
902 – 928	1 Watt (30 dBm)	8 dBm/3kHz
2400 – 2483.5	1 Watt (30 dBm)	8 dBm/3kHz
5725 – 5850	1 Watt (30 dBm)	8 dBm/3kHz

The maximum permitted output power is reduced by 1dB for every dB the antenna gain exceeds 6dBi. Fixed point-to-point applications using the 5725 – 5850 MHz band are not subject to this restriction.

TRANSMIT MODE SPURIOUS RADIATED EMISSIONS LIMITS – FHSS and DTS SYSTEMS

The limits for unwanted (spurious) emissions from the transmitter falling in the restricted bands are those specified in the general limits sections of FCC Part 15 and RSS 210. All other unwanted (spurious) emissions shall be at least 20dB below the level of the highest in-band signal level (30dB if the power is measured using the sample detector/power averaging method).

SAMPLE CALCULATIONS - CONDUCTED EMISSIONS

Receiver readings are compared directly to the conducted emissions specification limit (decibel form) as follows:

$$R_T - S = M$$

where:

R_T = Receiver Reading in dBuV

S = Specification Limit in dBuV

M = Margin to Specification in +/- dB

SAMPLE CALCULATIONS - RADIATED EMISSIONS

Receiver readings are compared directly to the specification limit (decibel form). The receiver internally corrects for cable loss, preamplifier gain, and antenna factor. The calculations are in the reverse direction of the actual signal flow, thus cable loss is added and the amplifier gain is subtracted. The Antenna Factor converts the voltage at the antenna coaxial connector to the field strength at the antenna elements.

A distance factor, when used for electric field measurements above 30MHz, is calculated by using the following formula:

$$F_d = 20 * \text{LOG}_{10} (D_m/D_s)$$

where:

$$F_d = \text{Distance Factor in dB}$$

$$D_m = \text{Measurement Distance in meters}$$

$$D_s = \text{Specification Distance in meters}$$

For electric field measurements below 30MHz the extrapolation factor is either determined by making measurements at multiple distances or a theoretical value is calculated using the formula:

$$F_d = 40 * \text{LOG}_{10} (D_m/D_s)$$

Measurement Distance is the distance at which the measurements were taken and Specification Distance is the distance at which the specification limits are based. The antenna factor converts the voltage at the antenna coaxial connector to the field strength at the antenna elements.

The margin of a given emission peak relative to the limit is calculated as follows:

$$R_c = R_r + F_d$$

and

$$M = R_c - L_s$$

where:

$$R_r = \text{Receiver Reading in dBuV/m}$$

$$F_d = \text{Distance Factor in dB}$$

$$R_c = \text{Corrected Reading in dBuV/m}$$

$$L_s = \text{Specification Limit in dBuV/m}$$

$$M = \text{Margin in dB Relative to Spec}$$

SAMPLE CALCULATIONS - FIELD STRENGTH TO EIRP CONVERSION

Where the radiated electric field strength is expressed in terms of the equivalent isotropic radiated power (eirp), or where a field strength measurement of output power is made in lieu of a direct measurement, the following formula is used to convert between eirp and field strength at a distance of d (meters) from the equipment under test:

$$E = \frac{1000000 \sqrt{30 P}}{d} \quad \text{microvolts per meter}$$

where P is the eirp (Watts)

For a measurement at 3m the conversion from a logarithmic value for field strength (dBuV/m) to an eirp power (dBm) is -95.3dB.

Appendix A Test Equipment Calibration Data

<u>Manufacturer</u>	<u>Description</u>	<u>Model</u>	<u>Asset #</u>	<u>Cal Due</u>
Duty Cycle, 1000 - 18,000 MHz, 11-Jul-14				
Hewlett Packard	SpecAn 9 kHz - 40 GHz, FT (SA40) Blue	8564E (84125C)	1393	5/6/2015
Radiated Emissions, 1000 - 25,000 MHz, 29-Jul-14				
EMCO	Antenna, Horn, 1-18 GHz	3115	786	12/20/2015
Hewlett Packard	SpecAn 9 kHz - 40 GHz, FT (SA40) Blue	8564E (84125C)	1393	5/6/2015
Hewlett Packard	Head (Inc flex cable, (1742,1743) Blue)	84125C	1620	5/6/2015
Hewlett Packard	Microwave Preamplifier, 1-26.5GHz	8449B	1780	11/26/2014
A. H. Systems	Purple System Horn, 18-40GHz	SAS-574, p/n: 2581	2160	7/31/2014
Micro-Tronics	Band Reject Filter, 2400-2500 MHz	BRM50702-02	2238	9/18/2014
Rohde & Schwarz	EMI Test Receiver, 20 Hz-40 GHz	ESIB40 (1088.7490.40)	2493	1/11/2015
Radiated Emissions, 12,000 - 18,000 MHz, 29-Jul-14				
EMCO	Antenna, Horn, 1-18 GHz	3115	786	12/20/2015
Hewlett Packard	High Pass filter, 8.2 GHz	P/N 84300-80039	1156	6/7/2015
Hewlett Packard	SpecAn 9 kHz - 40 GHz, FT (SA40) Blue	8564E (84125C)	1393	5/6/2015
Hewlett Packard	Microwave Preamplifier, 1-26.5GHz	8449B	1780	11/26/2014
Radio Antenna Port (Power and Spurious Emissions), 30-Jul-14				
Hewlett Packard	SpecAn 9 KHz-26.5 GHz, Non-Program	8563E	284	2/26/2015
Rohde & Schwarz	Power Meter, Single Channel	NRVS	1422	1/24/2015
Rohde & Schwarz	Power Sensor 100 uW - 2 Watts use with 20dB attenuator sn:1031.6959.00 only	NRV-Z32	1423	9/17/2014
Conducted Emissions - AC Power Ports, 07-Jul-14				
<u>Manufacturer</u>	<u>Description</u>	<u>Model</u>	<u>Asset #</u>	<u>Cal Due</u>
EMCO	LISN, 10 kHz-100 MHz, 25A	3825/2	1292	2/13/2015
Rohde & Schwarz	Pulse Limiter	ESH3 Z2	1594	5/15/2015
Rohde & Schwarz	EMI Test Receiver, 20 Hz-7 GHz	ESIB7	1756	6/14/2015
FCC	Decoupling Network	F-203I-DCN-23mm	2457	N/A

Appendix B Test Data

T95507 Pages 24 – 47

T95502 Pages 48 – 51



EMC Test Data

Client:	Fitbit, Inc.	Job Number:	J95447
Product:	FB501 (Proton)	T-Log Number:	T95507
		Project Manager:	Deepa Shetty
Contact:	Arndt Hufenbach	Project Coordinator:	Irene Rademacher
Emissions Standard(s):	FCC 15.247/RSS-210/LP 00002	Class:	-
Immunity Standard(s):	-	Environment:	-

EMC Test Data

For The

Fitbit, Inc.

Product

FB501 (Proton)

Date of Last Test: 7/29/2014



EMC Test Data

Client: Fitbit, Inc.	Job Number: J95447
Model: FB501 (Proton)	T-Log Number: T95507
	Project Manager: Deepa Shetty
Contact: Arndt Hufenbach	Project Coordinator: Irene Rademacher
Standard: FCC 15.247/RSS-210/LP 00002	Class: N/A

RSS 210 and FCC 15.247 (DTS) Antenna Port Measurements Power, PSD, Bandwidth and Spurious Emissions

Test Specific Details

Objective: The objective of this test session is to perform final qualification testing of the EUT with respect to the specification listed above.

Date of Test: 7/30/2014
 Test Engineer: John Caizzi
 Test Location: Lab 6

Config. Used: Conducted
 Config Change: -
 EUT Voltage: Battery

General Test Configuration

The EUT was connected to the spectrum analyzer or power meter via a suitable attenuator. All measurements were made on a single chain.

All measurements have been corrected to allow for the external attenuators used.

Ambient Conditions: Temperature: 18-20 °C
 Rel. Humidity: 30-35 %

Summary of Results

Run #	Pwr setting	Avg Pwr	Test Performed	Limit	Pass / Fail	Result / Margin
1	0F		Output Power	15.247(b)	Pass	4.3 dBm (0.0027W)
2			Power spectral Density (PSD)	15.247(d)	Pass	-1.8 dBm/10kHz
3			Minimum 6dB Bandwidth	15.247(a)	Pass	707 kHz
3			99% Bandwidth	RSS GEN	-	1.045 MHz
4			Spurious emissions	15.247(b)	Pass	all below -20dBc limit

Modifications Made During Testing

No modifications were made to the EUT during testing

Deviations From The Standard

No deviations were made from the requirements of the standard.

Procedure Comments:

Measurements performed in accordance with FCC KDB 558074



EMC Test Data

Client: Fitbit, Inc.	Job Number: J95447
Model: FB501 (Proton)	T-Log Number: T95507
	Project Manager: Deepa Shetty
Contact: Arndt Hufenbach	Project Coordinator: Irene Rademacher
Standard: FCC 15.247/RSS-210/LP 00002	Class: N/A

Mode	Data Rate	Duty Cycle (x)	Constant DC?	T (ms)	Pwr Cor Factor*	Lin Volt Cor Factor**	Min VBW for FS (Hz)
LE	1 Mb/s	0.65	Yes	0.408	1.87	3.73	2451

Sample Notes

Sample S/N: 1
 Driver: F13.1



EMC Test Data

Client: Fitbit, Inc.	Job Number: J95447
Model: FB501 (Proton)	T-Log Number: T95507
	Project Manager: Deepa Shetty
Contact: Arndt Hufenbach	Project Coordinator: Irene Rademacher
Standard: FCC 15.247/RSS-210/LP 00002	Class: N/A

Run #1: Output Power

Mode: LE

Power Setting ²	Frequency (MHz)	Output Power		Antenna Gain (dBi)	Result	EIRP		Output Power	
		(dBm) ¹	mW			dBm	W	(dBm) ³	mW
0F	2402	4.3	2.7	-2.22	Pass	2.1	0.002		
	2440	4.0	2.5	-2.22	Pass	1.8	0.002		
	2480	4.1	2.6	-2.22	Pass	1.9	0.002		

- Note 1: Output power measured using a peak power meter, spurious limit is -20dBc.
- Note 2: Power setting - the software power setting used during testing, included for reference only.

Client: Fitbit, Inc.	Job Number: J95447
Model: FB501 (Proton)	T-Log Number: T95507
Contact: Arndt Hufenbach	Project Manager: Deepa Shetty
Standard: FCC 15.247/RSS-210/LP 00002	Project Coordinator: Irene Rademacher
	Class: N/A

Run #2: Power Spectral Density

Mode: LE

Power Setting	Frequency (MHz)	PSD	Limit dBm/3kHz	Result
		(dBm/10kHz) <small>Note 1</small>		
0F	2402	-2.3	8.0	Pass
	2440	-2.2	8.0	Pass
	2480	-1.8	8.0	Pass

Note 1: Test performed per method PKSPD, in KDB 558074. Power spectral density measured using: $3\text{kHz} \leq \text{RBW} \leq 100\text{kHz}$, $\text{VBW}=3*\text{RBW}$, peak detector, span = $1.5*\text{DTS BW}$, auto sweep time, max hold.

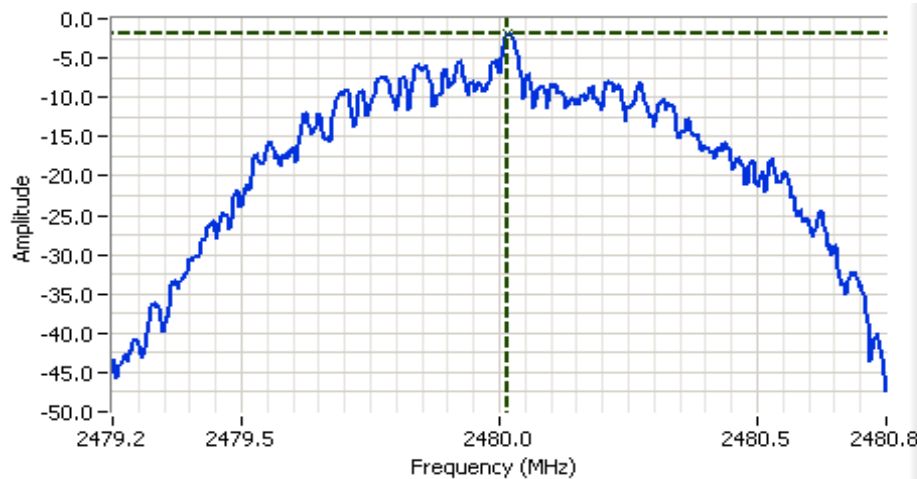

Analyzer Settings

HP8563E
 CF: 2480.000 MHz
 SPAN: 1.500 MHz
 RB: 10.0 kHz
 VB: 30.0 kHz
 Detector: POS
 Attn: 10 DB
 RL Offset: 1.0 DB
 Sweep Time: 50.0ms
 Ref Lvl: 0.0 DBM

Comments

LE
 PSD: -1.83 dBm/10 kHz

Cursor 1 2480.0175 -1.83

0.0000 0.00

Client: Fitbit, Inc.	Job Number: J95447
Model: FB501 (Proton)	T-Log Number: T95507
Contact: Arndt Hufenbach	Project Manager: Deepa Shetty
Standard: FCC 15.247/RSS-210/LP 00002	Project Coordinator: Irene Rademacher
	Class: N/A

Run #3: Signal Bandwidth

Mode: LE

Power Setting	Frequency (MHz)	Bandwidth (kHz)		RBW Setting (kHz)	
		6dB	99%	6dB	99%
0F	2402	713	1045	100	30
	2440	707	1038		
	2480	713	1038		

Note 1: DTS BW: RBW=100kHz, VBW ≥ 3*RBW, peak detector, max hold, auto sweep time.
 99% BW: RBW=1-5% of of 99%BW, VBW ≥ 3*RBW, peak detector, max hold, auto sweep time.

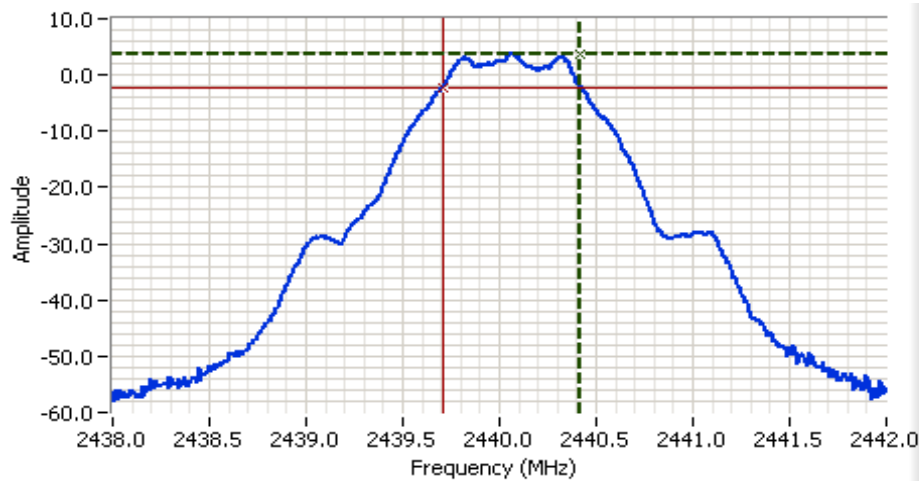

Analyzer Settings

HP8563E
 CF: 2440.000 MHz
 SPAN: 4.000 MHz
 RB: 100 kHz
 VB: 300 kHz
 Detector: POS
 Attn: 20 DB
 RL Offset: 1.0 DB
 Sweep Time: 50.0ms
 Ref Lvl: 10.0 DBM

Comments

LE
 6dB BW: 707 kHz

Cursor 1	2440.4200	3.83	Delta Freq.	707 kHz
Cursor 2	2439.7133	-2.17	Delta Amplitude	6.00

Client: Fitbit, Inc.	Job Number: J95447
Model: FB501 (Proton)	T-Log Number: T95507
Contact: Arndt Hufenbach	Project Manager: Deepa Shetty
Standard: FCC 15.247/RSS-210/LP 00002	Project Coordinator: Irene Rademacher
	Class: N/A

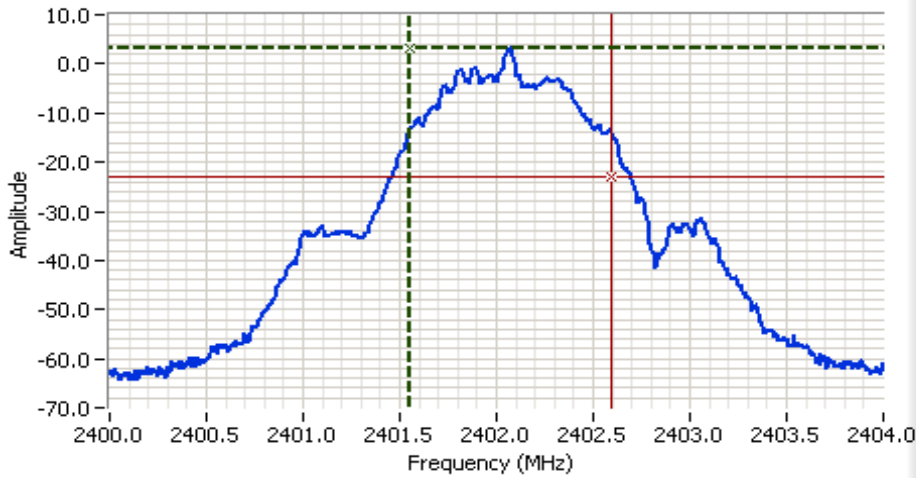

Analyzer Settings

HP8563E
 CF: 2402.000 MHz
 SPAN: 4.000 MHz
 RB: 30.0 kHz
 VB: 100 kHz
 Detector: POS
 Attn: 20 DB
 RL Offset: 1.0 DB
 Sweep Time: 50.0ms
 Ref Lvl: 10.0 DBM

Comments

LE
 99% power BW: 1.045 MHz

Cursor 1	2401.5507	3.00		Delta Freq.	1.045
Cursor 2	2402.5957	-23.00		Delta Amplitude	26.00

Client: Fitbit, Inc.	Job Number: J95447
Model: FB501 (Proton)	T-Log Number: T95507
Contact: Arndt Hufenbach	Project Manager: Deepa Shetty
Standard: FCC 15.247/RSS-210/LP 00002	Project Coordinator: Irene Rademacher
	Class: N/A

Run #4a: Out of Band Spurious Emissions

Frequency (MHz)	Power Setting	Mode	Limit	Result
2402	0F	LE	-20dBc	Pass
2440				Pass
2480				Pass

Plots for low channel

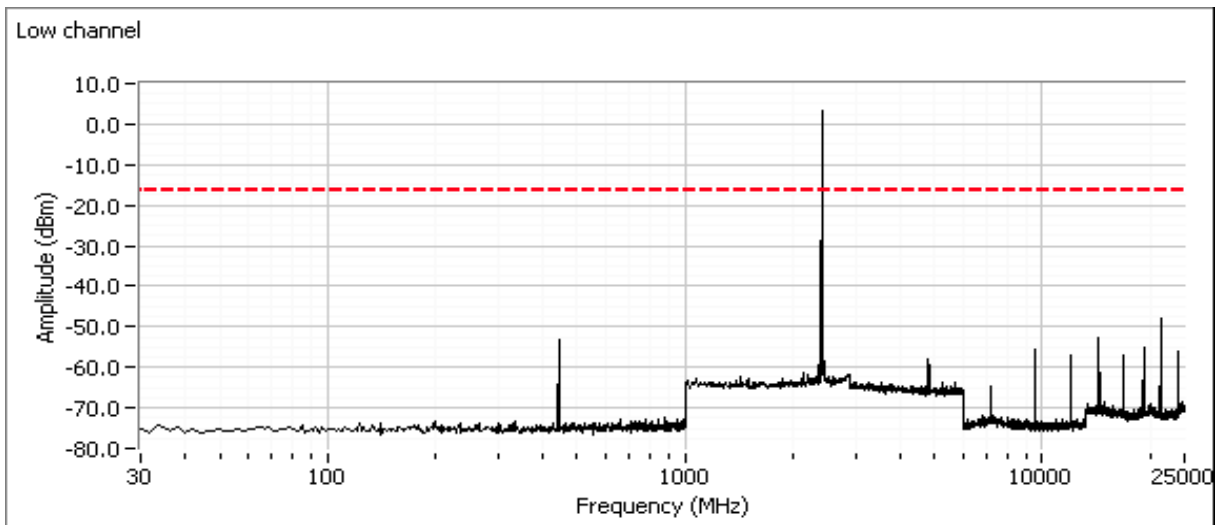

Client: Fitbit, Inc.	Job Number: J95447
Model: FB501 (Proton)	T-Log Number: T95507
Contact: Arndt Hufenbach	Project Manager: Deepa Shetty
Standard: FCC 15.247/RSS-210/LP 00002	Project Coordinator: Irene Rademacher
	Class: N/A

Additional plot showing compliance with -20dBc limit from 2390 MHz to 2400 MHz. Radiated measurements used to show compliance with the limits in the restricted band below 2390 MHz.

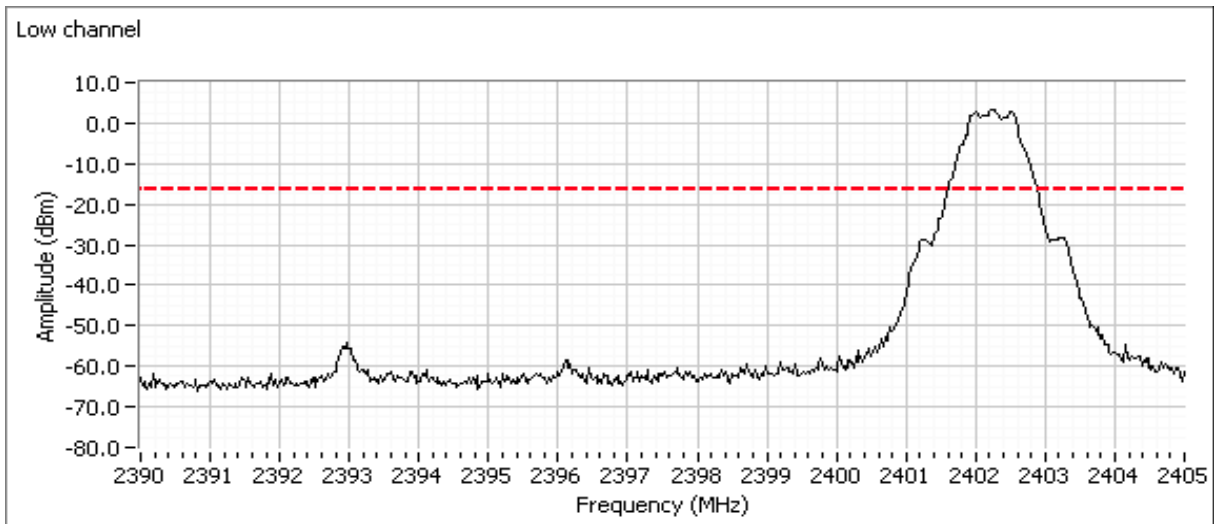

Plot for center channel

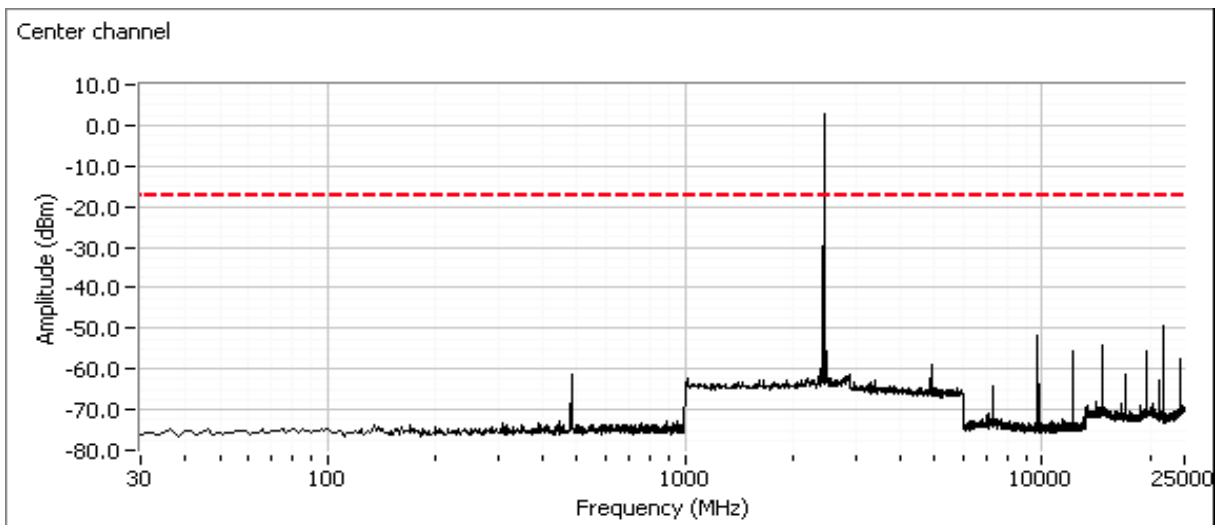

Client: Fitbit, Inc.	Job Number: J95447
Model: FB501 (Proton)	T-Log Number: T95507
	Project Manager: Deepa Shetty
Contact: Arndt Hufenbach	Project Coordinator: Irene Rademacher
Standard: FCC 15.247/RSS-210/LP 00002	Class: N/A

Plot for high channel

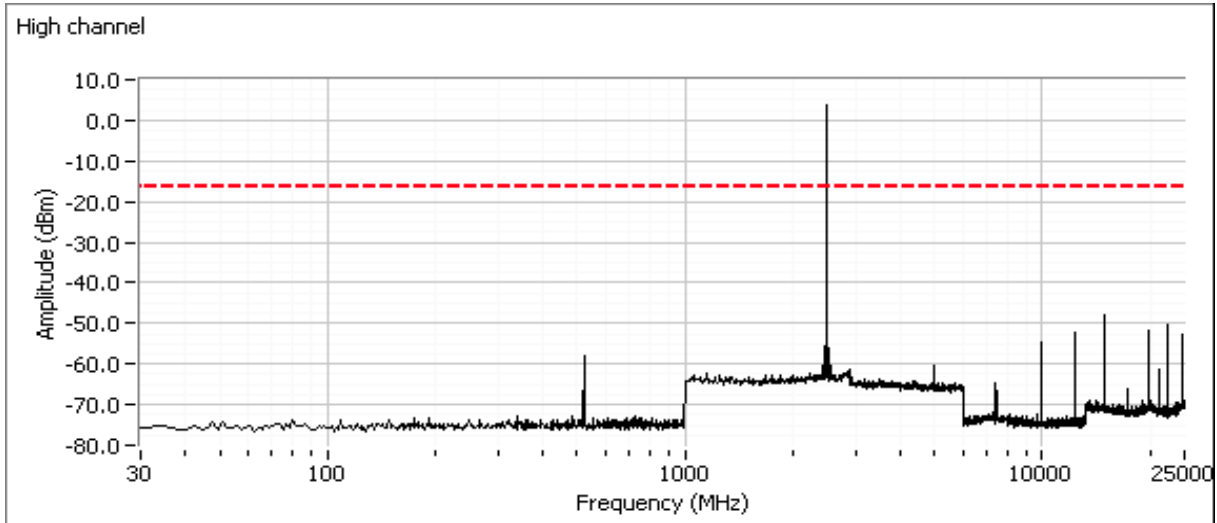



EMC Test Data

Client: Fitbit, Inc.	Job Number: J95447
Model: FB501 (Proton)	T-Log Number: T95507
	Project Manager: Deepa Shetty
Contact: Arndt Hufenbach	Project Coordinator: Irene Rademacher
Standard: FCC 15.247/RSS-210/LP 00002	Class: N/A

RSS 210 and FCC 15.247 (DTS) Radiated Spurious Emissions

Test Specific Details

Objective: The objective of this test session is to perform final qualification testing of the EUT with respect to the specification listed above.

General Test Configuration

The EUT and all local support equipment were located on the turntable for radiated spurious emissions testing.

For radiated emissions testing the measurement antenna was located 3 meters from the EUT, unless otherwise noted.

Ambient Conditions:

Temperature: 22-25 °C
Rel. Humidity: 35-45 %

Summary of Results - Device Operating in the 2400-2483.5 MHz Band

Run #	Mode	Channel	Target Power	Power Setting	Test Performed	Limit	Result / Margin
1	LE - GFSK	2402MHz	0F	0F	Radiated Emissions, 1 - 25 GHz	FCC Part 15.209 / 15.247(c)	53.6 dBµV/m @ 19214.2 MHz (-0.4 dB)
		2441MHz					52.9 dBµV/m @ 19518.3 MHz (-1.1 dB)
		2480MHz					53.5 dBµV/m @ 17349.6 MHz (-0.5 dB)

Modifications Made During Testing

No modifications were made to the EUT during testing

Deviations From The Standard

No deviations were made from the requirements of the standard.

Sample Notes

Sample S/N: 1
Driver: F13.1
Antenna: Internal

Notes

Device is handheld. Determination of worse case orientation was take from the FHSS spurious data.



EMC Test Data

Client: Fitbit, Inc.	Job Number: J95447
Model: FB501 (Proton)	T-Log Number: T95507
	Project Manager: Deepa Shetty
Contact: Arndt Hufenbach	Project Coordinator: Irene Rademacher
Standard: FCC 15.247/RSS-210/LP 00002	Class: N/A

Procedure Comments:

Measurements performed in accordance with FCC KDB 558074

Peak measurements performed with: RBW=1MHz, VBW=3MHz, peak detector, max hold, auto sweep time

Unless otherwise stated/noted, emission has duty cycle $\geq 98\%$ and was measured using RBW=1MHz, VBW=10Hz, peak detector, linear average mode, auto sweep time, max hold.

2.4GHz band reject filter used

Mode	Data Rate	Duty Cycle (x)	Constant DC?	T (ms)	Pwr Cor Factor*	Lin Volt Cor Factor**	Min VBW for FS (Hz)
LE	1 Mb/s	0.65	Yes	0.408	1.87	3.73	2451

Measurement Specific Notes:

Note 1:	Emission in non-restricted band, but limit of 15.209 used.
Note 2:	Emission in non-restricted band, the limit was set 30dB below the level of the fundamental and measured in 100kHz.
Note 3:	Emission has duty cycle $< 98\%$, but constant, average measurement performed: RBW=1MHz, VBW=10Hz, peak detector, linear averaging, auto sweep, trace average 100 traces, measurement corrected by Linear Voltage correction factor



EMC Test Data

Client: Fitbit, Inc.	Job Number: J95447
Model: FB501 (Proton)	T-Log Number: T95507
	Project Manager: Deepa Shetty
Contact: Arndt Hufenbach	Project Coordinator: Irene Rademacher
Standard: FCC 15.247/RSS-210/LP 00002	Class: N/A

Run #1: Radiated Spurious Emissions, 1,000 - 25000 MHz. Operating Mode: LE - GFSK

Date of Test: 07/29/14	Config. Used: 1
Test Engineer: John Caizzi / R. Varelas	Config Change: none
Test Location: Chamber 5	EUT Voltage: 120V / 60Hz

Run #1a: Low Channel 19216

Channel: 2402 MHz Mode: LE
 Tx Chain: Main Data Rate: 1 Mb/s

Frequency	Level	Pol	15.209 / 15.247		Detector	Azimuth	Height	Comments
MHz	dB μ V/m	v/h	Limit	Margin	Pk/QP/Avg	degrees	meters	
19214.200	53.6	H	54.0	-0.4	AVG	161	1.07	Note 3
19214.100	61.2	H	74.0	-12.8	PK	161	1.07	
1325.000	37.2	V	54.0	-16.8	Peak	138	1.5	Measure in run 1b, not radio related.
7205.470	46.9	H	54.0	-7.1	AVG	196	1.15	Note 1, Note 3
7205.400	53.0	H	74.0	-21.0	PK	196	1.15	Note 1
1986.740	30.3	V	54.0	-23.7	AVG	283	1.00	Note 1, not radio related.
1997.540	52.6	V	74.0	-21.4	PK	283	1.00	Note 1, not radio related.
4803.930	40.8	V	54.0	-13.2	AVG	89	1.00	Note 3
4804.480	46.7	V	74.0	-27.3	PK	89	1.00	
12004.670	47.1	V	54.0	-6.9	AVG	132	0.97	Note 1, Note 3
12003.930	55.0	V	74.0	-19.0	PK	132	0.97	
14410.550	52.0	H	54.0	-2.0	AVG	52	1.52	Note 1, Note 3
14410.130	59.1	H	74.0	-14.9	PK	52	1.52	Note 1
16809.750	48.5	H	54.0	-5.5	AVG	52	1.73	Note 1, Note 3
16805.480	56.3	H	74.0	-17.7	PK	52	1.73	Note 1

Client: Fitbit, Inc.	Job Number: J95447
Model: FB501 (Proton)	T-Log Number: T95507
Contact: Arndt Hufenbach	Project Manager: Deepa Shetty
Standard: FCC 15.247/RSS-210/LP 00002	Project Coordinator: Irene Rademacher
	Class: N/A

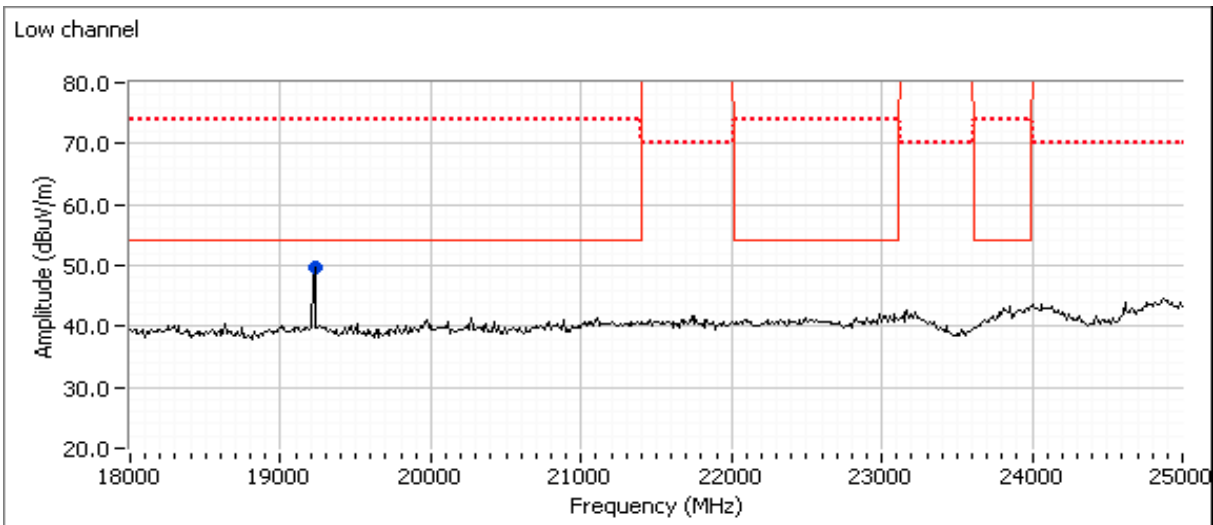
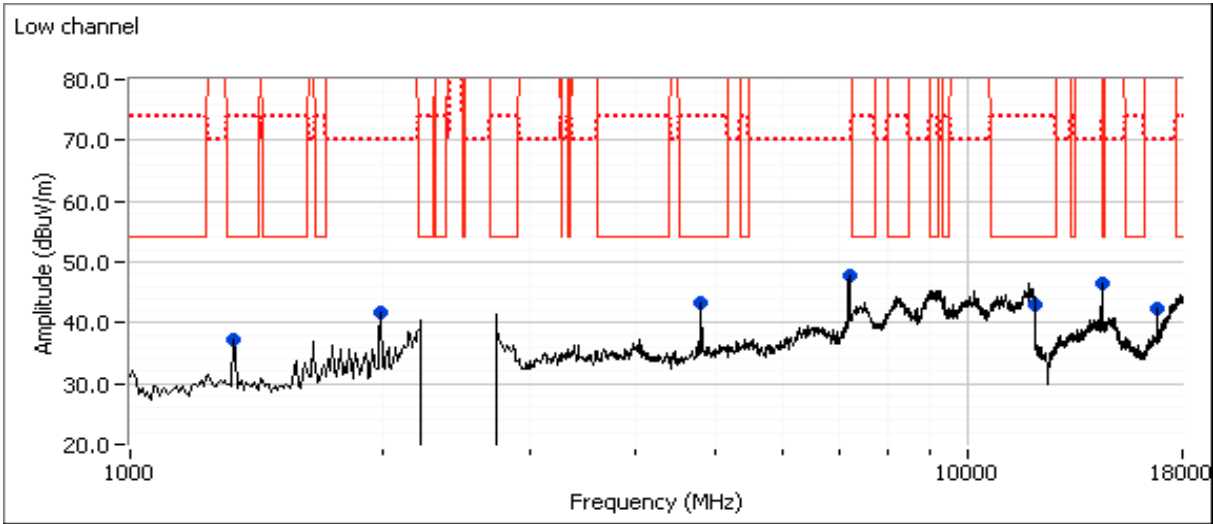

Client: Fitbit, Inc.	Job Number: J95447
Model: FB501 (Proton)	T-Log Number: T95507
	Project Manager: Deepa Shetty
Contact: Arndt Hufenbach	Project Coordinator: Irene Rademacher
Standard: FCC 15.247/RSS-210/LP 00002	Class: N/A

Run #1b: Center Channel

Channel: 2440 MHz Mode: LE
 Tx Chain: Main Data Rate: 1 Mb/s

Frequency MHz	Level dB μ V/m	Pol v/h	15.209 / 15.247		Detector Pk/QP/Avg	Azimuth degrees	Height meters	Comments
			Limit	Margin				
19518.340	52.9	H	54.0	-1.1	AVG	173	1.12	Note 3
19518.070	60.3	H	74.0	-13.7	PK	173	1.12	
1330.870	28.3	H	54.0	-25.7	AVG	56	2.04	
1332.130	41.7	H	74.0	-32.3	PK	56	2.04	
4879.970	38.8	V	54.0	-15.2	AVG	94	1.11	Note 3
4880.530	44.7	V	74.0	-29.3	PK	94	1.11	
7319.470	48.5	H	54.0	-5.5	AVG	210	1.49	Note 3
7320.650	54.0	H	74.0	-20.0	PK	210	1.49	
19516.670	48.7	H	54.0	-5.3	Peak	112	1.00	
17073.320	50.3	H	54.0	-3.7	AVG	39	0.97	Note 1, Note 3
17070.970	57.5	H	74.0	-16.5	PK	39	0.97	Note 1
12185.470	44.8	V	54.0	-9.2	AVG	168	0.97	Note 3
12191.430	52.0	V	74.0	-22.0	PK	168	0.97	
14638.780	52.4	V	54.0	-1.6	AVG	179	1.33	Note 1, Note 3
14641.680	59.6	V	74.0	-14.4	PK	179	1.33	Note 1

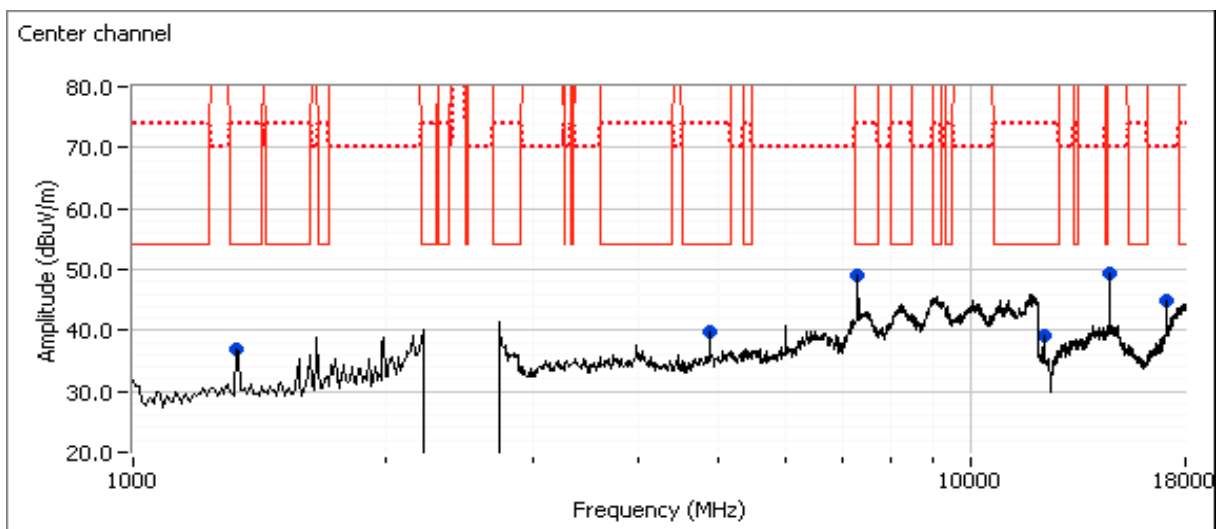

Client: Fitbit, Inc.	Job Number: J95447
Model: FB501 (Proton)	T-Log Number: T95507
	Project Manager: Deepa Shetty
Contact: Arndt Hufenbach	Project Coordinator: Irene Rademacher
Standard: FCC 15.247/RSS-210/LP 00002	Class: N/A

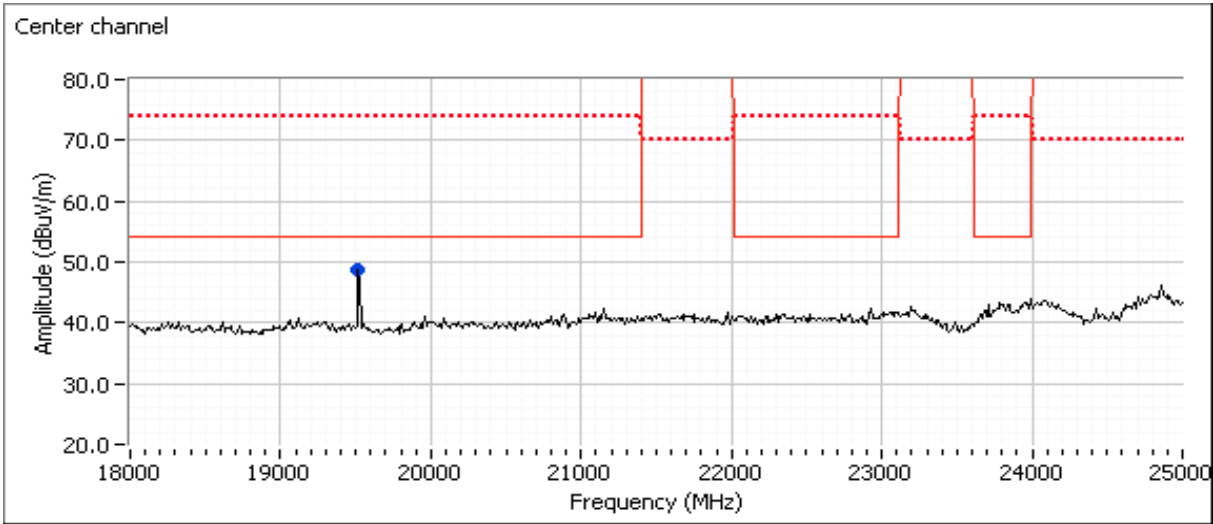



EMC Test Data

Client: Fitbit, Inc.	Job Number: J95447
Model: FB501 (Proton)	T-Log Number: T95507
	Project Manager: Deepa Shetty
Contact: Arndt Hufenbach	Project Coordinator: Irene Rademacher
Standard: FCC 15.247/RSS-210/LP 00002	Class: N/A

Run #1c: High Channel

Channel: 2480 MHz Mode: LE
 Tx Chain: Main Data Rate: 1 Mb/s

Frequency MHz	Level dB μ V/m	Pol v/h	15.209 / 15.247		Detector Pk/QP/Avg	Azimuth degrees	Height meters	Comments
			Limit	Margin				
17349.630	53.5	H	54.0	-0.5	AVG	15	0.97	Note 1, Note 3
17345.200	61.0	H	74.0	-13.0	PK	15	0.97	Note 1
1991.670	40.9	V	70.0	-29.1	Peak	284	1.0	Measured in run 1a. Not radio related.
4783.280	26.9	V	54.0	-27.1	AVG	97	1.00	Not radio related.
4783.320	41.8	V	74.0	-32.2	PK	97	1.00	Not radio related.
4959.860	35.4	H	54.0	-18.6	AVG	67	1.49	Note 3
4960.650	42.4	H	74.0	-31.6	PK	67	1.49	
7439.480	48.4	V	54.0	-5.6	AVG	119	1.54	Note 3
7439.380	54.5	V	74.0	-19.5	PK	119	1.54	
19838.000	50.7	H	54.0	-3.3	AVG	169	1.12	Note 3
19842.060	58.3	H	74.0	-15.7	PK	169	1.12	
24797.830	52.4	H	54.0	-1.6	AVG	358	1.23	Note 1, Note 3
24797.730	60.7	H	74.0	-13.3	PK	358	1.23	Note 1
12386.830	44.6	V	54.0	-9.4	AVG	162	1.47	Note 3
12385.720	52.5	V	74.0	-21.5	PK	162	1.47	
14878.700	52.9	V	54.0	-1.1	AVG	92	1.42	Note 1, Note 3
14878.580	60.1	V	74.0	-13.9	PK	92	1.42	Note 1

Client: Fitbit, Inc.	Job Number: J95447
Model: FB501 (Proton)	T-Log Number: T95507
Contact: Arndt Hufenbach	Project Manager: Deepa Shetty
Standard: FCC 15.247/RSS-210/LP 00002	Project Coordinator: Irene Rademacher
	Class: N/A

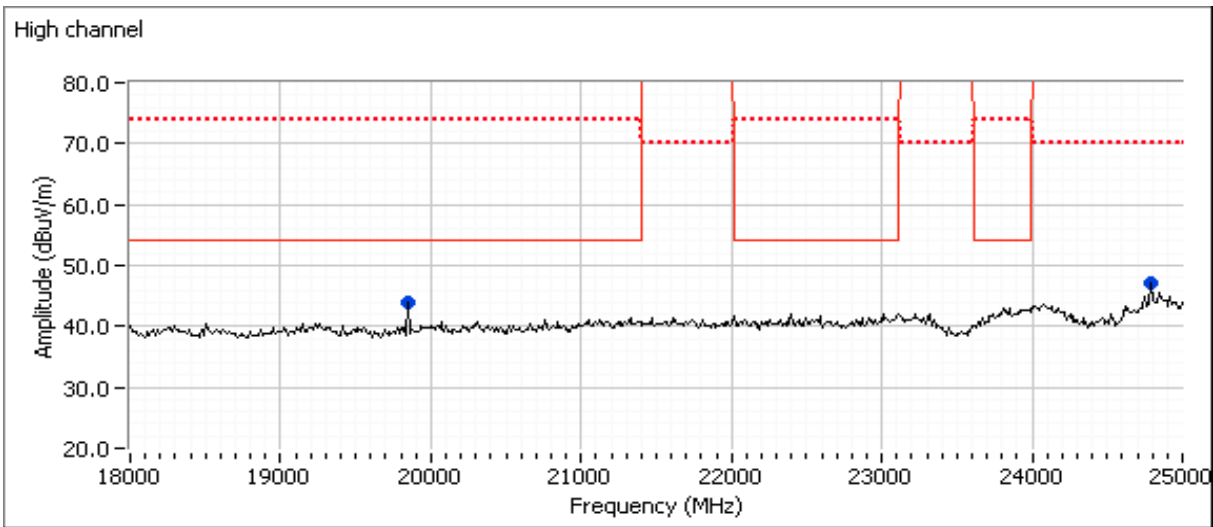
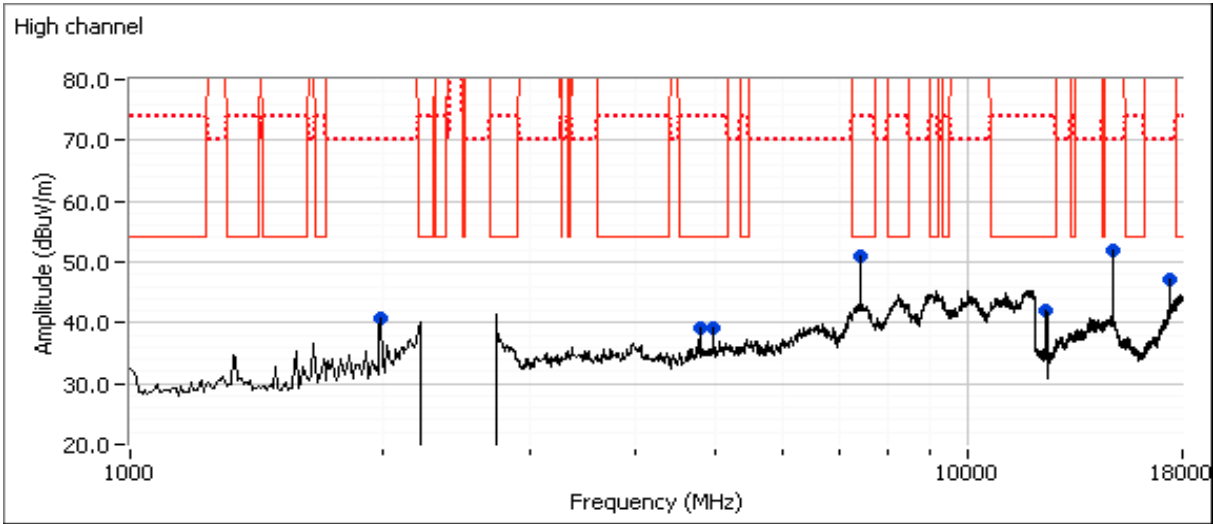



EMC Test Data

Client: Fitbit, Inc.	Job Number: J95447
Model: FB501 (Proton)	T-Log Number: T95507
Contact: Arndt Hufenbach	Project Manager: Deepa Shetty
Standard: FCC 15.247/RSS-210/LP 00002	Project Coordinator: Irene Rademacher
	Class: N/A

RSS 210 and FCC 15.247 (DTS) Radiated Spurious Emissions

Test Specific Details

Objective: The objective of this test session is to perform final qualification testing of the EUT with respect to the specification listed above.

General Test Configuration

The EUT and all local support equipment were located on the turntable for radiated spurious emissions testing. For radiated emissions testing the measurement antenna was located 3 meters from the EUT, unless otherwise noted.

Ambient Conditions:

Temperature: 24 °C
Rel. Humidity: 32 %

Summary of Results - Device Operating in the 2400-2483.5 MHz Band

Run #	Mode	Channel	Target Setting	Power Setting	Test Performed	Limit	Result / Margin
3	BLE	2402MHz	0F	0F	Restricted Band Edge (2390 MHz)	FCC Part 15.209 / 15.247(c)	37.1 dBµV/m @ 2335.6 MHz (-16.9 dB)
		2480MHz			Restricted Band Edge (2483.5 MHz)		38.8 dBµV/m @ 2483.5 MHz (-15.2 dB)

Modifications Made During Testing

No modifications were made to the EUT during testing

Deviations From The Standard

No deviations were made from the requirements of the standard.

Sample Notes

Sample S/N: 1
Driver: F13.1
Antenna: Internal

Notes

Device is handheld. Determination of worse case orientation was done as a measurement of the fundamental at the center channel.



EMC Test Data

Client: Fitbit, Inc.	Job Number: J95447
Model: FB501 (Proton)	T-Log Number: T95507
	Project Manager: Deepa Shetty
Contact: Arndt Hufenbach	Project Coordinator: Irene Rademacher
Standard: FCC 15.247/RSS-210/LP 00002	Class: N/A

Procedure Comments:

Measurements performed in accordance with FCC KDB 558074

Peak measurements performed with: RBW=1MHz, VBW=3MHz, peak detector, max hold, auto sweep time

Unless otherwise stated/noted, emission has duty cycle $\geq 98\%$ and was measured using RBW=1MHz, VBW=10Hz, peak detector, linear average mode, auto sweep time, max hold.

Mode	Data Rate	Duty Cycle (x)	Constant DC?	T (ms)	Pwr Cor Factor*	Lin Volt Cor Factor**	Min VBW for FS (Hz)
LE	1 Mb/s	0.65	Yes	0.408	1.8660738	3.7321476	2451

Measurement Specific Notes:

Note 3:	Emission has duty cycle $< 98\%$, but constant, average measurement performed: RBW=1MHz, VBW=10Hz, peak detector, linear averaging, auto sweep, trace average 100 traces, measurement corrected by Linear Voltage correction factor
Note 6:	Plots of the average and peak bandedge do not account for any duty cycle correction. Refer to the tabular results for final measurements.



EMC Test Data

Client: Fitbit, Inc.	Job Number: J95447
Model: FB501 (Proton)	T-Log Number: T95507
	Project Manager: Deepa Shetty
Contact: Arndt Hufenbach	Project Coordinator: Irene Rademacher
Standard: FCC 15.247/RSS-210/LP 00002	Class: N/A

Run #0: Worse Case Orientation

Date of Test: 7/11/2014 0:00
 Test Engineer: John Caizzi
 Test Location: Chamber 7

Config. Used: 1
 Config Change: no remote support equipment.
 Host Voltage: 120V / 60Hz

Channel: 2441MHz Mode: Basic
 Tx Chain: Main Data Rate: 1Mb/s

Frequency MHz	Level dB μ V/m	Pol v/h	15.209 / 15.247		Detector Pk/QP/Avg	Azimuth degrees	Height meters	Comments
			Limit	Margin				
2441.010	87.4	V	-	-	Pk	344	1.00	Side
2441.090	91.0	H	-	-	Pk	0	2.16	Side
2441.030	87.3	V	-	-	Pk	349	1.00	Face down
2441.070	92.3	H	-	-	Pk	17	2.16	Face down
2440.970	89.2	V	-	-	Pk	346	1.00	Upright
2441.070	85.4	H	-	-	Pk	0	2.15	Upright

Note 7 | All measurements made with RBW = 100 kHz, VBW = 300 kHz.



EMC Test Data

Client: Fitbit, Inc.	Job Number: J95447
Model: FB501 (Proton)	T-Log Number: T95507
	Project Manager: Deepa Shetty
Contact: Arndt Hufenbach	Project Coordinator: Irene Rademacher
Standard: FCC 15.247/RSS-210/LP 00002	Class: N/A

Run #3: Radiated Bandedge Measurements

Date of Test: 7/29/2014 0:00
 Test Engineer: John Caizzi
 Test Location: Chamber 5

Config. Used: 1
 Config Change: none
 Host Voltage: 120V / 60Hz

Channel: 2402 MHz Mode: LE
 Tx Chain: Main Data Rate: 1 Mb/s

Band Edge Signal Field Strength - Direct measurement of field strength

Frequency	Level	Pol	15.209 / 15.247		Detector	Azimuth	Height	Comments
MHz	dB μ V/m	v/h	Limit	Margin	Pk/QP/Avg	degrees	meters	
2335.550	37.1	H	54.0	-16.9	AVG	0	1.47	
2334.790	46.3	H	74.0	-27.7	PK	0	1.47	
2247.210	37.1	V	54.0	-16.9	AVG	360	1.00	
2362.590	45.2	V	74.0	-28.8	PK	360	1.00	

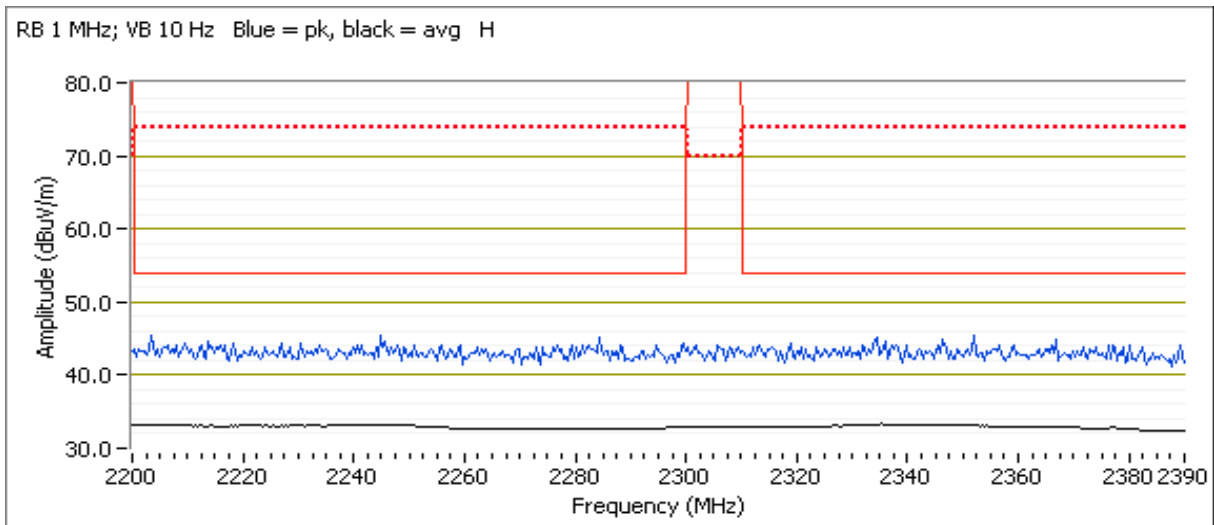

Client: Fitbit, Inc.	Job Number: J95447
Model: FB501 (Proton)	T-Log Number: T95507
Contact: Arndt Hufenbach	Project Manager: Deepa Shetty
Standard: FCC 15.247/RSS-210/LP 00002	Project Coordinator: Irene Rademacher
	Class: N/A

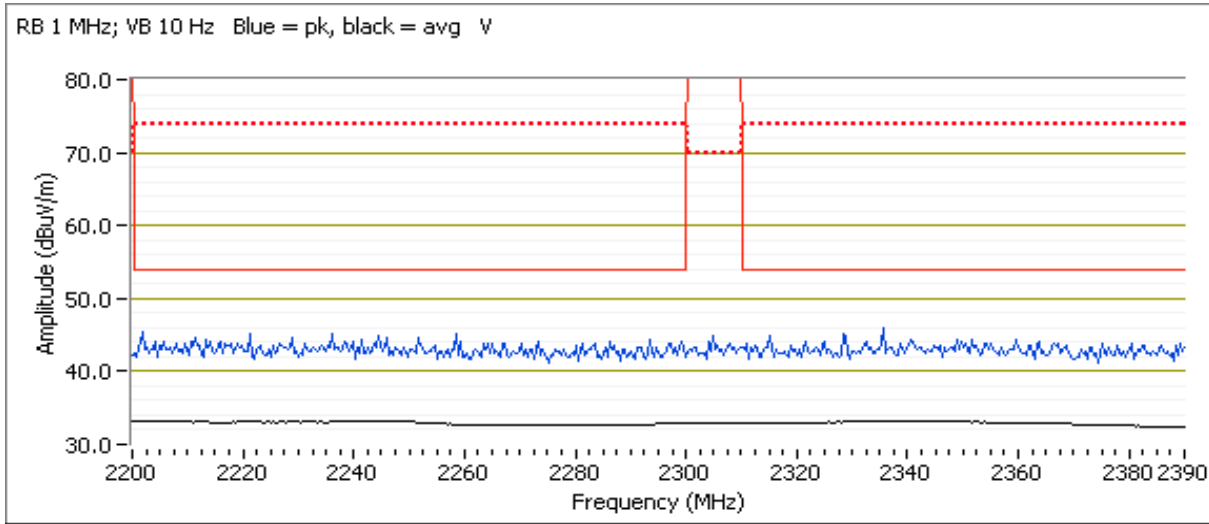



EMC Test Data

Client: Fitbit, Inc.	Job Number: J95447
Model: FB501 (Proton)	T-Log Number: T95507
Contact: Arndt Hufenbach	Project Manager: Deepa Shetty
Standard: FCC 15.247/RSS-210/LP 00002	Project Coordinator: Irene Rademacher
	Class: N/A

Channel: 2480 MHz Mode: LE
 Tx Chain: Main Data Rate: 1 Mb/s

Band Edge Signal Field Strength - Direct measurement of field strength

Frequency MHz	Level dB μ V/m	Pol v/h	15.209 / 15.247		Detector PK/QP/Avg	Azimuth degrees	Height meters	Comments
			Limit	Margin				
2483.530	38.8	H	54.0	-15.2	AVG	17	1.77	
2488.630	47.6	H	74.0	-26.4	PK	17	1.77	
2486.840	38.1	V	54.0	-15.9	AVG	137	1.00	
2486.580	46.4	V	74.0	-27.6	PK	137	1.00	

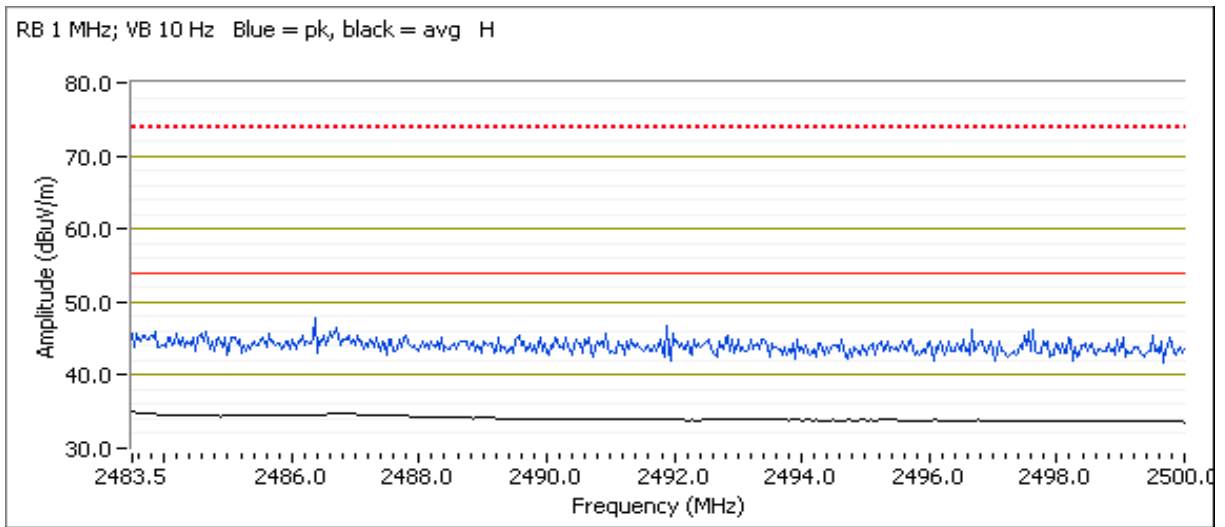



EMC Test Data

Client:	Fitbit, Inc.	Job Number:	J95447
Product:	FB501 (Proton)	T-Log Number:	T95502
		Project Manager:	Deepa Shetty
Contact:	Arndt Hufenbach	Project Coordinator:	Irene Rademacher
Emissions Standard(s):	FCC 15B / EN55022 / CNS 13438	Class:	-
Immunity Standard(s):	EN 55024 / EN 301 489-1/-3/-17	Environment:	-

EMC Test Data

For The

Fitbit, Inc.

Product

FB501 (Proton)

Date of Last Test: 7/22/2014



EMC Test Data

Client: Fitbit, Inc.	Job Number: J95447
Model: FB501 (Proton)	T-Log Number: T95502
	Project Manager: Deepa Shetty
Contact: Arndt Hufenbach	Project Coordinator: Irene Rademacher
Standard: FCC 15B / EN55022 / CNS 13438	Class: -

Conducted Emissions

(Elliott Laboratories Fremont Facility, Semi-Anechoic Chamber)

Test Specific Details

Objective: The objective of this test session is to perform final qualification testing of the EUT with respect to the specification listed above.

Date of Test: 7/7/2014	Config. Used: 1
Test Engineer: Alika Hirano	Config Change: None
Test Location: Fremont Chamber #3	Host Unit Voltage 120V/60Hz & 220V/60Hz

General Test Configuration

For tabletop equipment, the host system was located on a wooden table inside the semi-anechoic chamber, 40 cm from a vertical coupling plane and 80cm from the LISN. Remote support equipment was located outside of the semi-anechoic chamber. Any cables running to remote support equipment where routed through metal conduit and when possible passed through a ferrite clamp upon exiting the chamber.

Ambient Conditions:	Temperature: 24 °C
	Rel. Humidity: 36 %

Summary of Results

Run #	Test Performed	Limit	Result	Margin
1	CE, AC Power, 110V/60Hz	FCC 15.207	Pass	49.3 dBµV @ 0.157 MHz (-16.3 dB)

Modifications Made During Testing

No modifications were made to the EUT during testing

Deviations From The Standard

No deviations were made from the requirements of the standard.

Notes

EUT is a PC peripheral. Testing performed connected to a host computer and setup in accordance with ANSI 63.4
 BT radio should be transmitting (active) and GPS active
 Results to be used for FCC 15.207 compliance

Client: Fitbit, Inc.	Job Number: J95447
Model: FB501 (Proton)	T-Log Number: T95502
Contact: Arndt Hufenbach	Project Manager: Deepa Shetty
Standard: FCC 15B / EN55022 / CNS 13438	Project Coordinator: Irene Rademacher
	Class: -

Run #1: AC Power Port Conducted Emissions, 0.15 - 30MHz, 110V/60Hz

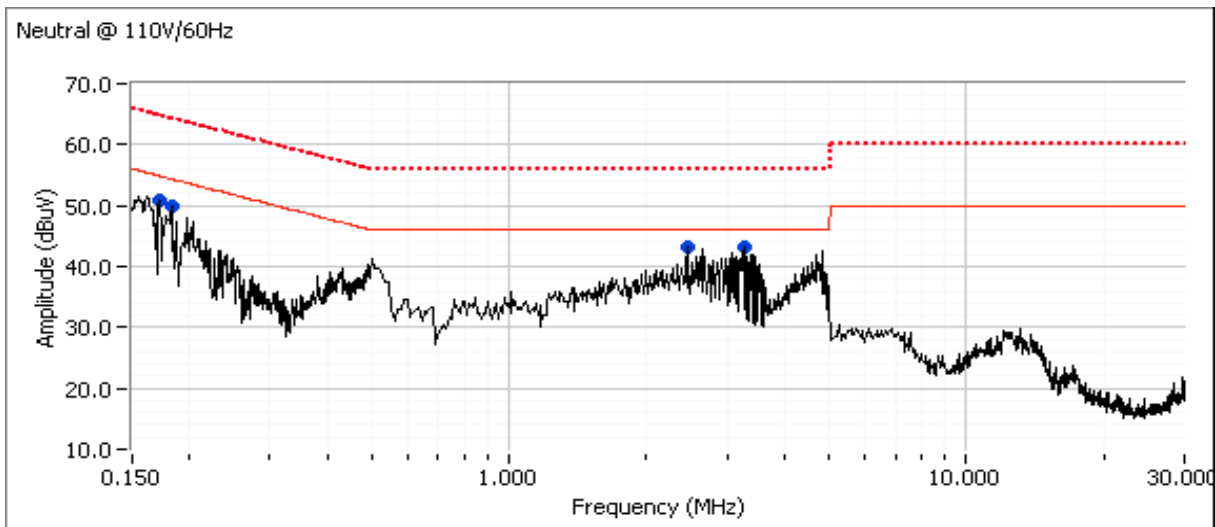
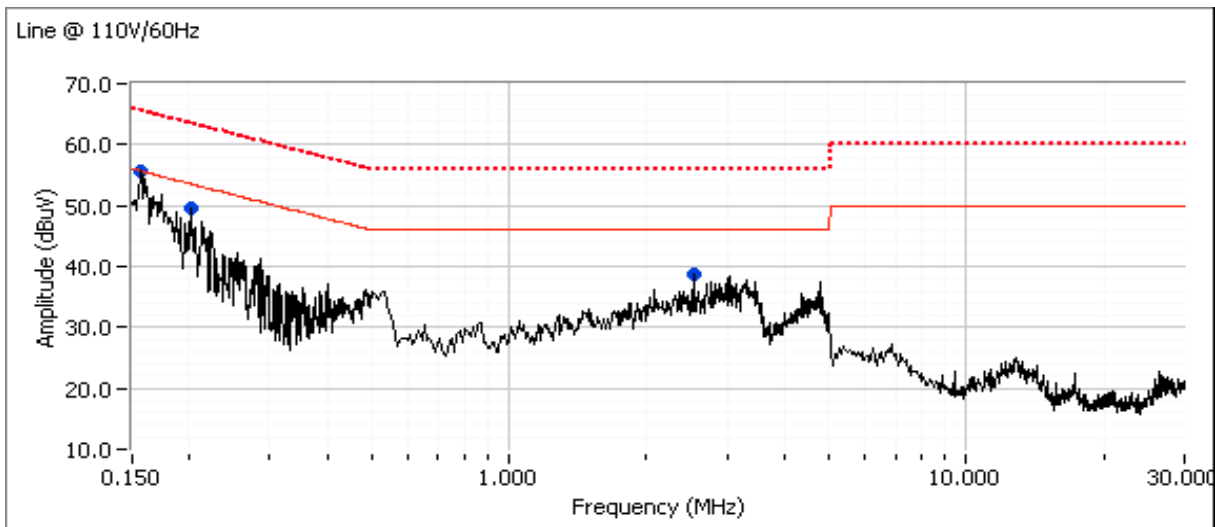



EMC Test Data

Client: Fitbit, Inc.	Job Number: J95447
Model: FB501 (Proton)	T-Log Number: T95502
	Project Manager: Deepa Shetty
Contact: Arndt Hufenbach	Project Coordinator: Irene Rademacher
Standard: FCC 15B / EN55022 / CNS 13438	Class: -

Preliminary peak readings captured during pre-scan (peak readings vs. average limit)

Frequency MHz	Level dB μ V	AC Line	15.207		Detector QP/Ave	Comments
			Limit	Margin		
0.157	55.6	Line 1	55.6	0.0	Peak	
0.201	49.6	Line 1	53.6	-4.0	Peak	
2.523	38.6	Line 1	46.0	-7.4	Peak	
0.171	50.9	Neutral	54.9	-4.0	Peak	
0.184	49.9	Neutral	54.3	-4.4	Peak	
2.473	43.1	Neutral	46.0	-2.9	Peak	
3.242	43.1	Neutral	46.0	-2.9	Peak	

Final quasi-peak and average readings

Frequency MHz	Level dB μ V	AC Line	15.207		Detector QP/Ave	Comments
			Limit	Margin		
0.157	49.3	Line 1	65.6	-16.3	QP	QP (1.00s)
2.473	27.3	Neutral	46.0	-18.7	AVG	AVG (0.10s)
0.170	45.6	Neutral	65.0	-19.4	QP	QP (1.00s)
3.242	36.5	Neutral	56.0	-19.5	QP	QP (1.00s)
0.184	43.0	Neutral	64.3	-21.3	QP	QP (1.00s)
3.242	24.6	Neutral	46.0	-21.4	AVG	AVG (0.10s)
2.473	34.4	Neutral	56.0	-21.6	QP	QP (1.00s)
0.201	42.0	Line 1	63.6	-21.6	QP	QP (1.00s)
0.157	32.1	Line 1	55.6	-23.5	AVG	AVG (0.10s)
2.523	22.2	Line 1	46.0	-23.8	AVG	AVG (0.10s)
2.523	29.2	Line 1	56.0	-26.8	QP	QP (1.00s)
0.170	26.9	Neutral	55.0	-28.1	AVG	AVG (0.10s)
0.201	25.5	Line 1	53.6	-28.1	AVG	AVG (0.10s)
0.184	25.8	Neutral	54.3	-28.5	AVG	AVG (0.10s)

End of Report

This page is intentionally blank and marks the last page of this test report.