

## **EMC Test Report**

### **Application for FCC Grant of Equipment Authorization Canada Certification**

### **Innovation, Science and Economic Development Canada RSS-Gen Issue 4 / RSS 247 Issue 1 FCC Part 15 Subpart C**

#### **Model: FB403**

IC CERTIFICATION #: 8542A-FB403  
FCC ID: XRAFB403

APPLICANT: Fitbit, Inc.  
405 Howard Street  
San Francisco, CA 94105

TEST SITE(S): National Technical Systems - Silicon Valley  
41039 Boyce Road.  
Fremont, CA. 94538-2435

IC SITE REGISTRATION #: 2845B-7

REVISION DATE: August 19, 2016

REPORT DATE: July 29, 2016

FINAL TEST DATES: June 3, 6, 14, 15, 29, 30, July 1, 5, 7, and 25,  
2016

TOTAL NUMBER OF PAGES: 56

PROGRAM MGR /  
TECHNICAL REVIEWER:



Mark E Hill  
Staff Engineer

QUALITY ASSURANCE DELEGATE /  
FINAL REPORT PREPARER:



David Guidotti  
Senior Technical Writer



National Technical Systems - Silicon Valley is accredited by the A2LA, certificate number 0214.26, to perform the test(s) listed in this report, except where noted otherwise. This report and the information contained herein represent the results of testing test articles identified and selected by the client performed to specifications and/or procedures selected by the client. National Technical Systems (NTS) makes no representations, expressed or implied, that such testing is adequate (or inadequate) to demonstrate efficiency, performance, reliability, or any other characteristic of the articles being tested, or similar products. This report should not be relied upon as an endorsement or certification by NTS of the equipment tested, nor does it represent any statement whatsoever as to its merchantability or fitness of the test article, or similar products, for a particular purpose. This report shall not be reproduced except in full

**REVISION HISTORY**

Rev#	Date	Comments	Modified By
-	July 29, 2016	First release	
1.0	August 19, 2016	Clarified EUT serial numbers	

---

**TABLE OF CONTENTS**

<b>REVISION HISTORY .....</b>	<b>2</b>
<b>TABLE OF CONTENTS .....</b>	<b>3</b>
<b>SCOPE.....</b>	<b>4</b>
<b>OBJECTIVE .....</b>	<b>4</b>
<b>STATEMENT OF COMPLIANCE .....</b>	<b>5</b>
<b>DEVIATIONS FROM THE STANDARDS .....</b>	<b>5</b>
<b>TEST RESULTS SUMMARY .....</b>	<b>6</b>
DIGITAL TRANSMISSION SYSTEMS (2400 – 2483.5MHZ) .....	6
MEASUREMENT UNCERTAINTIES .....	7
<b>EQUIPMENT UNDER TEST (EUT) DETAILS .....</b>	<b>8</b>
GENERAL.....	8
OTHER EUT DETAILS.....	8
ANTENNA SYSTEM.....	8
ENCLOSURE.....	8
MODIFICATIONS .....	8
SUPPORT EQUIPMENT.....	9
EUT INTERFACE PORTS .....	9
EUT OPERATION .....	10
<b>TEST SITE.....</b>	<b>11</b>
GENERAL INFORMATION .....	11
CONDUCTED EMISSIONS CONSIDERATIONS.....	11
RADIATED EMISSIONS CONSIDERATIONS.....	11
<b>MEASUREMENT INSTRUMENTATION .....</b>	<b>12</b>
RECEIVER SYSTEM .....	12
INSTRUMENT CONTROL COMPUTER .....	12
LINE IMPEDANCE STABILIZATION NETWORK (LISN) .....	12
FILTERS/ATTENUATORS.....	13
ANTENNAS.....	13
ANTENNA MAST AND EQUIPMENT TURNTABLE .....	13
INSTRUMENT CALIBRATION .....	13
<b>TEST PROCEDURES.....</b>	<b>14</b>
EUT AND CABLE PLACEMENT.....	14
CONDUCTED EMISSIONS.....	14
RADIATED EMISSIONS .....	15
CONDUCTED EMISSIONS FROM ANTENNA PORT.....	17
BANDWIDTH MEASUREMENTS .....	17
SPECIFICATION LIMITS AND SAMPLE CALCULATIONS.....	18
CONDUCTED EMISSIONS SPECIFICATION LIMITS: FCC 15.207; FCC 15.107(A), RSS GEN.....	18
GENERAL TRANSMITTER RADIATED EMISSIONS SPECIFICATION LIMITS.....	19
OUTPUT POWER LIMITS – DIGITAL TRANSMISSION SYSTEMS.....	19
TRANSMIT MODE SPURIOUS RADIATED EMISSIONS LIMITS – FHSS AND DTS SYSTEMS .....	19
SAMPLE CALCULATIONS - CONDUCTED EMISSIONS .....	20
SAMPLE CALCULATIONS - RADIATED EMISSIONS .....	20
SAMPLE CALCULATIONS - FIELD STRENGTH TO EIRP CONVERSION .....	21
<b>APPENDIX A TEST EQUIPMENT CALIBRATION DATA.....</b>	<b>22</b>
<b>APPENDIX B TEST DATA.....</b>	<b>25</b>
<b>END OF REPORT.....</b>	<b>56</b>

## **SCOPE**

An electromagnetic emissions test has been performed on the Fitbit, Inc. model FB403, pursuant to the following rules:

RSS-Gen Issue 4 “General Requirements for Compliance of Radio Apparatus”  
RSS 247 Issue 1 “Digital Transmission Systems (DTSs), Frequency Hopping Systems (FHSS) and Licence-Exempt Local Area Network (LE-LAN) Devices”  
FCC Part 15 Subpart C

Conducted and radiated emissions data has been collected, reduced, and analyzed within this report in accordance with measurement guidelines set forth in the following reference standards and as outlined in National Technical Systems - Silicon Valley test procedures:

ANSI C63.10-2013  
FCC DTS Measurement Guidance KDB558074

The intentional radiator above has been tested in a simulated typical installation to demonstrate compliance with the relevant Industry Canada performance and procedural standards.

Final system data was gathered in a mode that tended to maximize emissions by varying orientation of EUT, orientation of power and I/O cabling, antenna search height, and antenna polarization.

Every practical effort was made to perform an impartial test using appropriate test equipment of known calibration. All pertinent factors have been applied to reach the determination of compliance.

## **OBJECTIVE**

The primary objective of the manufacturer is compliance with the regulations outlined in the previous section.

Prior to marketing in the USA, all unlicensed transmitters and transceivers require certification. Receive-only devices operating between 30 MHz and 960 MHz are subject to either certification or a manufacturer’s declaration of conformity, with all other receive-only devices exempt from the technical requirements.

Prior to marketing in Canada, Class I transmitters, receivers and transceivers require certification. Class II devices are required to meet the appropriate technical requirements but are exempt from certification requirements.

Certification is a procedure where the manufacturer submits test data and technical information to a certification body and receives a certificate or grant of equipment authorization upon successful completion of the certification body’s review of the submitted documents. Once the equipment authorization has been obtained, the label indicating compliance must be attached to all identical units, which are subsequently

manufactured.

Maintenance of compliance is the responsibility of the manufacturer. Any modification of the product which may result in increased emissions should be checked to ensure compliance has been maintained (i.e., printed circuit board layout changes, different line filter, different power supply, harnessing or I/O cable changes, etc.).

### **STATEMENT OF COMPLIANCE**

The tested sample of Fitbit, Inc. model FB403 complied with the requirements of the following regulations:

RSS-Gen Issue 4 “ General Requirements for Compliance of Radio Apparatus”  
RSS 247 Issue 1 “Digital Transmission Systems (DTSs), Frequency Hopping  
Systems (FHSS) and Licence-Exempt Local Area Network (LE-LAN) Devices”  
FCC Part 15 Subpart C

Maintenance of compliance is the responsibility of the manufacturer. Any modifications to the product should be assessed to determine their potential impact on the compliance status of the device with respect to the standards detailed in this test report.

The test results recorded herein are based on a single type test of Fitbit, Inc. model FB403 and therefore apply only to the tested sample. The sample was selected and prepared by Sachin Sawalapurkar of Fitbit, Inc.

### **DEVIATIONS FROM THE STANDARDS**

No deviations were made from the published requirements listed in the scope of this report.

## TEST RESULTS SUMMARY

### DIGITAL TRANSMISSION SYSTEMS (2400 – 2483.5MHz)

FCC Rule Part	RSS Rule Part	Description	Measured Value / Comments	Limit / Requirement	Result
15.247(a)	RSS 247 5.2	Digital Modulation	Systems uses OFDM / DSSS techniques	System must utilize a digital transmission technology	Complies
15.247 (a) (2)	RSS 247 5.2 (1)	6dB Bandwidth	0.71 MHz	>500kHz	Complies
15.247 (b) (3)	RSS 247 5.4 (4)	Output Power (multipoint systems)	4.0 dBm (0.0025 Watts) EIRP = 2.0mW <sup>Note 1</sup>	1Watt, EIRP limited to 4 Watts.	Complies
15.247(e)	RSS 247 5.2 (2)	Power Spectral Density	-6.7 dBm/10kHz	8dBm/3kHz	Complies
15.247(d)	RSS 247 5.5	Antenna Port Spurious Emissions 30MHz – 25 GHz	all below -30dBc	< -30dBc <sup>Note 2</sup>	Complies
15.247(d) / 15.209	RSS 247 5.5	Radiated Spurious Emissions 30MHz – 25 GHz	48.2 dBμV/m @ 12398.8 MHz (-5.8 dB)	Refer to the limits section (p19) for restricted bands, all others <-30dBc <sup>Note 2</sup>	Complies
Note 1: EIRP calculated using antenna gains of -2.0 dBi for the highest EIRP system. Note 2: Limit of -30dBc used because the power was measured using the UNII test procedure (maximum power averaged over a transmission burst).					

### GENERAL REQUIREMENTS APPLICABLE TO ALL BANDS

FCC Rule Part	RSS Rule part	Description	Measured Value / Comments	Limit / Requirement	Result (margin)
15.203	-	RF Connector	Antenna is internal	Unique or integral antenna required	Complies
15.407 (b) (6)	RSS-Gen Table 3	AC Conducted Emissions	20.3 dBμV @ 0.590 MHz (-25.7 dB)	Refer to page 18	Complies
15.247 (i) 15.407 (f)	RSS 102	RF Exposure Requirements	Refer to SAR exclusion calculations in separate exhibit and RSS 102 declaration	Refer to OET 65, FCC Part 1 and RSS 102	Complies
-	RSP-100 RSS-Gen 6.6	Occupied Bandwidth	1.05MHz	Information only	N/A

**MEASUREMENT UNCERTAINTIES**

ISO/IEC 17025 requires that an estimate of the measurement uncertainties associated with the emissions test results be included in the report. The measurement uncertainties given below are based on a 95% confidence level and were calculated in accordance with UKAS document LAB 34.

Measurement Type	Measurement Unit	Frequency Range	Expanded Uncertainty
RF power, conducted (power meter)	dBm	25 to 7000 MHz	$\pm 0.52$ dB
RF power, conducted (Spectrum analyzer)	dBm	25 to 7000 MHz	$\pm 0.7$ dB
Conducted emission of transmitter	dBm	25 to 26500 MHz	$\pm 0.7$ dB
Conducted emission of receiver	dBm	25 to 26500 MHz	$\pm 0.7$ dB
Radiated emission (substitution method)	dBm	25 to 26500 MHz	$\pm 2.5$ dB
Radiated emission (field strength)	dB $\mu$ V/m	25 to 1000 MHz	$\pm 3.6$ dB
		1000 to 40000 MHz	$\pm 6.0$ dB
Conducted Emissions (AC Power)	dB $\mu$ V	0.15 to 30 MHz	$\pm 2.4$ dB

**EQUIPMENT UNDER TEST (EUT) DETAILS****GENERAL**

The Fitbit, Inc. model FB403 is a Wireless Activity Tracker. The EUT was treated as handheld equipment during testing to simulate the end-user environment. The EUT is powered via a rechargeable Li battery.

The sample was received on June 3, 2016 and tested on June 3, 6, 14, 15, 29, 30, July 1, 5, 7, and 25, 2016. The EUT consisted of the following component(s):

Company	Model	Description	Serial Number	FCC ID
Fitbit	FB403	Fitness Tracker	0x180b9126b042 (radiated sample)	XRAFB403
Fitbit	FB403	Fitness Tracker	0x188597a6a862 (RF conducted sample)	XRAFB403

**OTHER EUT DETAILS**

Bluetooth Low Energy mode only, does not support Basic/EDR operation  
A modified sample with a temporary RF port was provided for antenna port measurements.

**ANTENNA SYSTEM**

Internal antenna, -2.0dBi

**ENCLOSURE**

The EUT enclosure is primarily constructed of plastic with a metal frame. It measures approximately 3 cm wide by 0.7 cm deep by 0.5 cm high.

**MODIFICATIONS**

No modifications were made to the EUT during the time the product was at NTS Silicon Valley.



**SUPPORT EQUIPMENT**

The following equipment was used as support equipment for testing:

**Radiated Measurement**

Company	Model	Description	Serial Number
Belkin	F8Z981	AC USB Adapter	N/A
Fitbit	-	Charging cable	-

**Antenna Conducted**

Company	Model	Description	Serial Number	FCC ID
Fitbit	NA	Test fixture	-	N/A
Lenovo	T430	Laptop	-	N/A
Lenovo		Laptop power supply	-	N/A

The following equipment was used as remote support equipment for emissions testing:

**Radiated Measurements**

Company	Model	Description	Serial Number	FCC ID
Lenovo	T430	Laptop*		
Lenovo		Laptop power supply*		
Fitbit	NA	Test fixture*	NA	

\* - These items were used to configure the EUT then disconnected

**EUT INTERFACE PORTS**

The I/O cabling configuration during testing was as follows:

**Radiated Measurements**

Port	Connected To	Description	Cable(s)	
			Shielded or Unshielded	Length(m)
EUT contacts	Charge cable	Spring loaded pins	NA	NA
USB (charger)	Charge cable	Multiwire	Shielded	0.1
AC in (charger)	AC mains	Direct plug-in	NA	NA

**Antenna Conducted**

Port	Connected To	Description	Cable(s)	
			Shielded or Unshielded	Length(m)
EUT contacts	Test fixture	Spring loaded pins	NA	NA
Antenna	Spectrum analyzer	Coax	Shielded	1

**Antenna Conducted (Additional on Support Equipment)**

Port	Connected To	Description	Cable(s)	
			Shielded or Unshielded	Length(m)
USB (test fixture)	Laptop	Multiwire	Shielded	1
DC in (laptop)	Laptop power supply	2 wire	Unshielded	2
AC in (power supply)	AC mains	2 wire	Unshielded	1

***EUT OPERATION***

During emissions testing the EUT was either transmitting at full power or receiving on the channel called out in the individual test.

**TEST SITE****GENERAL INFORMATION**

Final test measurements were taken at the test sites listed below. Pursuant to section 2.948 of the FCC's Rules and section 3.3 of RSP-100, construction, calibration, and equipment data has been filed with the Commission and with industry Canada.

Site	Designation / Registration Numbers		Location
	FCC	Canada	
Chamber 7	US0027	2845B-7	41039 Boyce Road Fremont, CA 94538-2435

ANSI C63.4 recommends that ambient noise at the test site be at least 6 dB below the allowable limits. Ambient levels are below this requirement. The test site(s) contain separate areas for radiated and conducted emissions testing. Considerable engineering effort has been expended to ensure that the facilities conform to all pertinent requirements of ANSI C63.4.

**CONDUCTED EMISSIONS CONSIDERATIONS**

Conducted emissions testing is performed in conformance with ANSI C63.10. Measurements are made with the EUT connected to the public power network through a nominal, standardized RF impedance, which is provided by a line impedance stabilization network, known as a LISN. A LISN is inserted in series with each current-carrying conductor in the EUT power cord.

**RADIATED EMISSIONS CONSIDERATIONS**

The FCC has determined that radiation measurements made in a shielded enclosure are not suitable for determining levels of radiated emissions. Radiated measurements are performed in an open field environment or in a semi-anechoic chamber. The test sites are maintained free of conductive objects within the CISPR defined elliptical area incorporated in ANSI C63.4 guidelines and meet the Normalized Site Attenuation (NSA) requirements of ANSI C63.4.

## **MEASUREMENT INSTRUMENTATION**

### **RECEIVER SYSTEM**

An EMI receiver as specified in CISPR 16-1-1 is used for emissions measurements. The receivers used can measure over the frequency range of 9 kHz up to 2000 MHz. These receivers allow both ease of measurement and high accuracy to be achieved. The receivers have Peak, Average, and CISPR (Quasi-peak) detectors built into their design so no external adapters are necessary. The receiver automatically sets the required bandwidth for the CISPR detector used during measurements. If the repetition frequency of the signal being measured is below 20Hz, peak measurements are made in lieu of Quasi-Peak measurements.

For measurements above the frequency range of the receivers, a spectrum analyzer is utilized because it provides visibility of the entire spectrum along with the precision and versatility required to support engineering analysis. Average measurements above 1000MHz are performed on the spectrum analyzer using the linear-average method with a resolution bandwidth of 1 MHz and a video bandwidth of 10 Hz, unless the signal is pulsed in which case the average (or video) bandwidth of the measuring instrument is reduced to onset of pulse desensitization and then increased.

### **INSTRUMENT CONTROL COMPUTER**

Software is used to view and convert receiver measurements to the field strength at an antenna or voltage developed at the LISN measurement port, which is then compared directly with the appropriate specification limit. This provides faster, more accurate readings by performing the conversions described under Sample Calculations within the Test Procedures section of this report. Results are printed in a graphic and/or tabular format, as appropriate. A personal computer is used to record all measurements made with the receivers. The software used for radiated and conducted emissions measurements is NTS EMI Test Software (rev 2.10)

### **LINE IMPEDANCE STABILIZATION NETWORK (LISN)**

Line conducted measurements utilize a fifty microhenry Line Impedance Stabilization Network as the monitoring point. The LISN used also contains a 250 uH CISPR adapter. This network provides for calibrated radio frequency noise measurements by the design of the internal low pass and high pass filters on the EUT and measurement ports, respectively.

**FILTERS/ATTENUATORS**

External filters and precision attenuators are often connected between the receiving antenna or LISN and the receiver. This eliminates saturation effects and non-linear operation due to high amplitude transient events.

**ANTENNAS**

A loop antenna is used below 30 MHz. For the measurement range 30 MHz to 1000 MHz either a combination of a biconical antenna and a log periodic or a bi-log antenna is used. Above 1000 MHz, horn antennas are used. The antenna calibration factors to convert the received voltage to an electric field strength are included with appropriate cable loss and amplifier gain factors to determine an overall site factor, which is then programmed into the test receivers or incorporated into the test software.

**ANTENNA MAST AND EQUIPMENT TURNTABLE**

The antennas used to measure the radiated electric field strength are mounted on a non-conductive antenna mast equipped with a motor-drive to vary the antenna height. Measurements below 30 MHz are made with the loop antenna at a fixed height of 1m above the ground plane.

ANSI C63.10:2013 specifies that the test height above ground for table mounted devices shall be 1.5m for measurements above 1GHz, and 80 centimeters for measurements below 1GHz. Floor mounted equipment shall be placed on the ground plane if the device is normally used on a conductive floor or separated from the ground plane by insulating material from 3 to 12 mm if the device is normally used on a non-conductive floor. During radiated measurements, the EUT is positioned on a motorized turntable in conformance with this requirement.

**INSTRUMENT CALIBRATION**

All test equipment is regularly checked to ensure that performance is maintained in accordance with the manufacturer's specifications. All antennas are calibrated at regular intervals with respect to tuned half-wave dipoles. An exhibit of this report contains the list of test equipment used and calibration information.

## TEST PROCEDURES

### EUT AND CABLE PLACEMENT

The regulations require that interconnecting cables be connected to the available ports of the unit and that the placement of the unit and the attached cables simulate the worst case orientation that can be expected from a typical installation, so far as practicable. To this end, the position of the unit and associated cabling is varied within the guidelines of ANSI C63.10, and the worst-case orientation is used for final measurements.

### CONDUCTED EMISSIONS

Conducted emissions are measured at the plug end of the power cord supplied with the EUT. Excess power cord length is wrapped in a bundle between 30 and 40 centimeters in length near the center of the cord. Preliminary measurements are made to determine the highest amplitude emission relative to the specification limit for all the modes of operation. Placement of system components and varying of cable positions are performed in each mode. A final peak mode scan is then performed in the position and mode for which the highest emission was noted on all current carrying conductors of the power cord.

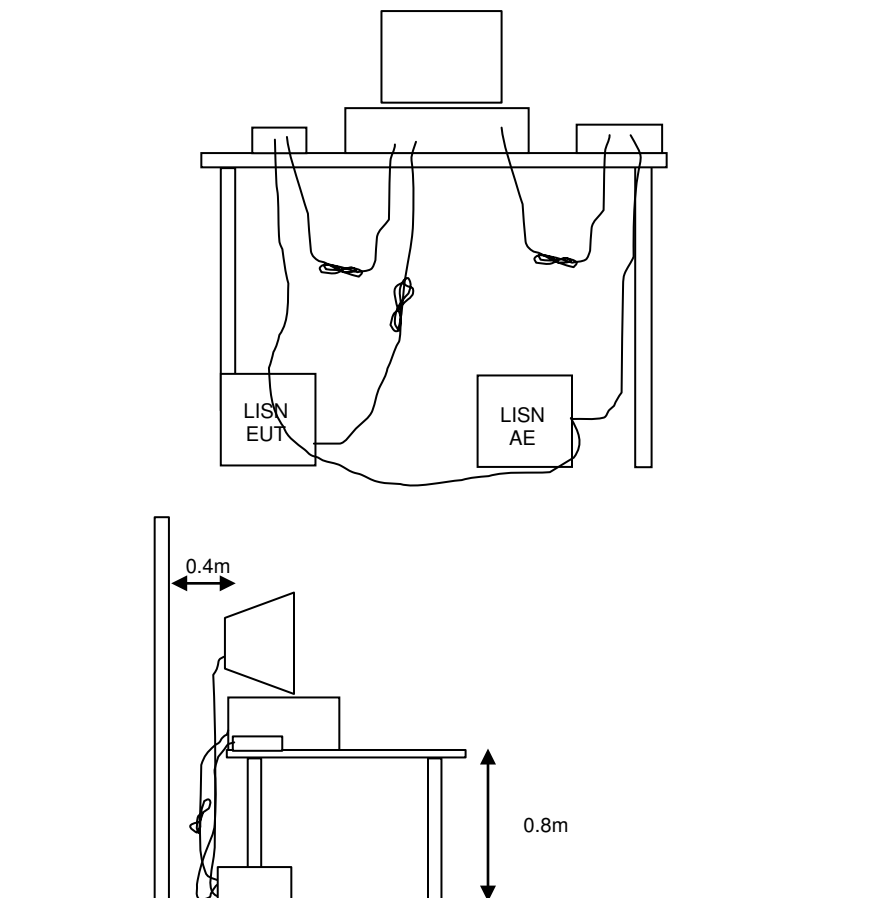

Figure 1 Typical Conducted Emissions Test Configuration

**RADIATED EMISSIONS**

A preliminary scan of the radiated emissions is performed in which all significant EUT frequencies are identified with the system in a nominal configuration. At least two scans are performed, one scan for each antenna polarization (horizontal and vertical; loop parallel and perpendicular to the EUT). During the preliminary scans, the EUT is rotated through 360°, the antenna height is varied (for measurements above 30 MHz) and cable positions are varied to determine the highest emission relative to the limit. Preliminary scans may be performed in a fully anechoic chamber for the purposes of identifying the frequencies of the highest emissions from the EUT.

A speaker is provided in the receiver to aid in discriminating between EUT and ambient emissions. Other methods used during the preliminary scan for EUT emissions involve scanning with near field magnetic loops, monitoring I/O cables with RF current clamps, and cycling power to the EUT.

Final maximization is a phase in which the highest amplitude emissions identified in the spectral search are viewed while the EUT azimuth angle is varied from 0 to 360 degrees relative to the receiving antenna. The azimuth, which results in the highest emission is then maintained while varying the antenna height from one to four meters (for measurements above 30 MHz, measurements below 30 MHz are made with the loop antenna at a fixed height of 1m). The result is the identification of the highest amplitude for each of the highest peaks. Each recorded level is corrected in the receiver using appropriate factors for cables, connectors, antennas, and preamplifier gain.

When testing above 18 GHz, the receive antenna is located at 1meter from the EUT and the antenna height is restricted to a maximum of 2.5 meters.

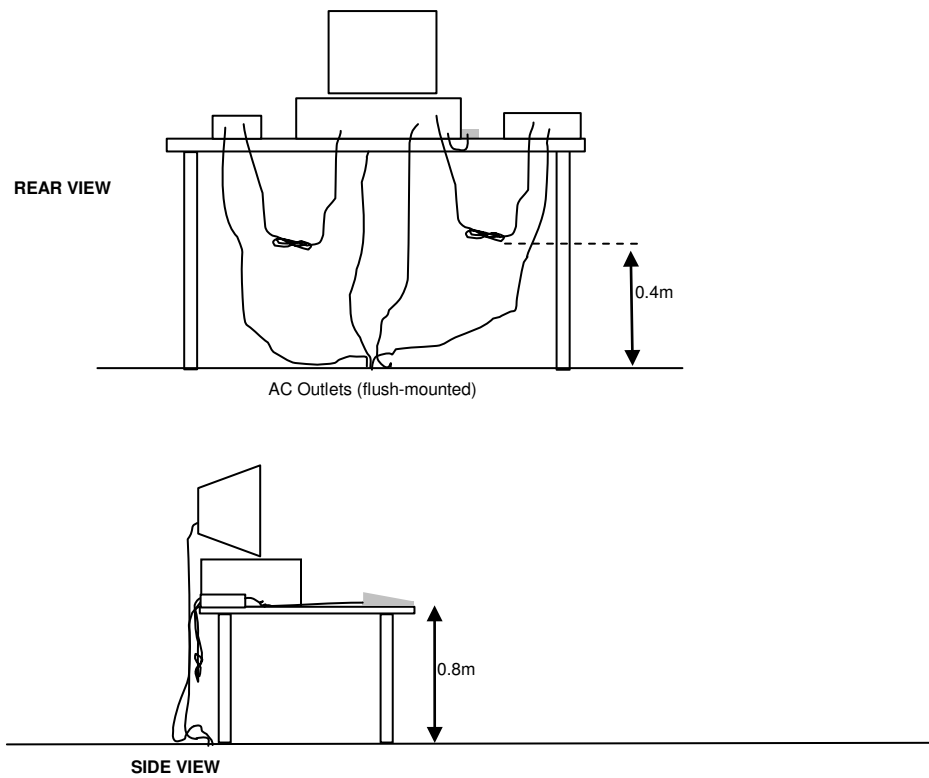

Typical Test Configuration for Radiated Field Strength Measurements



**CONDUCTED EMISSIONS FROM ANTENNA PORT**

Direct measurements of power, bandwidth and power spectral density are performed, where possible, with the antenna port of the EUT connected to either the power meter or spectrum analyzer via a suitable attenuator and/or filter. These are used to ensure that the front end of the measurement instrument is not overloaded by the fundamental transmission.

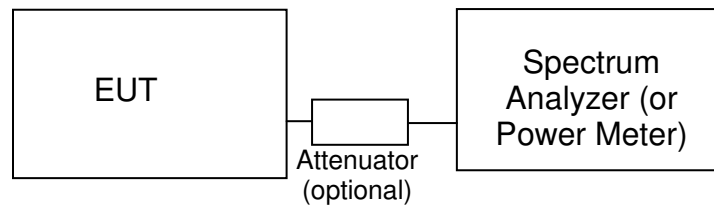
Test Configuration for Antenna Port Measurements

Measurement bandwidths (video and resolution) are set in accordance with the relevant standards and NTS Silicon Valley's test procedures for the type of radio being tested. When power measurements are made using a resolution bandwidth less than the signal bandwidth the power is calculated by summing the power across the signal bandwidth using either the analyzer channel power function or by capturing the trace data and calculating the power using software. In both cases the summed power is corrected to account for the equivalent noise bandwidth (ENBW) of the resolution bandwidth used.

If power averaging is used (typically for certain digital modulation techniques), the EUT is configured to transmit continuously. Power averaging is performed using either the built-in function of the analyzer or, if the analyzer does not feature power averaging, using external software. In both cases the average power is calculated over a number of sweeps (typically 100). When the EUT cannot be configured to continuously transmit then either the analyzer is configured to perform a gated sweep to ensure that the power is averaged over periods that the device is transmitting or power averaging is disabled and a max-hold feature is used.

If a power meter is used to make output power measurements the sensor head type (peak or average) is stated in the test data table.

**BANDWIDTH MEASUREMENTS**

The 6dB, 20dB, 26dB and/or 99% signal bandwidth are measured using the bandwidths recommended by ANSI C63.10 and RSS GEN.

**SPECIFICATION LIMITS AND SAMPLE CALCULATIONS**

The limits for conducted emissions are given in units of microvolts, and the limits for radiated emissions are given in units of microvolts per meter at a specified test distance. Data is measured in the logarithmic form of decibels relative to one microvolt, or dB microvolts (dBuV). For radiated emissions, the measured data is converted to the field strength at the antenna in dB microvolts per meter (dBuV/m). The results are then converted to the linear forms of uV and uV/m for comparison to published specifications.

For reference, converting the specification limits from linear to decibel form is accomplished by taking the base ten logarithm, then multiplying by 20. These limits in both linear and logarithmic form are as follows:

**CONDUCTED EMISSIONS SPECIFICATION LIMITS: FCC 15.207; FCC 15.107(a), RSS GEN**

The table below shows the limits for the emissions on the AC power line from an intentional radiator and a receiver.

Frequency (MHz)	Average Limit (dBuV)	Quasi Peak Limit (dBuV)
0.150 to 0.500	Linear decrease on logarithmic frequency axis between 56.0 and 46.0	Linear decrease on logarithmic frequency axis between 66.0 and 56.0
0.500 to 5.000	46.0	56.0
5.000 to 30.000	50.0	60.0

### **GENERAL TRANSMITTER RADIATED EMISSIONS SPECIFICATION LIMITS**

The table below shows the limits for the spurious emissions from transmitters that fall in restricted bands<sup>1</sup>.

Frequency Range (MHz)	Limit (uV/m)	Limit (dBuV/m @ 3m)
0.009-0.490	2400/F <sub>KHz</sub> @ 300m	67.6-20*log <sub>10</sub> (F <sub>KHz</sub> ) @ 300m
0.490-1.705	24000/F <sub>KHz</sub> @ 30m	87.6-20*log <sub>10</sub> (F <sub>KHz</sub> ) @ 30m
1.705 to 30	30 @ 30m	29.5 @ 30m
30 to 88	100 @ 3m	40 @ 3m
88 to 216	150 @ 3m	43.5 @ 3m
216 to 960	200 @ 3m	46.0 @ 3m
Above 960	500 @ 3m	54.0 @ 3m

### **OUTPUT POWER LIMITS – DIGITAL TRANSMISSION SYSTEMS**

The table below shows the limits for output power and output power density.

Operating Frequency (MHz)	Output Power	Power Spectral Density
2400 – 2483.5	1 Watt (30 dBm)	8 dBm/3kHz

The maximum permitted output power is reduced by 1dB for every dB the antenna gain exceeds 6dBi.

### **TRANSMIT MODE SPURIOUS RADIATED EMISSIONS LIMITS – FHSS and DTS SYSTEMS**

The limits for unwanted (spurious) emissions from the transmitter falling in the restricted bands are those specified in the general limits sections of FCC Part 15 and RSS 210. All other unwanted (spurious) emissions shall be at least 20dB below the level of the highest in-band signal level (30dB if the power is measured using the sample detector/power averaging method).

<sup>1</sup> The restricted bands are detailed in FCC 15.205 and RSS-Gen Table 6

**SAMPLE CALCULATIONS - CONDUCTED EMISSIONS**

Receiver readings are compared directly to the conducted emissions specification limit (decibel form) as follows:

$$R_r - S = M$$

where:

$R_r$  = Receiver Reading in dBuV

$S$  = Specification Limit in dBuV

$M$  = Margin to Specification in +/- dB

**SAMPLE CALCULATIONS - RADIATED EMISSIONS**

Receiver readings are compared directly to the specification limit (decibel form). The receiver internally corrects for cable loss, preamplifier gain, and antenna factor. The calculations are in the reverse direction of the actual signal flow, thus cable loss is added and the amplifier gain is subtracted. The Antenna Factor converts the voltage at the antenna coaxial connector to the field strength at the antenna elements.

A distance factor, when used for electric field measurements above 30MHz, is calculated by using the following formula:

$$F_d = 20 * \text{LOG}_{10} (D_m/D_s)$$

where:

$F_d$  = Distance Factor in dB

$D_m$  = Measurement Distance in meters

$D_s$  = Specification Distance in meters

For electric field measurements below 30MHz the extrapolation factor is either determined by making measurements at multiple distances or a theoretical value is calculated using the formula:

$$F_d = 40 * \text{LOG}_{10} (D_m/D_s)$$

Measurement Distance is the distance at which the measurements were taken and Specification Distance is the distance at which the specification limits are based. The antenna factor converts the voltage at the antenna coaxial connector to the field strength at the antenna elements.

The margin of a given emission peak relative to the limit is calculated as follows:

$$R_c = R_r + F_d$$

and

$$M = R_c - L_s$$

where:

$R_r$  = Receiver Reading in dBuV/m

$F_d$  = Distance Factor in dB

$R_c$  = Corrected Reading in dBuV/m

$L_s$  = Specification Limit in dBuV/m

$M$  = Margin in dB Relative to Spec

**SAMPLE CALCULATIONS - FIELD STRENGTH TO EIRP CONVERSION**

Where the radiated electric field strength is expressed in terms of the equivalent isotropic radiated power (eirp), or where a field strength measurement of output power is made in lieu of a direct measurement, the following formula is used to convert between eirp and field strength at a distance of d (meters) from the equipment under test:

$$E = \frac{1000000 \sqrt{30 P}}{d} \text{ microvolts per meter}$$

where P is the eirp (Watts)

For a measurement at 3m the conversion from a logarithmic value for field strength (dBuV/m) to an eirp power (dBm) is -95.3dB.

## Appendix A Test Equipment Calibration Data

<u>Manufacturer</u>	<u>Description</u>	<u>Model</u>	<u>Asset #</u>	<u>Calibrated</u>	<u>Cal Due</u>
<b>Radiated Spurious Emissions, 1000 - 18,000 MHz, 03-Jun-16</b>					
NTS	NTS EMI Software (rev 2.10)	N/A	0		N/A
NTS	NTS Capture Analyzer Software (rev 3.8)	N/A	0		N/A
EMCO	Antenna, Horn, 1-18GHz	3115	868	6/26/2014	6/26/2016
Hewlett Packard	Microwave Preamplifier, 1-26.5GHz	8449B	1780	10/9/2015	10/9/2016
Micro-Tronics	Band Reject Filter, 2400-2500 MHz	BRM50702-02	2238	9/16/2015	9/16/2016
Hewlett Packard	Spectrum Analyzer (SA40) Purple 9 kHz - 40 GHz,	8564E (84125C)	2415	3/19/2016	3/19/2017
<b>Radiated Spurious Emissions, 1000 - 25,000 MHz, 03-Jun-16</b>					
HP / Miteq	SA40 Head (Purple)	TTA1840-45-5P-HG-S	1772	12/21/2015	12/21/2016
A. H. Systems	Spare System Horn, 18-40GHz	SAS-574, p/n: 2581	2162	7/29/2015	7/29/2017
NTS	NTS EMI Software (rev 2.10)	N/A	0		N/A
NTS	NTS Capture Analyzer Software (rev 3.8)	N/A	0		N/A
EMCO	Antenna, Horn, 1-18GHz	3115	868	6/26/2014	6/26/2016
Hewlett Packard	Microwave Preamplifier, 1-26.5GHz	8449B	1780	10/9/2015	10/9/2016
Micro-Tronics	Band Reject Filter, 2400-2500 MHz	BRM50702-02	2238	9/16/2015	9/16/2016
Hewlett Packard	Spectrum Analyzer (SA40) Purple 9 kHz - 40 GHz,	8564E (84125C)	2415	3/19/2016	3/19/2017
<b>Radiated Spurious Emissions, 1000 - 18,000 MHz, 06-Jun-16</b>					
NTS	NTS EMI Software (rev 2.10)	N/A	0		N/A
EMCO	Antenna, Horn, 1-18GHz	3115	868	6/26/2014	6/26/2016
Hewlett Packard	Microwave Preamplifier, 1-26.5GHz	8449B	1780	10/9/2015	10/9/2016
Micro-Tronics	Band Reject Filter, 2400-2500 MHz	BRM50702-02	2238	9/16/2015	9/16/2016
Hewlett Packard	Spectrum Analyzer (SA40) Purple 9 kHz - 40 GHz,	8564E (84125C)	2415	3/19/2016	3/19/2017
<b>Radiated Emissions, 1000 - 18,000 MHz, 14-Jun-16</b>					
EMCO	Antenna, Horn, 1-18 GHz (SA40-Blu)	3115	1386	10/3/2014	10/3/2016
Hewlett Packard	Microwave Preamplifier, 1-26.5GHz	8449B	1780	10/9/2015	10/9/2016
Micro-Tronics	Band Reject Filter, 2400-2500 MHz	BRM50702-02	2238	9/16/2015	9/16/2016
Hewlett Packard	Spectrum Analyzer (SA40) Purple 9 kHz - 40 GHz,	8564E (84125C)	2415	3/19/2016	3/19/2017
<b>Radiated Spurious Emissions, 1000 - 18,000 MHz, 15-Jun-16</b>					
NTS	NTS EMI Software (rev 2.10)	N/A	0		N/A
EMCO	Antenna, Horn, 1-18 GHz (SA40-Blu)	3115	1386	10/3/2014	10/3/2016
Hewlett Packard	Microwave Preamplifier, 1-26.5GHz	8449B	1780	10/9/2015	10/9/2016

<u>Manufacturer</u>	<u>Description</u>	<u>Model</u>	<u>Asset #</u>	<u>Calibrated</u>	<u>Cal Due</u>
Micro-Tronics	Band Reject Filter, 2400-2500 MHz	BRM50702-02	2238	9/16/2015	9/16/2016
Hewlett Packard	Spectrum Analyzer (SA40) Purple 9 kHz - 40 GHz,	8564E (84125C)	2415	3/19/2016	3/19/2017
<b>Radiated Emissions, 1000 - 25,000 MHz, 29-Jun-16</b>					
Hewlett Packard	Microwave Preamplifier, 1-26.5GHz	8449B	785	10/12/2015	10/12/2016
EMCO	Antenna, Horn, 1-18 GHz (SA40-Blu)	3115	1386	10/3/2014	10/3/2016
HP / Miteq	SA40 Head (Purple)	TTA1840-45-5P-HG-S	1772	12/21/2015	N/A
A. H. Systems	Spare System Horn, 18-40GHz	SAS-574, p/n: 2581	2162	7/29/2015	7/29/2017
Micro-Tronics	Band Reject Filter, 2400-2500 MHz	BRM50702-02	2249	9/16/2015	9/16/2016
Hewlett Packard	Spectrum Analyzer (SA40) Purple 9 kHz - 40 GHz,	8564E (84125C)	2415	3/19/2016	3/19/2017
<b>Radiated Emissions, 30 - 1,000 MHz, 30-Jun-16</b>					
Rohde & Schwarz	EMI Test Receiver, 20 Hz-7 GHz	ESIB7	1538	12/19/2015	12/19/2016
Sunol Sciences	Biconilog, 30-3000 MHz	JB3	1549	6/2/2015	6/2/2017
Micro-Tronics	Band Reject Filter, 2400-2500 MHz	BRM50702-02	2238	9/16/2015	9/16/2016
Hewlett Packard	9KHz-1300MHz pre-amp	8447F	2777	1/26/2016	1/26/2017
<b>Radiated Emissions, 1000 - 6,000 MHz, 30-Jun-16</b>					
EMCO	Antenna, Horn, 1-18 GHz (SA40-Blu)	3115	1386	10/3/2014	10/3/2016
Rohde & Schwarz	EMI Test Receiver, 20 Hz-7 GHz	ESIB7	1538	12/19/2015	12/19/2016
<b>Conducted Emissions - AC Power Ports, 01-Jul-16</b>					
EMCO	LISN, 10 kHz-100 MHz	3825/2	1293	6/7/2016	6/7/2017
Rohde & Schwarz	EMI Test Receiver, 20 Hz-7 GHz	ESIB7	1538	12/19/2015	12/19/2016
Rohde & Schwarz	Pulse Limiter	ESH3 Z2	1594	5/5/2016	5/5/2017
<b>Radiated Emissions, 1000 - 18,000 MHz, 01-Jul-16</b>					
EMCO	Antenna, Horn, 1-18 GHz (SA40-Blu)	3115	1386	10/3/2014	10/3/2016
Hewlett Packard	Microwave Preamplifier, 1-26.5GHz	8449B	1780	10/9/2015	10/9/2016
Micro-Tronics	Band Reject Filter, 2400-2500 MHz	BRM50702-02	2238	9/16/2015	9/16/2016
Hewlett Packard	Spectrum Analyzer (SA40) Purple 9 kHz - 40 GHz,	8564E (84125C)	2415	3/19/2016	3/19/2017
<b>Radiated Spurious Emissions, 1000 - 18,000 MHz, 05-Jul-16</b>					
NTS	NTS EMI Software (rev 2.10)	N/A	0		N/A
EMCO	Antenna, Horn, 1-18 GHz (SA40-Blu)	3115	1386	10/3/2014	10/3/2016
Hewlett Packard	Microwave Preamplifier, 1-26.5GHz	8449B	1780	10/9/2015	10/9/2016
Micro-Tronics	Band Reject Filter, 2400-2500 MHz	BRM50702-02	2249	9/16/2015	9/16/2016



<u>Manufacturer</u>	<u>Description</u>	<u>Model</u>	<u>Asset #</u>	<u>Calibrated</u>	<u>Cal Due</u>
Hewlett Packard	Spectrum Analyzer (SA40) Purple 9 kHz - 40 GHz,	8564E (84125C)	2415	3/19/2016	3/19/2017
<b>Radio Antenna Port, 05-Jul-16 and 25-Jul-16</b>					
Rohde & Schwarz	Signal Analyzer 20 Hz - 26.5 GHz	FSQ26	2327	6/17/2016	6/17/2017
Rohde & Schwarz	Open Switch and Control Unit, p/s	OSP120 with B157	3000	6/16/2016	6/16/2017
<b>Radiated Emissions, 1000 - 18,000 MHz, 07-Jul-16</b>					
EMCO	Antenna, Horn, 1-18 GHz (SA40-Blu)	3115	1386	10/3/2014	10/3/2016
Hewlett Packard	Microwave Preamplifier, 1- 26.5GHz	8449B	1780	10/9/2015	10/9/2016
Micro-Tronics	Band Reject Filter, 2400-2500 MHz	BRM50702-02	2249	9/16/2015	9/16/2016
Hewlett Packard	Spectrum Analyzer (SA40) Purple 9 kHz - 40 GHz,	8564E (84125C)	2415	3/19/2016	3/19/2017



## **Appendix B Test Data**

T101935 Pages 26 – 55



## EMC Test Data

Client:	Fitbit, Inc.	Job Number:	JD101921
Product:	FB403	T-Log Number:	T101935
System Configuration:	-	Project Manager:	Deepa Shetty
Contact:	Sachin Sawalapurkar	Project Coordinator:	-
Emissions Standard(s):	FCC 15.247, RSS-247, LP0002	Class:	-
Immunity Standard(s):	-	Environment:	-

# EMC Test Data

For The

## Fitbit, Inc.

Product

### FB403

Date of Last Test: 7/8/2016

Client: Fitbit, Inc.	Job Number: JD101921
Model: FB403	T-Log Number: T101935
	Project Manager: Deepa Shetty
Contact: Sachin Sawalapurkar	Project Coordinator: -
Standard: FCC 15.247, RSS-247, LP0002	Class: N/A

## Duty Cycle

Date of Test: 6/3/2016  
 Test Engineer: John Caizzi  
 Test Location: Chamber 7

Notes: Measurements taken with maximum RBW/VBW settings allowed.

Mode	Data Rate	Duty Cycle (x)	Constant DC?	T (ms)	Pwr Cor Factor*	Lin Volt Cor Factor**	Min VBW for FS (Hz)
BLE	1 Mbps	63.0%	Yes	0.39	2.01	4.01	2538

\* Correction factor when using RMS/Power averaging -  $10 \cdot \log(1/x)$

\*\* Correction factor when using linear voltage average -  $20 \cdot \log(1/x)$

T = Minimum transmission duration

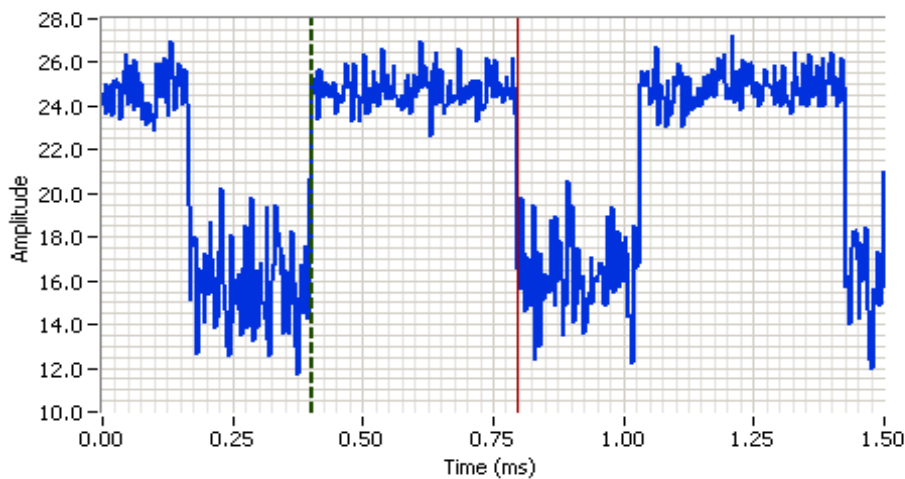

### Analyzer Settings

Rohde&Schwarz,ESI  
 CF: 2480.000 MHz  
 SPAN: 0.000 MHz  
 RB: 10.000 MHz  
 VB: 10.000 MHz  
 Detector: POS  
 Attn: 0 DB  
 RL Offset: 0.0 DB  
 Sweep Time: 1.5ms  
 Ref Lvl: 35.0 DBUV

### Comments

On time = .394 ms

Cursor 1	0.4021	29.1	
Cursor 2	0.7964	29.4	

Delta Time (ms)	0.394
Delta Amplitude	0.3

Client: Fitbit, Inc.	Job Number: JD101921
Model: FB403	T-Log Number: T101935
Contact: Sachin Sawalapurkar	Project Manager: Deepa Shetty
Standard: FCC 15.247, RSS-247, LP0002	Project Coordinator: -
	Class: N/A

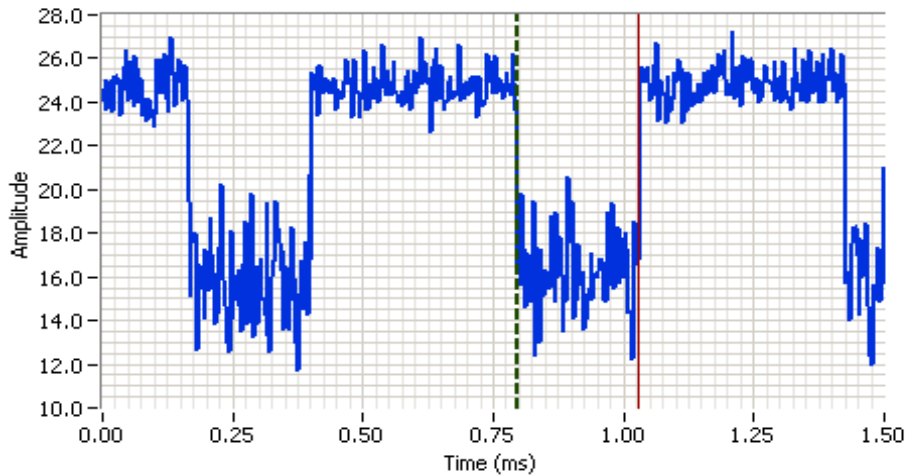

**Analyzer Settings**

Rohde&Schwarz,ESI  
 CF: 2480.000 MHz  
 SPAN: 0.000 MHz  
 RB: 10.000 MHz  
 VB: 10.000 MHz  
 Detector: POS  
 Attn: 0 DB  
 RL Offset: 0.0 DB  
 Sweep Time: 1.5ms  
 Ref Lvl: 35.0 DBUV

**Comments**

Off time = .232 ms

Cursor 1	0.7964	29.1		Delta Time (ms)	0.232
Cursor 2	1.0284	29.4		Delta Amplitude	0.3



# EMC Test Data

Client: Fitbit, Inc.	Job Number: JD101921
Model: FB403	T-Log Number: T101935
	Project Manager: Deepa Shetty
Contact: Sachin Sawalapurkar	Project Coordinator: -
Standard: FCC 15.247, RSS-247, LP0002	Class: N/A

## RSS-247 and FCC 15.247 (DTS) Radiated Spurious Emissions

### Test Specific Details

Objective: The objective of this test session is to perform final qualification testing of the EUT with respect to the specification listed above.

### General Test Configuration

The EUT and all local support equipment were located on the turntable for radiated spurious emissions testing.

For radiated emissions testing the measurement antenna was located 3 meters from the EUT, unless otherwise noted.

### Ambient Conditions:

Temperature: 22.3 °C  
Rel. Humidity: 34 %

### Summary of Results - Device Operating in the 2400-2483.5 MHz Band

Run #	Mode	Channel	Target Power	Power Setting	Test Performed	Limit	Result / Margin
1	BLE	0 2402MHz	13	13	Radiated Emissions, 1 - 25 GHz	FCC Part 15.209 / 15.247( c)	46.6 dBµV/m @ 12008.9 MHz (-7.4 dB)
		19 2440 MHz	13				47.8 dBµV/m @ 12198.8 MHz (-6.2 dB)
		39 2480MHz	13				48.2 dBµV/m @ 12398.8 MHz (-5.8 dB)

### Modifications Made During Testing

No modifications were made to the EUT during testing

### Deviations From The Standard

No deviations were made from the requirements of the standard.

### Sample Notes

Sample S/N: 0x180b9126b042 (EVT2-01)

Driver: 24.08, build 0x00000001, compiled 5/18/16

Antenna: internal

The EUT can be installed into various enclosures; metal bangle (wrist worn), metal pendant, and plastic clip-on. Spurious emissions were assessed in these enclosures and compared to the results from the EUT mounted in the charging fixture. The results from the charging fixture are presented here, as they represent the worse case.

Client: Fitbit, Inc.	Job Number: JD101921
Model: FB403	T-Log Number: T101935
	Project Manager: Deepa Shetty
Contact: Sachin Sawalapurkar	Project Coordinator: -
Standard: FCC 15.247, RSS-247, LP0002	Class: N/A

### Procedure Comments:

Measurements performed in accordance with FCC KDB 558074

Peak measurements performed with: RBW=1MHz, VBW=3MHz, peak detector, max hold, auto sweep time

Unless otherwise stated/noted, emission has duty cycle  $\geq 98\%$  and was measured using RBW=1MHz, VBW=10Hz, peak detector, linear average mode, auto sweep time, max hold.

2.4GHz band reject filter used

Mode	Data Rate	Duty Cycle (x)	Constant DC?	T (ms)	Pwr Cor Factor*	Lin Volt Cor Factor**	Min VBW for FS (Hz)
BLE	1Mb/s	0.63	Yes	0.394	2.01	4.02	2538

### Measurement Specific Notes:

Note 1:	Emission in non-restricted band, but limit of 15.209 used.
Note 2:	Emission in non-restricted band, the limit was set 30dB below the level of the fundamental and measured in 100kHz.
Note 4:	Emission has constant duty cycle $< 98\%$ , average measurement performed: RBW=1MHz, VBW $> 1/T$ but not less than 10Hz, peak detector, linear averaging, auto sweep, trace average 100 traces, measurement corrected by Linear voltage correction factor
Note 6:	Emission has non constant duty cycle $< 98\%$ , average measurement performed: RBW=1MHz, VBW $> 1/T$ , peak detector, linear average mode, sweep time auto, max hold. Max hold for $50*(1/DC)$ traces



# EMC Test Data

Client: Fitbit, Inc.	Job Number: JD101921
Model: FB403	T-Log Number: T101935
Contact: Sachin Sawalapurkar	Project Manager: Deepa Shetty
Standard: FCC 15.247, RSS-247, LP0002	Project Coordinator: -
	Class: N/A

## Run #1: Radiated Spurious Emissions, 1,000 - 25000 MHz. Operating Mode: BLE

Date of Test: 6/29/2016 0:00  
 Test Engineer: Rafael Varelas  
 Test Location: Chamber #7

Config. Used: 1  
 Config Change: none  
 EUT Voltage: 120V / 60Hz

### Run #1a: Low Channel (EUT Side)

Channel: 0 Mode: BLE  
 Tx Chain: NA Data Rate: 1Mb/s

Frequency	Level	Pol	15.209 / 15.247		Detector	Azimuth	Height	Comments
MHz	dB $\mu$ V/m	v/h	Limit	Margin	Pk/QP/Avg	degrees	meters	
4803.690	43.2	H	54.0	-10.8	Vavg	93	1.4	Note 4, RB 1 MHz;VB 3 kHz;Peak
4804.460	48.3	H	74.0	-25.7	PK	93	1.4	RB 1 MHz;VB 3 MHz;Peak
4803.750	42.4	V	54.0	-11.6	Vavg	21	1.1	Note 4, RB 1 MHz;VB 3 kHz;Peak
4803.420	47.7	V	74.0	-26.3	PK	21	1.1	RB 1 MHz;VB 3 MHz;Peak
12008.850	45.9	H	54.0	-8.1	Vavg	133	1.0	Note 4, RB 1 MHz;VB 3 kHz;Peak
12011.310	53.4	H	74.0	-20.6	PK	133	1.0	RB 1 MHz;VB 3 MHz;Peak
12008.860	46.6	V	54.0	-7.4	Vavg	112	1.0	Note 4, RB 1 MHz;VB 3 kHz;Peak
12010.710	54.3	V	74.0	-19.7	PK	112	1.0	RB 1 MHz;VB 3 MHz;Peak

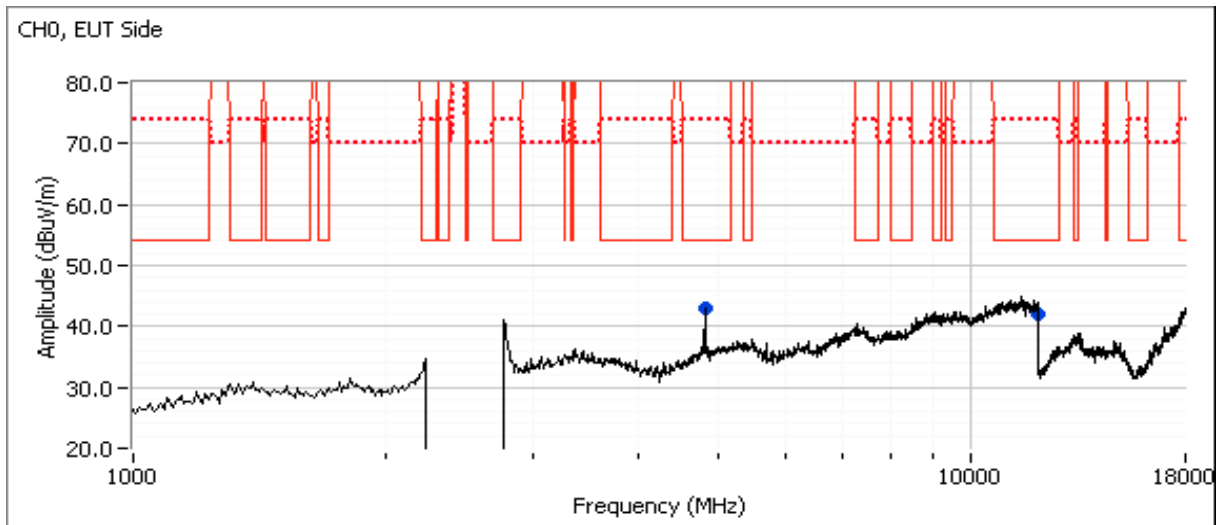



# EMC Test Data

Client: Fitbit, Inc.	Job Number: JD101921
Model: FB403	T-Log Number: T101935
Contact: Sachin Sawalapurkar	Project Manager: Deepa Shetty
Standard: FCC 15.247, RSS-247, LP0002	Project Coordinator: -
	Class: N/A

## Run #1b: Center Channel (All orientations evaluated)

Channel: 19                      Mode: BLE  
 Tx Chain: NA                    Data Rate: 1Mb/s

Frequency	Level	Pol	15.209 / 15.247		Detector	Azimuth	Height	Comments
MHz	dB $\mu$ V/m	v/h	Limit	Margin	PK/QP/Avg	degrees	meters	
<b>EUT Flat</b>								
4879.790	45.6	H	54.0	-8.4	Vavg	128	1.17	Note 4, RB 1 MHz;VB 3 kHz;Peak
4880.540	49.8	H	74.0	-24.2	PK	128	1.17	RB 1 MHz;VB 3 MHz;Peak
4879.590	37.8	V	54.0	-16.2	Vavg	26	1.00	Note 4, RB 1 MHz;VB 3 kHz;Peak
4880.850	45.1	V	74.0	-28.9	PK	26	1.00	RB 1 MHz;VB 3 MHz;Peak
12198.770	46.8	V	54.0	<b>-7.2</b>	Vavg	235	1.00	Note 4, RB 1 MHz;VB 3 kHz;Peak
12201.060	54.5	V	74.0	-19.5	PK	235	1.00	RB 1 MHz;VB 3 MHz;Peak
12198.850	46.5	H	54.0	-7.5	Vavg	116	1.04	Note 4, RB 1 MHz;VB 3 kHz;Peak
12198.850	53.9	H	74.0	-20.1	PK	116	1.04	RB 1 MHz;VB 3 MHz;Peak
<b>EUT Side</b>								
4879.870	44.9	H	54.0	-9.1	Vavg	94	1.06	Note 4, RB 1 MHz;VB 3 kHz;Peak
4880.560	50.1	H	74.0	-23.9	PK	94	1.06	RB 1 MHz;VB 3 MHz;Peak
4879.670	43.4	V	54.0	-10.6	Vavg	29	1.00	Note 4, RB 1 MHz;VB 3 kHz;Peak
4879.770	48.7	V	74.0	-25.3	PK	29	1.00	RB 1 MHz;VB 3 MHz;Peak
12198.840	47.8	V	54.0	<b>-6.2</b>	Vavg	55	1.04	Note 4, RB 1 MHz;VB 3 kHz;Peak
12201.160	55.4	V	74.0	-18.6	PK	55	1.04	RB 1 MHz;VB 3 MHz;Peak
12198.720	46.0	H	54.0	-8.0	Vavg	133	1.00	Note 4, RB 1 MHz;VB 3 kHz;Peak
12201.380	53.4	H	74.0	-20.6	PK	133	1.00	RB 1 MHz;VB 3 MHz;Peak
<b>EUT Upright</b>								
4879.870	44.9	V	54.0	-9.1	Vavg	125	1.91	Note 4, RB 1 MHz;VB 3 kHz;Peak
4879.500	49.2	V	74.0	-24.8	PK	125	1.91	RB 1 MHz;VB 3 MHz;Peak
4879.630	41.9	H	54.0	-12.1	Vavg	126	1.24	Note 4, RB 1 MHz;VB 3 kHz;Peak
4879.450	47.0	H	74.0	-27.0	PK	126	1.24	RB 1 MHz;VB 3 MHz;Peak
12198.760	46.4	H	54.0	<b>-7.6</b>	Vavg	113	1.00	Note 4, RB 1 MHz;VB 3 kHz;Peak
12201.180	54.3	H	74.0	-19.7	PK	113	1.00	RB 1 MHz;VB 3 MHz;Peak
12198.750	45.5	V	54.0	-8.5	Vavg	268	1.00	Note 4, RB 1 MHz;VB 3 kHz;Peak
12200.810	52.8	V	74.0	-21.2	PK	268	1.00	RB 1 MHz;VB 3 MHz;Peak

Note: Scans made between 18 - 25 GHz with the measurement antenna moved around the card and its antennas 20-50cm from the device indicated there were no significant emissions in this frequency range



Client: Fitbit, Inc.	Job Number: JD101921
Model: FB403	T-Log Number: T101935
	Project Manager: Deepa Shetty
Contact: Sachin Sawalapurkar	Project Coordinator: -
Standard: FCC 15.247, RSS-247, LP0002	Class: N/A

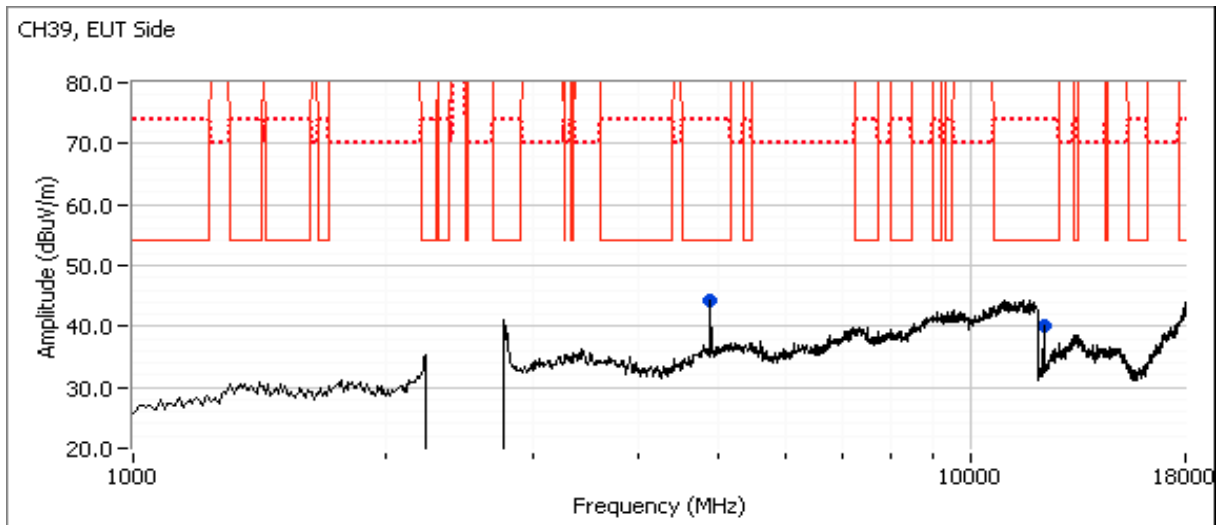
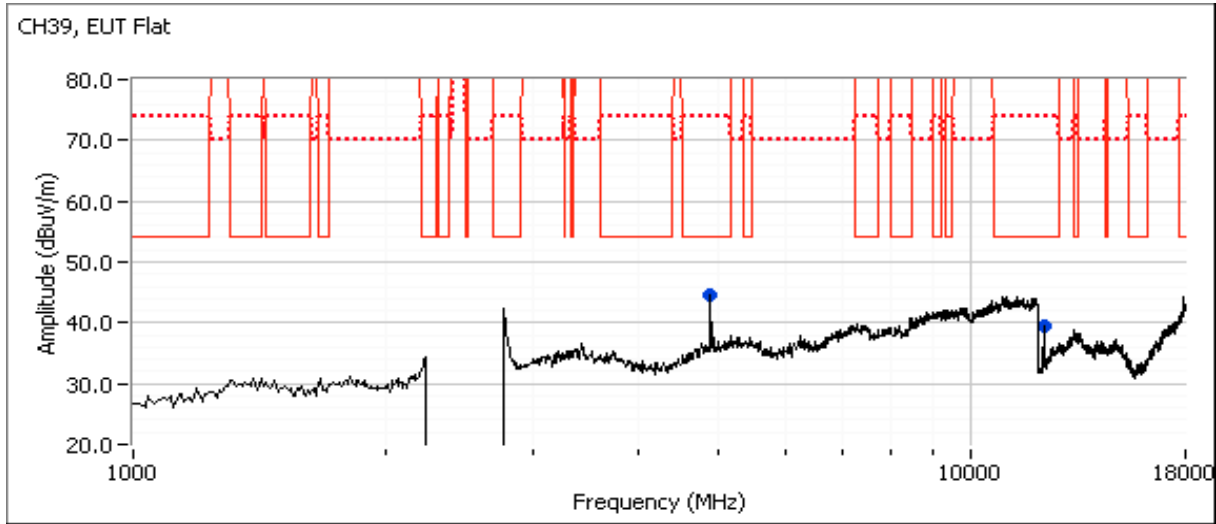

Client: Fitbit, Inc.	Job Number: JD101921
Model: FB403	T-Log Number: T101935
	Project Manager: Deepa Shetty
Contact: Sachin Sawalapurkar	Project Coordinator: -
Standard: FCC 15.247, RSS-247, LP0002	Class: N/A

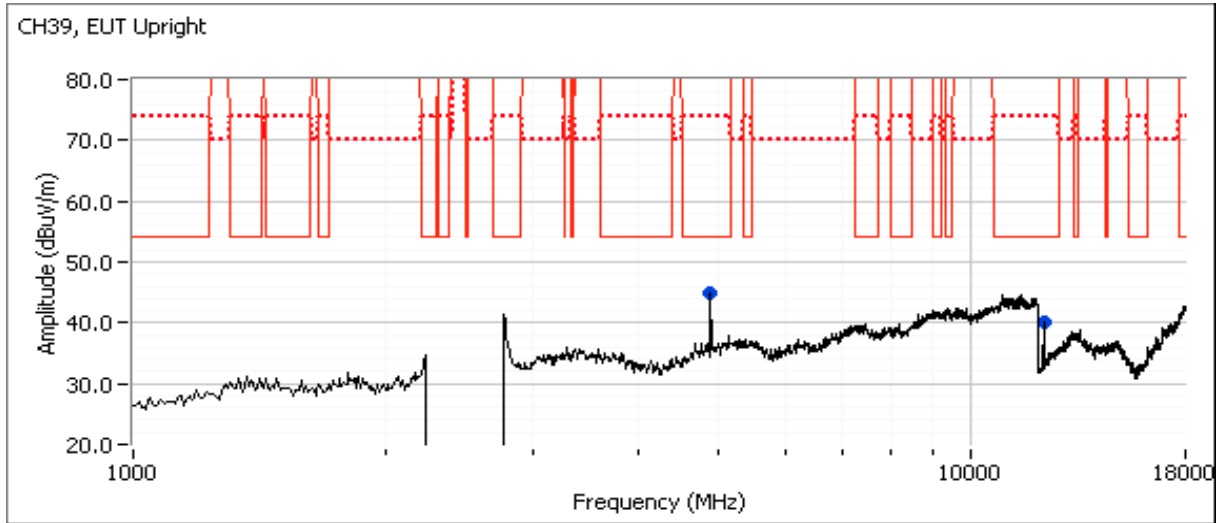

Client: Fitbit, Inc.	Job Number: JD101921
Model: FB403	T-Log Number: T101935
Contact: Sachin Sawalapurkar	Project Manager: Deepa Shetty
Standard: FCC 15.247, RSS-247, LP0002	Project Coordinator: -
	Class: N/A

### Run #1c: High Channel (EUT Side)

Channel: 39                      Mode: BLE  
 Tx Chain: NA                    Data Rate: 1Mb/s

Frequency	Level	Pol	15.209 / 15.247		Detector	Azimuth	Height	Comments
MHz	dB $\mu$ V/m	v/h	Limit	Margin	Pk/QP/Avg	degrees	meters	
4959.830	47.5	H	54.0	-6.5	Vavg	91	1.3	Note 4, RB 1 MHz;VB 3 kHz;Peak
4960.480	51.3	H	74.0	-22.7	PK	91	1.3	RB 1 MHz;VB 3 MHz;Peak
4959.690	45.7	V	54.0	-8.3	Vavg	24	1.0	Note 4, RB 1 MHz;VB 3 kHz;Peak
4960.420	49.8	V	74.0	-24.2	PK	24	1.0	RB 1 MHz;VB 3 MHz;Peak
12398.770	45.7	H	54.0	-8.3	Vavg	112	1.0	Note 4, RB 1 MHz;VB 3 kHz;Peak
12398.820	53.6	H	74.0	-20.4	PK	112	1.0	RB 1 MHz;VB 3 MHz;Peak
12398.830	48.2	V	54.0	<b>-5.8</b>	Vavg	53	1.0	Note 4, RB 1 MHz;VB 3 kHz;Peak
12398.820	55.1	V	74.0	-18.9	PK	53	1.0	RB 1 MHz;VB 3 MHz;Peak

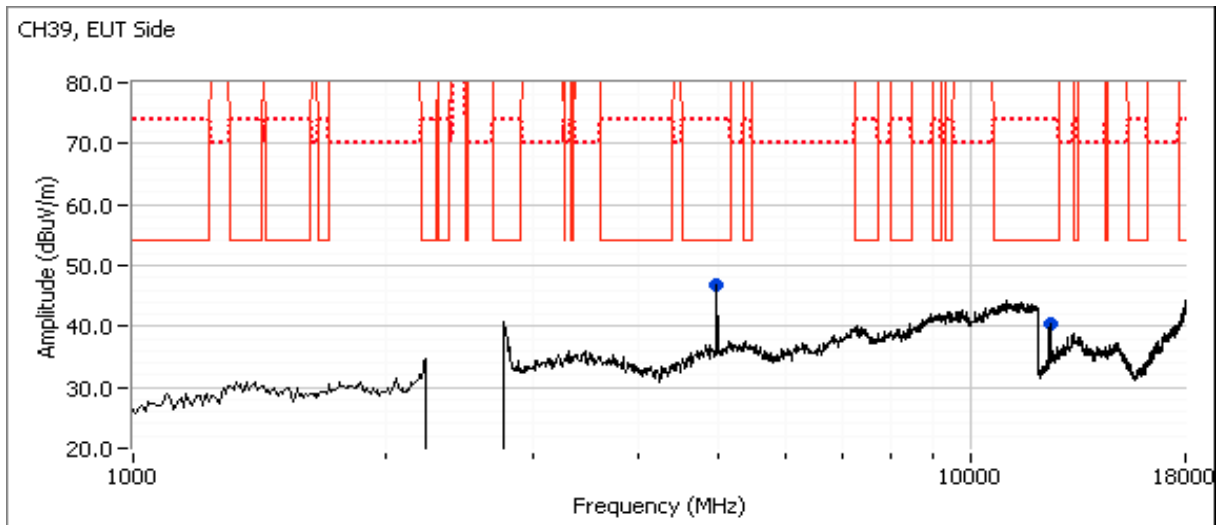



# EMC Test Data

Client: Fitbit, Inc.	Job Number: JD101921
Model: FB403	T-Log Number: T101935
	Project Manager: Deepa Shetty
Contact: Sachin Sawalapurkar	Project Coordinator: -
Standard: FCC 15.247, RSS-247, LP0002	Class: N/A

## RSS-247 and FCC 15.247 (DTS) Radiated Spurious Emissions

### Test Specific Details

Objective: The objective of this test session is to perform final qualification testing of the EUT with respect to the specification listed above.

### General Test Configuration

The EUT and all local support equipment were located on the turntable for radiated spurious emissions testing.

For radiated emissions testing the measurement antenna was located 3 meters from the EUT, unless otherwise noted.

### Ambient Conditions:

Temperature: 22.6 °C  
Rel. Humidity: 35 %

### Summary of Results - Device Operating in the 2400-2483.5 MHz Band

Run #	Mode	Channel	Target Power	Power Setting	Test Performed	Limit	Result / Margin
1	BLE	2402MHz	-	13	Radiated Emissions, 30 - 1000 MHz	FCC Part 15.209 / 15.247(d)	25.8 dBµV/m @ 180.48 MHz (-17.7 dB)
		2480MHz	-				25.5 dBµV/m @ 179.54 MHz (-18.0 dB)

### Modifications Made During Testing

No modifications were made to the EUT during testing

### Deviations From The Standard

No deviations were made from the requirements of the standard.

### Sample Notes

Sample S/N: 0x180b9126b042 (EVT2-01)  
Driver: 24.08, build 0x00000001, compiled 5/18/16  
Antenna: internal

Client: Fitbit, Inc.	Job Number: JD101921
Model: FB403	T-Log Number: T101935
	Project Manager: Deepa Shetty
Contact: Sachin Sawalapurkar	Project Coordinator: -
Standard: FCC 15.247, RSS-247, LP0002	Class: N/A

### Procedure Comments:

Measurements performed in accordance with FCC KDB 558074

Peak measurements performed with: RBW=1MHz, VBW=3MHz, peak detector, max hold, auto sweep time

Unless otherwise stated/noted, emission has duty cycle  $\geq 98\%$  and was measured using RBW=1MHz, VBW=10Hz, peak detector, linear average mode, auto sweep time, max hold.

2.4GHz band reject filter used

Mode	Data Rate	Duty Cycle (x)	Constant DC?	T (ms)	Pwr Cor Factor*	Lin Volt Cor Factor**	Min VBW for FS (Hz)
BLE	1Mb/s	0.63	Yes	0.394	2.01	4.02	2538

### Measurement Specific Notes:

Note 1:	Emission in non-restricted band, but limit of 15.209 used.
Note 2:	Emission in non-restricted band, the limit was set 30dB below the level of the fundamental and measured in 100kHz.
Note 3:	Emission has a duty cycle $\geq 98\%$ , average measurement performed: RBW=1MHz, VBW=3MHz, RMS, Power averaging, auto sweep, trace average 100 traces
Note 4:	Emission has constant duty cycle $< 98\%$ , average measurement performed: RBW=1MHz, VBW $> 1/T$ but not less than 10Hz, peak detector, linear averaging, auto sweep, trace average 100 traces, measurement corrected by Linear voltage correction factor
Note 5:	Emission has constant duty cycle $< 98\%$ , average measurement performed: RBW=1MHz, VBW=3MHz, RMS, Power averaging, auto sweep, trace average 100 traces, measurement corrected by Pwr correction factor
Note 6:	Emission has non constant duty cycle $< 98\%$ , average measurement performed: RBW=1MHz, VBW $> 1/T$ , peak detector, linear average mode, sweep time auto, max hold. Max hold for $50 \cdot (1/DC)$ traces
Note 7:	Emission has non constant duty cycle $< 98\%$ , average measurement performed: RBW=1MHz, VBW $> 1/T$ , RMS detector, sweep time auto, max hold. Max hold for $50 \cdot (1/DC)$ traces

Client: Fitbit, Inc.	Job Number: JD101921
Model: FB403	T-Log Number: T101935
	Project Manager: Deepa Shetty
Contact: Sachin Sawalapurkar	Project Coordinator: -
Standard: FCC 15.247, RSS-247, LP0002	Class: N/A

**Run #1: Radiated Spurious Emissions, 30 - 1000 MHz. Operating Mode: BLE**  
 Date of Test: 6/30/2016 0:00 Config. Used: 1  
 Test Engineer: Rafael Varelas Config Change: none  
 Test Location: Chamber #7 EUT Voltage: 120V / 60Hz

**Run #1a: Low Channel (EUT Side)**

Channel: 2402MHz Mode: BLE  
 Tx Chain: N/A Data Rate: 1Mb/s

Frequency	Level	Pol	15.209 / 15.247		Detector	Azimuth	Height	Comments
MHz	dB $\mu$ V/m	v/h	Limit	Margin	Pk/QP/Avg	degrees	meters	
180.481	25.8	H	43.5	-17.7	QP	270	2.0	Note 1
996.027	23.3	V	54.0	-30.7	QP	44	1.0	
39.836	17.5	V	40.0	-22.5	QP	60	1.0	Note 1
30.680	19.5	V	40.0	-20.5	QP	289	1.0	Note 1

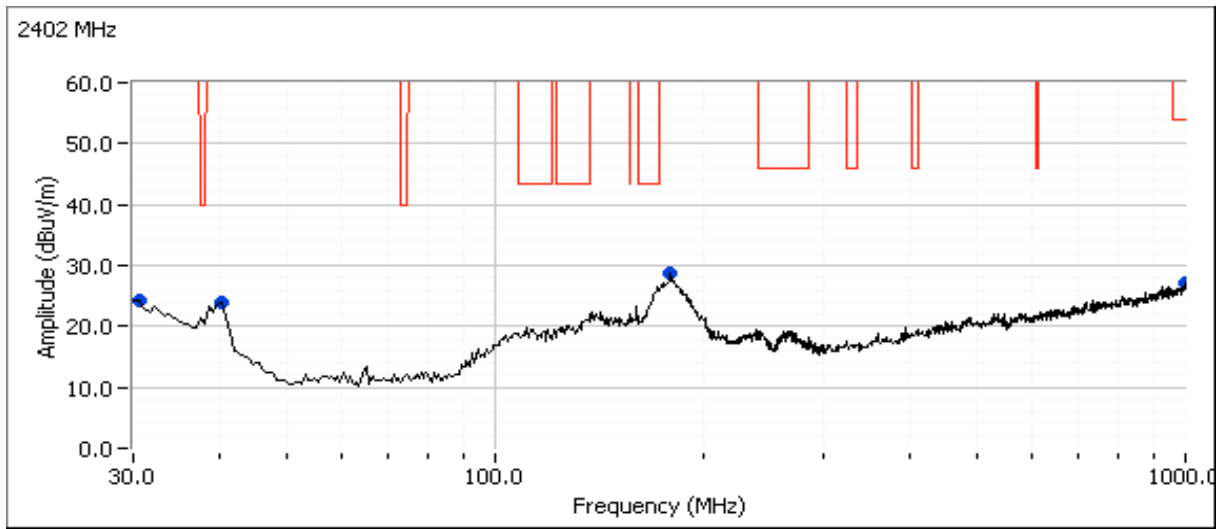

Client: Fitbit, Inc.	Job Number: JD101921
Model: FB403	T-Log Number: T101935
	Project Manager: Deepa Shetty
Contact: Sachin Sawalapurkar	Project Coordinator: -
Standard: FCC 15.247, RSS-247, LP0002	Class: N/A

### Run #1c: High Channel (EUT Side)

Channel: 2480                      Mode: BLE  
 Tx Chain: N/A                      Data Rate: 1Mb/s

Frequency MHz	Level dB $\mu$ V/m	Pol v/h	15.209 / 15.247		Detector Pk/QP/Avg	Azimuth degrees	Height meters	Comments
			Limit	Margin				
179.541	25.5	H	43.5	-18.0	QP	118	2.0	Note 1
992.332	23.3	H	54.0	-30.7	QP	212	1.0	
30.633	19.5	V	40.0	-20.5	QP	179	1.0	Note 1
40.031	18.9	V	40.0	-21.1	QP	141	1.0	Note 1

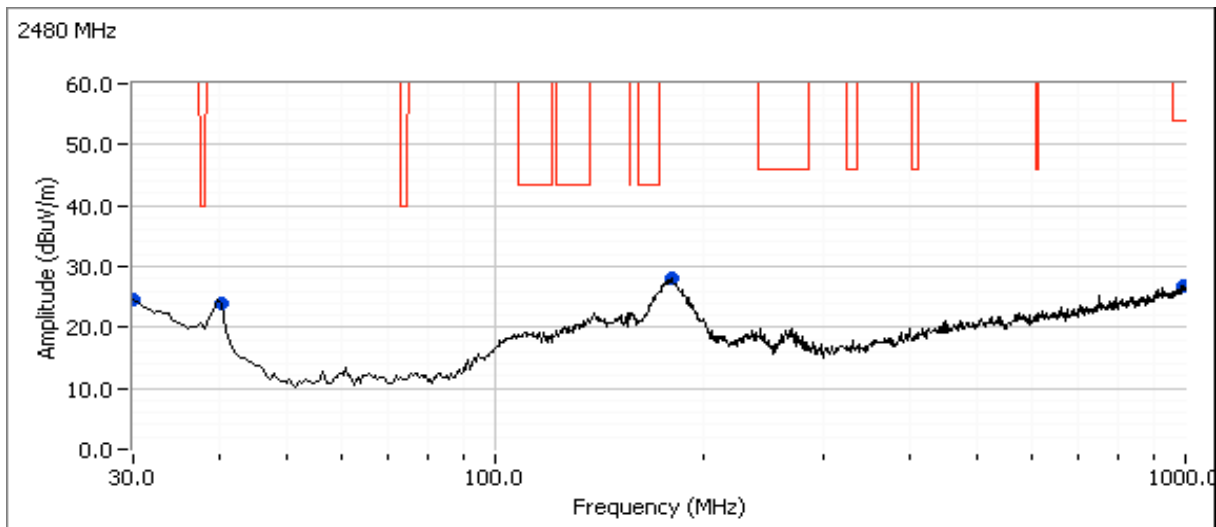



# EMC Test Data

Client: Fitbit, Inc.	Job Number: JD101921
Model: FB403	T-Log Number: T101935
	Project Manager: Deepa Shetty
Contact: Sachin Sawalapurkar	Project Coordinator: -
Standard: FCC 15.247, RSS-247, LP0002	Class: N/A

## RSS-247 and FCC 15.247 (DTS) Radiated Spurious Emissions

### Test Specific Details

Objective: The objective of this test session is to perform final qualification testing of the EUT with respect to the specification listed above.

### General Test Configuration

The EUT and all local support equipment were located on the turntable for radiated spurious emissions testing. For radiated emissions testing the measurement antenna was located 3 meters from the EUT, unless otherwise noted.

### Ambient Conditions:

Temperature: 22.6 °C  
Rel. Humidity: 35 %

### Summary of Results - Device Operating in the 2400-2483.5 MHz Band

Run #	Mode	Channel	Target Power	Power Setting	Test Performed	Limit	Result / Margin
1	BLE	2402MHz	-	13	Restricted Band Edge (2390 MHz)	FCC Part 15.209 / 15.247( c)	37.8 dBµV/m @ 2386.0 MHz (-16.2 dB)
		2480MHz	-	13	Restricted Band Edge (2483.5 MHz)	FCC Part 15.209 / 15.247( c)	65.3 dBµV/m @ 2484.3 MHz (-8.7 dB)

### Modifications Made During Testing

No modifications were made to the EUT during testing

### Deviations From The Standard

No deviations were made from the requirements of the standard.

### Sample Notes

Sample S/N: 0x180b9126b042 (EVT2-01)  
Driver: 24.08, build 0x00000001, compiled 5/18/16  
Antenna: internal



Client: Fitbit, Inc.	Job Number: JD101921
Model: FB403	T-Log Number: T101935
	Project Manager: Deepa Shetty
Contact: Sachin Sawalapurkar	Project Coordinator: -
Standard: FCC 15.247, RSS-247, LP0002	Class: N/A

### Procedure Comments:

Measurements performed in accordance with FCC KDB 558074

Peak measurements performed with: RBW=1MHz, VBW=3MHz, peak detector, max hold, auto sweep time

Unless otherwise stated/noted, emission has a duty cycle  $\geq 98\%$  and was measured using RBW=1MHz, VBW=10Hz, peak detector, linear average mode, auto sweep time, max hold.

Mode	Data Rate	Duty Cycle (x)	Constant DC?	T (ms)	Pwr Cor Factor*	Lin Volt Cor Factor**	Min VBW for FS (Hz)
BLE	1Mb/s	0.63	Yes	0.394	2.01	4.02	2538

### Measurement Specific Notes:

Note 1:	Emission in non-restricted band, but limit of 15.209 used.
Note 2:	Emission in non-restricted band, the limit was set 30dB below the level of the fundamental and measured in 100kHz.
Note 4:	Emission has constant duty cycle $< 98\%$ , average measurement performed: RBW=1MHz, VBW $> 1/T$ but not less than 10Hz, peak detector, linear averaging, auto sweep, trace average 100 traces, measurement corrected by Linear Voltage correction factor
Note 6:	Emission has non constant duty cycle $< 98\%$ , average measurement performed: RBW=1MHz, VBW $> 1/T$ , peak detector, linear average mode, sweep time auto, max hold. Max hold for $50 \cdot (1/DC)$ traces
Note 8:	Plots of the average and peak bandedge do not account for any duty cycle correction. Refer to the tabular results for final measurements.



# EMC Test Data

Client: Fitbit, Inc.	Job Number: JD101921
Model: FB403	T-Log Number: T101935
	Project Manager: Deepa Shetty
Contact: Sachin Sawalapurkar	Project Coordinator: -
Standard: FCC 15.247, RSS-247, LP0002	Class: N/A

## Run #1: Radiated Bandedge Measurements

Date of Test: 6/30/2016 0:00  
 Test Engineer: Rafael Varelas  
 Test Location: Chamber #7

Config. Used: 1  
 Config Change: none  
 EUT Voltage: 120V / 60Hz

Channel: 2402                      Mode: BLE  
 Tx Chain: Main                      Data Rate: 1Mb/s

## Band Edge Signal Field Strength - Direct measurement of field strength

Frequency	Level	Pol	15.209 / 15.247		Detector	Azimuth	Height	Comments
MHz	dBµV/m	v/h	Limit	Margin	Pk/QP/Avg	degrees	meters	
<b>EUT Side</b>								
2386.030	37.8	H	54.0	-16.2	Vavg	31	1.0	Note 4; RB 1 MHz; VB: 3 kHz
2388.110	53.9	H	74.0	-20.1	PK	31	1.0	POS; RB 1 MHz; VB: 3 MHz
2386.120	35.0	V	54.0	-19.0	Vavg	139	1.0	Note 4; RB 1 MHz; VB: 3 kHz
2389.850	48.0	V	74.0	-26.0	PK	139	1.0	POS; RB 1 MHz; VB: 3 MHz
<b>EUT Flat</b>								
2386.170	37.1	H	54.0	-16.9	Vavg	78	2.5	Note 4; RB 1 MHz; VB: 3 kHz
2389.960	52.7	H	74.0	-21.3	PK	78	2.5	POS; RB 1 MHz; VB: 3 MHz
2386.030	35.6	V	54.0	-18.4	Vavg	144	1.0	Note 4; RB 1 MHz; VB: 3 kHz
2388.240	48.9	V	74.0	-25.1	PK	144	1.0	POS; RB 1 MHz; VB: 3 MHz
<b>EUT Upright</b>								
2386.030	36.5	V	54.0	-17.5	Vavg	136	1.0	Note 4; RB 1 MHz; VB: 3 kHz
2388.320	52.0	V	74.0	-22.0	PK	136	1.0	POS; RB 1 MHz; VB: 3 MHz
2385.970	34.7	H	54.0	-19.3	Vavg	150	1.0	Note 4; RB 1 MHz; VB: 3 kHz
2388.320	46.5	H	74.0	-27.5	PK	150	1.0	POS; RB 1 MHz; VB: 3 MHz

Client: Fitbit, Inc.	Job Number: JD101921
Model: FB403	T-Log Number: T101935
	Project Manager: Deepa Shetty
Contact: Sachin Sawalapurkar	Project Coordinator: -
Standard: FCC 15.247, RSS-247, LP0002	Class: N/A

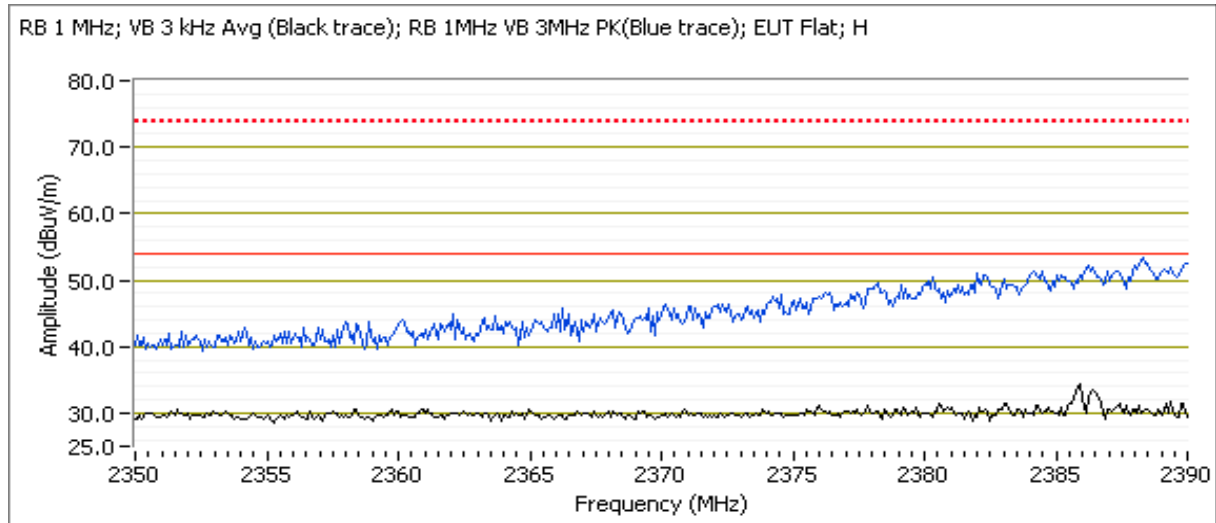
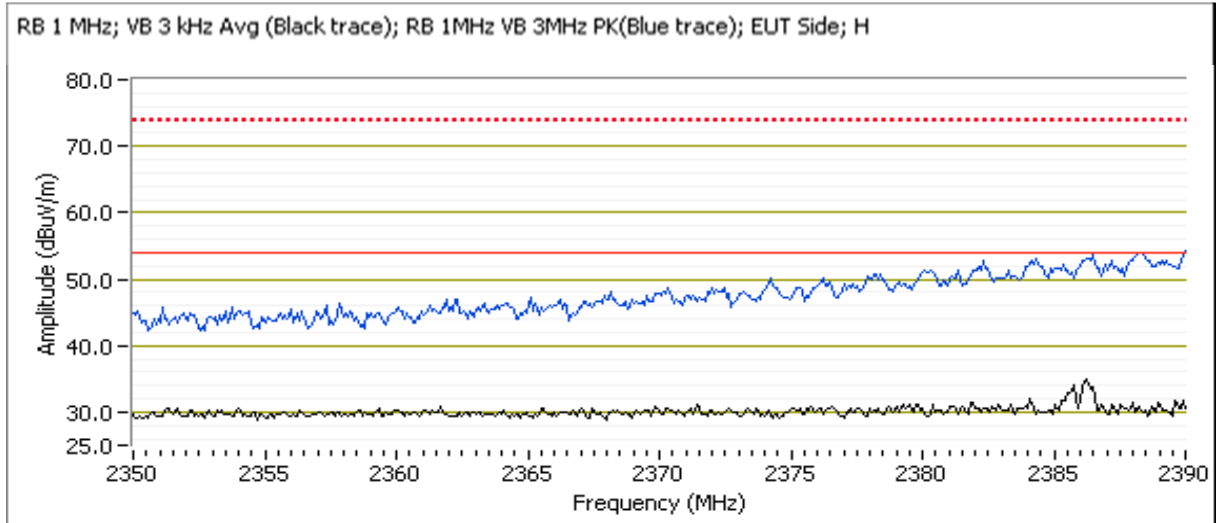

Client: Fitbit, Inc.	Job Number: JD101921
Model: FB403	T-Log Number: T101935
	Project Manager: Deepa Shetty
Contact: Sachin Sawalapurkar	Project Coordinator: -
Standard: FCC 15.247, RSS-247, LP0002	Class: N/A

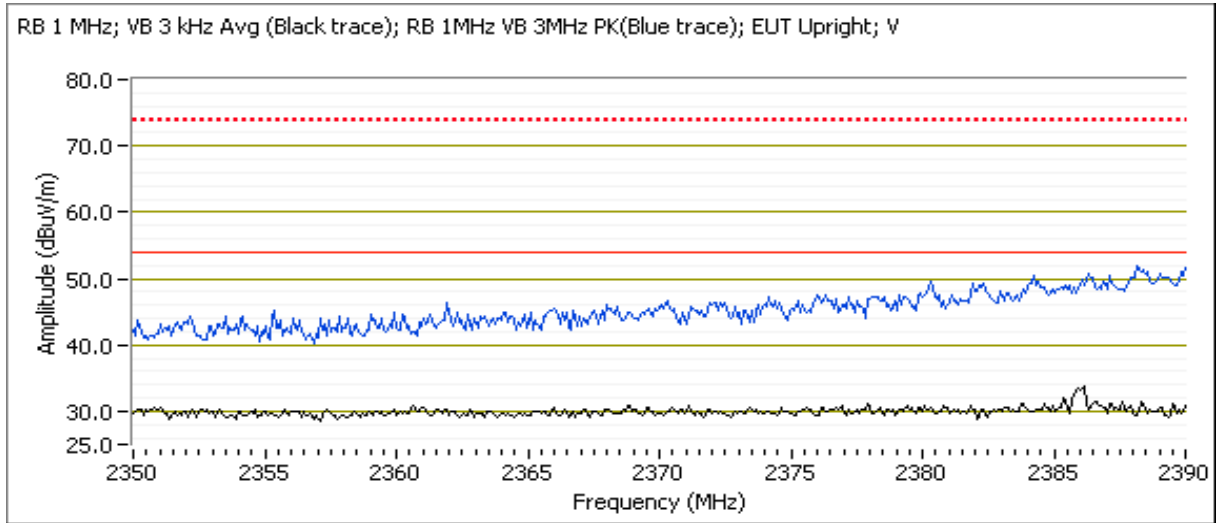



# EMC Test Data

Client: Fitbit, Inc.	Job Number: JD101921
Model: FB403	T-Log Number: T101935
	Project Manager: Deepa Shetty
Contact: Sachin Sawalapurkar	Project Coordinator: -
Standard: FCC 15.247, RSS-247, LP0002	Class: N/A

Channel: 2480                      Mode: BLE  
 Tx Chain: Main                      Data Rate: 1Mb/s

### Band Edge Signal Field Strength - Direct measurement of field strength

Frequency	Level	Pol	15.209 / 15.247		Detector	Azimuth	Height	Comments
MHz	dB $\mu$ V/m	v/h	Limit	Margin	PK/QP/Avg	degrees	meters	
<b>EUT Side</b>								
2483.600	40.3	H	54.0	-13.7	Vavg	80	2.4	Note 4; RB 1 MHz; VB: 3 kHz
2484.260	65.3	H	74.0	-8.7	PK	80	2.4	POS; RB 1 MHz; VB: 3 MHz
2483.570	37.0	V	54.0	-17.0	Vavg	195	1.0	Note 4; RB 1 MHz; VB: 3 kHz
2484.190	58.9	V	74.0	-15.1	PK	195	1.0	POS; RB 1 MHz; VB: 3 MHz

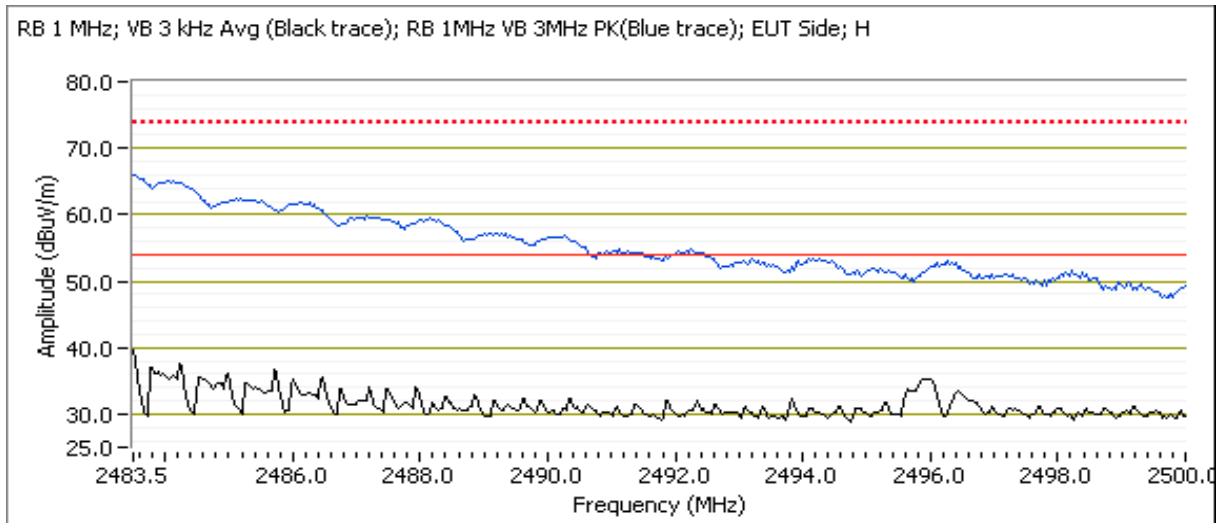

Client: Fitbit, Inc.	Job Number: JD101921
Model: FB403	T-Log Number: T101935
	Project Manager: Deepa Shetty
Contact: Sachin Sawalapurkar	Project Coordinator: -
Standard: FCC 15.247, RSS-247, LP0002	Class: N/A

## RSS-247 and FCC 15.247 (DTS) Antenna Port Measurements Power, PSD, Bandwidth and Spurious Emissions

### Test Specific Details

Objective: The objective of this test session is to perform final qualification testing of the EUT with respect to the specification listed above.

Date of Test: 7/5/2016  
 Test Engineer: Mehran Birgani  
 Test Location: Lab 3

Config. Used: Conducted  
 Config Change: -  
 Host EUT Voltage: 120V/ 60Hz

### General Test Configuration

The EUT was connected to the spectrum analyzer or power meter via a suitable attenuator. All measurements were made on a single chain.

All measurements have been corrected to allow for the external attenuators used.

### Ambient Conditions:

Temperature: 23-24 °C  
 Rel. Humidity: 33-35 %

### Summary of Results

Run #	Pwr setting	Avg Pwr	Test Performed	Limit	Pass / Fail	Result / Margin
1	13		Output Power	15.247(b)	Pass	4.0 dBm
2	13		Power spectral Density (PSD)	15.247(d)	Pass	-6.7 dBm/10kHz
3	13		Minimum 6dB Bandwidth	15.247(a)	Pass	0.71 MHz
3	13		99% Bandwidth	RSS GEN	-	1.05 MHz
4	13		Spurious emissions	15.247(b)	Pass	all below -30dBc

### Modifications Made During Testing

No modifications were made to the EUT during testing

### Deviations From The Standard

No deviations were made from the requirements of the standard.



# EMC Test Data

Client: Fitbit, Inc.	Job Number: JD101921
Model: FB403	T-Log Number: T101935
	Project Manager: Deepa Shetty
Contact: Sachin Sawalapurkar	Project Coordinator: -
Standard: FCC 15.247, RSS-247, LP0002	Class: N/A

## Procedure Comments:

Measurements performed in accordance with FCC KDB 558074

	Mode	Data Rate	Duty Cycle (x)	Constant DC?	T (ms)	Pwr Cor Factor*	Lin Volt Cor Factor**	Min VBW for FS (Hz)
<b>B2-01</b>	BLE	1 Mbps	63.0%	Yes	0.39	2.0	4.0	2538
<b>B2-02</b>	BLE	1 Mbps	63.0%	Yes	0.39	2.0	4.0	2584

## Sample Notes

Sample S/N: 0x188597a6a862

Driver: 24.08

## Run #1: Output Power

**Mode: BLE**

Power Setting <sup>2</sup>	Frequency (MHz)	Output Power		Antenna Gain (dBi)	Result	EIRP		Output Power	
		(dBm) <sup>1</sup>	mW			dBm	W	(dBm) <sup>3</sup>	mW
13	2402	3.7	2.3	-2.0	Pass	1.7	0.001		
13	2442	3.9	2.5	-2.0	Pass	1.9	0.002		
13	2480	4.0	2.5	-2.0	Pass	2.0	0.002		

Note 1:	Output power measured using gated average power meter. (option AVGPM-G in ANSI C63.10). Spurious limit becomes -30dBc. (Measurement performed on 7/25)
Note 2:	Power setting - the software power setting used during testing, included for reference only.

Client: Fitbit, Inc.	Job Number: JD101921
Model: FB403	T-Log Number: T101935
	Project Manager: Deepa Shetty
Contact: Sachin Sawalapurkar	Project Coordinator: -
Standard: FCC 15.247, RSS-247, LP0002	Class: N/A

## Run #2: Power spectral Density

Mode: BLE

Power Setting	Frequency (MHz)	PSD	Limit dBm/3kHz	Result
		(dBm/10kHz) <small>Note 1</small>		
13	2402	-6.8	8.0	Pass
13	2442	-6.7	8.0	Pass
13	2480	-6.9	8.0	Pass

Note 1: Test performed per method PKSPD, in KDB 558074. Power spectral density measured using:  $3\text{kHz} \leq \text{RBW} \leq 100\text{kHz}$ ,  $\text{VBW}=3*\text{RBW}$ , peak detector, span =  $1.5*\text{DTS BW}$ , auto sweep time, max hold.

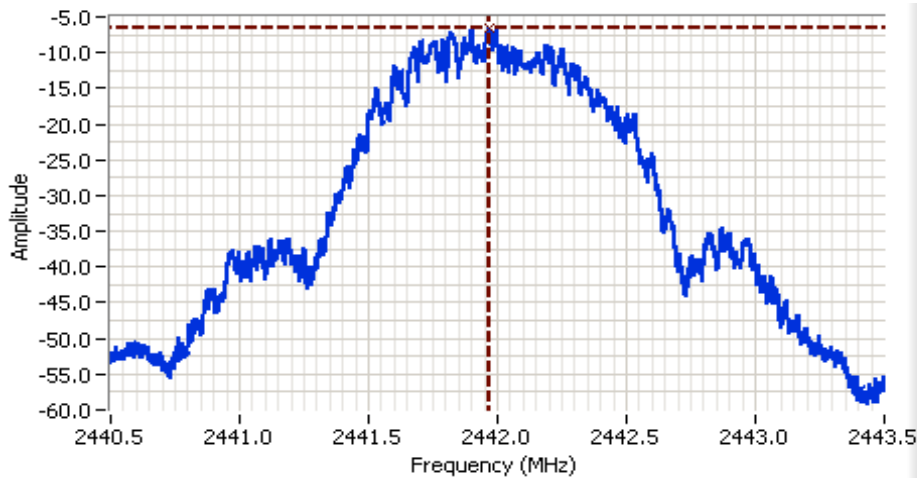

### Analyzer Settings

Rohde&Schwarz,FSQ  
 CF: 2442.000 MHz  
 SPAN: 3.000 MHz  
 RB: 10.0 kHz  
 VB: 30.0 kHz  
 Detector: POS  
 Attn: 10 DB  
 RL Offset: 12.5 DB  
 Sweep Time: 80.0ms  
 Ref Lvl: 5.5 DBM

### Comments

PSD: -6.7dBm/10kHz

Cursor 1	2441.9688	-6.7	
	0.0000	0.0	



Client: Fitbit, Inc.	Job Number: JD101921
Model: FB403	T-Log Number: T101935
	Project Manager: Deepa Shetty
Contact: Sachin Sawalapurkar	Project Coordinator: -
Standard: FCC 15.247, RSS-247, LP0002	Class: N/A

### Run #3: Signal Bandwidth

Mode: **BLE**

Power Setting	Frequency (MHz)	Bandwidth (MHz)		RBW Setting (kHz)	
		DTS	99%	DTS	99%
13	2402	0.71	1.04	100	30
13	2442	0.73	1.05	100	30
13	2480	0.75	1.05	100	30

Note 1: DTS BW: RBW=100kHz, VBW ≥ 3\*RBW, peak detector, max hold, auto sweep time, Span 2-5 times measured BW.  
 99% BW: RBW=1-5% of 99%BW, VBW ≥ 3\*RBW, peak detector, max hold, auto sweep time. Span 1.5-5 times OBW.

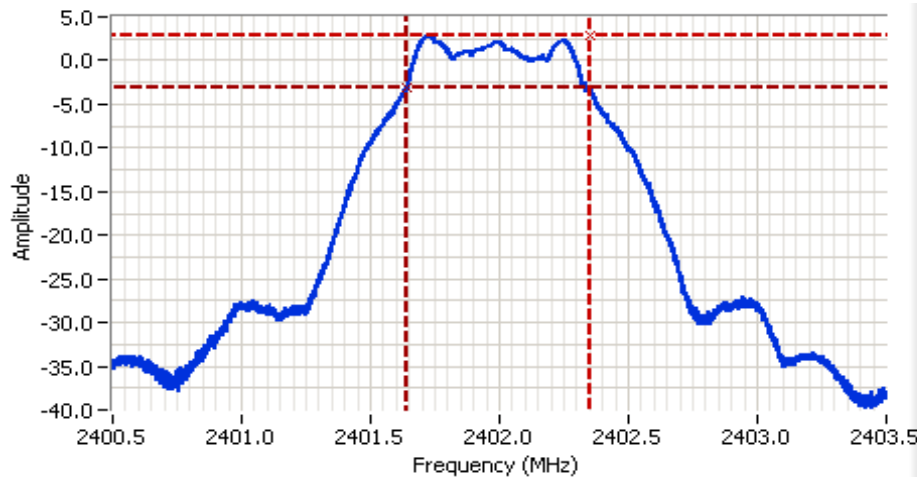

**Analyzer Settings**

Rohde&Schwarz,FSQ  
 CF: 2402.000 MHz  
 SPAN: 3.000 MHz  
 RB: 100 kHz  
 VB: 300 kHz  
 Detector: POS  
 Attn: 10 DB  
 RL Offset: 12.5 DB  
 Sweep Time: 45.0ms  
 Ref Lvl: 5.5 DBM

---

**Comments**

6dB BW: 709 kHz

Cursor 1	2402.3534	2.8		Delta Freq.	709 kHz
Cursor 2	2401.6442	-3.2		Delta Amplitude	6.0

Client: Fitbit, Inc.	Job Number: JD101921
Model: FB403	T-Log Number: T101935
Contact: Sachin Sawalapurkar	Project Manager: Deepa Shetty
Standard: FCC 15.247, RSS-247, LP0002	Project Coordinator: -
	Class: N/A

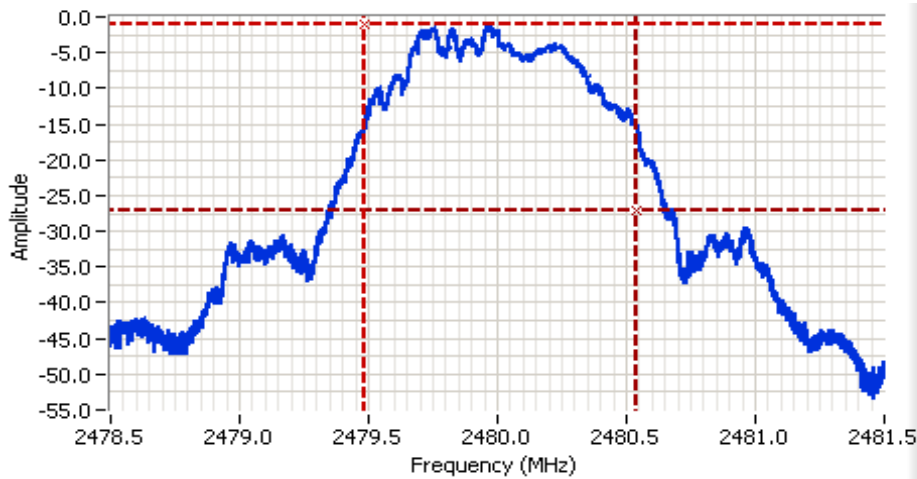
**Analyzer Settings**

Rohde&Schwarz,FSQ  
 CF: 2480.000 MHz  
 SPAN: 3.000 MHz  
 RB: 30.0 kHz  
 VB: 100 kHz  
 Detector: POS  
 Attn: 10 DB  
 RL Offset: 12.5 DB  
 Sweep Time: 45.0ms  
 Ref Lvl: 5.5 DBM

**Comments**

99% BW: 1.05 MHz

Cursor 1	2479.4833	-1.0	
Cursor 2	2480.5374	-27.0	

Delta Freq. 1.054  
 Delta Amplitude 26.0



**Run #4a: Out of Band Spurious Emissions**

Frequency (MHz)	Power Setting	Mode	Limit	Result
2402	13	BLE	-30dBc	Pass
2442	13	BLE	-30dBc	Pass
2480	13	BLE	-30dBc	Pass

Note 1: RBW=100kHz, VBW = 300kHz, peak detector, max hold, auto sweep time for all the plots.

Client: Fitbit, Inc.	Job Number: JD101921
Model: FB403	T-Log Number: T101935
	Project Manager: Deepa Shetty
Contact: Sachin Sawalapurkar	Project Coordinator: -
Standard: FCC 15.247, RSS-247, LP0002	Class: N/A

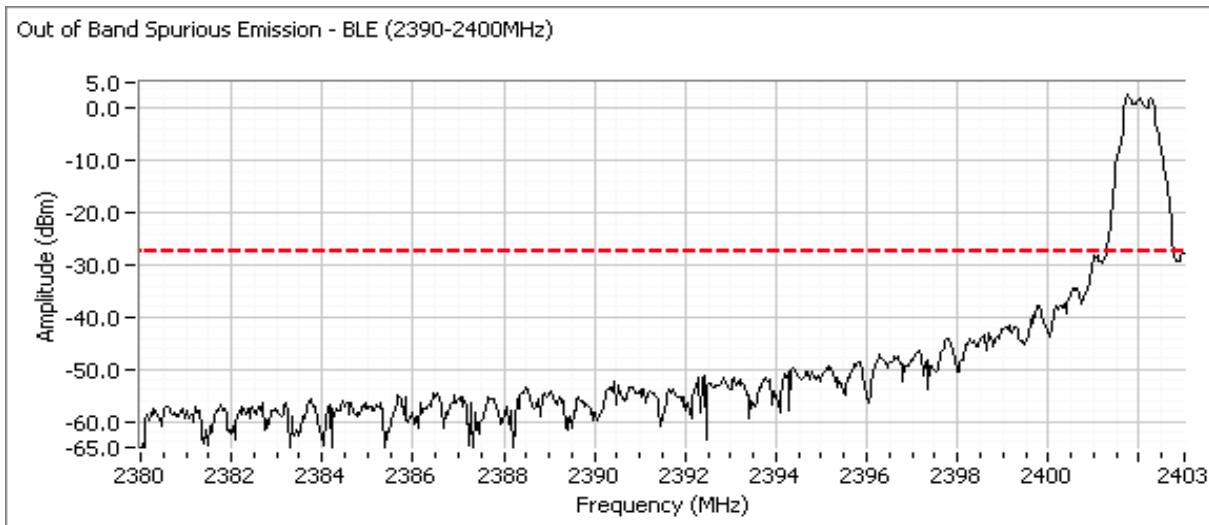
Plots for low channel



Additional plot showing compliance with -30dBc limit from 2390 MHz to 2400 MHz. Radiated measurements used to show compliance with the limits in the restricted band below 2390 MHz.

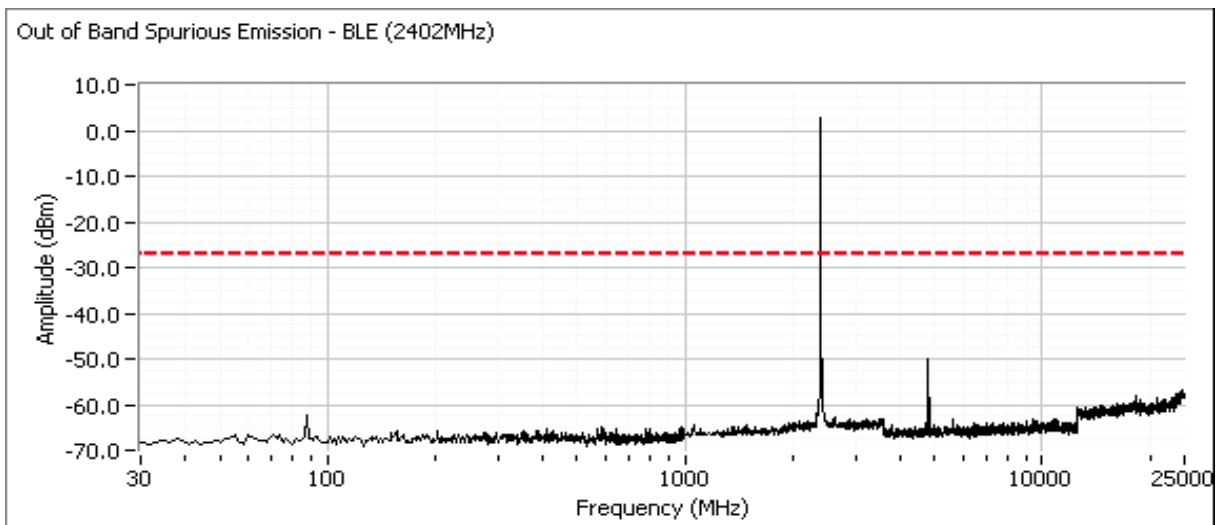

Client: Fitbit, Inc.	Job Number: JD101921
Model: FB403	T-Log Number: T101935
	Project Manager: Deepa Shetty
Contact: Sachin Sawalapurkar	Project Coordinator: -
Standard: FCC 15.247, RSS-247, LP0002	Class: N/A

Plots for center channel

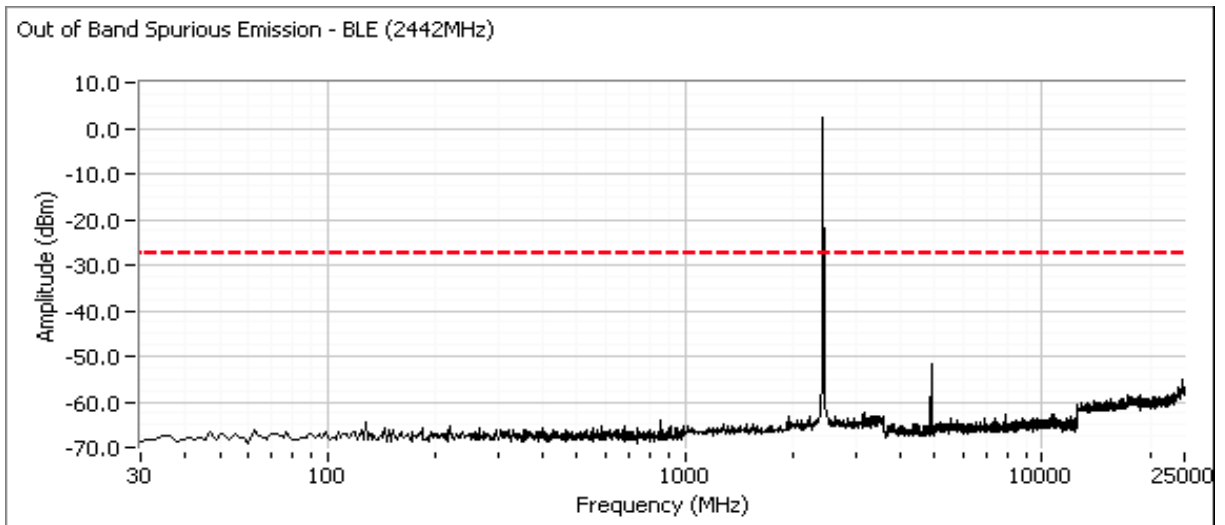

Plots for high channel

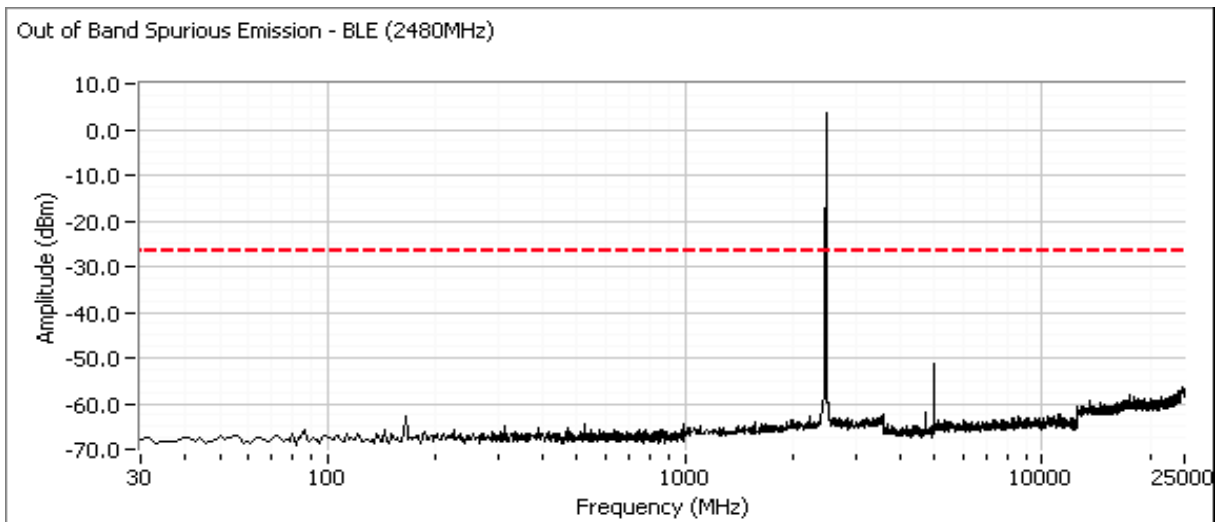



# EMC Test Data

Client: Fitbit, Inc.	Job Number: JD101921
Model: FB403	T-Log Number: T101935
	Project Manager: Deepa Shetty
Contact: Sachin Sawalapurkar	Project Coordinator: -
Standard: FCC 15.247, RSS-247, LP0002	Class: -

## Conducted Emissions

(NTS Silicon Valley, Fremont Facility, Semi-Anechoic Chamber)

### Test Specific Details

Objective: The objective of this test session is to perform final qualification testing of the EUT with respect to the specification listed above.

Date of Test: 7/1/2016 0:00	Config. Used: 1
Test Engineer: Rafael Varelas	Config Change: none
Test Location: Chamber #7	EUT Voltage: 120V / 60Hz

### General Test Configuration

For tabletop equipment, the EUT was located on a wooden table inside the semi-anechoic chamber, 40 cm from a vertical coupling plane and 80cm from the LISN.

**Ambient Conditions:** Temperature: 22.6 °C  
Rel. Humidity: 35 %

### Summary of Results

Run #	Test Performed	Limit	Result	Margin
1	CE, AC Power, 120V/60Hz	FCC 15.207	Pass	20.3 dBµV @ 0.590 MHz (-25.7 dB)

### Modifications Made During Testing

No modifications were made to the EUT during testing

### Deviations From The Standard

No deviations were made from the requirements of the standard.

### Sample Notes

Sample S/N: 0x180b9126b042 (EVT2-01)  
Driver: 24.08, build 0x00000001, compiled 5/18/16  
Antenna: internal

### Notes:

EUT configured to transmit on channel 20 at power setting 13

Client: Fitbit, Inc.	Job Number: JD101921
Model: FB403	T-Log Number: T101935
	Project Manager: Deepa Shetty
Contact: Sachin Sawalapurkar	Project Coordinator: -
Standard: FCC 15.247, RSS-247, LP0002	Class: -

**Run #1: AC Power Port Conducted Emissions, 0.15 - 30MHz, 120V/60Hz**

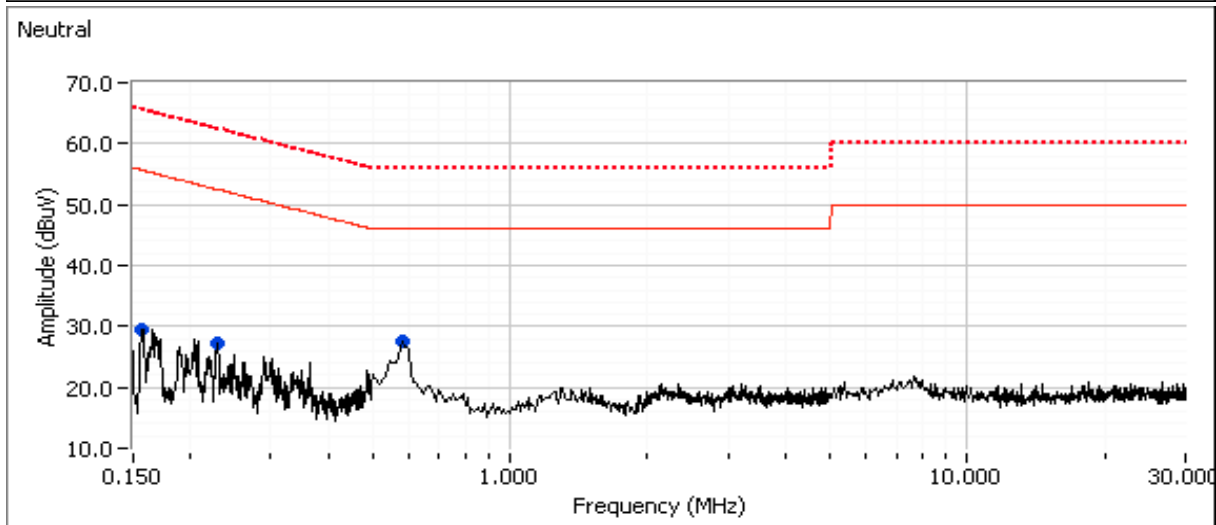
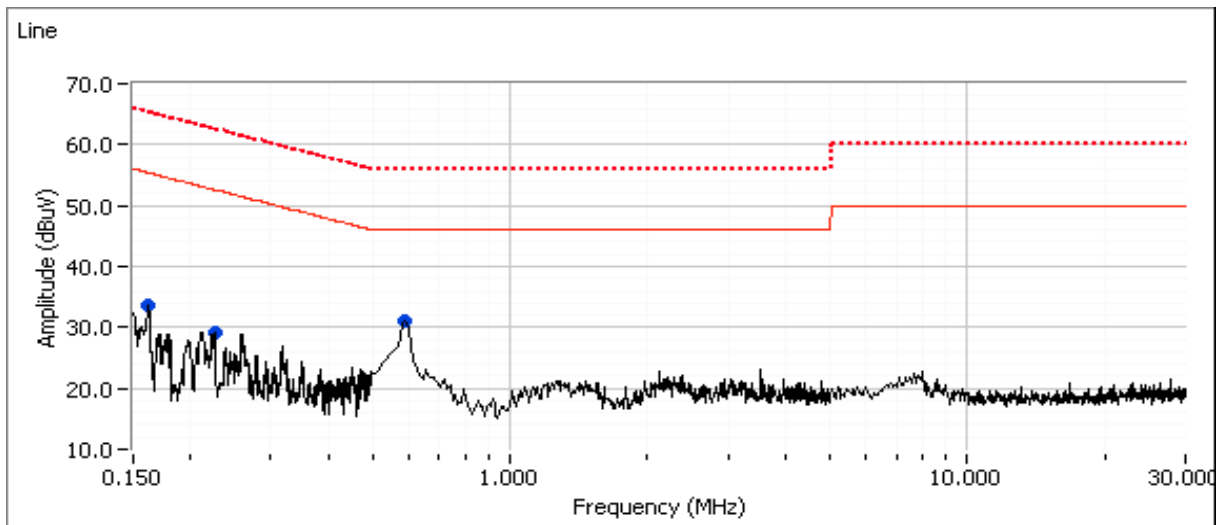



# EMC Test Data

Client: Fitbit, Inc.	Job Number: JD101921
Model: FB403	T-Log Number: T101935
	Project Manager: Deepa Shetty
Contact: Sachin Sawalapurkar	Project Coordinator: -
Standard: FCC 15.247, RSS-247, LP0002	Class: -

### Preliminary peak readings captured during pre-scan (peak readings vs. average limit)

Frequency MHz	Level dB $\mu$ V	AC Line	FCC 15.207		Detector QP/Ave	Comments
			Limit	Margin		
0.162	33.7	Line 1	55.4	-21.7	Peak	
0.225	29.3	Line 1	52.6	-23.3	Peak	
0.590	31.0	Line 1	46.0	-15.0	Peak	
0.157	29.5	Neutral	55.6	-26.1	Peak	
0.229	27.2	Neutral	52.5	-25.3	Peak	
0.587	27.5	Neutral	46.0	-18.5	Peak	

### Final quasi-peak and average readings

Frequency MHz	Level dB $\mu$ V	AC Line	FCC 15.207		Detector QP/Ave	Comments
			Limit	Margin		
<b>0.590</b>	<b>20.3</b>	Line 1	46.0	<b>-25.7</b>	AVG	AVG (0.10s)
0.587	19.0	Neutral	46.0	-27.0	AVG	AVG (0.10s)
0.590	28.0	Line 1	56.0	-28.0	QP	QP (1.00s)
0.587	24.3	Neutral	56.0	-31.7	QP	QP (1.00s)
0.162	24.9	Line 1	65.4	-40.5	QP	QP (1.00s)
0.225	21.7	Line 1	62.6	-40.9	QP	QP (1.00s)
0.225	11.3	Line 1	52.6	-41.3	AVG	AVG (0.10s)
0.157	24.2	Neutral	65.6	-41.4	QP	QP (1.00s)
0.229	10.7	Neutral	52.5	-41.8	AVG	AVG (0.10s)
0.229	20.1	Neutral	62.5	-42.4	QP	QP (1.00s)
0.162	12.2	Line 1	55.4	-43.2	AVG	AVG (0.10s)
0.157	10.7	Neutral	55.6	-44.9	AVG	AVG (0.10s)

***End of Report***

This page is intentionally blank and marks the last page of this test report.