



# MEASUREMENT REPORT

## FCC Part 15B

---

**FCC ID:** XR3-N96

**APPLICANT:** Onyx International Inc.

**Application Type:** Certification

**Product:** E-reader

**Model No.:** N96, N96 ML, N96C ML, ONYX BOOX PROMETHEUS,  
ONYX BOOX CHRONOS, ONYX BOOX MONTE  
CRISTO

**FCC Rule Part(s):** FCC Part 15 Subpart B: 2014

**Test Procedure(s):** ANSI C63.4: 2014

**Test Date:** January 19 ~ March 09, 2016

Reviewed By : Robin Wu  
( Robin Wu )

Approved By : Marlin Chen  
( Marlin Chen )



The test results relate only to the samples tested.

This equipment has been shown to be capable of compliance with the applicable technical standards as indicated in the measurement report and was tested in accordance with the measurement procedures specified in ANSI C63.4-2014. Test results reported herein relate only to the item(s) tested.

The test report shall not be reproduced except in full without the written approval of MRT Technology (Suzhou) Co., Ltd.

---

### Revision History

Report No.	Version	Description	Issue Date
1601RSU01408	Rev. 01	Initial report	03-18-2016

---

## CONTENTS

Description	Page
<b>§2.1033 General Information .....</b>	<b>4</b>
<b>1. INTRODUCTION .....</b>	<b>5</b>
1.1. Scope .....	5
1.2. MRT Test Location.....	5
<b>2. PRODUCT INFORMATION .....</b>	<b>6</b>
2.1. Product Specification Subjective to this Report.....	6
2.2. Test Mode .....	6
2.3. Test Configuration .....	7
2.4. Test System Details.....	9
2.5. Test Software .....	9
2.6. EMI Suppression Device(s)/Modifications.....	9
<b>3. DESCRIPTION OF TEST .....</b>	<b>10</b>
3.1. Evaluation Procedure .....	10
3.2. AC Line Conducted Emissions .....	10
3.3. Radiated Emissions .....	11
<b>4. TEST EQUIPMENT CALIBRATION DATE .....</b>	<b>12</b>
<b>5. MEASUREMENT UNCERTAINTY .....</b>	<b>13</b>
<b>6. TEST RESULT .....</b>	<b>14</b>
6.1. Summary .....	14
6.2. Conducted Emission Measurement .....	15
6.2.1. Test Limit .....	15
6.2.2. Test Setup.....	15
6.2.3. Test Result of Conducted Emissions.....	16
6.3. Radiated Emission Measurement .....	20
6.3.1. Test Limit .....	20
6.3.2. Test Setup.....	20
6.3.3. Test Result of Radiated Emissions.....	22

## §2.1033 General Information

<b>Applicant:</b>	Onyx International Inc.
<b>Applicant Address:</b>	Room 102, 3rd Floor, No. 38 HongLou Road, LiWan District, GuangZhou, China
<b>Manufacturer:</b>	Onyx International Inc.
<b>Manufacturer Address:</b>	Room 102, 3rd Floor, No. 38 HongLou Road, LiWan District, GuangZhou, China
<b>Test Site:</b>	MRT Technology (Suzhou) Co., Ltd
<b>Test Site Address:</b>	D8 Building, Youxin Industrial Park, No.2 Tian'edang Rd., Wuzhong Economic Development Zone, Suzhou, China
<b>MRT FCC Registration No.:</b>	809388
<b>FCC ID:</b>	XR3-N96
<b>Model No.:</b>	N96, N96 ML, N96C ML, ONYX BOOX PROMETHEUS, ONYX BOOX CHRONOS, ONYX BOOX MONTE CRISTO
<b>Test Device Serial No.:</b>	N/A <input type="checkbox"/> Production <input checked="" type="checkbox"/> Pre-Production <input type="checkbox"/> Engineering

### Test Facility / Accreditations

Measurements were performed at MRT Laboratory located in Tian'edang Rd., Suzhou, China.

- MRT facility is a FCC registered (MRT Reg. No. 809388) test facility with the site description report on file and has met all the requirements specified in Section 2.948 of the FCC Rules.
- MRT facility is an IC registered (MRT Reg. No. 11384A-1) test laboratory with the site description on file at Industry Canada.
- MRT facility is a VCCI registered (R-4179, G-814, C-4664, T-2206) test laboratory with the site description on file at VCCI Council.
- MRT Lab is accredited to ISO 17025 by the American Association for Laboratory Accreditation (A2LA) under the American Association for Laboratory Accreditation Program (A2LA Cert. No. 3628.01) in EMC, Telecommunications and Radio testing for FCC, Industry Canada, EU and TELEC Rules.



## 1. INTRODUCTION

### 1.1. Scope

Measurement and determination of electromagnetic emissions (EMC) of radio frequency devices including intentional and/or unintentional radiators for compliance with the technical rules and regulations of the Federal Communications Commission and the Industry Canada Certification and Engineering Bureau.

### 1.2. MRT Test Location

The map below shows the location of the MRT LABORATORY, its proximity to the Taihu Lake. These measurement tests were conducted at the MRT Technology (Suzhou) Co., Ltd. Facility located at D8 Building, Youxin Industrial Park, No.2 Tian'edang Rd., Wuzhong Economic Development Zone, Suzhou, China. The detailed description of the measurement facility was found to be in compliance with the requirements of § 2.948 according to ANSI C63.4-2009 on September 30, 2013.



## 2. PRODUCT INFORMATION

### 2.1. Product Specification Subjective to this Report

Product Name	E-reader
Model No.	N96, N96 ML, N96C ML, ONYX BOOX PROMETHEUS, ONYX BOOX CHRONOS, ONYX BOOX MONTE CRISTO
Wi-Fi Specification	802.11b/g/n-HT20
Bluetooth Version	v3.0 + HS, v4.0
<b>Components</b>	
Adapter	M/N: HKC0055010-2D INPUT: 100-240V ~ 50/60Hz, 0.2A OUTPUT: 5Vdc, 1.0A

### 2.2. Test Mode

Mode 1: Charging + Reading + Playing Music
Mode 2: USB Copy

### 2.3. Test Configuration

The EUT was tested per the guidance FCC Part 15 Subpart B: 2014 and ANSI C63.4: 2014 was used to reference the appropriate EUT setup for radiated spurious emissions testing and AC line conducted testing.

Connection Diagram (Mode 1)

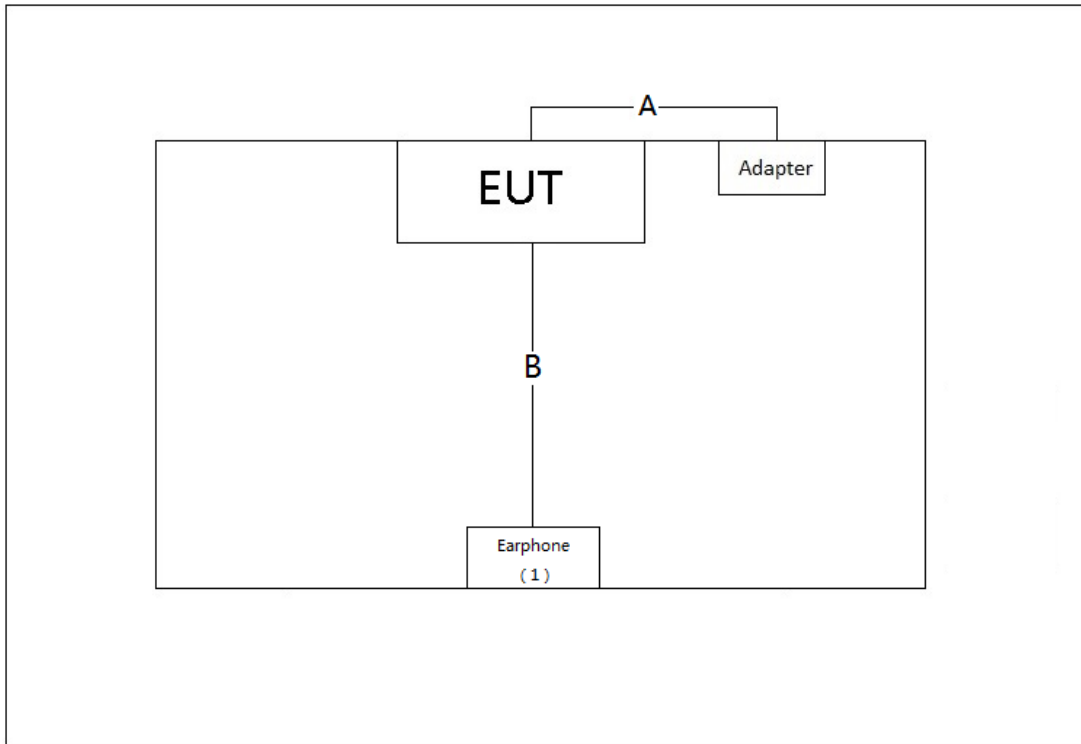

Connection Diagram (Mode 2)

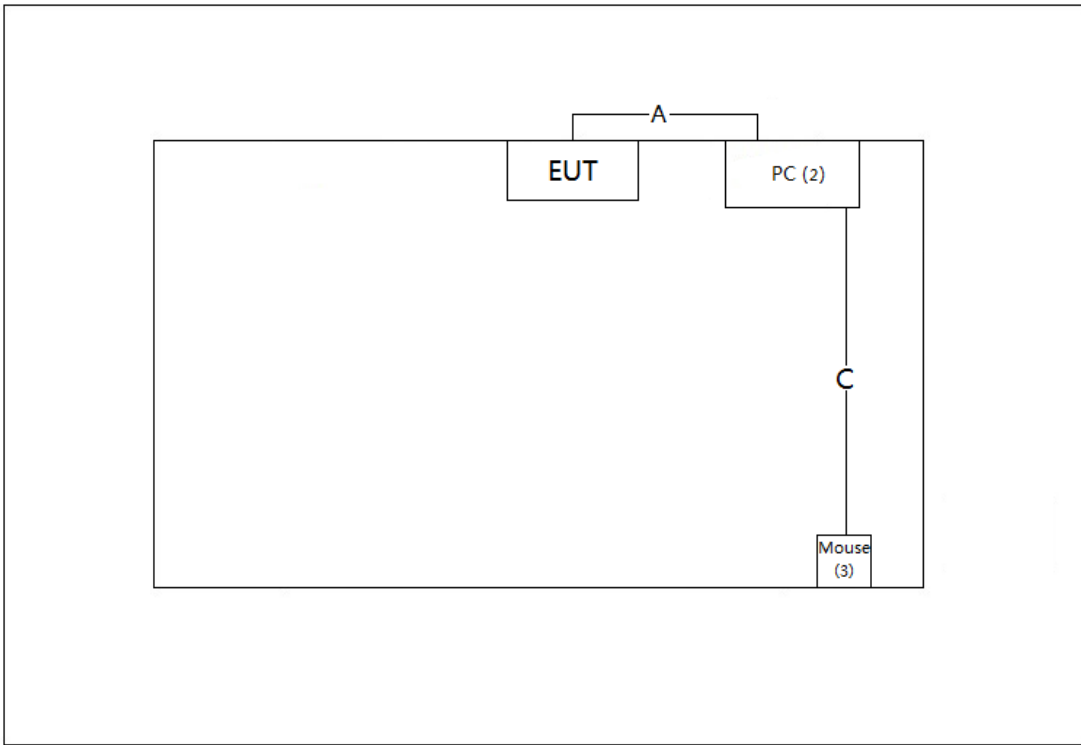

Signal Cable Type		Signal Cable Description
A	USB Cable	Shielded, 0.5m
B	Earphone Cable	Non-Shielded, 1.2m
C	USB Cable	Shielded, 1.8m



## 2.4. Test System Details

The types for all equipments, plus descriptions of all cables used in the tested system (including inserted cards) are:

Product	Manufacturer	Model No.	Serial No.	Power Cord	
1	Earphone	Apple	EarPods	N/A	N/A
2	Notebook	Lenovo	E430c	MP-4CFX213/10	Non-Shielded, 1.8m
3	USB Mouse	DELL	MS111-T	N/A	N/A

## 2.5. Test Software

1	Setup the EUT and simulators as shown on above.
2	Turn on the power of all equipment.
3	(1), Making EUT working on "Charging + Reading" Mode + Playing Music. (2), Making EUT working on "USB Copy" Mode.

## 2.6. EMI Suppression Device(s)/Modifications

No EMI suppression device(s) were added and/or no modifications were made during testing.

### 3. DESCRIPTION OF TEST

#### 3.1. Evaluation Procedure

The measurement procedures described in the American National Standard for Methods of Measurement of Radio-Noise Emission from Low-Voltage Electrical Equipment in the Range of 9kHz to 40GHz (ANSI C63.4-2014) was used in the measurement of the **E-reader**

**Deviation from measurement procedure.....None**

#### 3.2. AC Line Conducted Emissions

The line-conducted facility is located inside an 8'x4'x4' shielded enclosure. A 1m x 2m wooden table 80cm high is placed 40cm away from the vertical wall and 80cm away from the sidewall of the shielded room. Two 10kHz-30MHz, 50Ω/50uH Line-Impedance Stabilization Networks (LISNs) are bonded to the shielded room floor. Power to the LISNs is filtered by external high-current high-insertion loss power line filters. These filters attenuate ambient signal noise from entering the measurement lines. These filters are also bonded to the shielded enclosure.

The EUT is powered from one LISN and the support equipment is powered from the second LISN. If the EUT is a DC-powered device, power will be derived from the source power supply it normally will be powered from and this supply line(s) will be connected to the second LISN. All interconnecting cables more than 1 meter were shortened to a 1 meter length by non-inductive bundling (serpentine fashion) and draped over the back edge of the test table. All cables were at least 40cm above the horizontal reference ground-plane. Power cables for support equipment were routed down to the second LISN while ensuring that that cables were not draped over the second LISN.

Sufficient time for the EUT, support equipment, and test equipment was allowed in order for them to warm up to their normal operating condition. The RF output of the LISN was connected to the receiver and exploratory measurements were made to determine the frequencies producing the maximum emission from the EUT. The receiver was scanned from 150 kHz to 30 MHz. The detector function was set to peak mode for exploratory measurements while the bandwidth of the analyzer was set to 9 kHz. The EUT, support equipment, and interconnecting cables were arranged and manipulated to maximize each emission. Each emission was also maximized by varying: power lines, the mode of operation or resolution, clock or data exchange speed, scrolling H pattern to the EUT and/or support equipment whichever determined the worst-case emission. Once the worst case emissions have been identified, the one EUT cable configuration/arrangement and mode of operation that produced these emissions are used for final measurements on the same test site. Line conducted emissions test results are shown in Section 6.2.

### 3.3. Radiated Emissions

The radiated test facilities consisted of an indoor 3 meter semi-anechoic chamber used for final measurements and exploratory measurements, when necessary. The measurement area is contained within the semi-anechoic chamber which is shielded from any ambient interference. For measurements above 1GHz absorbers are arranged on the floor between the turn table and the antenna mast in such a way so as to maximize the reduction of reflections. For measurements below 1GHz, the absorbers are removed. An MF Model 210SS turntable is used for radiated measurement. It is a continuously rotatable, remote controlled, metallic turntable and 2 meters (6.56 ft.) in diameter. The turn table is flush with the raised floor of the chamber in order to maintain its function as a ground plane. An 80cm high PVC support structure is placed on top of the turntable.

For all measurements, the spectrum was scanned through all EUT azimuths and from 1 to 4 meter receive antenna height using a broadband antenna from 30 MHz up to the upper frequency shown in 15.33(b)(1) depending on the highest frequency generated or used in the device or on which the device operates or tunes. For frequencies above 1GHz, linearly polarized double ridge horn antennas were used. For frequencies below 30 MHz, a calibrated loop antenna was used. When exploratory measurements were necessary, they were performed at 1 meter test distance inside the semi-anechoic chamber using broadband antennas, broadband amplifiers, and spectrum analyzers to determine the frequencies and modes producing the maximum emissions. Sufficient time for the EUT, support equipment, and test equipment was allowed in order for them to warm up to their normal operating condition. The test set-up was placed on top of the 0.8 meter high, 1 x 1.5 meter table. The EUT, support equipment, and interconnecting cables were arranged and manipulated to maximize each emission. Appropriate precaution was taken to ensure that all emissions from the EUT were maximized and investigated. The system configuration, mode of operation, if applicable, turntable azimuth, and receive antenna height was noted for each frequency found.

Final measurements were made in the semi-anechoic chamber using calibrated, linearly polarized broadband and horn antennas. The test setup was configured to the setup that produced the worst case emissions. The spectrum analyzer was set to investigate all frequencies required for testing to compare the highest radiated disturbances with respect to the specified limits. The turntable containing the EUT was rotated through 360 degrees and the height of the receive antenna was varied 1 to 4 meters and stopped at the azimuth and height producing the maximum emission. Each emission was maximized by changing the orientation of the EUT through three orthogonal planes and changing the polarity of the receive antenna, whichever produced the worst-case emissions. According to 3dB beam-width of horn antenna, the horn antenna should be always directed to the EUT when rising height.

#### 4. TEST EQUIPMENT CALIBRATION DATE

##### Conducted Emissions – SR2

Instrument	Manufacturer	Type No.	Asset No.	Cali. Interval	Cali. Due Date
EMI Test Receiver	R&S	ESR7	MRTSUE06001	1 year	2016/11/03
Two-Line V-Network	R&S	ENV216	MRTSUE06002	1 year	2016/11/03
Two-Line V-Network	R&S	ENV216	MRTSUE06003	1 year	2016/11/03
Temperature/Humidity Meter	Yuhuaze	HTC-2	MRTSUE06182	1 year	2016/12/20

##### Radiated Emission – AC1

Instrument	Manufacturer	Type No.	Asset No.	Cali. Interval	Cali. Due Date
Spectrum Analyzer	Agilent	N9010A	MRTSUE06124	1 year	2016/06/23
EMI Test Receiver	R&S	ESR7	MRTSUE06001	1 year	2016/11/03
Microwave System Amplifier	Agilent	83017A	MRTSUE06076	1 year	2016/03/29
TRILOG Antenna	Schwarzbeck	VULB9162	MRTSUE06022	1 year	2016/11/07
Broad-Band Horn Antenna	Schwarzbeck	BBHA9120D	MRTSUE06023	1 year	2016/11/07
Temperature/Humidity Meter	Yuhuaze	HTC-2	MRTSUE06183	1 year	2016/12/20

Software	Version	Function
e3	V8.3.5	EMI Test Software

## 5. MEASUREMENT UNCERTAINTY

Where relevant, the following test uncertainty levels have been estimated for tests performed on the EUT as specified in CISPR 16-4-2. This uncertainty represents an expanded uncertainty expressed at approximately the 95% confidence level using a coverage factor of  $k = 2$ .

<b>AC Conducted Emission Measurement – SR2</b>
Measuring Uncertainty for a Level of Confidence of 95% ( $U=2Uc(y)$ ): 150kHz~30MHz: 3.5dB
<b>Radiated Emission Measurement – AC1</b>
Measuring Uncertainty for a Level of Confidence of 95% ( $U=2Uc(y)$ ): Horizontal: 30MHz~1GHz: 4.07dB 1GHz~18GHz: 4.16 dB Vertical: 30MHz~1GHz: 4.18 dB 1GHz~18GHz: 4.76 dB

## 6. TEST RESULT

### 6.1. Summary

Company Name: Onyx International Inc.

Test Mode: Mode 1: Charging + Reading + Playing Music

Mode 2: USB Copy

FCC Part Section(s)	Test Description	Test Result
15.107	Conducted Emissions	Pass
15.109	Radiated Emissions	Pass

## 6.2. Conducted Emission Measurement

### 6.2.1. Test Limit

FCC Part 15.107 Limits		
Frequency (MHz)	QP (dB $\mu$ V)	AV (dB $\mu$ V)
0.15 - 0.50	66 - 56	56 - 46
0.50 - 5.0	56	46
5.0 - 30	60	50

Note 1: The lower limit shall apply at the transition frequencies.

Note 2: The limit decreases linearly with the logarithm of the frequency in the range 0.15MHz to 0.5MHz.

### 6.2.2. Test Setup

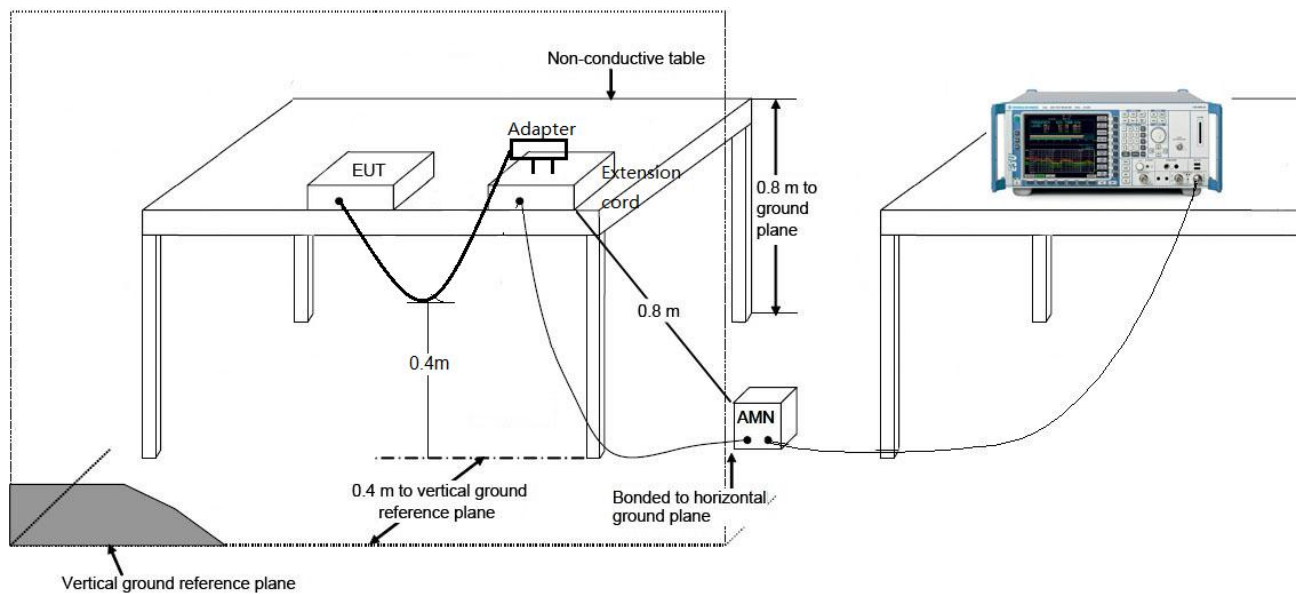

### 6.2.3. Test Result of Conducted Emissions

Site: SR2	Time: 2016/03/01 - 16:25
Limit: FCC_Part15.107_CE_Class B	Engineer: Line Chen
Probe: ENV216_101683_Filter On	Polarity: Line
EUT: E-reader	Power: AC 120V/60Hz
Test Mode 1	

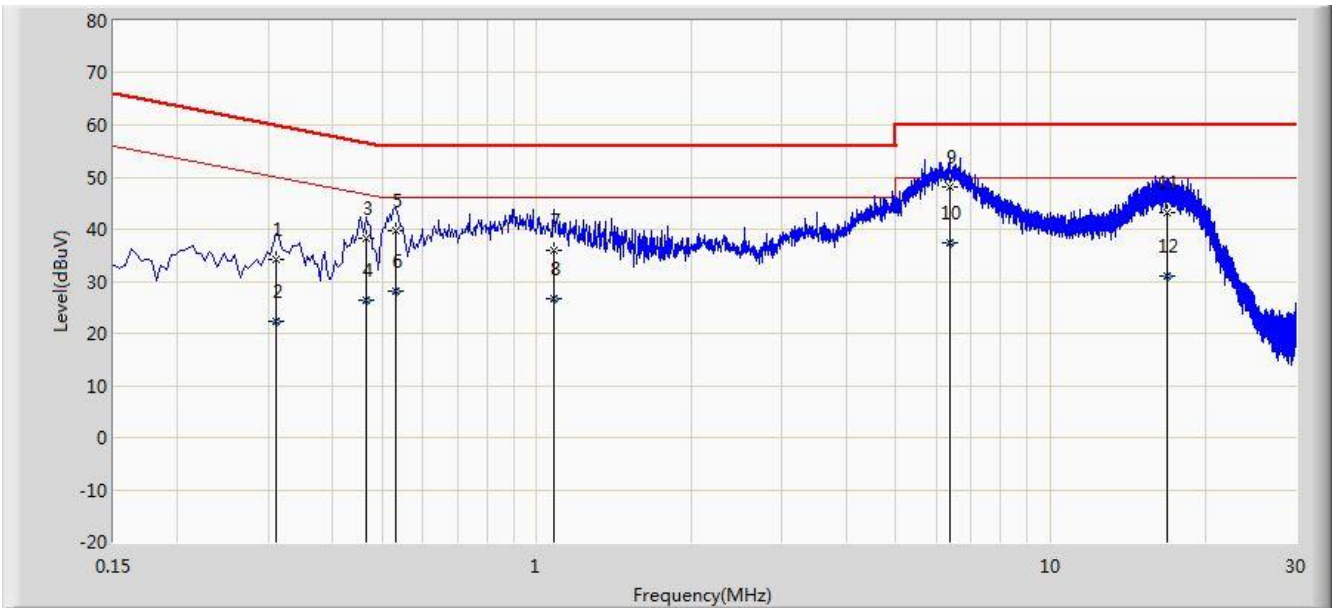

No	Flag	Mark	Frequency (MHz)	Measure Level (dBuV)	Reading Level (dBuV)	Over Limit (dB)	Limit (dBuV)	Factor (dB)	Type
1			0.310	34.169	24.157	-25.801	59.970	10.012	QP
2			0.310	22.382	12.370	-27.589	49.970	10.012	AV
3			0.466	38.194	28.055	-18.391	56.585	10.139	QP
4			0.466	26.486	16.348	-20.098	46.585	10.139	AV
5			0.530	39.779	29.628	-16.221	56.000	10.151	QP
6			0.530	28.135	17.984	-17.865	46.000	10.151	AV
7			1.078	35.811	25.906	-20.189	56.000	9.905	QP
8			1.078	26.792	16.887	-19.208	46.000	9.905	AV
9		*	6.354	47.985	37.858	-12.015	60.000	10.127	QP
10			6.354	37.451	27.324	-12.549	50.000	10.127	AV
11			16.810	43.194	33.126	-16.806	60.000	10.068	QP
12			16.810	30.951	20.883	-19.049	50.000	10.068	AV

Note: Measure Level (dB $\mu$ V) = Reading Level (dB $\mu$ V) + Factor (dB)

Factor (dB) = Cable Loss (dB) + LISN Factor (dB).



Site: SR2	Time: 2016/03/01 - 16:30
Limit: FCC_Part15.107_CE _ Class B	Engineer: Line Chen
Probe: ENV216_101683_Filter On	Polarity: Neutral
EUT: E-reader	Power: AC 120V/60Hz
Test Mode 1	

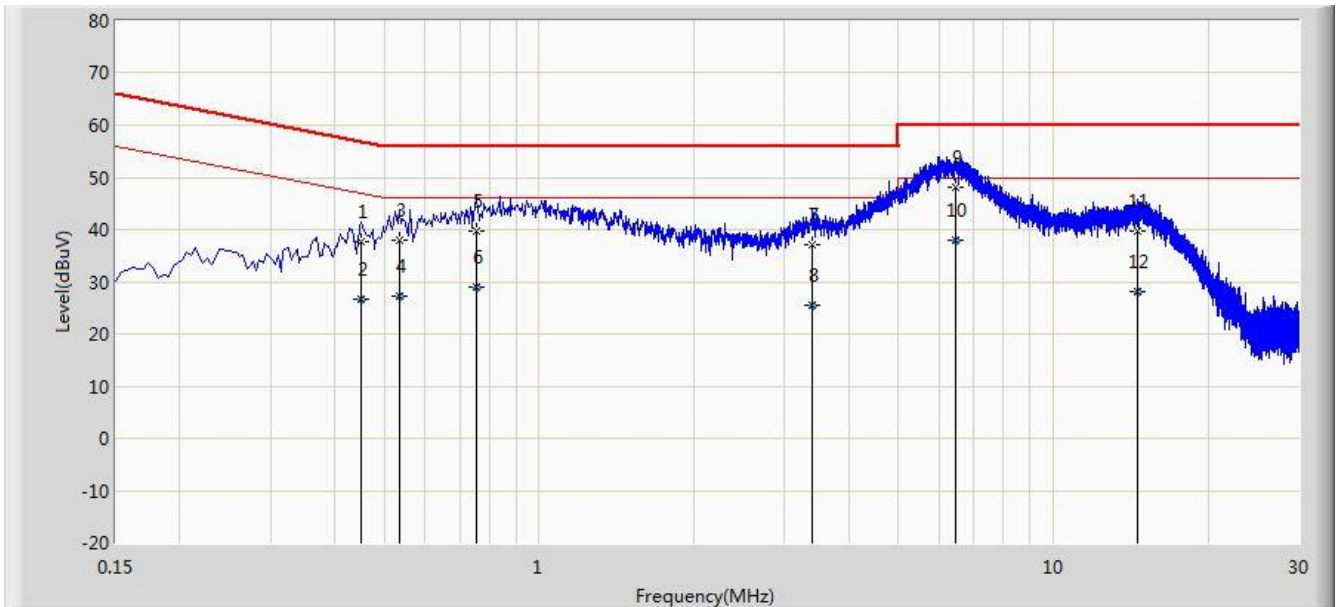

No	Flag	Mark	Frequency (MHz)	Measure Level (dBuV)	Reading Level (dBuV)	Over Limit (dB)	Limit (dBuV)	Factor (dB)	Type
1			0.450	37.587	27.437	-19.289	56.875	10.150	QP
2			0.450	26.528	16.378	-20.348	46.875	10.150	AV
3			0.534	38.103	27.935	-17.897	56.000	10.168	QP
4			0.534	27.357	17.189	-18.643	46.000	10.168	AV
5			0.754	39.805	29.760	-16.195	56.000	10.045	QP
6			0.754	29.072	19.027	-16.928	46.000	10.045	AV
7			3.402	37.146	27.239	-18.854	56.000	9.906	QP
8			3.402	25.581	15.675	-20.419	46.000	9.906	AV
9		*	6.466	48.040	37.909	-11.960	60.000	10.131	QP
10			6.466	37.967	27.835	-12.033	50.000	10.131	AV
11			14.554	39.647	29.554	-20.353	60.000	10.093	QP
12			14.554	28.170	18.077	-21.830	50.000	10.093	AV

Note: Measure Level (dBμV) = Reading Level (dBμV) + Factor (dB)

Factor (dB) = Cable Loss (dB) + LISN Factor (dB).

Site: SR2	Time: 2016/03/01 - 17:01
Limit: FCC_Part15.107_CE_Class B	Engineer: Line Chen
Probe: ENV216_101683_Filter On	Polarity: Line
EUT: E-reader	Power: AC 120V/60Hz
Test Mode 2	

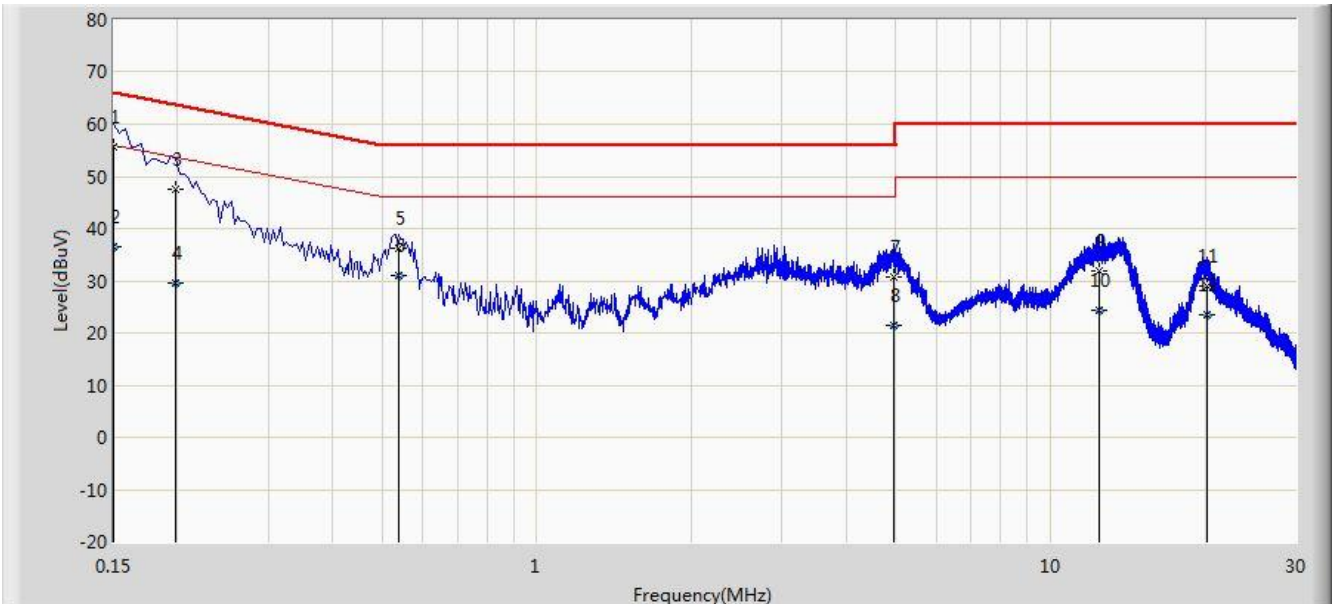

No	Flag	Mark	Frequency (MHz)	Measure Level (dBuV)	Reading Level (dBuV)	Over Limit (dB)	Limit (dBuV)	Factor (dB)	Type
1		*	0.150	55.578	44.410	-10.422	66.000	11.168	QP
2			0.150	36.528	25.359	-19.472	56.000	11.168	AV
3			0.198	47.644	37.639	-16.050	63.694	10.005	QP
4			0.198	29.561	19.556	-24.133	53.694	10.005	AV
5			0.538	36.244	26.097	-19.756	56.000	10.147	QP
6			0.538	31.117	20.970	-14.883	46.000	10.147	AV
7			4.958	30.625	20.601	-25.375	56.000	10.024	QP
8			4.958	21.363	11.339	-24.637	46.000	10.024	AV
9			12.454	31.814	21.745	-28.186	60.000	10.069	QP
10			12.454	24.467	14.398	-25.533	50.000	10.069	AV
11			20.114	28.927	18.788	-31.073	60.000	10.139	QP
12			20.114	23.338	13.199	-26.662	50.000	10.139	AV

Note: Measure Level (dBμV) = Reading Level (dBμV) + Factor (dB)

Factor (dB) = Cable Loss (dB) + LISN Factor (dB).

Site: SR2	Time: 2016/03/01 - 17:12
Limit: FCC_Part15.107_CE _ Class B	Engineer: Line Chen
Probe: ENV216_101683_Filter On	Polarity: Neutral
EUT: E-reader	Power: AC 120V/60Hz
Test Mode 2	

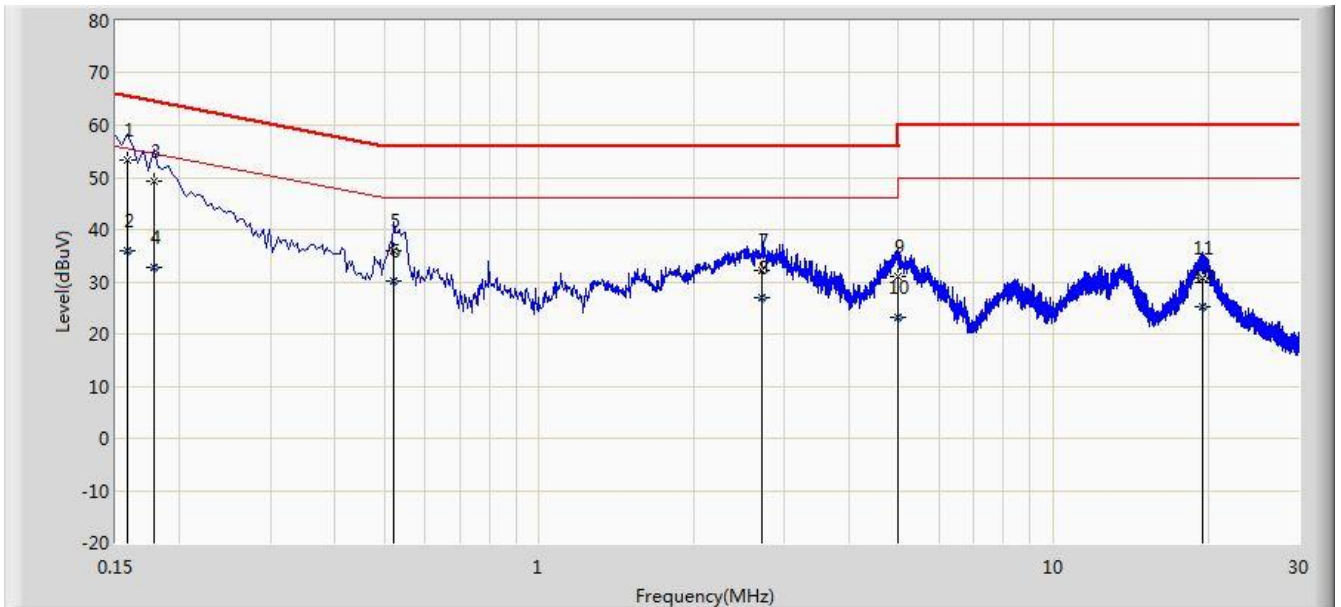

No	Flag	Mark	Frequency (MHz)	Measure Level (dBuV)	Reading Level (dBuV)	Over Limit (dB)	Limit (dBuV)	Factor (dB)	Type
1		*	0.158	53.402	43.112	-12.167	65.568	10.290	QP
2			0.158	35.811	25.522	-19.757	55.568	10.290	AV
3			0.178	49.369	39.320	-15.209	64.578	10.049	QP
4			0.178	32.733	22.684	-21.845	54.578	10.049	AV
5			0.522	36.067	25.893	-19.933	56.000	10.174	QP
6			0.522	30.254	20.080	-15.746	46.000	10.174	AV
7			2.706	32.156	22.301	-23.844	56.000	9.855	QP
8			2.706	26.942	17.087	-19.058	46.000	9.855	AV
9			4.978	31.033	20.997	-24.967	56.000	10.036	QP
10			4.978	23.047	13.011	-22.953	46.000	10.036	AV
11			19.498	30.688	20.522	-29.312	60.000	10.167	QP
12			19.498	25.341	15.174	-24.659	50.000	10.167	AV

Note: Measure Level (dBμV) = Reading Level (dBμV) + Factor (dB)

Factor (dB) = Cable Loss (dB) + LISN Factor (dB).

### 6.3. Radiated Emission Measurement

#### 6.3.1. Test Limit

FCC Part 15.109 Limits		
Frequency (MHz)	Distance (m)	Level (dB $\mu$ V/m)
30 - 88	3	40
88 - 216	3	43.5
216 - 960	3	46
Above 960	3	54

Note 1: The lower limit shall apply at the transition frequency.

Note 2: Distance refers to the distance in meters between the measuring instrument antenna and the closed point of any part of the device or system.

Note 3: E field strength (dB $\mu$ V/m) = 20 log E field strength (uV/m)

#### 6.3.2. Test Setup

30MHz ~ 1GHz Test Setup:

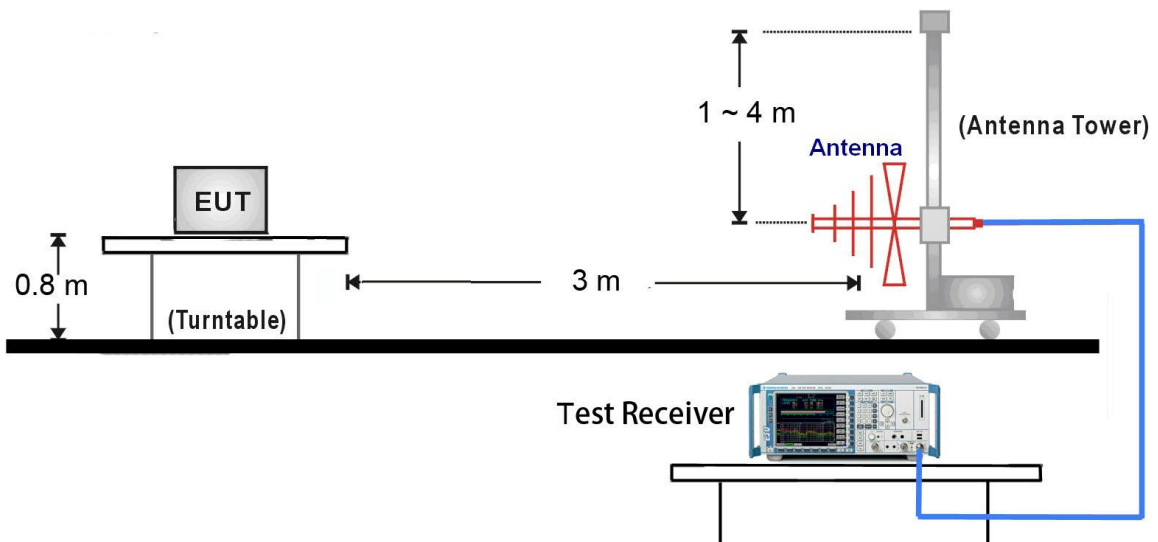

1GHz ~18GHz Test Setup:

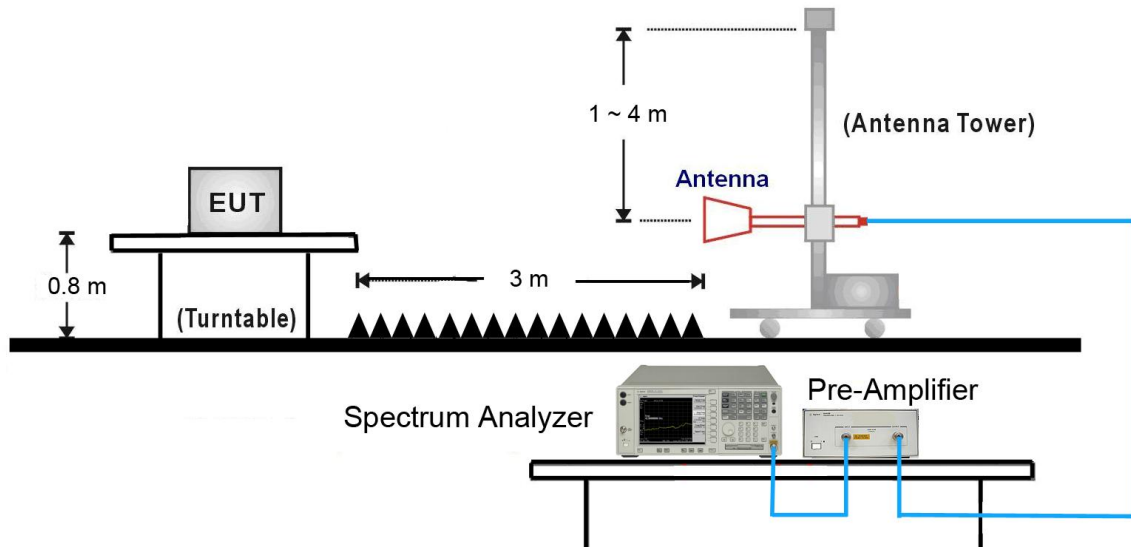

### 6.3.3. Test Result of Radiated Emissions

Site: AC1	Time: 2016/03/07 - 17:49
Limit: FCC_Part15.109_RE(3m)_Class B	Engineer: Line Chen
Probe: VULB9162_0.03-8GHz	Polarity: Horizontal
EUT: E-reader	Power: AC 120V/60Hz
Test Mode 1	

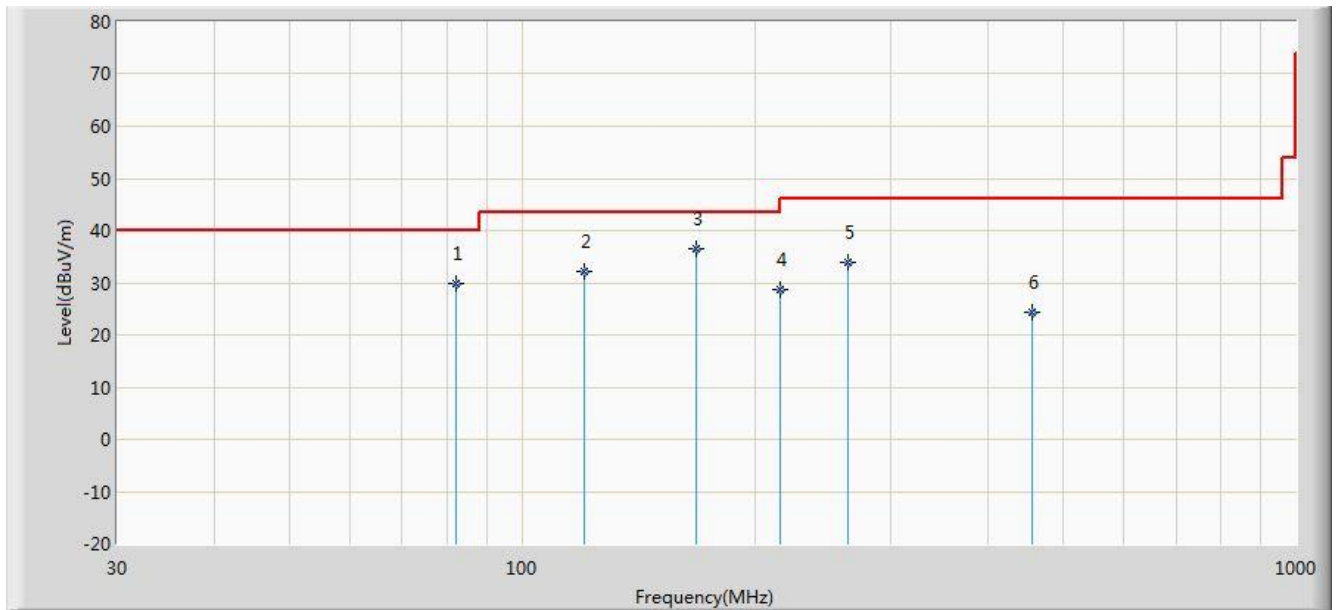

No	Flag	Mark	Frequency (MHz)	Measure Level (dBuV/m)	Reading Level (dBuV)	Over Limit (dB)	Limit (dBuV/m)	Factor (dB)	Ant Pos (cm)	Table Pos (deg)	Type
1			82.380	29.994	19.926	-10.006	40.000	10.068	100	86	QP
2			120.210	32.136	19.006	-11.364	43.500	13.130	100	125	QP
3		*	167.990	36.388	21.940	-7.112	43.500	14.448	100	98	QP
4			215.755	28.651	17.002	-14.849	43.500	11.649	100	236	QP
5			263.770	33.798	20.518	-12.202	46.000	13.280	100	205	QP
6			455.830	24.436	6.554	-21.564	46.000	17.882	100	77	QP

Note: Measure Level (dBuV/m) = Reading Level (dBuV) + Factor (dB)

Factor (dB) = Cable Loss (dB) + Antenna Factor (dB/m).

Site: AC1	Time: 2016/03/07 - 17:49
Limit: FCC_Part15.109_RE(3m)_Class B	Engineer: Line Chen
Probe: VULB9162_0.03-8GHz	Polarity: Vertical
EUT: E-reader	Power: AC 120V/60Hz
Test Mode 1	

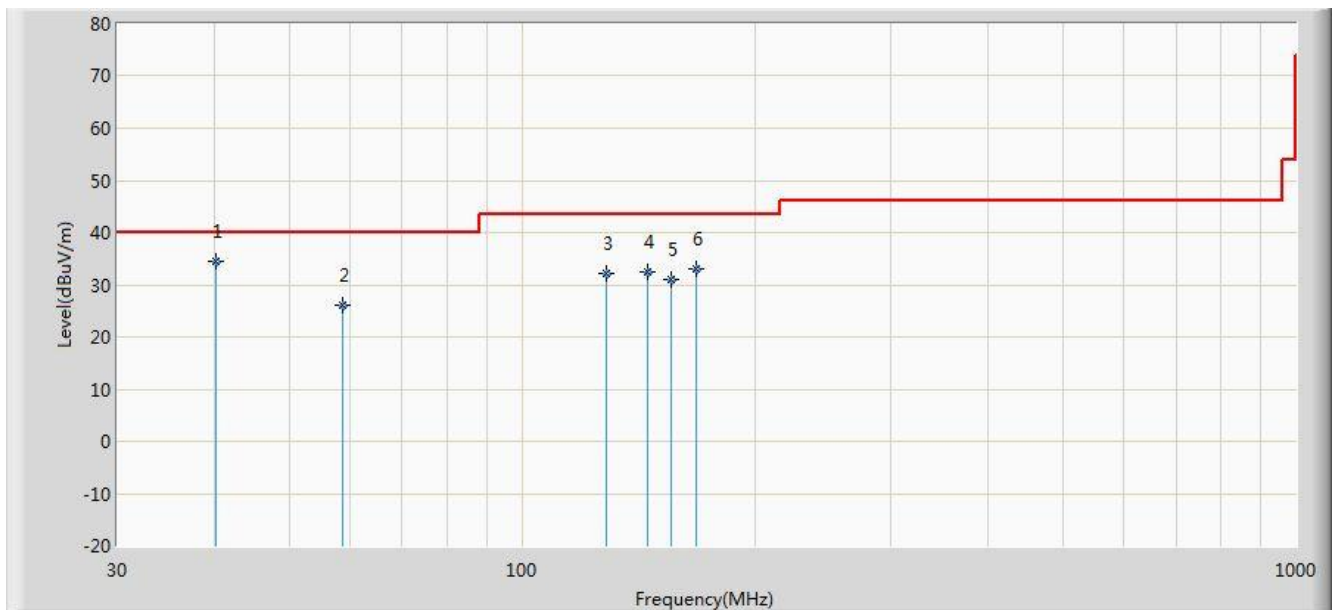

No	Flag	Mark	Frequency (MHz)	Measure Level (dBuV/m)	Reading Level (dBuV)	Over Limit (dB)	Limit (dBuV/m)	Factor (dB)	Ant Pos (cm)	Table Pos (deg)	Type
1		*	40.185	34.360	19.857	-5.640	40.000	14.503	100	89	QP
2			58.615	26.006	12.548	-13.994	40.000	13.458	100	121	QP
3			128.455	32.163	18.529	-11.337	43.500	13.634	100	101	QP
4			145.430	32.496	17.627	-11.004	43.500	14.869	100	230	QP
5			156.215	31.113	15.930	-12.387	43.500	15.183	100	208	QP
6			168.225	32.946	18.517	-10.554	43.500	14.429	100	72	QP

Note: Measure Level (dBuV/m) = Reading Level (dBuV) + Factor (dB)

Factor (dB) = Cable Loss (dB) + Antenna Factor (dB/m).

Site: AC1	Time: 2016/03/07 - 17:49
Limit: FCC_Part15.109_RE(3m)_Class B	Engineer: Line Chen
Probe: VULB9162_0.03-8GHz	Polarity: Horizontal
EUT: E-reader	Power: AC 120V/60Hz
Test Mode 2	

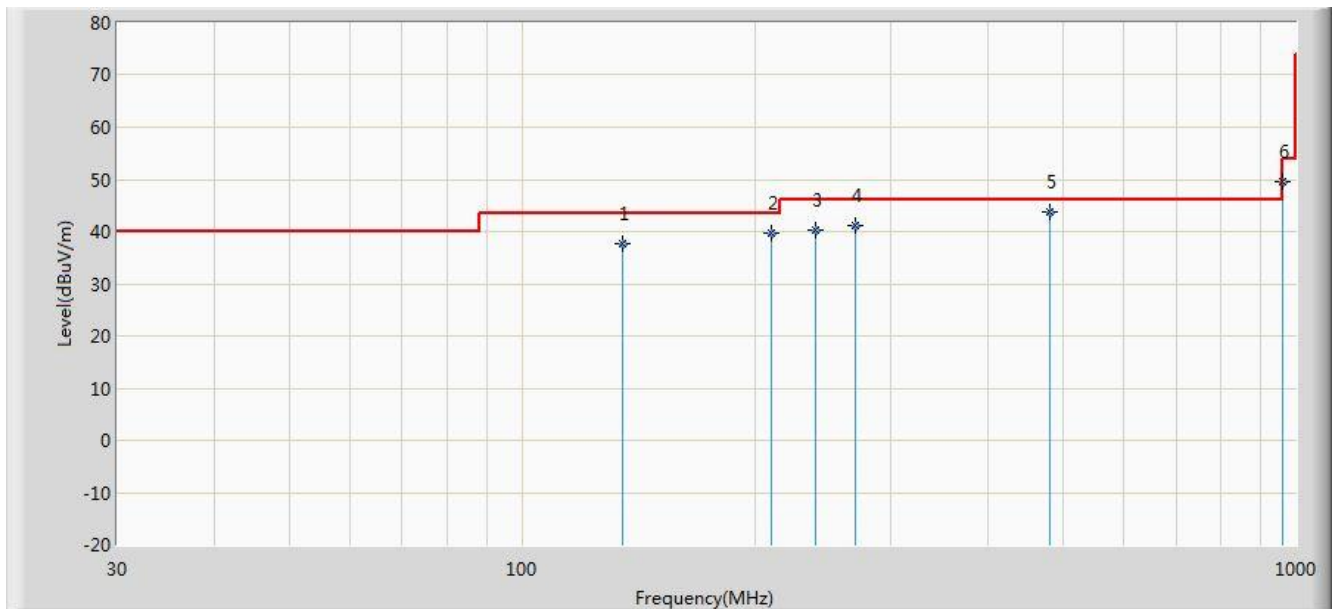

No	Flag	Mark	Frequency (MHz)	Measure Level (dBuV/m)	Reading Level (dBuV)	Over Limit (dB)	Limit (dBuV/m)	Factor (dB)	Ant Pos (cm)	Table Pos (deg)	Type
1			134.760	37.611	23.518	-5.889	43.500	14.093	100	126	QP
2			209.935	39.818	28.516	-3.682	43.500	11.302	100	163	QP
3			240.005	40.279	27.517	-5.721	46.000	12.762	100	92	QP
4			270.075	41.023	27.526	-4.977	46.000	13.497	100	256	QP
5		*	480.080	43.784	25.591	-2.216	46.000	18.193	100	289	QP
6			960.230	49.574	24.628	-4.426	54.000	24.946	100	61	QP

Note: Measure Level (dB $\mu$ V/m) = Reading Level (dB $\mu$ V) + Factor (dB)

Factor (dB) = Cable Loss (dB) + Antenna Factor (dB/m).



Site: AC1	Time: 2016/03/07 - 17:49
Limit: FCC_Part15.109_RE(3m)_Class B	Engineer: Line Chen
Probe: VULB9162_0.03-8GHz	Polarity: Vertical
EUT: E-reader	Power: AC 120V/60Hz
Test Mode 2	

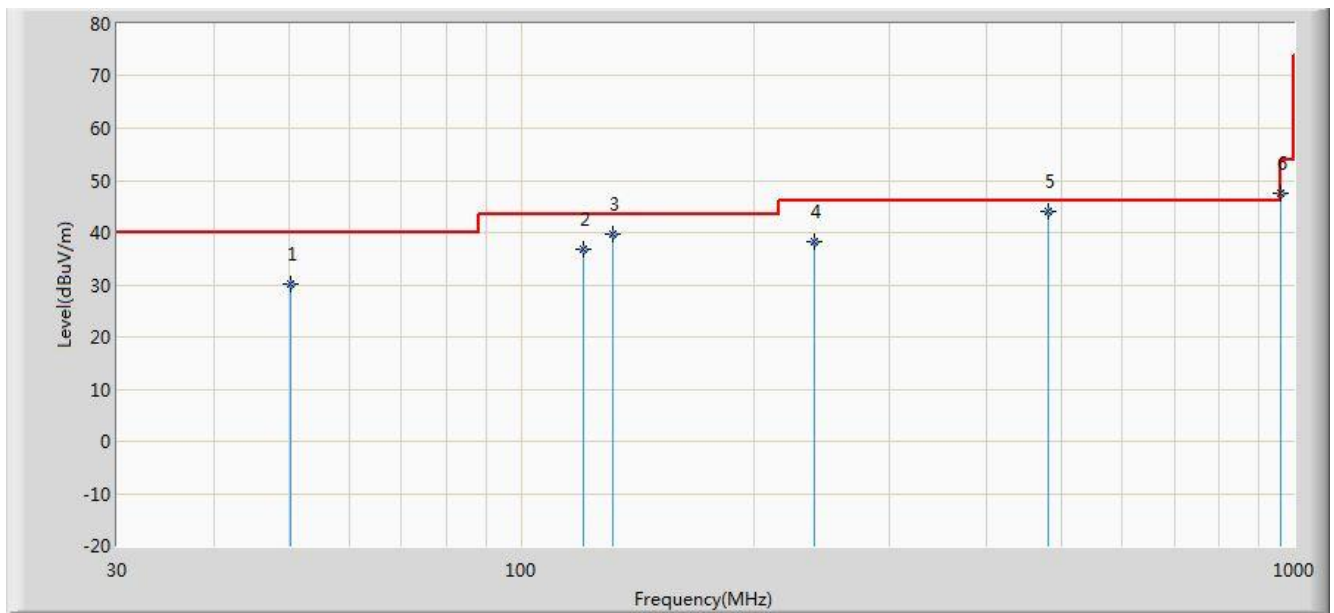

No	Flag	Mark	Frequency (MHz)	Measure Level (dBuV/m)	Reading Level (dBuV)	Over Limit (dB)	Limit (dBuV/m)	Factor (dB)	Ant Pos (cm)	Table Pos (deg)	Type
1			50.370	30.252	16.225	-9.748	40.000	14.027	100	130	QP
2			120.210	36.682	23.552	-6.818	43.500	13.130	100	158	QP
3			131.365	39.645	25.815	-3.855	43.500	13.830	100	96	QP
4			240.005	38.314	25.552	-7.686	46.000	12.762	100	249	QP
5		*	480.800	44.163	25.958	-1.837	46.000	18.205	100	293	QP
6			960.230	47.533	22.587	-6.467	54.000	24.946	100	65	QP

Note: Measure Level (dBuV/m) = Reading Level (dBuV) + Factor (dB)

Factor (dB) = Cable Loss (dB) + Antenna Factor (dB/m).

Site: AC1	Time: 2016/03/07 - 17:49
Limit: FCC_Part15.109_RE(3m)_Class B	Engineer: Line Chen
Probe: BBHA9120D_1-18GHz	Polarity: Horizontal
EUT: E-reader	Power: AC 120V/60Hz
Test Mode 1	

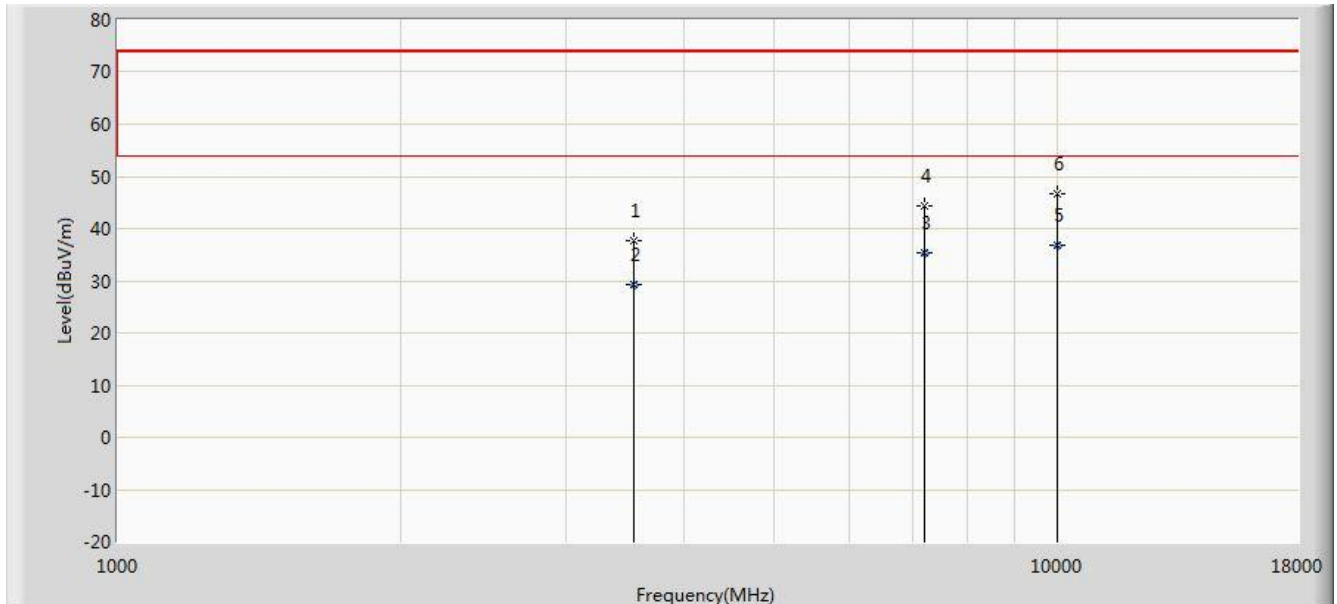

No	Flag	Mark	Frequency (MHz)	Measure Level (dBuV/m)	Reading Level (dBuV)	Over Limit (dB)	Limit (dBuV/m)	Factor (dB)	Ant Pos (cm)	Table Pos (deg)	Type
1			3541.500	37.666	38.594	-36.334	74.000	-0.927	100	119	PK
2			3542.000	29.316	30.241	-24.684	54.000	-0.925	100	264	AV
3			7204.500	35.332	27.526	-18.668	54.000	7.806	100	81	AV
4			7205.000	44.266	36.461	-29.734	74.000	7.805	100	336	PK
5		*	9984.000	36.952	25.526	-17.048	54.000	11.426	100	147	AV
6			9984.500	46.711	35.286	-27.289	74.000	11.425	100	253	PK

Note: Measure Level (dBuV/m) = Reading Level (dBuV) + Factor (dB)

Factor (dB) = Cable Loss (dB) + Antenna Factor (dB/m) – Pre\_Amplifier Gain (dB).

Site: AC1	Time: 2016/03/07 - 17:49
Limit: FCC_Part15.109_RE(3m)_Class B	Engineer: Line Chen
Probe: BBHA9120D_1-18GHz	Polarity: Vertical
EUT: E-reader	Power: AC 120V/60Hz
Test Mode 1	

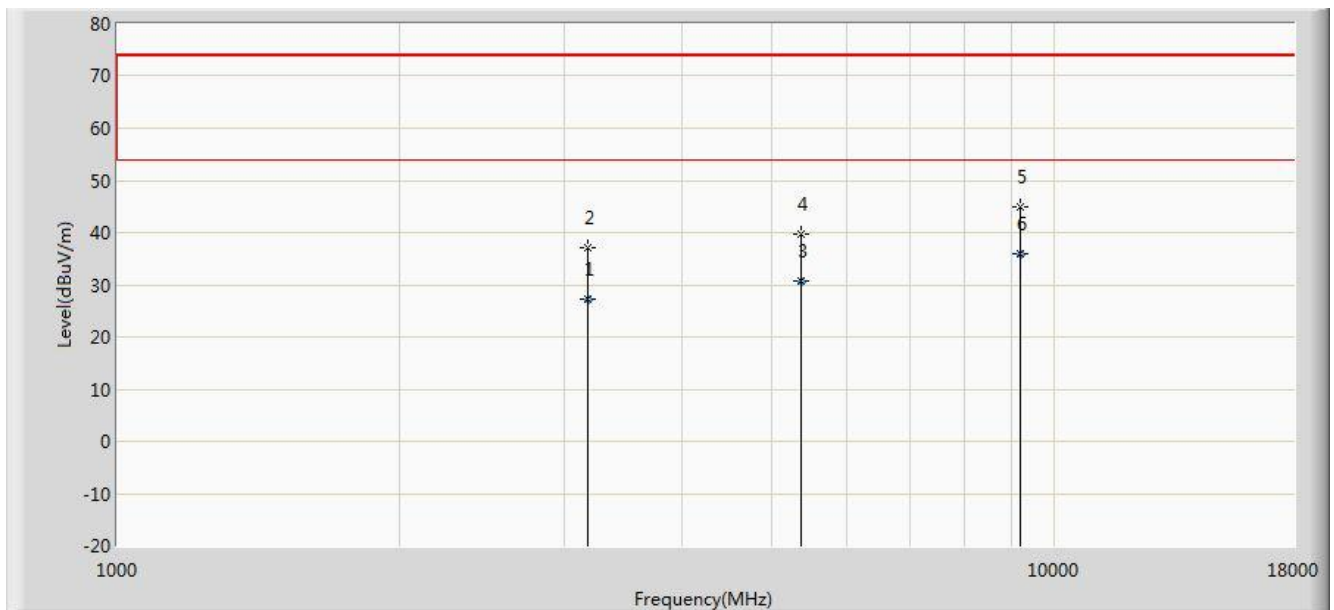

No	Flag	Mark	Frequency (MHz)	Measure Level (dBuV/m)	Reading Level (dBuV)	Over Limit (dB)	Limit (dBuV/m)	Factor (dB)	Ant Pos (cm)	Table Pos (deg)	Type
1			3175.500	27.358	28.917	-26.642	54.000	-1.559	100	52	PK
2			3176.000	37.062	38.622	-36.938	74.000	-1.560	100	332	AV
3			5360.000	30.650	27.628	-23.350	54.000	3.021	100	126	AV
4			5360.500	39.749	36.728	-34.251	74.000	3.022	100	324	PK
5			9177.000	44.917	34.946	-29.083	74.000	9.971	100	109	PK
6		*	9177.500	35.900	25.925	-18.100	54.000	9.976	100	56	AV

Note: Measure Level (dBuV/m) = Reading Level (dBuV) + Factor (dB)

Factor (dB) = Cable Loss (dB) + Antenna Factor (dB/m) – Pre\_Amplifier Gain (dB).

Site: AC1	Time: 2016/03/07 - 17:49
Limit: FCC_Part15.109_RE(3m)_Class B	Engineer: Line Chen
Probe: BBHA9120D_1-18GHz	Polarity: Horizontal
EUT: E-reader	Power: AC 120V/60Hz
Test Mode 2	

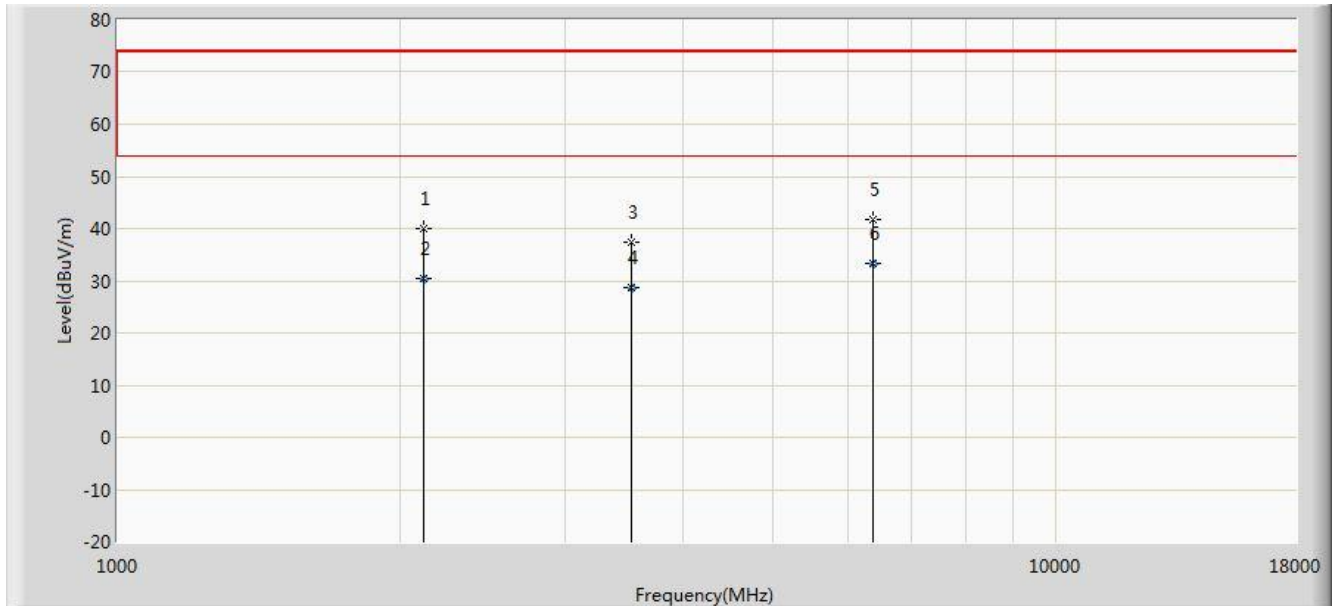

No	Flag	Mark	Frequency (MHz)	Measure Level (dBuV/m)	Reading Level (dBuV)	Over Limit (dB)	Limit (dBuV/m)	Factor (dB)	Ant Pos (cm)	Table Pos (deg)	Type
1			2122.000	40.077	44.544	-33.923	74.000	-4.467	100	88	PK
2			2122.500	30.559	35.020	-23.441	54.000	-4.461	100	266	AV
3			3533.000	37.367	38.341	-36.633	74.000	-0.974	100	60	PK
4			3533.500	28.553	29.525	-25.447	54.000	-0.971	100	185	AV
5			6372.000	41.721	36.456	-32.279	74.000	5.265	100	305	PK
6		*	6372.500	33.194	27.926	-20.806	54.000	5.268	100	117	AV

Note: Measure Level (dB $\mu$ V/m) = Reading Level (dB $\mu$ V) + Factor (dB)

Factor (dB) = Cable Loss (dB) + Antenna Factor (dB/m) – Pre\_Amplifier Gain (dB).

Site: AC1	Time: 2016/03/07 - 17:49
Limit: FCC_Part15.109_RE(3m)_Class B	Engineer: Line Chen
Probe: BBHA9120D_1-18GHz	Polarity: Vertical
EUT: E-reader	Power: AC 120V/60Hz
Test Mode 2	

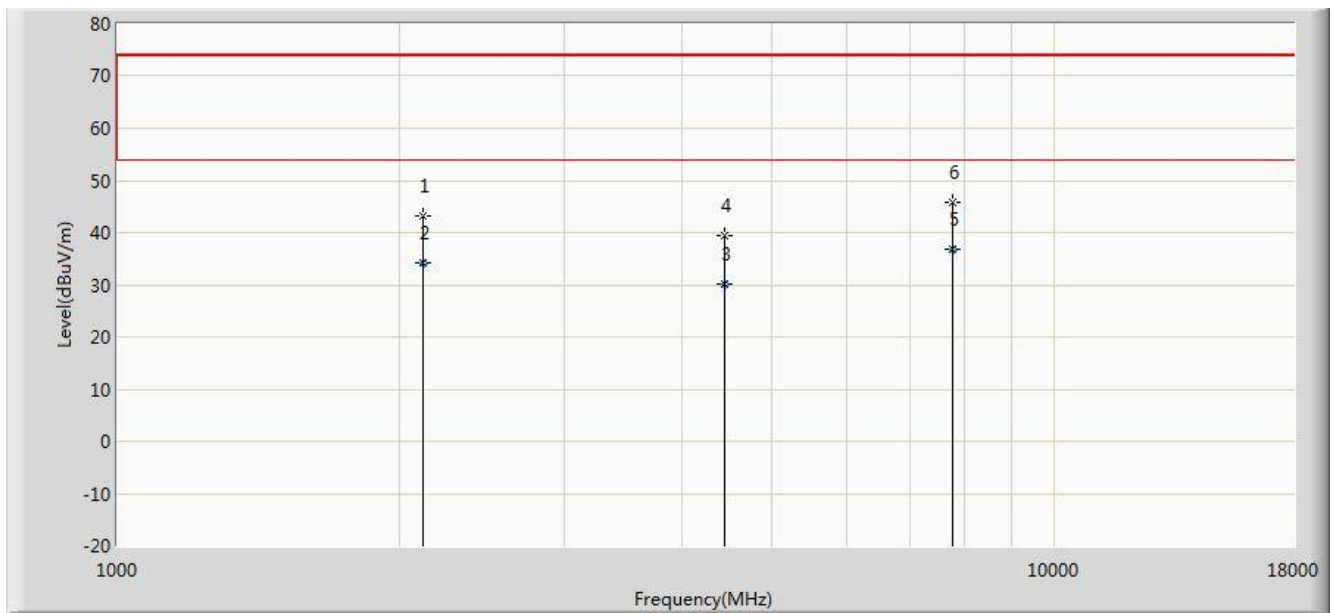

No	Flag	Mark	Frequency (MHz)	Measure Level (dBuV/m)	Reading Level (dBuV)	Over Limit (dB)	Limit (dBuV/m)	Factor (dB)	Ant Pos (cm)	Table Pos (deg)	Type
1			2122.000	43.131	47.598	-30.869	74.000	-4.467	100	90	PK
2			2122.500	34.068	38.529	-19.932	54.000	-4.461	100	258	AV
3			4450.500	30.225	28.718	-23.775	54.000	1.508	100	116	AV
4			4451.000	39.446	37.937	-34.554	74.000	1.509	100	175	PK
5		*	7791.000	36.832	28.518	-17.168	54.000	8.315	100	341	AV
6			7791.500	45.723	37.406	-28.277	74.000	8.318	100	75	PK

Note: Measure Level (dBuV/m) = Reading Level (dBuV) + Factor (dB)

Factor (dB) = Cable Loss (dB) + Antenna Factor (dB/m) – Pre\_Amplifier Gain (dB).

————— The End —————