



MEASUREMENT REPORT

FCC Part 15B

FCC ID: XR3-MAX
APPLICANT: ONYX INTERNATIONAL INC.

Application Type: Certification
Product: E-reader
Model No.: Max, Max Carta, Max Carta Plus, Max Pro
FCC Rule Part(s): FCC Part 15 Subpart B: 2016
Test Procedure(s): ANSI C63.4: 2014
Test Date: June 17 ~ July 13, 2016

Reviewed By : Robin Wu
(Robin Wu)
Approved By : Marlin Chen
(Marlin Chen)



The test results relate only to the samples tested.

This equipment has been shown to be capable of compliance with the applicable technical standards as indicated in the measurement report and was tested in accordance with the measurement procedures specified in ANSI C63.4-2014. Test results reported herein relate only to the item(s) tested.

The test report shall not be reproduced except in full without the written approval of MRT Technology (Suzhou) Co., Ltd.

Revision History

Report No.	Version	Description	Issue Date
1606RSU02104	Rev. 01	Initial report	08-05-2016
1606RSU02104	Rev. 02	Added serial number	08-09-2016

CONTENTS

Description	Page
§2.1033 General Information	4
1. INTRODUCTION	5
1.1. Scope	5
1.2. MRT Test Location.....	5
2. PRODUCT INFORMATION	6
2.1. Product Specification Subjective to this Report.....	6
2.2. Test Mode	6
2.3. Test Configuration	7
2.4. Test System Details.....	9
2.5. Test Software	9
2.6. EMI Suppression Device(s)/Modifications.....	9
3. DESCRIPTION OF TEST	10
3.1. Evaluation Procedure	10
3.2. AC Line Conducted Emissions	10
3.3. Radiated Emissions	11
4. TEST EQUIPMENT CALIBRATION DATE	12
5. MEASUREMENT UNCERTAINTY	13
6. TEST RESULT	14
6.1. Summary	14
6.2. Conducted Emission Measurement	15
6.2.1. Test Limit	15
6.2.2. Test Setup.....	15
6.2.3. Test Result of Conducted Emissions.....	16
6.3. Radiated Emission Measurement	20
6.3.1. Test Limit	20
6.3.2. Test Setup.....	20
6.3.3. Test Result of Radiated Emissions.....	22

§2.1033 General Information

Applicant:	ONYX INTERNATIONAL INC.
Applicant Address:	Room 102, 3rd Floor, No. 38 HongLou Road, LiWan District, GuangZhou, China
Manufacturer:	ONYX INTERNATIONAL INC.
Manufacturer Address:	Room 102, 3rd Floor, No. 38 HongLou Road, LiWan District, GuangZhou, China
Test Site:	MRT Technology (Suzhou) Co., Ltd
Test Site Address:	D8 Building, Youxin Industrial Park, No.2 Tian'edang Rd., Wuzhong Economic Development Zone, Suzhou, China
MRT FCC Registration No.:	809388
FCC ID:	XR3-MAX
Model No.:	Max, Max Carta, Max Carta Plus, Max Pro
Test Device Serial No.:	N/A <input type="checkbox"/> Production <input checked="" type="checkbox"/> Pre-Production <input type="checkbox"/> Engineering

Test Facility / Accreditations

Measurements were performed at MRT Laboratory located in Tian'edang Rd., Suzhou, China.

- MRT facility is a FCC registered (MRT Reg. No. 809388) test facility with the site description report on file and has met all the requirements specified in Section 2.948 of the FCC Rules.
- MRT facility is an IC registered (MRT Reg. No. 11384A-1) test laboratory with the site description on file at Industry Canada.
- MRT facility is a VCCI registered (R-4179, G-814, C-4664, T-2206) test laboratory with the site description on file at VCCI Council.
- MRT Lab is accredited to ISO 17025 by the American Association for Laboratory Accreditation (A2LA) under the American Association for Laboratory Accreditation Program (A2LA Cert. No. 3628.01) in EMC, Telecommunications and Radio testing for FCC, Industry Canada, EU and TELEC Rules.



1. INTRODUCTION

1.1. Scope

Measurement and determination of electromagnetic emissions (EMC) of radio frequency devices including intentional and/or unintentional radiators for compliance with the technical rules and regulations of the Federal Communications Commission and the Industry Canada Certification and Engineering Bureau.

1.2. MRT Test Location

The map below shows the location of the MRT LABORATORY, its proximity to the Taihu Lake. These measurement tests were conducted at the MRT Technology (Suzhou) Co., Ltd. Facility located at D8 Building, Youxin Industrial Park, No.2 Tian'edang Rd., Wuzhong Economic Development Zone, Suzhou, China. The detailed description of the measurement facility was found to be in compliance with the requirements of § 2.948 according to ANSI C63.4-2009 on September 30, 2013.



2. PRODUCT INFORMATION

2.1. Product Specification Subjective to this Report

Product Name	E-reader
Model No.	Max, Max Carta, Max Carta Plus, Max Pro
Wi-Fi Specification	802.11b/g/n-HT20
Bluetooth Version	v3.0 + HS, v4.0
Components	
Adapter	M/N: HKC0055010-2D INPUT: 100-240V ~ 50/60Hz, 0.2A OUTPUT: 5Vdc, 1.0A

2.2. Test Mode

Mode 1: Charging + Reading + Playing Music
Mode 2: USB Copy

2.3. Test Configuration

The EUT was tested per the guidance FCC Part 15 Subpart B: 2016 and ANSI C63.4: 2014 was used to reference the appropriate EUT setup for radiated spurious emissions testing and AC line conducted testing.

Connection Diagram (Mode 1)

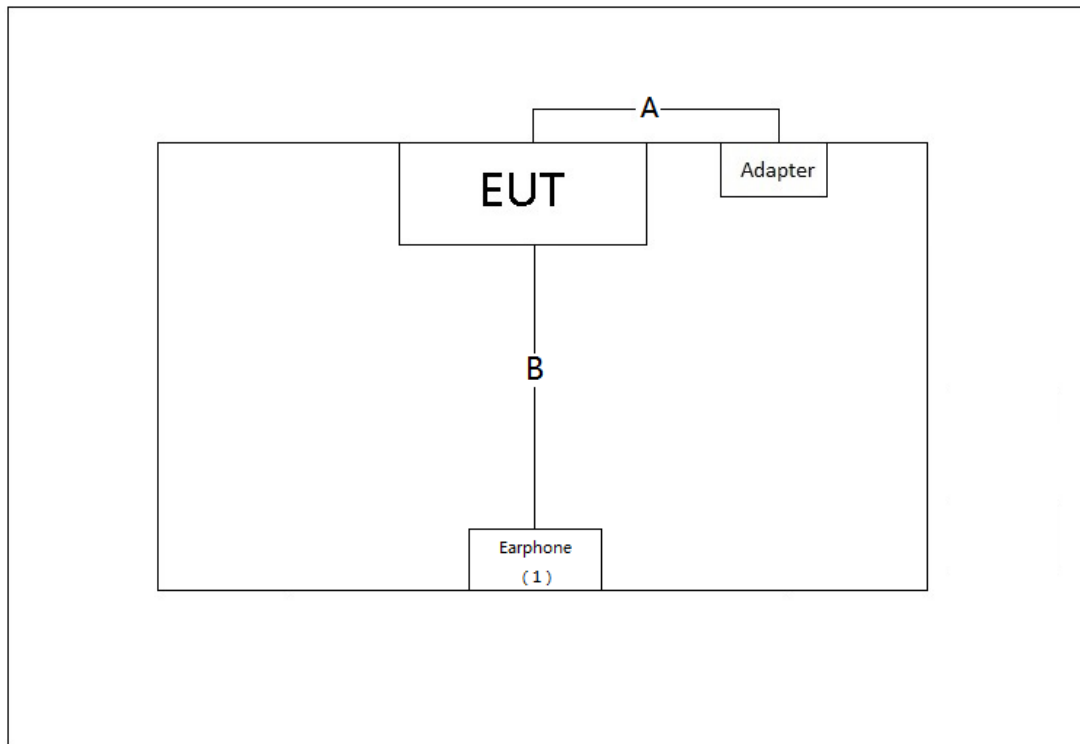

Connection Diagram (Mode 2)

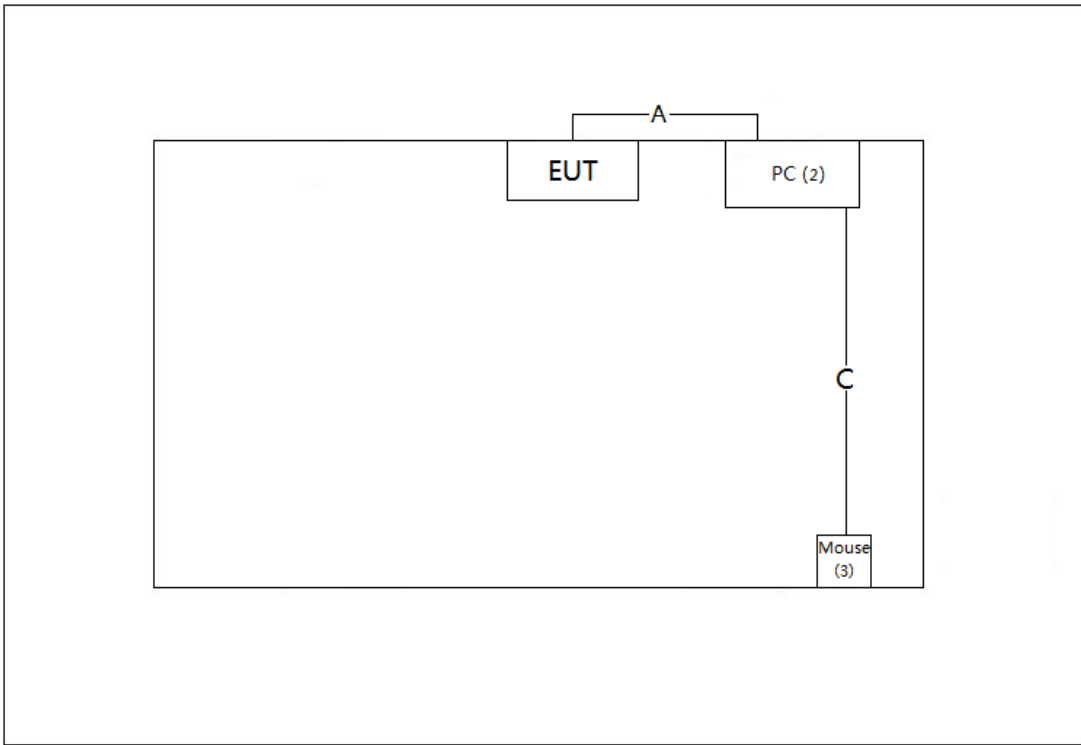

Signal Cable Type		Signal Cable Description
A	USB Cable	Shielded, 0.5m
B	Earphone Cable	Non-Shielded, 1.2m
C	USB Cable	Shielded, 1.8m

2.4. Test System Details

The types for all equipments, plus descriptions of all cables used in the tested system (including inserted cards) are:

Product	Manufacturer	Model No.	Serial No.	Power Cord
1	Earphone	Taijie	N/A	N/A
2	Notebook	Lenovo	E430c	MP-4CFX213/10
3	USB Mouse	DELL	MS111-T	N/A

2.5. Test Software

1	Setup the EUT and simulators as shown on above.
2	Turn on the power of all equipment.
3	(1), Making EUT working on "Charging + Reading" Mode + Playing Music. (2), Making EUT working on "USB Copy" Mode.

2.6. EMI Suppression Device(s)/Modifications

No EMI suppression device(s) were added and/or no modifications were made during testing.

3. DESCRIPTION OF TEST

3.1. Evaluation Procedure

The measurement procedures described in the American National Standard for Methods of Measurement of Radio-Noise Emission from Low-Voltage Electrical Equipment in the Range of 9kHz to 40GHz (ANSI C63.4-2014) was used in the measurement of the **E-reader**

Deviation from measurement procedure.....None

3.2. AC Line Conducted Emissions

The line-conducted facility is located inside an 8'x4'x4' shielded enclosure. A 1m x 2m wooden table 80cm high is placed 40cm away from the vertical wall and 80cm away from the sidewall of the shielded room. Two 10kHz-30MHz, 50Ω/50uH Line-Impedance Stabilization Networks (LISNs) are bonded to the shielded room floor. Power to the LISNs is filtered by external high-current high-insertion loss power line filters. These filters attenuate ambient signal noise from entering the measurement lines. These filters are also bonded to the shielded enclosure.

The EUT is powered from one LISN and the support equipment is powered from the second LISN. If the EUT is a DC-powered device, power will be derived from the source power supply it normally will be powered from and this supply line(s) will be connected to the second LISN. All interconnecting cables more than 1 meter were shortened to a 1 meter length by non-inductive bundling (serpentine fashion) and draped over the back edge of the test table. All cables were at least 40cm above the horizontal reference ground-plane. Power cables for support equipment were routed down to the second LISN while ensuring that that cables were not draped over the second LISN.

Sufficient time for the EUT, support equipment, and test equipment was allowed in order for them to warm up to their normal operating condition. The RF output of the LISN was connected to the receiver and exploratory measurements were made to determine the frequencies producing the maximum emission from the EUT. The receiver was scanned from 150 kHz to 30 MHz. The detector function was set to peak mode for exploratory measurements while the bandwidth of the analyzer was set to 9 kHz. The EUT, support equipment, and interconnecting cables were arranged and manipulated to maximize each emission. Each emission was also maximized by varying: power lines, the mode of operation or resolution, clock or data exchange speed, scrolling H pattern to the EUT and/or support equipment whichever determined the worst-case emission. Once the worst case emissions have been identified, the one EUT cable configuration/arrangement and mode of operation that produced these emissions are used for final measurements on the same test site. Line conducted emissions test results are shown in Section 6.2.

3.3. Radiated Emissions

The radiated test facilities consisted of an indoor 3 meter semi-anechoic chamber used for final measurements and exploratory measurements, when necessary. The measurement area is contained within the semi-anechoic chamber which is shielded from any ambient interference. For measurements above 1GHz absorbers are arranged on the floor between the turn table and the antenna mast in such a way so as to maximize the reduction of reflections. For measurements below 1GHz, the absorbers are removed. An MF Model 210SS turntable is used for radiated measurement. It is a continuously rotatable, remote controlled, metallic turntable and 2 meters (6.56 ft.) in diameter. The turn table is flush with the raised floor of the chamber in order to maintain its function as a ground plane. An 80cm high PVC support structure is placed on top of the turntable.

For all measurements, the spectrum was scanned through all EUT azimuths and from 1 to 4 meter receive antenna height using a broadband antenna from 30 MHz up to the upper frequency shown in 15.33(b)(1) depending on the highest frequency generated or used in the device or on which the device operates or tunes. For frequencies above 1GHz, linearly polarized double ridge horn antennas were used. For frequencies below 30 MHz, a calibrated loop antenna was used. When exploratory measurements were necessary, they were performed at 1 meter test distance inside the semi-anechoic chamber using broadband antennas, broadband amplifiers, and spectrum analyzers to determine the frequencies and modes producing the maximum emissions. Sufficient time for the EUT, support equipment, and test equipment was allowed in order for them to warm up to their normal operating condition. The test set-up was placed on top of the 0.8 meter high, 1 x 1.5 meter table. The EUT, support equipment, and interconnecting cables were arranged and manipulated to maximize each emission. Appropriate precaution was taken to ensure that all emissions from the EUT were maximized and investigated. The system configuration, mode of operation, if applicable, turntable azimuth, and receive antenna height was noted for each frequency found.

Final measurements were made in the semi-anechoic chamber using calibrated, linearly polarized broadband and horn antennas. The test setup was configured to the setup that produced the worst case emissions. The spectrum analyzer was set to investigate all frequencies required for testing to compare the highest radiated disturbances with respect to the specified limits. The turntable containing the EUT was rotated through 360 degrees and the height of the receive antenna was varied 1 to 4 meters and stopped at the azimuth and height producing the maximum emission. Each emission was maximized by changing the orientation of the EUT through three orthogonal planes and changing the polarity of the receive antenna, whichever produced the worst-case emissions. According to 3dB beam-width of horn antenna, the horn antenna should be always directed to the EUT when rising height.

4. TEST EQUIPMENT CALIBRATION DATE

Conducted Emissions – SR2

Instrument	Manufacturer	Type No.	Serial No.	Cali. Interval	Cali. Due Date
EMI Test Receiver	R&S	ESR7	101209	1 year	2016/11/03
Two-Line V-Network	R&S	ENV216	101683	1 year	2016/11/03
Two-Line V-Network	R&S	ENV216	101684	1 year	2016/11/03
Temperature/Humidity Meter	Yuhuaze	HTC-2	MRTSUE06182	1 year	2016/12/20

Radiated Emission – AC2

Instrument	Manufacturer	Type No.	Serial No.	Cali. Interval	Cali. Due Date
MXE EMI Receiver	Agilent	N9038A	MY51210182	1 year	2016/08/03
Microwave System Amplifier	Agilent	83017A	MY53270040	1 year	2017/03/29
TRILOG Antenna	Schwarzbeck	VULB9162	9162-047	1 year	2016/11/07
Broad-Band Horn Antenna	Schwarzbeck	BBHA9120D	9120D-1167	1 year	2016/11/07
Digital Thermometer & Hygromete	MingGao	ETH529	MRTSUE06170	1 year	2016/11/30

Software	Version	Function
e3	V8.3.5	EMI Test Software

5. MEASUREMENT UNCERTAINTY

Where relevant, the following test uncertainty levels have been estimated for tests performed on the EUT as specified in CISPR 16-4-2. This uncertainty represents an expanded uncertainty expressed at approximately the 95% confidence level using a coverage factor of $k = 2$.

AC Conducted Emission Measurement – SR2
Measuring Uncertainty for a Level of Confidence of 95% ($U=2Uc(y)$): 150kHz~30MHz: 3.5dB
Radiated Emission Measurement – AC2
Measuring Uncertainty for a Level of Confidence of 95% ($U=2Uc(y)$): Horizontal: 30MHz~1GHz: 4.07dB 1GHz~18GHz: 4.16 dB Vertical: 30MHz~1GHz: 4.18 dB 1GHz~18GHz: 4.76 dB

6. TEST RESULT

6.1. Summary

Company Name: ONYX INTERNATIONAL INC.

Test Mode: Mode 1: Charging + Reading + Playing Music

Mode 2: USB Copy

FCC Part Section(s)	Test Description	Test Result
15.107	Conducted Emissions	Pass
15.109	Radiated Emissions	Pass

6.2. Conducted Emission Measurement

6.2.1. Test Limit

FCC Part 15.107 Limits		
Frequency (MHz)	QP (dB μ V)	AV (dB μ V)
0.15 - 0.50	66 - 56	56 - 46
0.50 - 5.0	56	46
5.0 - 30	60	50

Note 1: The lower limit shall apply at the transition frequencies.

Note 2: The limit decreases linearly with the logarithm of the frequency in the range 0.15MHz to 0.5MHz.

6.2.2. Test Setup

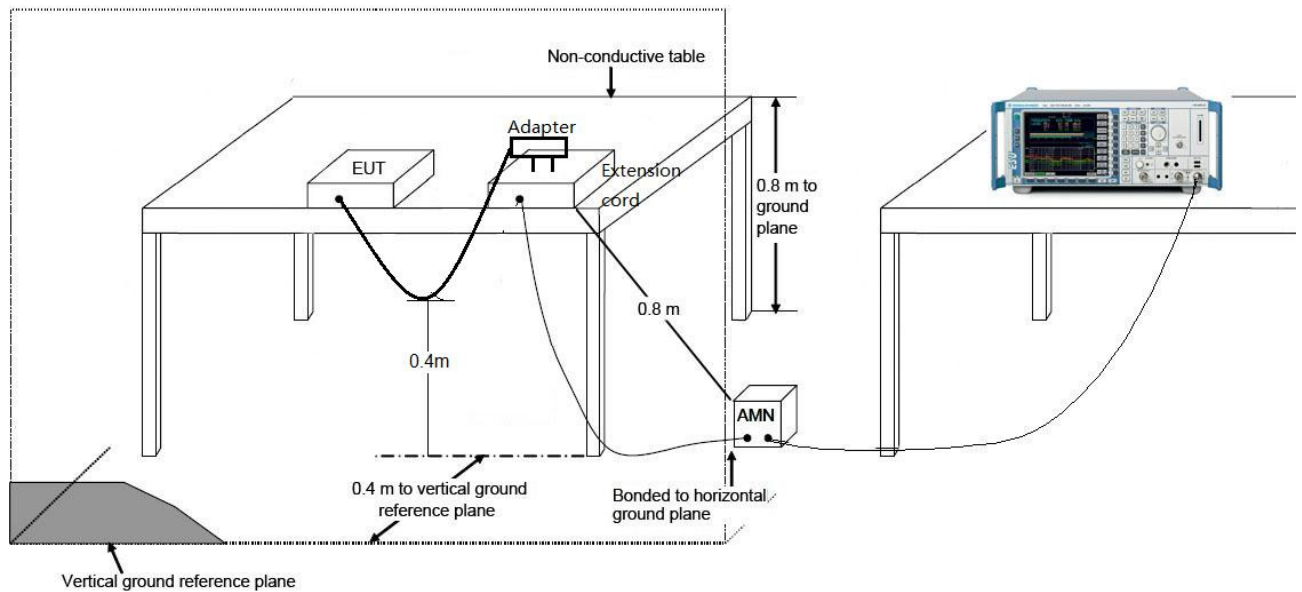

6.2.3. Test Result of Conducted Emissions

Site: SR2	Time: 2016/06/21 - 16:57
Limit: FCC_Part15.107_CE_Class B	Engineer: Line Chen
Probe: ENV216_101683_Filter On	Polarity: Line
EUT: E-reader	Power: AC 120V/60Hz
Test Mode 1	

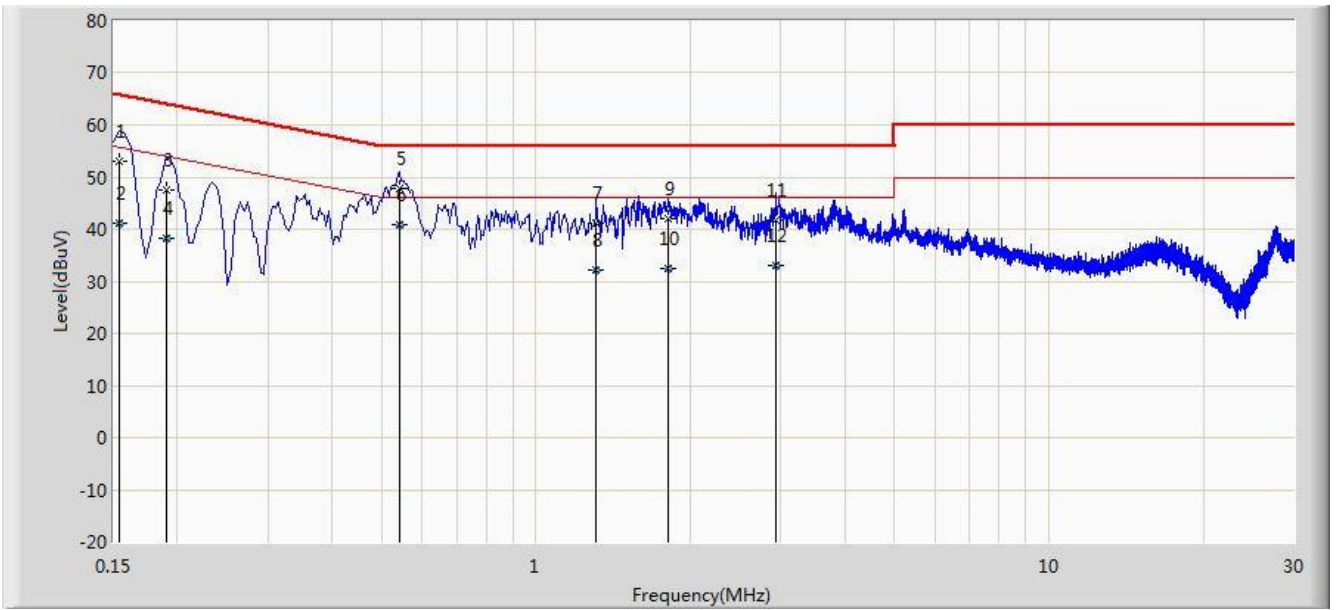

No	Flag	Mark	Frequency (MHz)	Measure Level (dBuV)	Reading Level (dBuV)	Over Limit (dB)	Limit (dBuV)	Factor (dB)	Type
1			0.154	53.141	42.401	-12.641	65.781	10.740	QP
2			0.154	41.282	30.543	-14.499	55.781	10.740	AV
3			0.190	47.434	37.405	-16.603	64.037	10.029	QP
4			0.190	38.388	28.359	-15.649	54.037	10.029	AV
5			0.542	47.905	37.760	-8.095	56.000	10.145	QP
6		*	0.542	40.828	30.683	-5.172	46.000	10.145	AV
7			1.310	41.240	31.343	-14.760	56.000	9.897	QP
8			1.310	32.156	22.259	-13.844	46.000	9.897	AV
9			1.813	41.920	32.043	-14.080	56.000	9.878	QP
10			1.813	32.409	22.532	-13.591	46.000	9.878	AV
11			2.931	41.632	31.779	-14.368	56.000	9.854	QP
12			2.931	33.068	23.214	-12.932	46.000	9.854	AV

Note: Measure Level (dB μ V) = Reading Level (dB μ V) + Factor (dB)

Factor (dB) = Cable Loss (dB) + LISN Factor (dB).

Site: SR2	Time: 2016/06/21 - 17:03
Limit: FCC_Part15.107_CE_Class B	Engineer: Line Chen
Probe: ENV216_101683_Filter On	Polarity: Neutral
EUT: E-reader	Power: AC 120V/60Hz
Test Mode 1	

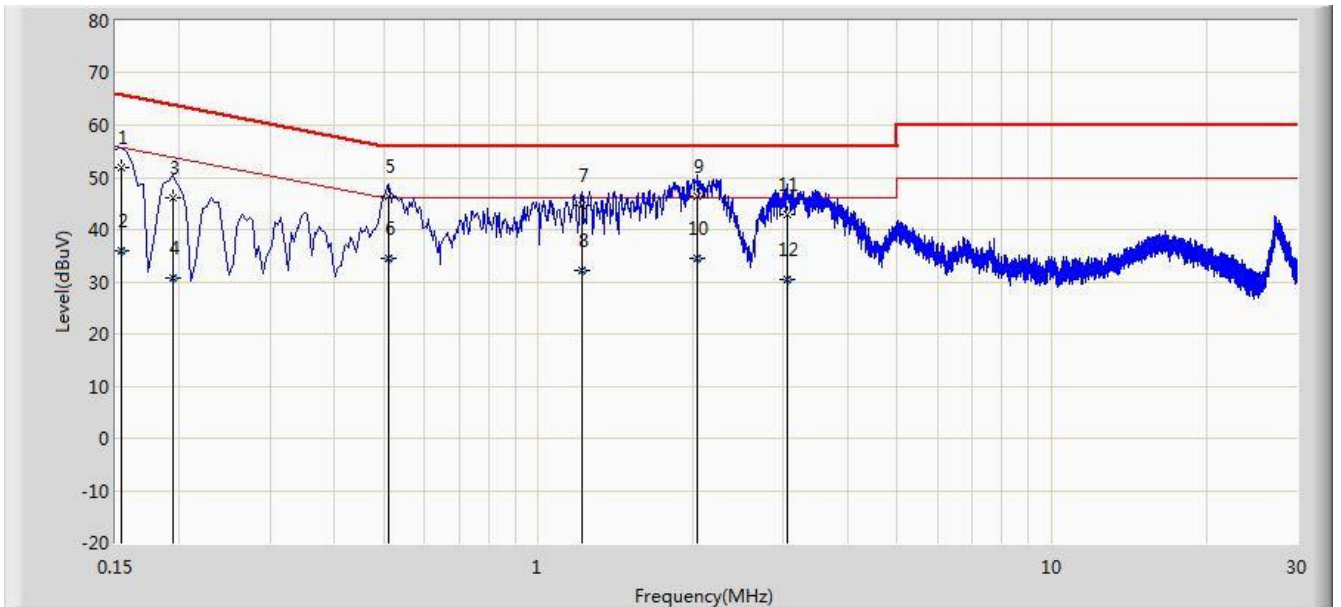

No	Flag	Mark	Frequency (MHz)	Measure Level (dBuV)	Reading Level (dBuV)	Over Limit (dB)	Limit (dBuV)	Factor (dB)	Type
1			0.154	51.859	41.143	-13.923	65.781	10.716	QP
2			0.154	36.011	25.295	-19.771	55.781	10.716	AV
3			0.194	45.987	35.965	-17.877	63.864	10.021	QP
4			0.194	30.587	20.566	-23.276	53.864	10.021	AV
5		*	0.510	46.409	36.233	-9.591	56.000	10.176	QP
6			0.510	34.419	24.242	-11.581	46.000	10.176	AV
7			1.218	44.676	34.774	-11.324	56.000	9.901	QP
8			1.218	32.100	22.199	-13.900	46.000	9.901	AV
9			2.042	46.372	36.500	-9.628	56.000	9.872	QP
10			2.042	34.476	24.604	-11.524	46.000	9.872	AV
11			3.058	42.921	33.055	-13.079	56.000	9.866	QP
12			3.058	30.403	20.536	-15.597	46.000	9.866	AV

Note: Measure Level (dBμV) = Reading Level (dBμV) + Factor (dB)

Factor (dB) = Cable Loss (dB) + LISN Factor (dB).

Site: SR2	Time: 2016/06/22 - 09:36
Limit: FCC_Part15.107_CE_Class B	Engineer: Line Chen
Probe: ENV216_101683_Filter On	Polarity: Line
EUT: E-reader	Power: AC 120V/60Hz
Test Mode 2	

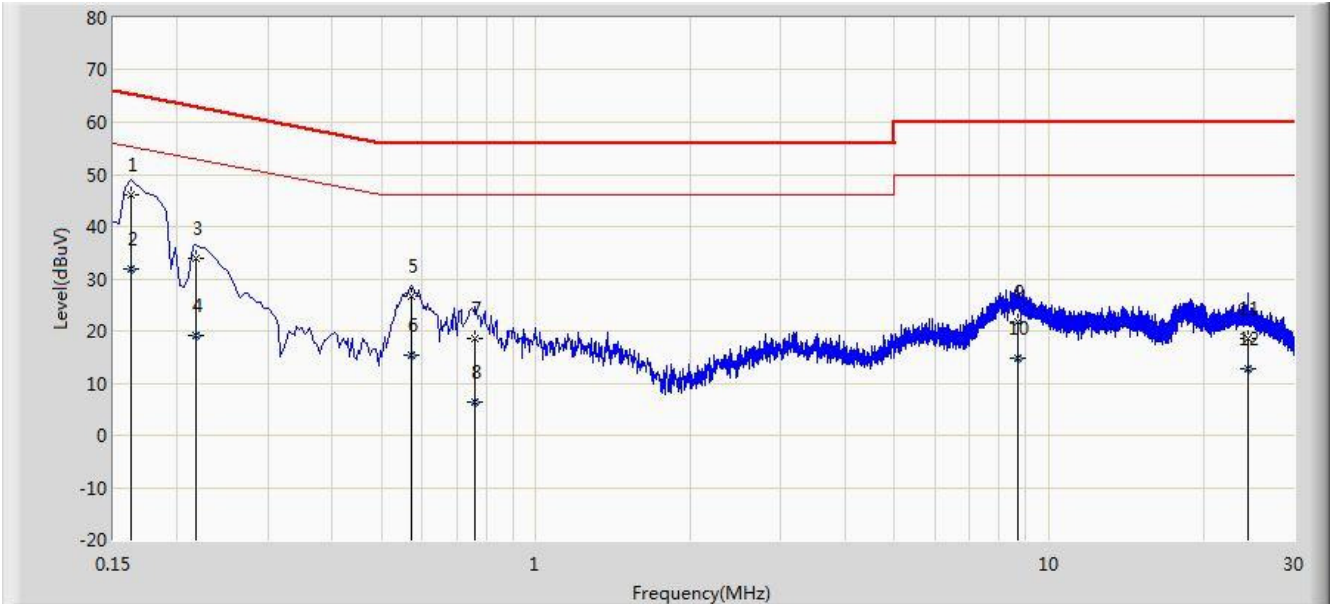

No	Flag	Mark	Frequency (MHz)	Measure Level (dBuV)	Reading Level (dBuV)	Over Limit (dB)	Limit (dBuV)	Factor (dB)	Type
1		*	0.162	46.048	35.951	-19.313	65.361	10.097	QP
2			0.162	31.862	21.765	-23.498	55.361	10.097	AV
3			0.218	33.987	24.042	-28.908	62.895	9.945	QP
4			0.218	19.008	9.063	-33.887	52.895	9.945	AV
5			0.570	26.701	16.571	-29.299	56.000	10.130	QP
6			0.570	15.441	5.311	-30.559	46.000	10.130	AV
7			0.762	18.500	8.469	-37.500	56.000	10.031	QP
8			0.762	6.497	-3.534	-39.503	46.000	10.031	AV
9			8.670	21.797	11.619	-38.203	60.000	10.178	QP
10			8.670	14.806	4.627	-35.194	50.000	10.178	AV
11			24.414	18.692	8.484	-41.308	60.000	10.208	QP
12			24.414	12.890	2.682	-37.110	50.000	10.208	AV

Note: Measure Level (dBμV) = Reading Level (dBμV) + Factor (dB)

Factor (dB) = Cable Loss (dB) + LISN Factor (dB).

Site: SR2	Time: 2016/06/22 - 09:40
Limit: FCC_Part15.107_CE _ Class B	Engineer: Line Chen
Probe: ENV216_101683_Filter On	Polarity: Neutral
EUT: E-reader	Power: AC 120V/60Hz
Test Mode 2	

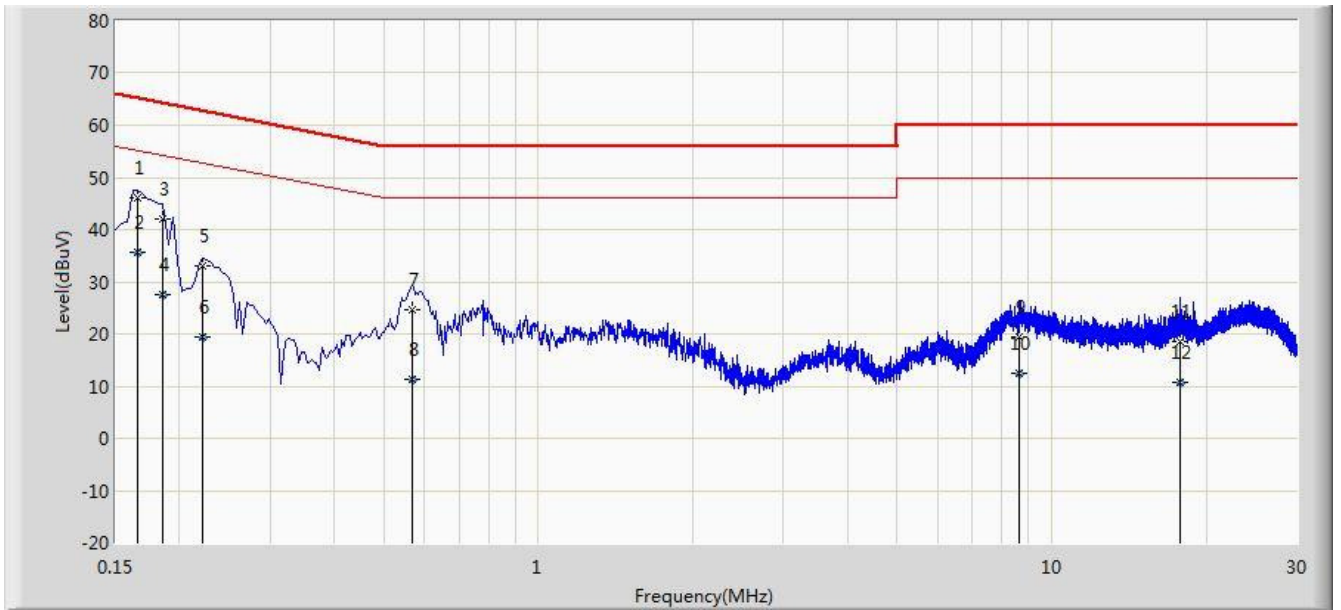

No	Flag	Mark	Frequency (MHz)	Measure Level (dBuV)	Reading Level (dBuV)	Over Limit (dB)	Limit (dBuV)	Factor (dB)	Type
1		*	0.166	46.137	36.066	-19.021	65.158	10.071	QP
2			0.166	35.758	25.687	-19.400	55.158	10.071	AV
3			0.186	42.162	32.127	-22.051	64.213	10.035	QP
4			0.186	27.558	17.523	-26.656	54.213	10.035	AV
5			0.222	32.942	22.962	-29.802	62.744	9.980	QP
6			0.222	19.547	9.567	-33.197	52.744	9.980	AV
7			0.566	24.502	14.352	-31.498	56.000	10.150	QP
8			0.566	11.235	1.086	-34.765	46.000	10.150	AV
9			8.650	19.279	9.082	-40.721	60.000	10.197	QP
10			8.650	12.495	2.298	-37.505	50.000	10.197	AV
11			17.746	18.464	8.331	-41.536	60.000	10.133	QP
12			17.746	10.712	0.579	-39.288	50.000	10.133	AV

Note: Measure Level (dBμV) = Reading Level (dBμV) + Factor (dB)

Factor (dB) = Cable Loss (dB) + LISN Factor (dB).

6.3. Radiated Emission Measurement

6.3.1. Test Limit

FCC Part 15.109 Limits		
Frequency (MHz)	Distance (m)	Level (dB μ V/m)
30 - 88	3	40
88 - 216	3	43.5
216 - 960	3	46
Above 960	3	54

Note 1: The lower limit shall apply at the transition frequency.

Note 2: Distance refers to the distance in meters between the measuring instrument antenna and the closed point of any part of the device or system.

Note 3: E field strength (dB μ V/m) = 20 log E field strength (uV/m)

6.3.2. Test Setup

30MHz ~ 1GHz Test Setup:

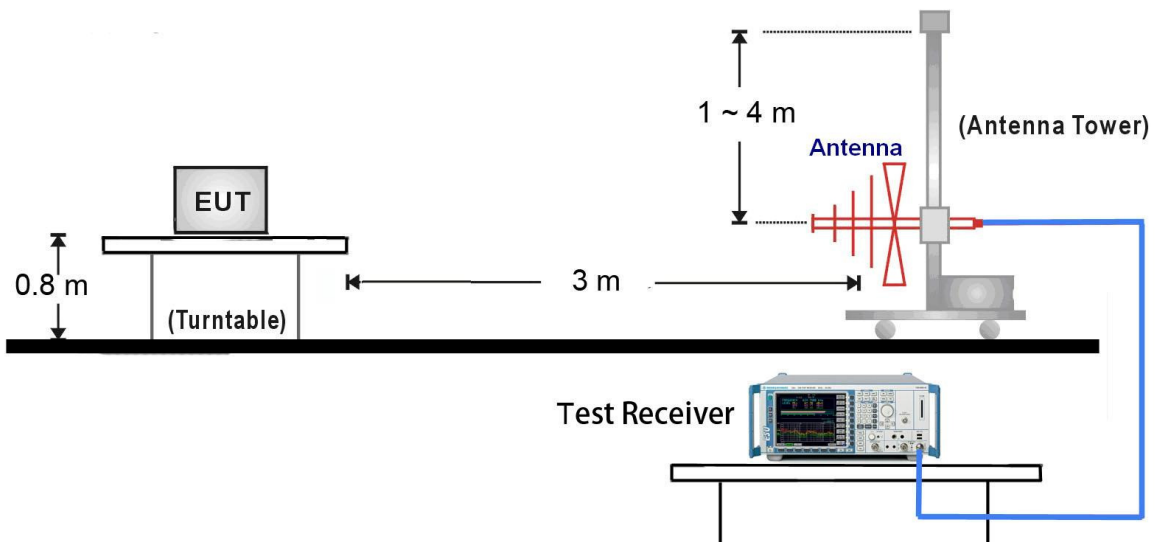

1GHz ~18GHz Test Setup:

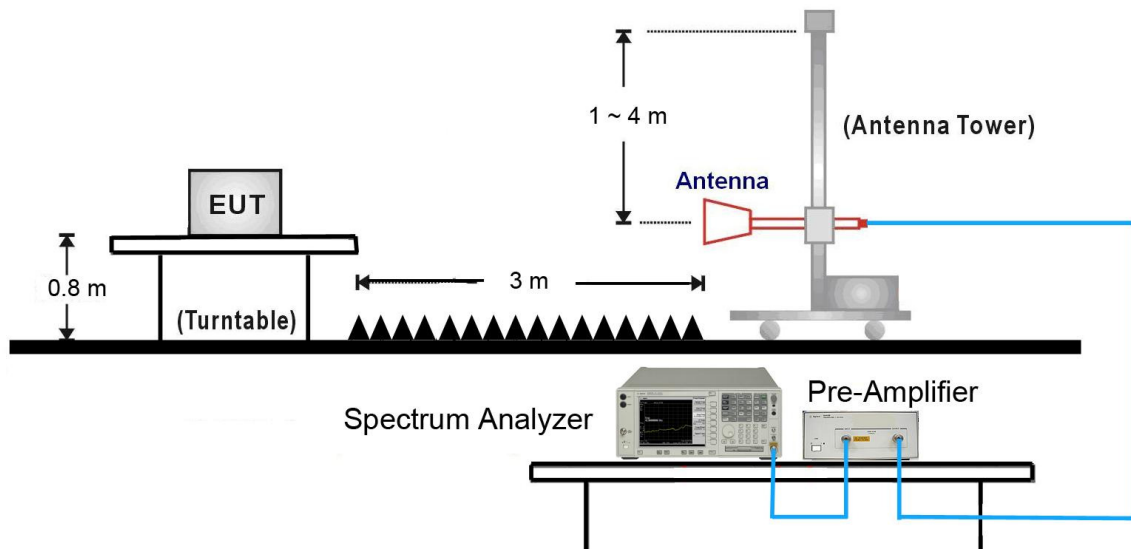

6.3.3. Test Result of Radiated Emissions

Site: AC2	Time: 2016/07/12 - 16:51
Limit: FCC_Part15.109_RE(3m)_Class B	Engineer: Line Chen
Probe: VULB9162_0.03-8GHz	Polarity: Horizontal
EUT: E-reader	Power: AC 120V/60Hz
Test Mode 1	

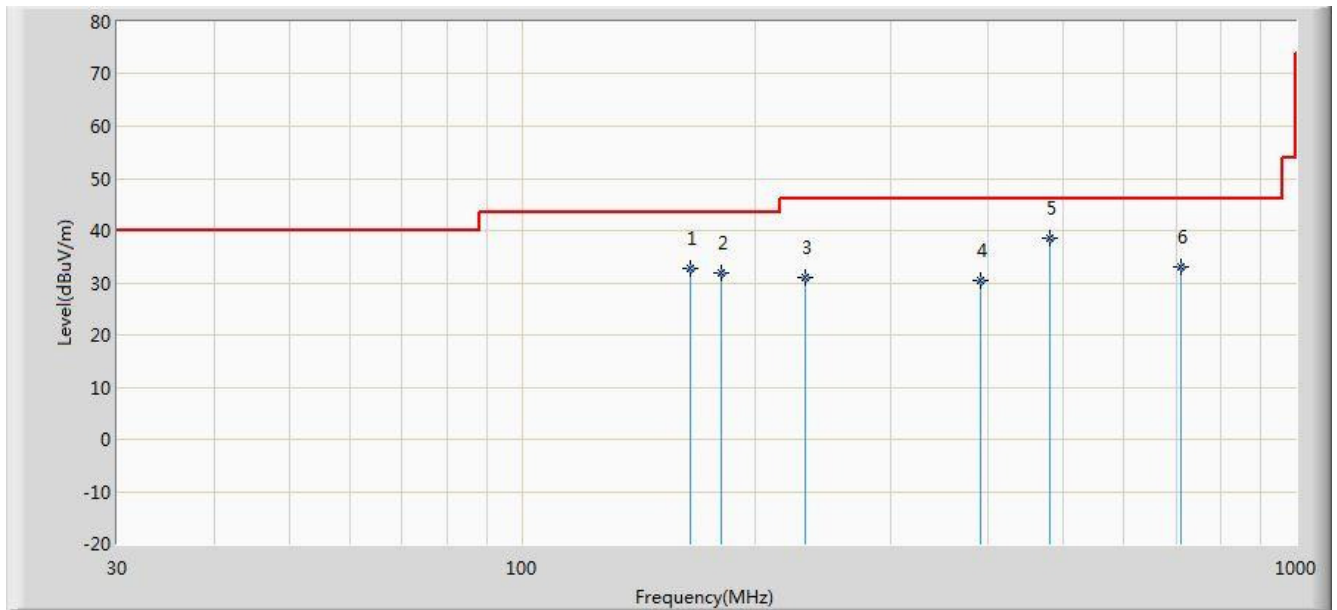

No	Flag	Mark	Frequency (MHz)	Measure Level (dBuV/m)	Reading Level (dBuV)	Over Limit (dB)	Limit (dBuV/m)	Factor (dB)	Ant Pos (cm)	Table Pos (deg)	Type
1			165.315	32.833	22.782	-10.667	43.500	10.051	100	107	QP
2			181.320	31.827	20.790	-11.673	43.500	11.037	100	201	QP
3			232.245	30.932	17.771	-15.068	46.000	13.161	100	193	QP
4			390.840	30.522	13.997	-15.478	46.000	16.526	100	177	QP
5		*	480.080	38.668	20.671	-7.332	46.000	17.997	100	335	QP
6			709.000	33.005	11.261	-12.995	46.000	21.744	100	281	QP

Note: Measure Level (dBuV/m) = Reading Level (dBuV) + Factor (dB)

Factor (dB) = Cable Loss (dB) + Antenna Factor (dB/m).

Site: AC2	Time: 2016/07/12 - 16:51
Limit: FCC_Part15.109_RE(3m)_Class B	Engineer: Line Chen
Probe: VULB9162_0.03-8GHz	Polarity: Vertical
EUT: E-reader	Power: AC 120V/60Hz
Test Mode 1	

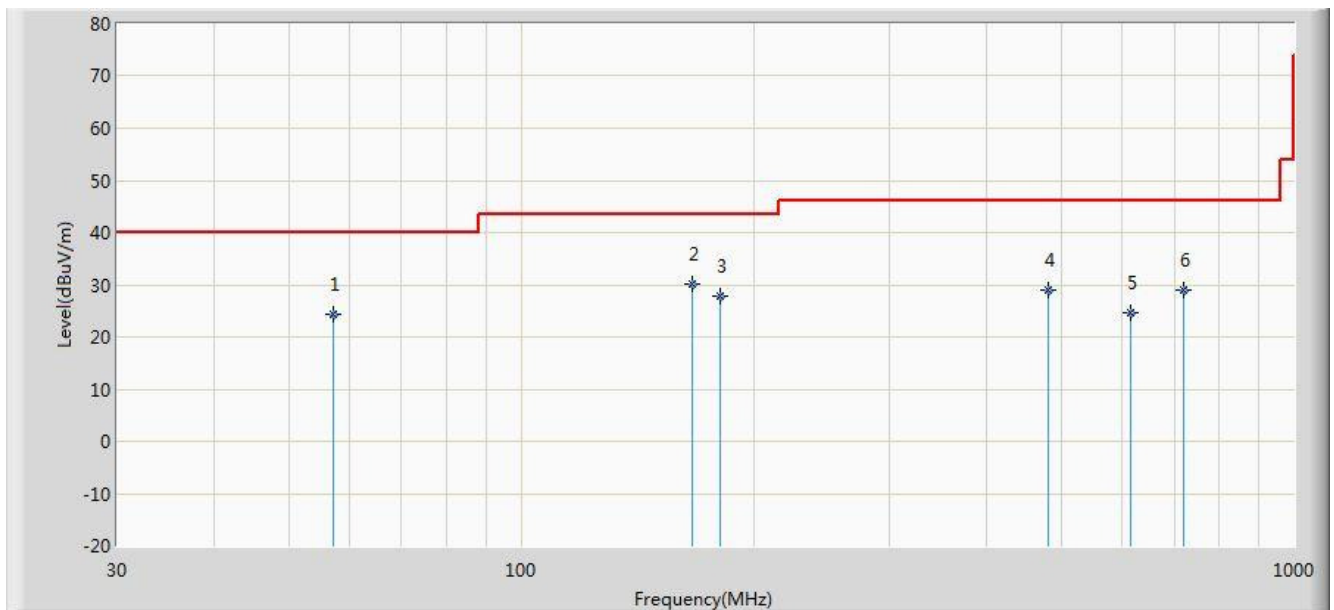

No	Flag	Mark	Frequency (MHz)	Measure Level (dBuV/m)	Reading Level (dBuV)	Over Limit (dB)	Limit (dBuV/m)	Factor (dB)	Ant Pos (cm)	Table Pos (deg)	Type
1			57.160	24.248	9.932	-15.752	40.000	14.316	100	118	QP
2		*	166.285	30.028	19.931	-13.472	43.500	10.097	100	102	QP
3			181.320	27.699	16.662	-15.801	43.500	11.037	100	209	QP
4			480.080	29.114	11.117	-16.886	46.000	17.997	100	347	QP
5			614.910	24.717	4.441	-21.283	46.000	20.276	100	67	QP
6			720.155	28.889	7.003	-17.111	46.000	21.886	100	278	QP

Note: Measure Level (dBuV/m) = Reading Level (dBuV) + Factor (dB)

Factor (dB) = Cable Loss (dB) + Antenna Factor (dB/m).

Site: AC2	Time: 2016/07/12 - 16:51
Limit: FCC_Part15.109_RE(3m)_Class B	Engineer: Line Chen
Probe: VULB9162_0.03-8GHz	Polarity: Horizontal
EUT: E-reader	Power: AC 120V/60Hz
Test Mode 2	

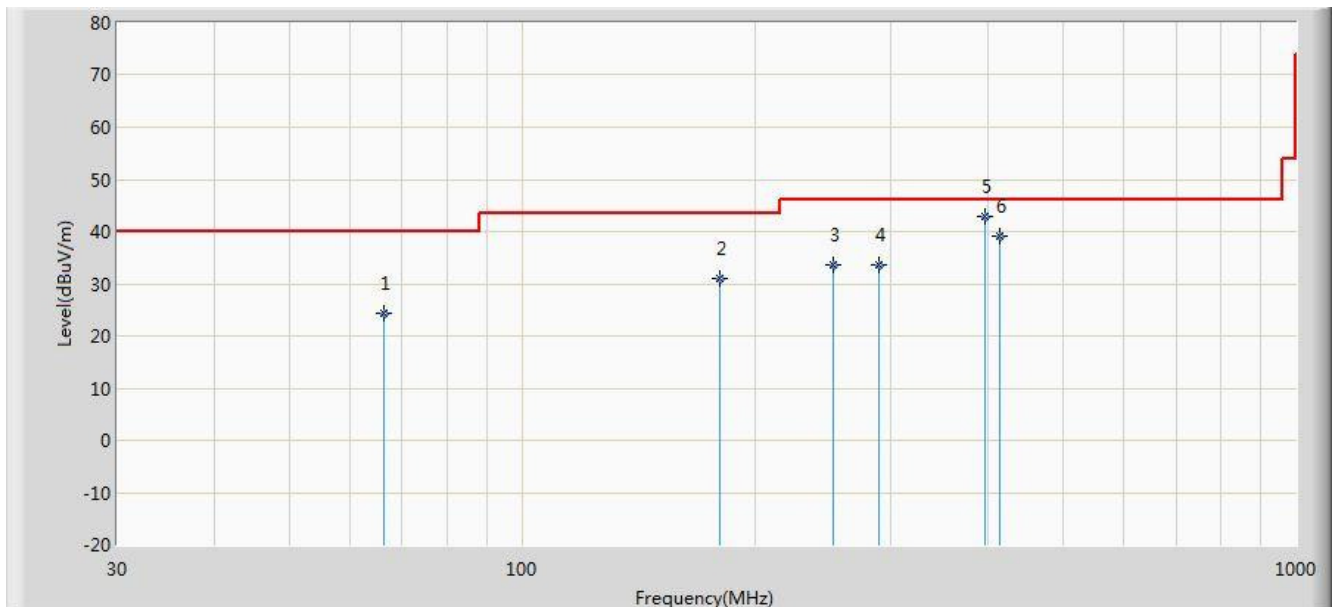

No	Flag	Mark	Frequency (MHz)	Measure Level (dBuV/m)	Reading Level (dBuV)	Over Limit (dB)	Limit (dBuV/m)	Factor (dB)	Ant Pos (cm)	Table Pos (deg)	Type
1			66.375	24.390	12.298	-15.610	40.000	12.092	100	247	QP
2			180.350	30.966	20.003	-12.534	43.500	10.962	100	214	QP
3			252.615	33.686	19.936	-12.314	46.000	13.750	100	56	QP
4			288.990	33.625	19.271	-12.375	46.000	14.353	100	162	QP
5		*	395.980	42.967	26.300	-3.033	46.000	16.667	100	152	QP
6			415.090	39.079	22.118	-6.921	46.000	16.961	100	102	QP

Note: Measure Level (dBuV/m) = Reading Level (dBuV) + Factor (dB)

Factor (dB) = Cable Loss (dB) + Antenna Factor (dB/m).

Site: AC2	Time: 2016/07/12 - 16:51
Limit: FCC_Part15.109_RE(3m)_Class B	Engineer: Line Chen
Probe: VULB9162_0.03-8GHz	Polarity: Vertical
EUT: E-reader	Power: AC 120V/60Hz
Test Mode 2	

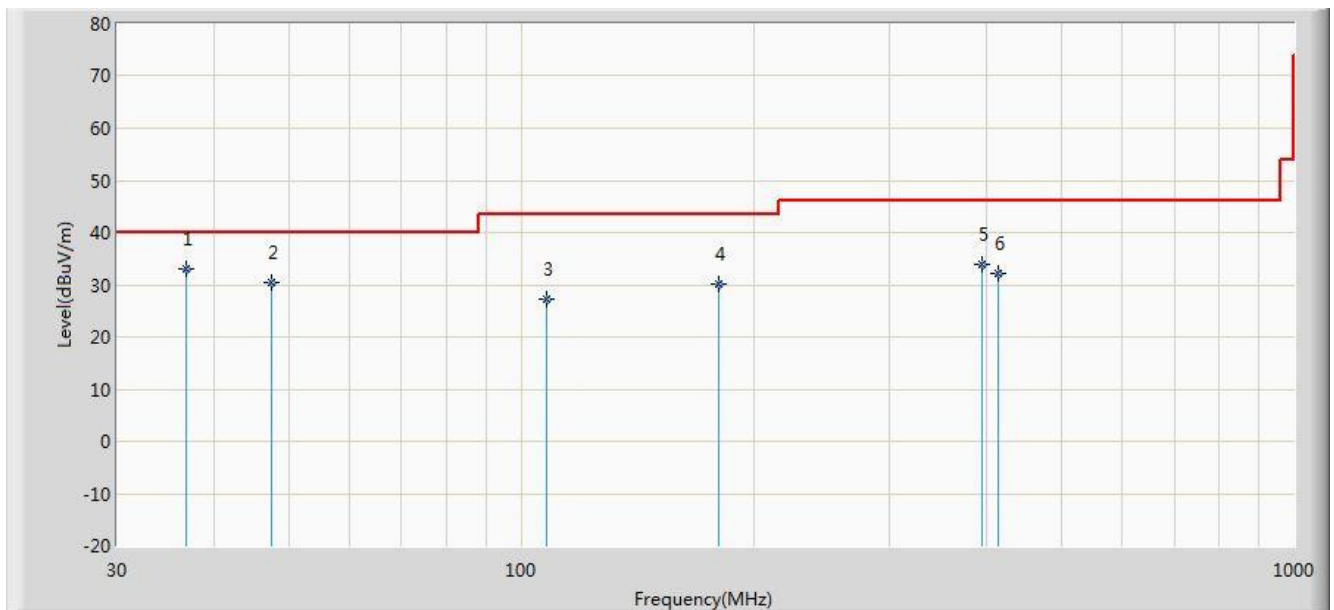

No	Flag	Mark	Frequency (MHz)	Measure Level (dBuV/m)	Reading Level (dBuV)	Over Limit (dB)	Limit (dBuV/m)	Factor (dB)	Ant Pos (cm)	Table Pos (deg)	Type
1		*	36.790	33.019	19.782	-6.981	40.000	13.237	100	125	QP
2			47.460	30.332	15.362	-9.668	40.000	14.969	100	76	QP
3			108.085	27.130	14.118	-16.370	43.500	13.013	100	287	QP
4			180.350	30.080	19.117	-13.420	43.500	10.962	100	219	QP
5			395.690	33.983	17.328	-12.017	46.000	16.654	100	155	QP
6			415.090	32.252	15.291	-13.748	46.000	16.961	100	98	QP

Note: Measure Level (dBuV/m) = Reading Level (dBuV) + Factor (dB)

Factor (dB) = Cable Loss (dB) + Antenna Factor (dB/m).

Site: AC2	Time: 2016/07/12 - 16:03
Limit: FCC_Part15.109_RE(3m)_Class B	Engineer: Line Chen
Probe: BBHA9120D_1-18GHz	Polarity: Horizontal
EUT: E-reader	Power: AC 120V/60Hz
Test Mode 1	

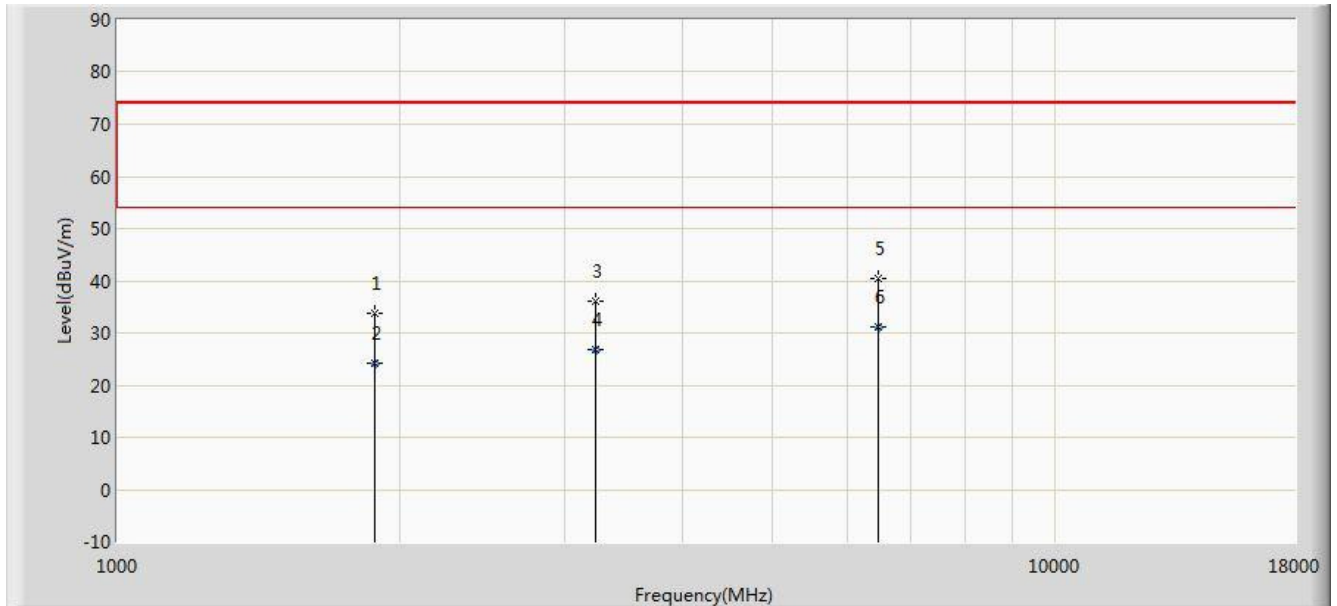

No	Flag	Mark	Frequency (MHz)	Measure Level (dBuV/m)	Reading Level (dBuV)	Over Limit (dB)	Limit (dBuV/m)	Factor (dB)	Ant Pos (cm)	Table Pos (deg)	Type
1			1884.000	33.685	38.942	-40.315	74.000	-5.256	100	261	PK
2			1884.500	24.268	29.521	-29.732	54.000	-5.253	100	270	AV
3			3235.500	36.141	38.612	-37.859	74.000	-2.471	100	118	PK
4			3236.000	26.896	29.371	-27.104	54.000	-2.475	100	123	AV
5			6474.000	40.473	33.368	-33.527	74.000	7.105	100	330	PK
6		*	6474.500	31.096	23.983	-22.904	54.000	7.113	100	323	AV

Note: Measure Level (dB μ V/m) = Reading Level (dB μ V) + Factor (dB)

Factor (dB) = Cable Loss (dB) + Antenna Factor (dB/m) – Pre_Amplifier Gain (dB).

Site: AC2	Time: 2016/07/12 - 16:03
Limit: FCC_Part15.109_RE(3m)_Class B	Engineer: Line Chen
Probe: BBHA9120D_1-18GHz	Polarity: Vertical
EUT: E-reader	Power: AC 120V/60Hz
Test Mode 1	

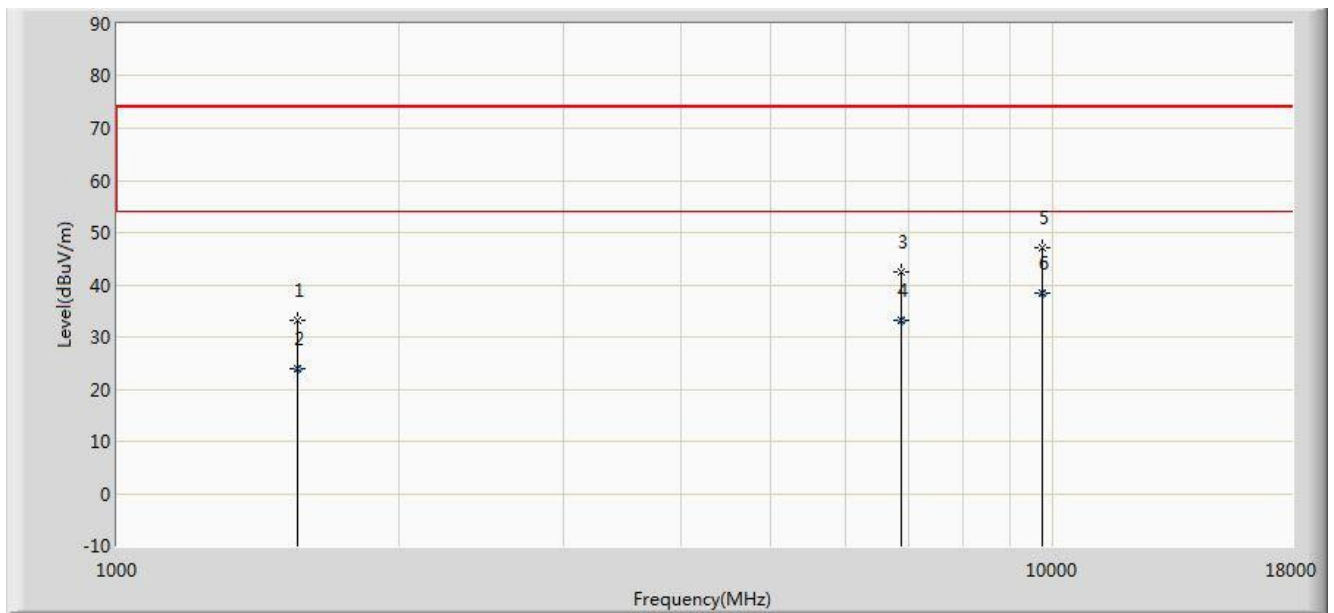

No	Flag	Mark	Frequency (MHz)	Measure Level (dBuV/m)	Reading Level (dBuV)	Over Limit (dB)	Limit (dBuV/m)	Factor (dB)	Ant Pos (cm)	Table Pos (deg)	Type
1			1561.000	33.317	39.382	-40.683	74.000	-6.065	100	220	PK
2			1561.500	23.942	30.001	-30.058	54.000	-6.060	100	208	AV
3			6882.000	42.492	34.185	-31.508	74.000	8.307	100	313	AV
4			6882.500	33.324	25.016	-20.676	54.000	8.308	100	324	PK
5			9755.000	47.097	34.124	-26.903	74.000	12.973	100	69	PK
6		*	9755.500	38.392	25.421	-15.608	54.000	12.970	100	76	AV

Note: Measure Level (dBuV/m) = Reading Level (dBuV) + Factor (dB)

Factor (dB) = Cable Loss (dB) + Antenna Factor (dB/m) – Pre_Amplifier Gain (dB).

Site: AC2	Time: 2016/07/12 - 16:08
Limit: FCC_Part15.109_RE(3m)_Class B	Engineer: Line Chen
Probe: BBHA9120D_1-18GHz	Polarity: Horizontal
EUT: E-reader	Power: AC 120V/60Hz
Test Mode 2	

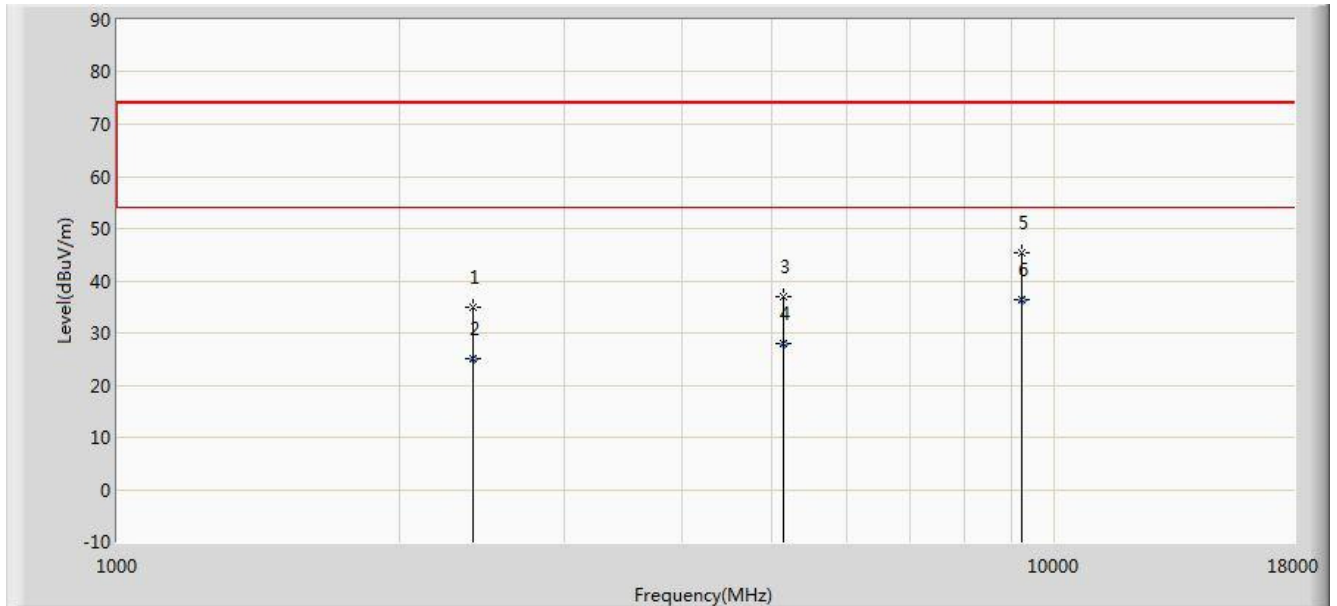

No	Flag	Mark	Frequency (MHz)	Measure Level (dBuV/m)	Reading Level (dBuV)	Over Limit (dB)	Limit (dBuV/m)	Factor (dB)	Ant Pos (cm)	Table Pos (deg)	Type
1			2394.000	34.904	37.568	-39.096	74.000	-2.664	100	78	PK
2			2394.500	25.007	27.672	-28.993	54.000	-2.665	100	85	AV
3			5131.000	37.011	33.857	-36.989	74.000	3.154	100	178	PK
4			5131.500	27.829	24.679	-26.171	54.000	3.150	100	183	AV
5			9228.000	45.246	32.111	-28.754	74.000	13.135	100	214	PK
6		*	9228.500	36.334	23.217	-17.666	54.000	13.117	100	220	AV

Note: Measure Level (dB μ V/m) = Reading Level (dB μ V) + Factor (dB)

Factor (dB) = Cable Loss (dB) + Antenna Factor (dB/m) – Pre_Amplifier Gain (dB).

Site: AC2	Time: 2016/07/12 - 16:08
Limit: FCC_Part15.109_RE(3m)_Class B	Engineer: Line Chen
Probe: BBHA9120D_1-18GHz	Polarity: Vertical
EUT: E-reader	Power: AC 120V/60Hz
Test Mode 2	

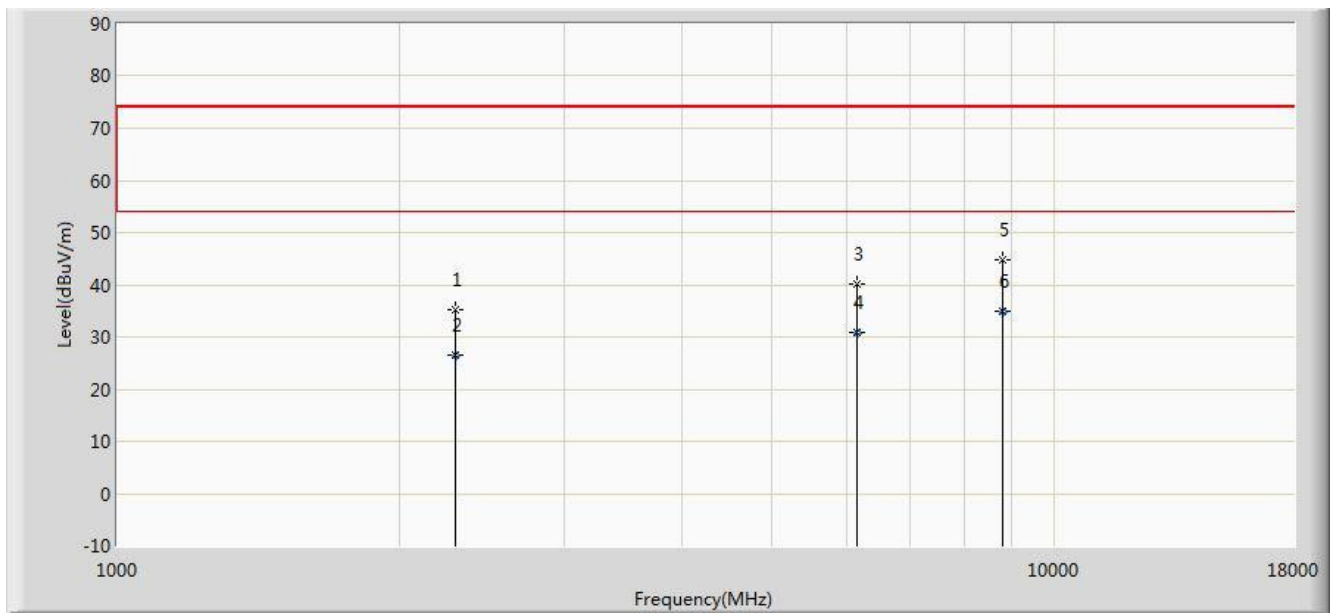

No	Flag	Mark	Frequency (MHz)	Measure Level (dBuV/m)	Reading Level (dBuV)	Over Limit (dB)	Limit (dBuV/m)	Factor (dB)	Ant Pos (cm)	Table Pos (deg)	Type
1			2292.000	35.143	37.270	-38.857	74.000	-2.127	100	117	PK
2			2292.500	26.405	28.532	-27.595	54.000	-2.127	100	121	AV
3			6151.000	40.191	34.411	-33.809	74.000	5.779	100	230	PK
4			6151.500	31.005	25.226	-22.995	54.000	5.779	100	224	AV
5			8803.000	44.648	32.921	-29.352	74.000	11.727	100	356	PK
6		*	8803.500	35.061	23.336	-18.939	54.000	11.725	100	349	AV

Note: Measure Level (dBuV/m) = Reading Level (dBuV) + Factor (dB)

Factor (dB) = Cable Loss (dB) + Antenna Factor (dB/m) – Pre_Amplifier Gain (dB).

————— The End —————